



**THE DATASHEET OF
DS3881E+T&R/C**



Single-Channel Automotive CCFL Controller

DS3881

General Description

The DS3881 is a single-channel cold-cathode fluorescent lamp (CCFL) controller for automotive applications that provides up to 300:1 dimming. It is ideal for driving CCFLs used to backlight liquid crystal displays (LCDs) in navigation and infotainment applications and for driving CCFLs used to backlight instrument clusters. The DS3881 is also appropriate for use in marine and aviation applications.

The DS3881 features EMI suppression functionality and provides a lamp current overdrive mode for rapid lamp heating in cold weather conditions. The DS3881 supports a single lamp configuration with fully independent lamp control and minimal external components. Multiple DS3881 controllers can be cascaded to support applications requiring more than one lamp. Control of the DS3881, after initial programming setup, can be completely achieved through I²C software communication. Many DS3881 functions are also pin-controllable if software control is not desired.

Applications

Automotive LCDs
Instrument Clusters
Marine and Aviation LCDs

Pin Configuration

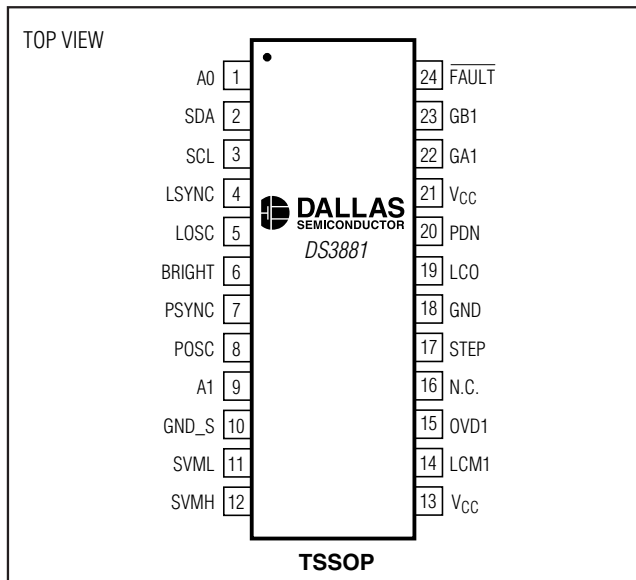

Typical Operating Circuit appears at end of data sheet.

Features

- ◆ Single-Channel CCFL Controller for Backlighting LCD Panels and Instrument Clusters in Automotive Navigation/Infotainment Applications
- ◆ Minimal External Components Required
- ◆ I²C Interface
- ◆ Per-Channel Lamp-Fault Monitoring for Lamp-Open, Lamp-Overcurrent, Failure to Strike, and Overvoltage Conditions
- ◆ Status Register Reports Fault Conditions
- ◆ Accurate ($\pm 5\%$) Independent On-Board Oscillators for Lamp Frequency (40kHz to 100kHz) and DPWM Burst-Dimming Frequency (22.5Hz to 440Hz)
- ◆ Lamp and DPWM Frequencies can be Synchronized with External Sources to Reduce Visual LCD Artifacts in Video Applications
- ◆ Spread-Spectrum Lamp Clock Reduces EMI
- ◆ Lamp Frequency can be Stepped Up or Down to Move EMI Spurs Out of Band
- ◆ Lamp Current Overdrive Mode with Automatic Turn-Off Quickly Warms Lamp in Cold Temperatures
- ◆ Analog or Digital Brightness Control
- ◆ 300:1 Dimming Range Possible Using the Digital Brightness Control Option
- ◆ Programmable Soft-Start Minimizes Audible Transformer Noise
- ◆ On-Board Nonvolatile (NV) Memory Allows Device Customization
- ◆ 8-Byte NV User Memory for Storage of Serial Numbers and Date Codes
- ◆ Low-Power Standby Mode
- ◆ 4.75V to 5.25V Single-Supply Operation
- ◆ Temperature Range: -40°C to $+105^{\circ}\text{C}$
- ◆ 24-Pin TSSOP Package

Ordering Information

PART	TEMP RANGE	PIN-PACKAGE
DS3881E+	-40°C to $+105^{\circ}\text{C}$	24 TSSOP (173 mils)
DS3881E+T&R	-40°C to $+105^{\circ}\text{C}$	24 TSSOP (173 mils)

+Denotes lead-free package.

Single-Channel Automotive CCFL Controller

ABSOLUTE MAXIMUM RATINGS

Voltage Range on V_{CC}, SDA, and
SCL Relative to Ground-0.5V to +6.0V
Voltage Range on Leads Other than V_{CC}, SDA, and
SCL-0.5V to (V_{CC} + 0.5V), not to exceed +6.0V

Operating Temperature Range-40°C to +105°C
EEPROM Programming Temperature Range0°C to +85°C
Storage Temperature Range-55°C to +125°C
Soldering Temperature.....See J-STD-020 Specification

Stresses beyond those listed under "Absolute Maximum Ratings" may cause permanent damage to the device. These are stress ratings only, and functional operation of the device at these or any other conditions beyond those indicated in the operational sections of the specifications is not implied. Exposure to absolute maximum rating conditions for extended periods may affect device reliability.

RECOMMENDED OPERATING CONDITIONS

(T_A = -40°C to +105°C)

PARAMETER	SYMBOL	CONDITIONS	MIN	TYP	MAX	UNITS
Supply Voltage	V _{CC}	(Note 1)	4.75		5.25	V
Input Logic 1	V _{IH}		2.0		V _{CC} + 0.3	V
Input Logic 0	V _{IL}		-0.3		1.0	V
SVML/H Voltage Range	V _{SVM}		-0.3		V _{CC} + 0.3	V
BRIGHT Voltage Range	V _{BRIGHT}		-0.3		V _{CC} + 0.3	V
LCM Voltage Range	V _{LCM}	(Note 2)	-0.3		V _{CC} + 0.3	V
OVD Voltage Range	V _{OVD}	(Note 2)	-0.3		V _{CC} + 0.3	V
Gate-Driver Output Charge Loading	Q _G				20	nC

ELECTRICAL CHARACTERISTICS

(V_{CC} = +4.75V to +5.25V, T_A = -40°C to +105°C.)

PARAMETER	SYMBOL	CONDITIONS	MIN	TYP	MAX	UNITS
Supply Current	I _{CC}	G _A , G _B loaded with 600pF		12		mA
Input Leakage (Digital Pins)	I _L		-1.0		+1.0	μA
Power-Down Current	I _{PDN}				1	mA
Output Leakage (SDA, $\overline{\text{FAULT}}$)	I _{LO}	High impedance	-1.0		+1.0	μA
Low-Level Output Voltage (LSYNC, PSYNC)	V _{OL}	I _{OL} = 4mA			0.4	V
Low-Level Output Voltage (SDA, $\overline{\text{FAULT}}$)	V _{OL1}	I _{OL1} = 3mA			0.4	V
	V _{OL2}	I _{OL2} = 6mA			0.6	
Low-Level Output Voltage (G _{A1} , G _{B1})	V _{OL3}	I _{OL3} = 4mA			0.4	V
High-Level Output Voltage (LSYNC, PSYNC)	V _{OH}	I _{OH} = -1mA	2.4			V

Single-Channel Automotive CCFL Controller

DS3881

ELECTRICAL CHARACTERISTICS (continued)

($V_{CC} = +4.75V$ to $+5.25V$, $T_A = -40^{\circ}C$ to $+105^{\circ}C$.)

PARAMETER	SYMBOL	CONDITIONS	MIN	TYP	MAX	UNITS
High-Level Output Voltage (GA, GB)	V_{OH1}	$I_{OH1} = -1mA$	$V_{CC} - 0.4$			V
UVLO Threshold: V_{CC} Rising	V_{UVLOR}				4.3	V
UVLO Threshold: V_{CC} Falling	V_{UVLOF}		3.7			V
UVLO Hysteresis	V_{UVLOH}			200		mV
SVML/H Threshold: Rising	V_{SVMR}		2.03	2.08	2.15	V
SVML/H Threshold: Falling	V_{SVMF}		1.95	2.02	2.07	V
LCM and OVD DC Bias Voltage	V_{DCB}			1.1		V
LCM and OVD Input Resistance	R_{DCB}			50		$k\Omega$
Lamp Off Threshold	V_{LOT}	(Note 3)	0.22	0.25	0.28	V
Lamp Over Current	V_{LOC}	(Note 3)	2.2	2.5	2.8	V
Lamp Regulation Threshold	V_{LRT}	(Notes 3, 4)	0.9	1.0	1.1	V
OVD Threshold	V_{OVDT}	(Note 3)	0.9	1.0	1.1	V
Lamp Frequency Source Frequency Range	$f_{LFS:OSC}$		40		100	kHz
Lamp Frequency Source Frequency Tolerance	$f_{LFS:TOL}$	LOSC resistor $\pm 2\%$ over temperature	-5		+5	%
Lamp Frequency Receiver Frequency Range	$f_{LFR:OSC}$		40		100	kHz
Lamp Frequency Receiver Duty Cycle	$f_{LFR:DUTY}$		40		60	%
DPWM Source (Resistor) Frequency Range	$f_{DSR:OSC}$		22.5		440.0	Hz
DPWM Source (Resistor) Frequency Tolerance	$f_{DSR:TOL}$	POSC resistor $\pm 2\%$ over temperature	-5		+5	%
DPWM Source (Ext. Clk) Frequency Range	$f_{DSE:OSC}$		22.5		440.0	Hz
DPWM Source (Ext. Clk) Duty Cycle	$f_{DFE:DUTY}$		40		60	%
DPWM Receiver Min Pulse Width	$t_{DR:MIN}$	(Note 5)	25			μs
BRIGHT Voltage: Minimum Brightness	V_{BMIN}				0.5	V
BRIGHT Voltage: Maximum Brightness	V_{BMAX}		2.0			V
Gate Driver Output Rise/Fall Time	t_R / t_F	$C_L = 600pF$			100	ns
GA1 and GB1 Duty Cycle		(Note 6)			44	%

Single-Channel Automotive CCFL Controller

I²C AC ELECTRICAL CHARACTERISTICS (See Figure 9)

(V_{CC} = +4.75V to +5.25V, T_A = -40°C to +105°C, timing referenced to V_{IL(MAX)} and V_{IH(MIN)}.)

PARAMETER	SYMBOL	CONDITIONS	MIN	TYP	MAX	UNITS
SCL Clock Frequency	f _{SCL}	(Note 7)	0		400	kHz
Bus Free Time Between Stop and Start Conditions	t _{BUF}		1.3			μs
Hold Time (Repeated) Start Condition	t _{HD:STA}	(Note 8)	0.6			μs
Low Period of SCL	t _{LOW}		1.3			μs
High Period of SCL	t _{HIGH}		0.6			μs
Data Hold Time	t _{HD:DAT}		0		0.9	μs
Data Setup Time	t _{SU:DAT}		100			ns
Start Setup Time	t _{SU:STA}		0.6			μs
SDA and SCL Rise Time	t _R	(Note 9)	20+ 0.1C _B		300	ns
SDA and SCL Fall Time	t _F	(Note 9)	20+ 0.1C _B		300	ns
Stop Setup Time	t _{SU:STO}		0.6			μs
SDA and SCL Capacitive Loading	C _B	(Note 9)			400	pF
EEPROM Write Time	t _w	(Note 10)		20	30	ms

NONVOLATILE MEMORY CHARACTERISTICS

(V_{CC} = +4.75V to +5.25V)

PARAMETER	SYMBOL	CONDITIONS	MIN	TYP	MAX	UNITS
EEPROM Write Cycles		+85°C (Note 11)	30,000			

Note 1: All voltages are referenced to ground unless otherwise noted. Currents into the IC are positive, out of the IC negative.

Note 2: During fault conditions, the AC-coupled feedback values are allowed to be below the absolute max rating of the LCM1 or OVD1 pin for up to 1 second.

Note 3: Voltage with respect to V_{DCB}.

Note 4: Lamp overdrive and analog dimming (based on reduction of lamp current) are disabled.

Note 5: This is the minimum pulse width guaranteed to generate an output burst, which will generate the DS3881's minimum burst duty cycle. This duty cycle may be greater than the duty cycle of the PSYNC input. Once the duty cycle of the PSYNC input is greater than the DS3881's minimum duty cycle, the output's duty cycle will track the PSYNC's duty cycle. Leaving PSYNC low (0% duty cycle) disables the GA1 and GB1 outputs in DPWM receiver mode.

Note 6: This is the maximum lamp frequency duty cycle that will be generated at GA1 or GB1 outputs with spread-spectrum modulation disabled.

Note 7: I²C interface timing shown is for fast-mode (400kHz) operation. This device is also backward compatible with I²C standard-mode timing.

Note 8: After this period, the first clock pulse can be generated.

Note 9: C_B—total capacitance allowed on one bus line in picofarads.

Note 10: EEPROM write time applies to all the EEPROM memory. EEPROM write begins after a stop condition occurs.

Note 11: Guaranteed by design.

Single-Channel Automotive CCFL Controller

Typical Operating Characteristics

DS3881

($V_{CC} = 5.0V$, $T_A = +25^\circ C$, unless otherwise noted.)

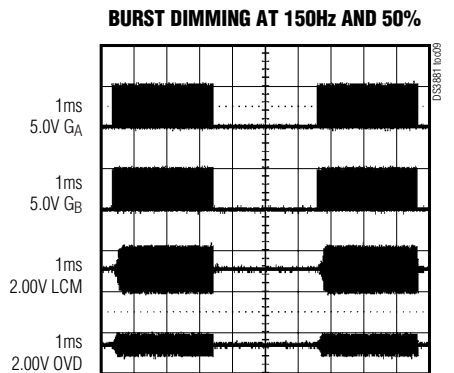
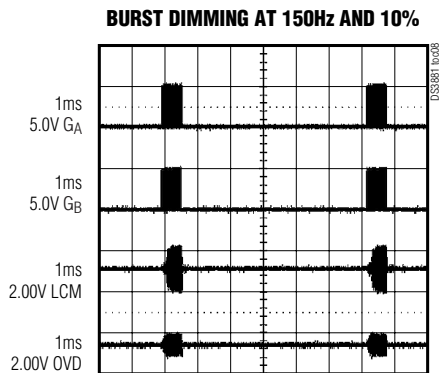
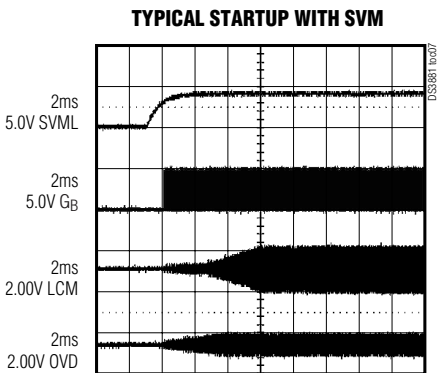
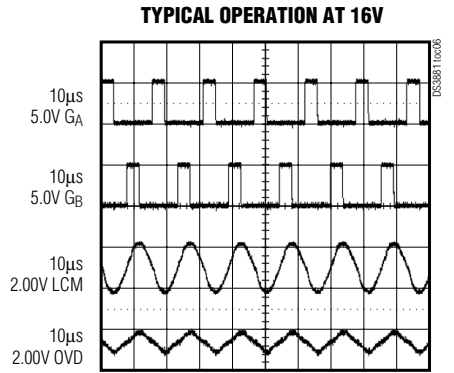
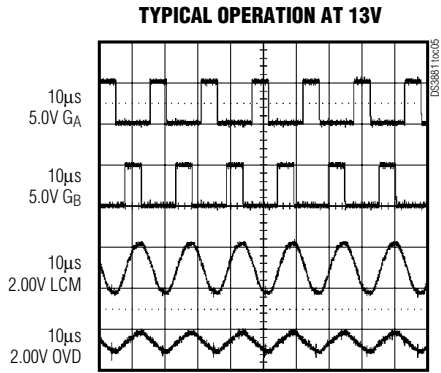
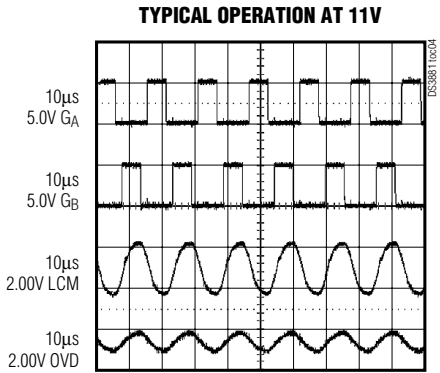
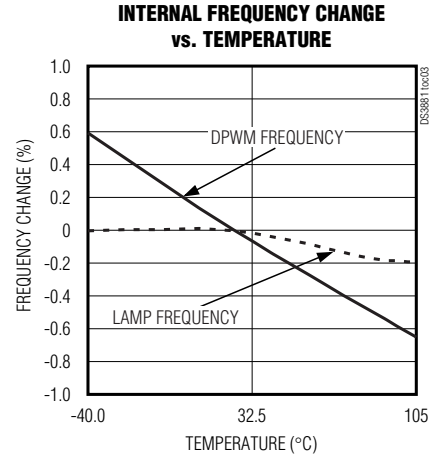
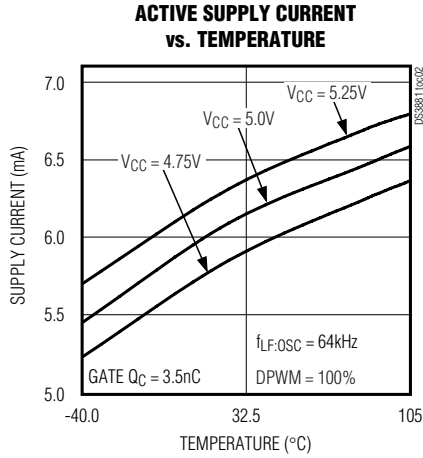

Single-Channel Automotive CCFL Controller

Typical Operating Characteristics (continued)

($V_{CC} = 5.0V$, $T_A = +25^{\circ}C$, unless otherwise noted.)

SOFT-START AT $V_{INV} = 16V$

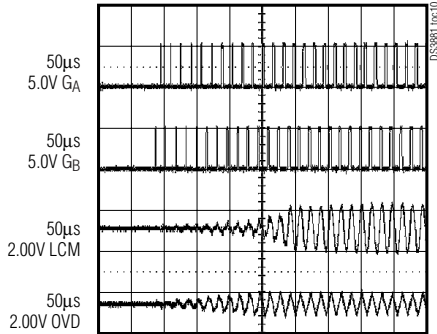

LAMP STRIKE—EXPANDED VIEW

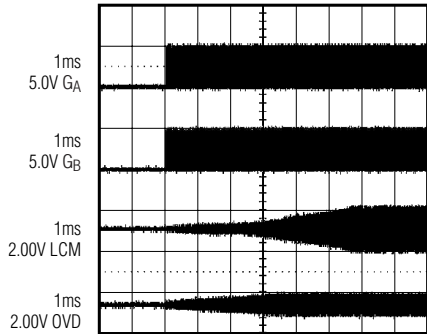

LAMP STRIKE WITH OPEN LAMP, AUTO RETRY DISABLED

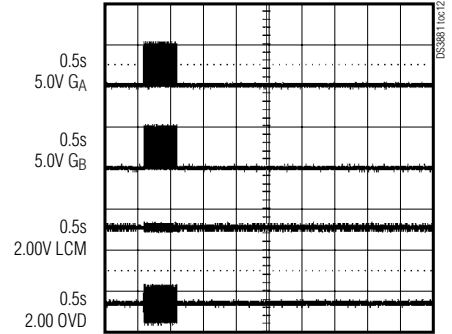

LAMP OUT (LAMP OPENED), AUTO-RETRY DISABLED

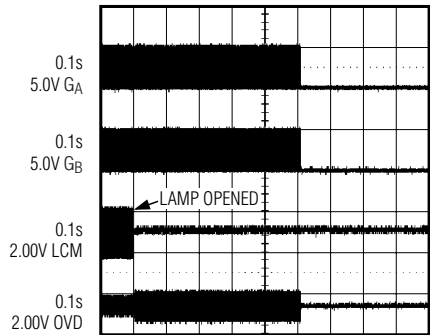

Single-Channel Automotive CCFL Controller

Pin Description

DS3881

PIN	NAME	FUNCTION
1, 9	A0, A1	Address Select Input. Determines I ² C slave address.
2	SDA	Serial Data Input / Output. I ² C bidirectional data pin, which requires a pullup resistor to realize high logic levels.
3	SCL	Serial Clock Input. I ² C clock input.
4	LSYNC	Lamp Frequency Input/Output. This pin is the input for an externally sourced lamp frequency when the DS3881 is configured as a lamp frequency receiver. If the DS3881 is configured as a lamp frequency source (i.e., the lamp frequency is generated internally), the frequency is output on this pin for use by other lamp frequency receiver DS3881s.
5	LOSC	Lamp Oscillator Resistor Adjust. A resistor to ground on this lead sets the frequency of the internal lamp oscillator.
6	BRIGHT	Analog Brightness Control Input. Used to control the DPWM dimming feature. Ground if unused.
7	PSYNC	DPWM Input/Output. This pin is the input for an externally generated DPWM signal when the DS3881 is configured as a DPWM receiver. If the DS3881 is configured as a DPWM source (i.e., the DPWM signal is generated internally), the DPWM signal is output on this pin for use by other DPWM receiver DS3881s.
8	POSC	DPWM Oscillator Resistor Adjust. A resistor to ground on this lead sets the frequency of the DPWM oscillator. This lead can optionally accept a 22.5Hz to 440Hz clock that will become the source timing of the internal DPWM signal.
10	GND_S	I ² C Interface Ground Connection. GND_S must be at the same potential as GND.
11	SVML	Low-Supply Voltage Monitor Input. Used to monitor the inverter voltage for undervoltage conditions.
12	SVMH	High-Supply Voltage Monitor Input. Used to monitor the inverter voltage for overvoltage conditions.
13, 21	VCC	Power Supply Connections. Both pins must be connected.
14	LCM1	Lamp Current Monitor Input. Lamp current is monitored by a resistor placed in series with the low voltage side of the lamp.
15	OVD1	Overvoltage Detection. Lamp voltage is monitored by a capacitor divider placed on the high voltage side of the transformer.
16	N.C.	No Connection. Do not connect any signal to this pin.
17	STEP	Lamp Frequency Step Input. This active-high digital input moves the lamp oscillator frequency up or down by either 1%, 2%, 3%, or 4% as configured in the EMIC register. This pin is logically ORed with the STEPE bit in the EMIC register.
18	GND	Ground Connection
19	LCO	Lamp Current Overdrive Enable Input. A high digital level at this input enables the lamp current overdrive circuit. The amount of overdrive current is configured by the LCOC register. When this input is low, the lamp current is set to its nominal level. This pin is logically ORed with the LCOE bit in the LCOC register.
20	PDN	Lamp On/Off Control Input. A low digital level at this input turns the lamp on. A high digital level clears the fault logic, turns the lamp off, and places the device into the power-down mode. This pin is logically ORed with the PDNE bit in the CR2 register.
22, 23	GA1, GB1	MOSFET A and B Gate Drive. Connect directly to logic-level mode n-channel MOSFET.
24	FAULT	Active-Low Fault Output. This open-drain pin requires external pullup resistor to realize high-logic levels.

Single-Channel Automotive CCFL Controller

Functional Diagrams

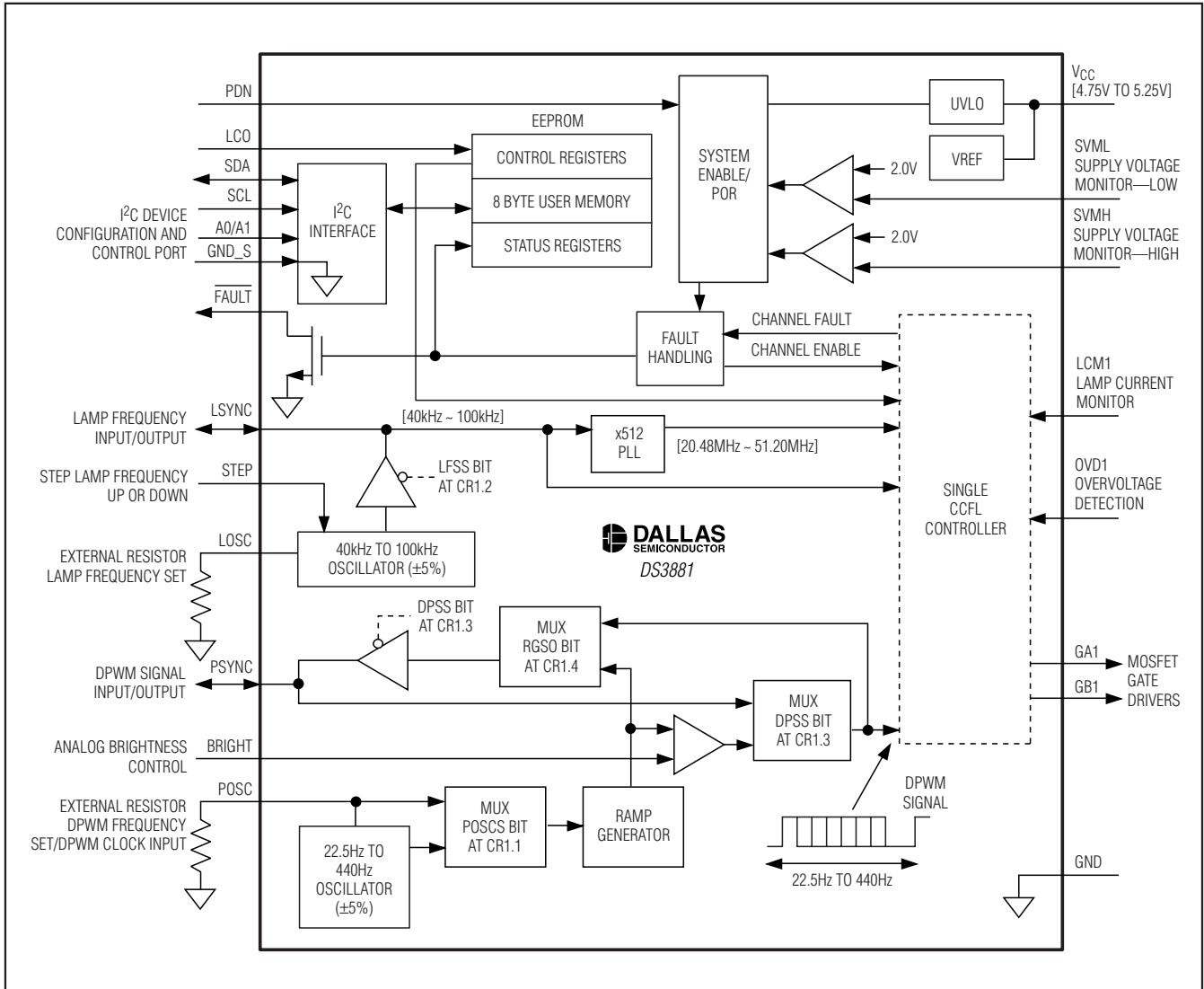

Figure 1. Functional Diagram

Single-Channel Automotive CCFL Controller

Functional Diagrams (continued)

DS3881

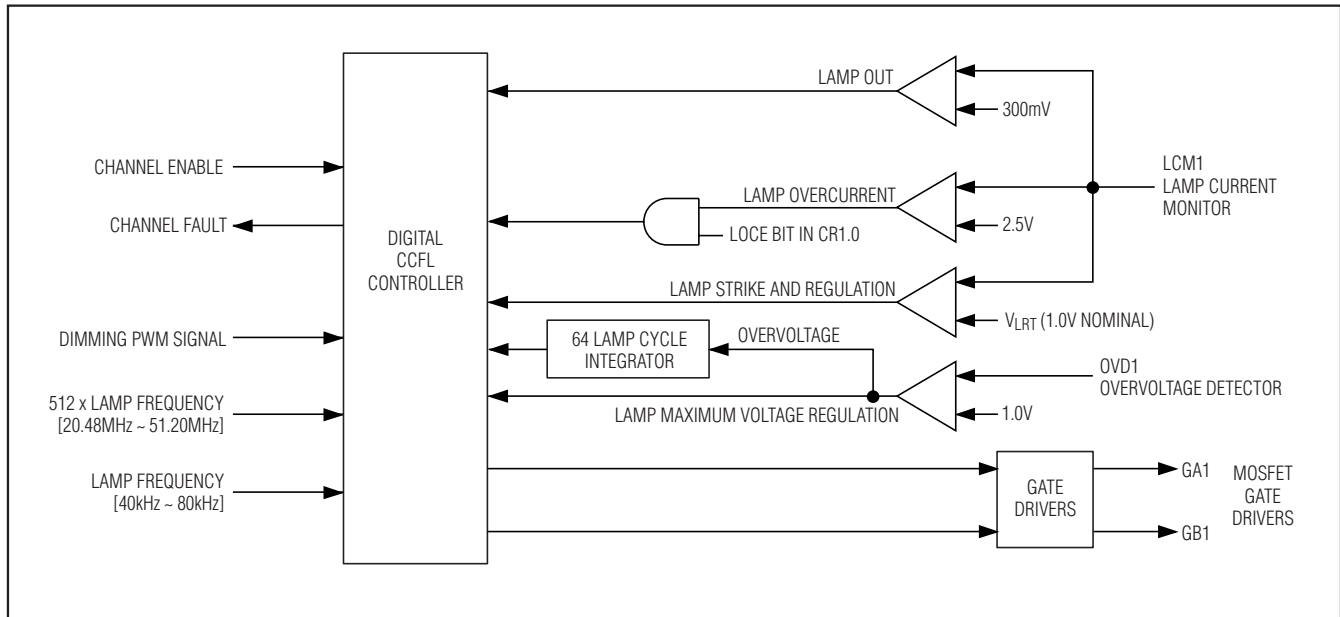

Figure 2. Per Channel Logic Diagram

Detailed Description

The DS3881 uses a push-pull drive scheme to convert a DC voltage (8V to 16V) to the high-voltage (300V_{RMS} to 1000V_{RMS}) AC waveform that is required to power the CCFL. The push-pull drive scheme uses a minimal number of external components, which reduces assembly cost and makes the printed circuit board design easy to implement. The push-pull drive scheme also provides an efficient DC-to-AC conversion and produces near-sinusoidal waveforms.

Each DS3881 drives two logic-level n-channel MOSFETs that are connected between the ends of a step-up transformer and ground (see the *Typical Operating Circuit*). The transformer has a center tap on the primary side that is connected to a DC voltage supply. The DS3881 alternately turns on the two MOSFETs to create the high-voltage AC waveform on the secondary side. By varying the duration of the MOSFET turn-on times, the CCFL current is able to be accurately controlled.

A resistor in series with the CCFL's ground connection enables current monitoring. The voltage across this resistor is fed to the lamp current monitor (LCM) input and compared to an internal reference voltage to deter-

mine the duty cycle for the MOSFET gates. The CCFL receives current monitoring and control, which maximizes the lamp's brightness and lifetime.

Block diagrams of the DS3881 are shown in Figures 1 and 2. More operating details of the DS3881 are discussed on the following pages of this data sheet.

Memory Registers and I²C-Compatible Serial Interface

The DS3881 uses an I²C-compatible serial interface for communication with the on-board EEPROM and SRAM configuration/status registers as well as user memory. The configuration registers, which are a mixture of shadowed EEPROM and SRAM, allow the user to customize many DS3881 parameters such as the soft-start ramp rate, the lamp and dimming frequency sources, brightness of the lamps, fault-monitoring options, channel enabling/disabling, EMI control, and lamp current overdrive control. The eight bytes of NV user memory can be used to store manufacturing data such as date codes, serial numbers, or product identification numbers. The device is shipped from the factory with the configuration registers programmed to a set of default configuration parameters. To inquire about custom programming, contact the factory.

Single-Channel Automotive CCFL Controller

Shadowed EEPROM

The DS3881 incorporates SRAM-shadowed EEPROM memory locations for all memory that needs to be retained during power cycling. At power-up, SEEB (bit 7 of the BLC register) is low, which causes the shadowed locations to act as ordinary EEPROM. Setting SEEB high disables the EEPROM write function and causes the shadowed locations to function as ordinary SRAM cells. This allows an infinite number of write cycles without causing EEPROM damage and also eliminates the EEPROM write time, t_{W} from the write cycle. Because memory changes made when SEEB is set high are not written to EEPROM, these changes are not retained through power cycles, and the power-up EEPROM values are the last values written with SEEB low.

Lamp Dimming Control

The DS3881 provides two independent methods of lamp dimming that can be combined to achieve a dimming ratio of 300:1 or greater. The first method is “burst” dimming, which uses a digital pulse-width-modulated (DPWM) signal (22.5Hz to 440Hz) to control the lamp brightness. The second is “analog” dimming, which is accomplished by adjusting the lamp current. Burst dimming provides 128 linearly spaced brightness steps. Analog dimming provides smaller substeps that allow incremental brightness changes between burst dimming steps. This ability is especially useful for low-brightness dimming changes, where using burst dimming alone would cause visible brightness step changes. Analog dimming also allows the brightness to be reduced below the minimum burst dimming level, which provides for the maximum dimming range.

Burst dimming can be controlled using a user-supplied analog voltage on the BRIGHT pin or through the I²C interface. Analog dimming can only be controlled through the I²C interface. Therefore, for applications that require the complete dimming range and resolution capability of the DS3881, I²C dimming control must be used.

Burst Dimming

Burst dimming increases/decreases the brightness by adjusting (i.e., modulating) the duty cycle of the DPWM signal. During the high period of the DPWM cycle, the lamps are driven at the selected lamp frequency (40kHz to 100kHz) as shown in Figure 6. This part of the cycle is called the “burst” period because of the lamp frequency burst that occurs during this time. During the low period of the DPWM cycle, the controller disables the MOSFET gate drivers so the lamps are not driven. This causes the current to stop flowing in the lamps, but the time is short enough to keep the lamps from de-ionizing.

The DS3881 can generate its own DPWM signal internally (set DPSS = 0 in CR1), which can then be sourced to other DS3881s if required, or the DPWM signal can be supplied from an external source (set DPSS = 1 in CR1). To generate the DPWM signal internally, the DS3881 requires a clock (referred to as the dimming clock) to set the DPWM frequency. The user can supply the dimming clock by setting POSCS = 1 in CR1 and applying an external 22.5Hz to 440Hz signal at the POSC pin, or the dimming clock can be generated by the DS3881’s internal oscillator (set POSCS = 0 in CR1), in which case the frequency is set by an external resistor at the POSC pin. These two dimming clock options are shown in Figure 3. Regardless of whether the dimming clock is generated internally or sourced externally, the POSCR0 and POSCR1 bits in CR2 must be set to match the desired dimming clock frequency.

The internally generated DPWM signal can be provided at the PSYNC I/O pin (set RGSO = 0 in CR1) for sourcing to other DS3881s, if any, in the circuit. This allows all DS3881s in the system to be synchronized to the same DPWM signal. A DS3881 that is generating the DPWM signal for other DS3881s in the system is referred to as the DPWM source. When bringing in an externally generated DPWM signal, either from another DS3881 acting as a DPWM source or from some other user-provided source, it is input into the PSYNC I/O pin of the DS3881, and the receiving DS3881 is referred to a DPWM receiver. In this mode, the BRIGHT and POSC inputs are disabled and should be grounded (see Figure 5).

When the DPWM signal is generated internally, its duty cycle (and, thus, the lamp brightness) is controlled either by a user-supplied analog voltage at the BRIGHT input or through the I²C interface by varying the 7-bit PWM code in the BPWM register. When using the BRIGHT pin to control burst dimming, a voltage of less than 0.5V causes the DS3881 to operate with the minimum burst duty cycle, providing the lowest brightness setting, while any voltage greater than 2.0V causes a 100% burst duty cycle (i.e., lamps always being driven), which provides the maximum brightness. For voltages between 0.5V and 2V, the duty cycle varies linearly between the minimum and 100%. Writing a non-zero PWM code to the BPWM register disables the BRIGHT pin and enables I²C burst dimming control. Setting the 7-bit PWM code to 0000001b causes the DS3881 to operate with the minimum burst duty cycle, while a setting of 1111111b causes a 100% burst duty cycle. For settings between these two codes, the duty cycle varies linearly between the minimum and 100%.

Single-Channel Automotive CCFL Controller

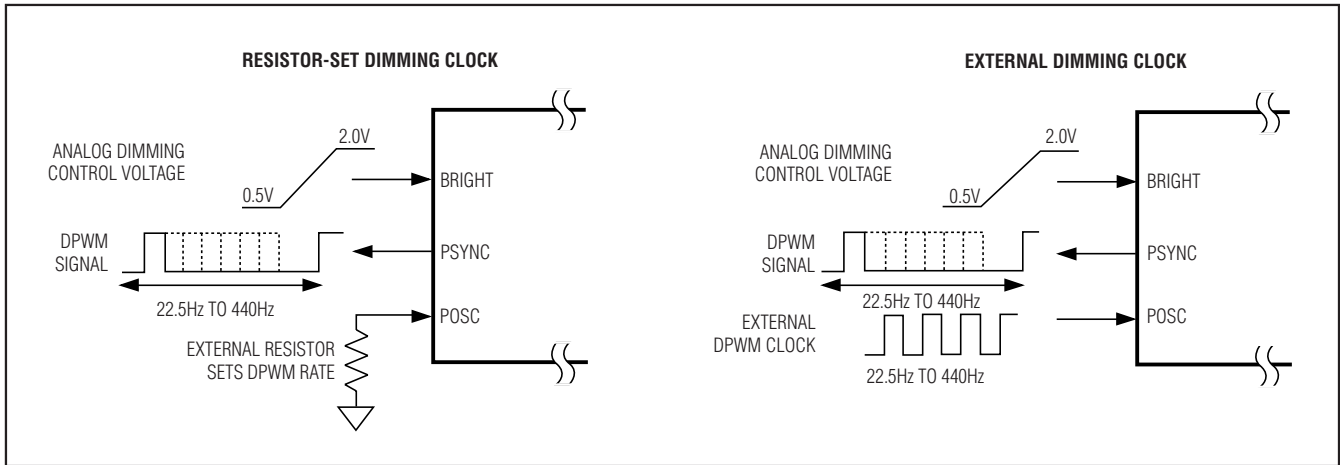

Figure 3. DPWM Source Configuration Options

Analog Dimming

Analog dimming changes the brightness by increasing or decreasing the lamp current. The DS3881 accomplishes this by making small shifts to the lamp regulation voltage, V_{LRT} (see Figure 2). Analog dimming is only possible by software communication with the lower five bits (LC4-LC0) in the BLC register. This function is not pin controllable. The default power-on state of the LC bits is 00000b, which corresponds to 100% of the nominal current level. Therefore on power-up, analog dimming does not interfere with burst dimming functionality if it is not desired. Setting the LC bits to 11111b reduces the lamp current to 35% of its nominal level. For LC values between 11111b and 00000b, the lamp current varies linearly between 35% and 100% of nominal.

Lamp Frequency Configuration

The DS3881 can generate its own lamp frequency clock internally (set LFSS = 0 in CR1), which can then be sourced to other DS3881s if required, or the lamp clock can be supplied from an external source (set LFSS = 1 in CR1). When the lamp clock is internally generated, the frequency (40kHz to 100kHz) is set by an external resistor at the LOSC. In this case, the DS3881 can act as a lamp frequency source because the lamp clock is output at the LSYNC I/O pin for synchronizing any other DS3881s configured as lamp frequency receivers. While DS3881 is sourcing lamp frequency to other DS3881's and spread-spectrum modulation or frequency step features are enabled, the LSYNC output is not affected by either EMI suppression features. The DS3881 acts as a lamp frequency receiver when the lamp clock is supplied externally. In this case, a 40kHz to 100kHz clock must be supplied at the

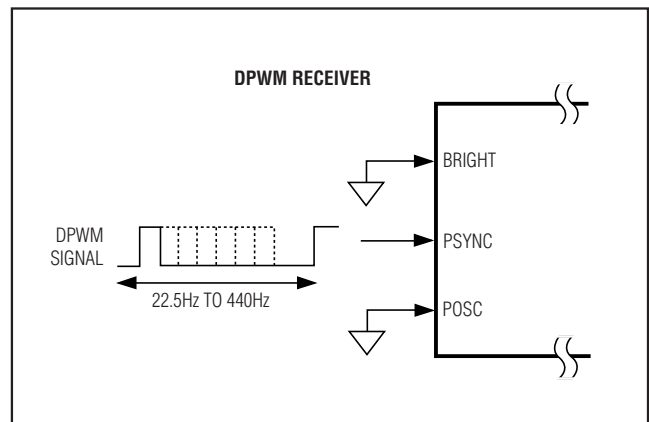

Figure 4. DPWM Receiver Configuration

LSYNC I/O. The external clock can originate from the LSYNC I/O of a DS3881 configured as a lamp frequency source or from some other source.

Configuring Systems with Multiple DS3881s

The source and receiver options for the lamp frequency clock and DPWM signal allow multiple DS3881s to be synchronized in systems requiring more than 1 lamp. The lamp and dimming clocks can either be generated on board the DS3881 using external resistors to set the frequency, or they can be sourced by the host system to synchronize the DS3881 to other system resources. Figure 5 shows various multiple DS3881 configurations that allow both lamp and/or DPWM synchronization for all DS3881s in the system.

Single-Channel Automotive CCFL Controller

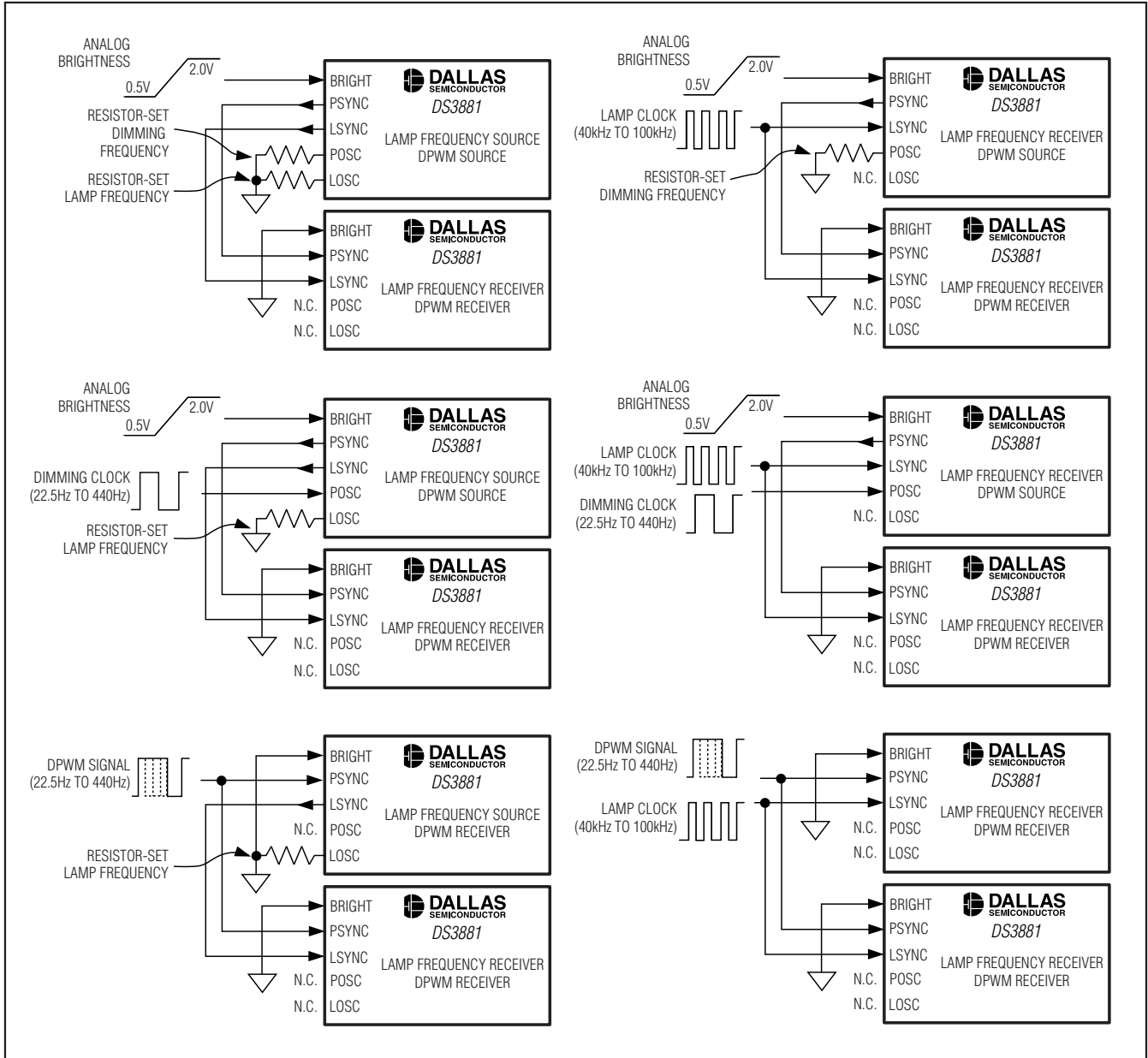

Figure 5. Frequency Configuration Options for Designs Using Multiple DS3881s

Single-Channel Automotive CCFL Controller

DS3881

DPWM Soft-Start

At the beginning of each lamp burst, the DS3881 provides a soft-start that slowly increases the MOSFET gate-driver duty cycle (see Figure 6). This minimizes the possibility of audible transformer noise that could result from current surges in the transformer primary. The soft-start length is fixed at 16 lamp cycles, but the soft-start ramp profile is programmable through the four soft-start profile registers (SSP1/2/3/4) and can be adjusted to match the application. There are seven

different driver duty cycles to select from to customize the soft-start ramp (see Tables 4a and 4b). The available duty cycles range from 0% to 19% in ~3% increments. In addition, the MOSFET duty cycle from the last lamp cycle of the previous burst can be used as part of the soft-start ramp by using the most recent value duty cycle code. Each programmed MOSFET gate duty cycle repeats twice to make up the 16 soft-start lamp cycles.

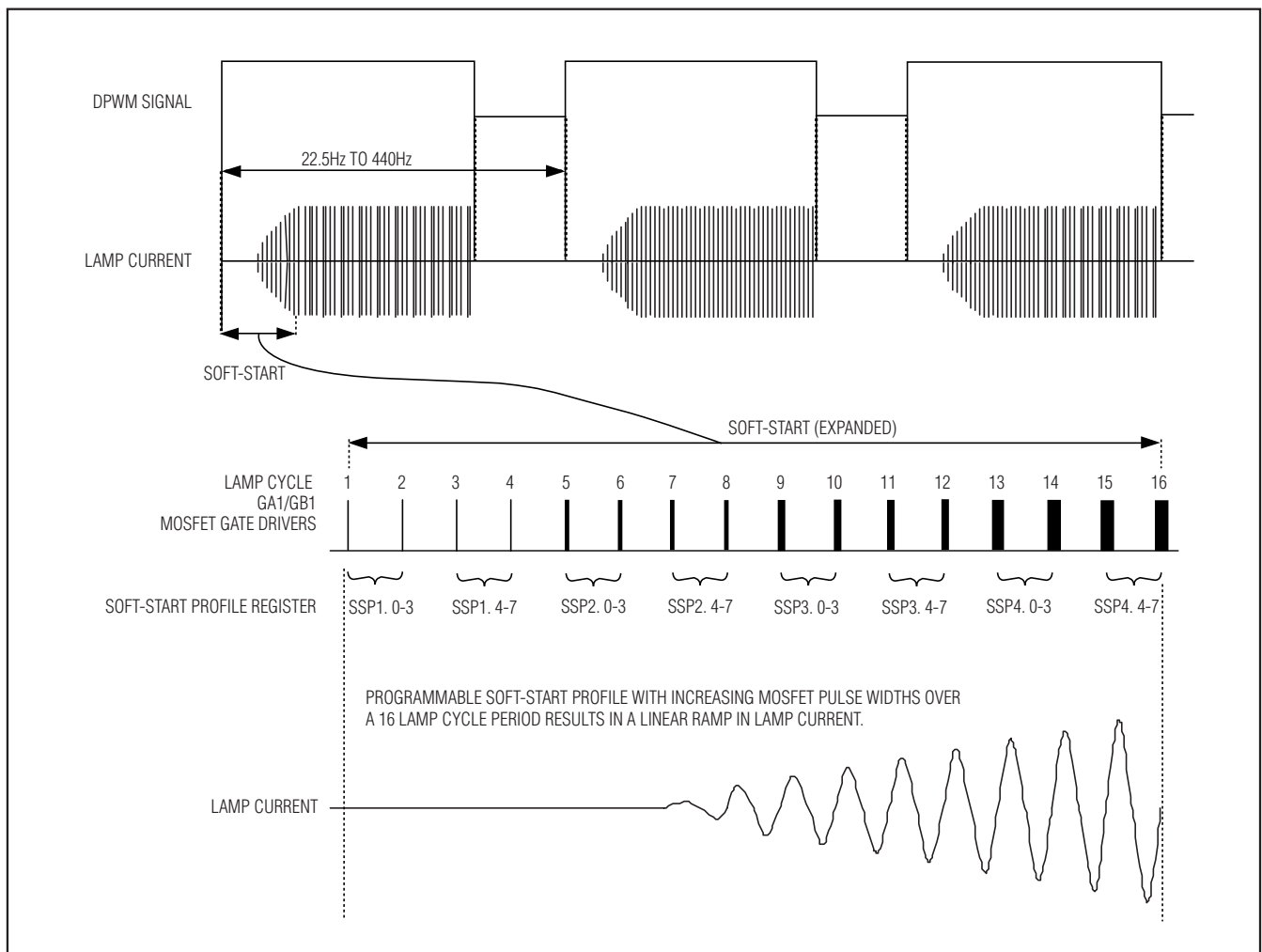

Figure 6. Digital PWM Dimming and Soft-Start

Single-Channel Automotive CCFL Controller

Setting the Lamp and Dimming Clock (DPWM) Frequencies Using External Resistors

Both the lamp and dimming clock frequencies can be set using external resistors. The resistance required for either frequency can be determined using the following formula:

$$R_{OSC} = \frac{K}{f_{OSC}}$$

where $K = 1600k\Omega \cdot kHz$ for lamp frequency calculations. When calculating the resistor value for the dimming clock frequency, K will be one of four values as determined by the desired frequency and the POSCR0 and POSCR1 bit settings as shown in the Control Register 2 (CR2) Table 6 in the *Detailed Register Descriptions* section.

Example: Selecting the resistor values to configure a DS3881 to have a 50kHz lamp frequency and a 160Hz dimming clock frequency: For this configuration, POSCR0 and POSCR1 must be programmed to 1 and 0, respectively, to select 90Hz to 220Hz as the dimming clock frequency range. This sets K for the dimming clock resistor (R_{POSC}) calculation to $4k\Omega \cdot kHz$. For the lamp frequency resistor (R_{LOSC}) calculation, $K = 1600k\Omega \cdot kHz$, which sets the lamp frequency K value regardless of the frequency. The formula above can now be used to calculate the resistor values for R_{LOSC} and R_{POSC} as follows:

$$R_{LOSC} = \frac{1600k\Omega \cdot kHz}{50kHz} = 32.0k\Omega$$

$$R_{POSC} = \frac{4k\Omega \cdot kHz}{0.160kHz} = 25.0k\Omega$$

Supply Monitoring

The DS3881 has supply voltage monitors (SVMs) for both the inverter's transformer DC supply (V_{INV}) and its own V_{CC} supply to ensure that both voltage levels are adequate for proper operation. The transformer supply is monitored for overvoltage conditions at the SVMH pin and undervoltage conditions at the SVML pin. External resistor-dividers at each SVM input feed into two comparators (see Figure 7), both having 2V thresholds. Using the equation below to determine the resistor values, the SVMH and SVML trip points (V_{TRIP}) can be customized to shut off the inverter when the transformer's supply voltage rises above or drops below specified values. Operating with the transformer's supply at too low of a level can prevent the inverter from

reaching the strike voltage and could potentially cause numerous other problems. Operating with the transformer voltage at too high of a level can be damaging to the inverter components. Proper use of the SVMs can prevent these problems. If desired, the high and/or low SVMs can be disabled by connecting the SVMH pin to GND and the SVML pin to V_{CC} .

$$V_{TRIP} = 2.0 \left(\frac{R_1 + R_2}{R_1} \right)$$

The V_{CC} monitor is used as a 5V supply undervoltage lockout (UVLO) that prevents operation when the DS3881 does not have adequate voltage for its analog circuitry to operate or to drive the external MOSFETs. The V_{CC} monitor features hysteresis to prevent V_{CC} noise from causing spurious operation when V_{CC} is near the trip point. This monitor cannot be disabled by any means.

Fault Monitoring

The DS3881 provides extensive fault monitoring. It can detect open-lamp, lamp overcurrent, failure to strike, and overvoltage conditions. The DS3881 can be configured to disable the output if the channel enters a fault state. Once a fault state has been entered, the **FAULT** output is asserted and the channel remains disabled until it is reset by a user or host control event. See *Step 4, Fault Handling* for more detail. The DS3881 can also be configured to automatically attempt to clear a detected fault (except lamp overcurrent) by re-striking the lamp. Configuration bits for the fault monitoring options are located in CR1 and CR2. The DS3881 also has real-time status indicator bits located in the SR1 and SR2 register (SRAM) that assert whenever a corresponding fault occurs.

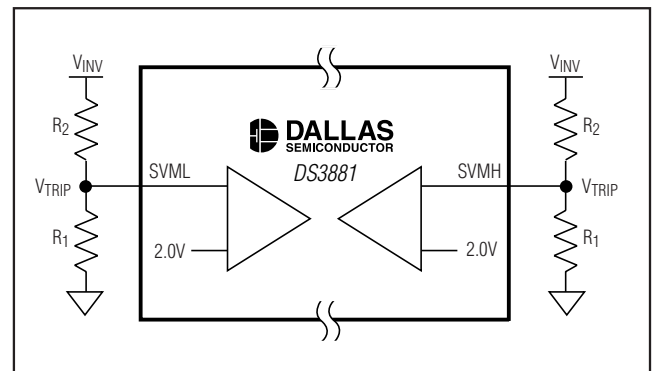

Figure 7. Setting the SVM Threshold Voltage

Single-Channel Automotive CCFL Controller

Figure 8 shows a flowchart of how the DS3881 controls and monitors each lamp. The steps are as follows:

- 1) **Supply Check**—The lamps do not turn on unless the DS3881 supply voltage is above 4.3V and the voltage at the supply voltage monitors, SVML and SVMH, are respectively above 2.0V and below 2.0V.
- 2) **Strike Lamp**—When both the DS3881 and the DC inverter supplies are at acceptable levels, the DS3881 attempts to strike the lamp. The DS3881 slowly ramps up the MOSFET gate duty cycle until the lamp strikes. The controller detects that the lamp has struck by detecting current flow in the lamp, detected by the LCM1 pin. If during the strike ramp, the maximum allowable voltage is reached on the OVD1 pin, the controller stops increasing the MOSFET gate duty cycle to keep from overstressing the system. The DS3881 goes into a fault handling state (step 4) if the lamp has not struck after the timeout period as defined by the LST0 and LST1 control bits in the SSP1 register. If an overvoltage event is detected during the strike attempt, the DS3881 disables the MOSFET gate drivers and go into the fault handling state.
- 3) **Run Lamp**—Once the lamp is struck, the DS3881 adjusts the MOSFET gate duty cycle to optimize the lamp current. The gate duty cycle is always constrained to keep the system from exceeding the maximum allowable lamp voltage. The lamp current sampling rate is user-selectable using the LSR0 and LSR1 bits in CR2. If lamp current ever drops below the lamp out reference point for the period as defined by the LST0 and LST1 control bits in the SSP1 register, then the lamp is considered extinguished. In this case, the MOSFET gate drivers are disabled and the device moves to the fault handling stage.
- 4) **Fault Handling**—During fault handling, the DS3881 performs an optional (user-selectable) automatic retry to attempt to clear all faults except a lamp overcurrent. The automatic retry makes 14 additional attempts to rectify the fault before declaring the channel in a fault state and permanently disabling the channel. Between each of the 14 attempts, the controller waits 1024 lamp cycles. In the case of a lamp overcurrent, the DS3881 instantaneously declares the channel to be in a fault state and permanently disables the channel. Once a fault state is entered, the channel remains in that state until one of the following occurs:
 - V_{CC} drops below the UVLO threshold.
 - The SVML or SVMH thresholds are crossed.
 - The PDN pin goes high.
 - The PDNE software bit is written to a logic 1.
 - The channel is disabled by the CH1D control bit.

Single-Channel Automotive CCFL Controller

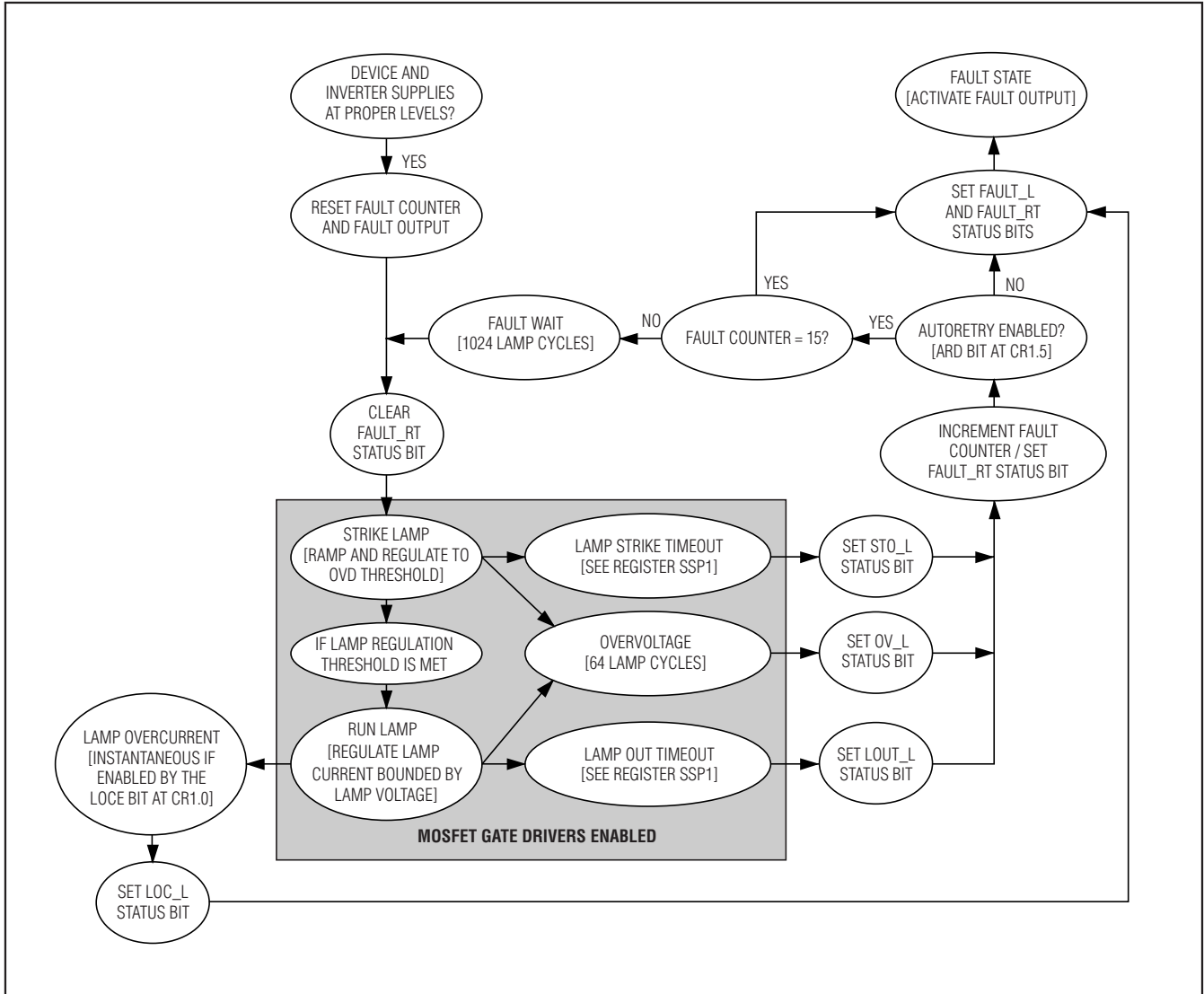

Figure 8. Fault-Handling Flowchart

Single-Channel Automotive CCFL Controller

DS3881

EMI Suppression Functionality

The DS3881 contains two electromagnetic interference suppression features: spread-spectrum modulation and lamp oscillator frequency stepping. The first is the ability to spread the spectrum of the lamp frequency. By setting either SS0 and/or SS1 in EMIC register, the controller can be configured to dither the lamp frequency by $\pm 1.5\%$, $\pm 3\%$, or $\pm 6\%$. By setting a non-zero value in SS0/1, spread-spectrum modulation is enabled and oscillator frequency stepping is disabled. In spread-spectrum modulation mode the dither modulation rate is also selectable by setting FS0/1/2, and has either a triangular (SSM = 0) or a pseudorandom profile (SSM = 1). Users have the flexibility to choosing the best modulation rate (through FS0/1/2) for the application.

The second EMI suppression scheme is the ability to move the lamp frequency up or down by 1%, 2%, 3%, or 4%. In this scheme, the actual radiated EMI is not reduced but it is moved out of a sensitive frequency region. STEPE bit and/or STEP pin is used to enable lamp frequency stepping (SS0/1 must be 0). Once enabled, the FS0/1/2 value controls the lamp oscillator frequency shift. For example, if the lamp frequency creates EMI disturbing an audio radio station, it can be moved up or down slightly to slide the spurious interferer out of band.

Lamp Current Overdrive Functionality

Another feature the DS3881 offers is the ability to overdrive the lamps to allow them to heat up quickly in cold environments. After setting the LCO0/1/2 bits in the LCO register and enabling the LCOE bit or LCO pin, the DS3881 overdrives the nominal current settings in 12.5% steps from 112.5% up to 200%. The DS3881 accomplishes this by automatically shifting the lamp regulation threshold, V_{LRT} , upward to allow more current to flow in the lamps (Figure 2). This multilevel adjustment makes it possible to slowly decrease the current overdrive (through I^2C) after the lamps have warmed up, so the end user does not see any change in brightness when the overdrive is no longer needed. The DS3881 also features an optional timer capable of automatically turning off the current overdrive. This timer is adjustable from approximately 1.5 minutes to 21 minutes (if a 50kHz lamp frequency is used).

Detailed Register Descriptions

The DS3881's register map is shown in Table 1. Detailed register and bit descriptions follow in the subsequent tables.

Table 1. Register Map

BYTE ADDRESS	BYTE NAME	FACTORY DEFAULT	BIT 7	BIT 6	BIT 5	BIT 4	BIT 3	BIT 2	BIT 1	BIT 0
E0h	SR1	00h	SVMH_RT	SVML_RT	LOC_L1	LOUT_L1	OV_L1	STO_L1	FAULT_L1	FAULT_RT1
E1h	RSVD	00h	RSVD	RSVD	RSVD	RSVD	RSVD	RSVD	RSVD	RSVD
E2h	BPWM	00h	RSVD	PWM6	PWM5	PWM4	PWM3	PWM2	PWM1	PWM0
E3h	BLC	1Fh	SEEB	RSVD	CH1D	LC4	LC3	LC2	LC1	LC0
F0h	SSP1	21h	LST1	MDC code for soft-start lamp cycles 3, 4			LST0	MDC code for soft-start lamp cycles 1, 2		
F1h	SSP2	43h	MDC code for soft-start lamp cycles 7, 8				MDC code for soft-start lamp cycles 5, 6			
F2h	SSP3	65h	MDC code for soft-start lamp cycles 11, 12				MDC code for soft-start lamp cycles 9, 10			
F3h	SSP4	77h	MDC code for soft-start lamp cycles 15, 16				MDC code for soft-start lamp cycles 13, 14			
F4h	CR1	00h	DPD	RSVD	ARD	RGSO	DPSS	LFSS	POSCS	LOCE
F5h	CR2	08h	PDNE	RSVD	RSVD	LSR1	LSR0	POSCR1	POSCR0	UMWP
F6h	EMIC	00h	FS2	FS1	FS0	STEPE	RSVD	SSM	SS1	SS0
F7h	LCOE	00h	TO3	TO2	TO1	TO0	LCOE	LCO2	LCO1	LCO0
F8h–FFh	USER	00h	EE	EE	EE	EE	EE	EE	EE	EE

Note 1: E0h–E3h are SRAM locations, and F0h–FFh are SRAM-shadowed EEPROM.

Note 2: Altering the DS3881 configuration during active CCFL operation can cause serious adverse effects.

Single-Channel Automotive CCFL Controller

Table 2. Status Register 1 (SR1) [SRAM, E0h]

BIT	R/W	POWER-UP DEFAULT	NAME	FUNCTION
0	R	0	FAULT_RT	Fault Condition—Real Time. A real-time bit that indicates the current operating status of channel 1. 0 = Normal condition 1 = Fault condition
1	R	0	FAULT_L	Fault Condition—Latched. A latched bit that is set when the channel enters a fault condition. This bit is cleared when read, regardless of the current state of fault.
2	R	0	STO_L	Lamp Strike Timeout—Latched. A latched bit that is set when the lamp fails to strike. This bit is cleared when read.
3	R	0	OV_L	Overvoltage—Latched. A latched bit that is set when a lamp overvoltage is present for at least 64 lamp cycles. This bit is cleared when read.
4	R	0	LOUT_L	Lamp Out—Latched. A latched bit that is set when a lamp out is detected. This bit is cleared when read.
5	R	0	LOC_L	Lamp Overcurrent—Latched. A latched bit that is set when a lamp overcurrent is detected. This bit is cleared when read.
6	R	0	SVML_RT	Supply Voltage Monitor Low—Real Time. A real-time bit that reports the comparator output of the SVML pin.
7	R	0	SVMH_RT	Supply Voltage Monitor High—Real Time. A real-time bit that reports the comparator output of the SVMH pin.

Note 1: Writing to this register has no effect on it.

Note 2: See Figure 8 for more details on how the status bits are set.

Note 3: SR1 is cleared when only the following occurs:

- VCC drops below the UVLO threshold.
- The SVML or SVMH thresholds are crossed.
- The PDN hardware pin goes high.
- The PDNE software bit is written to a logic 1.
- The channel is disabled by the CH1D control bit.

Table 3. Brightness Lamp Current Register (BLC) [SRAM, E3h]

BIT	R/W	FACTORY DEFAULT	NAME	FUNCTION
0	R/W	0	LC0	These five control bits determine the target value for the lamp current. 11111b is 35% of the nominal level and 00000b is 100% of the nominal level. These control bits are used for fine adjustment of the lamp brightness.
1	R/W	0	LC1	
2	R/W	0	LC2	
3	R/W	0	LC3	
4	R/W	0	LC4	
5	R/W	0	CH1D	Channel 1 Disable 0 = Channel 1 enabled 1 = Channel 1 disabled
6	R/W	0	RSVD	Reserved. Should be set to 0.
7	R/W	0	SEEB	SRAM-Shadowed EEPROM Write Control 0 = Enables writes to EEPROM 1 = Disables writes to EEPROM

Single-Channel Automotive CCFL Controller

DS3881

Table 4a. Soft-Start Protocol Registers (SSPx) [Shadowed-EEPROM, F0h, F1h, F2h, F3h]

SSP#	ADDR	FACTORY DEFAULT	MSB				LSB			
			7	6	5	4	3	2	1	0
SSP1	F0h	21h	LST1	Lamp Cycles 3 and 4		LST0	Lamp Cycles 1 and 2			
SSP2	F1h	43h	RSVD	Lamp Cycles 7 and 8		RSVD	Lamp Cycles 5 and 6			
SSP3	F2h	65h	RSVD	Lamp Cycles 11 and 12		RSVD	Lamp Cycles 9 and 10			
SSP4	F3h	77h	RSVD	Lamp Cycles 15 and 16		RSVD	Lamp Cycles 13 and 14			

Table 4b. MOSFET Duty Cycle (MDC)—Codes for Soft-Start Settings

BIT	R/W	NAME	FUNCTION																							
0	R/W	MDC0	<p>MDC0/1/2/3: These bits determine a MOSFET duty cycle that repeats twice in the 16 lamp cycle soft-start.</p> <table border="1"> <thead> <tr> <th>MDC CODE</th> <th>MOSFET DUTY CYCLE</th> <th>MDC CODE</th> <th>MOSFET DUTY CYCLE</th> </tr> </thead> <tbody> <tr> <td>0h</td> <td>Fixed at 0%</td> <td>4h</td> <td>Fixed at 13%</td> </tr> <tr> <td>1h</td> <td>Fixed at 3%</td> <td>5h</td> <td>Fixed at 16%</td> </tr> <tr> <td>2h</td> <td>Fixed at 6%</td> <td>6h</td> <td>Fixed at 19%</td> </tr> <tr> <td>3h</td> <td>Fixed at 9%</td> <td>7h</td> <td>Most Recent Value</td> </tr> </tbody> </table>				MDC CODE	MOSFET DUTY CYCLE	MDC CODE	MOSFET DUTY CYCLE	0h	Fixed at 0%	4h	Fixed at 13%	1h	Fixed at 3%	5h	Fixed at 16%	2h	Fixed at 6%	6h	Fixed at 19%	3h	Fixed at 9%	7h	Most Recent Value
MDC CODE	MOSFET DUTY CYCLE	MDC CODE					MOSFET DUTY CYCLE																			
0h	Fixed at 0%	4h					Fixed at 13%																			
1h	Fixed at 3%	5h					Fixed at 16%																			
2h	Fixed at 6%	6h					Fixed at 19%																			
3h	Fixed at 9%	7h					Most Recent Value																			
1	R/W	MDC1																								
2	R/W	MDC2																								
3	R/W	LST0 / RSVD																								
4	R/W	MDC0																								
5	R/W	MDC1	<p>LST0/1: These bits select strike and lamp out timeout. LST0 and LST1 control fault behavior for all lamps.</p> <table border="1"> <thead> <tr> <th>LST1</th> <th>LST0</th> <th>STRIKE AND LAMP OUT TIMEOUT (LAMP FREQUENCY CYCLES)</th> <th>EXAMPLE TIMEOUT IF LAMP FREQUENCY IS 50kHz</th> </tr> </thead> <tbody> <tr> <td>0</td> <td>0</td> <td>32,768</td> <td>0.66 seconds</td> </tr> <tr> <td>0</td> <td>1</td> <td>65,536</td> <td>1.31 seconds</td> </tr> <tr> <td>1</td> <td>0</td> <td>98,304</td> <td>1.97 seconds</td> </tr> <tr> <td>1</td> <td>1</td> <td>Reserved</td> <td>—</td> </tr> </tbody> </table>				LST1	LST0	STRIKE AND LAMP OUT TIMEOUT (LAMP FREQUENCY CYCLES)	EXAMPLE TIMEOUT IF LAMP FREQUENCY IS 50kHz	0	0	32,768	0.66 seconds	0	1	65,536	1.31 seconds	1	0	98,304	1.97 seconds	1	1	Reserved	—
LST1	LST0	STRIKE AND LAMP OUT TIMEOUT (LAMP FREQUENCY CYCLES)					EXAMPLE TIMEOUT IF LAMP FREQUENCY IS 50kHz																			
0	0	32,768					0.66 seconds																			
0	1	65,536					1.31 seconds																			
1	0	98,304					1.97 seconds																			
1	1	Reserved	—																							
6	R/W	MDC2																								
7	R/W	LST1 / RSVD																								

Single-Channel Automotive CCFL Controller

DS3881

Table 5. Control Register 1 (CR1) [Shadowed-EEPROM, F4h]

BIT	R/W	FACTORY DEFAULT	NAME	FUNCTION
0	R/W	0	LOCE	Lamp Overcurrent Enable 0 = Lamp overcurrent detection disabled. 1 = Lamp overcurrent detection enabled.
1	R/W	0	POSCS	POSC Select. See POSCR0 and POSCR1 control bits in Control Register 2 to select the oscillator range. 0 = POSC input is connected with a resistor to ground to set the frequency of the internal PWM oscillator. 1 = POSC input is a 22.5Hz to 440Hz clock.
2	R/W	0	LFSS	Lamp Frequency Source Select 0 = Lamp frequency generated internally and sourced from the LSYNC output. 1 = Lamp frequency generated externally and supplied to the LSYNC input.
3	R/W	0	DPSS	DPWM Signal Source Select 0 = DPWM signal generated internally and sourced from the PSYNC output. 1 = DPWM signal generated externally and supplied to the PSYNC input.
4	R/W	0	RGSO	Ramp Generator Source Option 0 = Source DPWM at the PSYNC output. 1 = Source internal ramp generator at the PSYNC output.
5	R/W	0	ARD	Autoretry Disable 0 = Autoretry function enabled. 1 = Autoretry function disabled.
6	R/W	0	RSVD	Reserved. Should be set to 0.
7	R/W	0	DPD	DPWM Disable 0 = DPWM function enabled. 1 = DPWM function disabled.

Single-Channel Automotive CCFL Controller

DS3881

Table 6. Control Register 2 (CR2) [Shadowed-EEPROM, F5h]

BIT	R/W	DEFAULT	NAME	FUNCTION																				
0	R/W	0	UMWP	User Memory Write Protect 0 = Write access blocked. 1 = Write access permitted.																				
1	R/W	0	POSCR0	DPWM Oscillator Range Select. When using an external source for the dimming clock, these bits must be set to match the external oscillator's frequency. When using a resistor to set the dimming frequency, these bits plus the external resistor control the frequency.																				
2	R/W	0	POSCR1	<table border="1"> <thead> <tr> <th>POSCR1</th> <th>POSCR0</th> <th>DIMMING CLOCK (DPWM) FREQUENCY RANGE (Hz)</th> <th>k (kΩ • kHz)</th> </tr> </thead> <tbody> <tr> <td>0</td> <td>0</td> <td>22.5 to 55.0</td> <td>1</td> </tr> <tr> <td>0</td> <td>1</td> <td>45 to 110</td> <td>2</td> </tr> <tr> <td>1</td> <td>0</td> <td>90 to 220</td> <td>4</td> </tr> <tr> <td>1</td> <td>1</td> <td>180 to 440</td> <td>8</td> </tr> </tbody> </table>	POSCR1	POSCR0	DIMMING CLOCK (DPWM) FREQUENCY RANGE (Hz)	k (kΩ • kHz)	0	0	22.5 to 55.0	1	0	1	45 to 110	2	1	0	90 to 220	4	1	1	180 to 440	8
POSCR1	POSCR0	DIMMING CLOCK (DPWM) FREQUENCY RANGE (Hz)	k (kΩ • kHz)																					
0	0	22.5 to 55.0	1																					
0	1	45 to 110	2																					
1	0	90 to 220	4																					
1	1	180 to 440	8																					
3	R/W	1	LSR0	Lamp Sample Rate Select. Determines the feedback sample rate of the LCM inputs.																				
4	R/W	0	LSR1	<table border="1"> <thead> <tr> <th>LSR1</th> <th>LSR0</th> <th>SELECTED LAMP SAMPLE RATE</th> <th>EXAMPLE SAMPLE RATE IF LAMP FREQUENCY IS 50kHz</th> </tr> </thead> <tbody> <tr> <td>0</td> <td>0</td> <td>4 Lamp Frequency Cycles</td> <td>12,500Hz</td> </tr> <tr> <td>0</td> <td>1</td> <td>8 Lamp Frequency Cycles</td> <td>6250Hz</td> </tr> <tr> <td>1</td> <td>0</td> <td>16 Lamp Frequency Cycles</td> <td>3125Hz</td> </tr> <tr> <td>1</td> <td>1</td> <td>32 Lamp Frequency Cycles</td> <td>1563Hz</td> </tr> </tbody> </table>	LSR1	LSR0	SELECTED LAMP SAMPLE RATE	EXAMPLE SAMPLE RATE IF LAMP FREQUENCY IS 50kHz	0	0	4 Lamp Frequency Cycles	12,500Hz	0	1	8 Lamp Frequency Cycles	6250Hz	1	0	16 Lamp Frequency Cycles	3125Hz	1	1	32 Lamp Frequency Cycles	1563Hz
LSR1	LSR0	SELECTED LAMP SAMPLE RATE	EXAMPLE SAMPLE RATE IF LAMP FREQUENCY IS 50kHz																					
0	0	4 Lamp Frequency Cycles	12,500Hz																					
0	1	8 Lamp Frequency Cycles	6250Hz																					
1	0	16 Lamp Frequency Cycles	3125Hz																					
1	1	32 Lamp Frequency Cycles	1563Hz																					
5	—	0	RSVD	Reserved. This bit should be set to zero.																				
6	—	0	RSVD	Reserved. This bit should be set to zero.																				
7	R/W	0	PDNE	Power-Down. Logically ORed with the PDN pin. Setting this bit high resets the controller, clears the fault logic, and places the part in power-down mode. 0 = Normal. All circuitry is off, except I ² C interface.																				

Single-Channel Automotive CCFL Controller

Table 7. EMI Control Register (EMIC) [Shadowed-EEPROM, F6h]

BIT	R/W	FACTORY DEFAULT	NAME	FUNCTION				
0	R/W	0	SS0	LAMP OSCILLATOR SPREAD-SPECTRUM MODULATION SELECT				
				SS1	SS0	SELECTED LAMP FREQUENCY SPREAD		
				0	0	SPREAD-SPECTRUM DISABLED		
				0	1	±1.5%		
1	R/W	0	SS1	1	0	±3.0%		
				1	1	±6.0%		
2	R/W	0	SSM	Lamp Oscillator Spread-Spectrum Modulation Select 0 = Triangular modulation. 1 = Pseudorandom modulation.				
3	—	—	RSVD	Reserved. This bit should be set to zero.				
4	R/W	0	STEPE	Lamp Frequency Step Enable. Logically ORed with the step invoked. 0 = Lamp operates at nominal frequency. 1 = Frequency step invoked.				
5	R/W	0	FS0	LAMP OSCILLATOR FREQUENCY STEP SELECT				
				FS2	FS1	FS0	SELECTED LAMP FREQUENCY STEP (SS0 = 0 AND SS1 = 0)	SPREAD-SPECTRUM MODULATION RATE (SS0 AND/OR SS1 = 1)
6	R/W	0	FS1	0	0	0	Step Up 1%	Lamp Frequency x4
				0	0	1	Step Up 2%	Lamp Frequency x2
				0	1	0	Step Up 3%	Lamp Frequency x1
				0	1	1	Step Up 4%	Lamp Frequency x1/2
				1	0	0	Step Down 1%	Lamp Frequency x1/4
7	R/W	0	FS2	1	0	1	Step Down 2%	Lamp Frequency x1/8
				1	1	0	Step Down 3%	Lamp Frequency x1/16
				1	1	1	Step Down 4%	Lamp Frequency x1/32

Single-Channel Automotive CCFL Controller

DS3881

Table 8. Lamp Current Overdrive Control Register (LCOC) [Shaded-EEPROM, F7h]

BIT	R/W	FACTORY DEFAULT	NAME	FUNCTION					
				LAMP CURRENT OVERDRIVE SELECT					
0	R/W	0	LCO0	LCO2	LCO1	LCO0	SELECTED LAMP CURRENT OVERDRIVE		
				0	0	0	Nominal Current + 12.50%		
				0	0	1	Nominal Current + 25.00%		
1	R/W	0	LCO1	0	1	0	Nominal Current + 37.50%		
				0	1	1	Nominal Current + 50.00%		
				1	0	0	Nominal Current + 62.50%		
2	R/W	0	LCO2	1	0	1	Nominal Current + 75.00%		
				1	1	0	Nominal Current + 87.50%		
				1	1	1	Nominal Current + 100.00%		
3	R/W	0	LCOE	Lamp Current Overdrive Enable. Logically ORed with the LCO pin. 0 = Lamp operated with nominal current setting. 1 = Lamp overdrive invoked.					
4	R/W	0	TO0	AUTOMATIC LAMP CURRENT OVERDRIVE TIMEOUT SELECT					
				TO3	TO2	TO1	TO0	SELECTED TIMEOUT IN LAMP FREQUENCY CYCLES	EXAMPLE TIMEOUT IF LAMP FREQUENCY IS 50kHz
5	R/W	0	TO1	0	0	0	0	Disabled	—
				0	0	1	0	1×2^{22}	1.4 min
				0	0	1	1	2×2^{22}	2.8 min
				0	1	0	0	3×2^{22}	4.2 min
				0	1	0	1	4×2^{22}	5.6 min
6	R/W	0	TO2	0	1	1	0	5×2^{22}	7.0 min
				0	1	1	1	6×2^{22}	8.4 min
				1	0	0	0	7×2^{22}	9.8 min
				1	0	0	1	8×2^{22}	11.2 min
				1	0	1	0	9×2^{22}	12.6 min
7	R/W	0	TO3	1	0	1	1	10×2^{22}	14.0 min
				1	0	1	1	11×2^{22}	15.4 min
				1	1	0	0	12×2^{22}	16.8 min
				1	1	0	1	13×2^{22}	18.2 min
				1	1	1	0	14×2^{22}	19.6 min
				1	1	1	1	15×2^{22}	21.0 min

Single-Channel Automotive CCFL Controller

I²C Definitions

The following terminology is commonly used to describe I²C data transfers:

Master Device: The master device controls the slave devices on the bus. The master device generates SCL clock pulses, start, and stop conditions.

Slave Devices: Slave devices send and receive data at the master's request.

Bus Idle or Not Busy: Time between stop and start conditions when both SDA and SCL are inactive and in their logic-high states.

Start Condition: A start condition is generated by the master to initiate a new data transfer with a slave. Transitioning SDA from high to low while SCL remains high generates a start condition. See the timing diagram for applicable timing.

Stop Condition: A stop condition is generated by the master to end a data transfer with a slave. Transitioning SDA from low to high while SCL remains high generates a stop condition. See the timing diagram for applicable timing.

Repeated Start Condition: The master can use a repeated start condition at the end of one data transfer to indicate that it will immediately initiate a new data transfer following the current one. Repeated starts are commonly used during read operations to identify a specific memory address to begin a data transfer. A repeated start condition is issued identically to a normal start condition. See the timing diagram for applicable timing.

Bit Write: Transitions of SDA must occur during the low state of SCL. The data on SDA must remain valid and unchanged during the entire high pulse of SCL plus the setup and hold time requirements (see Figure 9). Data is shifted into the device during the rising edge of the SCL.

Bit Read: At the end of a write operation, the master must release the SDA bus line for the proper amount of setup time (see Figure 9) before the next rising edge of SCL during a bit read. The device shifts out each bit of data on SDA at the falling edge of the previous SCL pulse and the data bit is valid at the rising edge of the current SCL pulse. Remember that the master generates all SCL clock pulses including when it is reading bits from the slave.

Acknowledgement (ACK and NACK): An acknowledgement (ACK) or not acknowledge (NACK) is always the 9th bit transmitted during a byte transfer. The device receiving data (the master during a read or the slave during a write operation) performs an ACK by transmitting a zero during the 9th bit. A device performs a NACK by transmitting a one during the 9th bit. Timing (Figure 9) for the ACK and NACK is identical to all other bit writes. An ACK is the acknowledgment that the device is properly receiving data. A NACK is used to terminate a read sequence or as an indication that the device is not receiving data.

Byte Write: A byte write consists of 8 bits of information transferred from the master to the slave (most significant bit first) plus a 1-bit acknowledgement from the slave to the master. The 8 bits transmitted by the master are done according to the bit-write definition and the acknowledgement is read using the bit-read definition.

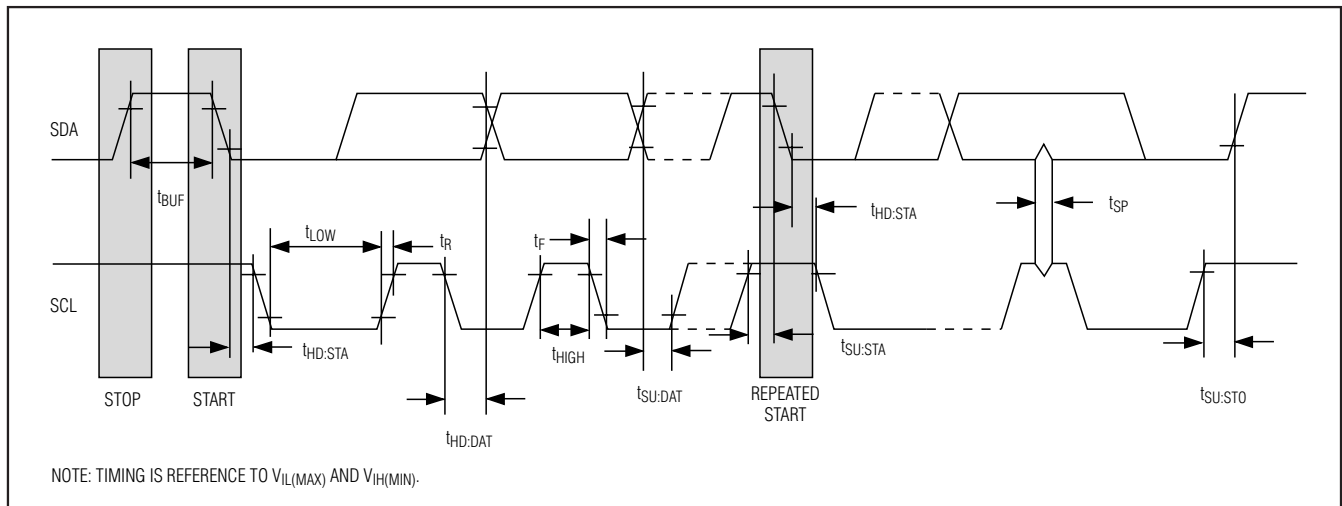

Figure 9. I²C Timing Diagram

Single-Channel Automotive CCFL Controller

Byte Read: A byte read is an 8-bit information transfer from the slave to the master plus a 1-bit ACK or NACK from the master to the slave. The 8 bits of information that are transferred (most significant bit first) from the slave to the master are read by the master using the bit read definition above, and the master transmits an ACK using the bit write definition to receive additional data bytes. The master must NACK the last byte read to terminate communication so the slave will return control of SDA to the master.

Slave Address Byte: Each slave on the I²C bus responds to a slave addressing byte sent immediately following a start condition. The slave address byte (Figure 10) contains the slave address in the most significant seven bits and the R/W bit in the least significant bit. The DS3881's slave address is 10100A₁A₀0 (binary), where A₀ and A₁ are the values of the address pins (A0 and A1). The address pin allows the device to respond to one of four possible slave addresses. By writing the correct slave address with R/W = 0, the master indicates it will write data to the slave. If R/W = 1, the master will read data from the slave. If an incorrect slave address is written, the DS3881 will assume the master is communicating with another I²C device and ignore the communications until the next start condition is sent.

Memory Address: During an I²C write operation, the master must transmit a memory address to identify the memory location where the slave is to store the data. The memory address is always the second byte transmitted during a write operation following the slave address byte.

I²C Communication

Writing a Data Byte to a Slave: The master must generate a start condition, write the slave address byte (R/W = 0), write the memory address, write the byte of data, and generate a stop condition. Remember the master must read the slave's acknowledgement during all byte write operations. See Figure 11 for more detail.

Acknowledge Polling: Any time EEPROM is written, the DS3881 requires the EEPROM write time (t_W) after the stop condition to write the contents to EEPROM. During the EEPROM write time, the DS3881 will not acknowledge its slave address because it is busy. It is possible to take advantage of that phenomenon by repeatedly addressing the DS3881, which allows the next byte of data to be written as soon as the DS3881 is ready to receive the data. The alternative to acknowledge polling is to wait for a maximum period of t_W to elapse before attempting to write again to the DS3881.

EEPROM Write Cycles: The number of times the DS3881's EEPROM can be written before it fails is specified in the *Nonvolatile Memory Characteristics* table. This specification is shown at the worst-case write temperature. The DS3881 is typically capable of handling many additional write cycles when the writes are performed at room temperature.

Reading a Data Byte from a Slave: To read a single byte from the slave the master generates a start condition, writes the slave address byte with R/W = 0, writes the memory address, generates a repeated start condition, writes the slave address with R/W = 1, reads the data byte with a NACK to indicate the end of the transfer, and generates a stop condition. See Figure 11 for more detail.

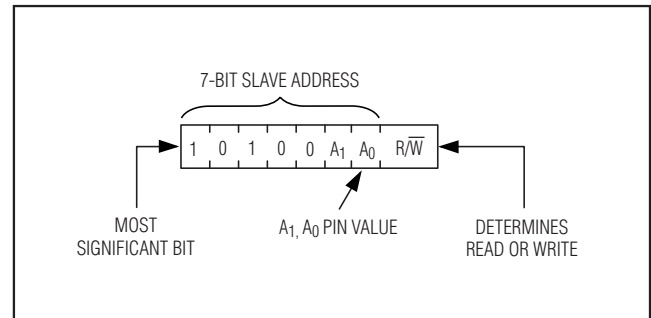

Figure 10. DS3881's Slave Address Byte

Single-Channel Automotive CCFL Controller

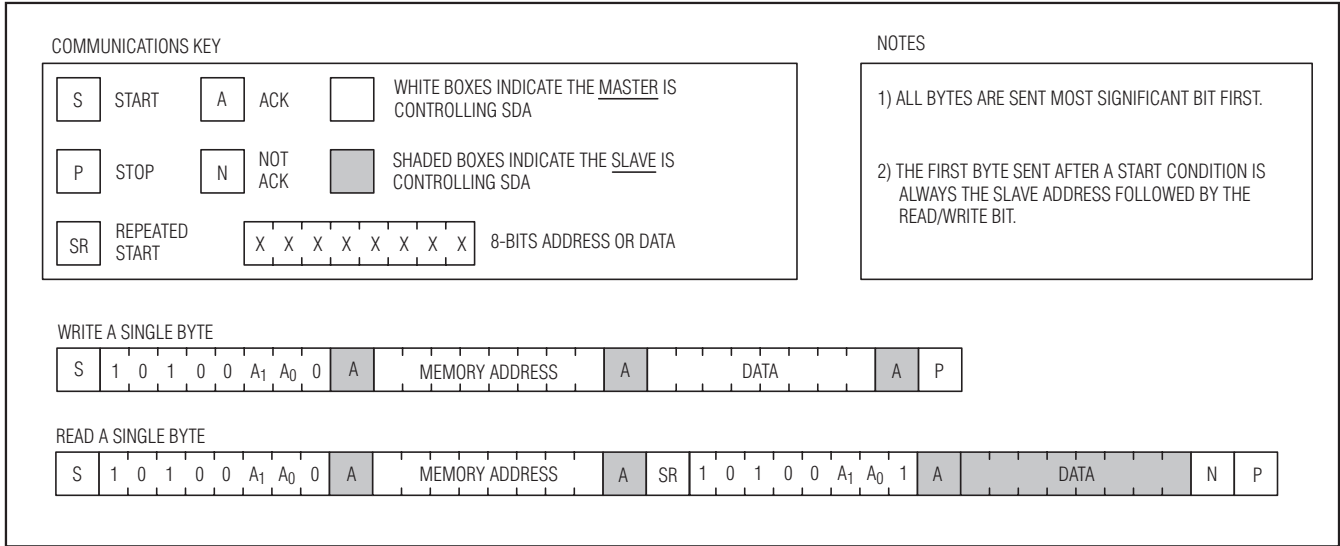

Figure 11. I²C Communications Examples

Applications Information

Addressing Multiple DS3881s On a Common I²C Bus

Each DS3881 responds to one of four possible slave addresses based on the state of the address input pins (A0 and A1). For information about device addressing, see the *I²C Communication* section.

Setting the RMS Lamp Current

Resistor R7 and R8 in the *Typical Operating Circuit* set the lamp current. R7 and R8 = 140Ω corresponds to a 5mA_{RMS} lamp current as long as the current waveform is approximately sinusoidal. The formula to determine the resistor value for a given sinusoidal lamp current is:

$$R_7 = \frac{1}{I_{LAMP(RMS)} \times \sqrt{2}}$$

Component Selection

External component selection has a large impact on the overall system performance and cost. The two most important external components are the transformers and n-channel MOSFETs.

The transformer should be able to operate in the 40kHz to 80kHz frequency range of the DS3881, and the turns ratio should be selected so the MOSFET drivers run at 28% to 35% duty cycle during steady state operation. The transformer must be able to withstand the high open-circuit voltage that is used to strike the lamp.

Additionally, its primary/secondary resistance and inductance characteristics must be considered because they contribute significantly to determining the efficiency and transient response of the system. Table 9 shows a transformer specification that has been used for a 12V inverter supply, 438mm x 2.2mm lamp design.

The n-channel MOSFET must have a threshold voltage that is low enough to work with logic-level signals, a low on-resistance to maximize efficiency and limit the n-channel MOSFET's power dissipation, and a breakdown voltage high enough to handle the transient. The breakdown voltage should be a minimum of 3x the inverter voltage supply. Additionally, the total gate charge must be less than Q_G, which is specified in the *Recommended Operating Conditions* table. These specifications are easily met by many of the dual n-channel MOSFETs now available in 8-pin SO packages.

Table 10 lists suggested values for the external resistors and capacitors used in the *Typical Operating Circuit*.

Power-Supply Decoupling

To achieve best results, it is highly recommended that a decoupling capacitor is used on the IC power-supply pin. Typical values of decoupling capacitors are 0.01μF or 0.1μF. Use a high-quality, ceramic, surface-mount capacitor, and mount it as close as possible to the V_{CC} and GND pins of the IC to minimize lead inductance.

Single-Channel Automotive CCFL Controller

DS3881

Table 9. Transformer Specifications (as Used in the Typical Operating Circuit)

PARAMETER	CONDITIONS	MIN	TYP	MAX	UNITS
Turns Ratio (Secondary/Primary)	(Notes 1, 2, 3)		40		
Frequency		40		80	kHz
Output Power				6	W
Output Current			5	8	mA
Primary DCR	Center tap to one end		200		mΩ
Secondary DCR			500		Ω
Primary Leakage			12		μH
Secondary Leakage			185		mH
Primary Inductance			70		μH
Secondary Inductance			500		mH
Secondary Output Voltage	100ms minimum	2000			V _{RMS}
	Continuous	1000			

Note 1: Primary should be Bifilar wound with center tap connection.

Note 2: Turns ratio is defined as secondary winding divided by the sum of both primary windings.

Note 3: 40:1 is the nominal turns ratio for driving a 438mm x 2.2mm lamp with a 12V supply. Refer to Application Note 3375 for more information.

Table 10. Resistor and Capacitor Selection Guide

DESIGNATOR	QTY	VALUE	TOLERANCE (%) AT +25°C	TEMPERATURE COEFFICIENT	NOTES
R5, R6	1	10kΩ	1	—	—
R3, R4	1	12.5kΩ to 105kΩ	1	—	See the <i>Setting the SVM Threshold Voltage</i> section.
R9	1	20kΩ to 40kΩ	1	≤153ppm/°C	2% or less total tolerance. See the <i>Lamp Frequency Configuration</i> section to determine value.
R10	1	18kΩ to 45kΩ	1	≤153ppm/°C	2% or less total tolerance. See the <i>Lamp Frequency Configuration</i> section to determine value.
R1	1	4.7kΩ	5	Any grade	—
R2	1	4.7kΩ	5	Any grade	—
R11	1	4.7kΩ	5	Any grade	—
R7	1/Chan	140Ω	1	—	See the <i>Setting the RMS Lamp Current</i> section.
C8	1/Chan	100nF	10	X7R	Capacitor value will also affect LCM bias voltage during power-up. A larger capacitor may cause a longer time for V _{DCB} to reach its normal operating level.
C2	1/Chan	10pF	5	±1000ppm/°C	2kV to 4kV breakdown voltage required.
C3	1/Chan	27nF	5	X7R	Capacitor value will also affect LCM bias voltage during power-up. A larger capacitor may cause a longer time for V _{DCB} to reach its normal operating level.
C1	1/Chan	33μF	20	Any grade	—
C7	2/DS3881	0.1μF	10	X7R	Place close to V _{CC} and GND on DS3881.

Single-Channel Automotive CCFL Controller

Typical Operating Circuit

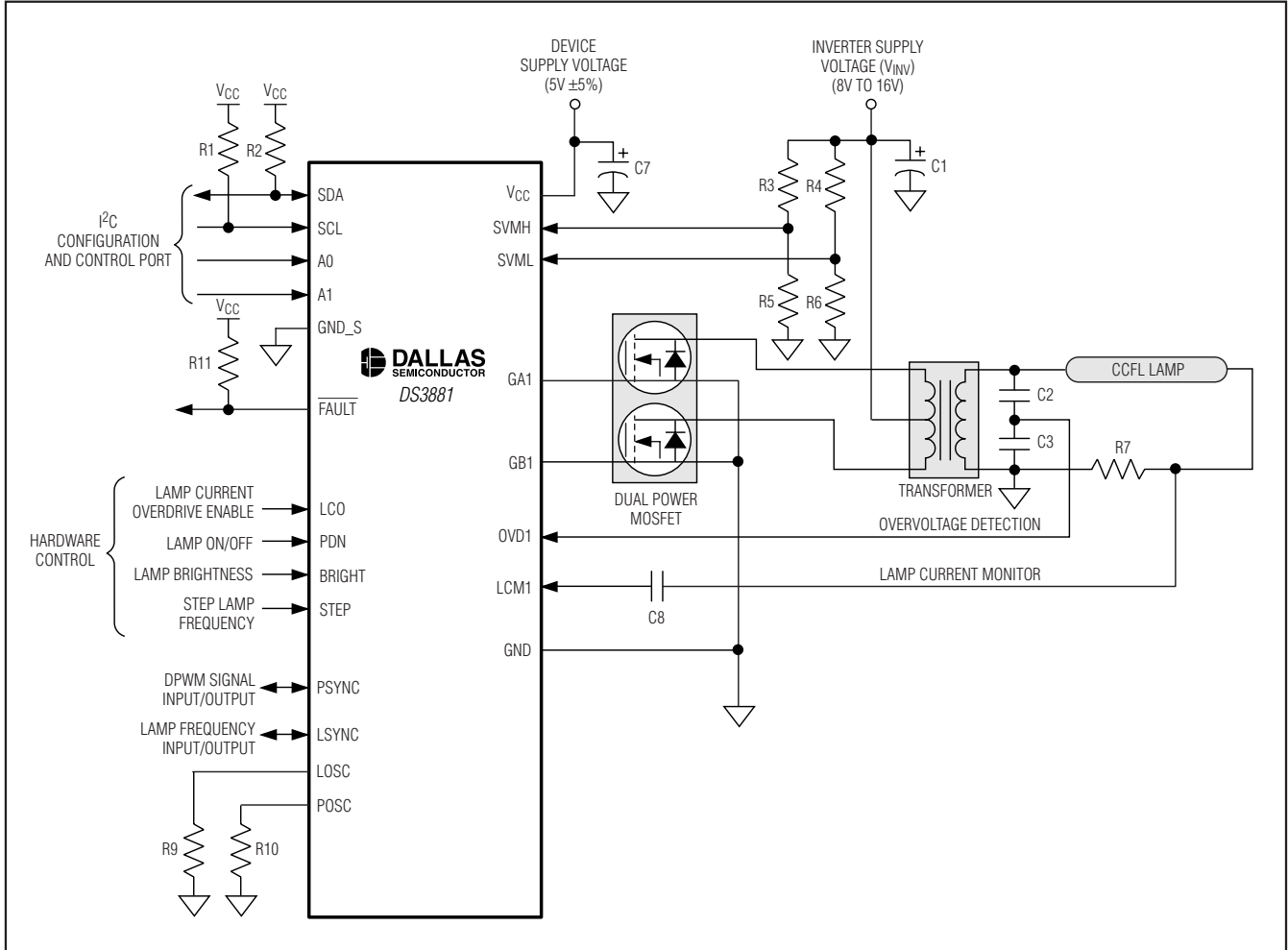

Chip Information

TRANSISTOR COUNT: 38,000
 SUBSTRATE CONNECTED TO GROUND

Package Information

For the latest package outline information, go to
www.maxim-ic.com/DallasPackInfo.

Revision History

Pages changed at Rev 1: 1, 19

Maxim cannot assume responsibility for use of any circuitry other than circuitry entirely embodied in a Maxim product. No circuit patent licenses are implied. Maxim reserves the right to change the circuitry and specifications without notice at any time.

28 **Maxim Integrated Products, 120 San Gabriel Drive, Sunnyvale, CA 94086 408-737-7600**



© 2007 Maxim Integrated Products

MAXIM is a registered trademark of Maxim Integrated Products, Inc.

DALLAS SEMICONDUCTOR is a registered trademark of Dallas Semiconductor Corporation.

Looking for pricing, stock, or lifecycle information?

Click below to explore more details on WIN SOURCE:

-  [View DS3881E+T&R/C on WIN SOURCE](#)
-  [Maxim Integrated Information](#)

Optimize Your Supply Chain with WIN SOURCE Solutions

-  Global Sourcing Solution
-  Obsolete Management
-  Cost Control Management
-  Shortage Management
-  Alternative Solution
-  Excess Inventory Management