



**THE DATASHEET OF  
CY28547LFXC**



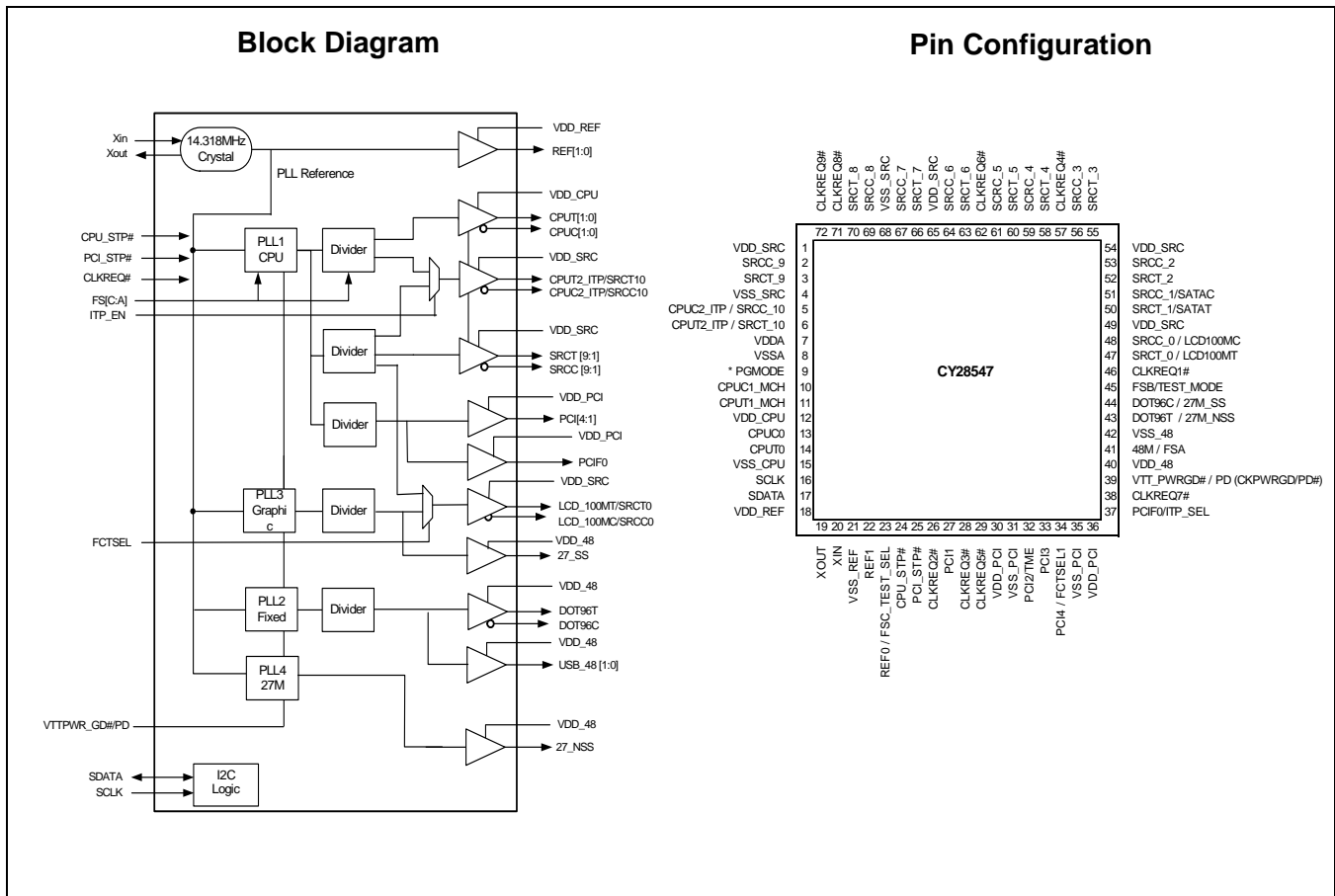
# Clock Generator for Intel® CK410M/CK505

## Features

- Compliant to Intel® CK410M and CK505
- Selectable CPU frequencies
- Low power differential CPU clock pairs
- 100-MHz low power differential SRC clocks
- 96-MHz low power differential dot clock
- 27-MHz Spread and Non-spread video clock
- 48-MHz USB clock
- SRC clocks independently stoppable through CLKREQ#[1:9]
- 96/100-MHz low power spreadable differential video clock
- 33-MHz PCI clocks
- Buffered Reference Clock 14.318 MHz
- Low-voltage frequency select inputs
- I<sup>2</sup>C support with readback capabilities
- Ideal Lexmark Spread Spectrum profile for maximum electromagnetic interference (EMI) reduction
- 3.3V power supply
- 72-pin QFN package

Table 1. Output Configuration Table

CPU	SRC	PCI	REF	DOT96	USB_48M	LCD	27M
x2/x3	x9/11	x5	x 2	x 1	x 1	x1	x2



**Pin Description**

Pin No.	Name	Type	Description									
1, 49, 54, 65	VDD_SRC	PWR	3.3V power supply for outputs.									
2, 3, 52, 53, 55, 56, 58, 59, 60, 61, 63, 64, 66, 67, 69, 70	SRCT/C[2:9]	O, DIF	100-MHz Differential serial reference clocks.									
4, 68	VSS_SRC	GND	Ground for outputs.									
5, 6	CPUT2_ITP/SRCT10, CPUC2_ITP/SRCC10	O, DIF	Selectable differential CPU or SRC clock output. ITP_SEL = 0 @ pin 39 assertion = SRC10 ITP_SEL = 1 @ pin 39 assertion = CPU2									
7	VDDA	PWR	3.3V power supply for PLL.									
8	VSSA	GND	Ground for PLL.									
9	PGMODE	I, PU	3.3V LVTTTL input for selecting the polarity of pin 39 Internal pull-up resistor of 100K to 3.3V, use 10K resistor to pull it low externally if needed  <table border="1" data-bbox="867 766 1323 888"> <thead> <tr> <th>PGMODE</th> <th>CLK mode</th> <th>Pin 39</th> </tr> </thead> <tbody> <tr> <td>0</td> <td>CK410</td> <td>VTT_PWRGD#/PD</td> </tr> <tr> <td>1(default)</td> <td>CK505</td> <td>CK_PWRGD/PD#</td> </tr> </tbody> </table>	PGMODE	CLK mode	Pin 39	0	CK410	VTT_PWRGD#/PD	1(default)	CK505	CK_PWRGD/PD#
PGMODE	CLK mode	Pin 39										
0	CK410	VTT_PWRGD#/PD										
1(default)	CK505	CK_PWRGD/PD#										
10, 11	CPUC1_MCH, CPUT1_MCH	O, DIF	Differential CPU clock output to MCH									
12	VDD_CPU	PWR	3.3V power supply for outputs.									
13, 14	CPU[T/C]0	O, DIF	Differential CPU clock output									
15	VSS_CPU	GND	Ground for outputs.									
16	SCLK	I	SMBus-compatible SCLOCK.									
17	SDATA	I/O, OD	SMBus-compatible SDATA.									
18	VDD_REF	PWR	3.3V power supply for outputs.									
19	XOUT	O, SE	14.318-MHz crystal output.									
20	XIN	I	14.318-MHz crystal input.									
21	VSS_REF	GND	Ground for outputs.									
22	REF1	O	Fixed 14.318-MHz clock output.									
23	REF0/FSC_TESTSEL	I/O	Fixed 14.318 clock output/3.3V-tolerant input for CPU frequency selection/Selects test mode if pulled to V <sub>IMFS_C</sub> when pin 39 is asserted LOW. Refer to DC Electrical Specifications table for V <sub>ILFS_C</sub> , V <sub>IMFS_C</sub> , V <sub>IHFS_C</sub> specifications.									
24	CPU_STP#	I	3.3V LVTTTL input for CPU_STP# active LOW During direct clock off to M1 mode transition, a serial load of BSEL data is driven on this pin and sampled on the rising edge of PCI_STP#. See Figure 14. for more information.									
25	PCI_STP#	I	3.3V LVTTTL input for PCI_STP# active LOW During direct clock off to M1 mode transition, a serial load of BSEL data is driven on CPU_STP# and sampled on the rising edge of this pin. See Figure 14. for more information.									
26, 28, 29, 38, 46, 57, 62, 71, 72	CLKREQ[1:9]#	I	3.3V LVTTTL input for enabling assigned SRC clock (active LOW).									
27	PCI1	O, SE	33MHz clock output									
30, 36	VDD_PCI	PWR	3.3V power supply for outputs.									
31, 35	VSS_PCI	GND	Ground for outputs.									

**Pin Description** (continued)

Pin No.	Name	Type	Description															
32	PCI2/TME	I/O, SE	33-MHz clock output/Trusted Mode Enable Strap Strap at pin 39 assertion to determine if the part is in trusted mode or not. Internal pull-up resistor of 100K to 3.3V, use 10K resistor to pull it low externally if needed 0 = Normal mode 1 = Trusted mode (default)															
33	PCI3	O, SE	33-MHz clock output															
34	PCI4/FCTSEL1	I/O	33-MHz clock output/3.3V LVTTTL input for selecting pins 47,48 (SRC[T/C]0, 100M[T/C]) and pins 43,44 (DOT96[T/C] and 27M Spread and Non-spread) (sampled on pin 39 assertion). Internal pull-down resistor of 100K to GND <table border="1" data-bbox="701 613 1412 732"> <thead> <tr> <th>FCTSEL1</th> <th>Pin 43</th> <th>Pin 44</th> <th>Pin 47</th> <th>Pin 48</th> </tr> </thead> <tbody> <tr> <td>0</td> <td>DOT96T</td> <td>DOT96C</td> <td>96/100M_T</td> <td>96/100M_C</td> </tr> <tr> <td>1</td> <td>27M_NSS</td> <td>27M_SS</td> <td>SRCT0</td> <td>SRCC0</td> </tr> </tbody> </table>	FCTSEL1	Pin 43	Pin 44	Pin 47	Pin 48	0	DOT96T	DOT96C	96/100M_T	96/100M_C	1	27M_NSS	27M_SS	SRCT0	SRCC0
FCTSEL1	Pin 43	Pin 44	Pin 47	Pin 48														
0	DOT96T	DOT96C	96/100M_T	96/100M_C														
1	27M_NSS	27M_SS	SRCT0	SRCC0														
37	ITP_SEL/PCIF0	I/O,SE	3.3V LVTTTL input to enable SRC10 or CPU2_ITP/33-MHz clock output. (sampled on pin 39 assertion). Internal pull-down resistor of 100K to GND 1 = CPU2_ITP, 0 = SRC10															
39	VTT_PWRGD#/PD CKPWRGD/PD#	I	3.3V LVTTTL input. This pin is a level sensitive strobe. When asserted, according to the polarity defined by pin 9 (PGMODE), it latches data on the FSA, FSB, FSC, FCTSEL1 and ITP_SEL pins. After assertion, it becomes a real time input for controlling power down. <table border="1" data-bbox="709 991 1169 1184"> <thead> <tr> <th>PGMODE</th> <th>Pin 39</th> </tr> </thead> <tbody> <tr> <td>0</td> <td>0 = POWER GOOD (VTT_PWRGD#)</td> </tr> <tr> <td>0</td> <td>1 = POWER DOWN (PD)</td> </tr> <tr> <td>1</td> <td>0 = POWER DOWN (PD#)</td> </tr> <tr> <td>1</td> <td>1 = POWER GOOD (CKPWRGD)</td> </tr> </tbody> </table>	PGMODE	Pin 39	0	0 = POWER GOOD (VTT_PWRGD#)	0	1 = POWER DOWN (PD)	1	0 = POWER DOWN (PD#)	1	1 = POWER GOOD (CKPWRGD)					
PGMODE	Pin 39																	
0	0 = POWER GOOD (VTT_PWRGD#)																	
0	1 = POWER DOWN (PD)																	
1	0 = POWER DOWN (PD#)																	
1	1 = POWER GOOD (CKPWRGD)																	
40	VDD_48	PWR	3.3V power supply for outputs.															
41	48M/FSA	I/O	Fixed 48-MHz clock output/3.3V-tolerant input for CPU frequency selection <i>Refer to DC Electrical Specifications table for Vil_FS and Vih_FS specifications.</i>															
42	VSS_48	GND	Ground for outputs.															
43, 44	DOT96T/ 27M_NSS DOT96C/ 27M_SS	O, DIF	Fixed 96-MHz clock output or 27 Mhz Spread and Non-spread output Selected via FCTSEL1 at pin 39 assertion.															
45	FSB/TEST_MODE	I	3.3V-tolerant input for CPU frequency selection. Selects Ref/N or Tri-state when in test mode 0 = Tri-state, 1 = Ref/N <i>Refer to DC Electrical Specifications table for Vil_FS and Vih_FS specifications.</i>															
47, 48	SRC[T/C]0/ LCD100M[T/C]	O,DIF	100-MHz differential serial reference clock output/Differential 96/100-MHz SS clock for flat-panel display Selected via FCTSEL1 at pin 39 assertion.															
50, 51	SRCT_1/SATAT, SRCC_1/SATAC	O, DIF	100-MHz Differential serial reference clocks.															

**Frequency Select Pins (FSA, FSB, and FSC)**

Host clock frequency selection is achieved by applying the appropriate logic levels to FSA, FSB, FSC inputs prior to VTT\_PWRGD# assertion (as seen by the clock synthesizer). Upon VTT\_PWRGD# being sampled LOW by the clock chip (indicating processor VTT voltage is stable), the clock chip

samples the FSA, FSB, and FSC input values. For all logic levels of FSA, FSB, and FSC, VTT\_PWRGD# employs a one-shot functionality in that once a valid LOW on VTT\_PWRGD# has been sampled, all further VTT\_PWRGD#, FSA, FSB, and FSC transitions will be ignored, except in test mode.

## Serial Data Interface

To enhance the flexibility and function of the clock synthesizer, a two-signal serial interface is provided. Through the Serial Data Interface, various device functions, such as individual clock output buffers, can be individually enabled or disabled. The registers associated with the Serial Data Interface initialize to their default setting upon power-up, and therefore use of this interface is optional. Clock device register changes are normally made upon system initialization, if any are required. The interface cannot be used during system operation for power management functions.

## Data Protocol

The clock driver serial protocol accepts byte write, byte read, block write, and block read operations from the controller. For block write/read operation, the bytes must be accessed in sequential order from lowest to highest byte (most significant bit first) with the ability to stop after any complete byte has been transferred. For byte write and byte read operations, the system controller can access individually indexed bytes. The offset of the indexed byte is encoded in the command code, as described in *Table 3*.

The block write and block read protocol is outlined in *Table 4* while *Table 5* outlines the corresponding byte write and byte read protocol. The slave receiver address is 11010010 (D2h)

**Table 2. Frequency Select Table FSA, FSB, and FSC**

FSC	FSB	FSA	CPU	SRC	PCIF/PCI	27MHz	REF	DOT96	USB
1	0	1	100 MHz	100 MHz	33 MHz	27 MHz	14.318 MHz	96 MHz	48 MHz
0	0	1	133 MHz	100 MHz	33 MHz	27 MHz	14.318 MHz	96 MHz	48 MHz
0	1	1	166 MHz	100 MHz	33 MHz	27 MHz	14.318 MHz	96 MHz	48 MHz
0	1	0	200 MHz	100 MHz	33 MHz	27 MHz	14.318 MHz	96 MHz	48 MHz

**Table 3. Command Code Definition**

Bit	Description
7	0 = Block read or block write operation, 1 = Byte read or byte write operation
(6:0)	Byte offset for byte read or byte write operation. For block read or block write operations, these bits should be '0000000'

**Table 4. Block Read and Block Write Protocol**

Block Write Protocol		Block Read Protocol	
Bit	Description	Bit	Description
1	Start	1	Start
8:2	Slave address–7 bits	8:2	Slave address–7 bits
9	Write	9	Write
10	Acknowledge from slave	10	Acknowledge from slave
18:11	Command Code–8 bits	18:11	Command Code–8 bits
19	Acknowledge from slave	19	Acknowledge from slave
27:20	Byte Count–8 bits (Skip this step if I <sup>2</sup> C_EN bit set)	20	Repeat start
28	Acknowledge from slave	27:21	Slave address–7 bits
36:29	Data byte 1–8 bits	28	Read = 1
37	Acknowledge from slave	29	Acknowledge from slave
45:38	Data byte 2–8 bits	37:30	Byte Count from slave–8 bits
46	Acknowledge from slave	38	Acknowledge
....	Data Byte/Slave Acknowledges	46:39	Data byte 1 from slave–8 bits
....	Data Byte N–8 bits	47	Acknowledge
....	Acknowledge from slave	55:48	Data byte 2 from slave–8 bits
....	Stop	56	Acknowledge
		....	Data bytes from slave/Acknowledge
		....	Data Byte N from slave–8 bits
		....	NOT Acknowledge

**Table 4. Block Read and Block Write Protocol (continued)**

Block Write Protocol		Block Read Protocol	
Bit	Description	Bit	Description
		....	Stop

**Table 5. Byte Read and Byte Write Protocol**

Byte Write Protocol		Byte Read Protocol	
Bit	Description	Bit	Description
1	Start	1	Start
8:2	Slave address–7 bits	8:2	Slave address–7 bits
9	Write	9	Write
10	Acknowledge from slave	10	Acknowledge from slave
18:11	Command Code–8 bits	18:11	Command Code–8 bits
19	Acknowledge from slave	19	Acknowledge from slave
27:20	Data byte–8 bits	20	Repeated start
28	Acknowledge from slave	27:21	Slave address–7 bits
29	Stop	28	Read
		29	Acknowledge from slave
		37:30	Data from slave–8 bits
		38	NOT Acknowledge
		39	Stop

## Control Registers

### Byte 0 Control Register 0

Bit	@Pup	Name	Description
7	0	RESEREVD	RESERVED
6	0	RESEREVD	RESERVED
5	0	RESEREVD	RESERVED
4	0	iAMT_EN	Set via SMBus or by combination of PD, CPU_STP and PCI_STP 0 = Legacy mode, 1 = iAMT enable
3	0	RESEREVD	RESERVED
2	0	RESEREVD	RESERVED
1	0	RESEREVD	RESERVED
0	1	PD_Restore	Save configuration in PD 0 = Configuration cleared, 1 = Configuration saved

### Byte 1 Control Register 1

Bit	@Pup	Name	Description
7	1	SRC[T/C]7	SRC[T/C]7 Output Enable 0 = Disabled, 1 = Enabled
6	1	SRC[T/C]6	SRC[T/C]6 Output Enable 0 = Disabled, 1 = Enabled
5	1	SRC[T/C]5	SRC[T/C]5 Output Enable 0 = Disabled, 1 = Enabled
4	1	SRC[T/C]4	SRC[T/C]4 Output Enable 0 = Disabled, 1 = Enabled
3	1	SRC[T/C]3	SRC[T/C]3 Output Enable 0 = Disabled, 1 = Enabled

**Byte 1 Control Register 1 (continued)**

Bit	@Pup	Name	Description
2	1	SRC[T/C]2	SRC[T/C]2 Output Enable 0 = Disabled, 1 = Enabled
1	1	SRC[T/C]1	SRC[T/C]1 Output Enable 0 = Disabled, 1 = Enabled
0	1	SRC[T/C]0 /LCD_96_100M[T/C]	SRC[T/C]0/LCD_96_100M[T/C] Output Enable 0 = Disabled, 1 = Enabled

**Byte 2 Control Register 2**

Bit	@Pup	Name	Description
7	1	PCIF0	PCIF0 Output Enable 0 = Disabled, 1 = Enabled
6	1	27M NSS/DOT_96[T/C]	27M Non-spread and DOT_96 MHz Output Enable 0 = Disable, 1 = Enabled
5	1	48M	48-MHz Output Enable 0 = Disabled, 1 = Enabled
4	1	REF0	REF0 Output Enable 0 = Disabled, 1 = Enabled
3	1	REF1	REF1 Output Enable 0 = Disabled, 1 = Enabled
2	1	CPU[T/C]1	CPU[T/C]1 Output Enable 0 = Disabled, 1 = Enabled
1	1	CPU[T/C]0	CPU[T/C]0 Output Enable 0 = Disabled, 1 = Enabled
0	1	CPU, SRC, PCI, PCIF Spread Enable	PLL1 (CPU PLL) Spread Spectrum Enable 0 = Spread off, 1 = Spread on

**Byte 3 Control Register 3**

Bit	@Pup	Name	Description
7	1	PCI4	PCI4 Output Enable 0 = Disabled, 1 = Enabled
6	1	PCI3	PCI3 Output Enable 0 = Disabled, 1 = Enabled
5	1	PCI2	PCI2 Output Enable 0 = Disabled, 1 = Enabled
4	1	PCI1	PCI1 Output Enable 0 = Disabled, 1 = Enabled
3	1	RESERVED	RESERVED
2	1	RESERVED	RESERVED
1	1	CPU[T/C]2/SRC[T/C]10	CPU[T/C]2/SRC[T/C]10 Output Enable 0 = Disabled, 1 = Enabled
0	1	RESERVED	RESERVED

**Byte 4 Control Register 4**

Bit	@Pup	Name	Description
7	0	SRC7	Allow control of SRC[T/C]7 with assertion of PCI_STP# or SW PCI_STP# 0 = Free running, 1 = Stopped with PCI_STP#
6	0	SRC6	Allow control of SRC[T/C]6 with assertion of PCI_STP# or SW PCI_STP# 0 = Free running, 1 = Stopped with PCI_STP#
5	0	SRC5	Allow control of SRC[T/C]5 with assertion of PCI_STP# or SW PCI_STP# 0 = Free running, 1 = Stopped with PCI_STP#
4	0	SRC4	Allow control of SRC[T/C]4 with assertion of PCI_STP# or SW PCI_STP# 0 = Free running, 1 = Stopped with PCI_STP#

**Byte 4 Control Register 4 (continued)**

Bit	@Pup	Name	Description
3	0	SRC3	Allow control of SRC[T/C]3 with assertion of PCI_STP# or SW PCI_STP# 0 = Free running, 1 = Stopped with PCI_STP#
2	0	SRC2	Allow control of SRC[T/C]2 with assertion of PCI_STP# or SW PCI_STP# 0 = Free running, 1 = Stopped with PCI_STP#
1	0	SRC1	Allow control of SRC[T/C]1 with assertion of PCI_STP# or SW PCI_STP# 0 = Free running, 1 = Stopped with PCI_STP#
0	0	SRC0	Allow control of SRC[T/C]0 with assertion of PCI_STP# or SW PCI_STP# 0 = Free running, 1 = Stopped with PCI_STP#

**Byte 5 Control Register 5**

Bit	@Pup	Name	Description
7	0	LCD_96_100M[T/C]	LCD_96_100M[T/C] PWRDWN Drive Mode 0 = Driven in PWRDWN, 1 = Tri-state
6	0	DOT96[T/C]	DOT PWRDWN Drive Mode 0 = Driven in PWRDWN, 1 = Tri-state
5	0	RESERVED	RESERVED, Set = 0
4	0	RESERVED	RESERVED, Set = 0
3	0	PCIF0	Allow control of PCIF0 with assertion of SW and HW PCI_STP# 0 = Free running, 1 = Stopped with PCI_STP#
2	1	CPU[T/C]2	Allow control of CPU[T/C]2 with assertion of CPU_STP# 0 = Free running, 1 = Stopped with CPU_STP#
1	1	CPU[T/C]1	Allow control of CPU[T/C]1 with assertion of CPU_STP# 0 = Free running, 1 = Stopped with CPU_STP#
0	1	CPU[T/C]0	Allow control of CPU[T/C]0 with assertion of CPU_STP# 0 = Free running, 1 = Stopped with CPU_STP#

**Byte 6 Control Register 6**

Bit	@Pup	Name	Description
7	0	SRC[T/C]	SRC[T/C] Stop Drive Mode 0 = Driven when PCI_STP# asserted 1 = Tri-state when PCI_STP# asserted
6	0	CPU[T/C]2	CPU[T/C]2 Stop Drive Mode 0 = Driven when CPU_STP# asserted 1 = Tri-state when CPU_STP# asserted
5	0	CPU[T/C]1	CPU[T/C]1 Stop Drive Mode 0 = Driven when CPU_STP# asserted 1 = Tri-state when CPU_STP# asserted
4	0	CPU[T/C]0	CPU[T/C]0 Stop Drive Mode 0 = Driven when CPU_STP# asserted 1 = Tri-state when CPU_STP# asserted
3	0	SRC[T/C][9:1]	SRC[T/C][9:1] PWRDWN Drive Mode 0 = Driven when PD asserted 1 = Tri-state when PD asserted
2	0	CPU[T/C]2	CPU[T/C]2 PWRDWN Drive Mode 0 = Driven when PD asserted 1 = Tri-state when PD asserted
1	0	CPU[T/C]1	CPU[T/C]1 PWRDWN Drive Mode 0 = Driven when PD asserted 1 = Tri-state when PD asserted
0	0	CPU[T/C]0	CPU[T/C]0 PWRDWN Drive Mode 0 = Driven when PD asserted 1 = Tri-state when PD asserted

**Byte 7 Control Register 7**

Bit	@Pup	Name	Description
7	0	TEST_SEL	REF/N or Tri-state Select 0 = Tri-state, 1 = REF/N Clock
6	0	TEST_MODE	Test Clock Mode Entry Control 0 = Normal operation, 1 = REF/N or Tri-state mode,
5	1	REF1	REF1 Output Drive Strength 0 = Low, 1 = High
4	1	REF0	REF0 Output Drive Strength 0 = Low, 1 = High
3	1	PCI, PCIF and SRC clock outputs except those set to free running	SW PCI_STP Function 0 = SW PCI_STP assert, 1= SW PCI_STP deassert When this bit is set to 0, all STOPPABLE PCI, PCIF and SRC outputs will be stopped in a synchronous manner with no short pulses. When this bit is set to 1, all STOPPED PCI, PCIF and SRC outputs will resume in a synchronous manner with no short pulses.
2	HW	FSC	FSC Reflects the value of the FSC pin sampled on power up 0 = FSC was low during VTT_PWRGD# assertion
1	HW	FSB	FSB Reflects the value of the FSB pin sampled on power up 0 = FSB was low during VTT_PWRGD# assertion
0	HW	FSA	FSA Reflects the value of the FSA pin sampled on power up 0 = FSA was low during VTT_PWRGD# assertion

**Byte 8 Vendor ID**

Bit	@Pup	Name	Description
7	0	Revision Code Bit 3	Revision Code Bit 3
6	0	Revision Code Bit 2	Revision Code Bit 2
5	1	Revision Code Bit 1	Revision Code Bit 1
4	1	Revision Code Bit 0	Revision Code Bit 0
3	1	Vendor ID Bit 3	Vendor ID Bit 3
2	0	Vendor ID Bit 2	Vendor ID Bit 2
1	0	Vendor ID Bit 1	Vendor ID Bit 1
0	0	Vendor ID Bit 0	Vendor ID Bit 0

**Byte 9 Control Register 9**

Bit	@Pup	Name	Description
7	0	RESERVED	RESERVED, Set = 0
6	0	RESERVED	RESERVED, Set = 0
5	0	RESERVED	RESERVED
4	0	RESERVED	RESERVED
3	0	RESERVED	RESERVED
2	1	48M	48-MHz Output Drive Strength 0 = Low, 1 = High
1	1	RESERVED	RESERVED
0	1	PCIF0	PCIF0 Output Drive Strength 0 = Low, 1 = High

**Byte 10 Control Register 10**

Bit	@Pup	Name	Description
7	0	RESERVED	RESERVED
6	0	RESERVED	RESERVED

**Byte 10 Control Register 10** (continued)

Bit	@Pup	Name	Description
5	0	S1	27M_SS/LCD 96_100M SS Spread Spectrum Selection table: S[1:0] SS% '00' = -0.5%(Default value) '01' = -1.0% '10' = -1.5% '11' = -2.0%
4	0	S0	
3	1	RESERVED	RESERVED
2	1	27M_SS	27M Spread Output Enable 0 = Disabled, 1 = Enabled
1	1	27M_SS/LCD_100M Spread Enable	27M_SS/LCD_100M Spread spectrum enable. 0 = Disabled, 1 = Enabled
0	0	RESERVED	RESERVED

**Byte 11 Control Register 11**

Bit	@Pup	Name	Description
7	0	RESERVED	RESERVED
6	0	RESERVED	RESERVED
5	1	SRC[T/C]9	SRC[T/C]9 Output Enable 0 = Disable (Hi-Z), 1 = Enable
4	1	SRC[T/C]8	SRC[T/C]8 Output Enable 0 = Disable (Hi-Z), 1 = Enable
3	1	RESERVED	RESERVED
2	0	SRC[T/C]10	Allow control of SRC[T/C]10 with assertion of SW PCI_STP# 0 = Free running, 1 = Stopped with PCI_STP#
1	0	SRC[T/C]9	Allow control of SRC[T/C]9 with assertion of SW PCI_STP# 0 = Free running, 1 = Stopped with PCI_STP#
0	0	SRC[T/C]8	Allow control of SRC[T/C]8 with assertion of SW PCI_STP# 0 = Free running, 1 = Stopped with PCI_STP#

**Byte 12 Control Register 12**

Bit	@Pup	Name	Description
7	0	RESERVED	RESERVED, Set = 0
6	HW	RESERVED	RESERVED
5	HW	RESERVED	RESERVED
4	HW	RESERVED	RESERVED
3	0	27M_SS/27M_NSS	27-MHz (spread and non-spread) Output Drive Strength 0 = Low, 1 = High
2	0	RESERVED	RESERVED
1	1	RESERVED	RESERVED, Set = 1
0	HW	RESERVED	RESERVED

**Byte 13 Control Register 13**

Bit	@Pup	Name	Description
7	0	CLKREQ#9	CLKREQ#9 Input Enable 0 = Disabled, 1 = Enabled
6	0	CLKREQ#8	CLKREQ#8 Input Enable 0 = Disabled, 1 = Enabled
5	0	CLKREQ#7	CLKREQ#7 Input Enable 0 = Disabled, 1 = Enabled

**Byte 13 Control Register 13** (continued)

Bit	@Pup	Name	Description
4	0	CLKREQ#6	CLKREQ#6 Input Enable 0 = Disabled, 1 = Enabled
3	0	CLKREQ#5	CLKREQ#5 Input Enable 0 = Disabled, 1 = Enabled
2	0	CLKREQ#4	CLKREQ#4 Input Enable 0 = Disabled, 1 = Enabled
1	0	CLKREQ#3	CLKREQ#3 Input Enable 0 = Disabled, 1 = Enabled
0	0	CLKREQ#2	CLKREQ#2 Input Enable 0 = Disabled, 1 = Enabled

**Byte 14 Control Register 14**

Bit	@Pup	Name	Description
7	0	CLKREQ#1	CLKREQ#1 Input Enable 0 = Disabled, 1 = Enabled
6	1	LCD 96_100M Clock Speed	LCD 96_100M Clock Speed 0 = 96 MHz 1 = 100 MHz
5	1	RESERVED	RESERVED, Set = 1
4	1	RESERVED	RESERVED, Set = 1
3	1	PCI4	PCI4 (Spread and Non-spread) Output Drive Strength 0 = Low, 1 = High
2	1	PCI3	PCI3 (Spread and Non-spread) Output Drive Strength 0 = Low, 1 = High
1	1	PCI2	PCI2 (Spread and Non-spread) Output Drive Strength 0 = Low, 1 = High
0	1	PCI1	PCI1 (Spread and Non-spread) Output Drive Strength 0 = Low, 1 = High

**Byte 15 Control Register 15**

Bit	@Pup	Name	Description
7	HW	TME_STRAP	Trusted mode enable strap status, 0 = Normal 1 = No overclocking (default)
6	1	RESERVED	RESERVED
5	1	RESERVED	RESERVED
4	1	RESERVED	RESERVED
3	1	RESERVED	RESERVED
2	0	IO_VOUT2	IO_VOUT[2,1,0]
1	1	IO_VOUT1	000 = 0.63V
0	1	IO_VOUT0	001 = 0.71V 010 = 0.77V 011 = 0.82V (Default) 100 = 0.86V 101 = 0.90V 110 = 0.93V 111 = Reserved

**Table 6. Crystal Recommendations**

Frequency (Fund)	Cut	Loading	Load Cap	Drive (max.)	Shunt Cap (max.)	Motional (max.)	Tolerance (max.)	Stability (max.)	Aging (max.)
14.31818 MHz	AT	Parallel	20 pF	0.1 mW	5 pF	0.016 pF	35 ppm	30 ppm	5 ppm

The CY28547 requires a Parallel Resonance Crystal. Substituting a series resonance crystal will cause the CY28547 to

operate at the wrong frequency and violate the ppm specification. For most applications there is a 300-ppm frequency

shift between series and parallel crystals due to incorrect loading.

### Crystal Loading

Crystal loading plays a critical role in achieving low ppm performance. To realize low ppm performance, the total capacitance the crystal will see must be considered to calculate the appropriate capacitive loading (CL).

Figure 1 shows a typical crystal configuration using the two trim capacitors. An important clarification for the following discussion is that the trim capacitors are in series with the crystal not parallel. It's a common misconception that load capacitors are in parallel with the crystal and should be approximately equal to the load capacitance of the crystal. This is not true.

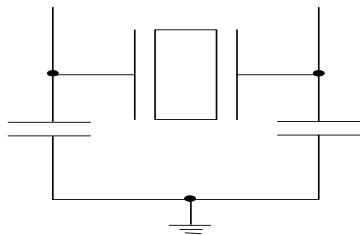


Figure 1. Crystal Capacitive Clarification

### Calculating Load Capacitors

In addition to the standard external trim capacitors, trace capacitance and pin capacitance must also be considered to correctly calculate crystal loading. As mentioned previously, the capacitance on each side of the crystal is in series with the crystal. This means the total capacitance on each side of the crystal must be twice the specified crystal load capacitance (CL). While the capacitance on each side of the crystal is in series with the crystal, trim capacitors (Ce1,Ce2) should be calculated to provide equal capacitive loading on both sides.

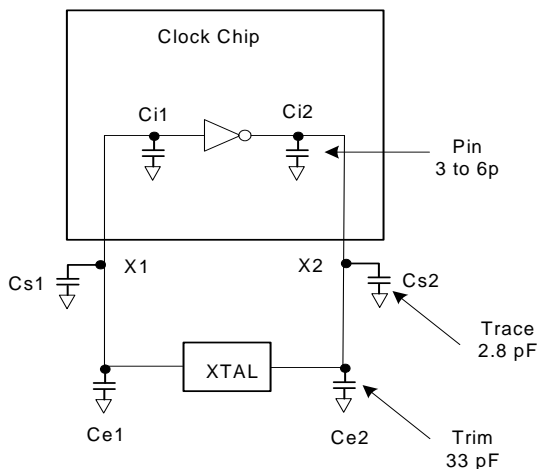


Figure 2. Crystal Loading Example

Use the following formulas to calculate the trim capacitor values for Ce1 and Ce2.

#### Load Capacitance (each side)

$$C_e = 2 * CL - (C_s + C_i)$$

#### Total Capacitance (as seen by the crystal)

$$CL_e = \frac{1}{\left( \frac{1}{C_{e1} + C_{s1} + C_{i1}} + \frac{1}{C_{e2} + C_{s2} + C_{i2}} \right)}$$

CL.....Crystal load capacitance

CL<sub>e</sub>..... Actual loading seen by crystal using standard value trim capacitors

C<sub>e</sub>..... External trim capacitors

C<sub>s</sub>..... Stray capacitance (terraced)

C<sub>i</sub> ..... Internal capacitance (lead frame, bond wires etc.)

### CLK\_REQ# Description

The CLKREQ# signals are active LOW inputs used for clean enabling and disabling selected SRC outputs. The outputs controlled by CLKREQ# are determined by the settings in register byte 8. The CLKREQ# signal is a de-bounced signal in that its state must remain unchanged during two consecutive rising edges of SRCC to be recognized as a valid assertion or deassertion. (The assertion and deassertion of this signal is absolutely asynchronous.)

#### CLK\_REQ[1:9]# Assertion (CLKREQ# -> LOW)

All differential outputs that were stopped are to resume normal operation in a glitch-free manner. The maximum latency from the assertion to active outputs is between 2 and 6 SRC clock periods (2 clocks are shown) with all SRC outputs resuming simultaneously. All stopped SRC outputs must be driven HIGH within 10 ns of CLKREQ# deassertion to a voltage greater than 200 mV.

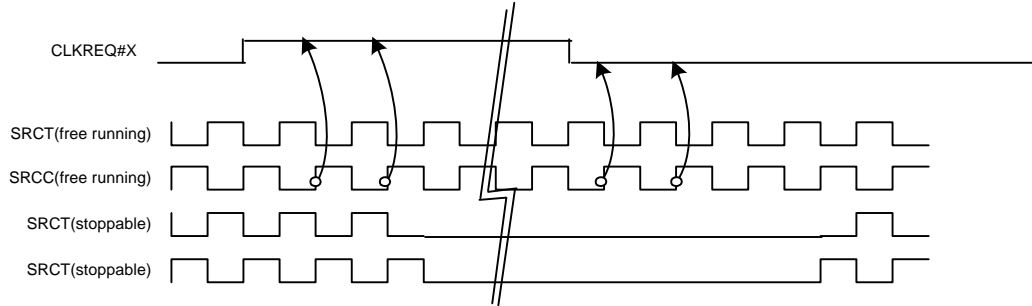


Figure 3. CLK\_REQ#[1:9] Deassertion/Assertion Waveform

**CLK\_REQ[1:9]# Deassertion (CLKREQ# -> HIGH)**

The impact of deasserting the CLKREQ# pins is that all SRC outputs that are set in the control registers to stoppable via deassertion of CLKREQ# are to be stopped after their next transition. The final state of all stopped SRC clocks is Low/Low.

**PD (Power-down) Clarification**

The VTT\_PWRGD#/PD pin is a dual-function pin. During initial power-up, the pin functions as VTT\_PWRGD#. Once VTT\_PWRGD# has been sampled LOW by the clock chip, the pin assumes PD functionality. The PD pin is an asynchronous active HIGH input used to shut off all clocks cleanly prior to shutting off power to the device. This signal is synchronized internal to the device prior to powering down the clock synthesizer. PD is also an asynchronous input for powering up the system. When PD is asserted HIGH, all clocks need to be driven to a LOW value and held prior to turning off the VCOs and the crystal oscillator.

**PD (Power-down) Assertion**

When PD is sampled HIGH by two consecutive rising edges of CPUC, all single-ended outputs will be held LOW on their next HIGH-to-LOW transition and differential clocks must be held HIGH or tri-stated (depending on the state of the control register drive mode bit) on the next diff clock# HIGH-to-LOW transition within 4 clock periods. When the SMBus PD drive mode bit corresponding to the differential (CPU, SRC, and

DOT) clock output of interest is programmed to '0', the clock outputs are held with "Diff clock" pin driven HIGH, and "Diff clock#" tri-state. If the control register PD drive mode bit corresponding to the output of interest is programmed to "1", then both the "Diff clock" and the "Diff clock#" are tri-state. Note that Figure 4 shows CPUC = 133 MHz and PD drive mode = '1' for all differential outputs. This diagram and description is applicable to valid CPU frequencies 100, 133, 166, and 200 MHz. In the event that PD mode is desired as the initial power-on state, PD must be asserted HIGH in less than 10 μs after asserting Vtt\_PwrGd#. It should be noted that 96\_100\_SSC will follow the DOT waveform when selected for 96 MHz and the SRC waveform when in 100-MHz mode.

**PD Deassertion**

The power-up latency is less than 1.8 ms. This is the time from the deassertion of the PD pin or the ramping of the power supply until the time that stable clocks are output from the clock chip. All differential outputs stopped in a three-state condition resulting from power down will be driven high in less than 300 μs of PD deassertion to a voltage greater than 200 mV. After the clock chip's internal PLL is powered up and locked, all outputs will be enabled within a few clock cycles of each other. Figure 5 is an example showing the relationship of clocks coming up. It should be noted that 96\_100\_SSC will follow the DOT waveform when selected for 96 MHz and the SRC waveform when in 100-MHz mode.

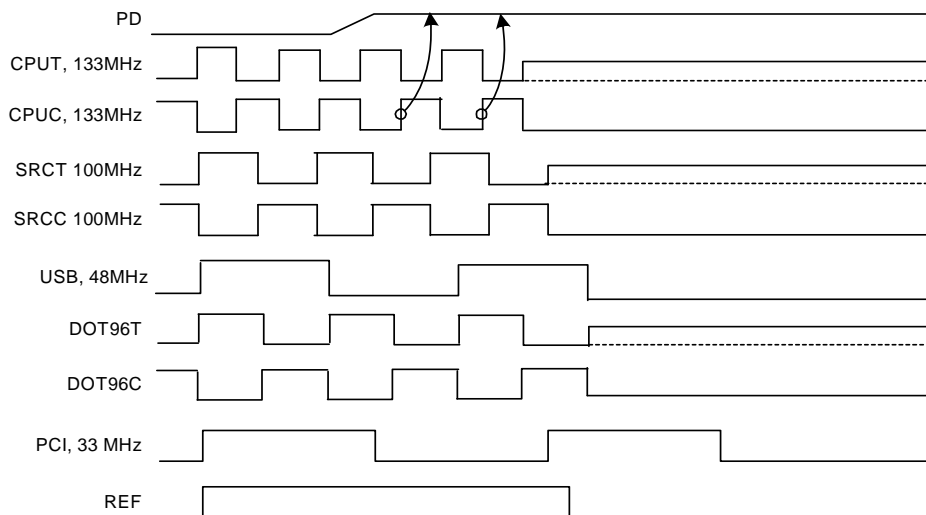
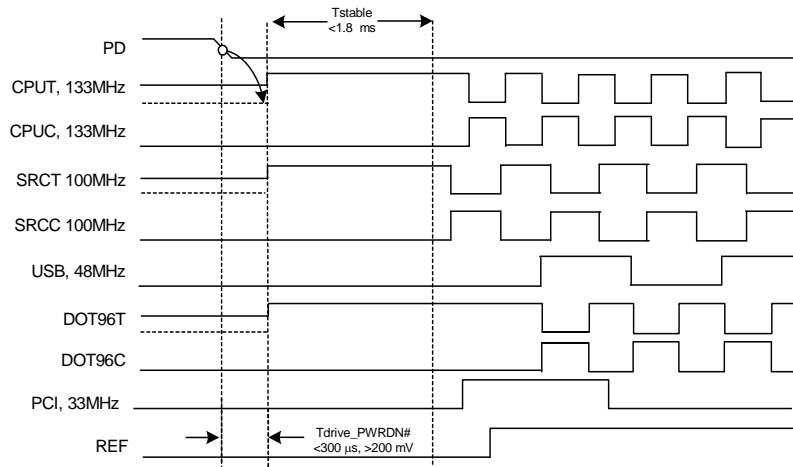


Figure 4. Power-down Assertion Timing Waveform

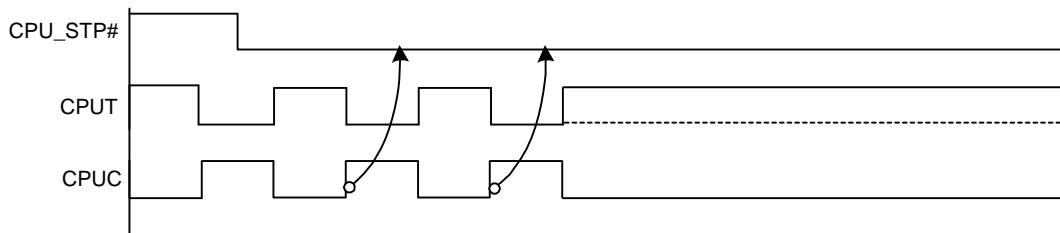


**Figure 5. Power-down Deassertion Timing Waveform**

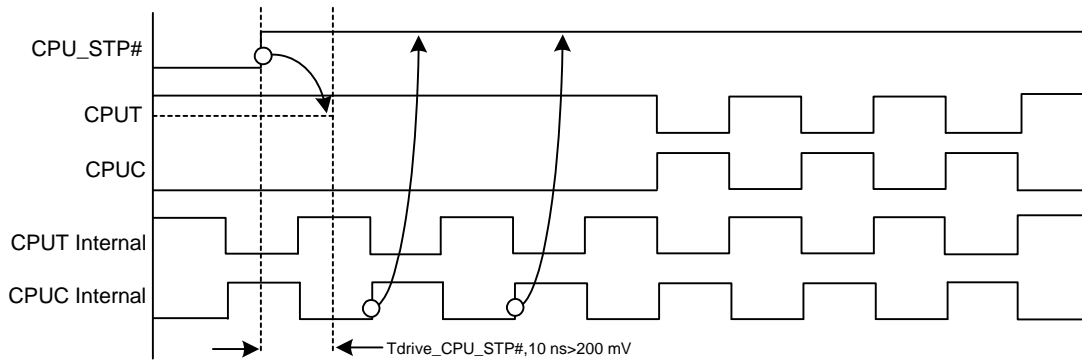
**CPU\_STP# Assertion**

The CPU\_STP# signal is an active LOW input used for synchronous stopping and starting the CPU output clocks while the rest of the clock generator continues to function. When the CPU\_STP# pin is asserted, all CPU outputs that are

set with the SMBus configuration to be stoppable via assertion of CPU\_STP# will be stopped within two–six CPU clock periods after being sampled by two rising edges of the internal CPUC clock. The final state of all stopped CPU clocks is High/Low when driven, Low/Low when tri-stated.



**Figure 6. CPU\_STP# Assertion Waveform**



**Figure 7. CPU\_STP# Deassertion Waveform**

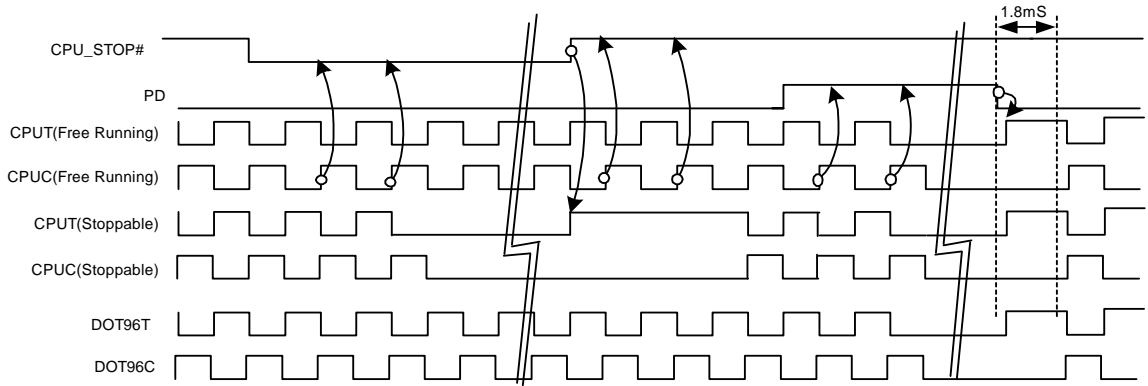
**PCI\_STP# Assertion**

The PCI\_STP# signal is an active LOW input used for synchronous stopping and starting the PCI outputs and SRC outputs if they are set to be stoppable in SMBus while the rest of the clock generator continues to function. The set-up time for capturing PCI\_STP# going LOW is 10 ns ( $t_{SU}$ ). (See Figure 9.) The PCIF clocks will not be affected by this pin if their corresponding control bit in the SMBus register is set to allow them to be free running. All stopped PCI outputs are

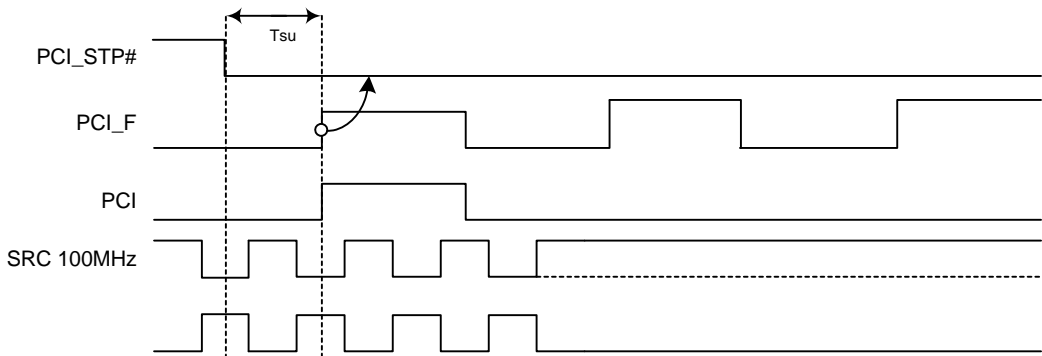
driven Low, SRC outputs are High/Low if set to driven and Low/Low if set to tri-state.

**PCI\_STP# Deassertion**

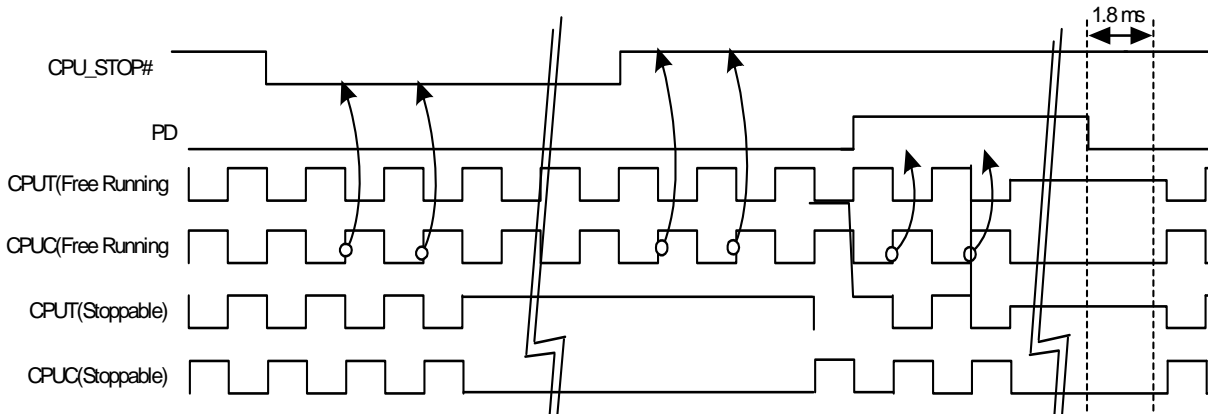
The deassertion of the PCI\_STP# signal will cause all PCI and stoppable PCIF clocks to resume running in a synchronous manner within two PCI clock periods after PCI\_STP# transitions to a HIGH level



**Figure 8. CPU\_STP# = Tri-state, CPU\_PD = Tri-state, DOT\_PD = Tri-state**



**Figure 9. PCI\_STP# Assertion Waveform**



**Figure 10. CPU\_STP# = Driven, CPU\_PD = Driven, DOT\_PD = Driven**

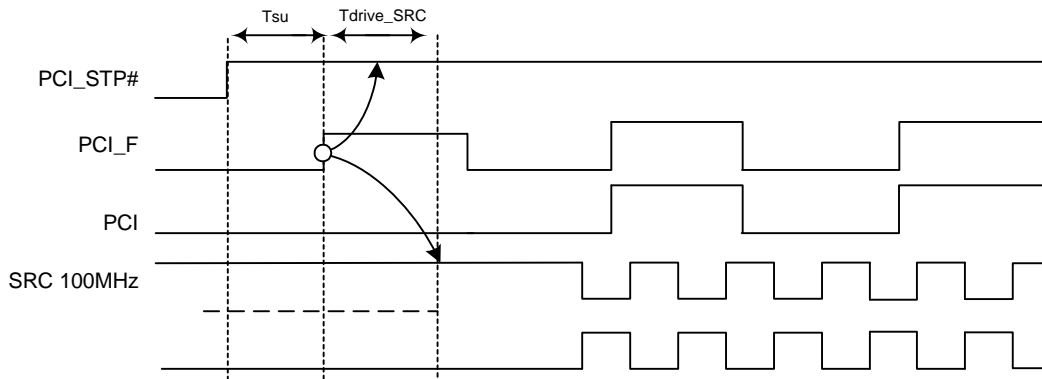


Figure 11. PCI\_STP# Deassertion Waveform

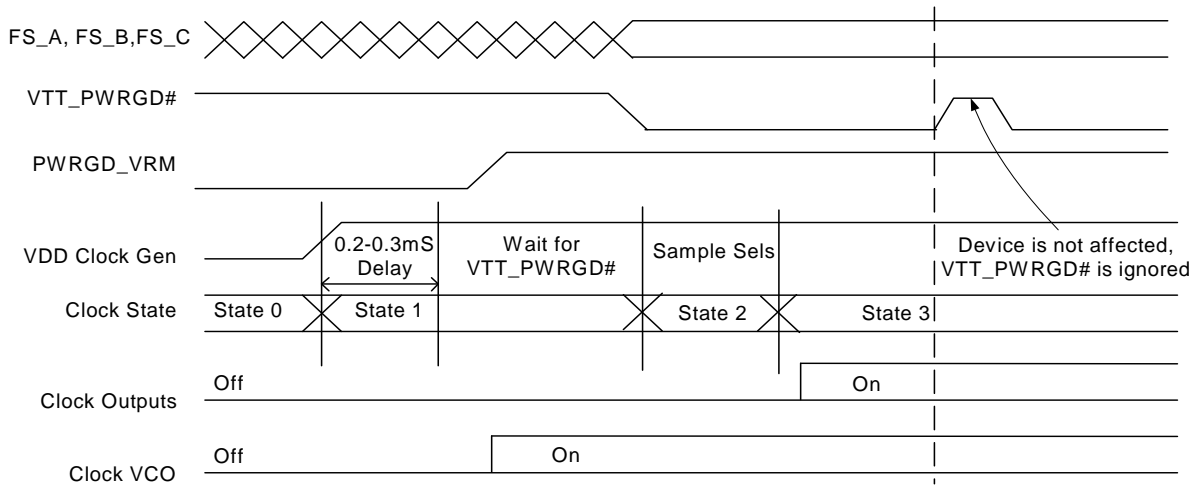


Figure 12. VTPWRGD# Timing Diagram

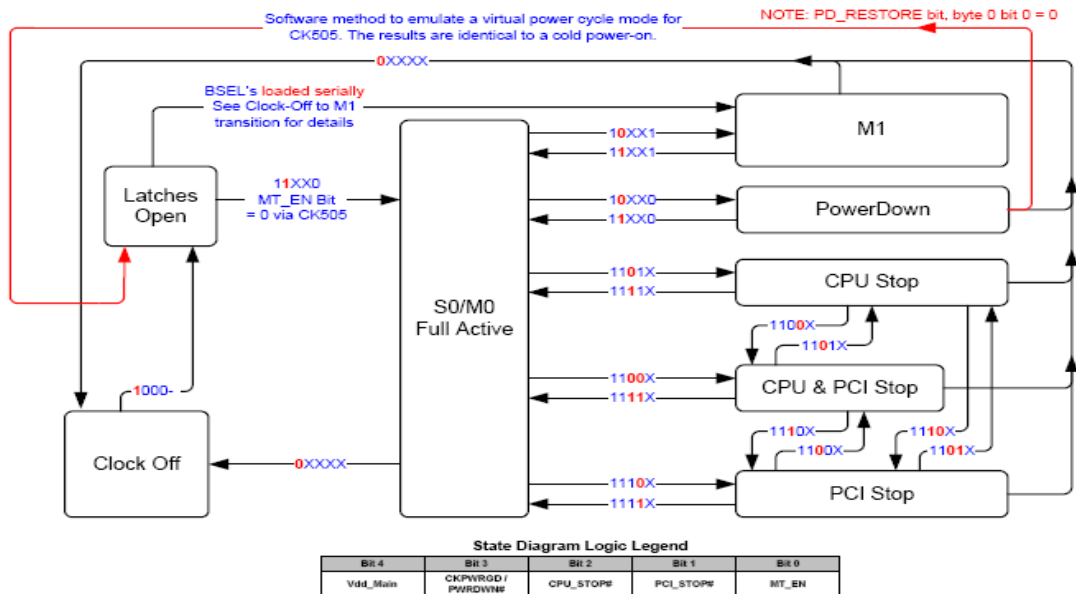


Figure 13. CY28547 State Diagram

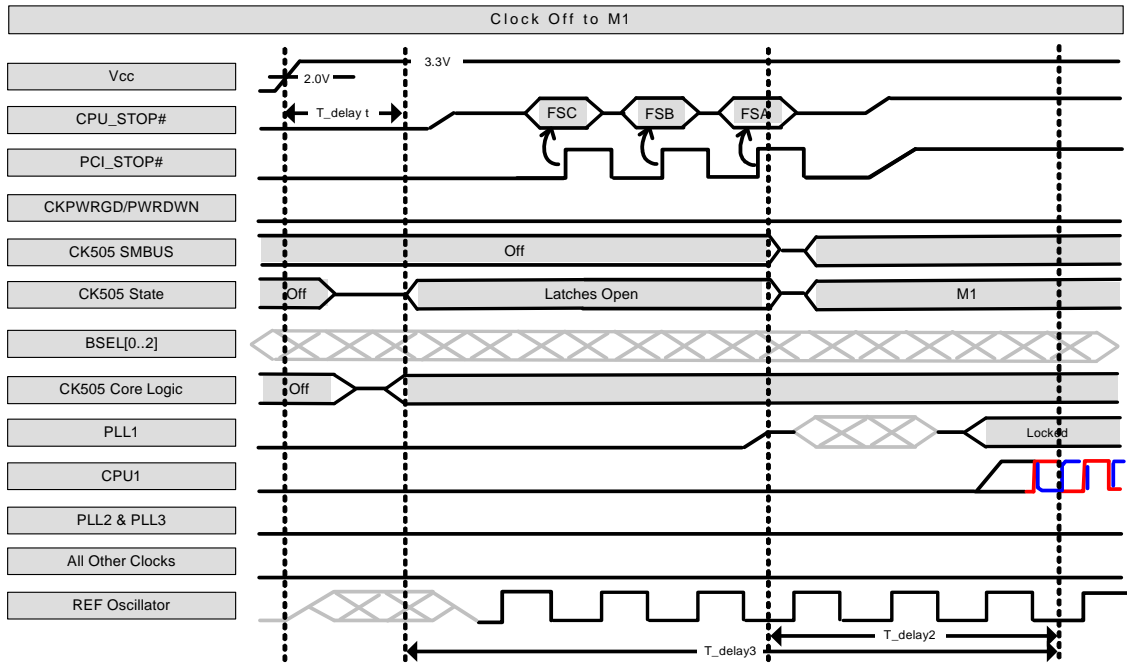


Figure 14. BSEL Serial Latching

**Absolute Maximum Conditions**

Parameter	Description	Condition	Min.	Max.	Unit
V <sub>DD</sub>	Core Supply Voltage		-0.5	4.6	V
V <sub>DD_A</sub>	Analog Supply Voltage		-0.5	4.6	V
V <sub>IN</sub>	Input Voltage	Relative to V <sub>SS</sub>	-0.5	V <sub>DD</sub> + 0.5	VDC
T <sub>S</sub>	Temperature, Storage	Non-functional	-65	150	°C
T <sub>A</sub>	Temperature, Operating Ambient	Functional	0	85	°C
T <sub>J</sub>	Temperature, Junction	Functional	-	150	°C
∅ <sub>JC</sub>	Dissipation, Junction to Case	Mil-STD-883E Method 1012.1	-	20	°C/W
∅ <sub>JA</sub>	Dissipation, Junction to Ambient	JEDEC (JESD 51)	-	60	°C/W
ESD <sub>HBM</sub>	ESD Protection (Human Body Model)	MIL-STD-883, Method 3015	2000	-	V
UL-94	Flammability Rating	At 1/8 in.	V-0		
MSL	Moisture Sensitivity Level		1		

**Multiple Supplies:** The Voltage on any input or I/O pin cannot exceed the power pin during power-up. Power supply sequencing is NOT required.

**DC Electrical Specifications**

Parameter	Description	Condition	Min.	Max.	Unit
All VDDs	3.3V Operating Voltage	3.3 ± 5%	3.135	3.465	V
V <sub>IL12C</sub>	Input Low Voltage	SDATA, SCLK	-	1.0	V
V <sub>IH12C</sub>	Input High Voltage	SDATA, SCLK	2.2	-	V
V <sub>IL_FS</sub>	FS_[A,B] Input Low Voltage		V <sub>SS</sub> - 0.3	0.35	V
V <sub>IH_FS</sub>	FS_[A,B] Input High Voltage		0.7	V <sub>DD</sub> + 0.5	V
V <sub>ILFS_C</sub>	FS_C Input Low Voltage		V <sub>SS</sub> - 0.3	0.35	V
V <sub>IMFS_C</sub>	FS_C Input Middle Voltage		0.7	1.7	V
V <sub>IHFS_C</sub>	FS_C Input High Voltage		2.0	V <sub>DD</sub> + 0.5	V
V <sub>IL</sub>	3.3V Input Low Voltage		V <sub>SS</sub> - 0.3	0.8	V
V <sub>IH</sub>	3.3V Input High Voltage		2.0	V <sub>DD</sub> + 0.3	V
I <sub>IL</sub>	Input Low Leakage Current	Except internal pull-up resistors, 0 < V <sub>IN</sub> < V <sub>DD</sub>	-5	5	μA
I <sub>IH</sub>	Input High Leakage Current	Except internal pull-down resistors, 0 < V <sub>IN</sub> < V <sub>DD</sub>	-	5	μA
V <sub>OL</sub>	3.3V Output Low Voltage	I <sub>OL</sub> = 1 mA	-	0.4	V
V <sub>OH</sub>	3.3V Output High Voltage	I <sub>OH</sub> = -1 mA	2.4	-	V
I <sub>OZ</sub>	High-impedance Output Current		-10	10	μA
C <sub>IN</sub>	Input Pin Capacitance		3	5	pF
C <sub>OUT</sub>	Output Pin Capacitance		3	6	pF
L <sub>IN</sub>	Pin Inductance		-	7	nH
V <sub>XIH</sub>	Xin High Voltage		0.7V <sub>DD</sub>	V <sub>DD</sub>	V
V <sub>XIL</sub>	Xin Low Voltage		0	0.3V <sub>DD</sub>	V
I <sub>DD3.3V</sub>	Dynamic Supply Current	In low drive mode per <i>Figure 15</i> and <i>Figure 17</i> @ 133 MHz	-	250	mA
I <sub>PD3.3V</sub>	Power-down Supply Current	PD asserted, Outputs Driven	-	30	mA
I <sub>PD3.3V</sub>	Power-down Supply Current	PD asserted, Outputs Tri-state	-	5	mA

**AC Electrical Specifications**

Parameter	Description	Condition	Min.	Max.	Unit
<b>Crystal</b>					
T <sub>DC</sub>	XIN Duty Cycle	The device will operate reliably with input duty cycles up to 30/70 but the REF clock duty cycle will not be within specification	47.5	52.5	%
T <sub>PERIOD</sub>	XIN Period	When XIN is driven from an external clock source	69.841	71.0	ns
T <sub>R</sub> /T <sub>F</sub>	XIN Rise and Fall Times	Measured between 0.3V <sub>DD</sub> and 0.7V <sub>DD</sub>	–	10.0	ns
T <sub>CCJ</sub>	XIN Cycle to Cycle Jitter	As an average over 1-μs duration	–	500	ps
<b>CPU</b>					
T <sub>DC</sub>	CPUT and CPUC Duty Cycle	Measured at 0V differential at 0.1s	45	55	%
T <sub>PERIOD</sub>	100 MHz CPUT and CPUC Period	Measured at 0V differential at 0.1s	9.99900	10.0100	ns
T <sub>PERIOD</sub>	133 MHz CPUT and CPUC Period	Measured at 0V differential at 0.1s	7.49925	7.50075	ns
T <sub>PERIOD</sub>	166 MHz CPUT and CPUC Period	Measured at 0V differential at 0.1s	5.99940	6.00060	ns
T <sub>PERIOD</sub>	200 MHz CPUT and CPUC Period	Measured at 0V differential at 0.1s	4.99950	5.00050	ns
T <sub>PERIOD</sub>	266 MHz CPUT and CPUC Period	Measured at 0V differential at 0.1s	3.74963	3.75038	ns
T <sub>PERIOD</sub>	333 MHz CPUT and CPUC Period	Measured at 0V differential at 0.1s	2.99970	3.00030	ns
T <sub>PERIOD</sub>	400 MHz CPUT and CPUC Period	Measured at 0V differential at 0.1s	2.49975	2.50025	ns
T <sub>PERIODSS</sub>	100 MHz CPUT and CPUC Period, SSC	Measured at 0V differential at 0.1s	10.02406	10.02607	ns
T <sub>PERIODSS</sub>	133 MHz CPUT and CPUC Period, SSC	Measured at 0V differential at 0.1s	7.51804	7.51955	ns
T <sub>PERIODSS</sub>	166 MHz CPUT and CPUC Period, SSC	Measured at 0V differential at 0.1s	6.01444	6.01564	ns
T <sub>PERIODSS</sub>	200 MHz CPUT and CPUC Period, SSC	Measured at 0V differential at 0.1s	5.01203	5.01303	ns
T <sub>PERIODSS</sub>	266 MHz CPUT and CPUC Period, SSC	Measured at 0V differential at 0.1s	3.75902	3.75978	ns
T <sub>PERIODSS</sub>	333 MHz CPUT and CPUC Period, SSC	Measured at 0V differential at 0.1s	3.00722	3.00782	ns
T <sub>PERIODSS</sub>	400 MHz CPUT and CPUC Period, SSC	Measured at 0V differential at 0.1s	2.50601	2.50652	ns
T <sub>PERIODAbs</sub>	100 MHz CPUT and CPUC Absolute period	Measured at 0V differential at 1 clock	9.91400	10.0860	ns
T <sub>PERIODAbs</sub>	133 MHz CPUT and CPUC Absolute period	Measured at 0V differential at 1 clock	7.41425	7.58575	ns
T <sub>PERIODAbs</sub>	166 MHz CPUT and CPUC Absolute period	Measured at 0V differential @ 1 clock	5.91440	6.08560	ns
T <sub>PERIODAbs</sub>	200 MHz CPUT and CPUC Absolute period	Measured at 0V differential @ 1 clock	4.91450	5.08550	ns
T <sub>PERIODAbs</sub>	266 MHz CPUT and CPUC Absolute period	Measured at 0V differential @ 1 clock	3.66463	3.83538	ns
T <sub>PERIODAbs</sub>	333 MHz CPUT and CPUC Absolute period	Measured at 0V differential @ 1 clock	2.91470	3.08530	ns
T <sub>PERIODAbs</sub>	400 MHz CPUT and CPUC Absolute period	Measured at 0V differential @ 1 clock	2.41475	2.58525	ns
T <sub>PERIODSSAbs</sub>	100 MHz CPUT and CPUC Absolute period, SSC	Measured at 0V differential @ 1 clock	9.91406	10.1362	ns
T <sub>PERIODSSAbs</sub>	133 MHz CPUT and CPUC Absolute period, SSC	Measured at 0V differential @ 1 clock	7.41430	7.62340	ns

**AC Electrical Specifications** (continued)

Parameter	Description	Condition	Min.	Max.	Unit
T <sub>PERI-ODSSAbs</sub>	166 MHz CPUT and CPUC Absolute period, SSC	Measured at 0V differential @ 1 clock	5.91444	6.11572	ns
T <sub>PERI-ODSSAbs</sub>	200 MHz CPUT and CPUC Absolute period, SSC	Measured at 0V differential @ 1 clock	4.91453	5.11060	ns
T <sub>PERI-ODSSAbs</sub>	266 MHz CPUT and CPUC Absolute period, SSC	Measured at 0V differential @ 1 clock	3.66465	3.85420	ns
T <sub>PERI-ODSSAbs</sub>	333 MHz CPUT and CPUC Absolute period, SSC	Measured at 0V differential @ 1 clock	2.91472	3.10036	ns
T <sub>PERI-ODSSAbs</sub>	400 MHz CPUT and CPUC Absolute period, SSC	Measured at 0V differential @ 1 clock	2.41477	2.59780	ns
T <sub>CCJ</sub>	CPU Cycle to Cycle Jitter	Measured at 0V differential	–	85	ps
T <sub>CCJ2</sub>	CPU2_ITP Cycle to Cycle Jitter	Measured at 0V differential	–	125	ps
L <sub>ACC</sub>	Long-term Accuracy	Measured at 0V differential	–	100	ppm
T <sub>SKEW</sub>	CPU0 to CPU1 Clock Skew	Measured at 0V differential	–	100	ps
T <sub>SKEW2</sub>	CPU2_ITP to CPU0 Clock Skew	Measured at 0V differential	–	150	ps
T <sub>R</sub> / T <sub>F</sub>	CPU Rising/Falling Slew rate	Measured differentially from ±150 mV	2.5	8	V/ns
T <sub>RFM</sub>	Rise/Fall Matching	Measured single-endedly from ±75 mV	–	20	%
V <sub>HIGH</sub>	Voltage High			1.15	V
V <sub>LOW</sub>	Voltage Low		–0.3	–	V
V <sub>OX</sub>	Crossing Point Voltage at 0.7V Swing		300	550	mV
<b>SRC at 0.7V</b>					
T <sub>DC</sub>	SRC Duty Cycle	Measured at 0V differential	45	55	%
T <sub>PERIOD</sub>	100 MHz SRC Period	Measured at 0V differential @ 0.1s	9.99900	10.0010	ns
T <sub>PERIODSS</sub>	100 MHz SRC Period, SSC	Measured at 0V differential @ 0.1s	10.02406	10.02607	ns
T <sub>PERIODAbs</sub>	100 MHz SRC Absolute Period	Measured at 0V differential @ 1 clock	9.87400	10.1260	ns
T <sub>PERI-ODSSAbs</sub>	100 MHz SRC Absolute Period, SSC	Measured at 0V differential @ 1 clock	9.87406	10.1762	ns
T <sub>SKEW(window)</sub>	Any SRC Clock Skew from the earliest bank to the latest bank	Measured at 0V differential	–	3.0	ns
T <sub>CCJ</sub>	SRC Cycle to Cycle Jitter	Measured at 0V differential	–	125	ps
L <sub>ACC</sub>	SRC Long Term Accuracy	Measured at 0V differential	–	100	ppm
T <sub>R</sub> / T <sub>F</sub>	SRC Rising/Falling Slew Rate	Measured differentially from ±150 mV	2.5	8	V/ns
T <sub>RFM</sub>	Rise/Fall Matching	Measured single-endedly from ±75 mV	–	20	%
V <sub>HIGH</sub>	Voltage High			1.15	V
V <sub>LOW</sub>	Voltage Low		–0.3	–	V
V <sub>OX</sub>	Crossing Point Voltage at 0.7V Swing		300	550	mV
<b>DOT96 at 0.7V</b>					
T <sub>DC</sub>	DOT96 Duty Cycle	Measured at 0V differential	45	55	%
T <sub>PERIOD</sub>	DOT96 Period	Measured at 0V differential at 0.1s	10.4156	10.4177	ns
T <sub>PERIODAbs</sub>	DOT96 Absolute Period	Measured at 0V differential at 0.1s	10.1656	10.6677	ns
T <sub>CCJ</sub>	DOT96 Cycle to Cycle Jitter	Measured at 0V differential at 1 clock	–	250	ps
L <sub>ACC</sub>	DOT96 Long Term Accuracy	Measured at 0V differential at 1 clock	–	100	ppm
T <sub>R</sub> / T <sub>F</sub>	DOT96 Rising/Falling Slew Rate	Measured differentially from ±150 mV	2.5	8	V/ns
T <sub>RFM</sub>	Rise/Fall Matching	Measured single-endedly from ±75 mV	–	20	%
V <sub>HIGH</sub>	Voltage High			1.15	V

**AC Electrical Specifications** (continued)

Parameter	Description	Condition	Min.	Max.	Unit
V <sub>LOW</sub>	Voltage Low		-0.3	-	V
V <sub>OX</sub>	Crossing Point Voltage at 0.7V Swing		300	550	mV
<b>LCD_100_SSC at 0.7V</b>					
T <sub>DC</sub>	LCD_100 Duty Cycle	Measured at 0V differential	45	55	%
T <sub>PERIOD</sub>	100 MHz LCD_100 Period	Measured at 0V differential at 0.1s	9.99900	10.0010	ns
T <sub>PERIODSS</sub>	100 MHz LCD_100 Period, SSC -0.5%	Measured at 0V differential at 0.1s	10.02406	10.02607	ns
T <sub>PERIODAbs</sub>	100 MHz LCD_100 Absolute Period	Measured at 0V differential at 1 clock	9.74900	10.25100	ns
T <sub>PERI-ODSSAbs</sub>	100 MHz LCD_100 Absolute Period, SSC	Measured at 0V differential @ 1 clock	9.74906	10.3012	ns
T <sub>CCJ</sub>	LCD_100 Cycle to Cycle Jitter	Measured at 0V differential	-	250	ps
L <sub>ACC</sub>	LCD_100 Long Term Accuracy	Measured at 0V differential	-	100	ppm
T <sub>R</sub> / T <sub>F</sub>	LCD_100 Rising/Falling Slew Rate	Measured differentially from ±150 mV	2.5	8	V/ns
T <sub>RFM</sub>	Rise/Fall Matching	Measured single-endedly from ±75 mV	-	20	%
V <sub>HIGH</sub>	Voltage High			1.15	V
V <sub>LOW</sub>	Voltage Low		-0.3	-	V
V <sub>OX</sub>	Crossing Point Voltage at 0.7V Swing		300	550	mV
<b>PCI/PCIF at 3.3V</b>					
T <sub>DC</sub>	PCI Duty Cycle	Measurement at 1.5V	45	55	%
T <sub>PERIOD</sub>	Spread Disabled PCIF/PCI Period	Measurement at 1.5V	29.99700	30.00300	ns
T <sub>PERIODSS</sub>	Spread Enabled PCIF/PCI Period	Measurement at 1.5V	30.08421	30.23459	ns
T <sub>PERIODAbs</sub>	Spread Disabled PCIF/PCI Period	Measurement at 1.5V	29.49700	30.50300	ns
T <sub>PERI-ODSSAbs</sub>	Spread Enabled PCIF/PCI Period	Measurement at 1.5V	29.56617	30.58421	ns
T <sub>HIGH</sub>	Spread Enabled PCIF and PCI high time	Measurement at 2V	12.27095	16.27995	ns
T <sub>LOW</sub>	Spread Enabled PCIF and PCI low time	Measurement at 0.8V	11.87095	16.07995	ns
T <sub>HIGH</sub>	Spread Disabled PCIF and PCI high time	Measurement at 2.0V	12.27365	16.27665	ns
T <sub>LOW</sub>	Spread Disabled PCIF and PCI low time	Measurement at 0.8V	11.87365	16.07665	ns
T <sub>R</sub> / T <sub>F</sub>	PCIF/PCI Rising/Falling Slew Rate	Measured between 0.8V and 2.0V	1.0	4.0	V/ns
T <sub>SKEW</sub>	Any PCI clock to Any PCI clock Skew	Measurement at 1.5V	-	1000	ps
T <sub>CCJ</sub>	PCIF and PCI Cycle to Cycle Jitter	Measurement at 1.5V	-	500	ps
L <sub>ACC</sub>	PCIF/PCI Long Term Accuracy	Measurement at 1.5V	-	100	ppm
<b>48_M at 3.3V</b>					
T <sub>DC</sub>	Duty Cycle	Measurement at 1.5V	45	55	%
T <sub>PERIOD</sub>	Period	Measurement at 1.5V	20.83125	20.83542	ns
T <sub>PERIODAbs</sub>	Absolute Period	Measurement at 1.5V	20.48125	21.18542	ns
T <sub>HIGH</sub>	48_M High time	Measurement at 2V	8.216563	11.15198	ns
T <sub>LOW</sub>	48_M Low time	Measurement at 0.8V	7.816563	10.95198	ns
T <sub>R</sub> / T <sub>F</sub>	Rising and Falling Edge Rate	Measured between 0.8V and 2.0V	1.0	2.0	V/ns
T <sub>CCJ</sub>	Cycle to Cycle Jitter	Measurement at 1.5V	-	350	ps
L <sub>ACC</sub>	48M Long Term Accuracy	Measurement at 1.5V	-	100	ppm

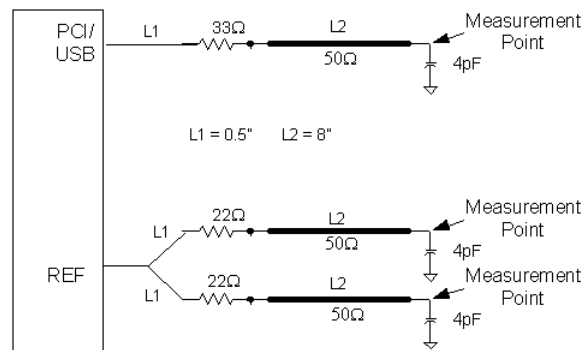
**AC Electrical Specifications** (continued)

Parameter	Description	Condition	Min.	Max.	Unit
<b>27M_NSS/27M_SS at 3.3V</b>					
T <sub>DC</sub>	Duty Cycle	Measurement at 1.5V	45	55	%
T <sub>PERIOD</sub>	Spread Disabled 27M Period	Measurement at 1.5V	37.0359 4	37.0381 3	ns
	Spread Enabled 27M Period	Measurement at 1.5V	37.0359 4	37.0381 3	ns
T <sub>R</sub> / T <sub>F</sub>	Rising and Falling Edge Rate	Measured between 0.4V and 2.0V	1.0	4.0	V/ns
T <sub>CCJ</sub>	Cycle to Cycle Jitter	Measurement at 1.5V	–	200	ps
L <sub>ACC</sub>	27_M Long Term Accuracy	Measured at crossing point V <sub>Ox</sub>	–	50	ppm
<b>REF</b>					
T <sub>DC</sub>	REF Duty Cycle	Measurement at 1.5V	45	55	%
T <sub>PERIOD</sub>	REF Period	Measurement at 1.5V	69.82033	69.86224	ns
T <sub>PERIODAbs</sub>	REF Absolute Period	Measurement at 1.5V	68.83429	70.84826	ns
T <sub>HIGH</sub>	REF High time	Measurement at 2V	29.97543	38.46654	ns
T <sub>LOW</sub>	REF Low time	Measurement at 0.8V	29.57543	38.26654	ns
T <sub>R</sub> / T <sub>F</sub>	REF Rising and Falling Edge Rate	Measured between 0.8V and 2.0V	1.0	4.0	V/ns
T <sub>SKEW</sub>	REF Clock to REF Clock	Measurement at 1.5V	–	500	ps
T <sub>CCJ</sub>	REF Cycle to Cycle Jitter	Measurement at 1.5V	–	1000	ps
L <sub>ACC</sub>	Long Term Accuracy	Measurement at 1.5V	–	100	ppm
<b>ENABLE/DISABLE and SET-UP</b>					
T <sub>STABLE</sub>	Clock Stabilization from Power-up		–	1.8	ms
T <sub>SS</sub>	Stopclock Set-up Time		10.0	–	ns

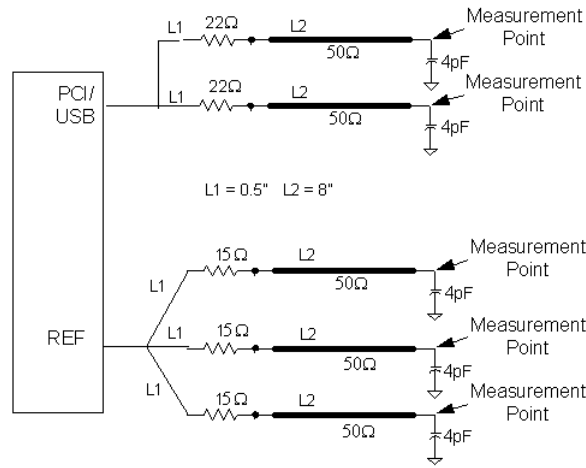
**Test and Measurement Set-up**

**For Single-ended Signals and Reference**

The following diagram shows test load configurations for the single-ended PCI, USB, and REF output signals.

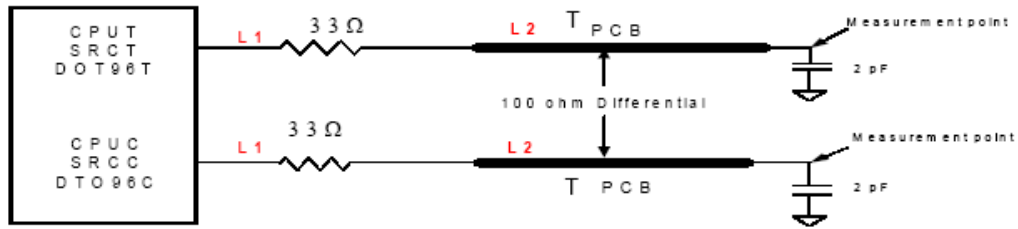


**Figure 15. Single-ended Load Configuration Low Drive Option**

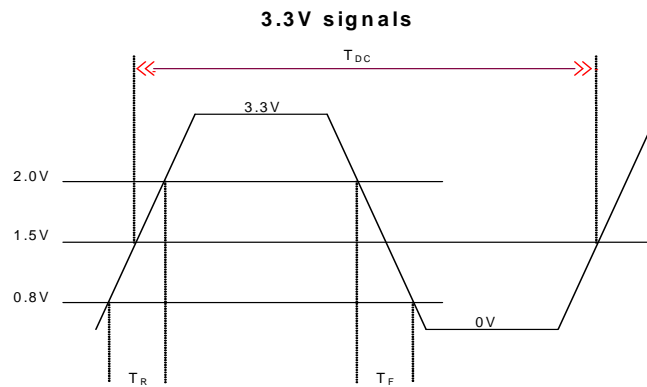


**Figure 16. Single-ended Load Configuration High Drive Option**

The following diagram shows the test load configuration for the differential CPU and SRC outputs.



**Figure 17. 0.8V Differential Load Configuration**



**Figure 18. Single-ended Output Signals (for AC Parameters Measurement)**

**Ordering Information**

Part Number	Package Type	Product Flow
<b>Lead-free</b>		
CY28547LFXC	72-pin QFN	Commercial, 0° to 85°C

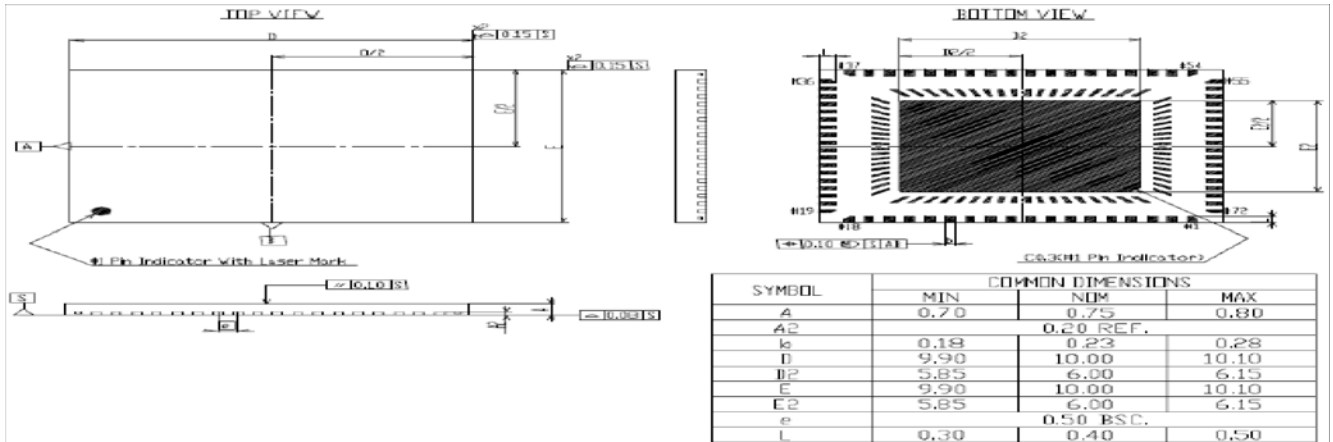
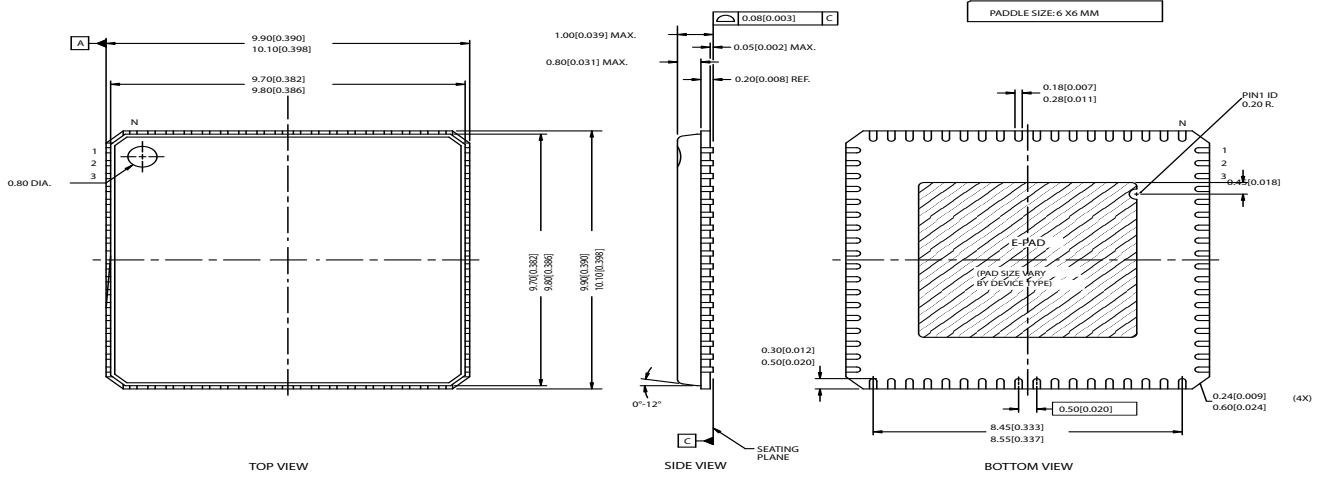
**Ordering Information**

CY28547LFXCT	72-pin QFN-Tape and Reel	Commercial, 0° to 85°C
--------------	--------------------------	------------------------

**Package Diagram**

**72-Lead QFN 10 x 10 mm (Punch Version) LF72A**

DIMENSIONS IN MM [INCHES] MIN. MAX.  
 REFERENCE JEDEC MO-220  
 WEIGHT: 0.23 GRAMS



**Document History Page**

Document Title: CY28547 Clock Generator for Intel® CK410M/CK505			
Document Number: 001-05103			
REV.	Issue Date	Orig. of Change	Description of Change
1.0	See ECN	RGL	New data sheet
1.1	See ECN	RGL/XLZ	Modify the definition of pin 9, 27, 32 and 39 Re-arrange control register map Update AC Electrical Specifications table
1.2	See ECN	RGL	Modify the pin description table Update the default values in the control register bytes 7, 8, 9, 11, 12, 14, and 15
1.3	12/28/06	JMA	1. Modified Revision ID Bit from 0010 to 0011 2. Set Byte 12 <7> from DIAG_EN to Reserved 3. Set Byte 12 <6> from CPU_PLL Status to Reserved 4. Set Byte 12 <5> from Video_PLL Status to Reserved 5. Set Byte 12 <4> from Fixed_PLL Status to Reserved 6. Edited Figure 15 and 16 Termination Resistor for double load 12-ohm to 22-ohm 7. Edited Figure 15 and 16 Load from 5pF to 4pF. 8. Changed CPU Vox_min from 250ps to 300ps 9. Changed SRC Vox_min from 180ps to 300ps 10. Changed LCD Vox_min from 250ps to 300ps 11. Changed DOTVox_min from 250ps to 300ps
1.4	10/31/07	JMA	Added Mitsui package



## ClockBuilder Pro

One-click access to Timing tools, documentation, software, source code libraries & more. Available for Windows and iOS (CBGo only).

[www.silabs.com/CBPro](http://www.silabs.com/CBPro)



**Timing Portfolio**  
[www.silabs.com/timing](http://www.silabs.com/timing)



**SW/HW**  
[www.silabs.com/CBPro](http://www.silabs.com/CBPro)



**Quality**  
[www.silabs.com/quality](http://www.silabs.com/quality)



**Support and Community**  
[community.silabs.com](http://community.silabs.com)

### Disclaimer

Silicon Laboratories intends to provide customers with the latest, accurate, and in-depth documentation of all peripherals and modules available for system and software implementers using or intending to use the Silicon Laboratories products. Characterization data, available modules and peripherals, memory sizes and memory addresses refer to each specific device, and "Typical" parameters provided can and do vary in different applications. Application examples described herein are for illustrative purposes only. Silicon Laboratories reserves the right to make changes without further notice and limitation to product information, specifications, and descriptions herein, and does not give warranties as to the accuracy or completeness of the included information. Silicon Laboratories shall have no liability for the consequences of use of the information supplied herein. This document does not imply or express copyright licenses granted hereunder to design or fabricate any integrated circuits. The products must not be used within any Life Support System without the specific written consent of Silicon Laboratories. A "Life Support System" is any product or system intended to support or sustain life and/or health, which, if it fails, can be reasonably expected to result in significant personal injury or death. Silicon Laboratories products are generally not intended for military applications. Silicon Laboratories products shall under no circumstances be used in weapons of mass destruction including (but not limited to) nuclear, biological or chemical weapons, or missiles capable of delivering such weapons.

### Trademark Information

Silicon Laboratories Inc., Silicon Laboratories, Silicon Labs, SiLabs and the Silicon Labs logo, CMEMS®, EFM, EFM32, EFR, Energy Micro, Energy Micro logo and combinations thereof, "the world's most energy friendly microcontrollers", Ember®, EZLink®, EZMac®, EZRadio®, EZRadioPRO®, DSPLL®, ISOmodem®, Precision32®, ProSLIC®, SiPHY®, USBXpress® and others are trademarks or registered trademarks of Silicon Laboratories Inc. ARM, CORTEX, Cortex-M3 and THUMB are trademarks or registered trademarks of ARM Holdings. Keil is a registered trademark of ARM Limited. All other products or brand names mentioned herein are trademarks of their respective holders.



Silicon Laboratories Inc.  
400 West Cesar Chavez  
Austin, TX 78701  
USA

<http://www.silabs.com>

## Looking for pricing, stock, or lifecycle information?

Click below to explore more details on WIN SOURCE:

 [View CY28547LFXC on WIN SOURCE](#)

 [Silicon Labs](#) Information

## Optimize Your Supply Chain with WIN SOURCE Solutions

-  Global Sourcing Solution
-  Obsolete Management
-  Cost Control Management
-  Shortage Management
-  Alternative Solution
-  Excess Inventory Management