



**THE DATASHEET OF  
PT8A974PE**



## Features

- The PT8A9701 works as the encoder and the PT8A974/974L works as the decoder
- Nine output pins, 5 for forward, backward, left, right and turbo functions, and 3 functional keys
- Operation power supply for PT8A9701: 3V to 12V (with series resistor)
- Auto power-off if no key pressed (PT8A9701)
- Motor current limit to meet toy safety standard HD271 (PT8A974/974L)
- Low operating current
- On-chip oscillator with an external resistor
- On-chip reversing amplifiers
- Built-in 3.7V Zener (Vz) (PT8A974) and 3.1V Zener (Vz) (PT8A974L)
- Few external components needed

## Block Diagram

**Figure 1. Block Diagram of PT8A9701**

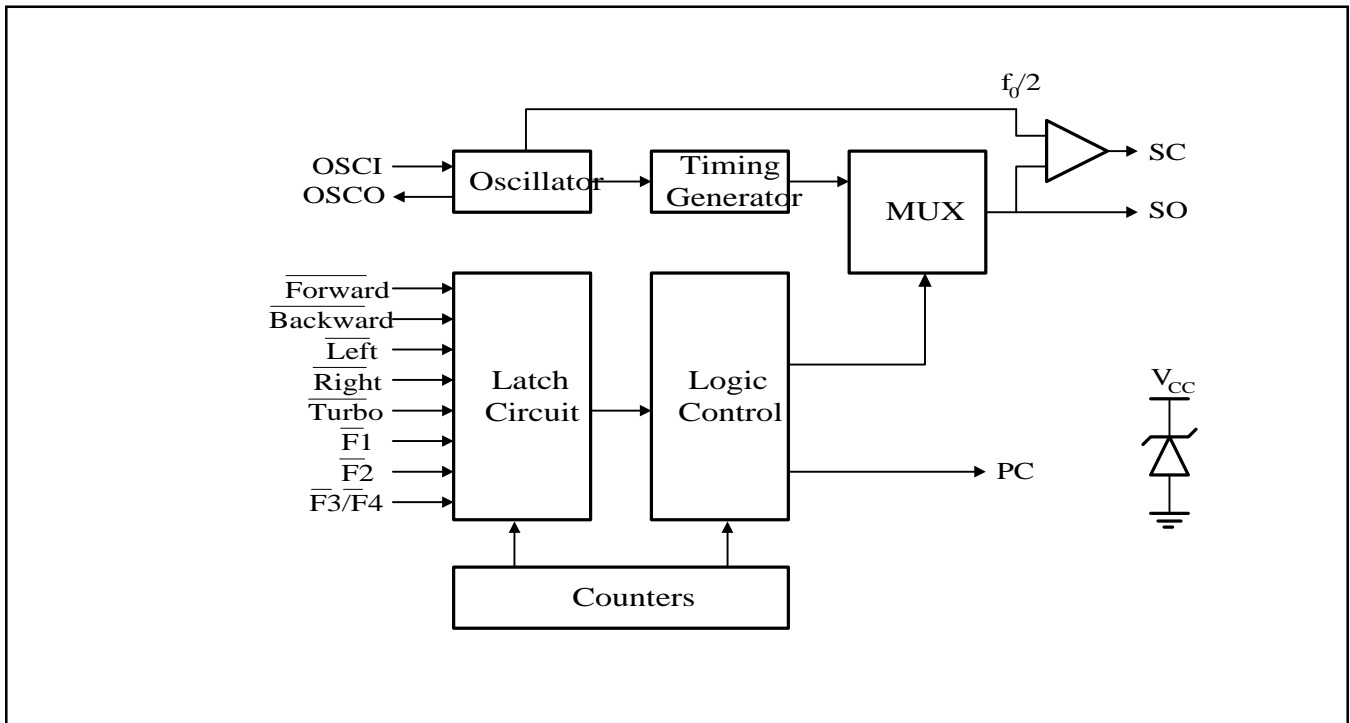

## General Description

The PT8A9701 and PT8A974/974L is a pair of CMOS LSIs designed for remote controlled toy car application. They have eight control keys for controlling the corresponding motion, i.e., forward, backward, left, right, turbo and 3 functional keys, of the remote controlled car. They also have Forward (Backward) and Turbo combination application.

## Ordering Information

Device Name	Encoder	Decoder	
Part No.	PT8A9701PE	PT8A974PE	PT8A974LPE
Package	Lead free 16-pin PDIP	Lead free 20-pin PDIP	

**Note:**

Adding E= Pb-free or Pb-free and Green

Adding X suffix=Tape/Reel

Figure 2. Block Diagram of PT8A974/974L

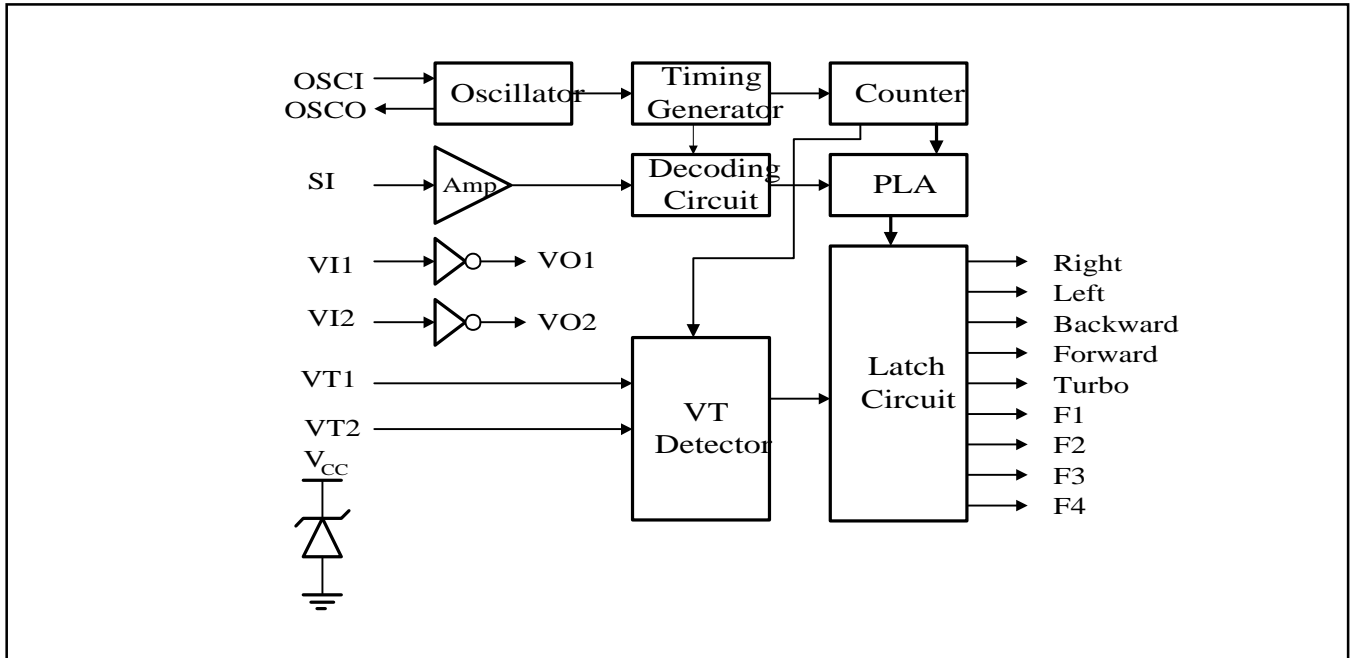

### Package and Pin Assignment

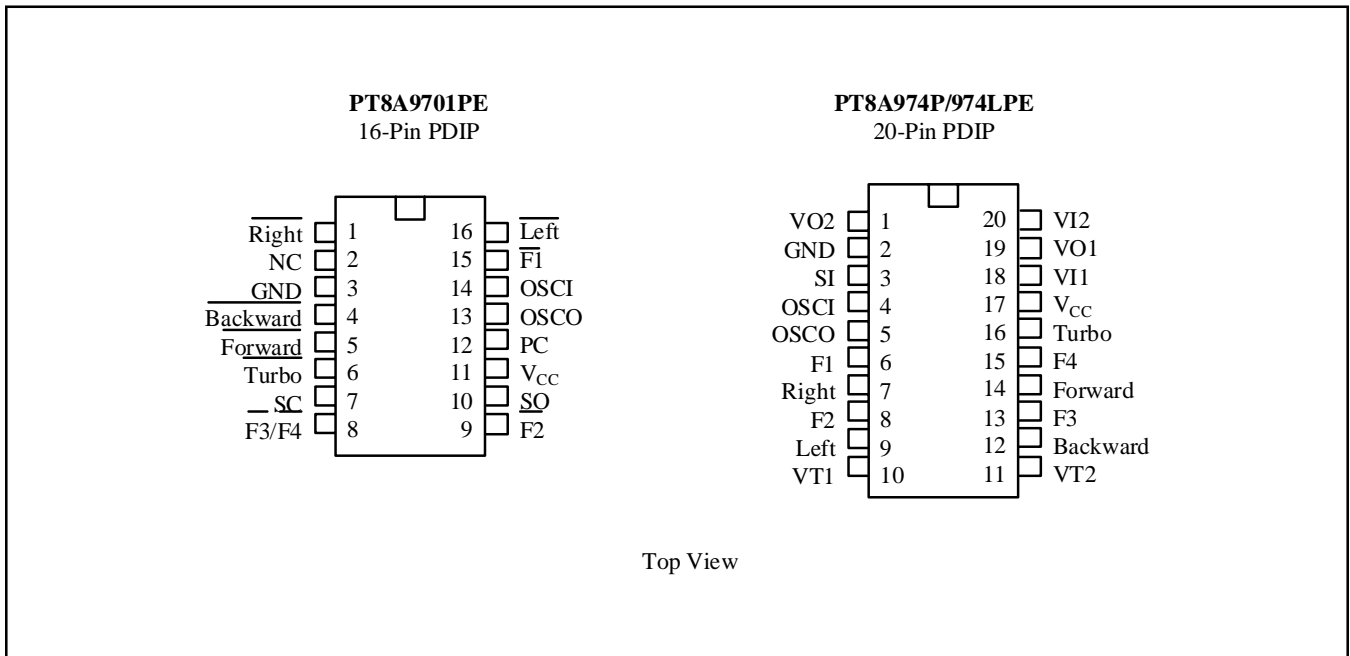

## Pin Description

Table 1. Pin Description of PT8A9701

Pin No	Pin Name	Type	Description
1	$\overline{\text{Right}}$	I	Rightward function selected if this pin connected to GND
2	NC	-	No connection
3	GND	GND	Ground
4	$\overline{\text{Backward}}$	I	Backward function selected if this pin connected to GND
5	$\overline{\text{Forward}}$	I	Forward function selected if this pin connected to GND
6	$\overline{\text{Turbo}}$	I	Turbo function selected if this pin connected to GND
7	SC	O	Output pin of the encoding signal with carrier frequency
8	$\overline{\text{F3/F4}}$	I	Able to toggle between Function 3 and Function 4 if connected to GND
9	$\overline{\text{F2}}$	I	Function 2 selected if connected to GND
10	SO	O	Output pin of the encoding signal without carrier frequency
11	V <sub>cc</sub>	P	Power supply
12	PC	O	Power control output pin
13	OSCO	O	Oscillator output pin
14	OSCI	I	Oscillator input pin
15	$\overline{\text{F1}}$	I	Function 1 selected if connected to GND
16	$\overline{\text{Left}}$	I	Leftward function selected if this pin connected to GND

**Table 2. Pin Description of PT8A974/974L**

Pin No	Pin Name	Type	Description
1, 19	VO2, VO1	O	Output pins of amplifiers 1 and 2
2	GND	GND	Ground
3	SI	I	Input pin for encoded signal
4	OSCI	I	Oscillator input pin
5	OSCO	O	Oscillator output pin
6	F1	O	F1 function output pin
7	Right	O	Rightward output pin
8	F2	O	F2 function output pin
9	Left	O	Leftward output pin
10	VT1	I	Auto shut-off input pin: If voltage on VT1 pin is over $0.095V_{CC}$ for 3 sec, all outputs will be shut off automatically.
11	VT2	I	Auto shut-off input pin: If voltage on VT2 pin is over $0.095V_{CC}$ for 3 sec, all outputs will be shut off automatically.
12	Backward	O	Backward output pin
13	F3	O	F3 function output pin
14	Forward	O	Forward output pin
15	F4	O	F4 function output pin
16	Turbo	O	Turbo output pin
17	$V_{CC}$	P	Power supply
18, 20	VI1,VI2	I	Input pins of amplifiers 1 and 2

## Functional Description

In normal operation without 'Turbo', forward (backward) output pin of the decoder PT8A974P/974LP sends out a 60Hz signal. In operation with 'Forward (Backward)' and 'Turbo' combined, the output signal will be completely high. This function is depicted in Table 3.

## Timing Diagram

### Data Format

See Figure 4.

## Coding Method

Each trigger pin is triggered by corresponding bit of data in format of "1". The data string is 16-bit and divided to four segments, i.e., Start Code, Data Code, Parity Code and End code, where

Start Code = 11110.

Data Code = 

F	B	T	R	L	F1	F3	F4	F2
---	---	---	---	---	----	----	----	----

F = Forward                      B = Backward                      T = Turbo  
R = Right                          L = Left                              F1 = Function 1  
F2 = Function 2                  F3 = Function 3                  F4 = Function 4

Parity Code = Even parity check result

End Code is for data latch.

Data code can be any combination of F, B, T, R, L, F1, F2, F3 and F4 except F&B and R&L.

**Table 3**

Input to PT8A970P	Output from PT8A974P974L		
	Forward	Backward	Turbo
Forward	60Hz	Low	Low
Backward	Low	60Hz	Low
Forward + Turbo	High	Low	High
Backward + Turbo	Low	High	High

**Figure 4. Data Format**

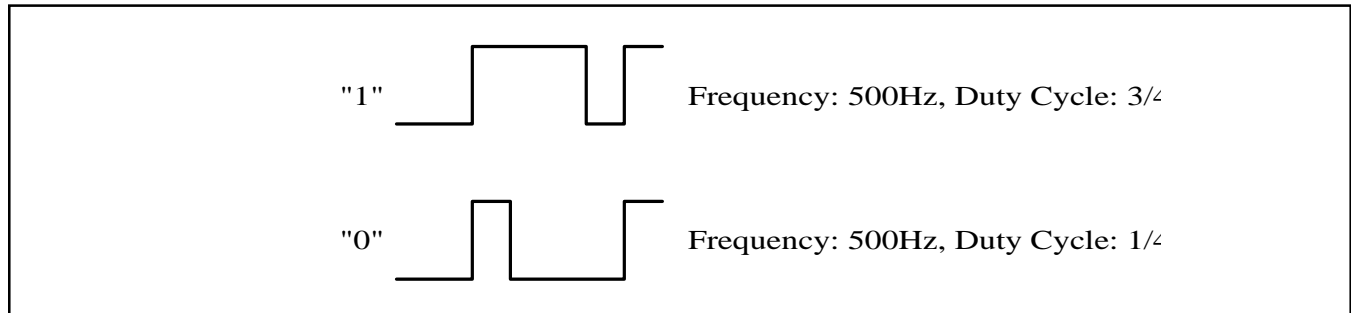

## Maximum Ratings

(Above which the useful life may be impaired. For user guidelines, not tested)

### Maximum Ratings PT8A9701

Storage Temperature .....	-25°C to +85°C
Ambient Temperature with Power Applied .....	0°C to +70°C
Supply Voltage to Ground Potential (Inputs & V <sub>CC</sub> Only) .....	-0.5 to +5.5V
Supply Voltage to Ground Potential (Outputs & D/O Only) .....	-0.5 to +5.5V
DC Input Voltage .....	-0.5 to +5.5V
DC Output Current .....	20mA
Power Dissipation .....	500mW

### Maximum Ratings PT8A974

Storage Temperature .....	-25°C to +85°C
Ambient Temperature with Power Applied .....	0°C to +70°C
Supply Voltage to Ground Potential (Inputs & V <sub>CC</sub> Only) .....	-0.5 to +5.5V
Supply Voltage to Ground Potential (Outputs & D/O Only) .....	-0.5 to +5.5V
DC Input Voltage .....	-0.5 to +5.5V
DC Output Current .....	30mA
Power Dissipation .....	500mW

### Maximum Ratings PT8A974L

Storage Temperature .....	-25°C to +85°C
Ambient Temperature with Power Applied .....	0°C to +70°C
Supply Voltage to Ground Potential (Inputs & V <sub>CC</sub> Only) .....	-0.5 to +5.0V
Supply Voltage to Ground Potential (Outputs & D/O Only) .....	-0.5 to +5.0V
DC Input Voltage .....	-0.5 to +5.0V
DC Output Current .....	30mA
Power Dissipation .....	500mW

**Note:**

Stresses greater than those listed under MAXIMUM RATINGS may cause permanent damage to the device. This is a stress rating only and functional operation of the device at these or any other conditions above those indicated in the operational sections of this specification is not implied. Exposure to absolute maximum rating conditions for extended periods may affect reliability.

## Recommended Operation Conditions

**Table 4. Recommended Operation Conditions**

Sym	Description	Min	Typ	Max	Units
I <sub>CC</sub>	Supply Current for PT8A974P			30	mA
	Supply Current for PT8A974LP			30	mA
V <sub>IH</sub>	Input HIGH Voltage	0.7V <sub>CC</sub>			V
V <sub>IL</sub>	Input LOW Voltage		0	0.3V <sub>CC</sub>	V
F <sub>OSC</sub>	Oscillator Frequency	109	128	146	kHz
T <sub>A</sub>	Operation Temperature	0		70	°C

## DC Electrical Characteristics

**Table 5. DC Electrical Characteristics of PT8A9701**

Sym	Description	Test Conditions	Min	Typ	Max	Units
V <sub>Z</sub>	Voltage of Zenner	I <sub>Z</sub> = 2~30mA	3.4	3.7	4.0	V
I <sub>OH</sub>	Output HIGH Current - PC Pin	V <sub>OH</sub> = V <sub>CC</sub> -0.5V	-3	-5		mA
	Output HIGH Currentl - SC and SO Pins		-3	-5		mA
	Output HIGH Current - OSCO Pin		-200		-1000	uA
I <sub>OL</sub>	Output LOW Current - PC Pin	V <sub>OL</sub> = 0.5V	2	3		mA
	Output LOW Currentl - SC and SO Pins		2	3		mA
	Output LOW Current - OSCO Pin		200		1000	uA
I <sub>IH</sub>	Input HIGH Current - Forward, Backward, Left, Right, Turbo, F1, F2, F3/F4 and OSCI Pins	V <sub>IH</sub> = V <sub>CC</sub>			1	uA
I <sub>IL</sub>	Input LOW Current - Forward, Backward, Left, Right, Turbo, F1, F2 and F3/F4 Pins	V <sub>IL</sub> = 0V	-20	-40	-100	uA
	Input LOW Current - OSCI Pin				-10	uA

**Note:** These specifications apply for V<sub>CC</sub> = 3.5V and T<sub>A</sub> = 25°C, unless otherwise specified.

**Table 6. DC Electrical Characteristics of PT8A974/974L**

Sym	Description	Test Conditions	Min	Typ	Max	Units
I <sub>OH</sub>	Output HIGH Current - VO1, VO2 and OSCO Pins	V <sub>OH</sub> = V <sub>CC</sub> -0.5V	-300		-800	uA
	Output HIGH Current - Forward, Backward, Left and Right Pins		-3			mA
	Output HIGH Current - Turbo, F1, F2, F3 and F4 Pins		-3			
I <sub>OL</sub>	Output LOW Current - VO1, VO2 and OSCO Pins	V <sub>OL</sub> = 0.5V	200		1000	uA
	Output LOW Current - Forward, Backward, Left, Right and Turbo Pins		2	3		mA
	Output LOW Current - F1, F2, F3 and F4 Pins		2	3		
I <sub>IH</sub>	Input HIGH Current - OSC1, V11, V12 and SI Pins	V <sub>IN</sub> = V <sub>CC</sub>			10	uA
	Input HIGH Current - VT1 and VT2 Pins				50	uA
I <sub>IL</sub>	Input LOW Current - OSC1, VT1, VT2, V11, V12 and SI Pin	V <sub>IN</sub> = 0V			-10	uA
VT	Over-Current Limit - VT1 and VT2 Pins for 974P		0.30		0.40	V
	Over-Current Limit - VT1 and VT2 Pins for 974LP		0.25		0.35	V
V <sub>Z</sub>	Voltage of Zenner - V <sub>CC</sub> Pin of PT8A974P	I <sub>Z</sub> = 2~30mA	3.4	3.7	4	V
	Voltage of Zenner - V <sub>CC</sub> of PT8A974LP		2.8	3.1	3.4	V

**Note:** These specifications apply for T<sub>A</sub> = 25°C, V<sub>CC</sub> = 3.5V (974), V<sub>CC</sub> = 3.0V (974L), unless otherwise specified.

## AC Electrical Characteristics

**Table 7. AC Electrical Characteristics of PT8A9701**

Sym	Description	Test Conditions	Min	Typ	Max	Units
$f_{OSC}$ (Note2)	Oscillator Frequency	$R_f = 200k\Omega$	109	128	146	kHz
$t_{FUN}$	Period of Function Code	$f_{OSC} = 128kHz$	1.7	2	2.3	ms
$t_{STA}$	Start-Code Period	$f_{OSC} = 128kHz$	1.7	2	2.3	ms
$f_{CSC}$	Carrier Frequency	$f_{OSC} = 128kHz$		64		kHz
$t_{OFF}$	Auto-off Time	$f_{OSC} = 128kHz$		2		s
$V_{CC}$	Power Supply Range	-	3	9	12	V
$I_{CC}$	Supply Current	Output Unloaded			30	mA

**Notes:**

1. These specifications apply for  $V_{CC} = 3.5V$  and  $T_A = 25^\circ C$ , unless otherwise specified.
2. The frequency of standard samples is tested on standard testing-board.

**Table 8. AC Electrical Characteristics of PT8A974/974L**

Sym	Description	Test Conditions	Min	Typ	Max	Units
$f_{OSC}$ (Note2)	Oscillator Frequency	$R_f = 200k\Omega$	109	128	146	kHz
$t_{FUN}$	Period of Function Code	$f_{OSC} = 128kHz$	1.7	2	2.3	ms
$t_{STA}$	Start-Code Period	$f_{OSC} = 128kHz$	1.7	2	2.3	ms
$I_{CC}$	Supply Current	Output Unloaded			30	mA

**Notes:**

1. These specifications apply for  $T_A = 25^\circ C$ ,  $V_{CC} = 3.5V$  (974),  $V_{CC} = 3.0V$  (974L), unless otherwise specified.
2. The frequency of standard samples is tested on standard testing-board.

Figure 5. Typical Application Circuit of PT8A9701

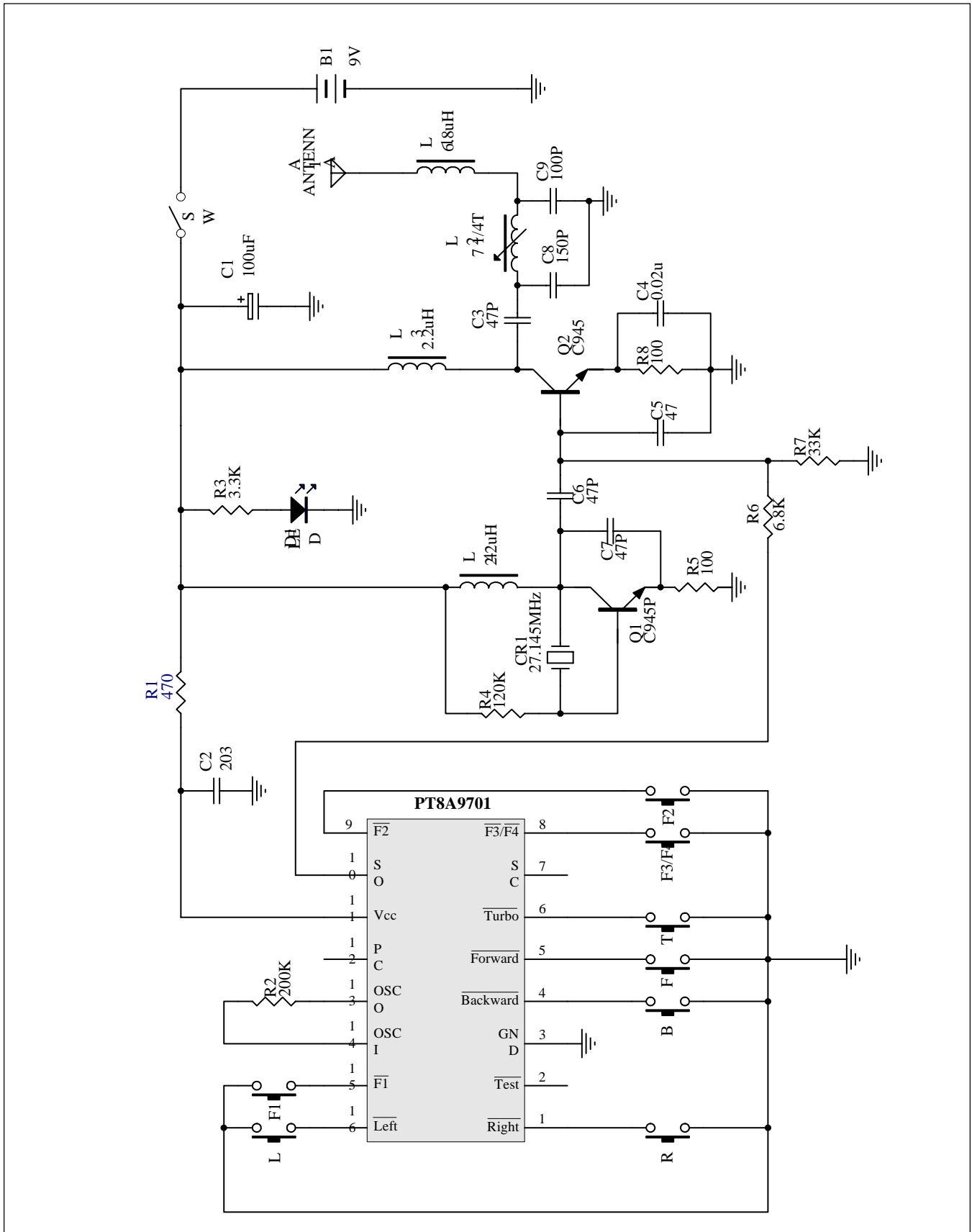
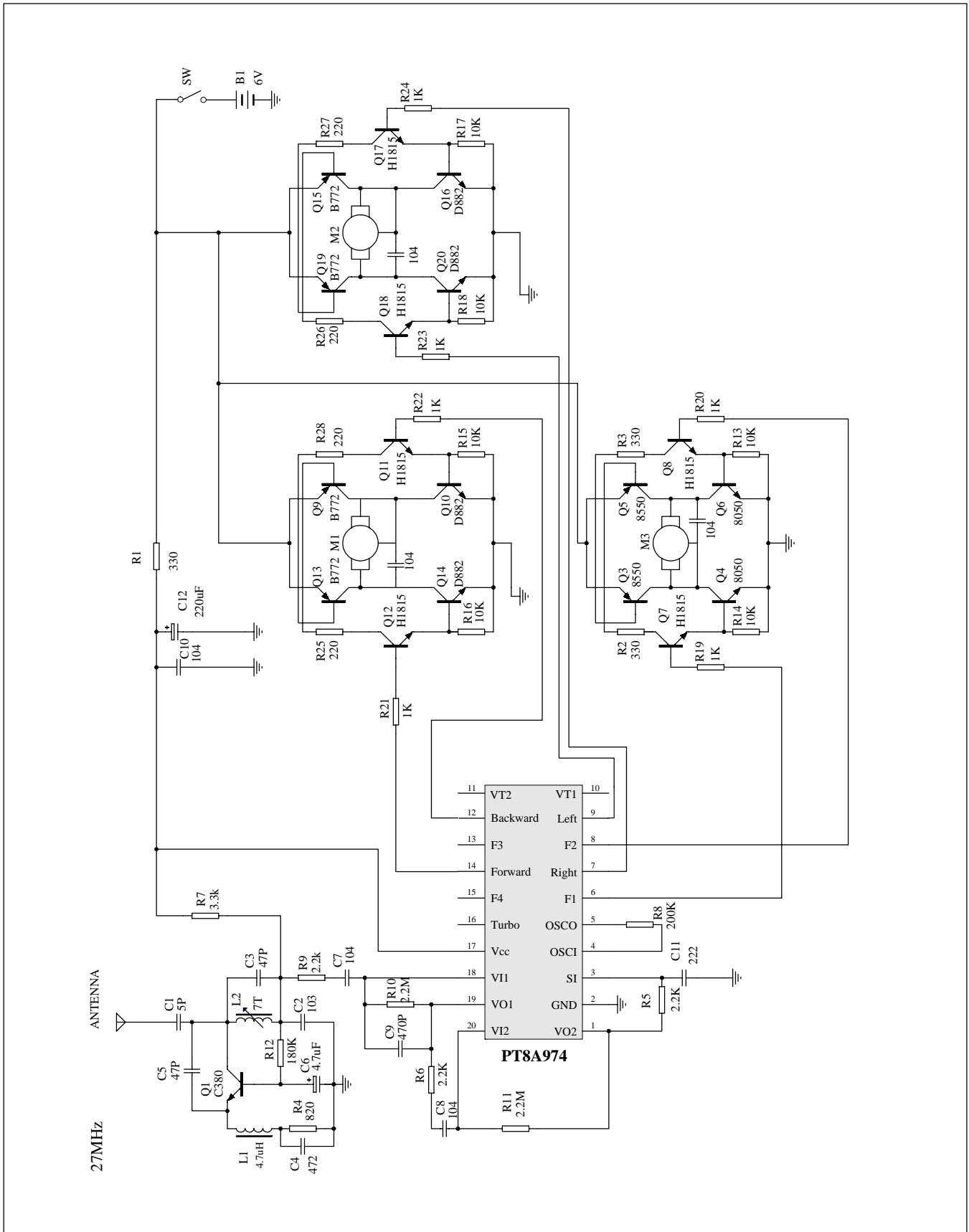
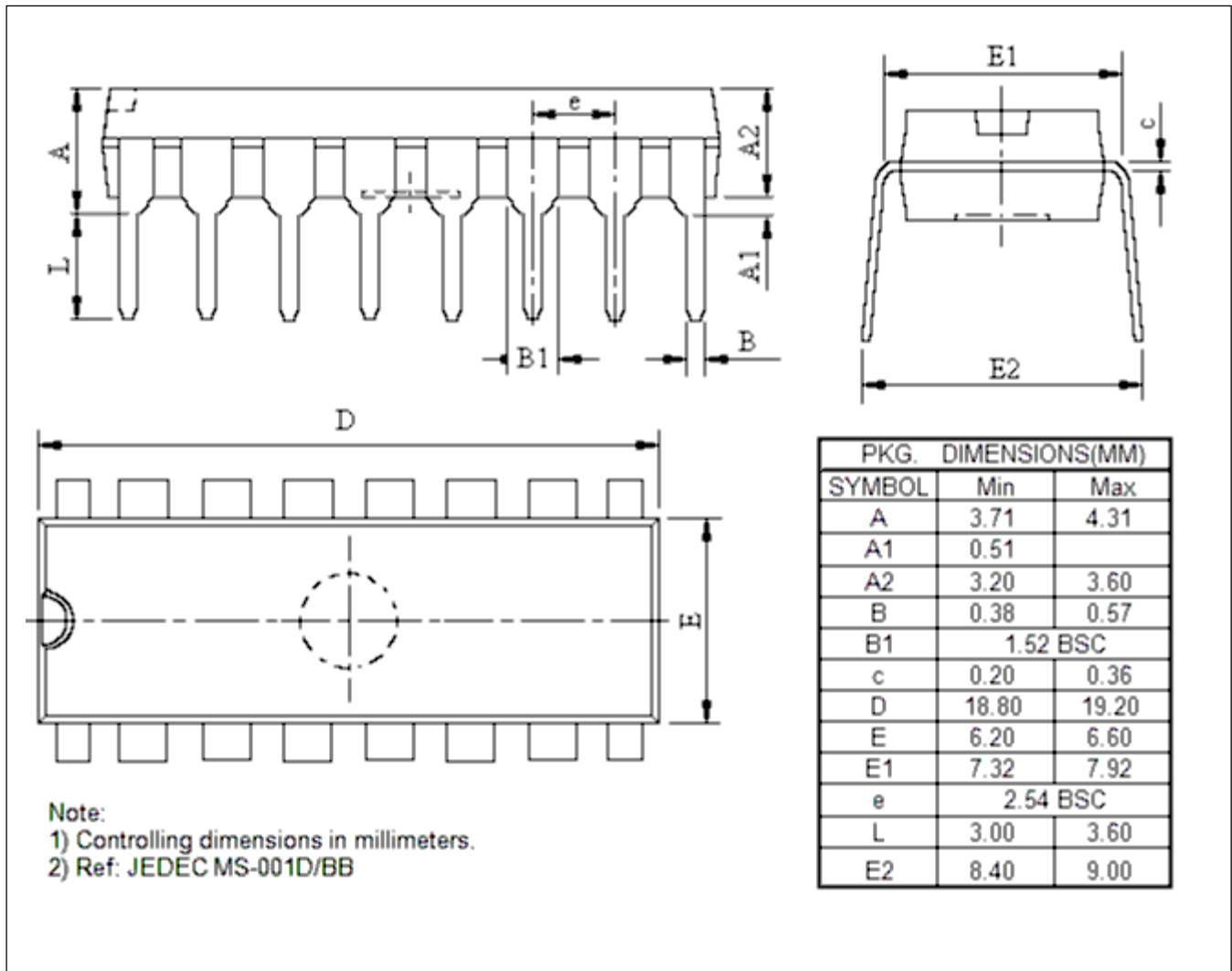

Figure 6. Typical Application Circuit of PT8A974



### Mechanical Information

16-pin DIP



20-pin DIP

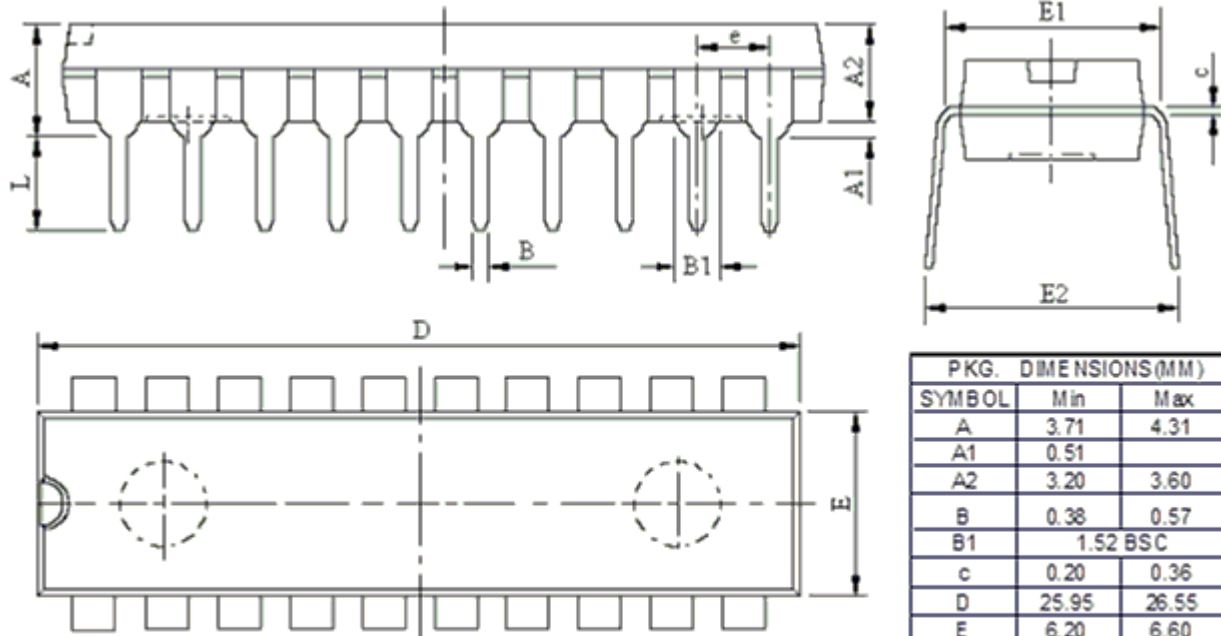

PKG. DIMENSIONS(MM)		
SYMBOL	Min	Max
A	3.71	4.31
A1	0.51	
A2	3.20	3.60
B	0.38	0.57
B1	1.52 BSC	
c	0.20	0.36
D	25.95	26.55
E	6.20	6.60
E1	7.32	7.92
e	2.54 BSC	
L	3.00	3.60
E2	8.40	9.00

Note:



- 1) Controlling dimensions in millimeters.
- 2) Ref: JEDECMS-001D/AD

Pericom Semiconductor Corporation • 1-800-435-2336 • www.pericom.com

Pericom Technology Incorporation reserves the right to make changes to its products or specifications at any time, without notice, in order to improve design or performance and to supply the best possible product. Pericom Technology does not assume any responsibility for use of any circuitry described other than the circuitry embodied in Pericom Technology product. The company makes no representations that circuitry described herein is free from patent infringement or other rights, of Pericom.

## Looking for pricing, stock, or lifecycle information?

Click below to explore more details on WIN SOURCE:

-  [View PT8A974PE on WIN SOURCE](#)
-  [Diodes Incorporated Information](#)

## Optimize Your Supply Chain with WIN SOURCE Solutions

-  Global Sourcing Solution
-  Obsolete Management
-  Cost Control Management
-  Shortage Management
-  Alternative Solution
-  Excess Inventory Management