



THE DATASHEET OF TUSB522PIRGET



TUSB522P 3.3 V Dual-Channel USB 3.1 GEN 1 Redriver, Equalizer

1 Features

- USB3.1 GEN1 5 Gbps, Dual-Channel Re-Driver with 3.3-V Power Supply
- Ultra-Low-Power Architecture
 - Active: 98 mA
 - U2, U3: 1.2 mA
 - Disconnect 265 μ A
 - Shutdown 60 μ A
- Optimal Receiver Equalization
 - of 3, 6, 9 dB at 2.5 GHz
- Output Driver De-emphasis of 0, 3.5, and 6 dB
- Automatic LFPS De-Emphasis Control to Meet USB 3.1 Certification Requirements
- No Host/Device-Side Requirement
- Hot-Plug Capable
- Industrial Temperature Range: -40°C to 85°C TUSB522PI
- Commercial Temperature Range: 0°C to 70°C TUSB522P

2 Applications

- Cell Phones
- Tablets
- Notebooks
- Desktops
- Docking Stations
- Backplanes and Active Cables

3 Description

The TUSB522P is a fourth generation, dual-channel, single-lane USB 3.1 GEN1 re-driver and signal conditioner supporting 5 Gbps. The device offers low power consumption on a 3.3 V supply with its ultra-low-power architecture. The re-driver also supports the USB 3.1 low power modes, which further reduces idle power consumption.

The dual-channel capability enables the system to maintain signal integrity on both transmit and receive data paths. The receiver equalization has three gain settings to overcome channel degradation from insertion loss and inter-symbol interference. These settings are controlled from the EQ pins. To compensate for transmission line losses, the output driver supports configuration of De-Emphasis with pins DE. Additionally, automatic LFPS De-Emphasis control allows for full USB 3.1 compliance. These settings allow optimal performance, increased signaling distance, and flexibility in placement of the TUSB522P in the USB 3.1 GEN1 path.

Device Information⁽¹⁾

PART NUMBER	PACKAGE	BODY SIZE (NOM)
TUSB522P	VQFN (24)	4.00 mm x 4.00 mm
TUSB522PI		

(1) For all available packages, see the orderable addendum at the end of the data sheet.

Simplified Schematic

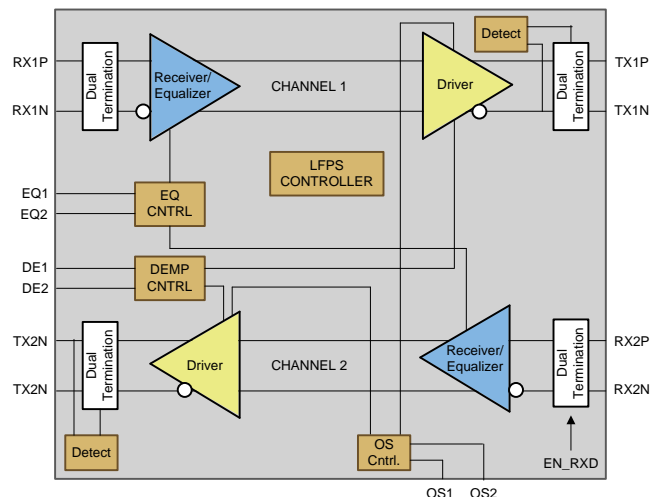
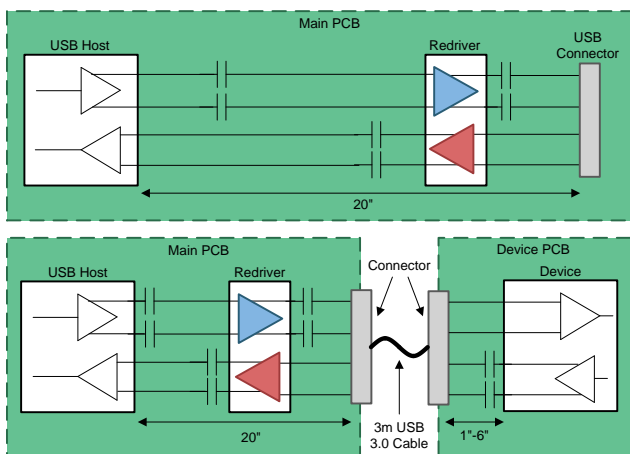

Copyright © 2016, Texas Instruments Incorporated



An IMPORTANT NOTICE at the end of this data sheet addresses availability, warranty, changes, use in safety-critical applications, intellectual property matters and other important disclaimers. PRODUCTION DATA.

Table of Contents

1 Features	1	7.4 Device Functional Modes.....	10
2 Applications	1	8 Application and Implementation	11
3 Description	1	8.1 Application Information.....	11
4 Revision History	2	8.2 Typical Application	11
5 Pin Configuration and Functions	3	9 Power Supply Recommendations	13
6 Specifications	4	10 Layout	14
6.1 Absolute Maximum Ratings	4	10.1 Layout Guidelines	14
6.2 ESD Ratings.....	4	10.2 Layout Example	14
6.3 Recommended Operating Conditions.....	4	11 Device and Documentation Support	15
6.4 Thermal Information	5	11.1 Documentation Support	15
6.5 Electrical Characteristics, Power Supply	5	11.2 Related Links	15
6.6 Electrical Characteristics, DC	5	11.3 Receiving Notification of Documentation Updates	15
6.7 Electrical Characteristics, AC.....	6	11.4 Community Resources.....	15
7 Detailed Description	8	11.5 Trademarks	15
7.1 Overview	8	11.6 Electrostatic Discharge Caution.....	15
7.2 Functional Block Diagram	8	11.7 Glossary	15
7.3 Feature Description.....	9	12 Mechanical, Packaging, and Orderable Information	15

4 Revision History

Changes from Revision C (May 2019) to Revision D	Page
• Changed pin 11 From: TX1N To: TX2N and pin 12 From: TX1P To: TX2P in Figure 2	11
<hr/>	
Changes from Revision B (November 2017) to Revision C	Page
• Deleted the RGE0024F mechanical pages	15
<hr/>	
Changes from Revision A (October 2016) to Revision B	Page
• Changed the values in the FOR OS = HIGH column of Table 1	10
<hr/>	
Changes from Original (July 2016) to Revision A	Page
• Changed the device From Preview To: Production.....	1

5 Pin Configuration and Functions

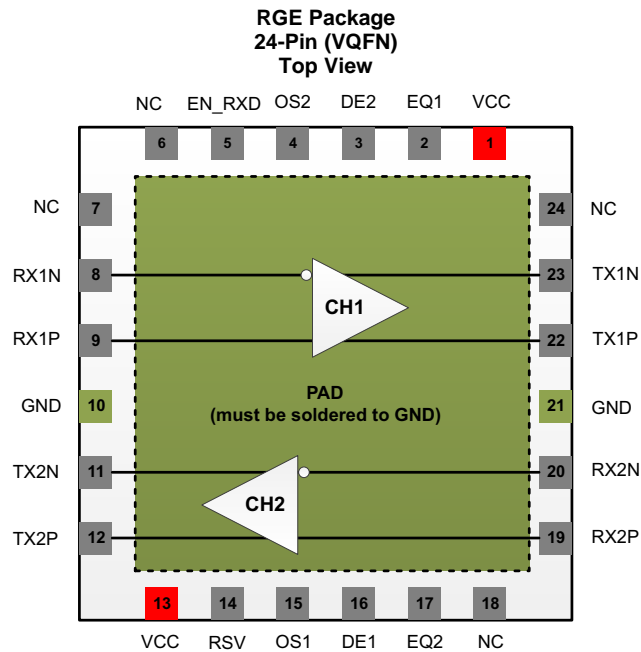

Pin Functions

PIN		I/O	DESCRIPTION
NAME	NO.		
RX1N	8	Differential I	Differential input for 5 Gbps negative signal on Channel 1
RX1P	9	Differential I	Differential input for 5 Gbps positive signal on Channel 1
TX1N	23	Differential O	Differential output for 5 Gbps negative signal on Channel 1
TX1P	22	Differential O	Differential output for 5 Gbps positive signal on Channel 1
RX2N	20	Differential I	Differential input for 5 Gbps negative signal on Channel 2
RX2P	19	Differential I	Differential input for 5 Gbps positive signal on Channel 2
TX2N	11	Differential O	Differential output for 5 Gbps negative signal on Channel 2
TX2P	12	Differential O	Differential output for 5 Gbps positive signal on Channel 2
EQ1	2	I, CMOS	Sets the receiver equalizer gain for Channel 1. 3-state input with integrated pull-up and pull-down resistors. EQ1 = Low = 3 dB EQ1 = Mid = 6 dB EQ1 = High = 9 dB
DE1	16	I, CMOS	Sets the output de-emphasis for Channel 1. 3-state input with integrated pull-up and pull-down resistors. DE1 = Low = 0 dB DE1 = Mid = -3.5 dB DE1 = High = -6.2 dB Note: When OS = Low
OS1	15	I, CMOS	Sets the output swing (differential voltage amplitude) for Channel 1. 2-state input with an integrated pull down resistor. OS1 = Low = 0.9 mV OS1 = High = 1.1 mV
EQ2	17	I, CMOS	Sets the receiver equalizer gain for Channel 2. 3-state input with integrated pull-up and pull-down resistors. EQ2 = Low = 3 dB EQ2 = Mid = 6 dB EQ2 = High = 9 dB

Pin Functions (continued)

PIN		I/O	DESCRIPTION
NAME	NO.		
DE2	3	I, CMOS	Sets the output de-emphasis for Channel 2. 3-state input with integrated pull-up and pull-down resistors. DE2 = Low = 0 dB DE2 = Mid = -3.5 dB DE2 = High = -6.2 dB Note: When OS = Low
OS2	4	I, CMOS	Sets the output swing (differential voltage amplitude) for Channel 2. 2-state input with an integrated pull down resistor. OS2 = Low = 0.9 mV OS2 = High = 1.1 mV
EN_RXD	5	I, CMOS	Enable. The device has a 660-k Ω pulldown resistor. Device is active when EN_RXD = High. Drive actively high or install a pullup resistor (recommend 4.7 K Ω) for normal operation. Does reset state machine.
RSV	14	I, CMOS	Reserved. Can be left as No-connect.
VCC	1, 13	P	Positive Power Supply. Power Supply is 3.3 V.
GND	10, 21, PAD	G	Ground. PAD must be connected to Ground. Pins 10, 21 can be connected to Ground or left unconnected.
NC	6, 7, 18, 24		No Connection. These pins can be tied to any desired voltages including connecting them to GND.

6 Specifications

6.1 Absolute Maximum Ratings

 over operating free-air temperature range (unless otherwise noted)⁽¹⁾

		MIN	MAX	UNIT
Supply Voltage Range ⁽²⁾	V _{CC}	-0.5	4	V
Voltage Range at any input or output terminal	Differential I/O	-0.5	1.5	V
	CMOS Inputs	-0.5	4	V
Junction temperature, T _J			105	°C
Storage temperature, T _{stg}		-65	150	°C

- (1) Stresses beyond those listed under *Absolute Maximum Ratings* may cause permanent damage to the device. These are stress ratings only, which do not imply functional operation of the device at these or any other conditions beyond those indicated under *Recommended Operating Conditions*. Exposure to absolute-maximum-rated conditions for extended periods may affect device reliability.
- (2) All voltage values are with respect to the GND terminals.

6.2 ESD Ratings

		VALUE	UNIT
V _(ESD) Electrostatic discharge	Human-body model (HBM), per ANSI/ESDA/JEDEC JS-001 ⁽¹⁾	±2000	V
	Charged-device model (CDM), per JEDEC specification JESD22-C101 ⁽²⁾	±500	

- (1) JEDEC document JEP155 states that 500-V HBM allows safe manufacturing with a standard ESD control process.
- (2) JEDEC document JEP157 states that 250-V CDM allows safe manufacturing with a standard ESD control process.

6.3 Recommended Operating Conditions

over operating free-air temperature range (unless otherwise noted)

		MIN	NOM	MAX	UNIT
V _{CC}	Main power supply	3	3.3	3.6	V
	Supply Ramp Requirement			100	ms
V _(PSN)	Supply Noise on V _{CC} Terminals			100	mV
T _A	Operating free-air temperature	TUSB522P	0	70	°C
		TUSB522PI	-40	85	°C
C _(AC)	AC coupling capacitor	75	100	200	nF

6.4 Thermal Information

THERMAL METRIC ⁽¹⁾		TUSB522P	UNIT
		RGE (VQFN)	
		24 PINS	
R _{θJA}	Junction-to-ambient thermal resistance	51.2	°C/W
R _{θJC(top)}	Junction-to-case (top) thermal resistance	55.9	°C/W
R _{θJB}	Junction-to-board thermal resistance	28.3	°C/W
ψ _{JT}	Junction-to-top characterization parameter	2.0	°C/W
ψ _{JB}	Junction-to-board characterization parameter	28.3	°C/W
R _{θJC(bot)}	Junction-to-case (bottom) thermal resistance	9.7	°C/W

(1) For more information about traditional and new thermal metrics, see the [Semiconductor and IC Package Thermal Metrics](#) application report.

6.5 Electrical Characteristics, Power Supply

over operating free-air temperature range (unless otherwise noted)

PARAMETER	TEST CONDITIONS	MIN	TYP	MAX	UNIT
I _{CC(ACTIVE)}	Average active current		98		mA
I _{CC(U2U3)}	Average current in U2/U3		1.2		mA
I _{CC(NC)}	Average current disconnect mode		265		μA
I _{CC(SHUTDOWN)}	Average shutdown current		60		μA

6.6 Electrical Characteristics, DC

over operating free-air temperature range (unless otherwise noted)

PARAMETER	TEST CONDITIONS	MIN	TYP	MAX	UNIT
3-State CMOS Inputs(EQ1/2, DE1/2)					
V _{IH}	High-level input voltage	V _{CC} × 0.8			V
V _{IM}	Mid-level input voltage		V _{CC} / 2.		V
V _{IL}	Low-level input voltage			V _{CC} × 0.2	V
V _F	Floating voltage	V _{IN} = High impedance	0.36 × V _{CC}		V
R _{PU}	Internal pull-up resistance		410		kΩ
R _{PD}	Internal pull-down resistance		240		kΩ
I _{IH}	High-level input current	V _{IN} = 3.6 V		26	μA
I _{IL}	Low-level input current	V _{IN} = GND, V _{CC} = 3.6.V	-26		μA
2-State CMOS Input (OS1/2, EN_RXD)					
V _{IH}	High-level input voltage	V _{CC} × 0.7			V
V _{IL}	Low-level input voltage			V _{CC} × 0.3	V
R _{PD}	Internal pull-down resistance		660		kΩ
I _{IH}	Low-level input current	V _{IN} = 3.6 V		25	μA
I _{IL}	Low-level input current	V _{IN} = GND, V _{CC} = 3.6.V	-10		μA

6.7 Electrical Characteristics, AC

over operating free-air temperature range (unless otherwise noted)

PARAMETER		TEST CONDITIONS	MIN	TYP	MAX	UNIT
Differential Receiver (RXP, RXN)						
$V_{(RX-DIFF-PP)}$	Input differential voltage swing.	AC-coupled differential peak-to-peak signal measured post CTLE through a reference channel	100		1200	mVpp
$V_{(RX-DC-CM)}$	Common-mode voltage bias in the receiver (DC)			0.7		V
$R_{(RX-DIFF-DC)}$	Differential input impedance (DC)	Present after a GEN1 device is detected on TXP/TXN	72		120	Ω
$R_{(RX-CM-DC)}$	Receiver DC Common Mode impedance		18		30	Ω
$Z_{(RX-HIGH-IMP-DC-POS)}$	Common-mode input impedance with termination disabled (DC)	Present when no GEN1 device is detected on TXP/TXN. Measured over the range of 0-500 mV with respect to GND.	25			k Ω
$V_{(RX-SIGNAL-DET-DIFF-PP)}$	Input Differential peak-to-peak Signal Detect Assert Level	At 5 Gbps, no input channel loss clock pattern		85		mV
$V_{(RX-IDLE-DET-DIFF-PP)}$	Input Differential peak-to-peak Signal Detect De-assert Level			85		mV
$V_{(RX-LFPS-DET-DIFF-PP)}$	Low Frequency Periodic Signaling (LFPS) Detect Threshold	Below the minimum is squelched.	100		300	mV
$V_{(RX-CM-AC-P)}$	Peak RX AC common mode voltage	Measured at package pin			150	mV
$V_{(detect)}$	Voltage change to allow receiver detect	Positive voltage to sense receiver termination			600	mV
$C_{(RX-PARASITIC)}$	Voltage change to allow receiver detect	At 2.5 GHz	0.17	0.63	0.99	pF
$R_{L(RX-DIFF)}$	Differential Return Loss	50 MHz – 1.25 GHz at 90 Ω		-19		dB
		2.5 GHz at 90 Ω		-14		dB
$R_{L(RX-CM)}$	Common Mode Return Loss	50 MHz – 1.25 GHz at 90 Ω		-13		dB
Differential Transmitter (TXP, TXN)						
$V_{(TX-DIFF-PP)}$	Transmitter differential voltage swing (transition-bit)	OS Low, 0dB DE	0.8	0.9		Vpp
		OS High, 0dB DE		1.1	1.2	Vpp
$V_{(TX-DIFF-PP-LFPS)}$	LFPS differential voltage swing	OS Low, High	0.8		1.2	Vpp
$V_{(TX-DE-RATIO)}$	Transmitter differential voltage De-Emphasis ratio	DE = Low		0		dB
		DE = Floating		-3.5		dB
		DE = High		-6.2		dB
$V_{(TX-RCV-DETECT)}$	Amount of voltage change allowed during Receiver Detection				600	mV
$V_{(TX-CM-IDLE-DELTA)}$	Transmitter idle common-mode voltage change while in U2/U3 and not actively transmitting LFPS		-600		600	mV
$V_{(TX-DC-CM)}$	Common-mode voltage bias in the transmitter (DC)			0.7		V
$V_{(TX-CM-AC-PP-ACTIVE)}$	Tx AC Common-mode voltage active	Max mismatch from Txp + Txn for both time and amplitude			100	mVpp
$V_{(TX-IDLE-DIFF-AC-PP)}$	AC Electrical idle differential peak-to-peak output voltage	At package pins	0		10	mV
$V_{(TX-IDLE-DIFF-DC)}$	DC Electrical idle differential output voltage	At package pins after low pass filter to remove AC component	0		10	mV
$V_{(TX-CM-DC-ACTIVE-IDLE-DELTA)}$	Absolute DC common mode voltage between U1 and U0	At package pin			200	mV
$C_{(TX)}$	TX input capacitance to GND	At 2.5 GHz			1.25	pF
$R_{(TX-DIFF)}$	Differential impedance of the driver		72		120	Ω
$R_{(TX-CM)}$	Common-mode impedance of the driver	Measured with respect to AC ground over 0-500 mV	18		30	Ω
$I_{(TX-SHORT)}$	TX short circuit current	TX \pm shorted to GND			60	mA
$C_{(TX-PARASITIC)}$	TX input capacitance for return loss	Package Pins		0.63	1.02	F
$R_{L(RX-DIFF)}$	Differential Return Loss	50 MHz – 1.25 GHz at 90 Ω		12		dB
		1.25 – 2.5 GHz at 90 Ω		8		dB

Electrical Characteristics, AC (continued)

over operating free-air temperature range (unless otherwise noted)

PARAMETER		TEST CONDITIONS	MIN	TYP	MAX	UNIT
$R_{L(RX-CM)}$	Common Mode Return Loss	50 MHz – 1.25 GHz at 90 Ω		13		dB
		1.25 – 2.5 GHz		11		dB
AC Characteristic						
Xtalk	Differential Cross Talk between TX and RX signal Pairs	At 2.5 GHz		–40		dB
$V_{(CM-TX-AC)}$	AC Common-mode voltage swing in active mode	Within U0 and within LFPS			100	mVpp
$V_{(TX-IDLE-DIFF-AC-PP)}$	Differential voltage swing during electrical idle	Tested with a high-pass filter	0		10	V
$R_{L(TX-DIFF)}$	Differential Return Loss	f = 50 MHz - 1.25 GHz		12		dB
		1.25 – 2.5 GHz		8		dB
$R_{L(TX-CM)}$	Common Mode Return Loss	f = 50 MHz - 1.25 GHz		16		dB
		1.25 – 2.5 GHz		13		dB
t_j	Total Jitter	Minimum input and output trace at 2.5 GHz, $V_{CC} = 3.3$ V		15		ps
$V_{(TX-CM-\Delta U1-U0)}$	Absolute delta of DC CM voltage during active and idle states				100	mV
$V_{(TX-IDLE-DIFF-DC)}$	DC Electrical idle differential output voltage	Voltage must be low pass filtered to remove any AC component	0		12	mV

7 Detailed Description

7.1 Overview

The TUSB522P is designed to overcome channel loss due to inter-symbol interference and crosstalk when 5 Gbps USB3.1 GEN1 signals travel across a PCB or cable. The dual channel architecture is a one-chip, low-power solution, extending the possible channel length for transmit and receive data paths in an application. For a Host application, this enables the system to pass both transmitter compliance and receiver jitter tolerance tests.

The re-driver recovers incoming data by applying equalization that compensates for channel loss, and drives out signals with a high differential voltage. Each channel has a receiver equalizer with selectable gain settings. The equalization should be set based on the amount of insertion loss in channel 1 or 2 before the TUSB522P receivers. Likewise, the output drivers support configuration of De-Emphasis. Independent equalization and de-emphasis control for each channel can be set using EQ1/2 and DE1/2 pins.

The TUSB522P advanced state machine makes it transparent to hosts and devices. After power up, the TUSB522P periodically performs receiver detection on the TX pairs. If it detects a USB3.1 GEN1 receiver, the RX termination is enabled, and the TUSB522P is ready to re-drive.

The device ultra-low-power architecture operates at a 3.3-V power supply and achieves Enhanced performance. The automatic LFPS De-Emphasis control further enables the system to be USB3.1 compliant.

7.2 Functional Block Diagram

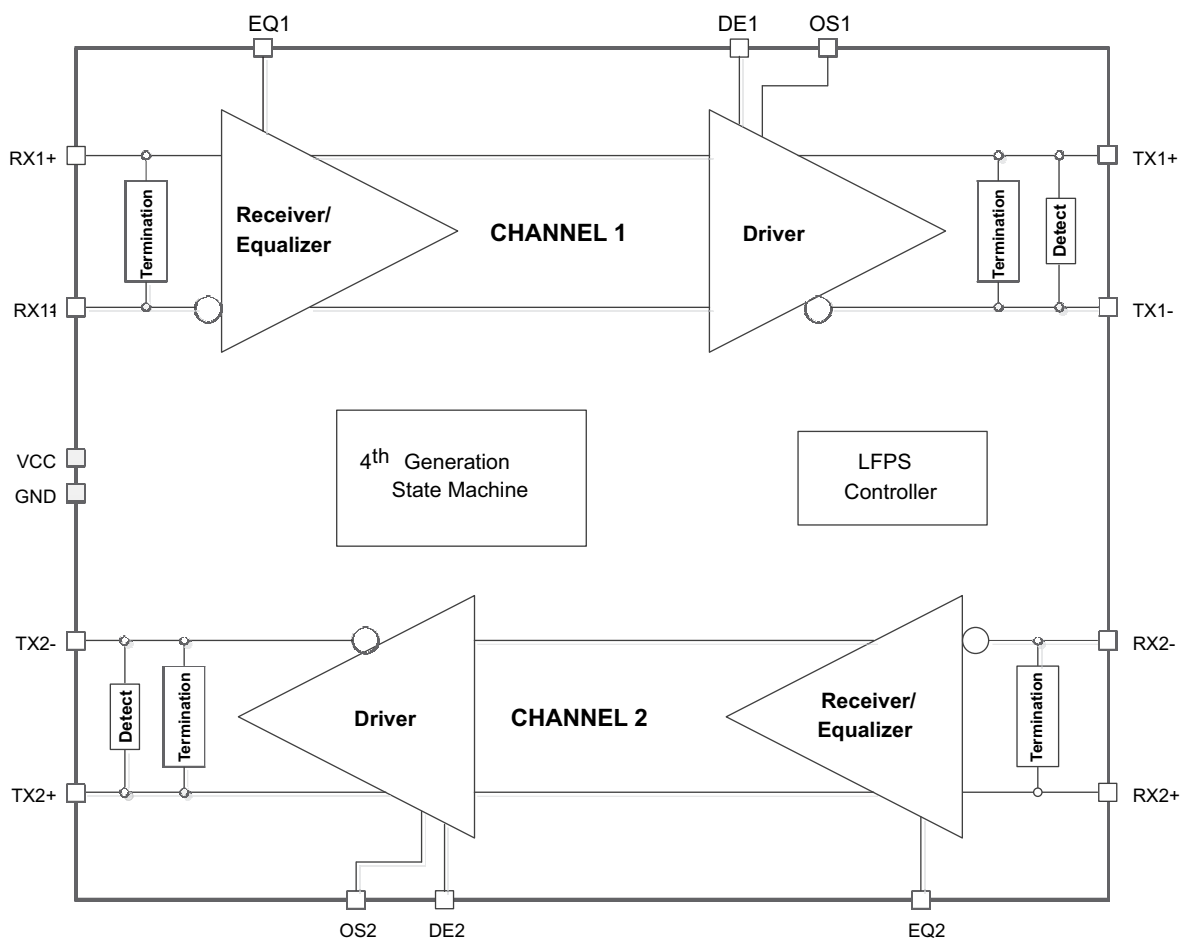

7.3 Feature Description

7.3.1 Receiver Equalization

The purpose of receiver equalization is to compensate for channel insertion loss and inter-symbol interference in the system before the input of the TUSB522P. The receiver overcomes these losses by attenuating the low frequency components of the signals with respect to the high frequency components. The proper gain setting should be selected to match the channel insertion loss before the input of the TUSB522P receivers. The gain setting may differ for channel 1 and channel 2.

7.3.2 De-Emphasis Control and Output Swing

The differential driver output provides selectable de-emphasis and output swing control in order to achieve USB3.1 compliance. The TUSB522P offers a unique way to adjust output de-emphasis and transmitter swing based on the OS1/2 and DE1/2 pins. The level of de-emphasis required in the system depends on the channel length after the output of the re-driver. The output swing and de-emphasis levels may differ for channel 1 and channel 2.

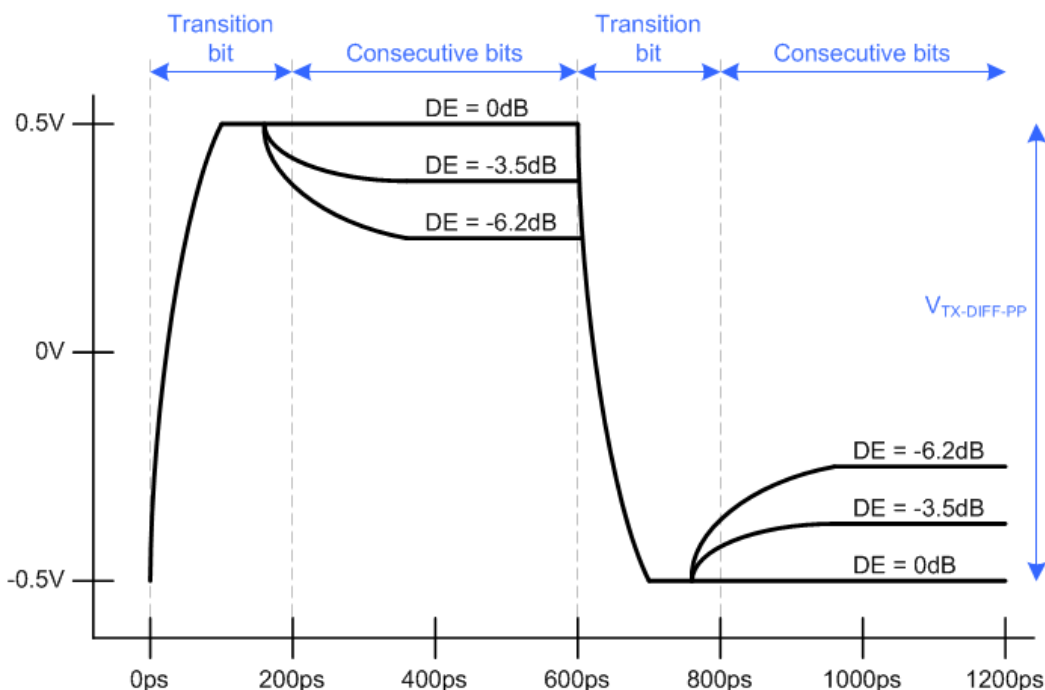

Figure 1. Transmitter Differential Voltage, OS = Floating

7.3.3 Automatic LFPS Detection

The TUSB522P features an intelligent low frequency periodic signaling (LFPS) controller. The controller senses the low frequency signals and automatically disables the driver de-emphasis, for full USB3.1 compliance.

7.4 Device Functional Modes

7.4.1 Device Configuration

Table 1. Control Pin Settings (Typical Values)

PIN	DESCRIPTION	LOGIC STATE	GAIN	
EQ1/EQ2	Equalization Amount	Low	3 dB	
		Floating	6 dB	
		High	9 dB	
PIN	DESCRIPTION	LOGIC STATE	OUTPUT DIFFERENTIAL VOLTAGE FOR THE TRANSITION BIT	
OS1/OS2	Output Swing Amplitude	LOW	0.9 V _{pp}	
		HIGH	1.1 V _{pp}	
PIN	DESCRIPTION	LOGIC STATE	DE-EMPHASIS RATIO	
			FOR OS = LOW	FOR OS = HIGH
DE1/DE2	De-Emphasis Amount	Low	0 dB	0 dB
		Floating	–3.5 dB	–3.5 dB
		High	–6.2 dB	–6.2 dB

7.4.2 Power Modes

The TUSB522P has 3 primary power modes:

7.4.2.1 U0 Mode (Active Power Mode)

During active power mode, U0, the device is transmitting USB SS data or USB LFPS signaling. The U0 mode is the highest power state of the TUSB522P. Anytime super-speed traffic is being received, the TUSB522P remains in this mode.

7.4.2.2 U2/U3 (Low Power Mode)

While in this mode, the TUSB522P periodically performs far-end receiver detection.

7.4.2.3 Disconnect Mode - RX Detect

In this state, the TUSB522P periodically checks for far-end receiver termination on both TX. Upon detection of the far-end receiver's termination on both ports, the TUSB522P will transition to U0 mode.

7.4.2.4 Shutdown Mode

Shutdown mode is entered when the EN_RXD pin is driven low. This is lowest power setting for the device.

8 Application and Implementation

NOTE

Information in the following applications sections is not part of the TI component specification, and TI does not warrant its accuracy or completeness. TI's customers are responsible for determining suitability of components for their purposes. Customers should validate and test their design implementation to confirm system functionality.

8.1 Application Information

The TUSB522P is a dual-channel single-lane re-driver and signal conditioner designed to compensate for ISI jitter caused by attenuation through passive mediums such as traces or cables. The TUSB522P has two independent channels to allow optimization in both upstream and downstream directions through three EQ and six De-Emphasis settings.

8.2 Typical Application

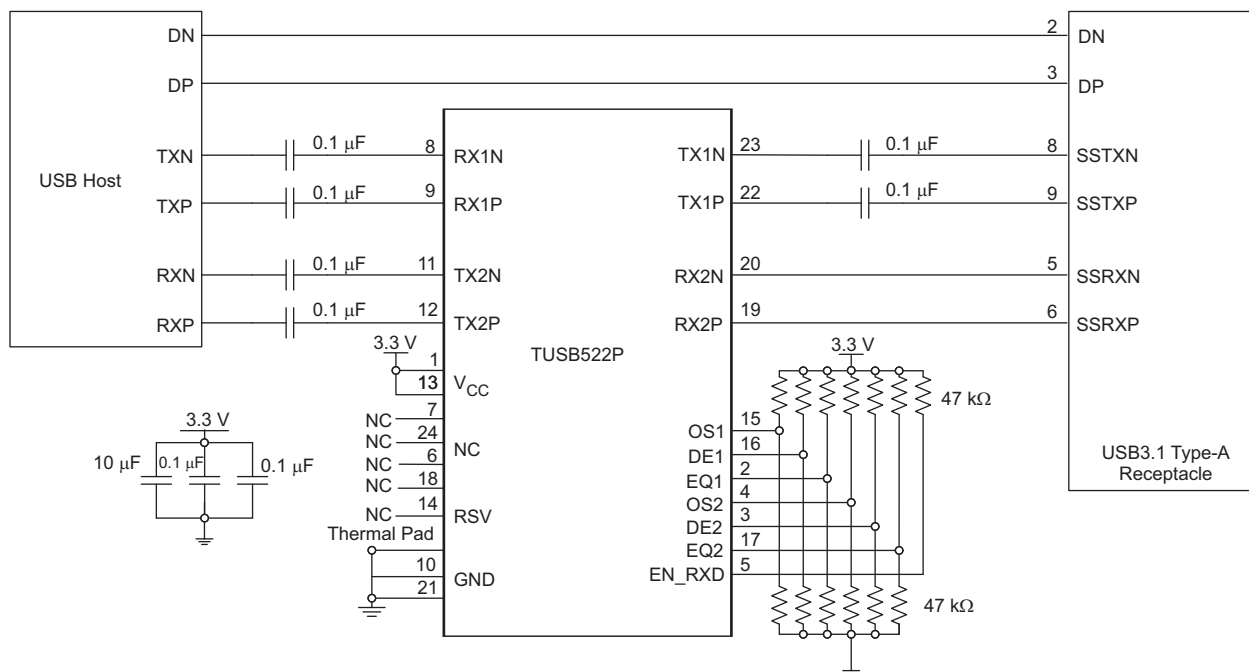

Figure 2. Embedded Host Application

Typical Application (continued)

8.2.1 Design Requirements

For this design example, use the parameters shown in [Table 2](#).

Table 2. Design Parameters

PARAMETERS	VALUE
V _{CC} Supply (3 V – 3.6 V)	3.3 V
AC Coupling Capacitor (75nF to 265nF)	100 nF
Host to TUSB522P FR4 Length (Inches)	20
Host to TUSB522P FR4 Trace Width (mils)	4
TUSB522P to Connector FR4 Length (Inches)	6
TUSB522P to Connector FR4 Trace Width (mils)	4
EQ1 (RX1P/RX1N)	9 dB (EQ1 = High)
De-Emphasis 2 (TX2P/TX2N)	-6.2 dB (OS2 = Low, DE2 = High)
EQ2 (RX2P/RX2N)	6 dB (EQ2 = Floating)
De-Emphasis 1 (TX1P/TX1N)	-3.5 dB (OS1 = Low, DE1 = Floating)
Output Swing 1 (OS1)	900 mV (OS1 = Low)
Output Swing 2 (OS2)	900 mV (OS2 = Low)

8.2.2 Detailed Design Procedure

The TUSB522P differential receivers and transmitters have internal BIAS and termination. Due to this, the TUSB522P must be connected to the USB Host and receptacle through ac-coupling capacitors. In this example, as depicted in [Table 1](#), 100 nF capacitors are placed on TX2P, TX2N, RX1P, RX1N, TX1P and TX1N. No ac-coupling capacitors are placed on the RX2P and RX2N pins because it is assumed the device downstream of the TUSB522P will have ac-coupling capacitors on its transmitter as defined by the USB 3.1 specification.

8.2.3 Application Curves

BERT > 24"6mil > char-board > RX2-to-TX2 > char-board > Scope

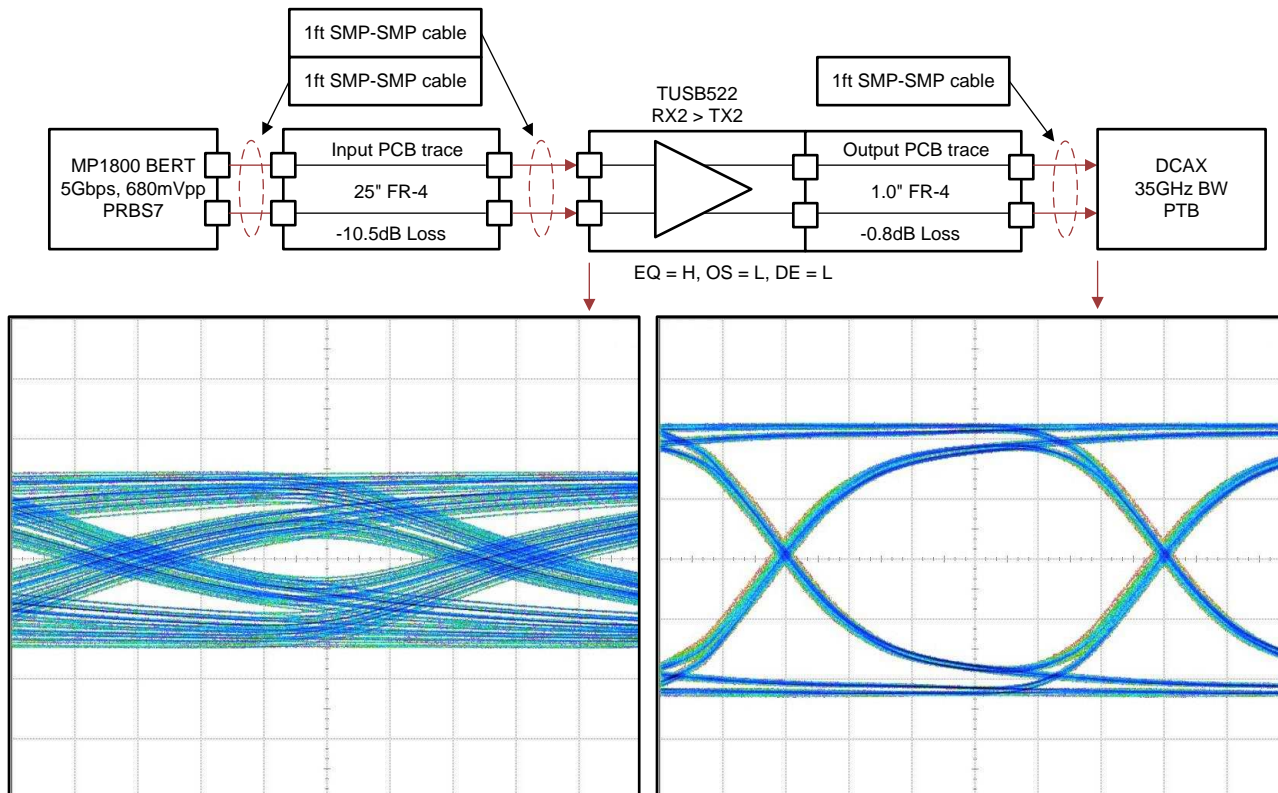

9 Power Supply Recommendations

The TUSB522P is designed to operate with a 3.3-V power supply. Levels above those listed in the Absolute Ratings table should not be used. If using a higher voltage system power supply, a voltage regulator can be used to step down to 3.3 V. Decoupling capacitors should be used to reduce noise and improve power supply integrity. A 0.1- μ F capacitor should be used on each power pin.

10 Layout

10.1 Layout Guidelines

- RXP/N and TXP/N pairs should be routed with controlled 90-Ω differential impedance ($\pm 15\%$).
- Keep away from other high speed signals.
- Intra-pair routing should be kept to within 2mils.
- Length matching should be near the location of mismatch.
- Each pair should be separated at least by 3 times the signal trace width.
- The use of bends in differential traces should be kept to a minimum. When bends are used, the number of left and right bends should be as equal as possible and the angle of the bend should be ≥ 135 degrees. This will minimize any length mismatch causes by the bends and therefore minimize the impact bends have on EMI.
- Route all differential pairs on the same of layer.
- The number of VIAS should be kept to a minimum. It is recommended to keep the VIAS count to 2 or less.
- Keep traces on layers adjacent to ground plane.
- Do NOT route differential pairs over any plane split.
- Adding Test points will cause impedance discontinuity; and will therefore, negatively impact signal performance. If test points are used, they should be placed in series and symmetrically. They must not be placed in a manner that causes a stub on the differential pair.
- The 100-nF capacitors on the TXP and SSTXN nets must be placed close to the USB connector (Type A, Type B, and so forth).
- The ESD and EMI protection devices (if used) must also be placed as close as possible to the USB connector.
- Place voltage regulators as far away as possible from the differential pairs.
- In order to minimize crosstalk, TI recommends keeping high-speed signals away from each other. Each pair must be separated by at least 5 times the signal trace width. Separating with ground also helps minimize crosstalk.

10.2 Layout Example

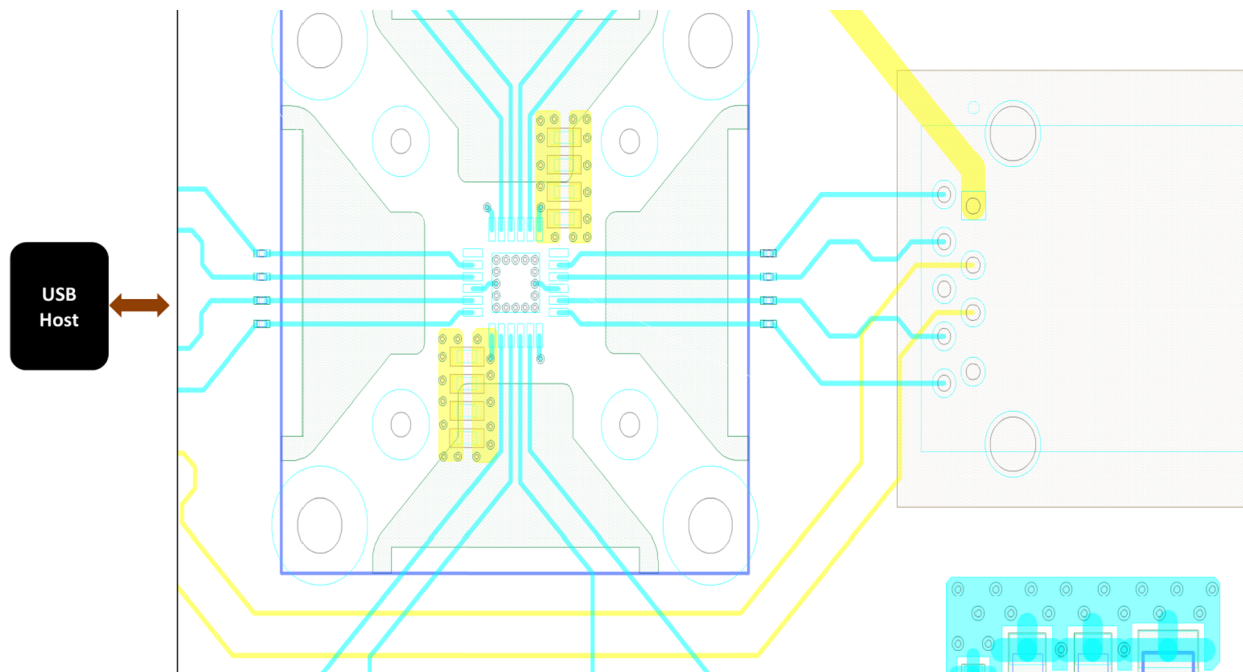

Figure 3. Example Layout

11 Device and Documentation Support

11.1 Documentation Support

11.1.1 Related Documentation

For related documentation see the following

11.2 Related Links

The table below lists quick access links. Categories include technical documents, support and community resources, tools and software, and quick access to sample or buy.

11.3 Receiving Notification of Documentation Updates

To receive notification of documentation updates, navigate to the device product folder on ti.com. In the upper right corner, click on *Alert me* to register and receive a weekly digest of any product information that has changed. For change details, review the revision history included in any revised document.

11.4 Community Resources

The following links connect to TI community resources. Linked contents are provided "AS IS" by the respective contributors. They do not constitute TI specifications and do not necessarily reflect TI's views; see TI's [Terms of Use](#).

TI E2E™ Online Community *TI's Engineer-to-Engineer (E2E) Community*. Created to foster collaboration among engineers. At e2e.ti.com, you can ask questions, share knowledge, explore ideas and help solve problems with fellow engineers.

Design Support *TI's Design Support* Quickly find helpful E2E forums along with design support tools and contact information for technical support.

11.5 Trademarks

E2E is a trademark of Texas Instruments.
All other trademarks are the property of their respective owners.

11.6 Electrostatic Discharge Caution



This integrated circuit can be damaged by ESD. Texas Instruments recommends that all integrated circuits be handled with appropriate precautions. Failure to observe proper handling and installation procedures can cause damage.

ESD damage can range from subtle performance degradation to complete device failure. Precision integrated circuits may be more susceptible to damage because very small parametric changes could cause the device not to meet its published specifications.

11.7 Glossary

SLYZ022 — *TI Glossary*.

This glossary lists and explains terms, acronyms, and definitions.

12 Mechanical, Packaging, and Orderable Information

The following pages include mechanical, packaging, and orderable information. This information is the most current data available for the designated devices. This data is subject to change without notice and revision of this document. For browser-based versions of this data sheet, refer to the left-hand navigation.

PACKAGING INFORMATION

Orderable Device	Status (1)	Package Type	Package Drawing	Pins	Package Qty	Eco Plan (2)	Lead/Ball Finish (6)	MSL Peak Temp (3)	Op Temp (°C)	Device Marking (4/5)	Samples
TUSB522PIRGER	ACTIVE	VQFN	RGE	24	3000	Green (RoHS & no Sb/Br)	CU NIPDAU	Level-2-260C-1 YEAR	-40 to 85	TUSB522P	Samples
TUSB522PIRGET	ACTIVE	VQFN	RGE	24	250	Green (RoHS & no Sb/Br)	CU NIPDAU	Level-2-260C-1 YEAR	-40 to 85	TUSB522P	Samples
TUSB522PRGER	ACTIVE	VQFN	RGE	24	3000	Green (RoHS & no Sb/Br)	CU NIPDAU	Level-2-260C-1 YEAR	0 to 70	TUSB522P	Samples
TUSB522PRGET	ACTIVE	VQFN	RGE	24	250	Green (RoHS & no Sb/Br)	CU NIPDAU	Level-2-260C-1 YEAR	0 to 70	TUSB522P	Samples

(1) The marketing status values are defined as follows:

ACTIVE: Product device recommended for new designs.

LIFEBUY: TI has announced that the device will be discontinued, and a lifetime-buy period is in effect.

NRND: Not recommended for new designs. Device is in production to support existing customers, but TI does not recommend using this part in a new design.

PREVIEW: Device has been announced but is not in production. Samples may or may not be available.

OBSELETE: TI has discontinued the production of the device.

(2) **RoHS:** TI defines "RoHS" to mean semiconductor products that are compliant with the current EU RoHS requirements for all 10 RoHS substances, including the requirement that RoHS substance do not exceed 0.1% by weight in homogeneous materials. Where designed to be soldered at high temperatures, "RoHS" products are suitable for use in specified lead-free processes. TI may reference these types of products as "Pb-Free".

RoHS Exempt: TI defines "RoHS Exempt" to mean products that contain lead but are compliant with EU RoHS pursuant to a specific EU RoHS exemption.

Green: TI defines "Green" to mean the content of Chlorine (Cl) and Bromine (Br) based flame retardants meet JS709B low halogen requirements of <=1000ppm threshold. Antimony trioxide based flame retardants must also meet the <=1000ppm threshold requirement.

(3) MSL, Peak Temp. - The Moisture Sensitivity Level rating according to the JEDEC industry standard classifications, and peak solder temperature.

(4) There may be additional marking, which relates to the logo, the lot trace code information, or the environmental category on the device.

(5) Multiple Device Markings will be inside parentheses. Only one Device Marking contained in parentheses and separated by a "-" will appear on a device. If a line is indented then it is a continuation of the previous line and the two combined represent the entire Device Marking for that device.

(6) Lead/Ball Finish - Orderable Devices may have multiple material finish options. Finish options are separated by a vertical ruled line. Lead/Ball Finish values may wrap to two lines if the finish value exceeds the maximum column width.

Important Information and Disclaimer:The information provided on this page represents TI's knowledge and belief as of the date that it is provided. TI bases its knowledge and belief on information provided by third parties, and makes no representation or warranty as to the accuracy of such information. Efforts are underway to better integrate information from third parties. TI has taken and

continues to take reasonable steps to provide representative and accurate information but may not have conducted destructive testing or chemical analysis on incoming materials and chemicals. TI and TI suppliers consider certain information to be proprietary, and thus CAS numbers and other limited information may not be available for release.

In no event shall TI's liability arising out of such information exceed the total purchase price of the TI part(s) at issue in this document sold by TI to Customer on an annual basis.

TAPE AND REEL INFORMATION

QUADRANT ASSIGNMENTS FOR PIN 1 ORIENTATION IN TAPE

*All dimensions are nominal

Device	Package Type	Package Drawing	Pins	SPQ	Reel Diameter (mm)	Reel Width W1 (mm)	A0 (mm)	B0 (mm)	K0 (mm)	P1 (mm)	W (mm)	Pin1 Quadrant
TUSB522PIRGER	VQFN	RGE	24	3000	330.0	12.4	4.25	4.25	1.15	8.0	12.0	Q2
TUSB522PIRGET	VQFN	RGE	24	250	180.0	12.4	4.25	4.25	1.15	8.0	12.0	Q2
TUSB522PRGER	VQFN	RGE	24	3000	330.0	12.4	4.25	4.25	1.15	8.0	12.0	Q2
TUSB522PRGET	VQFN	RGE	24	250	180.0	12.4	4.25	4.25	1.15	8.0	12.0	Q2

TAPE AND REEL BOX DIMENSIONS

*All dimensions are nominal

Device	Package Type	Package Drawing	Pins	SPQ	Length (mm)	Width (mm)	Height (mm)
TUSB522PIRGER	VQFN	RGE	24	3000	367.0	367.0	35.0
TUSB522PIRGET	VQFN	RGE	24	250	210.0	185.0	35.0
TUSB522PRGER	VQFN	RGE	24	3000	367.0	367.0	35.0
TUSB522PRGET	VQFN	RGE	24	250	210.0	185.0	35.0

RGE 24

GENERIC PACKAGE VIEW

VQFN - 1 mm max height

PLASTIC QUAD FLATPACK - NO LEAD

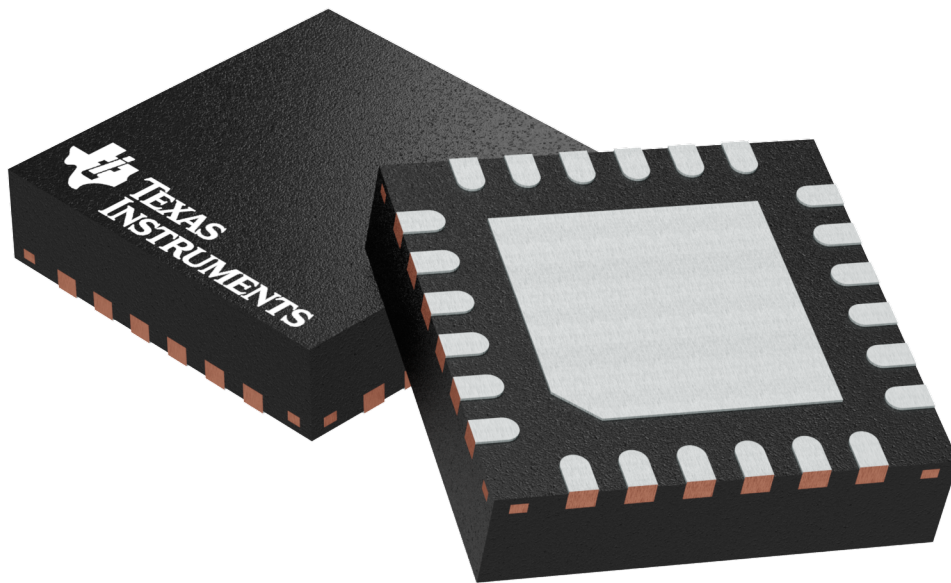

Images above are just a representation of the package family, actual package may vary.
Refer to the product data sheet for package details.

4204104/H

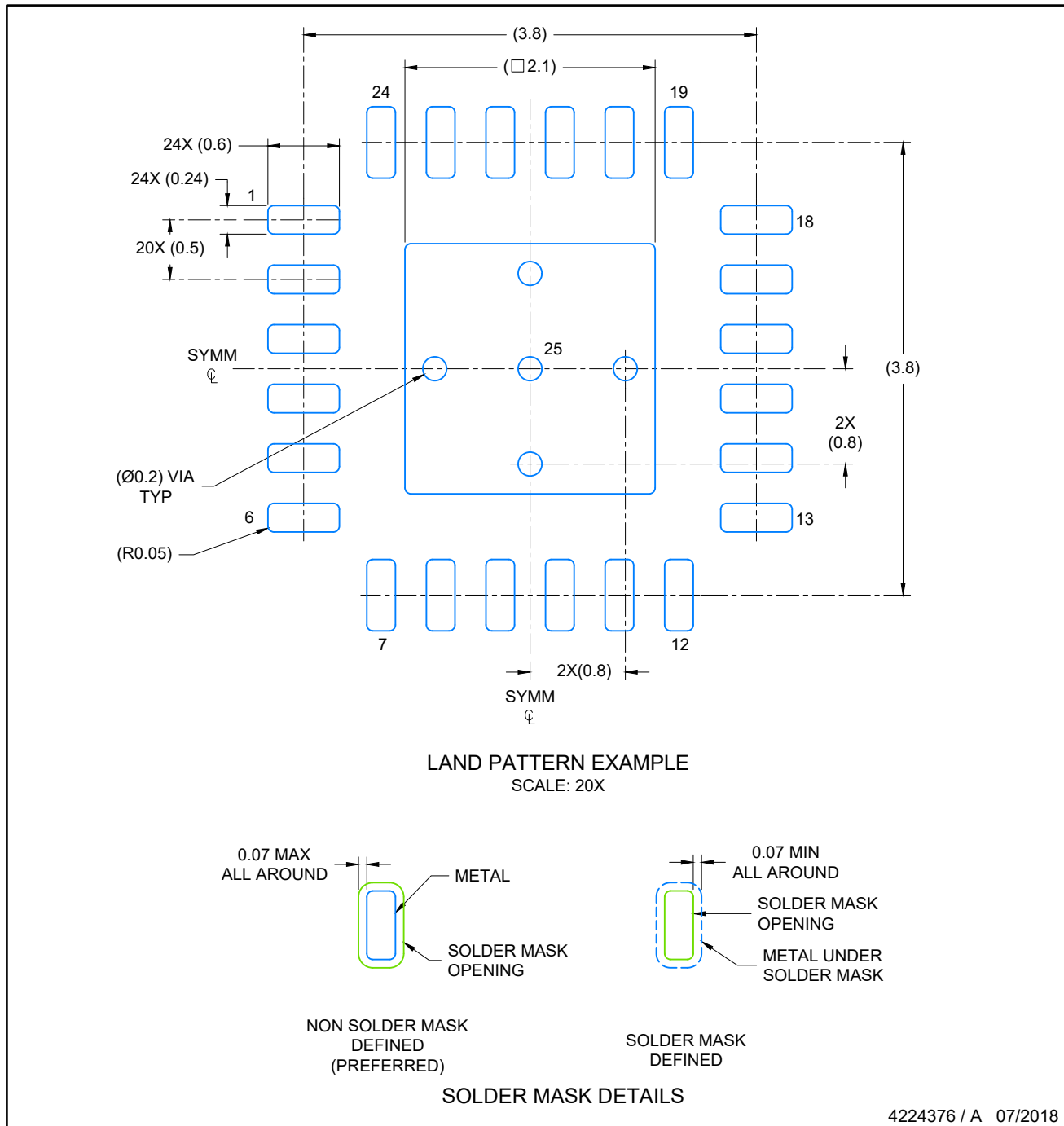

NOTES: (continued)

4. This package is designed to be soldered to a thermal pad on the board. For more information, see Texas Instruments literature number SLUA271 (www.ti.com/lit/slua271).
5. Solder mask tolerances between and around signal pads can vary based on board fabrication site.

EXAMPLE STENCIL DESIGN

VQFN - 1 mm max height

RGE0024C

PLASTIC QUAD FLATPACK- NO LEAD

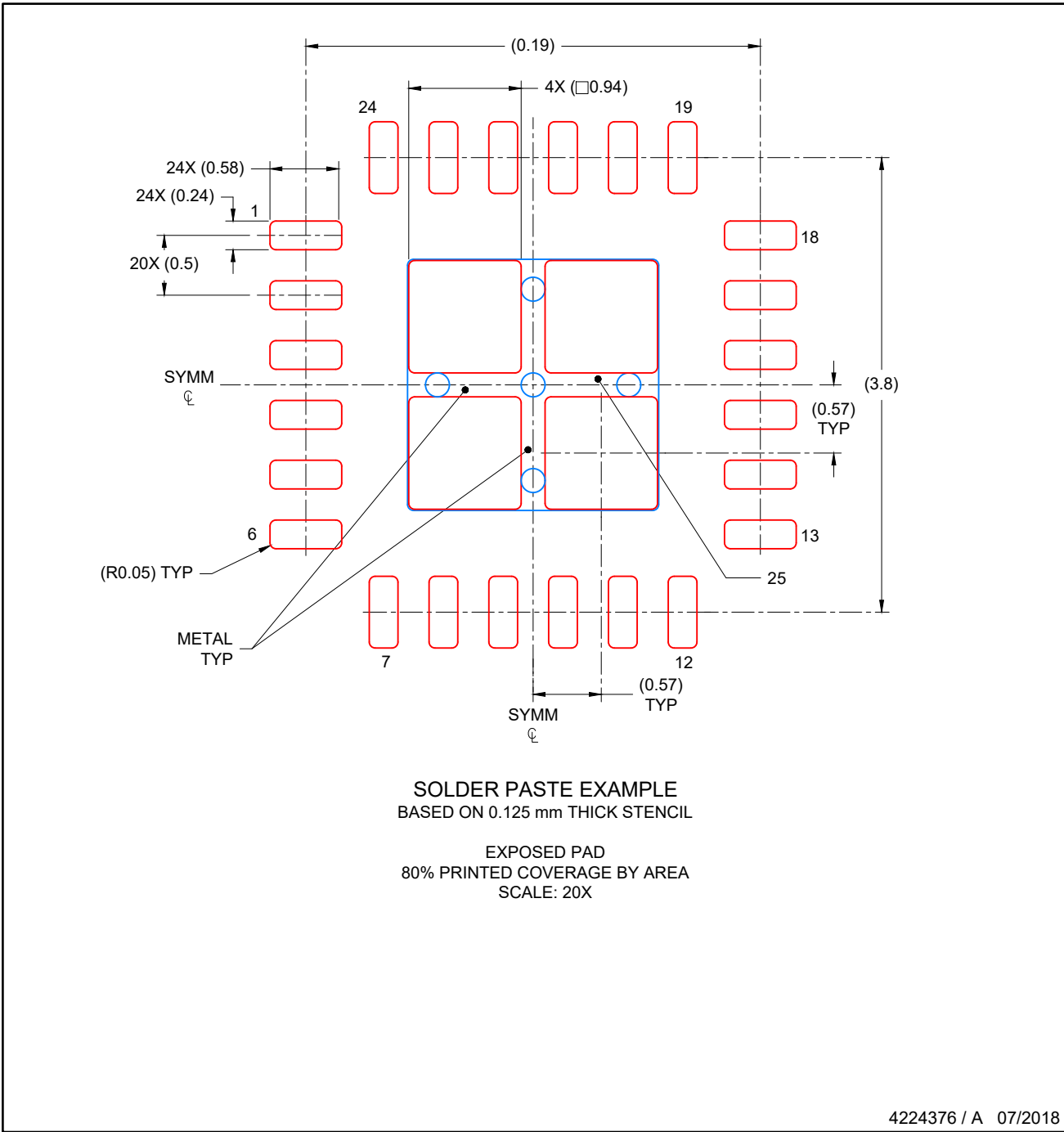

NOTES: (continued)

- 6. Laser cutting apertures with trapezoidal walls and rounded corners may offer better paste release. IPC-7525 may have alternate design recommendations..

IMPORTANT NOTICE AND DISCLAIMER

TI PROVIDES TECHNICAL AND RELIABILITY DATA (INCLUDING DATASHEETS), DESIGN RESOURCES (INCLUDING REFERENCE DESIGNS), APPLICATION OR OTHER DESIGN ADVICE, WEB TOOLS, SAFETY INFORMATION, AND OTHER RESOURCES "AS IS" AND WITH ALL FAULTS, AND DISCLAIMS ALL WARRANTIES, EXPRESS AND IMPLIED, INCLUDING WITHOUT LIMITATION ANY IMPLIED WARRANTIES OF MERCHANTABILITY, FITNESS FOR A PARTICULAR PURPOSE OR NON-INFRINGEMENT OF THIRD PARTY INTELLECTUAL PROPERTY RIGHTS.

These resources are intended for skilled developers designing with TI products. You are solely responsible for (1) selecting the appropriate TI products for your application, (2) designing, validating and testing your application, and (3) ensuring your application meets applicable standards, and any other safety, security, or other requirements. These resources are subject to change without notice. TI grants you permission to use these resources only for development of an application that uses the TI products described in the resource. Other reproduction and display of these resources is prohibited. No license is granted to any other TI intellectual property right or to any third party intellectual property right. TI disclaims responsibility for, and you will fully indemnify TI and its representatives against, any claims, damages, costs, losses, and liabilities arising out of your use of these resources.

TI's products are provided subject to TI's Terms of Sale (www.ti.com/legal/termsofsale.html) or other applicable terms available either on ti.com or provided in conjunction with such TI products. TI's provision of these resources does not expand or otherwise alter TI's applicable warranties or warranty disclaimers for TI products.

Mailing Address: Texas Instruments, Post Office Box 655303, Dallas, Texas 75265
Copyright © 2019, Texas Instruments Incorporated

Looking for pricing, stock, or lifecycle information?

Click below to explore more details on WIN SOURCE:

 [View TUSB522PIRGET](#) on WIN SOURCE

 [Texas Instruments](#) Information

Optimize Your Supply Chain with WIN SOURCE Solutions

-  Global Sourcing Solution
-  Obsolete Management
-  Cost Control Management
-  Shortage Management
-  Alternative Solution
-  Excess Inventory Management