



**THE DATASHEET OF  
BQ27621YZFT-G1A**



## bq27621-G1 System-Side Fuel Gauge With Dynamic Voltage Correlation

### 1 Features

- Single-Cell Li-Ion Battery Fuel Gauge
  - Resides on System Board
  - Supports Embedded or Removable Batteries
  - Powered Directly from Battery with Integrated LDO
- Easy To Configure Fuel Gauging Based on the Dynamic Voltage Correlation Algorithm
  - Reports Remaining Capacity and State of Charge (SOC) with Smoothing Filter
  - Automatically Adjusts for Self-Discharge, Temperature, and Rate Changes
- Microcontroller Peripheral Supports:
  - 400-kHz I<sup>2</sup>C Serial Interface
  - Configurable SOC Interrupt or Battery Low Digital Output Warning
  - Internal Temperature Sensor or Host Reported Temperature
- Support 4.2-V, 4.3-V, and 4.35-V Chemistries
- 9-pin 1.62 × 1.58 mm, 0.5 mm pitch YZF package

### 2 Applications

- Smartphones, Feature Phones, and Tablets
- Digital Still and Video Cameras
- Handheld Terminals
- MP3 or Multimedia Players

### 3 Description

The Texas Instruments bq27621-G1 is a minimally configured microcontroller peripheral that provides system-side fuel gauging for single-cell Li-Ion batteries. The device requires very little user configuration and system microcontroller firmware development.

The bq27621-G1 uses the Dynamic Voltage Correlation algorithm for fuel gauging. This process eliminates the need for a sense resistor when calculating remaining battery capacity (mAh), state-of-charge (%), battery voltage (mV), and temperature (°C).

Battery fuel gauging with the bq27621-G1 requires connections only to PACK+ (P+) and PACK– (P–) for a removable battery pack or embedded battery circuit. The tiny 9-pin, 1.62 mm × 1.58 mm, 0.5 mm pitch YZF package is ideal for space-constrained applications.

#### Device Information<sup>(1)</sup>

PART NUMBER	PACKAGE	BODY SIZE (NOM)
BQ27621-G1	YZF (9)	1.62 mm × 1.58 mm

(1) For all available packages, see the orderable addendum at the end of the datasheet.

#### Simplified Schematic

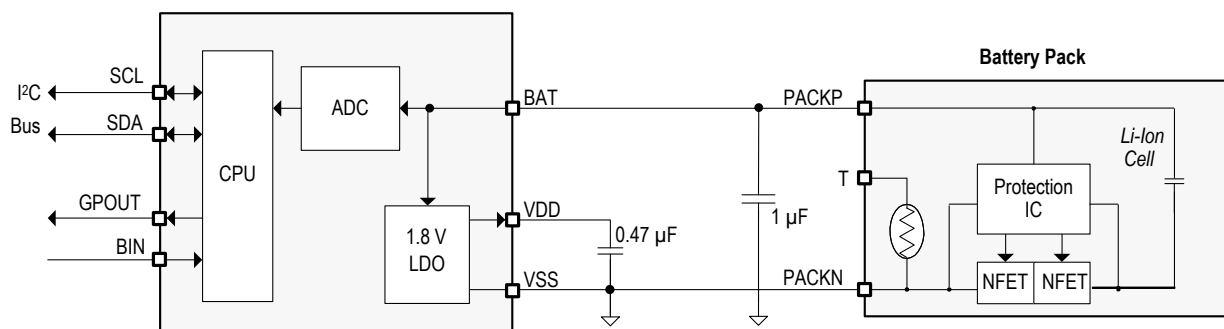

## Table of Contents

<b>1 Features</b> .....	<b>1</b>	8.1 Overview .....	<b>8</b>
<b>2 Applications</b> .....	<b>1</b>	8.2 Functional Block Diagram .....	<b>8</b>
<b>3 Description</b> .....	<b>1</b>	8.3 Feature Description .....	<b>9</b>
<b>4 Revision History</b> .....	<b>2</b>	8.4 Device Functional Modes .....	<b>9</b>
<b>5 Device Comparison Table</b> .....	<b>3</b>	8.5 Programming .....	<b>9</b>
<b>6 Pin Configurations and Functions</b> .....	<b>3</b>	<b>9 Application and Implementation</b> .....	<b>14</b>
<b>7 Specifications</b> .....	<b>4</b>	9.1 Application Information .....	<b>14</b>
7.1 Absolute Maximum Ratings .....	<b>4</b>	9.2 Typical Application .....	<b>14</b>
7.2 ESD Ratings .....	<b>4</b>	<b>10 Power Supply Recommendations</b> .....	<b>16</b>
7.3 Recommended Operating Conditions .....	<b>4</b>	10.1 Power Supply Decoupling .....	<b>16</b>
7.4 Thermal Information .....	<b>4</b>	<b>11 Layout</b> .....	<b>17</b>
7.5 Supply Current .....	<b>4</b>	11.1 Layout Guidelines .....	<b>17</b>
7.6 Digital Input and Output DC Characteristics .....	<b>5</b>	11.2 Layout Example .....	<b>17</b>
7.7 LDO Regulator, Wake-up, and Auto-Shutdown DC Characteristics .....	<b>5</b>	<b>12 Device and Documentation Support</b> .....	<b>18</b>
7.8 ADC (Temperature and Cell Measurement) Characteristics .....	<b>5</b>	12.1 Documentation Support .....	<b>18</b>
7.9 I <sup>2</sup> C-Compatible Interface Communication Timing Characteristics .....	<b>5</b>	12.2 Community Resources .....	<b>18</b>
7.10 Typical Characteristics .....	<b>7</b>	12.3 Trademarks .....	<b>18</b>
<b>8 Detailed Description</b> .....	<b>8</b>	12.4 Electrostatic Discharge Caution .....	<b>18</b>
		12.5 Glossary .....	<b>18</b>
		<b>13 Mechanical, Packaging, and Orderable Information</b> .....	<b>18</b>

## 4 Revision History

Changes from Revision D (December 2014) to Revision E	Page
• Changed <a href="#">Pin Configurations and Functions</a> .....	<b>3</b>
• Added <a href="#">Community Resources</a> .....	<b>18</b>
• Changed <a href="#">Mechanical, Packaging, and Orderable Information</a> .....	<b>18</b>

Changes from Revision C (March 2014) to Revision D	Page
• Added <i>ESD Ratings</i> table, <i>Feature Description</i> section, <i>Device Functional Modes</i> , <i>Application and Implementation</i> section, <i>Power Supply Recommendations</i> section, <i>Layout</i> section, <i>Device and Documentation Support</i> section, and <i>Mechanical, Packaging, and Orderable Information</i> section .....	<b>1</b>
• Changed Typical Application to Simplified Schematic and added 1- $\mu$ F capacitor .....	<b>1</b>
• Added description for connecting 1- $\mu$ F capacitor .....	<b>3</b>
• Added information for connecting GPOUT .....	<b>3</b>

Changes from Revision B (January 2014) to Revision C	Page
• Updated command list and algorithm descriptions .....	<b>1</b>
• Updated BIN pin description .....	<b>3</b>
• Updated GPOUT pin description .....	<b>3</b>
• Changed recommend to required .....	<b>17</b>

## 5 Device Comparison Table

PART NUMBER	BATTERY TYPE	CHEM_ID <sup>(1)</sup>	FIRMWARE VERSION <sup>(2)</sup>	PACKAGE <sup>(3)</sup>	COMMUNICATION FORMAT
bq27621YZFR-G1	LiCoO <sub>2</sub> (4.2 V maximum charge)	0x1202	1.05 (0x0105)	CSP-9	I <sup>2</sup> C
	LiCoO <sub>2</sub> (4.3 V maximum charge)	0x1210			
	LiCoO <sub>2</sub> (4.35 V maximum charge)	0x354			

- (1) See the CHEM\_ID subcommand to confirm the battery chemistry type. See [Alternate Chemistry Selection](#) to select different chemistries.  
 (2) See the FW\_VERSION subcommand to confirm the firmware version.  
 (3) For the most current package and ordering information see the Package Option Addendum at the end of this document; or, see the TI website at [www.ti.com](http://www.ti.com).

## 6 Pin Configurations and Functions

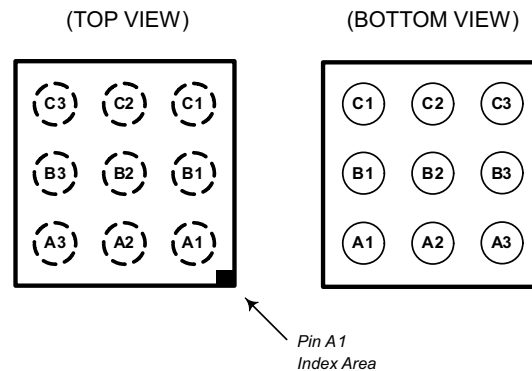

### Pin Functions

PIN		TYPE <sup>(1)</sup>	DESCRIPTION
NAME	NO.		
BAT	C2, C3	PI, AI	LDO regulator input and battery voltage input. Connect to positive battery connector. For highest accuracy, use a Kelvin connection by directly routing to the PACK+ pin and minimizing current flow through the trace. Connect a capacitor (1 μF) between BAT and V <sub>SS</sub> . Place the capacitor close to gauge.
BIN	B1	DI	Battery insertion detection input. If <b>Operation Configuration</b> bit <b>[BIE]</b> = 1 (default), a logic low on the pin is detected as battery insertion. For a removable pack, the BIN pin can be connected to V <sub>SS</sub> through a pull-down resistor on the pack, typically the 10-kΩ thermistor; the system board should use a 1.8-MΩ pullup resistor to V <sub>DD</sub> to ensure the BIN pin is high when a battery is removed. If the battery is embedded in the system, it is recommended to leave <b>[BIE]</b> = 1 and use a 10-kΩ pull-down resistor from BIN to V <sub>SS</sub> . If <b>[BIE]</b> = 0, then the host must inform the gauge of battery insertion and removal with the <b>BAT_INSERT</b> and <b>BAT_REMOVE</b> subcommands. A 10-kΩ pull-down resistor should be placed between BIN and V <sub>SS</sub> , even if this pin is unused. <b>NOTE:</b> The BIN pin must not be shorted directly to V <sub>CC</sub> or V <sub>SS</sub> and any pullup resistor on the BIN pin must be connected only to the bq27621 V <sub>DD</sub> and not an external voltage rail.
GPOUT	A1	DO	This open-drain output can be configured to indicate BAT_LOW when the <b>Operation Configuration [BATLOWEN]</b> bit is set. By default <b>[BATLOWEN]</b> is cleared and this pin performs an interrupt function (SOC_INT) by pulsing for specific events, such as a change in State of Charge. Signal polarity for these functions is controlled by the <b>[GPIOPOL]</b> configuration bit. This pin should not be left floating, even if unused, so a 10-kΩ pullup resistor is recommended. If the device is in shutdown mode, then toggling GPOUT will make the gauge exit shutdown. Therefore, it is recommended to connect GPOUT to a GPIO of the host MSU.
SCL	A3	DIO	Slave I <sup>2</sup> C serial communications clock input line for communication with system (Master). Use with 10-kΩ pullup resistor (typical).
SDA	A2	DIO	Slave I <sup>2</sup> C serial communications data line for communication with system (Master). Open-drain I/O. Use with 10-kΩ pullup resistor (typical).
VDD	B3	PO	1.8-V Regulator Output. Decouple with 0.47-μF ceramic capacitor to V <sub>SS</sub> .
VSS	B2, C1	PI	Ground pins. B2 is the actual device ground pin while C1 is floating internally. Therefore, C1 may be used as a bridge to connect to the board ground plane without requiring a via under the device package. Recommend routing B2 to C1 using a top-layer metal trace on the board. Connect to negative battery connector. For highest accuracy, use a Kelvin connection by directly routing to the PACK- pin and minimizing current flow through the trace.

- (1) IO = Digital input-output, IA = Analog input, P = Power connection

## 7 Specifications

### 7.1 Absolute Maximum Ratings

over operating free-air temperature range (unless otherwise noted)<sup>(1)</sup>

PARAMETER		MIN	MAX	UNIT
V <sub>BAT</sub>	BAT pin input voltage range	-0.3	6	V
V <sub>DD</sub>	V <sub>DD</sub> pin supply voltage range (LDO output)	-0.3	2	V
V <sub>IOD</sub>	Open-drain I/O pins (SDA, SCL, GPOUT)	-0.3	6	V
V <sub>IOPP</sub>	Push-Pull I/O pins (BIN)	-0.3	[V <sub>DD</sub> + 0.3]	V
T <sub>A</sub>	Operating free-air temperature range	-40	85	°C
T <sub>stg</sub>	Storage temperature	-65	150	°C

- (1) Stresses beyond those listed under "absolute maximum ratings" may cause permanent damage to the device. These are stress ratings only, and functional operation of the device at these or any other conditions beyond those indicated under "recommended operating conditions" is not implied. Exposure to absolute-maximum-rated conditions for extended periods may affect device reliability.

### 7.2 ESD Ratings

		VALUE	UNIT
V <sub>(ESD)</sub>	Electrostatic discharge	Human-body model (HBM), per ANSI/ESDA/JEDEC JS-001 <sup>(1)</sup>	V
		Charged-device model (CDM), per JEDEC specification JESD22-C101 <sup>(2)</sup>	
		±1000	
		±250	

- (1) JEDEC document JEP155 states that 500-V HBM allows safe manufacturing with a standard ESD control process.  
 (2) JEDEC document JEP157 states that 250-V CDM allows safe manufacturing with a standard ESD control process.

### 7.3 Recommended Operating Conditions

T<sub>A</sub> = 30°C and V<sub>REGIN</sub> = V<sub>BAT</sub> = 3.6 V (unless otherwise noted)

PARAMETER		TEST CONDITIONS	MIN	NOM	MAX	UNIT
C <sub>BAT</sub> <sup>(1)</sup>	Optional external input capacitor for internal LDO between BAT and V <sub>SS</sub>	Nominal capacitor values specified. Recommend a 5% ceramic X5R type capacitor located close to the device.		0.1		µF
C <sub>LDO18</sub> <sup>(1)</sup>	External output capacitor for internal LDO between V <sub>DD</sub> and V <sub>SS</sub>			0.47		µF
V <sub>PU</sub> <sup>(1)</sup>	External pullup voltage for open-drain pins (SDA, SCL, GPOUT)		1.62		3.6	V

- (1) Specified by design. Not production tested.

### 7.4 Thermal Information

THERMAL METRIC <sup>(1)</sup>		bq27621-G1			UNIT
		YZF (DSBGA)			
		9 PINS			
R <sub>θJA</sub>	Junction-to-ambient thermal resistance		107.8		°C/W
R <sub>θJC(top)</sub>	Junction-to-case (top) thermal resistance		0.7		°C/W
R <sub>θJB</sub>	Junction-to-board thermal resistance		60.4		°C/W
ψ <sub>JT</sub>	Junction-to-top characterization parameter		3.5		°C/W
ψ <sub>JB</sub>	Junction-to-board characterization parameter		60.4		°C/W
R <sub>θJC(bot)</sub>	Junction-to-case (bottom) thermal resistance		n/a		°C/W

- (1) For more information about traditional and new thermal metrics, see the *IC Package Thermal Metrics Application Report*, [SPRA953](#).

### 7.5 Supply Current

T<sub>A</sub> = 30°C and V<sub>REGIN</sub> = V<sub>BAT</sub> = 3.6 V (unless otherwise noted)

PARAMETER		TEST CONDITIONS	MIN	TYP	MAX	UNIT
I <sub>CC</sub> <sup>(1)</sup>	NORMAL mode current	I <sub>LOAD</sub> > <b>Sleep Current</b>		27		µA
I <sub>SLP</sub> <sup>(1)</sup>	SLEEP mode current	I <sub>LOAD</sub> < <b>Sleep Current</b>		21		µA

- (1) Specified by design. Not production tested.

## Supply Current (continued)

 $T_A = 30^\circ\text{C}$  and  $V_{\text{REGIN}} = V_{\text{BAT}} = 3.6\text{ V}$  (unless otherwise noted)

PARAMETER	TEST CONDITIONS	MIN	TYP	MAX	UNIT
$I_{\text{HIB}}^{(1)}$	HIBERNATE mode current	$I_{\text{LOAD}} < \text{Hibernate Current}$		9	$\mu\text{A}$
$I_{\text{SD}}^{(1)}$	SHUTDOWN mode current	Fuel gauge in host commanded SHUTDOWN mode. (LDO Regulator Output Disabled)		0.6	$\mu\text{A}$

## 7.6 Digital Input and Output DC Characteristics

 $T_A = -40^\circ\text{C}$  to  $85^\circ\text{C}$ , typical values at  $T_A = 30^\circ\text{C}$  and  $V_{\text{REGIN}} = 3.6\text{ V}$  (unless otherwise noted)

PARAMETER	TEST CONDITIONS	MIN	TYP	MAX	UNIT
$V_{\text{IH(OD)}}$	Input voltage, high <sup>(2)</sup>	External pullup resistor to $V_{\text{PU}}$		$V_{\text{PU}} \times 0.7$	V
$V_{\text{IL}}$	Input voltage, low <sup>(2) (3)</sup>			0.6	V
$V_{\text{OL}}$	Output voltage, low <sup>(2)</sup>			0.6	V
$I_{\text{OH}}$	Output source current, high <sup>(2)</sup>			0.5	mA
$I_{\text{OL(OD)}}$	Output sink current, low <sup>(2)</sup>			-3	mA
$C_{\text{IN}}^{(1)}$	Input capacitance <sup>(2) (3)</sup>			5	pF
$I_{\text{IKG}}$	Input leakage current (SCL, SDA, BIN)			0.1	$\mu\text{A}$
	Input leakage current (GPOUT)			1	

(1) Specified by design. Not production tested.

(2) Open drain pins: (SCL, SDA, GPOUT)

(3) Push-pull pin: (BIN)

## 7.7 LDO Regulator, Wake-up, and Auto-Shutdown DC Characteristics

 $T_A = -40^\circ\text{C}$  to  $85^\circ\text{C}$ , typical values at  $T_A = 30^\circ\text{C}$  and  $V_{\text{REGIN}} = 3.6\text{ V}$  (unless otherwise noted)

PARAMETER	TEST CONDITIONS	MIN	TYP	MAX	UNIT
$V_{\text{BAT}}$	BAT pin regulator input	2.45		4.5	V
$V_{\text{DD}}$	Regulator output voltage		1.8		V
$UVLO_{\text{IT+}}$	$V_{\text{BAT}}$ Undervoltage Lock Out LDO Wake-Up Rising Threshold		2		V
$UVLO_{\text{IT-}}$	$V_{\text{BAT}}$ Undervoltage Lock Out LDO Auto-Shutdown Falling Threshold		1.95		V

(1) Specified by design. Not production tested.

## 7.8 ADC (Temperature and Cell Measurement) Characteristics

 $T_A = -40^\circ\text{C}$  to  $85^\circ\text{C}$ ; typical values at  $T_A = 30^\circ\text{C}$  and  $V_{\text{REGIN}} = 3.6\text{ V}$  (unless otherwise noted)

PARAMETER	TEST CONDITIONS	MIN	TYP	MAX	UNIT
$V_{\text{IN(BAT)}}$	BAT pin voltage measurement range.	Voltage divider enabled.		4.5	V
$t_{\text{ADC\_CONV}}$	Conversion time		125		ms
	Effective Resolution		15		bits

(1) Specified by design. Not tested in production.

## 7.9 I<sup>2</sup>C-Compatible Interface Communication Timing Characteristics

 $T_A = -40^\circ\text{C}$  to  $85^\circ\text{C}$ ; typical values at  $T_A = 30^\circ\text{C}$  and  $V_{\text{REGIN}} = 3.6\text{ V}$  (unless otherwise noted)

PARAMETER	TEST CONDITIONS	MIN	NOM	MAX	UNIT
<b>Standard Mode (100 kHz)</b>					
$t_{\text{d(STA)}}$	Start to first falling edge of SCL	4			$\mu\text{s}$

(1) Specified by design. Not production tested.

## I<sup>2</sup>C-Compatible Interface Communication Timing Characteristics (continued)

$T_A = -40^{\circ}\text{C}$  to  $85^{\circ}\text{C}$ ; typical values at  $T_A = 30^{\circ}\text{C}$  and  $V_{\text{REGIN}} = 3.6\text{ V}$  (unless otherwise noted)

PARAMETER	TEST CONDITIONS	MIN	NOM	MAX	UNIT
$t_{w(L)}$	SCL pulse duration (low)	4.7			$\mu\text{s}$
$t_{w(H)}$	SCL pulse duration (high)	4			$\mu\text{s}$
$t_{su(STA)}$	Setup for repeated start	4.7			$\mu\text{s}$
$t_{su(DAT)}$	Data setup time	Host drives SDA	250		ns
$t_h(DAT)$	Data hold time	Host drives SDA	0		ns
$t_{su(STOP)}$	Setup time for stop	4			$\mu\text{s}$
$t_{(BUF)}$	Bus free time between stop and start	Includes Command Waiting Time	66		$\mu\text{s}$
$t_f$	SCL/SDA fall time <sup>(1)</sup>			300	ns
$t_r$	SCL/SDA rise time <sup>(1)</sup>			300	ns
$f_{SCL}$	Clock frequency <sup>(2)</sup>			100	kHz
<b>Fast Mode (400 kHz)</b>					
$t_{d(STA)}$	Start to first falling edge of SCL	600			ns
$t_{w(L)}$	SCL pulse duration (low)	1300			ns
$t_{w(H)}$	SCL pulse duration (high)	600			ns
$t_{su(STA)}$	Setup for repeated start	600			ns
$t_{su(DAT)}$	Data setup time	Host drives SDA	100		ns
$t_h(DAT)$	Data hold time	Host drives SDA	0		ns
$t_{su(STOP)}$	Setup time for stop	600			ns
$t_{(BUF)}$	Bus free time between stop and start	Includes Command Waiting Time	66		$\mu\text{s}$
$t_f$	SCL/SDA fall time <sup>(1)</sup>			300	ns
$t_r$	SCL/SDA rise time <sup>(1)</sup>			300	ns
$f_{SCL}$	Clock frequency <sup>(2)</sup>			400	kHz

(2) If the clock frequency ( $f_{SCL}$ ) is  $> 100\text{ kHz}$ , use 1-byte write commands for proper operation. All other transactions types are supported at 400 kHz. (Refer to [I<sup>2</sup>C Interface](#) and [I<sup>2</sup>C Command Waiting Time](#)).

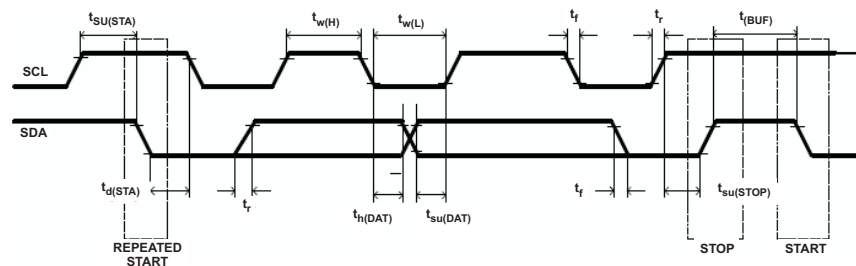

**Figure 1. I<sup>2</sup>C-Compatible Interface Timing Diagrams**

## 7.10 Typical Characteristics

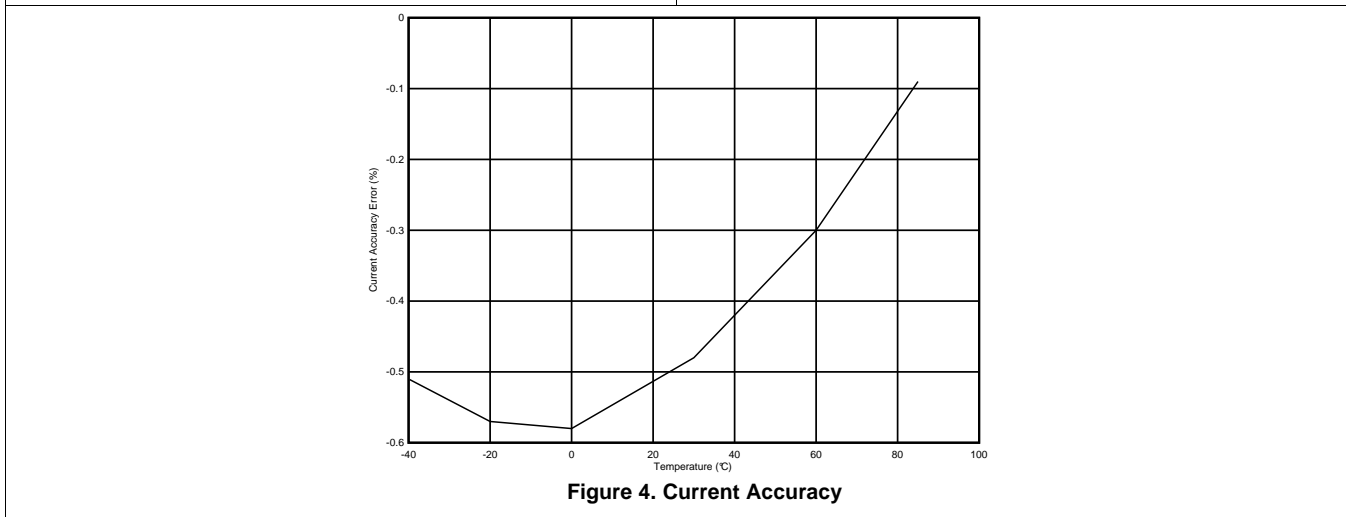
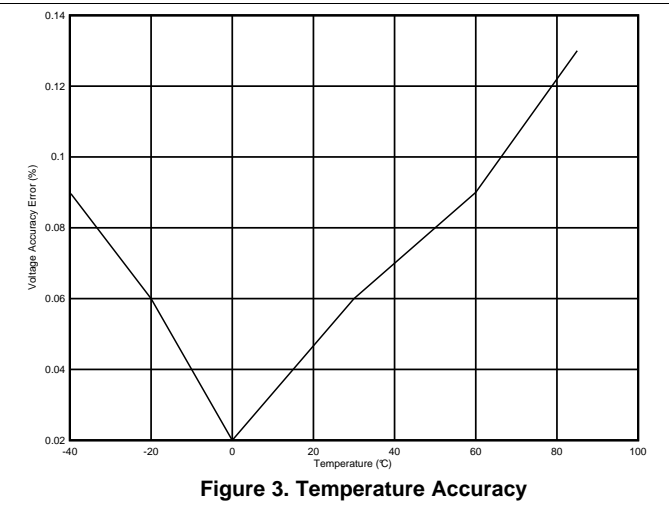
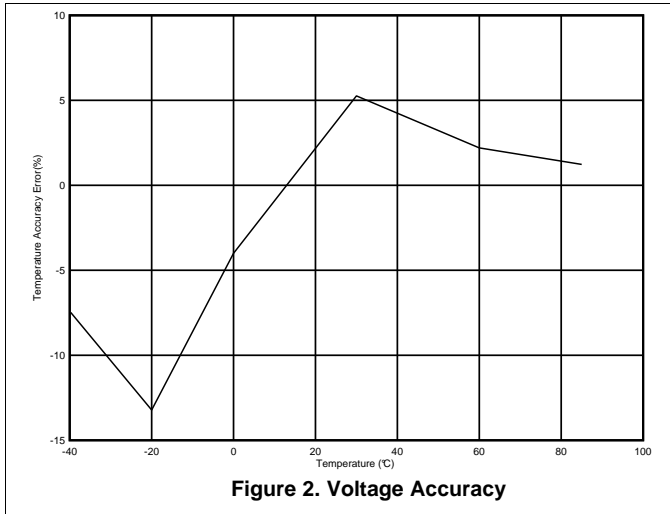

## 8 Detailed Description

### 8.1 Overview

The bq27621-G1 battery fuel gauge accurately predicts the battery capacity and other operational characteristics of a single Li-based rechargeable cell. It can be interrogated by a system processor to provide cell information such as **State of Charge** (%) and **Remaining Capacity** (mAh). The device is preconfigured with three battery profiles. The default profile is for standard LiCoO<sub>2</sub>-based batteries with a maximum charge voltage of 4.2 V. The other two profiles that can be selected via I<sup>2</sup>C commands are for batteries with charging voltages of 4.3 V and 4.35 V.

Unlike some other fuel gauges, the bq27621-G1 fuel gauge cannot be programmed with specific battery chemistry profiles. For many battery types and applications, the predefined standard chemistry profiles available in the bq27621-G1 fuel gauge are sufficient matches from a gauging perspective.

---

### NOTE

#### Formatting conventions used in this document:

Commands: *italics* with *parentheses* and no breaking spaces, for example: *RemainingCapacity()*

Data Memory Configuration Parameter: *italics*, **bold**, and *breaking spaces*, for example: **Design Capacity**

Register bits and flags: brackets and *italics*, for example: *[ITPOR]*

Data Memory Configuration Parameter bits: brackets, *italics* and **bold**, for example: **[BIE]**

Modes and states: ALL CAPITALS, for example: UNSEALED mode

---

### 8.2 Functional Block Diagram

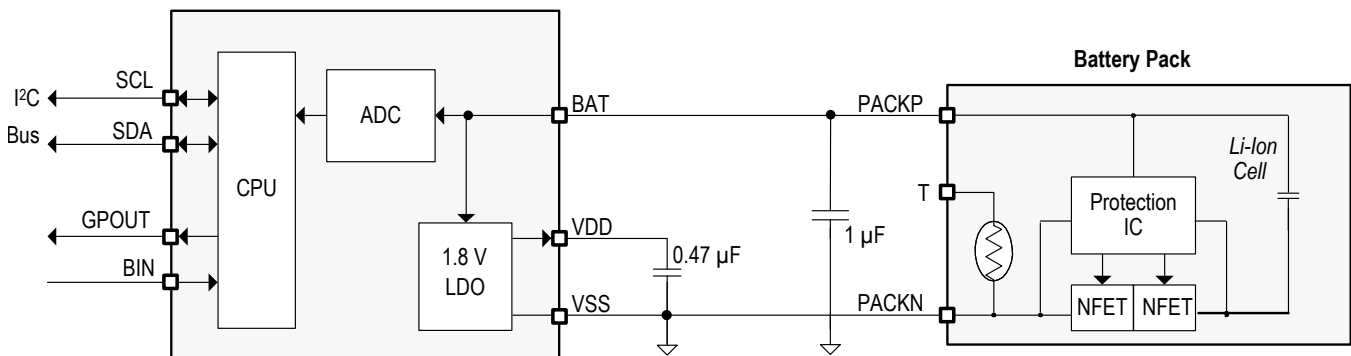

### 8.3 Feature Description

Information is accessed through a series of commands, called *Standard Commands*. Further capabilities are provided by the additional *Extended Commands* set. Both sets of commands, indicated by the general format *Command()*, are used to read and write information contained within the control and status registers, as well as its data locations. Commands are sent from system to gauge using the I<sup>2</sup>C serial communications engine, and can be executed during application development, system manufacture, or end-equipment operation.

The key to the fuel gauging prediction of the bq27621-G1 fuel gauge is Texas Instruments proprietary Dynamic Voltage Correlation algorithm. This algorithm eliminates the need for a sense resistor when calculating remaining battery capacity (mAh) and state-of-charge (%). This algorithm uses cell voltage measurements and cell characteristics to create state-of-charge predictions that can achieve high accuracy across a wide variety of operating conditions.

The fuel gauge estimates charge and discharge activity by monitoring the cell voltage. Cell impedance is computed based on estimated current, open-circuit voltage (OCV), and cell voltage under loaded conditions.

The fuel gauge uses an integrated temperature sensor for estimating cell temperature. Alternatively, the system processor can provide temperature data for the fuel gauge.

### 8.4 Device Functional Modes

To minimize power consumption, the fuel gauge has several power modes: INITIALIZATION, NORMAL, SLEEP, HIBERNATE, and SHUTDOWN. The fuel gauge passes automatically between these modes, depending upon the occurrence of specific events, though a system processor can initiate some of these modes directly.

The gauge can be configured and used in a matter of minutes by following the *Quickstart Guide for bq27621-G1 (SLUUAP5)*. The information in that document is sufficient for most applications. For further customization and options, more exhaustive details can be found in the *bq27621-G1 Technical Reference Manual (SLUJAD4)*.

### 8.5 Programming

#### 8.5.1 Data Commands

##### 8.5.1.1 Standard Data Commands

The bq27621-G1 uses a series of 2-byte standard commands to enable system reading and writing of battery information. Each standard command has an associated command-code pair, as indicated in [Table 1](#). Because each command consists of two bytes of data, two consecutive I<sup>2</sup>C transmissions must be executed both to initiate the command function, and to read or write the corresponding two bytes of data. Additional details are found in the *bq27621-G1 Technical Reference Manual (SLUJAD4)*.

---

#### NOTE

Data values read by the host may be invalid during initialization for a period of up to 3 seconds.

---

**Table 1. Standard Commands**

NAME		COMMAND CODE	UNIT	SEALED ACCESS
<i>Control()</i>	CNTL	0x00 and 0x01	NA	R/W
<i>Temperature()</i>	TEMP	0x02 and 0x03	0.1°K	R/W
<i>Voltage()</i>	VOLT	0x04 and 0x05	mV	R
<i>Flags()</i>	FLAGS	0x06 and 0x07	NA	R
<i>NominalAvailableCapacity()</i>		0x08 and 0x09	mAh	R
<i>FullAvailableCapacity()</i>		0x0A and 0x0B	mAh	R
<i>RemainingCapacity()</i>	RM	0x0C and 0x0D	mAh	R
<i>FullChargeCapacity()</i>	FCC	0x0E and 0x0F	mAh	R
<i>EffectiveCurrent()</i>		0x10 and 0x11	mA	R
<i>AveragePower()</i>		0x18 and 0x19	mW	R
<i>StateOfCharge()</i>	SOC	0x1C and 0x1D	%	R
<i>InternalTemperature()</i>		0x1E and 0x1F	0.1°K	R
<i>RemainingCapacityUnfiltered()</i>		0x28 and 0x29	mAh	R
<i>RemainingCapacityFiltered()</i>		0x2A and 0x2B	mAh	R
<i>FullChargeCapacityUnfiltered()</i>		0x2C and 0x2D	mAh	R
<i>FullChargeCapacityFiltered()</i>		0x2E and 0x2F	mAh	R
<i>StateOfChargeUnfiltered()</i>		0x30 and 0x31	mAh	R
<i>OperationConfiguration()</i>		0x3A and 0x3B	NA	R

### 8.5.1.2 Control(): 0x00 and 0x01

Issuing a *Control()* command requires a subsequent 2-byte subcommand. These additional bytes specify the particular control function desired. The *Control()* command allows the system to control specific features of the fuel gauge during normal operation and additional features when the device is in different access modes. Additional details are found in the *bq27621-G1 Technical Reference Manual (SLUUAD4)*.

**Table 2. Control() Subcommands**

CNTL FUNCTION	CNTL DATA	SEALED ACCESS	DESCRIPTION
CONTROL_STATUS	0x0000	Yes	Reports the status of device.
DEVICE_TYPE	0x0001	Yes	Reports the device type (0x0621).
FW_VERSION	0x0002	Yes	Reports the firmware version of the device.
PREV_MACWRITE	0x0007	Yes	Returns previous MAC command code.
CHEM_ID	0x0008	Yes	Reports the chemical identifier of the battery profile currently used by the fuel gauging algorithm
BAT_INSERT	0x000C	Yes	Forces the [BAT_DET] bit set when the [BIE] bit is 0.
BAT_REMOVE	0x000D	Yes	Forces the [BAT_DET] bit clear when the [BIE] bit is 0.
TOGGLE_POWERMIN	0x0010	Yes	Set CONTROL_STATUS [POWERMIN] to 1.
SET_HIBERNATE	0x0011	Yes	Forces CONTROL_STATUS [HIBERNATE] to 1.
CLEAR_HIBERNATE	0x0012	Yes	Forces CONTROL_STATUS [HIBERNATE] to 0.
SET_CFGUPDATE	0x0013	No	Force CONTROL_STATUS [CFGUPMODE] to 1 and gauge enters CONFIG UPDATE mode.
SHUTDOWN_ENABLE	0x001B	No	Enables device SHUTDOWN mode.
SHUTDOWN	0x001C	No	Commands the device to enter SHUTDOWN mode.
SEALED	0x0020	No	Places the device in SEALED access mode.
TOGGLE_GPOUT	0x0023	Yes	Test the GPIO pin by sending a pulse signal
ALT_CHEM1	0x0031	No	Selects alternate chemistry 1 (0x1210)
ALT_CHEM2	0x0032	No	Selects alternate chemistry 2 (0x354)
RESET	0x0041	No	Performs a full device reset.
SOFT_RESET	0x0042	No	Gauge exits CONFIG UPDATE mode.
EXIT_CFGUPDATE	0x0043	No	Exits CONFIG UPDATE mode without an OCV measurement and without resimulating to update <i>StateOfCharge()</i> .
EXIT_RESIM	0x0044	No	Exits CONFIG UPDATE mode without an OCV measurement and resimulates with the updated configuration data to update <i>StateOfCharge()</i> .

### 8.5.2 Alternate Chemistry Selection

The fuel gauge allows the user to change the chemistry settings using I<sup>2</sup>C commands. The default chemistry has a CHEM\_ID of 0x1202. The two other CHEM\_IDs supported by this device includes CHEM\_ID 0x1210 and CHEM\_ID 0x354. The detailed procedure to change the chemistry is available in the *bq27621-G1 Technical Reference Manual (SLUUAD4)*.

### 8.5.3 Communications

#### 8.5.3.1 I<sup>2</sup>C Interface

The bq27621-G1 fuel gauge supports the standard I<sup>2</sup>C read, incremental read, quick read, one-byte write, and incremental write functions. The 7-bit device address (ADDR) is the most significant 7 bits of the hex address and is fixed as 1010101. The first 8 bits of the I<sup>2</sup>C protocol are, therefore, 0xAA or 0xAB for write or read, respectively.

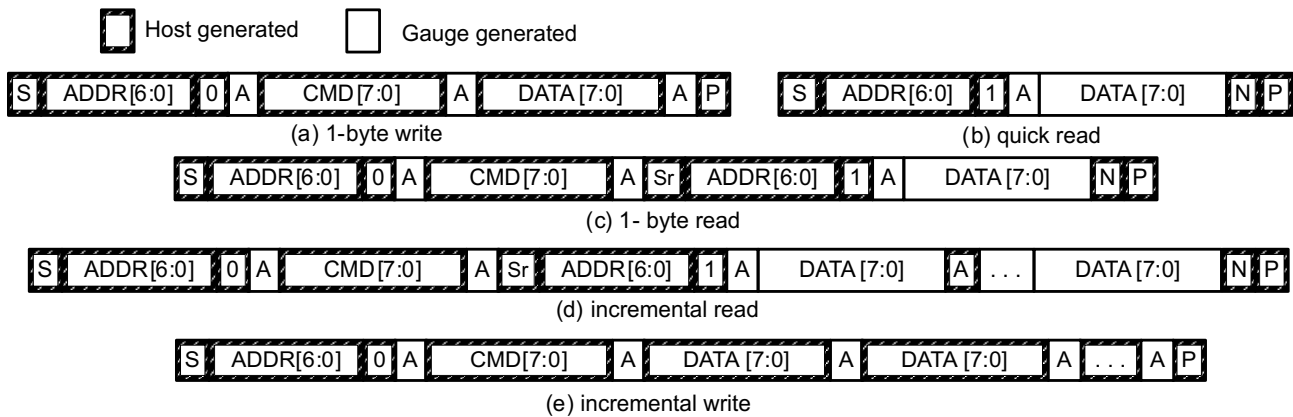

(S = Start, Sr = Repeated Start, A = Acknowledge, N = No Acknowledge, and P = Stop).

**Figure 5. I<sup>2</sup>C Format**

The quick read returns data at the address indicated by the address pointer. The address pointer, a register internal to the I<sup>2</sup>C communication engine, increments whenever data is acknowledged by the fuel gauge or the I<sup>2</sup>C master. The quick writes function in the same manner and are a convenient means of sending multiple bytes to consecutive command locations (such as two-byte commands that require two bytes of data).

The following command sequences are not supported:



**Figure 6. Attempt To Write a Read-only Address (Nack After Data Sent By Master)**



**Figure 7. Attempt To Read an Address Above 0x6B (Nack Command)**

**8.5.3.2 I<sup>2</sup>C Time Out**

The I<sup>2</sup>C engine releases both SDA and SCL if the I<sup>2</sup>C bus is held low for 2 seconds. If the fuel gauge is holding the lines, releasing them frees them for the master to drive the lines.

### 8.5.3.3 I<sup>2</sup>C Command Waiting Time

To ensure proper operation at 400 kHz, a  $t_{(BUF)} \geq 66 \mu s$  bus-free waiting time must be inserted between all packets addressed to the fuel gauge. In addition, if the SCL clock frequency ( $f_{SCL}$ ) is  $> 100$  kHz, use individual 1-byte write commands for proper data flow control. The following diagram shows the standard waiting time required between issuing the control subcommand the reading the status result. For read-write standard command, a minimum of 2 seconds is required to get the result updated. For read-only standard commands, there is no waiting time required, but the host must not issue any standard command more than two times per second. Otherwise, the gauge could result in a reset issue due to the expiration of the watchdog timer.

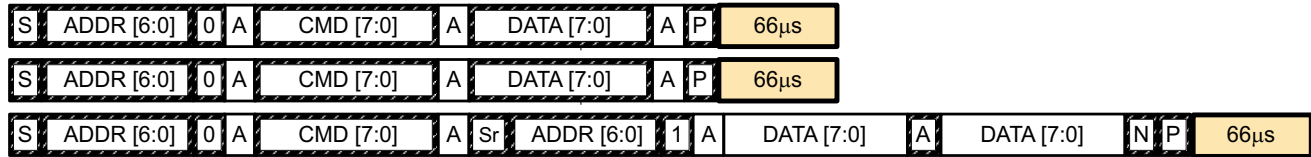

Waiting time inserted between two 1-byte write packets for a subcommand and reading results  
(required for  $100 \text{ kHz} < f_{SCL} \leq 400 \text{ kHz}$ )

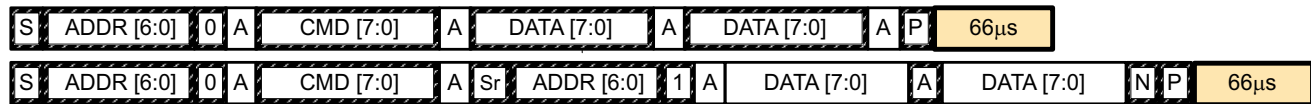

Waiting time inserted between incremental 2-byte write packet for a subcommand and reading results  
(acceptable for  $f_{SCL} \leq 100 \text{ kHz}$ )



Waiting time inserted after incremental read

**Figure 8. I<sup>2</sup>C Command Wait Time**

### 8.5.3.4 I<sup>2</sup>C Clock Stretching

A clock stretch of up to 4 ms can occur during all modes of fuel gauge operation. In SLEEP and HIBERNATE modes, a short clock stretch occurs on all I<sup>2</sup>C traffic as the device must wake-up to process the packet. In the other modes (INITIALIZATION, NORMAL) clock stretching only occurs for packets addressed for the fuel gauge. The majority of clock stretch periods are small as the I<sup>2</sup>C interface performs normal data flow control.

## 9 Application and Implementation

### NOTE

Information in the following applications sections is not part of the TI component specification, and TI does not warrant its accuracy or completeness. TI's customers are responsible for determining suitability of components for their purposes. Customers should validate and test their design implementation to confirm system functionality.

### 9.1 Application Information

The Texas Instruments bq27621-G1 fuel gauge accurately predicts the battery capacity and other operational characteristics of a single Li-base rechargeable cell.

### 9.2 Typical Application

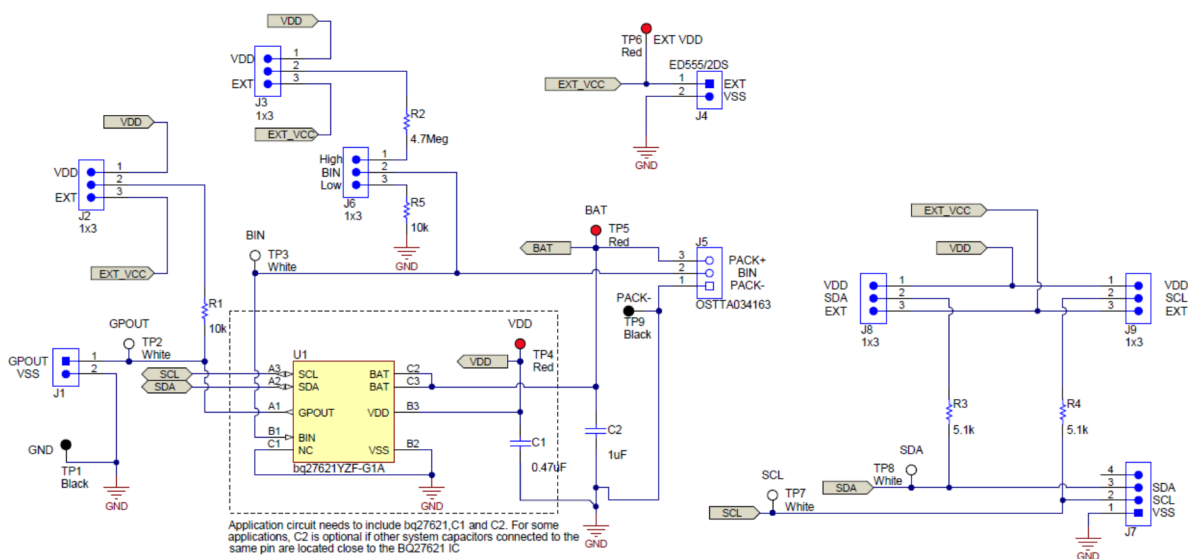

Figure 9. Reference (EVM) Schematic

#### 9.2.1 Design Requirements

The bq27621-G1 fuel gauge is predefined for LiCoO<sub>2</sub>-based batteries, which have 4.2-V, 4.3-V, and 4.35-V maximum charging voltages. One orderable part number contains three different battery profiles, which can be selected using I<sup>2</sup>C commands. Please refer to the *bq27621-G1 Technical Reference Manual (SLUUAD4)* for the procedure to select alternate chemistry profiles.

#### 9.2.2 Detailed Design Procedure

##### 9.2.2.1 BAT Voltage Sense Input

A ceramic capacitor at the input to the BAT pin is used to bypass AC voltage ripple to ground, greatly reducing its influence on battery voltage measurements. It proves most effective in applications with load profiles that exhibit high-frequency current pulses (that is, cell phones) but is recommended for use in all applications to reduce noise on this sensitive high-impedance measurement node.

##### 9.2.2.2 Integrated LDO Capacitor

The fuel gauge has an integrated LDO with an output on the VDD pin of approximately 1.8 V. A capacitor of value at least 0.47 µF should be connected between the VDD pin and VSS. The capacitor should be placed close to the gauge IC and have short traces to both the VDD pin and VSS.

Typical Application (continued)

9.2.3 Application Curves

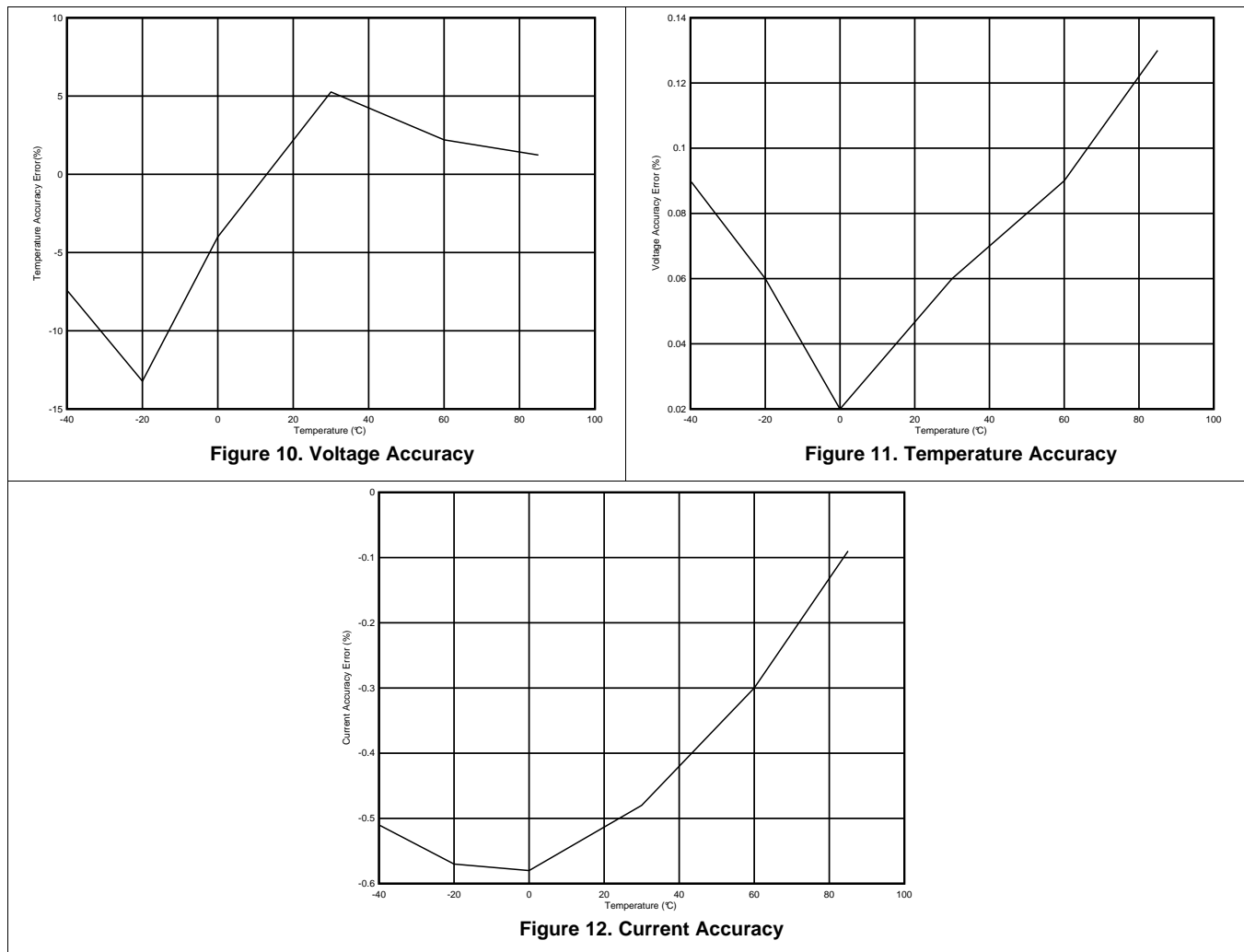

## 10 Power Supply Recommendations

### 10.1 Power Supply Decoupling

The battery connection on the BAT pin is used for two purposes: • To supply power to the fuel gauge • As an input for voltage measurement of the battery A capacitor of value of at least 1  $\mu\text{F}$  should be connected between BAT and VSS. The capacitor should be placed close to the gauge IC and have short traces to both the BAT pin and VSS. The fuel gauge has an integrated LDO with an output on the VDD pin of approximately 1.8 V. A capacitor of value at least 0.47  $\mu\text{F}$  should be connected between the VDD pin and VSS. The capacitor should be placed close to the gauge IC and have short traces to both the VDD pin and VSS.

## 11 Layout

### 11.1 Layout Guidelines

- A capacitor, of value at least 0.47  $\mu\text{F}$ , is connected between the  $V_{\text{DD}}$  pin and  $V_{\text{SS}}$ . The capacitor should be placed close to the gauge IC and have short traces to both the  $V_{\text{DD}}$  pin and  $V_{\text{SS}}$ .
- It is required to have a capacitor, at least 1.0  $\mu\text{F}$ , connected between the BAT pin and  $V_{\text{SS}}$  if the connection between the battery pack and the gauge BAT pin has the potential to pick up noise. The capacitor should be placed close to the gauge IC and have short traces to both the  $V_{\text{DD}}$  pin and  $V_{\text{SS}}$ .
- If the external pullup resistors on the SCL and SDA lines will be disconnected from the host during low-power operation, it is recommend to use external 1-M $\Omega$  pulldown resistors to  $V_{\text{SS}}$  to avoid floating inputs to the I<sup>2</sup>C engine.
- The value of the SCL and SDA pullup resistors should take into consideration the pullup voltage and the bus capacitance. Some recommended values, assuming a bus capacitance of 10 pF, can be seen in [Table 3](#).

**Table 3. Recommended Values for SCL and SDA Pullup Resistors**

VPU	1.8 V		3.3 V	
$R_{\text{PU}}$	Range	Typical	Range	Typical
	$400 \Omega \leq R_{\text{PU}} \leq 37.6 \text{ k}\Omega$	10 k $\Omega$	$900 \Omega \leq R_{\text{PU}} \leq 29.2 \text{ k}\Omega$	5.1 k $\Omega$

- If the GPOUT pin is not used by the host, the pin should still be pulled up to  $V_{\text{DD}}$  with a 4.7-k $\Omega$  or 10-k $\Omega$  resistor.
- If the battery pack thermistor is not connected to the BIN pin, the BIN pin should be pulled down to  $V_{\text{SS}}$  with a 10-k $\Omega$  resistor.
- The BIN pin should not be shorted directly to  $V_{\text{DD}}$  or  $V_{\text{SS}}$ .
- The actual device ground is the center pin (B2). The C1 pin is floating internally and can be used as a bridge to connect the board ground plane to the device ground (B2).

### 11.2 Layout Example

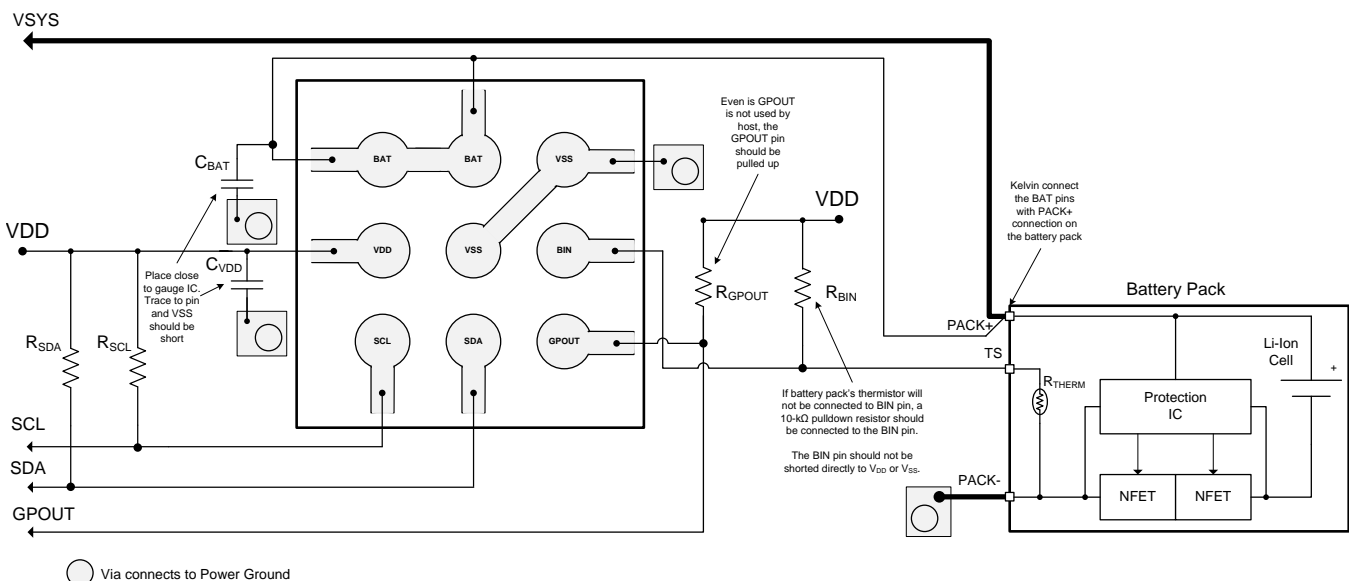

**Figure 13. Layout Example**

## 12 Device and Documentation Support

### 12.1 Documentation Support

#### 12.1.1 Related Documentation

To obtain a copy of any of the following TI documents, call the Texas Instruments Literature Response Center at (800) 477-8924 or the Product Information Center (PIC) at (972) 644-5580. When ordering, identify this document by its title and literature number. Updated documents also can be obtained through the TI Web site at [www.ti.com](http://www.ti.com).

1. *bq27621-G1 Technical Reference User's Guide* ([SLUUAD4](#))
2. *bq27621 EVM: Single-Cell Technology User's Guide* ([SLUUAM6](#))
3. *Quickstart Guide for bq27621-G1* ([SLUUAP5](#))

### 12.2 Community Resources

The following links connect to TI community resources. Linked contents are provided "AS IS" by the respective contributors. They do not constitute TI specifications and do not necessarily reflect TI's views; see TI's [Terms of Use](#).

**TI E2E™ Online Community** *TI's Engineer-to-Engineer (E2E) Community*. Created to foster collaboration among engineers. At [e2e.ti.com](http://e2e.ti.com), you can ask questions, share knowledge, explore ideas and help solve problems with fellow engineers.

**Design Support** *TI's Design Support* Quickly find helpful E2E forums along with design support tools and contact information for technical support.

### 12.3 Trademarks

E2E is a trademark of Texas Instruments.  
All other trademarks are the property of their respective owners.

### 12.4 Electrostatic Discharge Caution



This integrated circuit can be damaged by ESD. Texas Instruments recommends that all integrated circuits be handled with appropriate precautions. Failure to observe proper handling and installation procedures can cause damage.

ESD damage can range from subtle performance degradation to complete device failure. Precision integrated circuits may be more susceptible to damage because very small parametric changes could cause the device not to meet its published specifications.

### 12.5 Glossary

[SLYZ022](#) — *TI Glossary*.

This glossary lists and explains terms, acronyms, and definitions.

## 13 Mechanical, Packaging, and Orderable Information

The following pages include mechanical, packaging, and orderable information. This information is the most current data available for the designated devices. This data is subject to change without notice and revision of this document. For browser-based versions of this data sheet, refer to the left-hand navigation.

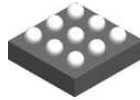

**YZF0009-C01**

**PACKAGE OUTLINE**  
**DSBGA - 0.625 mm max height**

DIE SIZE BALL GRID ARRAY

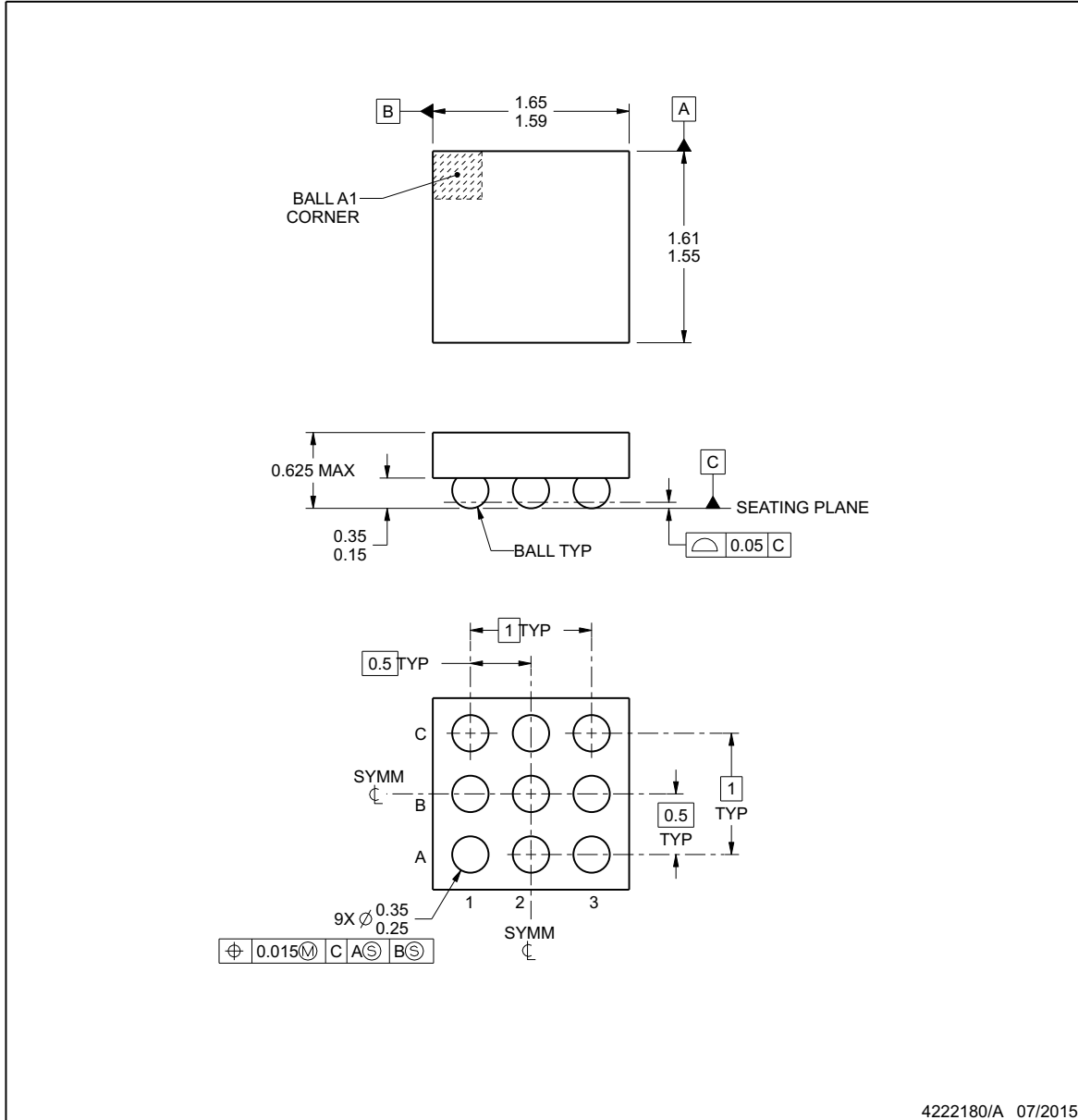

NOTES:

NanoFree is a trademark of Texas Instruments.

1. All linear dimensions are in millimeters. Any dimensions in parenthesis are for reference only. Dimensioning and tolerancing per ASME Y14.5M.
2. This drawing is subject to change without notice.
3. NanoFree™ package configuration.

**EXAMPLE BOARD LAYOUT**

**YZF0009-C01**

**DSBGA - 0.625 mm max height**

DIE SIZE BALL GRID ARRAY

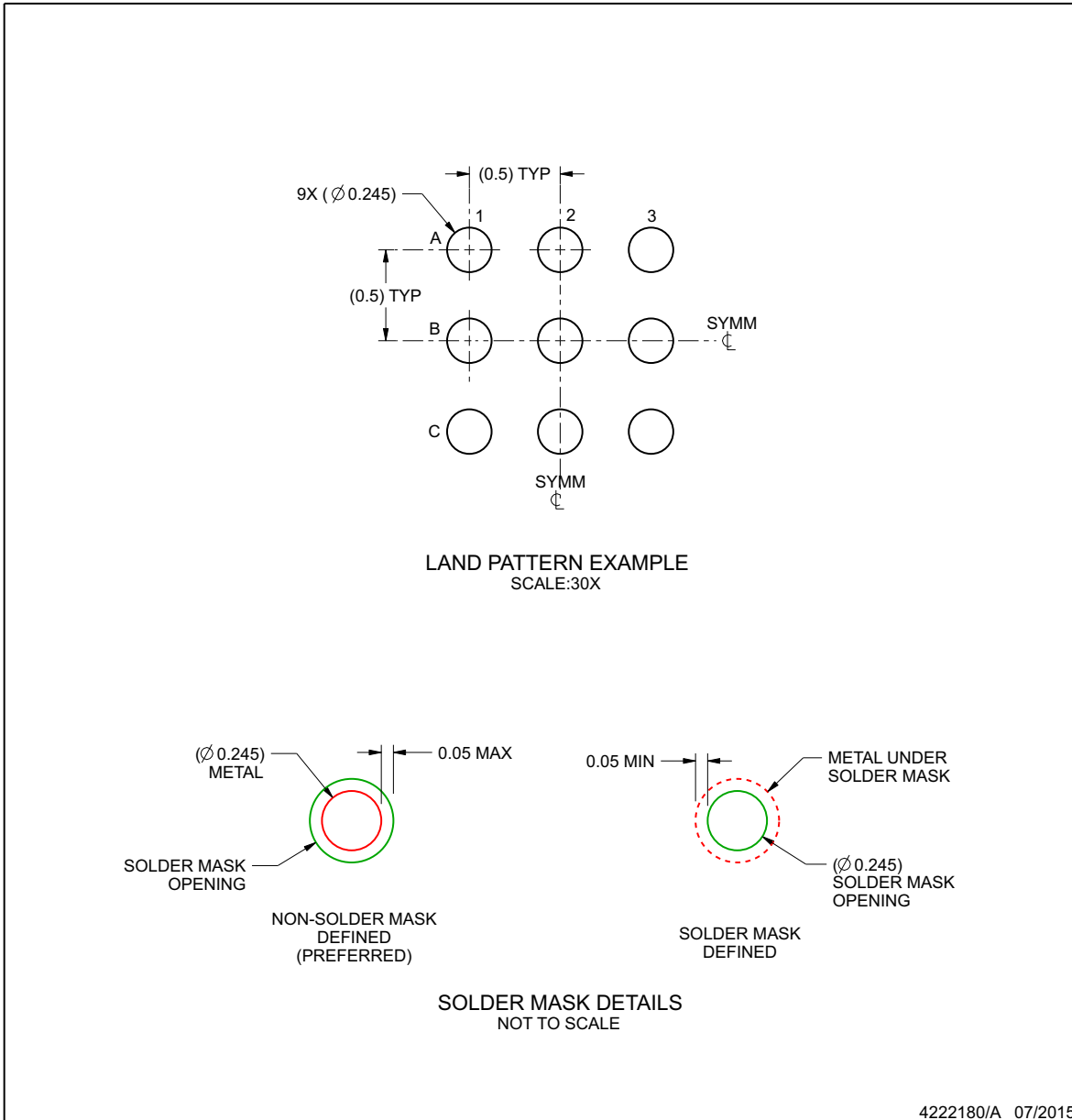

NOTES: (continued)

- Final dimensions may vary due to manufacturing tolerance considerations and also routing constraints. For more information, see Texas Instruments literature number SNVA009 ([www.ti.com/lit/snva009](http://www.ti.com/lit/snva009)).

**EXAMPLE STENCIL DESIGN**

**YZF0009-C01**

**DSBGA - 0.625 mm max height**

DIE SIZE BALL GRID ARRAY

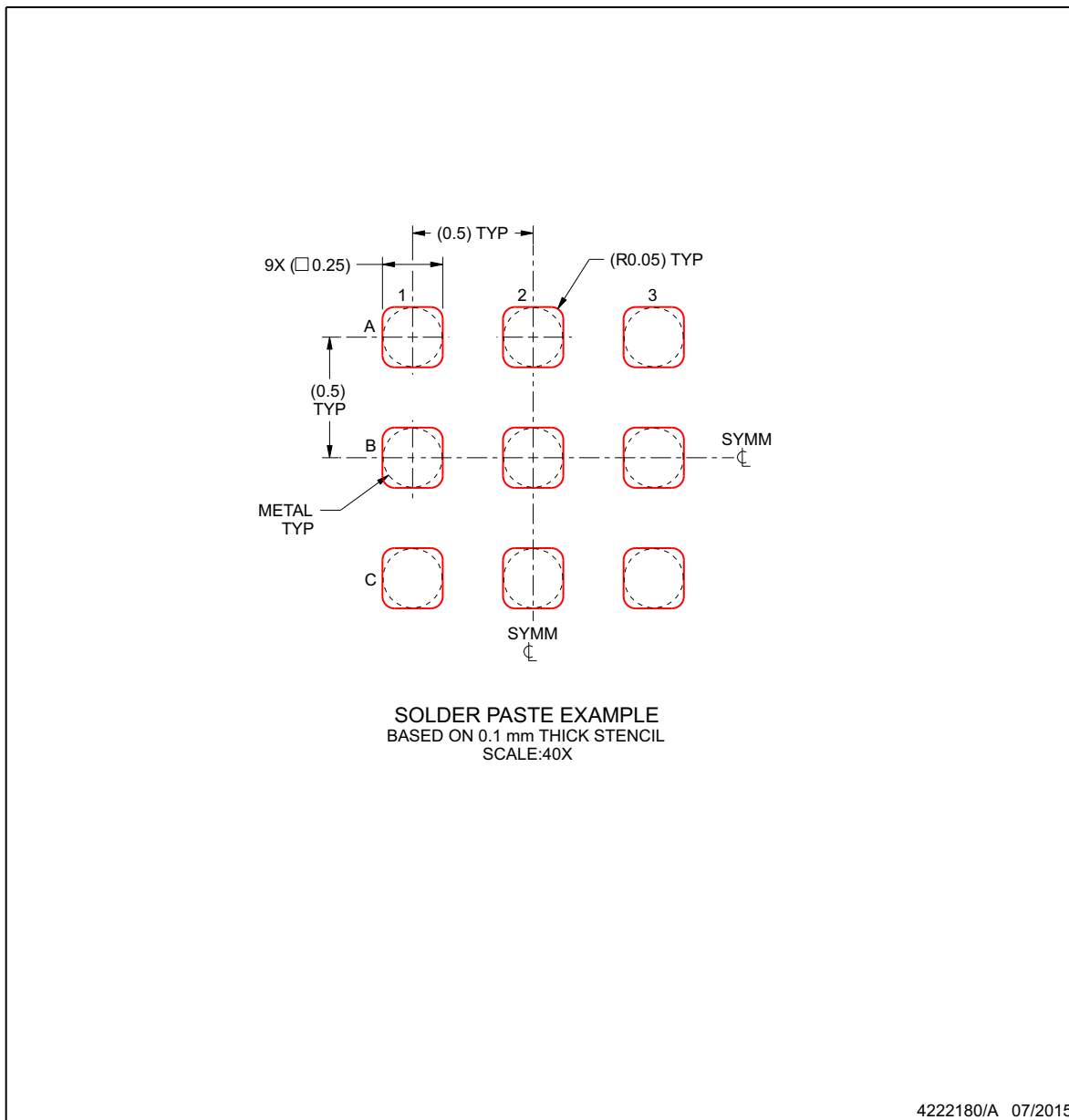

NOTES: (continued)

- 5. Laser cutting apertures with trapezoidal walls and rounded corners may offer better paste release.

**PACKAGING INFORMATION**

Orderable Device	Status (1)	Package Type	Package Drawing	Pins	Package Qty	Eco Plan (2)	Lead/Ball Finish (6)	MSL Peak Temp (3)	Op Temp (°C)	Device Marking (4/5)	Samples
BQ27621YZFR-G1A	ACTIVE	DSBGA	YZF	9	3000	Green (RoHS & no Sb/Br)	SNAGCU	Level-1-260C-UNLIM	-40 to 85	BQ27621 G1A	<a href="#">Samples</a>
BQ27621YZFT-G1A	ACTIVE	DSBGA	YZF	9	250	Green (RoHS & no Sb/Br)	SNAGCU	Level-1-260C-UNLIM	-40 to 85	BQ27621 G1A	<a href="#">Samples</a>

(1) The marketing status values are defined as follows:

**ACTIVE:** Product device recommended for new designs.

**LIFEBUY:** TI has announced that the device will be discontinued, and a lifetime-buy period is in effect.

**NRND:** Not recommended for new designs. Device is in production to support existing customers, but TI does not recommend using this part in a new design.

**PREVIEW:** Device has been announced but is not in production. Samples may or may not be available.

**OBSELETE:** TI has discontinued the production of the device.

(2) Eco Plan - The planned eco-friendly classification: Pb-Free (RoHS), Pb-Free (RoHS Exempt), or Green (RoHS & no Sb/Br) - please check <http://www.ti.com/productcontent> for the latest availability information and additional product content details.

**TBD:** The Pb-Free/Green conversion plan has not been defined.

**Pb-Free (RoHS):** TI's terms "Lead-Free" or "Pb-Free" mean semiconductor products that are compatible with the current RoHS requirements for all 6 substances, including the requirement that lead not exceed 0.1% by weight in homogeneous materials. Where designed to be soldered at high temperatures, TI Pb-Free products are suitable for use in specified lead-free processes.

**Pb-Free (RoHS Exempt):** This component has a RoHS exemption for either 1) lead-based flip-chip solder bumps used between the die and package, or 2) lead-based die adhesive used between the die and leadframe. The component is otherwise considered Pb-Free (RoHS compatible) as defined above.

**Green (RoHS & no Sb/Br):** TI defines "Green" to mean Pb-Free (RoHS compatible), and free of Bromine (Br) and Antimony (Sb) based flame retardants (Br or Sb do not exceed 0.1% by weight in homogeneous material)

(3) MSL, Peak Temp. - The Moisture Sensitivity Level rating according to the JEDEC industry standard classifications, and peak solder temperature.

(4) There may be additional marking, which relates to the logo, the lot trace code information, or the environmental category on the device.

(5) Multiple Device Markings will be inside parentheses. Only one Device Marking contained in parentheses and separated by a "~" will appear on a device. If a line is indented then it is a continuation of the previous line and the two combined represent the entire Device Marking for that device.

(6) Lead/Ball Finish - Orderable Devices may have multiple material finish options. Finish options are separated by a vertical ruled line. Lead/Ball Finish values may wrap to two lines if the finish value exceeds the maximum column width.

**Important Information and Disclaimer:** The information provided on this page represents TI's knowledge and belief as of the date that it is provided. TI bases its knowledge and belief on information provided by third parties, and makes no representation or warranty as to the accuracy of such information. Efforts are underway to better integrate information from third parties. TI has taken and continues to take reasonable steps to provide representative and accurate information but may not have conducted destructive testing or chemical analysis on incoming materials and chemicals. TI and TI suppliers consider certain information to be proprietary, and thus CAS numbers and other limited information may not be available for release.

In no event shall TI's liability arising out of such information exceed the total purchase price of the TI part(s) at issue in this document sold by TI to Customer on an annual basis.

## TAPE AND REEL INFORMATION



### QUADRANT ASSIGNMENTS FOR PIN 1 ORIENTATION IN TAPE



\*All dimensions are nominal

Device	Package Type	Package Drawing	Pins	SPQ	Reel Diameter (mm)	Reel Width W1 (mm)	A0 (mm)	B0 (mm)	K0 (mm)	P1 (mm)	W (mm)	Pin1 Quadrant
BQ27621YZFR-G1A	DSBGA	YZF	9	3000	180.0	8.4	1.78	1.78	0.69	4.0	8.0	Q1
BQ27621YZFT-G1A	DSBGA	YZF	9	250	180.0	8.4	1.78	1.78	0.69	4.0	8.0	Q1

**TAPE AND REEL BOX DIMENSIONS**

\*All dimensions are nominal

Device	Package Type	Package Drawing	Pins	SPQ	Length (mm)	Width (mm)	Height (mm)
BQ27621YZFR-G1A	DSBGA	YZF	9	3000	182.0	182.0	20.0
BQ27621YZFT-G1A	DSBGA	YZF	9	250	182.0	182.0	20.0

## IMPORTANT NOTICE

Texas Instruments Incorporated and its subsidiaries (TI) reserve the right to make corrections, enhancements, improvements and other changes to its semiconductor products and services per JESD46, latest issue, and to discontinue any product or service per JESD48, latest issue. Buyers should obtain the latest relevant information before placing orders and should verify that such information is current and complete. All semiconductor products (also referred to herein as "components") are sold subject to TI's terms and conditions of sale supplied at the time of order acknowledgment.

TI warrants performance of its components to the specifications applicable at the time of sale, in accordance with the warranty in TI's terms and conditions of sale of semiconductor products. Testing and other quality control techniques are used to the extent TI deems necessary to support this warranty. Except where mandated by applicable law, testing of all parameters of each component is not necessarily performed.

TI assumes no liability for applications assistance or the design of Buyers' products. Buyers are responsible for their products and applications using TI components. To minimize the risks associated with Buyers' products and applications, Buyers should provide adequate design and operating safeguards.

TI does not warrant or represent that any license, either express or implied, is granted under any patent right, copyright, mask work right, or other intellectual property right relating to any combination, machine, or process in which TI components or services are used. Information published by TI regarding third-party products or services does not constitute a license to use such products or services or a warranty or endorsement thereof. Use of such information may require a license from a third party under the patents or other intellectual property of the third party, or a license from TI under the patents or other intellectual property of TI.

Reproduction of significant portions of TI information in TI data books or data sheets is permissible only if reproduction is without alteration and is accompanied by all associated warranties, conditions, limitations, and notices. TI is not responsible or liable for such altered documentation. Information of third parties may be subject to additional restrictions.

Resale of TI components or services with statements different from or beyond the parameters stated by TI for that component or service voids all express and any implied warranties for the associated TI component or service and is an unfair and deceptive business practice. TI is not responsible or liable for any such statements.

Buyer acknowledges and agrees that it is solely responsible for compliance with all legal, regulatory and safety-related requirements concerning its products, and any use of TI components in its applications, notwithstanding any applications-related information or support that may be provided by TI. Buyer represents and agrees that it has all the necessary expertise to create and implement safeguards which anticipate dangerous consequences of failures, monitor failures and their consequences, lessen the likelihood of failures that might cause harm and take appropriate remedial actions. Buyer will fully indemnify TI and its representatives against any damages arising out of the use of any TI components in safety-critical applications.

In some cases, TI components may be promoted specifically to facilitate safety-related applications. With such components, TI's goal is to help enable customers to design and create their own end-product solutions that meet applicable functional safety standards and requirements. Nonetheless, such components are subject to these terms.

No TI components are authorized for use in FDA Class III (or similar life-critical medical equipment) unless authorized officers of the parties have executed a special agreement specifically governing such use.

Only those TI components which TI has specifically designated as military grade or "enhanced plastic" are designed and intended for use in military/aerospace applications or environments. Buyer acknowledges and agrees that any military or aerospace use of TI components which have **not** been so designated is solely at the Buyer's risk, and that Buyer is solely responsible for compliance with all legal and regulatory requirements in connection with such use.

TI has specifically designated certain components as meeting ISO/TS16949 requirements, mainly for automotive use. In any case of use of non-designated products, TI will not be responsible for any failure to meet ISO/TS16949.

### Products

Audio	<a href="http://www.ti.com/audio">www.ti.com/audio</a>
Amplifiers	<a href="http://amplifier.ti.com">amplifier.ti.com</a>
Data Converters	<a href="http://dataconverter.ti.com">dataconverter.ti.com</a>
DLP® Products	<a href="http://www.dlp.com">www.dlp.com</a>
DSP	<a href="http://dsp.ti.com">dsp.ti.com</a>
Clocks and Timers	<a href="http://www.ti.com/clocks">www.ti.com/clocks</a>
Interface	<a href="http://interface.ti.com">interface.ti.com</a>
Logic	<a href="http://logic.ti.com">logic.ti.com</a>
Power Mgmt	<a href="http://power.ti.com">power.ti.com</a>
Microcontrollers	<a href="http://microcontroller.ti.com">microcontroller.ti.com</a>
RFID	<a href="http://www.ti-rfid.com">www.ti-rfid.com</a>
OMAP Applications Processors	<a href="http://www.ti.com/omap">www.ti.com/omap</a>
Wireless Connectivity	<a href="http://www.ti.com/wirelessconnectivity">www.ti.com/wirelessconnectivity</a>

### Applications

Automotive and Transportation	<a href="http://www.ti.com/automotive">www.ti.com/automotive</a>
Communications and Telecom	<a href="http://www.ti.com/communications">www.ti.com/communications</a>
Computers and Peripherals	<a href="http://www.ti.com/computers">www.ti.com/computers</a>
Consumer Electronics	<a href="http://www.ti.com/consumer-apps">www.ti.com/consumer-apps</a>
Energy and Lighting	<a href="http://www.ti.com/energy">www.ti.com/energy</a>
Industrial	<a href="http://www.ti.com/industrial">www.ti.com/industrial</a>
Medical	<a href="http://www.ti.com/medical">www.ti.com/medical</a>
Security	<a href="http://www.ti.com/security">www.ti.com/security</a>
Space, Avionics and Defense	<a href="http://www.ti.com/space-avionics-defense">www.ti.com/space-avionics-defense</a>
Video and Imaging	<a href="http://www.ti.com/video">www.ti.com/video</a>

### TI E2E Community

[e2e.ti.com](http://e2e.ti.com)

## Looking for pricing, stock, or lifecycle information?

Click below to explore more details on WIN SOURCE:

 [View BQ27621YZFT-G1A on WIN SOURCE](#)

 [Texas Instruments](#) Information

## Optimize Your Supply Chain with WIN SOURCE Solutions

-  Global Sourcing Solution
-  Obsolete Management
-  Cost Control Management
-  Shortage Management
-  Alternative Solution
-  Excess Inventory Management