

PI5L200

Precision Wide Bandwidth LanSwitch Quad 2:1 Mux/DeMux

Features

- Single 3.3V/5V supply operation
- Rail-To-Rail Operation
- Very Low Distortion: 2%
- Replaces mechanical relays
- High-performance, low-cost solution for switching between different LAN signals
- Low crosstalk: -70dB @ 30 Mbps
- Low insertion loss and On-Resistance: 6-ohms typical
- Off isolation: -55dB @ 30 Mbps
- Wide bandwidth data rates >135 Mbps
- Low Quiescent Supply Current (100nA typical)
- Packaging (Pb-free & Green available):
 - 16-pin 150-mil wide plastic QSOP (Q)
 - 16-pin 150-mil wide plastic SOIC (W)
 - 16-pin 173-mil wide plastic TSSOP (L)

Applications

- 10/100 Base-TX/T4
- 100VG-AnyLAN
- Token Ring 4/16 Mbps
- ATM25
- NIC Adapter and Hubs
- SONET OCI 51.8Mbps
- T1/E1

Block Diagram

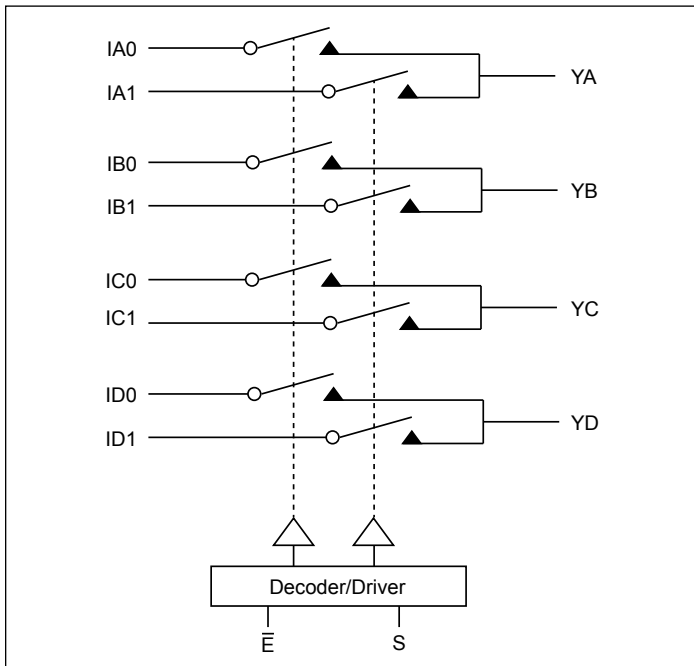

Description

Diodes' PI5L200 is a Rail-to-Rail Quad 2:1 multiplexer/demultiplexer LanSwitch with 3-state outputs. The On-Resistance typically varies from 5 ohms to 7 ohms with data inputs of 0V to 5V. Generally, this part can be used to replace mechanical relays in low voltage (3.3V/5V systems) LAN applications.

With a wide bandwidth of 135 MHz, the PI5L200 can switch Fast Ethernet and ATM25 signals. Into 100-ohm UTP cables, the switch distortion is typically less than two percent. Crosstalk @30 MHz is -70dB. The PI5L200 operates from a single 3.3V/5V supply and interface to TTL logic.

Pin Configuration

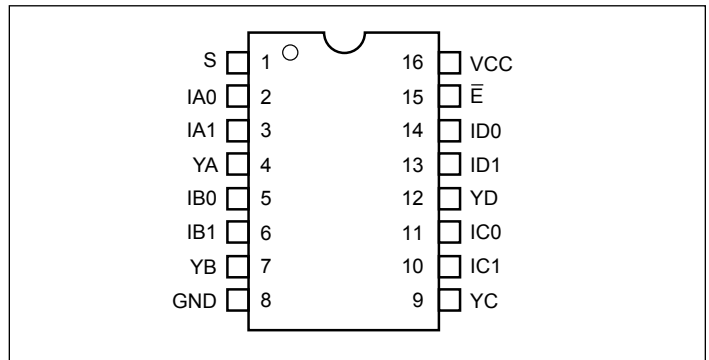

Pin Description

Pin Name	Description
IAn-IDn	Data Inputs
S	Select Inputs
E-bar	Enable
YA-YD	Data Outputs
GND	Ground
Vcc	Power

Truth Table

E-bar	S	YA	YB	YC	YD	Function
H	X	Hi-Z	Hi-Z	Hi-Z	Hi-Z	Disable
L	L	iA0	iB0	iC0	iD0	S = 0
L	H	iA1	iB1	iC1	iD1	S = 1

Note:

H = High Voltage Level,
L = Low Voltage Level, S
witches are shown with logic "0" input (Select and Enable)

Maximum Ratings

(Above which the useful life may be impaired. For user guidelines, not tested.)

Storage Temperature	-65°C to +150°C
Ambient Temperature with Power Applied	-40°C to +85°C
Supply Voltage to Ground Potential	-0.5V to +7.0V
DC Input Voltage	-0.5V to $V_{CC}+0.5V$
DC Output Current.....	120 mA
Power Dissipation	0.5W

Note:

Stresses greater than those listed under MAXIMUM RATINGS may cause permanent damage to the device. This is a stress rating only and functional operation of the device at these or any other conditions above those indicated in the operational sections of this specification is not implied. Exposure to absolute maximum rating conditions for extended periods may affect reliability.

Single 5.0V Supply

DC Electrical Characteristics (Over the Operating Range, $T_A = -40^\circ\text{C}$ to $+85^\circ\text{C}$, $V_{CC} = 5V \pm 10\%$, $GND = 0V$)

Parameters	Description	Test Conditions ⁽¹⁾	Min.	Typ. ⁽²⁾	Max.	Units
V_{ANALOG}	Analog Signal Range		0	—	V_{CC}	V
R_{ON}	ON-Resistance	$I_{ON} = 10\text{mA}$ to 30mA	—	6	12	Ω
ΔR_{ON}	Match Between Channels		—	0.4	2	
$R_{FLAT(ON)}$	R_{ON} Flatness	$I_{ON} = 1\text{mA}$, V_{NO} , $V_{NC} = 0V$ to $5V$	—	3	5	
$I_{NO(OFF)}$, $I_{NO(ON)}$	On/Off Leakage Current	V_{NO} , $V_{NC} = 4.5V$	-100	—	100	nA
I_{CC}	Quiescent Supply Current	$V_{CC} = 5.5V$, $V_{IN} = 0V$ or V_{CC}	—	—	1	μA
I_O	Output Current	V_{NO} , V_{NC} or $V_{COM} = 0V$ to $5V$	100	—	—	mA
V_{IH}	Input HIGH Voltage	Guaranteed Logic HIGH Level	2.0	—	—	V
V_{IL}	Input LOW Voltage	Guaranteed Logic LOW Level	-0.5	—	0.8	
I_{IH}	Input HIGH Current	$V_{CC} = \text{Max.}$, $V_{IN} = V_{CC}$	—	—	± 1	μA
I_{IL}	Input LOW Current	$V_{CC} = \text{Max.}$, $V_{IN} = GND$	—	—	± 1	

Dynamic Electrical Characteristics (Over the Operating Range, $T_A = -40^\circ\text{C}$ to $+85^\circ\text{C}$, $V_{CC} = 5V \pm 10\%$, $GND = 0V$)

Parameters	Description	Test Conditions ⁽¹⁾	Min.	Typ. ⁽²⁾	Max.	Units
t_{ON}	Turn-on Time	V_{ON} or $V_{NC} = 3.0V$, see Fig. 2	—	10	20	ns
t_{OFF}	Turn-off Time	V_{ON} or $V_{NC} = 3.0V$, see Fig. 2	—	5	10	
X_{TALK}	Crosstalk	$R_L = 100$ ohms, $f = 30$ MHz, see Fig. 4	—	-70	—	dB
$C_{(OFF)}$	NC or NO Capacitance	$f = 1$ kHz	—	13	—	pF
O_{IRR}	Off Isolation	$R_L = 100$ ohms, $f = 30$ MHz, see Fig. 5	—	-55	—	dB
BW	Bandwidth -3dB	$R_L = 100$ ohms, see Fig. 3	—	137	—	MHz
D	Distortion $DR_{ON/RL}$	$R_L = 100$ ohms	—	2	—	%

Note:

- For Max. or Min. conditions, use appropriate value specified under Electrical Characteristics for applicable device type.
- Guaranteed by design.

PI5L200

Single 3.3V Supply

DC Electrical Characteristics (Over the Operating Range, $T_A = -40^{\circ}\text{C}$ to $+85^{\circ}\text{C}$, $V_{CC} = 3.3\text{V} \pm 10\%$, $\text{GND} = 0\text{V}$)

Parameters	Description	Test Conditions ⁽¹⁾	Min.	Typ. ⁽²⁾	Max.	Units
V_{ANALOG}	Analog Signal Range		0	—	V_{CC}	V
R_{ON}	ON-Resistance	$I_{\text{ON}} = 10\text{mA}$ to 30mA	—	15	22	Ω
ΔR_{ON}	Match Between Channels		—	1	3	
$R_{\text{FLAT(ON)}}$	R_{ON} Flatness	$I_{\text{ON}} = 1\text{mA}$, V_{NO} , $V_{\text{NC}} = 0\text{V}$ to 5V	—	7	12	
$I_{\text{NO(OFF)}}$, $I_{\text{NO(ON)}}$	On/Off Leakage Current	V_{NO} , $V_{\text{NC}} = 3.0\text{V}$	-100	—	100	nA
$I_{\text{COM(ON)}}$	On Leakage Current	V_{NO} , $V_{\text{NC}} = 3.0\text{V}$	-100	—	100	μA
I_{O}	Output Current	V_{NO} , V_{NC} or $V_{\text{COM}} = 0\text{V}$	80	—	—	mA
V_{IH}	Input HIGH Voltage	Guaranteed Logic HIGH Level	2.0	—	—	V
V_{IL}	Input LOW Voltage	Guaranteed Logic LOW Level	-0.5	—	0.8	
I_{IH}	Input HIGH Current	$V_{CC} = \text{Max.}$, $V_{\text{IN}} = V_{CC}$	—	—	±1	μA
I_{IL}	Input LOW Current	$V_{CC} = \text{Max.}$, $V_{\text{IN}} = \text{GND}$	—	—	±1	

Dynamic Electrical Characteristics (Over the Operating Range, $T_A = -40^{\circ}\text{C}$ to $+85^{\circ}\text{C}$, $V_{CC} = 3.3\text{V} \pm 10\%$, $\text{GND} = 0\text{V}$)

Parameters	Description	Test Conditions ⁽¹⁾	Min.	Typ. ⁽²⁾	Max.	Units
t_{ON}	Turn-on Time	V_{ON} or $V_{\text{NC}} = 1.5\text{V}$, see Fig. 2	—	28	40	ns
t_{OFF}	Turn-off Time	V_{ON} or $V_{\text{NC}} = 1.5\text{V}$, see Fig. 2	—	4	20	
X_{TALK}	Crosstalk	$R_L = 50$ ohms, $f = 1$ MHz, see Fig. 4	—	-75	—	dB
$C_{\text{(OFF)}}$	NC or NO Capacitance	$f = 1$ kHz	—	15	—	pF
$C_{\text{COM(OFF)}}$	COM Off Capacitance	$f = 1$ kHz	—	30	—	
O_{IRR}	Off Isolation	$R_L = 50$ ohms, $f = 1$ MHz, see Fig. 5	—	-75	—	dB
BW	Bandwidth -3dB	$R_L = 50$ ohms, see Fig. 3	—	110	—	MHz
D	Distortion	$R_L = 100$ ohms	—	4	—	%

Dynamic Electrical Characteristics (Over the Operating Range, $T_A = -40^{\circ}\text{C}$ to $+85^{\circ}\text{C}$, $V_{CC} = 3.3\text{V} \pm 10\%$, $\text{GND} = 0\text{V}$)

Parameters	Description	Test Conditions ⁽¹⁾	Min.	Typ. ⁽²⁾	Max.	Units
I_{CC}	Quiescent Positive Power Supply Current	$V_{CC} = 3.6\text{V}$, $V_{\text{IN}} = 0\text{V}$ or V_{CC} All Channels ON or OFF	—	—	1	μA

Note:

- For Max. or Min. conditions, use appropriate value specified under Electrical Characteristics for applicable device type.
- Guaranteed by design.

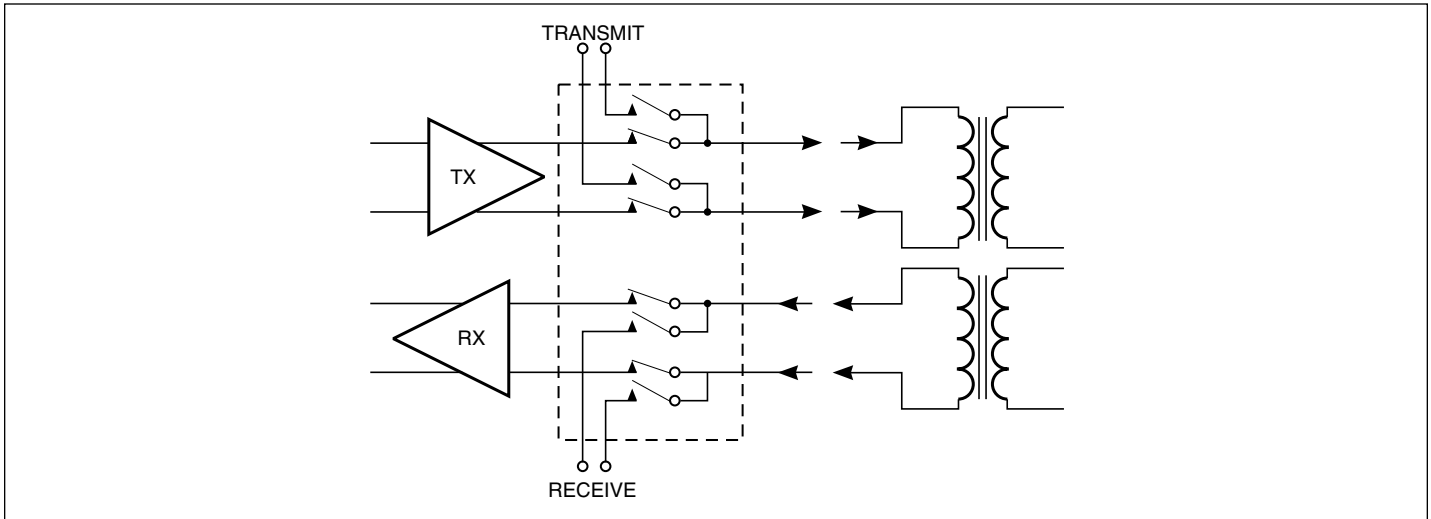

Figure 1a. Full Duplex Transceiver

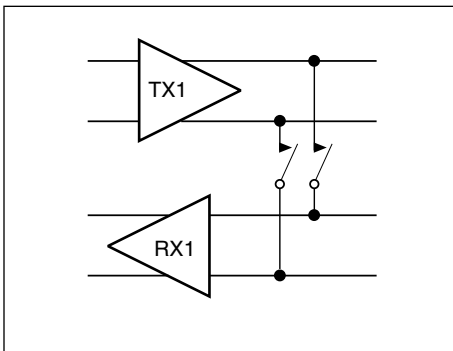

Figure 1b. Loop Back

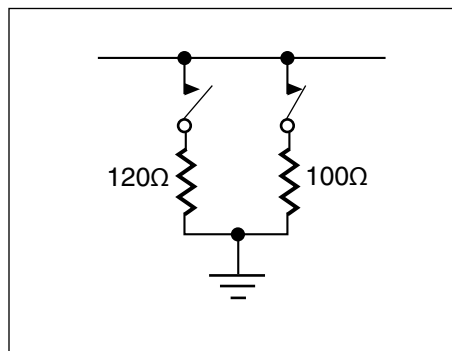

Figure 1c. Line Termination

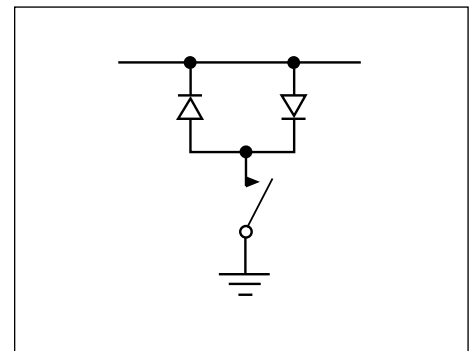

Figure 1d. Line Clamp

Test Circuits

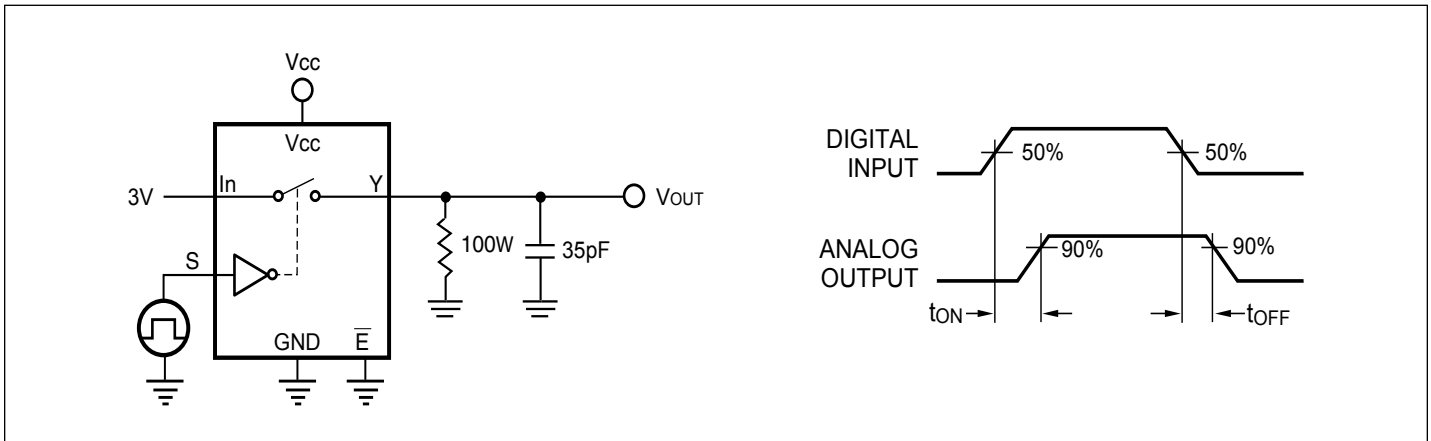

Figure 2. Switching Time

PI5L200

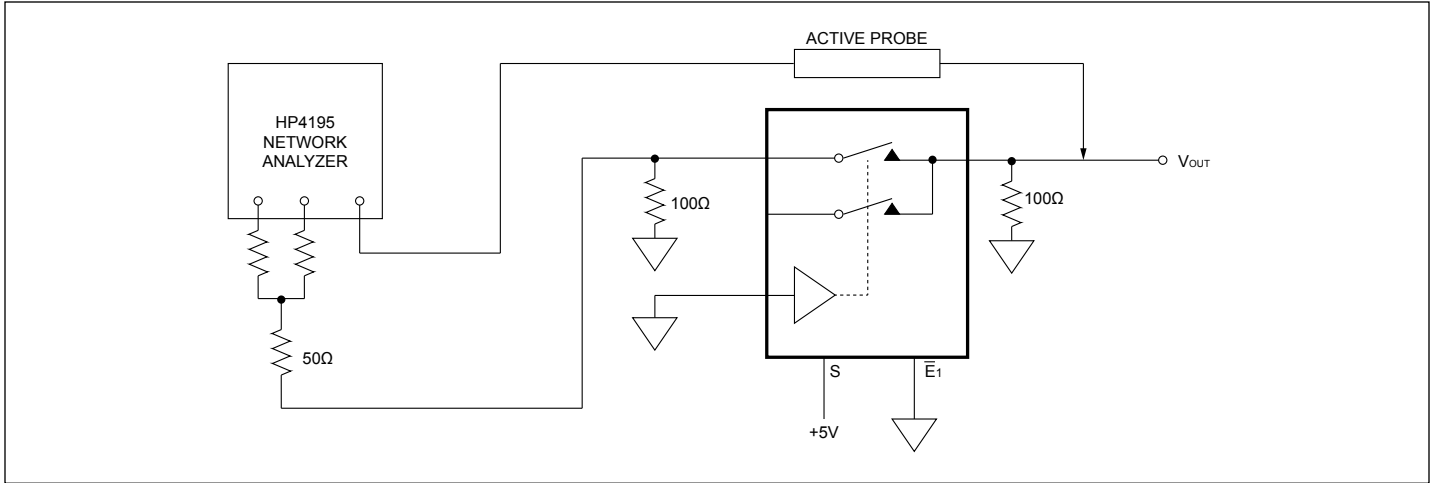

Figure 3. Bandwidth

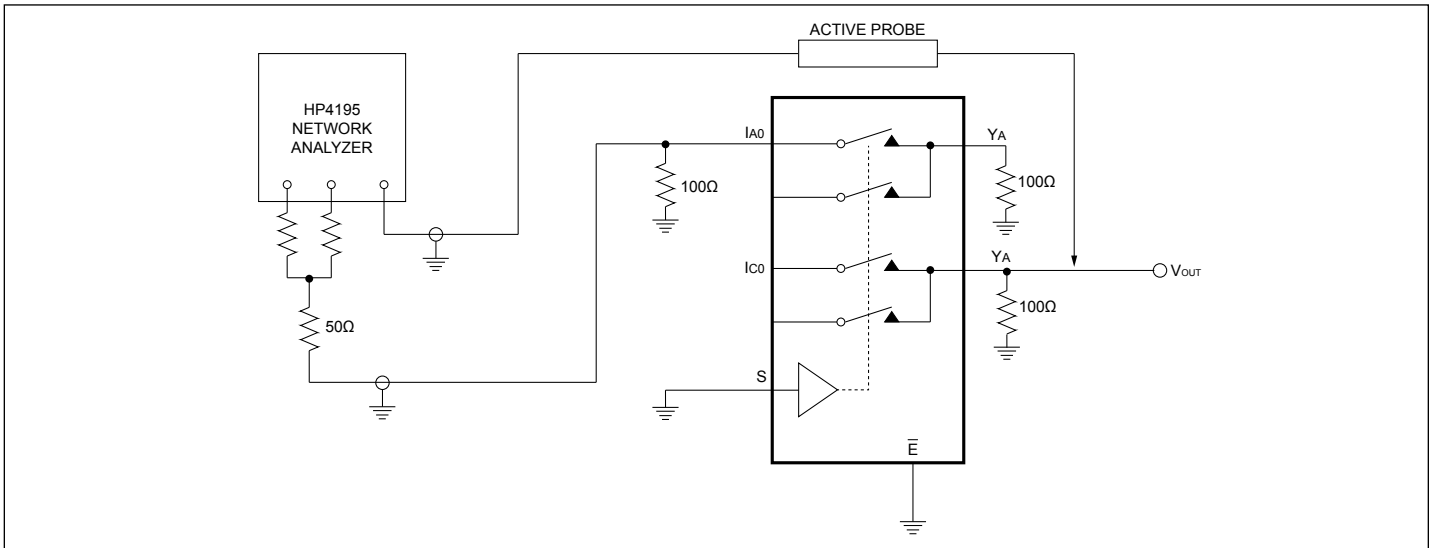

Figure 4. Crosstalk

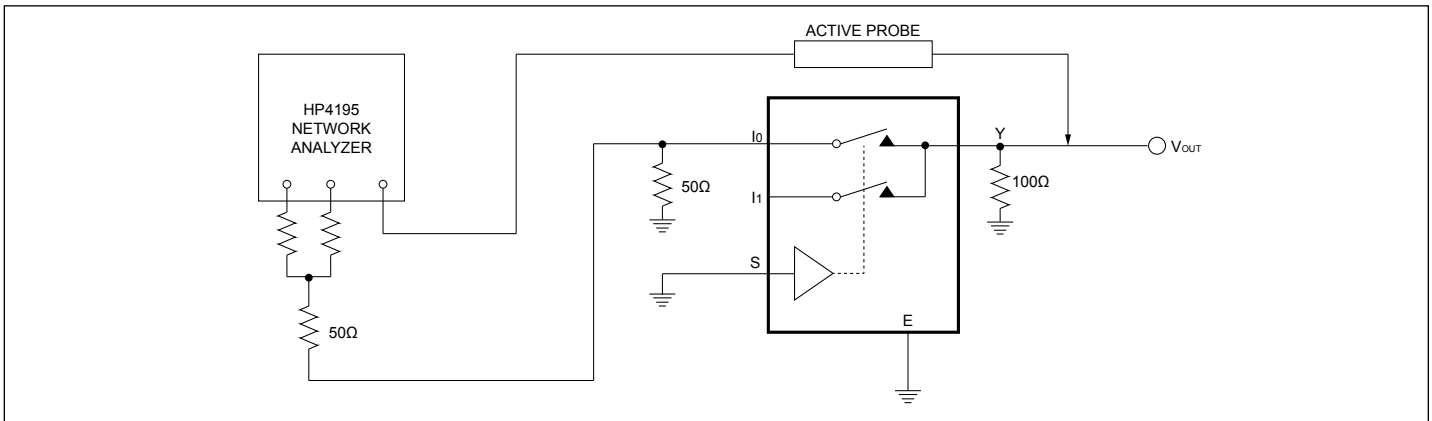

Figure 5. Off Isolation

PI5L200

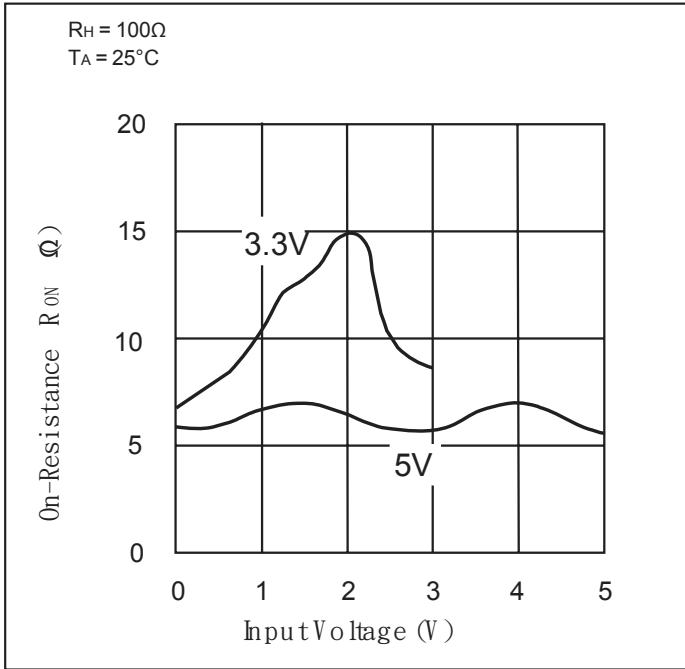

Figure 6. On-Resistance vs. Input Voltage

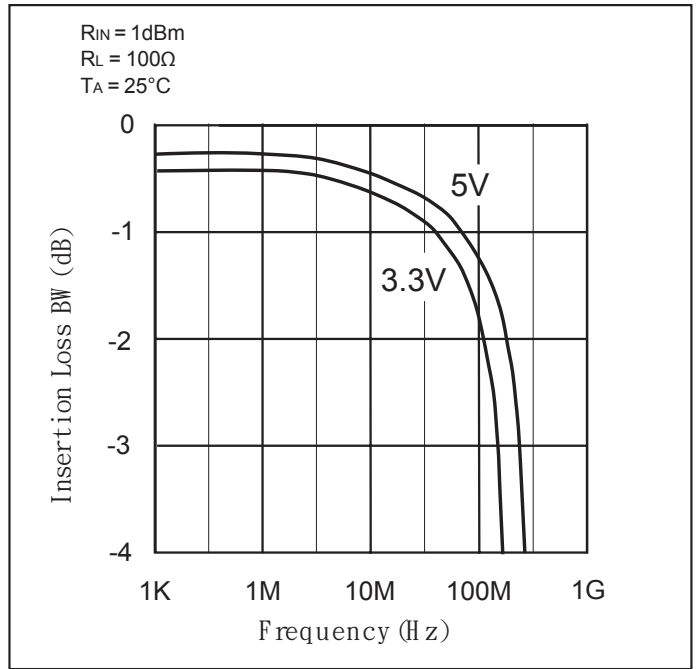

Figure 7. Insertion Loss vs. Frequency

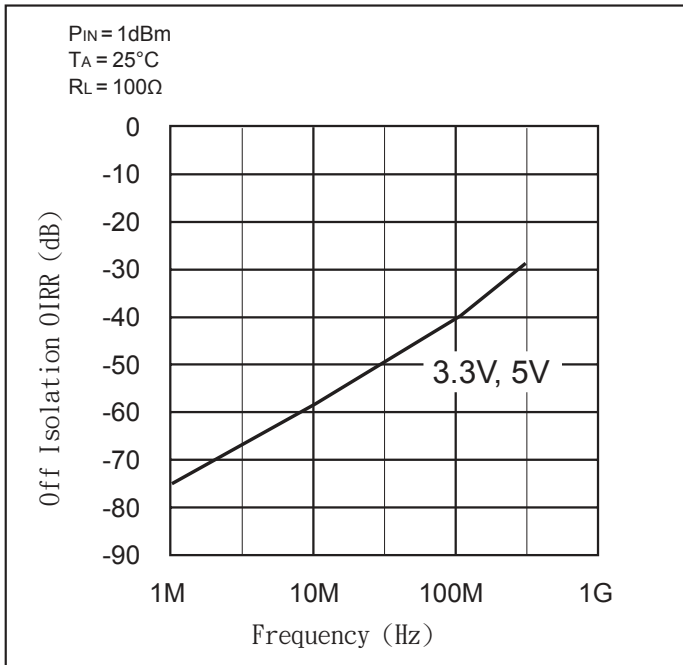

Figure 8. Off Isolation vs. Frequency

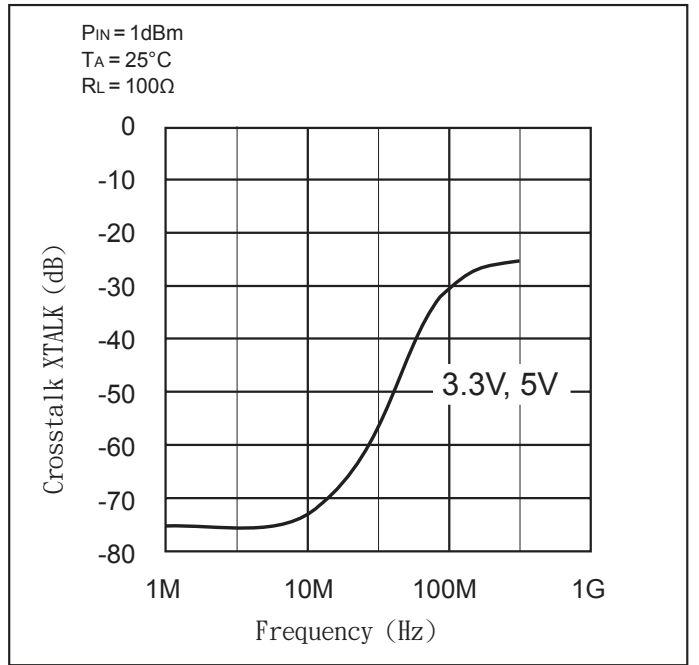

Figure 9. Crosstalk vs. Frequency

PI5L200

Part Marking

Q Package

PI5L
200QE
ZYWXX

Z: Die Rev Code
Y: Year
W: Workweek
1st X: Assembly Code
2nd X: Fab Code

W Package

 PI5L
200WE
BZYYWWXX

B: Port Code
Z: Die Rev
YY: Year
WW: Workweek
1st X: Assembly Code
2nd X: Fab Code

L Package

PI5L
200LE
ZYWXX

Z: Die Rev
Y: Year
W: Workweek
1st X: Assembly Code
2nd X: Fab Code

PI5L200

Packaging Mechanical: 16-QSOP (Q)

SYMBOLS	MIN.	NOM.	MAX.
A	—	—	0.069
A1	0.004	—	0.0098
A2	0.049	—	—
b	0.008	—	0.012
c	0.004	—	0.010
D	0.189	0.193	0.197
E1	0.150	0.154	0.158
E	0.228	0.236	0.244
L	0.016	—	0.050
L1	0.041 REF.		
e	0.025 BSC.		
θ°	0	—	8

UNIT : INCH

SEATING PLANE

GAUGE PLANE
SEATING PLANE

DETAIL A

PERICOM
Enabling Serial Connectivity

DATE: 04/08/16

DESCRIPTION: 16-Pin, 150mil Wide QSOP

PACKAGE CODE: Q (Q16)

DOCUMENT CONTROL #: PD-1201

REVISION: H

NOTES:
1. ALL DIMENSIONS IN INCH. ANGLES IN DEGREES.
2. JEDEC MO-137E
3. DIMENSIONS DOES NOT INCLUDE MOLD FLASH, PROTRUSIONS OR GATE BURRS.

16-0056

PI5L200

Packaging Mechanical: 16-SOIC (W)

SYMBOLS	MIN.	NOM.	MAX.
A	—	—	1.75
A1	0.10	—	0.25
A2	1.00	—	—
b	0.31	—	0.51
c	0.10	—	0.25
D	9.80	9.90	10.0
E	5.80	6.00	6.20
E1	3.80	3.90	4.00
e	1.27 BSC		
L	0.40	—	1.27
h	0.15	—	0.50
θ°	0	—	8

NOTES:
 1. ALL DIMENSIONS IN MILLIMETERS. ANGLES IN DEGREES.
 2. JEDEC OUTLINE : MS-012 AC
 3. DIMENSIONS DOES NOT INCLUDE MOLD FLASH, PROTRUSIONS OR GATE BURRS.
 4. THE MIN. DIMENSION OF A2 AND h ARE OUT OF JEDEC SPEC.

DIODES **PERICOM** A PRODUCT LINE OF DIODES INCORPORATED
 ENABLING SERIAL CONNECTIVITY

DATE: 06/30/16

DESCRIPTION: 16-Pin, 150mil Wide SOIC

PACKAGE CODE: W

DOCUMENT CONTROL #: PD-1004 **REVISION: G**

16-0145

PI5L200

Packaging Mechanical: 16-TSSOP (L)

SYMBOLS	MIN.	NOM.	MAX.
A	–	–	1.20
A1	0.05	–	0.15
A2	0.80	1.00	1.05
b	0.19	–	0.30
c	0.09	–	0.20
D	4.90	5.00	5.10
E1	4.30	4.40	4.50
E	6.20	6.40	6.60
[e]	0.65 BSC		
L1	1.00 REF		
L	0.45	0.60	0.75
S	0.20	–	–
θ	0°	–	8°

NOTES:
 1. ALL DIMENSIONS IN MILLIMETERS. ANGLES IN DEGREES.
 2. JEDEC MO-153F
 3. DIMENSIONS DOES NOT INCLUDE MOLD FLASH, PROTRUSIONS OR GATE BURRS.

		DATE: 03/24/16
DESCRIPTION: 16-Pin, 173mil Wide TSSOP		
PACKAGE CODE: L (L16)		
DOCUMENT CONTROL #: PD-1310	REVISION: G	

16-0061

For latest package info.

please check: <http://www.diodes.com/design/support/packaging/pericom-packaging/packaging-mechanicals-and-thermal-characteristics/>

Ordering Information

Ordering Code	Packaging Code	Package Description
PI5L200QEX	Q	16-pin, 150mil Wide (QSOP)
PI5L200WEX	W	16-pin, 150mil Wide (SOIC)
PI5L200LEX	L	16-pin, 173mil Wide (TSSOP)

Notes:

- EU Directive 2002/95/EC (RoHS), 2011/65/EU (RoHS 2) & 2015/863/EU (RoHS 3) compliant. All applicable RoHS exemptions applied.
- See <http://www.diodes.com/quality/lead-free/> for more information about Diodes Incorporated's definitions of Halogen- and Antimony-free, "Green" and Lead-free. Thermal characteristics can be found on the company web site at www.diodes.com/design/support/packaging/
- E = Pb-free and Green
- X suffix = Tape/Reel

IMPORTANT NOTICE

DIODES INCORPORATED MAKES NO WARRANTY OF ANY KIND, EXPRESS OR IMPLIED, WITH REGARDS TO THIS DOCUMENT, INCLUDING, BUT NOT LIMITED TO, THE IMPLIED WARRANTIES OF MERCHANTABILITY AND FITNESS FOR A PARTICULAR PURPOSE (AND THEIR EQUIVALENTS UNDER THE LAWS OF ANY JURISDICTION).

Diodes Incorporated and its subsidiaries reserve the right to make modifications, enhancements, improvements, corrections or other changes without further notice to this document and any product described herein. Diodes Incorporated does not assume any liability arising out of the application or use of this document or any product described herein; neither does Diodes Incorporated convey any license under its patent or trademark rights, nor the rights of others. Any Customer or user of this document or products described herein in such applications shall assume all risks of such use and will agree to hold Diodes Incorporated and all the companies whose products are represented on Diodes Incorporated website, harmless against all damages.

Diodes Incorporated does not warrant or accept any liability whatsoever in respect of any products purchased through unauthorized sales channel.

Should Customers purchase or use Diodes Incorporated products for any unintended or unauthorized application, Customers shall indemnify and hold Diodes Incorporated and its representatives harmless against all claims, damages, expenses, and attorney fees arising out of, directly or indirectly, any claim of personal injury or death associated with such unintended or unauthorized application.

Products described herein may be covered by one or more United States, international or foreign patents pending. Product names and markings noted herein may also be covered by one or more United States, international or foreign trademarks.

This document is written in English but may be translated into multiple languages for reference. Only the English version of this document is the final and determinative format released by Diodes Incorporated.

LIFE SUPPORT

Diodes Incorporated products are specifically not authorized for use as critical components in life support devices or systems without the express written approval of the Chief Executive Officer of Diodes Incorporated. As used herein:

A. Life support devices or systems are devices or systems which:

1. are intended to implant into the body, or

2. support or sustain life and whose failure to perform when properly used in accordance with instructions for use provided in the labeling can be reasonably expected to result in significant injury to the user.

B. A critical component is any component in a life support device or system whose failure to perform can be reasonably expected to cause the failure of the life support device or to affect its safety or effectiveness.

Customers represent that they have all necessary expertise in the safety and regulatory ramifications of their life support devices or systems, and acknowledge and agree that they are solely responsible for all legal, regulatory and safety-related requirements concerning their products and any use of Diodes Incorporated products in such safety-critical, life support devices or systems, notwithstanding any devices- or systems-related information or support that may be provided by Diodes Incorporated. Further, Customers must fully indemnify Diodes Incorporated and its representatives against any damages arising out of the use of Diodes Incorporated products in such safety-critical, life support devices or systems.

Copyright © 2016, Diodes Incorporated
www.diodes.com

Looking for pricing, stock, or lifecycle information?

Click below to explore more details on WIN SOURCE:

-  [View PI5L200LE on WIN SOURCE](#)
-  [Diodes Incorporated Information](#)

Optimize Your Supply Chain with WIN SOURCE Solutions

-  Global Sourcing Solution
-  Obsolete Management
-  Cost Control Management
-  Shortage Management
-  Alternative Solution
-  Excess Inventory Management