



THE DATASHEET OF DRV8824QPWPRQ1



DRV8824-Q1 Automotive Motor Controller IC

1 Features

- Qualified for Automotive Applications
- AEC-Q100 Qualified with the Following Results:
 - Device Temperature Grade 1: -40°C to +125°C
 - Device HBM ESD Classification Level H2
 - Device CDM ESD Classification Level C4B
- PWM Microstepping Motor Driver
 - Built-In Microstepping Indexer
 - Five-Bit Winding Current Control Allows Up to 32 Current Levels
 - Low MOSFET On-Resistance
- 1.6-A Maximum Drive Current at 24 V, 25°C
- Built-In 3.3-V Reference Output
- 8.2-V to 45-V Operating Supply Voltage Range
- Thermally Enhanced HTSSOP Surface Mount Package

2 Applications

- Automotive HVAC
- Automotive Valves
- Automotive Infotainment

4 Simplified Schematic

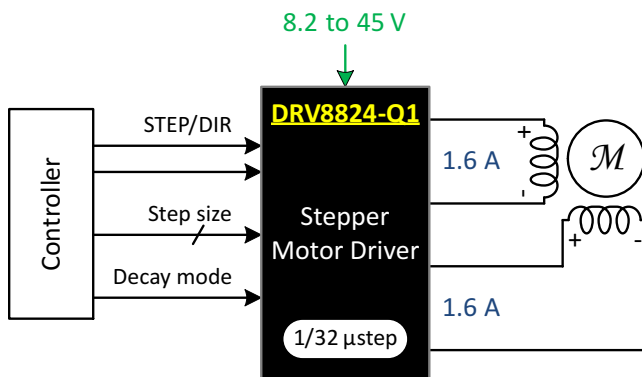

3 Description

The DRV8824-Q1 provides an integrated motor driver solution for automotive applications. The device has two H-bridge drivers and a microstepping indexer, and is intended to drive a bipolar stepper motor. The output driver block for each consists of N-channel power MOSFET's configured as full H-bridges to drive the motor windings. The DRV8824-Q1 is capable of driving up to 1.6-A of output current (with proper heatsinking, at 24 V and 25°C).

A simple step/direction interface allows easy interfacing to controller circuits. Terminals allow configuration of the motor in full-step up to 1/32-step modes. Decay mode is programmable.

Internal shutdown functions are provided for overcurrent protection, short circuit protection, undervoltage lockout and overtemperature.

The DRV8824-Q1 is available in a 28-terminal HTSSOP package with PowerPAD™ (Eco-friendly: RoHS & no Sb/Br).

Device Information

ORDER NUMBER	PACKAGE	BODY SIZE
DRV8824QPWPRQ1	HTSSOP (28)	9.7 mm x 4.4 mm

Microstepping Current Waveform

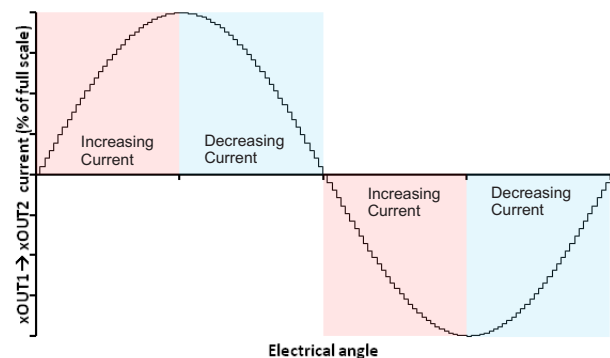

Table of Contents

1 Features	1	8.2 Functional Block Diagram	10
2 Applications	1	8.3 Feature Description	11
3 Description	1	8.4 Device Functional Modes	17
4 Simplified Schematic	1	9 Application and Implementation	18
5 Revision History	2	9.1 Application Information	18
6 Terminal Configuration and Functions	3	9.2 Typical Application	18
7 Specifications	4	10 Power Supply Recommendations	20
7.1 Absolute Maximum Ratings	4	11 Layout	21
7.2 Handling Ratings	4	11.1 Layout Guidelines	21
7.3 Recommended Operating Conditions	4	11.2 Layout Example	21
7.4 Thermal Information	5	12 Device and Documentation Support	22
7.5 Electrical Characteristics	5	12.1 Trademarks	22
7.6 Timing Requirements	6	12.2 Electrostatic Discharge Caution	22
7.7 Typical Characteristics	8	12.3 Glossary	22
8 Detailed Description	9	13 Mechanical, Packaging, and Orderable Information	22
8.1 Overview	9		

5 Revision History

DATE	REVISION	NOTES
April 2014	*	Initial release.

6 Terminal Configuration and Functions

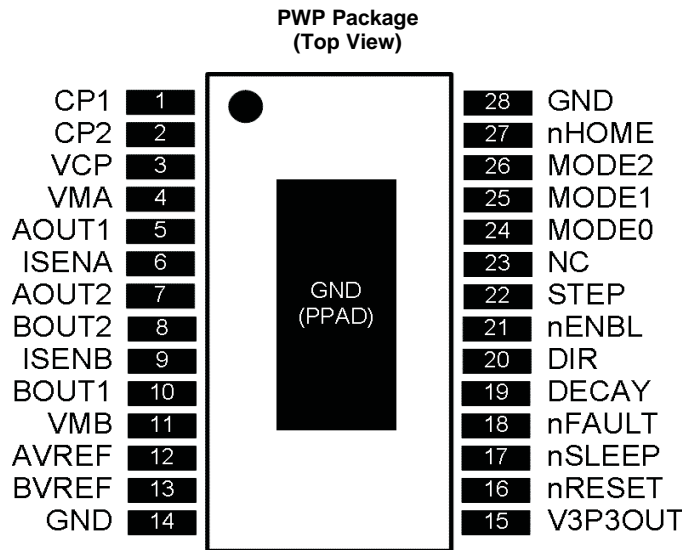

Terminal Functions

NAME	TERMINAL	I/O	DESCRIPTION	EXTERNAL COMPONENTS OR CONNECTIONS
POWER AND GROUND				
GND	14, 28	-	Device ground	
VMA	4	-	Bridge A power supply	Connect to motor supply (8.2 V - 45 V). Both terminals must be connected to same supply.
VMB	11	-	Bridge B power supply	
V3P3OUT	15	O	3.3-V regulator output	Bypass to GND with a 0.47- μ F 6.3-V ceramic capacitor. Can be used to supply VREF.
CP1	1	IO	Charge pump flying capacitor	Connect a 0.01- μ F 50-V capacitor between CP1 and CP2.
CP2	2	IO	Charge pump flying capacitor	
VCP	3	IO	High-side gate drive voltage	Connect a 0.1- μ F 16-V ceramic capacitor and a 1-M Ω resistor to VM.
CONTROL				
nENBL	21	I	Enable input	Logic high to disable device outputs and indexer operation, logic low to enable. Internal pulldown.
nSLEEP	17	I	Sleep mode input	Logic high to enable device, logic low to enter low-power sleep mode. Internal pulldown.
STEP	22	I	Step input	Rising edge causes the indexer to move one step. Internal pulldown.
DIR	20	I	Direction input	Level sets the direction of stepping. Internal pulldown.
MODE0	24	I	Microstep mode 0	MODE0 - MODE2 set the step mode - full, 1/2, 1/4, 1/8/ 1/16, or 1/32 step. Internal pulldown.
MODE1	25	I	Microstep mode 1	
MODE2	26	I	Microstep mode 2	
DECAY	19	I	Decay mode	Low = slow decay, open = mixed decay, high = fast decay. Internal pulldown and pullup.
nRESET	16	I	Reset input	Active-low reset input initializes the indexer logic and disables the H-bridge outputs. Internal pulldown.
AVREF	12	I	Bridge A current set reference input	Reference voltage for winding current set. Normally AVREF and BVREF are connected to the same voltage. Can be connected to V3P3OUT. A 0.01- μ F bypass capacitor to GND is recommended.
BVREF	13	I	Bridge B current set reference input	
NC	23		No connect	Leave this terminal unconnected.
STATUS				
nHOME	27	OD	Home position	Logic low when at home state of step table
nFAULT	18	OD	Fault	Logic low when in fault condition (overtemp, overcurrent)

Terminal Functions (continued)

NAME	TERMINAL	I/O	DESCRIPTION	EXTERNAL COMPONENTS OR CONNECTIONS
OUTPUT				
ISENA	6	IO	Bridge A ground / Isense	Connect to current sense resistor for bridge A.
ISENB	9	IO	Bridge B ground / Isense	Connect to current sense resistor for bridge B.
AOUT1	5	O	Bridge A output 1	Connect to bipolar stepper motor winding A. Positive current is AOUT1 → AOUT2
AOUT2	7	O	Bridge A output 2	
BOUT1	10	O	Bridge B output 1	Connect to bipolar stepper motor winding B. Positive current is BOUT1 → BOUT2
BOUT2	8	O	Bridge B output 2	

7 Specifications

7.1 Absolute Maximum Ratings

 over operating free-air temperature range (unless otherwise noted) ⁽¹⁾⁽²⁾

		VALUE	UNIT
VMx	Power supply voltage range	–0.3 to 47	V
	Digital terminal voltage range	–0.5 to 7	V
VREF	Input voltage	–0.3 to 4	V
	ISENSEx terminal voltage	–0.3 to 0.8	V
	Peak motor drive output current, $t < 1 \mu\text{S}$	Internally limited	A
	Continuous motor drive output current ⁽³⁾	1.6	A
	Continuous total power dissipation	See Thermal Information table	
T _J	Operating virtual junction temperature range	–40 to 150	°C

- (1) Stresses beyond those listed under absolute maximum ratings may cause permanent damage to the device. These are stress ratings only, and functional operation of the device at these or any other conditions beyond those indicated under recommended operating conditions is not implied. Exposure to absolute maximum rated conditions for extended periods may affect device reliability.
- (2) All voltage values are with respect to network ground terminal.
- (3) Power dissipation and thermal limits must be observed.

7.2 Handling Ratings

		MIN	MAX	UNIT
T _{stg}	Storage temperature range	–60	150	°C
V _{ESD}	HBD (human body model), AEC-Q100 Classification H2		2000	V
	CDM (charged device model), AEC-Q100 Classification C4B		750	

7.3 Recommended Operating Conditions

		MIN	NOM	MAX	UNIT
V _M	Motor power supply voltage ⁽¹⁾	8.2		45	V
V _{REF}	VREF input voltage ⁽²⁾	1		3.5	V
I _{V3P3}	V3P3OUT load current			1	mA

- (1) All V_M terminals must be connected to the same supply voltage.
- (2) Operational at VREF between 0 V and 1 V, but accuracy is degraded.

7.4 Thermal Information

THERMAL METRIC		DRV8824-Q1	UNIT
		PWP	
		28 TERMINAL	
$R_{\theta JA}$	Junction-to-ambient thermal resistance ⁽¹⁾	38.9	°C/W
$R_{\theta JC(top)}$	Junction-to-case (top) thermal resistance ⁽²⁾	23.3	
$R_{\theta JB}$	Junction-to-board thermal resistance ⁽³⁾	21.2	
ψ_{JT}	Junction-to-top characterization parameter ⁽⁴⁾	0.8	
ψ_{JB}	Junction-to-board characterization parameter ⁽⁵⁾	20.9	
$R_{\theta JC(bot)}$	Junction-to-case (bottom) thermal resistance ⁽⁶⁾	2.6	

- (1) The junction-to-ambient thermal resistance under natural convection is obtained in a simulation on a JEDEC-standard, high-K board, as specified in JESD51-7, in an environment described in JESD51-2a.
- (2) The junction-to-case (top) thermal resistance is obtained by simulating a cold plate test on the package top. No specific JEDEC-standard test exists, but a close description can be found in the ANSI SEMI standard G30-88.
- (3) The junction-to-board thermal resistance is obtained by simulating in an environment with a ring cold plate fixture to control the PCB temperature, as described in JESD51-8.
- (4) The junction-to-top characterization parameter, ψ_{JT} , estimates the junction temperature of a device in a real system and is extracted from the simulation data for obtaining θ_{JA} , using a procedure described in JESD51-2a (sections 6 and 7).
- (5) The junction-to-board characterization parameter, ψ_{JB} , estimates the junction temperature of a device in a real system and is extracted from the simulation data for obtaining θ_{JA} , using a procedure described in JESD51-2a (sections 6 and 7).
- (6) The junction-to-case (bottom) thermal resistance is obtained by simulating a cold plate test on the exposed (power) pad. No specific JEDEC standard test exists, but a close description can be found in the ANSI SEMI standard G30-88.

7.5 Electrical Characteristics

over operating free-air temperature range of -40°C to 125°C (unless otherwise noted)

PARAMETER		TEST CONDITIONS	MIN	TYP	MAX	UNIT
POWER SUPPLIES						
I_{VM}	VM operating supply current	$V_M = 24\text{ V}$, $f_{PWM} < 50\text{ kHz}$		5	8	mA
I_{VMQ}	VM sleep mode supply current	$V_M = 24\text{ V}$		10	20	µA
V_{UVLO}	VM undervoltage lockout voltage	V_M rising		7.8	8.2	V
V3P3OUT REGULATOR						
V_{3P3}	V3P3OUT voltage	$I_{OUT} = 0$ to 1 mA, $V_M = 24\text{ V}$, $T_J = 25^\circ\text{C}$	3.18	3.30	3.45	V
		$I_{OUT} = 0$ to 1 mA	3.10	3.30	3.50	
LOGIC-LEVEL INPUTS						
V_{IL}	Input low voltage			0.6	0.7	V
V_{IH}	Input high voltage		2		5.25	V
V_{HYS}	Input hysteresis			0.45		V
I_{iL}	Input low current	$V_{IN} = 0$	-20		20	µA
I_{iH}	Input high current	$V_{IN} = 3.3\text{ V}$			100	µA
R_{PD}	Internal pulldown resistance	nENBL, nRESET, DIR, STEP, MODEx		100		kΩ
		nSLEEP		1		MΩ
nHOME, nFAULT OUTPUTS (OPEN-DRAIN OUTPUTS)						
V_{OL}	Output low voltage	$I_O = 5\text{ mA}$			0.5	V
I_{OH}	Output high leakage current	$V_O = 3.3\text{ V}$			1	µA
DECAY INPUT						
V_{iL}	Input low threshold voltage	For slow decay mode			0.8	V
V_{iH}	Input high threshold voltage	For fast decay mode	2			V
I_{iN}	Input current		-100		100	µA
R_{PU}	Internal pullup resistance			130		kΩ
R_{PD}	Internal pulldown resistance			80		kΩ

Electrical Characteristics (continued)

over operating free-air temperature range of -40°C to 125°C (unless otherwise noted)

PARAMETER		TEST CONDITIONS	MIN	TYP	MAX	UNIT
H-BRIDGE FETS						
R _{DS(ON)}	HS FET on resistance	V _M = 24 V, I _O = 1 A, T _J = 25°C		0.63		Ω
		V _M = 24 V, I _O = 1 A, T _J = 85°C		0.76	0.90	
		V _M = 24 V, I _O = 1 A, T _J = 125°C		0.85	1	
R _{DS(ON)}	LS FET on resistance	V _M = 24 V, I _O = 1 A, T _J = 25°C		0.65		Ω
		V _M = 24 V, I _O = 1 A, T _J = 85°C		0.78	0.90	
		V _M = 24 V, I _O = 1 A, T _J = 125°C		0.85	1	
I _{OFF}	Off-state leakage current		-20		20	μA
MOTOR DRIVER						
f _{PWM}	Internal PWM frequency			50		kHz
t _{BLANK}	Current sense blanking time			3.75		μs
t _R	Rise time	V _M = 24 V	100		360	ns
t _F	Fall time	V _M = 24 V	80		250	ns
t _{DEAD}	Dead time			400		ns
PROTECTION CIRCUITS						
I _{OC}	Overcurrent protection trip level		1.8		5	A
t _{SD}	Thermal shutdown temperature	Die temperature	150	160	180	°C
CURRENT CONTROL						
I _{REF}	xVREF input current	xVREF = 3.3 V	-3		3	μA
V _{TRIP}	xISENSE trip voltage	xVREF = 3.3 V, 100% current setting	635	660	685	mV
ΔI _{TRIP}	Current trip accuracy (relative to programmed value)	xVREF = 3.3 V, 5% current setting	-25%		25%	
		xVREF = 3.3 V, 10% - 34% current setting	-15%		15%	
		xVREF = 3.3 V, 38% - 67% current setting	-10%		10%	
		xVREF = 3.3 V, 71% - 100% current setting	-5%		5%	
A _{ISENSE}	Current sense amplifier gain	Reference only		5		V/V

7.6 Timing Requirements

			MIN	MAX	UNIT
1	f _{STEP}	Step frequency		250	kHz
2	t _{WH(STEP)}	Pulse duration, STEP high	1.9		μs
3	t _{WL(STEP)}	Pulse duration, STEP low	1.9		μs
4	t _{SU(STEP)}	Setup time, command to STEP rising	200		ns
5	t _{H(STEP)}	Hold time, command to STEP rising	200		ns
6	t _{ENBL}	Enable time, nENBL active to STEP	200		ns
7	t _{WAKE}	Wakeup time, nSLEEP inactive to STEP	1		ms

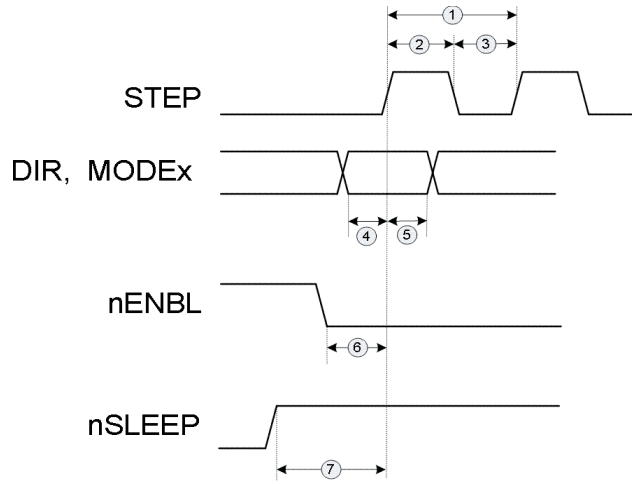

Figure 1. Timing Diagram

7.7 Typical Characteristics

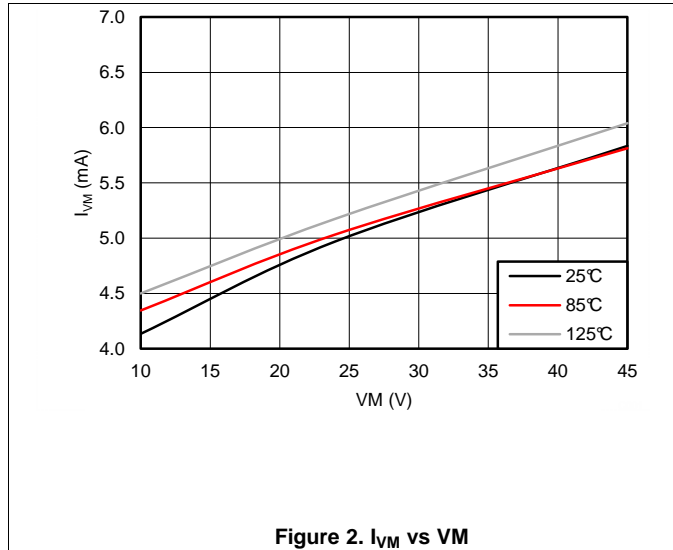

Figure 2. I_{VM} vs VM

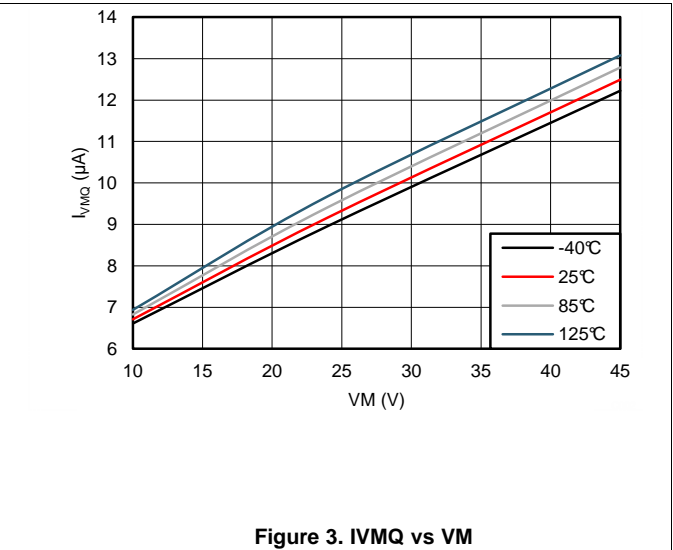

Figure 3. I_{VMQ} vs VM

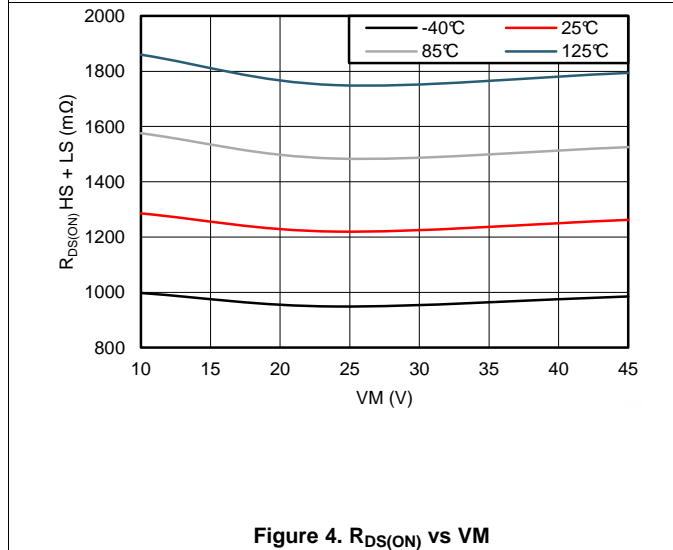

Figure 4. R_{DS(ON)} vs VM

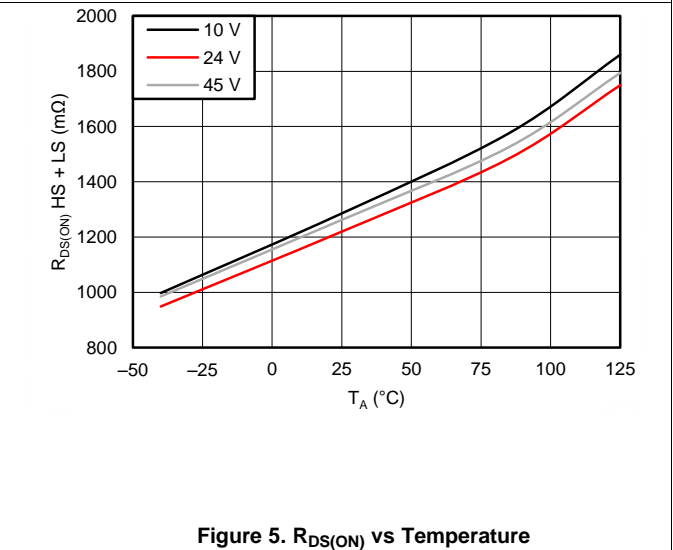

Figure 5. R_{DS(ON)} vs Temperature

8 Detailed Description

8.1 Overview

The DRV8824-Q1 is an integrated motor driver solution for bipolar stepper motors. The device integrates two NMOS H-bridges, current sense and regulation circuitry, and a microstepping indexer. The DRV8824-Q1 can be powered with a supply voltage between 8.2 V and 45 V, and is capable of providing an output current up to 1.6 A full-scale or 1.1 A rms.

A simple STEP/DIR interface allows easy interfacing to the controller circuit. The internal indexer is able to execute high-accuracy microstepping without requiring the processor to control the current level.

The current regulation is highly configurable, with three decay modes of operation. Fast, slow, and mixed decay can be used.

A low-power sleep mode is included which allows the system to save power when not driving the motor.

8.2 Functional Block Diagram

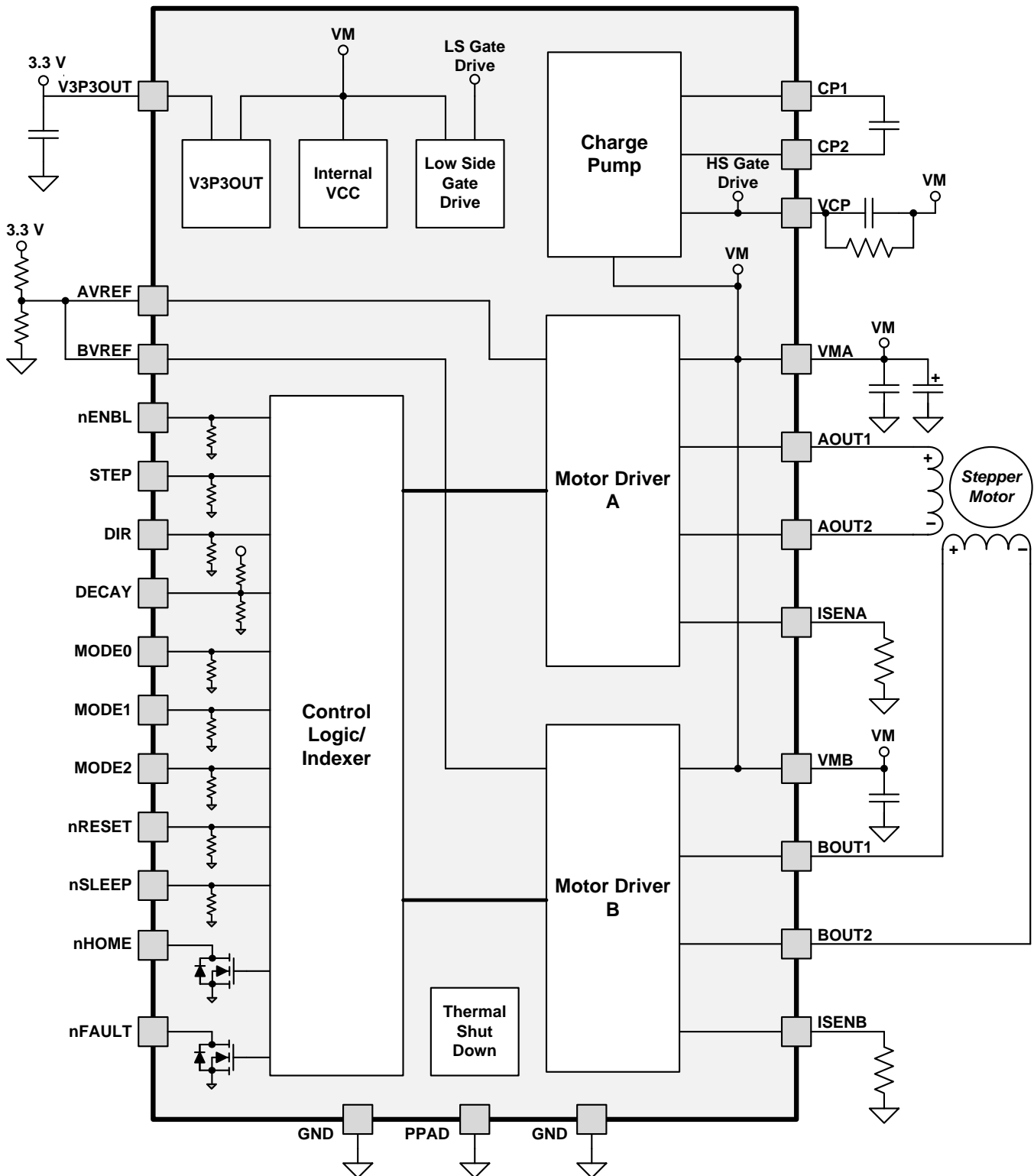

8.3 Feature Description

8.3.1 PWM Motor Drivers

The DRV8824-Q1 contains two H-bridge motor drivers with current-control PWM circuitry. A block diagram of the motor control circuitry is shown in Figure 6.

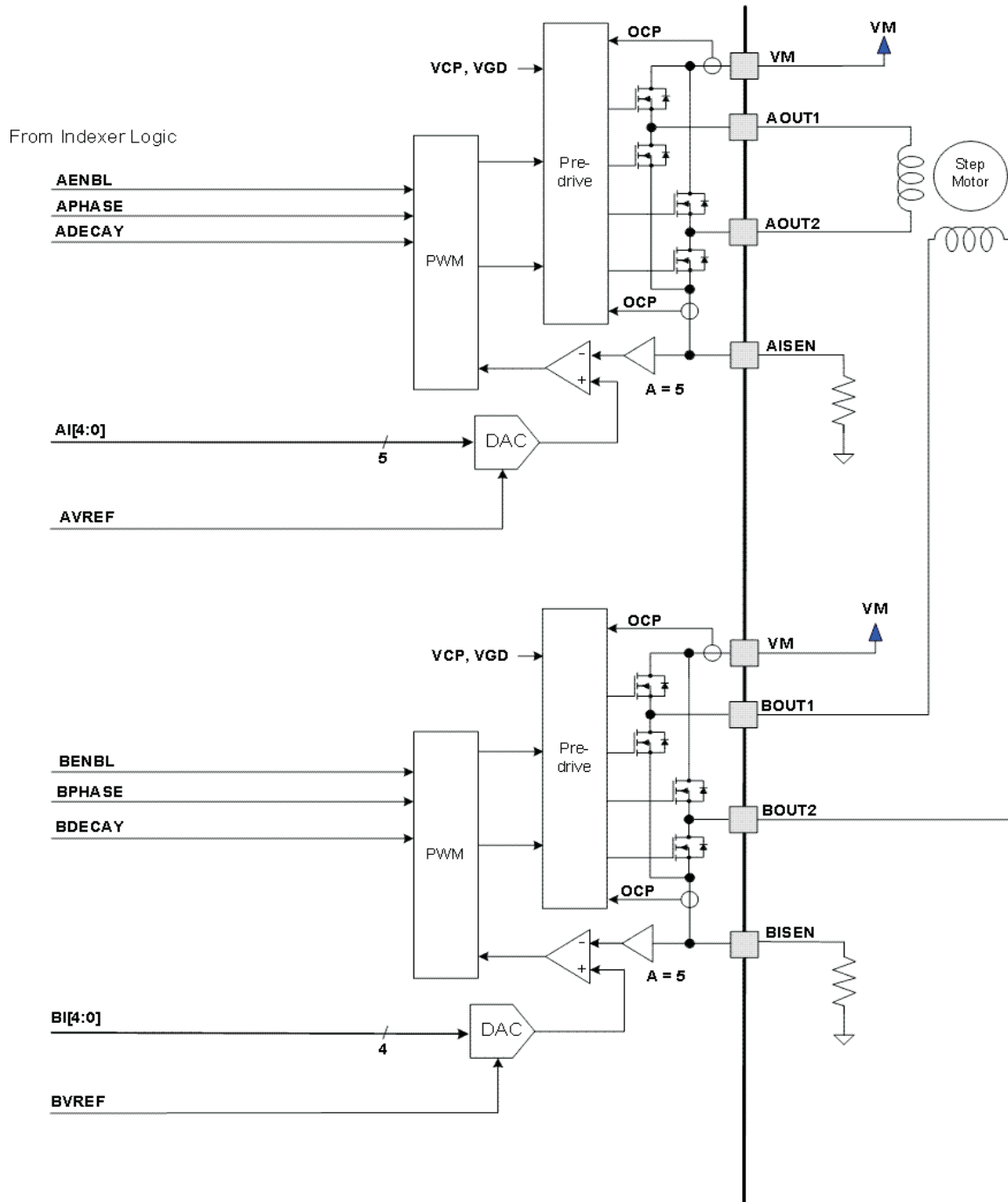

Figure 6. Motor Control Circuitry

Note that there are multiple VM motor power supply terminals. All VM terminals must be connected together to the motor supply voltage.

Feature Description (continued)

8.3.2 Current Regulation

The current through the motor windings is regulated by a fixed-frequency PWM current regulation, or current chopping. When an H-bridge is enabled, current rises through the winding at a rate dependent on the DC voltage and inductance of the winding. Once the current hits the current chopping threshold, the bridge disables the current until the beginning of the next PWM cycle.

In stepping motors, current regulation is used to vary the current in the two windings in a semi-sinusoidal fashion to provide smooth motion.

The PWM chopping current is set by a comparator which compares the voltage across a current sense resistor connected to the xISEN terminals, multiplied by a factor of 5, with a reference voltage. The reference voltage is input from the xVREF terminals.

The full-scale (100%) chopping current is calculated in [Equation 1](#).

$$I_{CHOP} = \frac{V_{REFX}}{5 \cdot R_{ISENSE}} \quad (1)$$

Example:

If a 0.5-Ω sense resistor is used and the VREFx terminal is 3.3 V, the full-scale (100%) chopping current will be 3.3 V / (5 x 0.5 Ω) = 1.32 A.

The reference voltage is scaled by an internal DAC that allows fractional stepping of a bipolar stepper motor, as described in the microstepping indexer section below.

8.3.3 Blanking Time

After the current is enabled in an H-bridge, the voltage on the xISEN terminal is ignored for a fixed period of time before enabling the current sense circuitry. This blanking time is fixed at 3.75 μs. Note that the blanking time also sets the minimum on time of the PWM.

8.3.4 Microstepping Indexer

Built-in indexer logic in the DRV8824-Q1 allows a number of different stepping configurations. The MODE0 - MODE2 terminals are used to configure the stepping format as shown in .

Table 1. Stepping Format

MODE2	MODE1	MODE0	STEP MODE
0	0	0	Full step (2-phase excitation) with 71% current
0	0	1	1/2 step (1-2 phase excitation)
0	1	0	1/4 step (W1-2 phase excitation)
0	1	1	8 microsteps / step
1	0	0	16 microsteps / step
1	0	1	32 microsteps / step
1	1	0	32 microsteps / step
1	1	1	32 microsteps / step

[Table 2](#) shows the relative current and step directions for different settings of MODEx. At each rising edge of the STEP input, the indexer travels to the next state in the table. The direction is shown with the DIR terminal high; if the DIR terminal is low the sequence is reversed. Positive current is defined as xOUT1 = positive with respect to xOUT2.

Note that if the step mode is changed while stepping, the indexer will advance to the next valid state for the new MODEx setting at the rising edge of STEP.

The home state is 45°. This state is entered at power-up or application of nRESET. This is shown in [Table 2](#) by the shaded cells. The logic inputs DIR, STEP, nRESET and MODEx have an internal pulldown resistors of 100 kΩ

Table 2. Relative Current and Step Directions

1/32 STEP	1/16 STEP	1/8 STEP	1/4 STEP	1/2 STEP	FULL STEP 70%	WINDING CURRENT A	WINDING CURRENT B	ELECTRICAL ANGLE
1	1	1	1	1		100%	0%	0
2						100%	5%	3
3	2					100%	10%	6
4						99%	15%	8
5	3	2				98%	20%	11
6						97%	24%	14
7	4					96%	29%	17
8						94%	34%	20
9	5	3	2			92%	38%	23
10						90%	43%	25
11	6					88%	47%	28
12						86%	51%	31
13	7	4				83%	56%	34
14						80%	60%	37
15	8					77%	63%	39
16						74%	67%	42
17	9	5	3	2	1	71%	71%	45
18						67%	74%	48
19	10					63%	77%	51
20						60%	80%	53
21	11	6				56%	83%	56
22						51%	86%	59
23	12					47%	88%	62
24						43%	90%	65
25	13	7	4			38%	92%	68
26						34%	94%	70
27	14					29%	96%	73
28						24%	97%	76
29	15	8				20%	98%	79
30						15%	99%	82
31	16					10%	100%	84
32						5%	100%	87
33	17	9	5	3		0%	100%	90
34						-5%	100%	93
35	18					-10%	100%	96
36						-15%	99%	98
37	19	10				-20%	98%	101
38						-24%	97%	104
39	20					-29%	96%	107
40						-34%	94%	110
41	21	11	6			-38%	92%	113
42						-43%	90%	115
43	22					-47%	88%	118
44						-51%	86%	121
45	23	12				-56%	83%	124
46						-60%	80%	127

Table 2. Relative Current and Step Directions (continued)

1/32 STEP	1/16 STEP	1/8 STEP	1/4 STEP	1/2 STEP	FULL STEP 70%	WINDING CURRENT A	WINDING CURRENT B	ELECTRICAL ANGLE
47	24					-63%	77%	129
48						-67%	74%	132
49	25	13	7	4	2	-71%	71%	135
50						-74%	67%	138
51	26					-77%	63%	141
52						-80%	60%	143
53	27	14				-83%	56%	146
54						-86%	51%	149
55	28					-88%	47%	152
56						-90%	43%	155
57	29	15	8			-92%	38%	158
58						-94%	34%	160
59	30					-96%	29%	163
60						-97%	24%	166
61	31	16				-98%	20%	169
62						-99%	15%	172
63	32					-100%	10%	174
64						-100%	5%	177
65	33	17	9	5		-100%	0%	180
66						-100%	-5%	183
67	34					-100%	-10%	186
68						-99%	-15%	188
69	35	18				-98%	-20%	191
70						-97%	-24%	194
71	36					-96%	-29%	197
72						-94%	-34%	200
73	37	19	10			-92%	-38%	203
74						-90%	-43%	205
75	38					-88%	-47%	208
76						-86%	-51%	211
77	39	20				-83%	-56%	214
78						-80%	-60%	217
79	40					-77%	-63%	219
80						-74%	-67%	222
81	41	21	11	6	3	-71%	-71%	225
82						-67%	-74%	228
83	42					-63%	-77%	231
84						-60%	-80%	233
85	43	22				-56%	-83%	236
86						-51%	-86%	239
87	44					-47%	-88%	242
88						-43%	-90%	245
89	45	23	12			-38%	-92%	248
90						-34%	-94%	250
91	46					-29%	-96%	253
92						-24%	-97%	256

Table 2. Relative Current and Step Directions (continued)

1/32 STEP	1/16 STEP	1/8 STEP	1/4 STEP	1/2 STEP	FULL STEP 70%	WINDING CURRENT A	WINDING CURRENT B	ELECTRICAL ANGLE
93	47	24				-20%	-98%	259
94						-15%	-99%	262
95	48					-10%	-100%	264
96						-5%	-100%	267
97	49	25	13	7		0%	-100%	270
98						5%	-100%	273
99	50					10%	-100%	276
100						15%	-99%	278
101	51	26				20%	-98%	281
102						24%	-97%	284
103	52					29%	-96%	287
104						34%	-94%	290
105	53	27	14			38%	-92%	293
106						43%	-90%	295
107	54					47%	-88%	298
108						51%	-86%	301
109	55	28				56%	-83%	304
110						60%	-80%	307
111	56					63%	-77%	309
112						67%	-74%	312
113	57	29	15	8	4	71%	-71%	315
114						74%	-67%	318
115	58					77%	-63%	321
116						80%	-60%	323
117	59	30				83%	-56%	326
118						86%	-51%	329
119	60					88%	-47%	332
120						90%	-43%	335
121	61	31	16			92%	-38%	338
122						94%	-34%	340
123	62					96%	-29%	343
124						97%	-24%	346
125	63	32				98%	-20%	349
126						99%	-15%	352
127	64					100%	-10%	354
128						100%	-5%	357

8.3.5 nRESET, nENBLE and nSLEEP Operation

The nRESET terminal, when driven active low, resets internal logic, and resets the step table to the home position. It also disables the H-bridge drivers. The STEP input is ignored while nRESET is active.

The nENBL terminal is used to control the output drivers and enable/disable operation of the indexer. When nENBL is low, the output H-bridges are enabled, and rising edges on the STEP terminal are recognized. When nENBL is high, the H-bridges are disabled, the outputs are in a high-impedance state, and the STEP input is ignored.

Driving nSLEEP low will put the device into a low power sleep state. In this state, the H-bridges are disabled, the gate drive charge pump is stopped, the V3P3OUT regulator is disabled, and all internal clocks are stopped. In this state all inputs are ignored until nSLEEP returns inactive high. When returning from sleep mode, some time (approximately 1 ms) needs to pass before applying a STEP input, to allow the internal circuitry to stabilize.

The nRESET and nENABLE terminals have internal pulldown resistors of 100 kΩ. The nSLEEP terminal has an internal pulldown resistor of 1 MΩ.

8.3.6 Protection Circuits

The DRV8824-Q1 is fully protected against undervoltage, overcurrent and overtemperature events.

8.3.6.1 Overcurrent Protection (OCP)

An analog current limit circuit on each FET limits the current through the FET by removing the gate drive. If this analog current limit persists for longer than the OCP time, all FETs in the H-bridge will be disabled and the nFAULT terminal will be driven low. The device will remain disabled until either nRESET terminal is applied, or VM is removed and re-applied.

Overcurrent conditions on both high and low side devices; i.e., a short to ground, supply, or across the motor winding will all result in an overcurrent shutdown. Note that overcurrent protection does not use the current sense circuitry used for PWM current control, and is independent of the I_{SENSE} resistor value or VREF voltage.

8.3.6.2 Thermal Shutdown (TSD)

If the die temperature exceeds safe limits, all FETs in the H-bridge will be disabled and the nFAULT terminal will be driven low. Once the die temperature has fallen to a safe level operation will automatically resume.

8.3.6.3 Undervoltage Lockout (UVLO)

If at any time the voltage on the VM terminals falls below the undervoltage lockout threshold voltage, all circuitry in the device will be disabled and internal logic will be reset. Operation will resume when V_M rises above the UVLO threshold.

8.3.7 Thermal Information

8.3.7.1 Thermal Protection

The DRV8824-Q1 has thermal shutdown (TSD) as described above. If the die temperature exceeds approximately 150°C, the device will be disabled until the temperature drops to a safe level.

Any tendency of the device to enter TSD is an indication of either excessive power dissipation, insufficient heatsinking, or too high an ambient temperature.

8.3.7.2 Power Dissipation

Power dissipation in the DRV8824-Q1 is dominated by the power dissipated in the output FET resistance, or R_{DS(ON)}. Average power dissipation when running a stepper motor can be roughly estimated by [Equation 2](#).

$$P_{TOT} = 4 \cdot R_{DS(ON)} \cdot (I_{OUT(RMS)})^2 \quad (2)$$

where P_{TOT} is the total power dissipation, R_{DS(ON)} is the resistance of each FET, and I_{OUT(RMS)} is the RMS output current being applied to each winding. I_{OUT(RMS)} is equal to the approximately 0.7x the full-scale output current setting. The factor of 4 comes from the fact that there are two motor windings, and at any instant two FETs are conducting winding current for each winding (one high-side and one low-side).

The maximum amount of power that can be dissipated in the device is dependent on ambient temperature and heatsinking.

Note that R_{DS(ON)} increases with temperature, so as the device heats, the power dissipation increases. This must be taken into consideration when sizing the heatsink.

8.3.7.3 Heatsinking

The PowerPAD™ package uses an exposed pad to remove heat from the device. For proper operation, this pad must be thermally connected to copper on the PCB to dissipate heat. On a multi-layer PCB with a ground plane, this can be accomplished by adding a number of vias to connect the thermal pad to the ground plane. On PCBs without internal planes, copper area can be added on either side of the PCB to dissipate heat. If the copper area is on the opposite side of the PCB from the device, thermal vias are used to transfer the heat between top and bottom layers.

For details about how to design the PCB, refer to TI application report [SLMA002](#), "PowerPAD™ Thermally Enhanced Package" and TI application brief [SLMA004](#), "PowerPAD™ Made Easy", available at www.ti.com.

In general, the more copper area that can be provided, the more power can be dissipated. It can be seen that the heatsink effectiveness increases rapidly to about 20 cm², then levels off somewhat for larger areas.

8.4 Device Functional Modes

8.4.1 Decay Mode

During PWM current chopping, the H-bridge is enabled to drive current through the motor winding until the PWM current chopping threshold is reached. This is shown in [Figure 7](#) as case 1. The current flow direction shown indicates positive current flow.

Once the chopping current threshold is reached, the H-bridge can operate in two different states, fast decay or slow decay.

In fast decay mode, once the PWM chopping current level has been reached, the H-bridge reverses state to allow winding current to flow in a reverse direction. As the winding current approaches zero, the bridge is disabled to prevent any reverse current flow. Fast decay mode is shown in [Figure 7](#) as case 2.

In slow decay mode, winding current is re-circulated by enabling both of the low-side FETs in the bridge. This is shown in [Figure 7](#) as case 3.

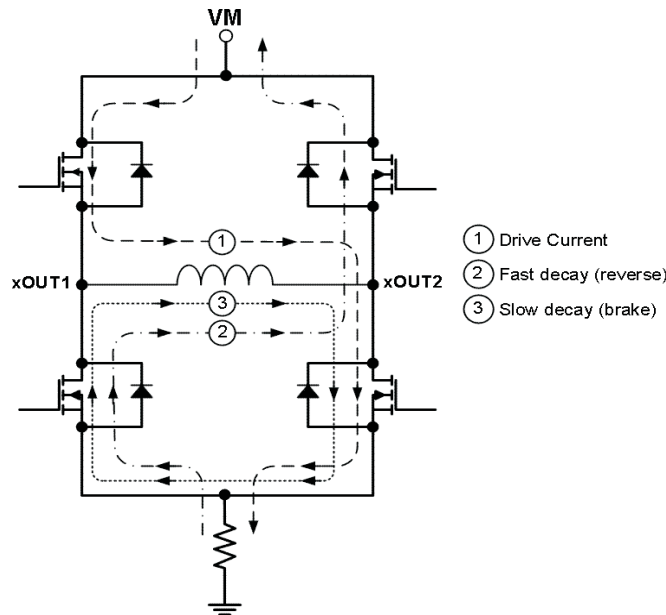

Figure 7. Decay Mode

The DRV8824-Q1 supports fast decay, slow decay and a mixed decay mode. Slow, fast, or mixed decay mode is selected by the state of the DECAY terminal - logic low selects slow decay, open selects mixed decay operation, and logic high sets fast decay mode. The DECAY terminal has both an internal pullup resistor of approximately 130 kΩ and an internal pulldown resistor of approximately 80 kΩ. This sets the mixed decay mode if the terminal is left open or undriven.

Device Functional Modes (continued)

Mixed decay mode begins as fast decay, but at a fixed period of time (75% of the PWM cycle) switches to slow decay mode for the remainder of the fixed PWM period. This occurs only if the current through the winding is decreasing (per the indexer step table); if the current is increasing, then slow decay is used.

9 Application and Implementation

9.1 Application Information

The DRV8824-Q1 is used in bipolar stepper control. The following design procedure can be used to configure the DRV8824-Q1.

9.2 Typical Application

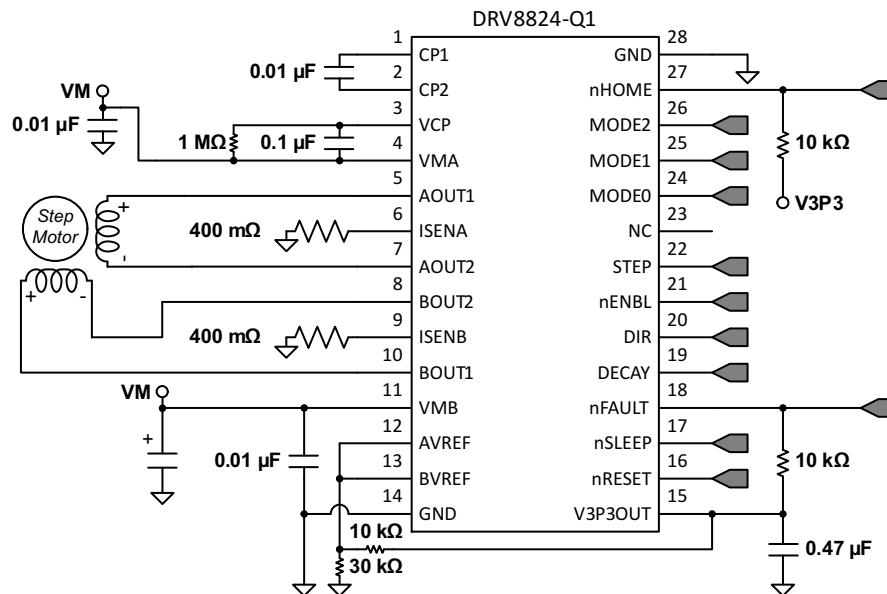

Figure 8. Typical Application Schematic

9.2.1 Design Requirements

Table 3 gives design input parameters for system design.

Table 3. Design Parameters

DESIGN PARAMETER	REFERENCE	EXAMPLE VALUE
Supply voltage	VM	24 V
Motor winding resistance	R_L	1.0 Ω /phase
Motor winding inductance	L_L	3.5 mH/phase
Motor full step angle	θ_{step}	1.8°/step
Target microstepping level	n_m	8 microsteps per step
Target motor speed	v	120 rpm
Target full-scale current	I_{FS}	1.25 A

9.2.2 Detailed Design Procedure

9.2.2.1 Stepper Motor Speed

The first step in configuring the DRV8824-Q1 requires the desired motor speed and microstepping level. If the target application requires a constant speed, then a square wave with frequency f_{step} must be applied to the STEP pin.

If the target motor speed is too high, the motor will not spin. Make sure that the motor can support the target speed.

For a desired motor speed (v), microstepping level (n_m), and motor full step angle (θ_{step}),

$$f_{step}(step/sec) = \frac{v(rpm) \cdot n_m(steps) \cdot 6}{\theta_{step}(^\circ/step)} \quad (3)$$

θ_{step} can be found in the stepper motor datasheet or written on the motor itself.

For the DRV8824-Q1, the microstepping level is set by the USM pins and can be any of the settings in . Higher microstepping will mean a smoother motor motion and less audible noise, but will increase switching losses and require a higher f_{step} to achieve the same motor speed.

9.2.2.2 Current Regulation

In a stepper motor, the full-scale current (I_{FS}) is the maximum current driven through either winding. This quantity will depend on the VREF analog voltage and the sense resistor value (R_{SENSE}). During stepping, I_{FS} defines the current chopping threshold (I_{TRIP}) for the maximum current step.

$$I_{FS}(A) = \frac{VREF(V)}{A_v \cdot R_{SENSE}(\Omega)} = \frac{VREF(V)}{5 \cdot R_{SENSE}(\Omega)} \quad (4)$$

I_{FS} is set by a comparator which compares the voltage across R_{SENSE} to a reference voltage. There is a current sense amplifier built in with programmable gain through ISGAIN. Note that I_{FS} must also follow the equation below in order to avoid saturating the motor. VM is the motor supply voltage and R_L is the motor winding resistance.

$$I_{FS}(A) < \frac{VM(V)}{R_L(\Omega) + 2 \cdot R_{DS(ON)}(\Omega) + RSENSE(\Omega)} \quad (5)$$

9.2.2.3 Decay Modes

The DRV8824-Q1 supports three different decay modes: slow decay, fast decay, and mixed decay. The current through the motor windings is regulated using a fixed-frequency PWM scheme. This means that after any drive phase, when a motor winding current has hit the current chopping threshold (I_{TRIP}), the DRV8824-Q1 will place the winding in one of the three decay modes until the PWM cycle has expired. Afterwards, a new drive phase starts.

The blanking time t_{BLANK} defines the minimum drive time for the current chopping. I_{TRIP} is ignored during t_{BLANK} , so the winding current may overshoot the trip level.

9.2.3 Application Curves

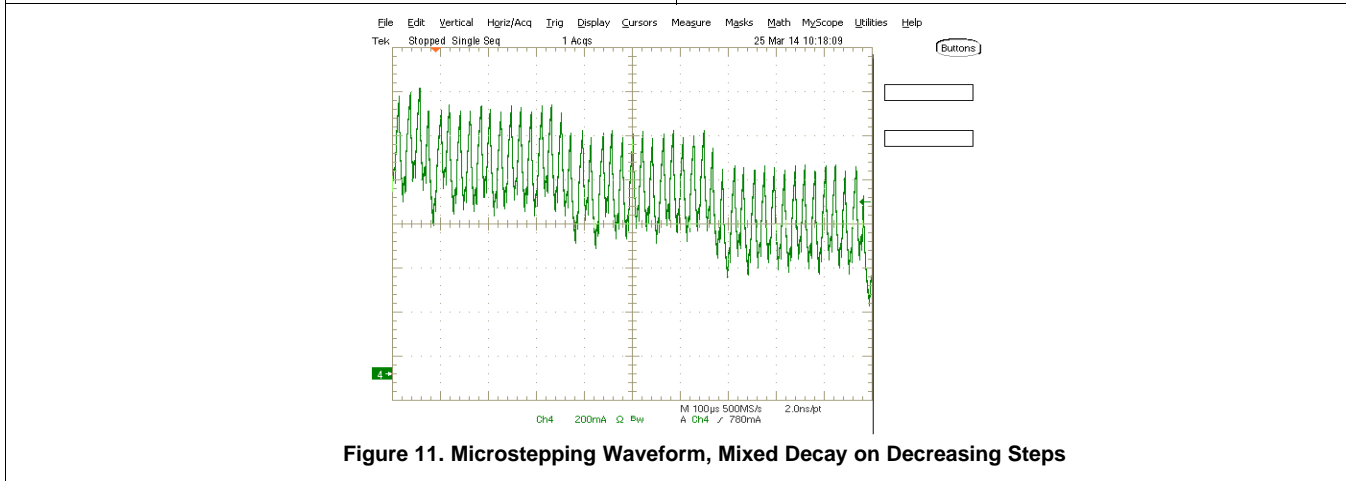
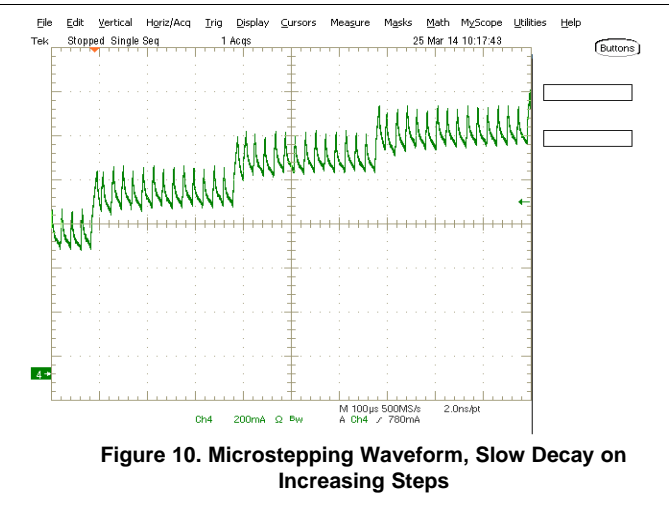
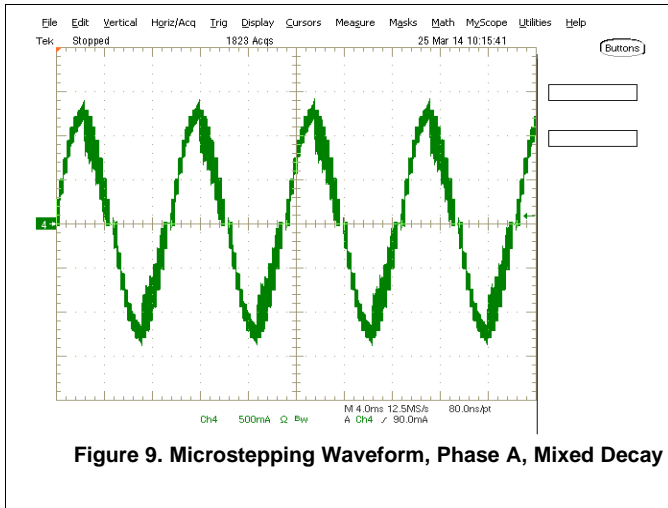

10 Power Supply Recommendations

The DRV8824-Q1 is designed to operate from an input voltage supply (VM) range between 8.2 V and 45 V. Two 0.01- μ F ceramic capacitorS rated for VMA and VMB must be placed as close to the DRV8824-Q1 as possible. In addition, a bulk capacitor must be included. If VMA and VMB are connected to the same board net, a single bulk capacitor is sufficient.

11 Layout

11.1 Layout Guidelines

The VMA and VMB terminals should be bypassed to GND using low-ESR ceramic bypass capacitors with a recommended value of $0.01\ \mu\text{F}$ rated for VM. This capacitor should be placed as close to the VMA and VMB pins as possible with a thick trace or ground plane connection to the device GND pin.

The VMA and VMB pins must be bypassed to ground using a bulk capacitor. This component may be an electrolytic. If VMA and VMB are connected to the same board net, a single bulk capacitor is sufficient.

A low-ESR ceramic capacitor must be placed in between the CPL and CPH pins. A value of $0.01\ \mu\text{F}$ rated for VMA and VMB is recommended. Place this component as close to the pins as possible.

A low-ESR ceramic capacitor must be placed in between the VMA and VCP pins. A value of $0.1\ \mu\text{F}$ rated for 16 V is recommended. Place this component as close to the pins as possible. In addition place a $1\text{-M}\Omega$ resistor between VCP and VMA.

Bypass V3P3 to ground with a ceramic capacitor rated 6.3 V. Place this bypassing capacitor as close to the pin as possible.

11.2 Layout Example

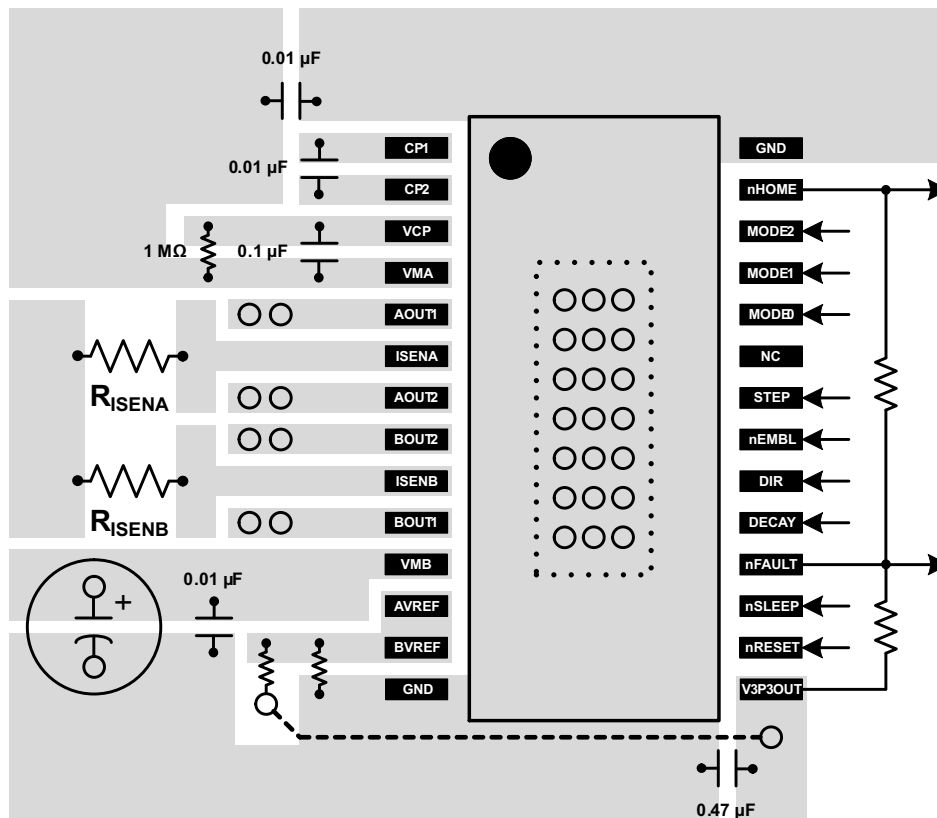

Figure 12. DRV8824-Q1 Board Layout

12 Device and Documentation Support

12.1 Trademarks

PowerPAD is a trademark of Texas Instruments.
All other trademarks are the property of their respective owners.

12.2 Electrostatic Discharge Caution



These devices have limited built-in ESD protection. The leads should be shorted together or the device placed in conductive foam during storage or handling to prevent electrostatic damage to the MOS gates.

12.3 Glossary

[SLYZ022](#) — *TI Glossary*.

This glossary lists and explains terms, acronyms and definitions.

13 Mechanical, Packaging, and Orderable Information

The following pages include mechanical, packaging, and orderable information. This information is the most current data available for the designated devices. This data is subject to change without notice and revision of this document. For browser-based versions of this data sheet, refer to the left-hand navigation.

PACKAGING INFORMATION

Orderable Device	Status (1)	Package Type	Package Drawing	Pins	Package Qty	Eco Plan (2)	Lead/Ball Finish (6)	MSL Peak Temp (3)	Op Temp (°C)	Device Marking (4/5)	Samples
DRV8824QPWRQ1	ACTIVE	HTSSOP	PWP	28	2000	Green (RoHS & no Sb/Br)	CU NIPDAU	Level-3-260C-168 HR	-40 to 125	DRV8824Q1	Samples

(1) The marketing status values are defined as follows:

ACTIVE: Product device recommended for new designs.

LIFEBUY: TI has announced that the device will be discontinued, and a lifetime-buy period is in effect.

NRND: Not recommended for new designs. Device is in production to support existing customers, but TI does not recommend using this part in a new design.

PREVIEW: Device has been announced but is not in production. Samples may or may not be available.

OBSELETE: TI has discontinued the production of the device.

(2) Eco Plan - The planned eco-friendly classification: Pb-Free (RoHS), Pb-Free (RoHS Exempt), or Green (RoHS & no Sb/Br) - please check <http://www.ti.com/productcontent> for the latest availability information and additional product content details.

TBD: The Pb-Free/Green conversion plan has not been defined.

Pb-Free (RoHS): TI's terms "Lead-Free" or "Pb-Free" mean semiconductor products that are compatible with the current RoHS requirements for all 6 substances, including the requirement that lead not exceed 0.1% by weight in homogeneous materials. Where designed to be soldered at high temperatures, TI Pb-Free products are suitable for use in specified lead-free processes.

Pb-Free (RoHS Exempt): This component has a RoHS exemption for either 1) lead-based flip-chip solder bumps used between the die and package, or 2) lead-based die adhesive used between the die and leadframe. The component is otherwise considered Pb-Free (RoHS compatible) as defined above.

Green (RoHS & no Sb/Br): TI defines "Green" to mean Pb-Free (RoHS compatible), and free of Bromine (Br) and Antimony (Sb) based flame retardants (Br or Sb do not exceed 0.1% by weight in homogeneous material)

(3) MSL, Peak Temp. - The Moisture Sensitivity Level rating according to the JEDEC industry standard classifications, and peak solder temperature.

(4) There may be additional marking, which relates to the logo, the lot trace code information, or the environmental category on the device.

(5) Multiple Device Markings will be inside parentheses. Only one Device Marking contained in parentheses and separated by a "~" will appear on a device. If a line is indented then it is a continuation of the previous line and the two combined represent the entire Device Marking for that device.

(6) Lead/Ball Finish - Orderable Devices may have multiple material finish options. Finish options are separated by a vertical ruled line. Lead/Ball Finish values may wrap to two lines if the finish value exceeds the maximum column width.

Important Information and Disclaimer: The information provided on this page represents TI's knowledge and belief as of the date that it is provided. TI bases its knowledge and belief on information provided by third parties, and makes no representation or warranty as to the accuracy of such information. Efforts are underway to better integrate information from third parties. TI has taken and continues to take reasonable steps to provide representative and accurate information but may not have conducted destructive testing or chemical analysis on incoming materials and chemicals. TI and TI suppliers consider certain information to be proprietary, and thus CAS numbers and other limited information may not be available for release.

In no event shall TI's liability arising out of such information exceed the total purchase price of the TI part(s) at issue in this document sold by TI to Customer on an annual basis.

OTHER QUALIFIED VERSIONS OF DRV8824-Q1 :

- Catalog: [DRV8824](#)

NOTE: Qualified Version Definitions:

- Catalog - TI's standard catalog product

TAPE AND REEL INFORMATION



QUADRANT ASSIGNMENTS FOR PIN 1 ORIENTATION IN TAPE



*All dimensions are nominal

Device	Package Type	Package Drawing	Pins	SPQ	Reel Diameter (mm)	Reel Width W1 (mm)	A0 (mm)	B0 (mm)	K0 (mm)	P1 (mm)	W (mm)	Pin1 Quadrant
DRV8824QPWRQ1	HTSSOP	PWP	28	2000	330.0	16.4	6.9	10.2	1.8	12.0	16.0	Q1

TAPE AND REEL BOX DIMENSIONS

*All dimensions are nominal

Device	Package Type	Package Drawing	Pins	SPQ	Length (mm)	Width (mm)	Height (mm)
DRV8824QPWPRQ1	HTSSOP	PWP	28	2000	350.0	350.0	43.0

GENERIC PACKAGE VIEW

PWP 28

PowerPAD™ TSSOP - 1.2 mm max height

4.4 x 9.7, 0.65 mm pitch

SMALL OUTLINE PACKAGE

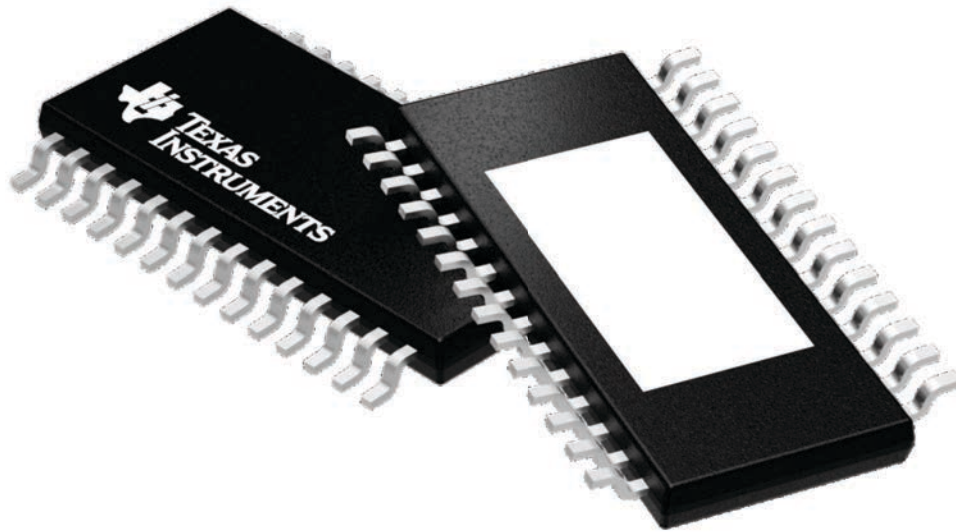

Images above are just a representation of the package family, actual package may vary.
Refer to the product data sheet for package details.

4224765/A

MECHANICAL DATA

PWP (R-PDSO-G28)

PowerPAD™ PLASTIC SMALL OUTLINE

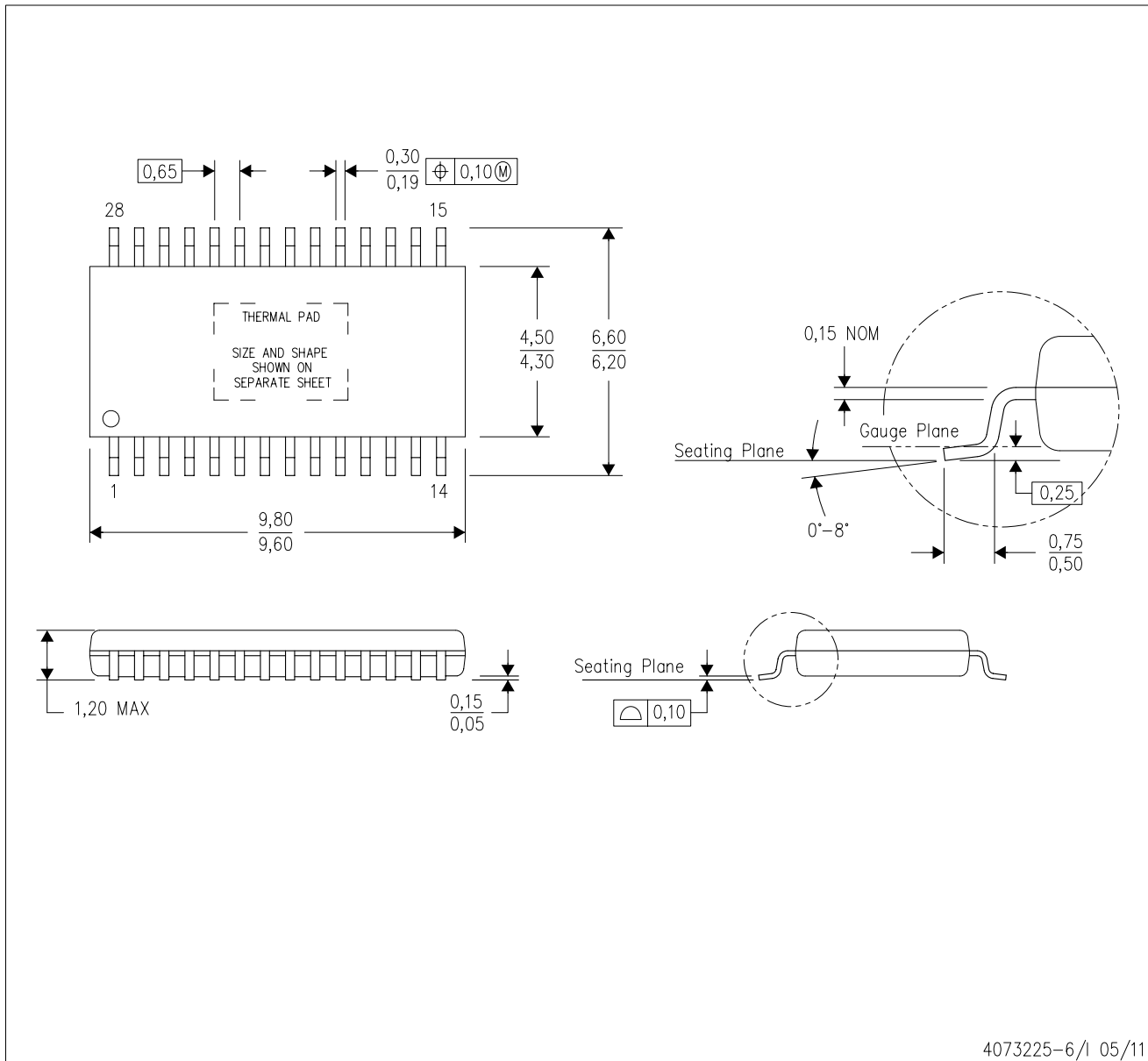

- NOTES:
- All linear dimensions are in millimeters.
 - This drawing is subject to change without notice.
 - Body dimensions do not include mold flash or protrusions. Mold flash and protrusion shall not exceed 0.15 per side.
 - This package is designed to be soldered to a thermal pad on the board. Refer to Technical Brief, PowerPad Thermally Enhanced Package, Texas Instruments Literature No. SLMA002 for information regarding recommended board layout. This document is available at www.ti.com <<http://www.ti.com>>.
 - See the additional figure in the Product Data Sheet for details regarding the exposed thermal pad features and dimensions.
 - Falls within JEDEC MO-153

PowerPAD is a trademark of Texas Instruments.

THERMAL PAD MECHANICAL DATA

PWP (R-PDSO-G28) PowerPAD™ SMALL PLASTIC OUTLINE

THERMAL INFORMATION

This PowerPAD™ package incorporates an exposed thermal pad that is designed to be attached to a printed circuit board (PCB). The thermal pad must be soldered directly to the PCB. After soldering, the PCB can be used as a heatsink. In addition, through the use of thermal vias, the thermal pad can be attached directly to the appropriate copper plane shown in the electrical schematic for the device, or alternatively, can be attached to a special heatsink structure designed into the PCB. This design optimizes the heat transfer from the integrated circuit (IC).

For additional information on the PowerPAD package and how to take advantage of its heat dissipating abilities, refer to Technical Brief, PowerPAD Thermally Enhanced Package, Texas Instruments Literature No. SLMA002 and Application Brief, PowerPAD Made Easy, Texas Instruments Literature No. SLMA004. Both documents are available at www.ti.com.

The exposed thermal pad dimensions for this package are shown in the following illustration.

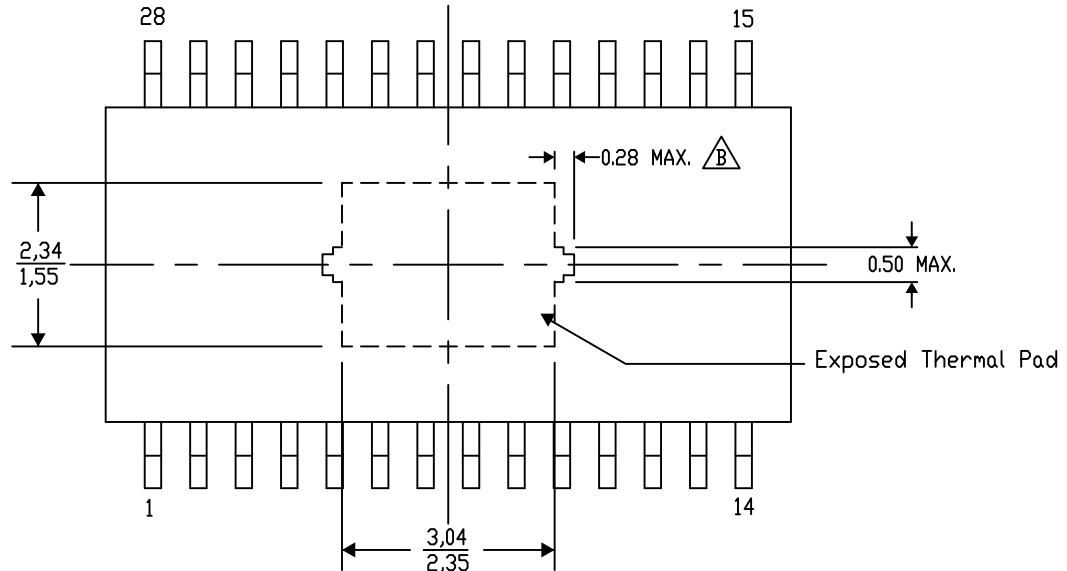

Exposed Thermal Pad Dimensions

4206332-39/AO 01/16

NOTE: A. All linear dimensions are in millimeters
⚠ Exposed tie strap features may not be present.

PowerPAD is a trademark of Texas Instruments

PWP (R-PDSO-G28)

PowerPAD™ PLASTIC SMALL OUTLINE

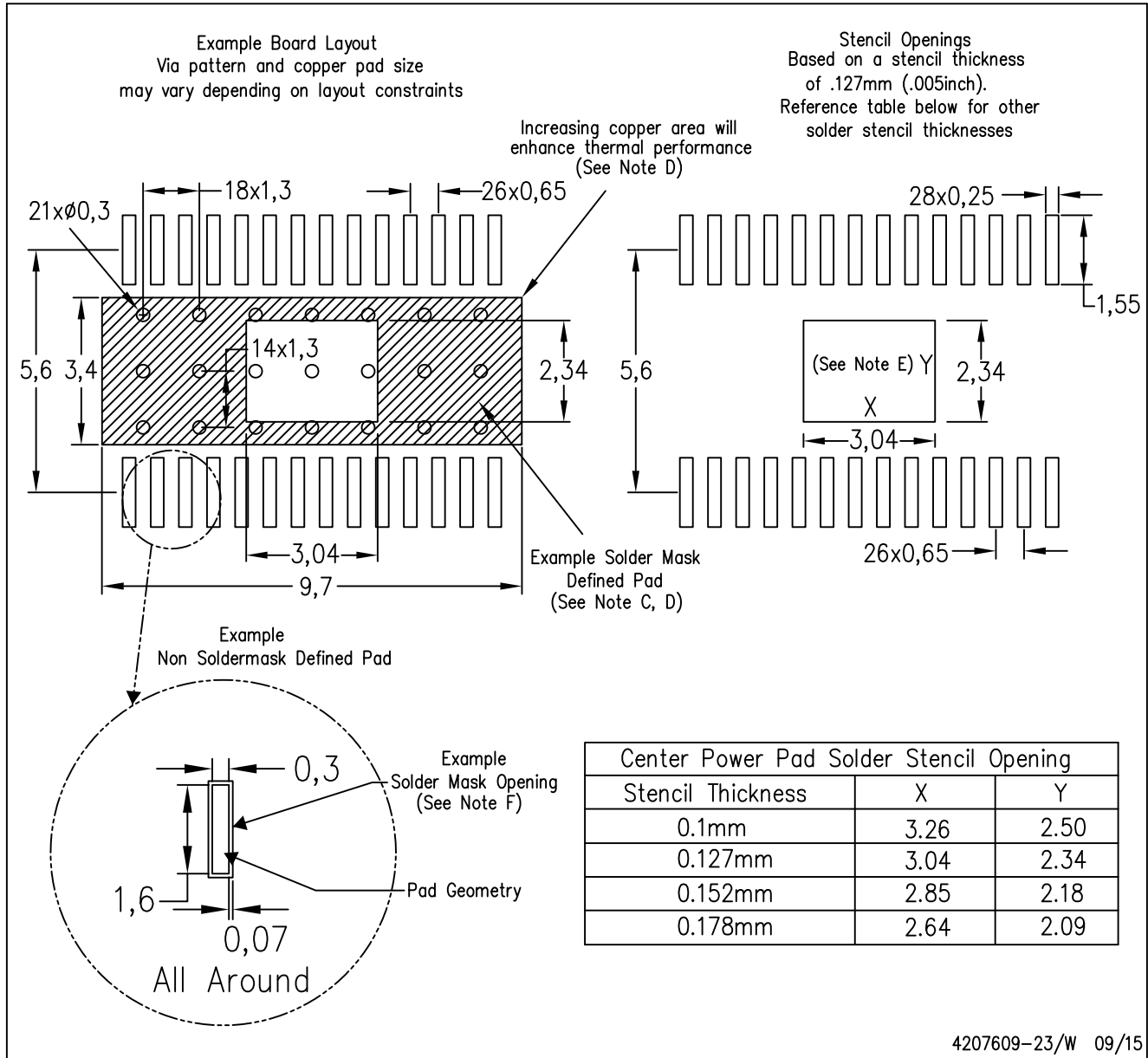

4207609-23/W 09/15

- NOTES:
- A. All linear dimensions are in millimeters.
 - B. This drawing is subject to change without notice.
 - C. Customers should place a note on the circuit board fabrication drawing not to alter the center solder mask defined pad.
 - D. This package is designed to be soldered to a thermal pad on the board. Refer to Technical Brief, PowerPad Thermally Enhanced Package, Texas Instruments Literature No. SLMA002, SLMA004, and also the Product Data Sheets for specific thermal information, via requirements, and recommended board layout. These documents are available at www.ti.com <<http://www.ti.com>>. Publication IPC-7351 is recommended for alternate designs.
 - E. Laser cutting apertures with trapezoidal walls and also rounding corners will offer better paste release. Customers should contact their board assembly site for stencil design recommendations. Example stencil design based on a 50% volumetric metal load solder paste. Refer to IPC-7525 for other stencil recommendations.
 - F. Customers should contact their board fabrication site for solder mask tolerances between and around signal pads.

IMPORTANT NOTICE AND DISCLAIMER

TI PROVIDES TECHNICAL AND RELIABILITY DATA (INCLUDING DATASHEETS), DESIGN RESOURCES (INCLUDING REFERENCE DESIGNS), APPLICATION OR OTHER DESIGN ADVICE, WEB TOOLS, SAFETY INFORMATION, AND OTHER RESOURCES "AS IS" AND WITH ALL FAULTS, AND DISCLAIMS ALL WARRANTIES, EXPRESS AND IMPLIED, INCLUDING WITHOUT LIMITATION ANY IMPLIED WARRANTIES OF MERCHANTABILITY, FITNESS FOR A PARTICULAR PURPOSE OR NON-INFRINGEMENT OF THIRD PARTY INTELLECTUAL PROPERTY RIGHTS.

These resources are intended for skilled developers designing with TI products. You are solely responsible for (1) selecting the appropriate TI products for your application, (2) designing, validating and testing your application, and (3) ensuring your application meets applicable standards, and any other safety, security, or other requirements. These resources are subject to change without notice. TI grants you permission to use these resources only for development of an application that uses the TI products described in the resource. Other reproduction and display of these resources is prohibited. No license is granted to any other TI intellectual property right or to any third party intellectual property right. TI disclaims responsibility for, and you will fully indemnify TI and its representatives against, any claims, damages, costs, losses, and liabilities arising out of your use of these resources.

TI's products are provided subject to TI's Terms of Sale (www.ti.com/legal/termsofsale.html) or other applicable terms available either on ti.com or provided in conjunction with such TI products. TI's provision of these resources does not expand or otherwise alter TI's applicable warranties or warranty disclaimers for TI products.

Mailing Address: Texas Instruments, Post Office Box 655303, Dallas, Texas 75265
Copyright © 2019, Texas Instruments Incorporated

Looking for pricing, stock, or lifecycle information?

Click below to explore more details on WIN SOURCE:

 [View DRV8824QPWPRQ1 on WIN SOURCE](#)

 [Texas Instruments](#) Information

Optimize Your Supply Chain with WIN SOURCE Solutions

-  Global Sourcing Solution
-  Obsolete Management
-  Cost Control Management
-  Shortage Management
-  Alternative Solution
-  Excess Inventory Management