

FOD060L, FOD260L, FOD063L LVTTTL/LVCMOS 3.3V High Speed-10 MBit/s Logic Gate Optocouplers

Single Channel: FOD060L, FOD260L
Dual Channel: FOD063L

Features

- Compact SO8 package (except FOD260L – 8-pin DIP)
- Very high speed – 10 MBit/s
- Superior CMR — 50 kV/μs at 2,000V peak
- Fan-out of 8 over -40°C to +85°C
- Logic gate output
- Strobable output (single channel devices)
- Wired OR-open collector
- U.L. recognized (File # E90700) (pending)
- UDE approval pending

Applications

- Ground loop elimination
- LSTTL to TTL, LSTTL or 5-volt CMOS
- Line receiver, data transmission

- Data multiplexing
- Switching power supplies
- Pulse transformer replacement
- Computer-peripheral interface

Description

These optocouplers consist of an AlGaAs LED, optically coupled to a very high speed integrated photo-detector logic gate. Single channel devices include a strobable output. This output features an open collector, thereby permitting wired OR outputs. The output consists of bipolar transistors in a Bi-CMOS process for reduced power consumption. The coupled parameters are guaranteed over the temperature range of -40°C to +85°C. A maximum input signal of 5 mA (3 mA for the FODX6XL versions) will provide a minimum output sink current of 13 mA (fan out of 8). An internal noise shield provides superior common mode rejection of typically 50 kV/μs at 2,000V common mode.

Package

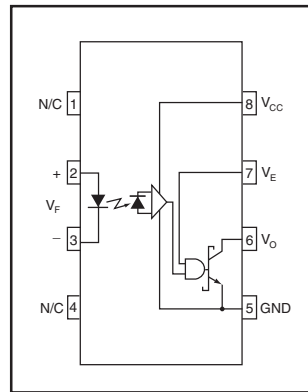
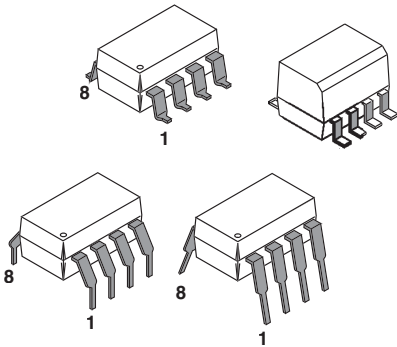

Single-channel circuit drawing
(FOD060L, FOD260L)

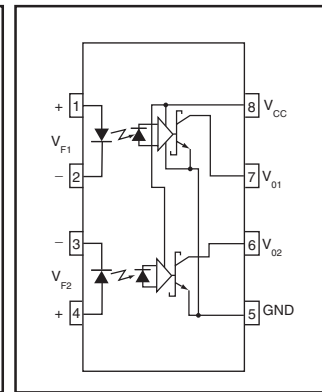

Dual-channel circuit drawing
(FOD063L)

Truth Table (Positive Logic)

Input	Enable	Output
H	H	L
L	H	H
H	L	H
L	L	H
H*	NC*	L*
L*	NC*	H*

*Dual channel devices or single channel devices with pin 7 not connected.
A 0.1 μF bypass capacitor must be connected between pins 8 and 5. (See note 1)

Absolute Maximum Ratings (No derating required up to 85°C)

Parameter		Symbol	Value	Units
Storage Temperature		T_{STG}	-40 to +125	°C
Operating Temperature		T_{OPR}	-40 to +85	°C
EMITTER				
DC/Average Forward Input Current (each channel)		I_F	50	mA
Enable Input Voltage Not to exceed VCC by more than 500 mV	Single Channel	V_E	$V_{CC} + 0.5V$	V
Reverse Input Voltage (each channel)		V_R	5.0	V
Power Dissipation	Single Channel	P_I	45	mW
	Dual Channel			
DETECTOR				
Supply Voltage		V_{CC} (1 minute max)	7.0	V
Output Current (each channel)		I_O	50	mA
Output Voltage (each channel)		V_O	7.0	V
Collector Output Power Dissipation	Single Channel	P_O	85	mW
	Dual Channel			

Recommended Operating Conditions

Parameter	Symbol	Min	Max	Units
Input Current, Low Level	I_{FL}	0	250	μA
Input Current, High Level	I_{FH}	*6.3	15	mA
Supply Voltage, Output	V_{CC}	2.7	3.3	V
Enable Voltage, Low Level (Single Channel)	V_{EL}	0	0.8	V
Enable Voltage, High Level (Single Channel)	V_{EH}	2.0	V_{CC}	V
Operating Temperature	T_A	-40	+85	°C
Fan Out (TTL load)	N		8	
Output Pull-up Resistor	R_L	330	4K	Ω

*6.3 mA is a guard banded value which allows for at least 20% CTR degradation. Initial input current threshold value is 5.0 mA or less.

Electrical Characteristics ($T_A = -40^\circ\text{C}$ to $+85^\circ\text{C}$ unless otherwise specified.)

Individual Component Characteristics

Parameter	Test Conditions	Symbol	Min	Typ**	Max	Unit
EMITTER	($I_F = 10\text{ mA}$)	V_F			1.8	V
Input Forward Voltage	$T_A = 25^\circ\text{C}$				1.75	
Input Reverse Breakdown Voltage	($I_R = 10\ \mu\text{A}$)	B_{VR}	5.0			V
Input Capacitance	($V_F = 0, f = 1\text{ MHz}$)	C_{IN}				pF
Input Diode Temperature Coefficient	($I_F = 10\text{ mA}$)	$\Delta V_F/\Delta T_A$				mV/ $^\circ\text{C}$
DETECTOR	($V_E = 0.5\text{ V}$)	Single Channel			7	mA
High Level Supply Current	($I_F = 0\text{ mA}, V_{CC} = 3.3\text{ V}$)	Dual Channel			10	
Low Level Supply Current	($V_E = 0.5\text{ V}$)	Single Channel			10	mA
	($I_F = 10\text{ mA}, V_{CC} = 3.3\text{ V}$)	Dual Channel			15	
Low Level Enable Current	($V_{CC} = 3.3\text{ V}, V_E = 0.5\text{ V}$)	Single Channel			-1.6	mA
High Level Enable Current	($V_{CC} = 3.3\text{ V}, V_E = 2.0\text{ V}$)	Single Channel			-1.6	mA
High Level Enable Voltage	($V_{CC} = 3.3\text{ V}, I_F = 10\text{ mA}$)	Single Channel	V_{EH}	2.0		V
Low Level Enable Voltage	($V_{CC} = 3.3\text{ V}, I_F = 10\text{ mA}$) (Note 2)	Single Channel	V_{EL}		0.8	V

Switching Characteristics ($T_A = -40^\circ\text{C}$ to $+85^\circ\text{C}$, $V_{CC} = 3.3\text{ V}$, $I_F = 7.5\text{ mA}$ unless otherwise specified.)

AC Characteristics	Test Conditions	Device	Symbol	Min	Typ	Max	Unit
Propagation Delay Time to Output High Level	(Note 3) ($R_L = 350\ \Omega, C_L = 15\text{ pF}$) (Fig. 9)	All	T_{PLH}			90	ns
Propagation Delay Time to Output Low Level	(Note 4) ($R_L = 350\ \Omega, C_L = 15\text{ pF}$) (Fig. 9)	All	T_{PHL}			75	ns
Pulse Width Distortion	($R_L = 350\ \Omega, C_L = 15\text{ pF}$) (Fig. 9)	All	$ T_{PHL} - T_{PLH} $			25	ns
Propagation Delay Skew	($R_L = 350\ \Omega, C_L = 15\text{ pF}$) (Note 5)	All	t_{PSK}			40	ns
Output Rise Time (10-90%)	($R_L = 350\ \Omega, C_L = 15\text{ pF}$) (Note 6) (Fig. 9)	All	t_r				ns
Output Fall Time (90-10%)	($R_L = 350\ \Omega, C_L = 15\text{ pF}$) (Note 7) (Fig. 12)	All	t_f				ns
Enable Propagation Delay Time to Output High Level	($V_{EH} = 3\text{ V}, R_L = 350\ \Omega, C_L = 15\text{ pF}$) (Note 8) (Fig. 10)	Single Channel	All	t_{ELH}			ns
Enable Propagation Delay Time to Output Low Level	($V_{EH} = 3\text{ V}, R_L = 350\ \Omega, C_L = 15\text{ pF}$) (Note 9) (Fig. 10)	Single Channel	All	t_{EHL}			ns
Common Mode Transient Immunity (at Output High Level)	($R_L = 350\ \Omega$) ($T_A = 25^\circ\text{C}$) ($I_F = 0\text{ mA}, V_{OH}(\text{Min.}) = 2.0\text{ V}$) (Note 10) (Fig. 11)	$ V_{CM} = 50\text{ V}$	All	$ ICM_H $	25,000	50,000	V/ μs
Common Mode Transient Immunity (at Output Low Level)	($R_L = 350\ \Omega$) ($T_A = 25^\circ\text{C}$) ($I_F = 7.5\text{ mA}, V_{OL}(\text{Max.}) = 0.8\text{ V}$) (Note 11) (Fig. 11)	$ V_{CM} = 50\text{ V}$	All	$ ICM_H $	25,000	50,000	V/ μs

Transfer Characteristics ($T_A = -40^{\circ}\text{C}$ to $+85^{\circ}\text{C}$ Unless otherwise specified.)

DC Characteristics	Test Conditions	Symbol	Min	Typ**	Max	Unit
High Level Output Current	($I_F = 250 \mu\text{A}$, $V_{CC} = 3.3 \text{ V}$, $V_O = 3.3 \text{ V}$)	I_{OH}			50	μA
	(Note 2) $V_E = 2.0 \text{ V}$ Single Channel					
Low Level Output Voltage	($V_{CC} = 3.3 \text{ V}$, $I_F = 5 \text{ mA}$, $I_{OL} = 13 \text{ mA}$)	V_{OL}			0.6	V
	(Note 2) $V_E = 2.0 \text{ V}$ Single Channel					
Input Threshold Current	($V_{CC} = 3.3 \text{ V}$, $V_O = 0.6 \text{ V}$, $I_{OL} = 13 \text{ mA}$)	I_{FT}			5	mA
	(Note 2) $V_E = 2.0 \text{ V}$ Single Channel					

Isolation Characteristics ($T_A = -40^{\circ}\text{C}$ to $+85^{\circ}\text{C}$ Unless otherwise specified.)

Characteristics	Test Conditions	Device	Symbol	Min	Typ**	Max	Unit
Input-Output Insulation Leakage Current	(Relative humidity = 45%) ($T_A = 25^{\circ}\text{C}$, $t = 5 \text{ s}$) ($V_{I-O} = 3000 \text{ VDC}$) (Note 12)		I_{I-O}			1.0*	μA
Withstand Insulation Test Voltage	$I_{IO} \leq 10 \mu\text{A}$, $R_H < 50\%$, $T_A = 25^{\circ}\text{C}$ (Note 12) ($t = 1 \text{ min.}$)	FOD060L FOD063L	V_{ISO}	2500			V_{RMS}
		FOD260L		5000			
Resistance (Input to Output)	($V_{I-O} = 500 \text{ V}$) (Note 12)		R_{I-O}		10^{12}		Ω
Capacitance (Input to Output)	($f = 1 \text{ MHz}$) (Note 12)		C_{I-O}		0.6		pF

** All typical values are at $V_{CC} = 3.3 \text{ V}$, $T_A = 25^{\circ}\text{C}$

Notes

- The V_{CC} supply to each optoisolator must be bypassed by a $0.1 \mu\text{F}$ capacitor or larger. This can be either a ceramic or solid tantalum capacitor with good high frequency characteristic and should be connected as close as possible to the package V_{CC} and GND pins of each device.
- Enable Input – No pull up resistor required as the device has an internal pull up resistor.
- t_{PLH} – Propagation delay is measured from the 3.75 mA level on the HIGH to LOW transition of the input current pulse to the 1.5V level on the LOW to HIGH transition of the output voltage pulse.
- t_{PHL} – Propagation delay is measured from the 3.75 mA level on the LOW to HIGH transition of the input current pulse to the 1.5V level on the HIGH to LOW transition of the output voltage pulse.
- t_{PSK} is the worst case difference between t_{PHL} and t_{PLH} for any devices at the stated test conditions.
- t_r – Rise time is measured from the 90% to the 10% levels on the LOW to HIGH transition of the output pulse.
- t_f – Fall time is measured from the 10% to the 90% levels on the HIGH to LOW transition of the output pulse.
- t_{ELH} – Enable input propagation delay is measured from the 1.5V level on the HIGH to LOW transition of the input voltage pulse to the 1.5V level on the LOW to HIGH transition of the output voltage pulse.
- t_{EHL} – Enable input propagation delay is measured from the 1.5V level on the LOW to HIGH transition of the input voltage pulse to the 1.5V level on the HIGH to LOW transition of the output voltage pulse.
- CM_H – The maximum tolerable rate of rise of the common mode voltage to ensure the output will remain in the high state (i.e., $V_{OUT} > 2.0 \text{ V}$). Measured in volts per microsecond ($\text{V}/\mu\text{s}$).
- CM_L – The maximum tolerable rate of fall of the common mode voltage to ensure the output will remain in the low output state (i.e., $V_{OUT} < 0.8 \text{ V}$). Measured in volts per microsecond ($\text{V}/\mu\text{s}$).
- Device considered a two-terminal device: Pins 1,2,3 and 4 shorted together, and Pins 5,6,7 and 8 shorted together.

Typical Performance Curves

Fig. 1 Input Forward Current vs. Forward Voltage

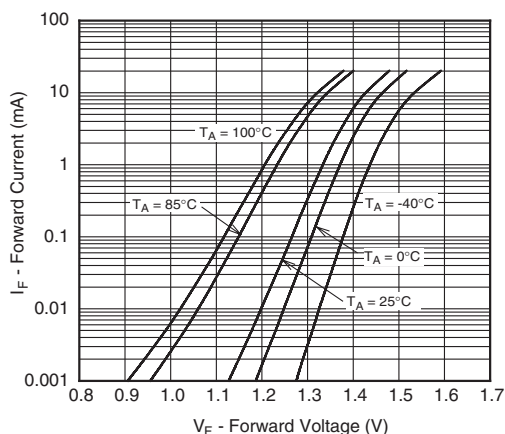

Fig. 2 Input Threshold Current vs. Ambient Temperature

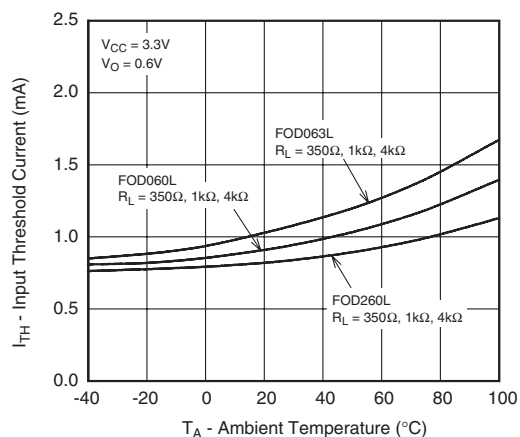

Fig. 3 Low Level Output Voltage vs. Ambient Temperature

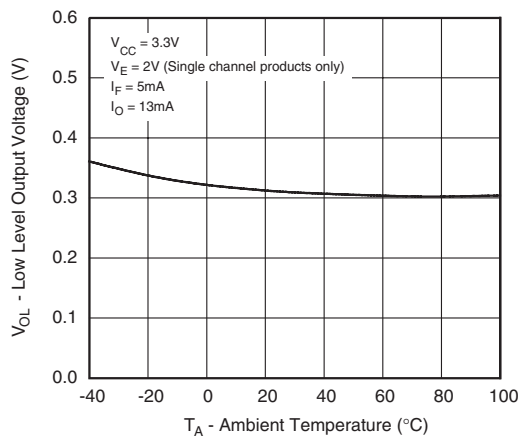

Fig. 4 High Level Output Current vs. Ambient Temperature

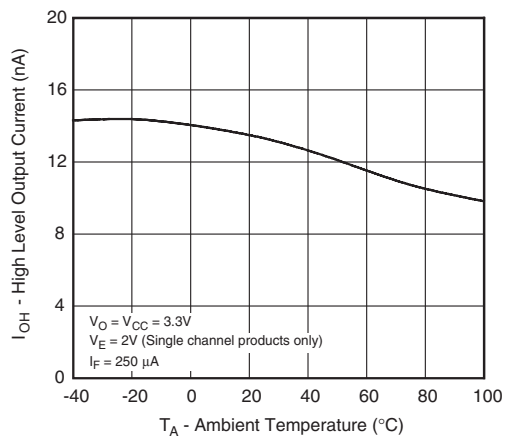

Fig. 5 Low Level Output Current vs. Ambient Temperature

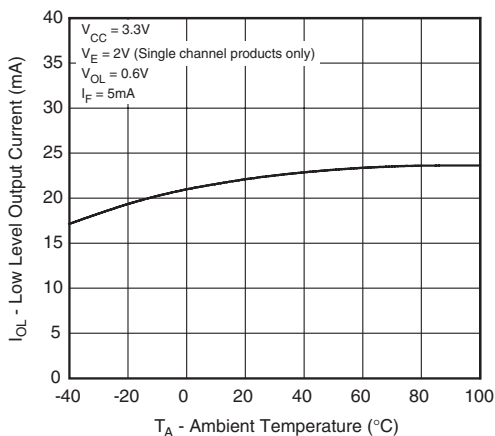
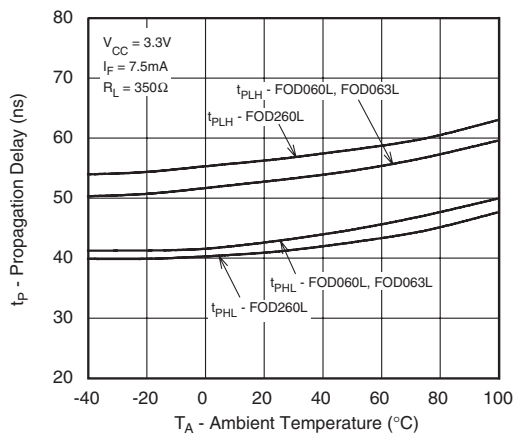

Fig. 6 Propagation Delay vs. Ambient Temperature



Typical Performance Curves

Fig. 7 Rise and Fall Times vs. Ambient Temperature

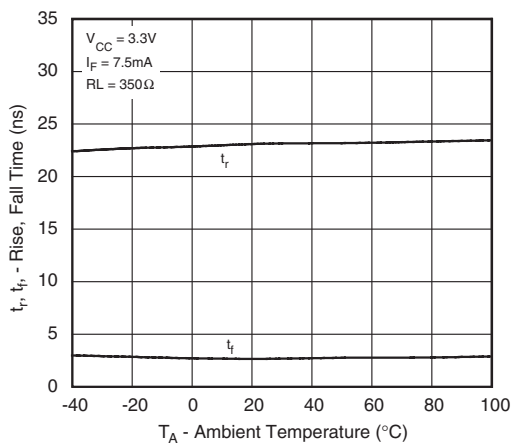
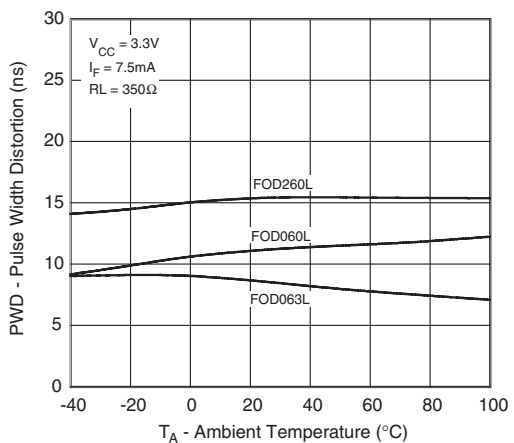

Fig. 8 Pulse Width Distortion vs. Ambient Temperature



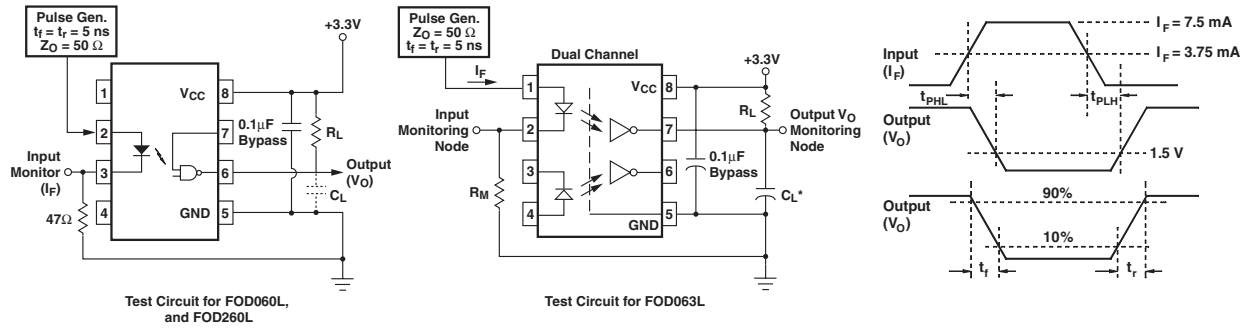

Fig. 9 Test Circuit and Waveforms for t_{PLH} , t_{PHL} , t_r and t_f .

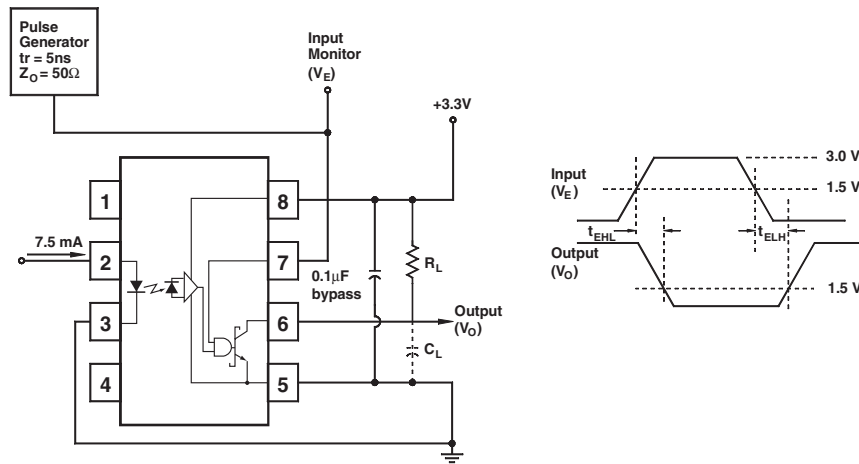

Fig. 10 Test Circuit t_{EHL} and t_{ELH} .

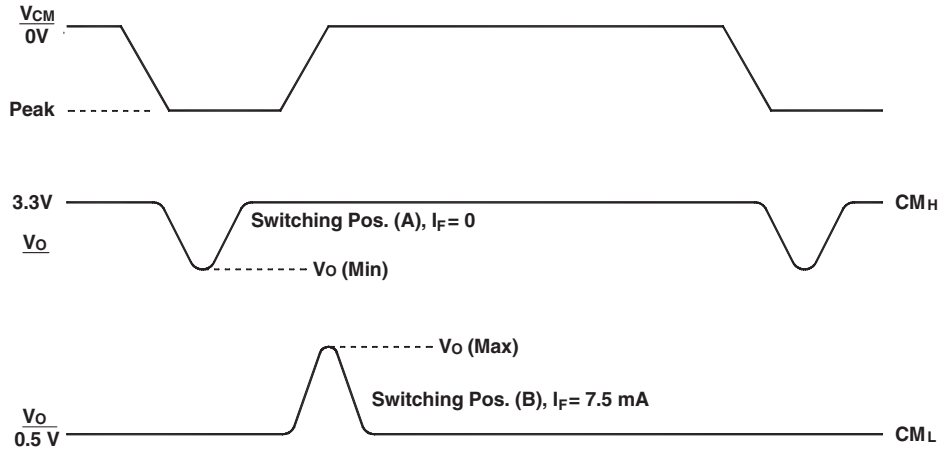
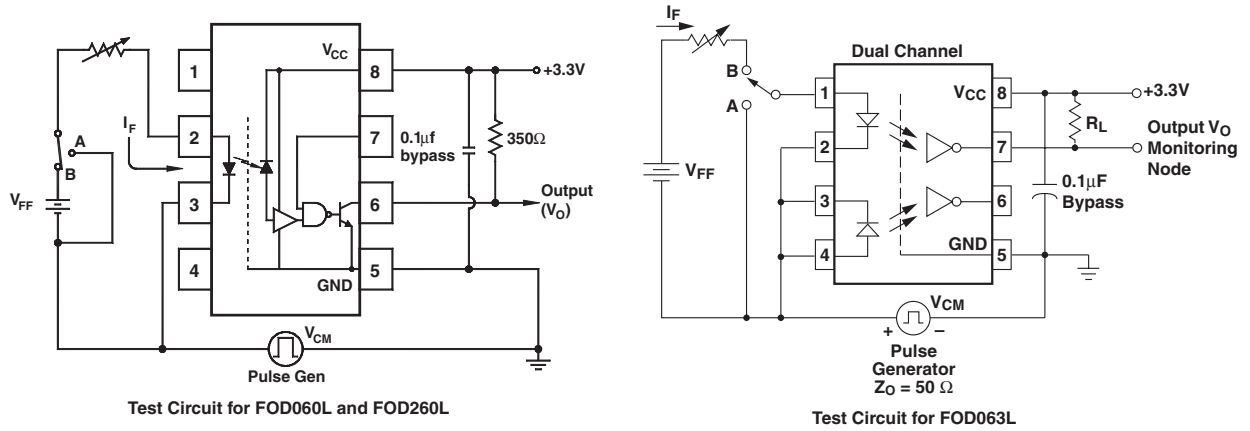
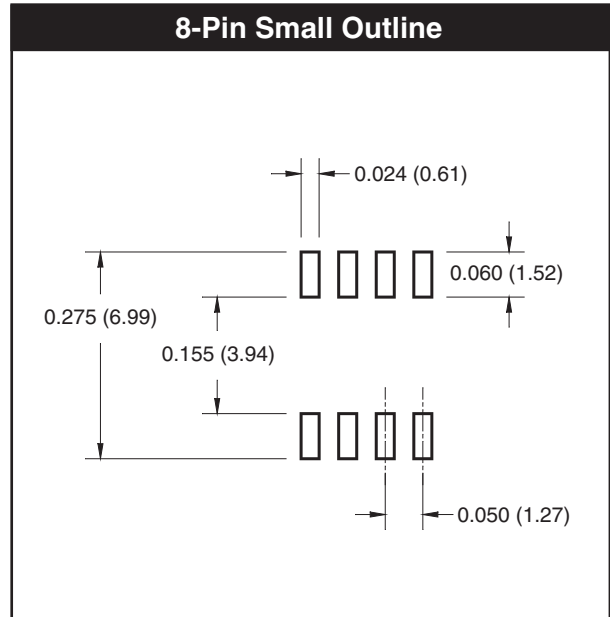
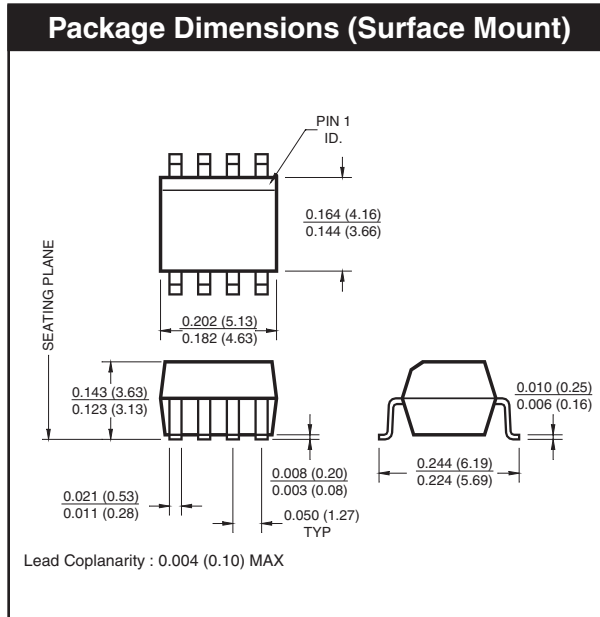

Fig. 11 Test Circuit Common Mode Transient Immunity

8-Pin SOIC



8-Pin DIP

Package Dimensions (Through Hole)

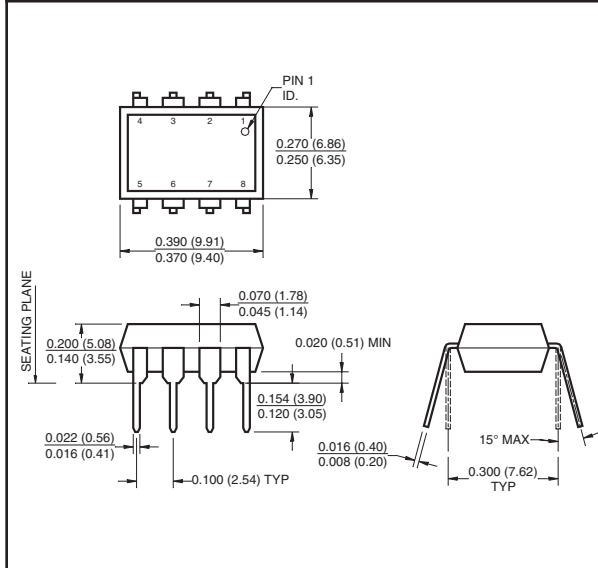

Package Dimensions (Surface Mount)

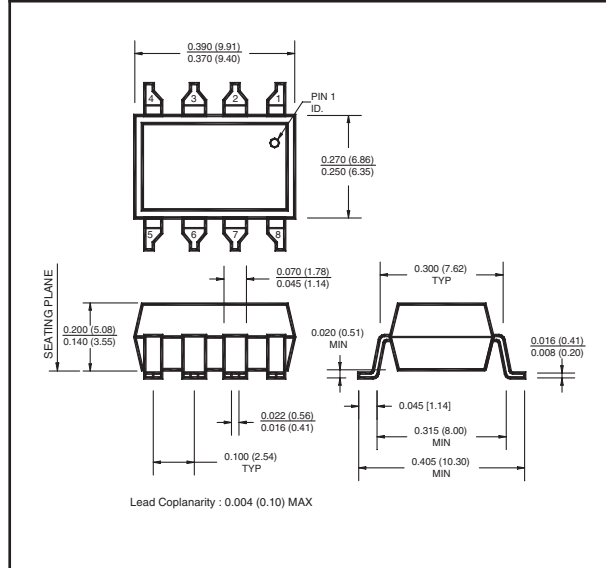

Package Dimensions (0.4" Lead Spacing)

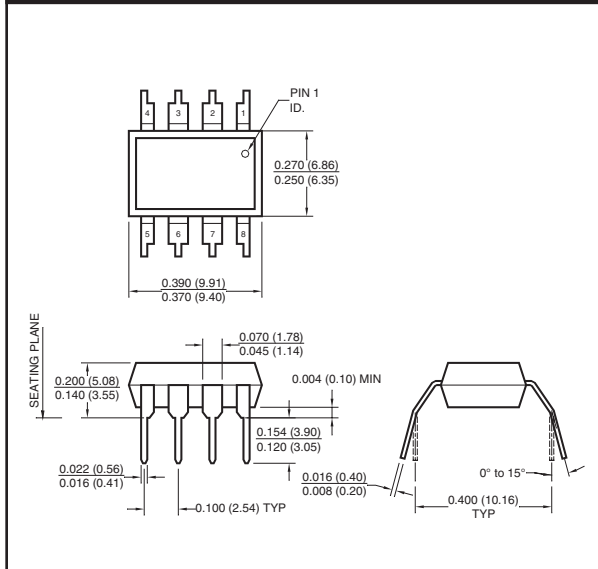

8-Pin DIP

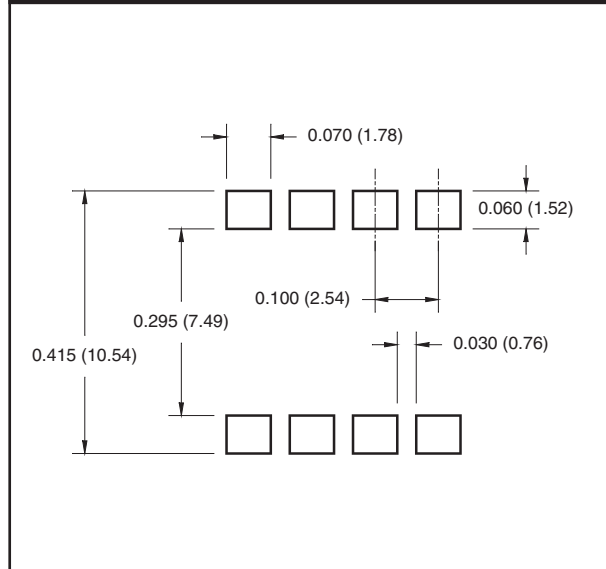

NOTE

All dimensions are in inches (millimeters)

Ordering Information

Option	Order Entry Identifier	Description
No Suffix	FOD260L	Through Hole (DIP package only)
	FOD060L	Surface Mount Lead Form (SOIC-8 package only)
S	FOD260LS	Surface Mount Lead Bend (DIP package only)
SD	FOD260LSD	Surface Mount; Tape and reel (DIP package only)
SV	Pending Approval	Surface Mount; VDE0884 (DIP package only)
SDV	Pending Approval	Surface Mount; Tape and reel, VDE0884 (1000 units per reel) (DIP package only)
T	FOD260LT	0.4" Lead Spacing (DIP package only)
TV	Pending Approval	0.4" Lead Spacing, VDE0884 (DIP package only)
R1	FOD060LR1	Tape and Reel (500 units per reel) (SOIC-8 package only)
R1V	Pending Approval	VDE, Tape and Reel (500 units per reel) (SOIC-8 package only)
R2	FOD060LR2	Tape and Reel (2500 units per reel) (SOIC-8 package only)
R2V	Pending Approval	VDE, Tape and Reel (2500 units per reel) (SOIC-8 package only)
V	Pending Approval	VDE (SOIC-8 package only)

Marking Information

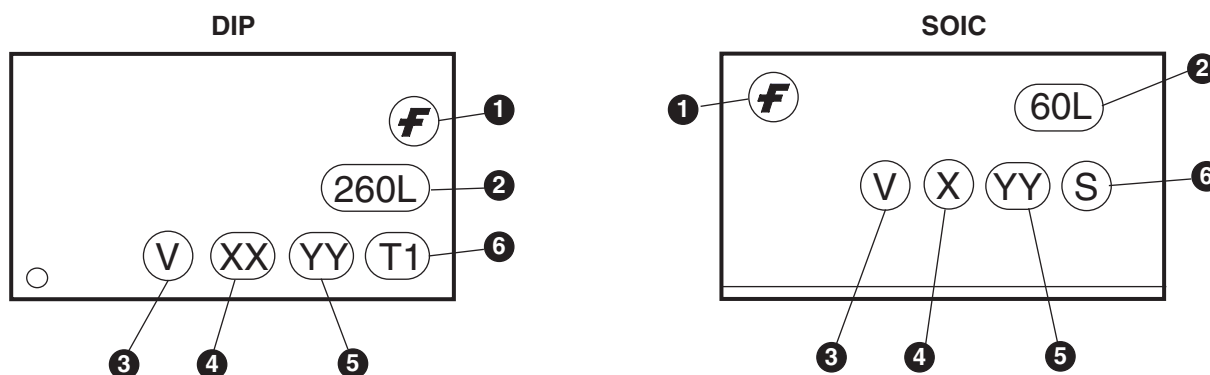

Definitions	
1	Fairchild logo
2	Device number
3	VDE mark (Note: Only appears on parts ordered with VDE option – See order entry table)
4 (DIP)	Two digit year code, e.g., '03'
4 (SOIC)	One digit year code, e.g., '3'
5	Two digit work week ranging from '01' to '53'
6	Assembly package code

8-Pin DIP

Carrier Tape Specifications (FOD260L)

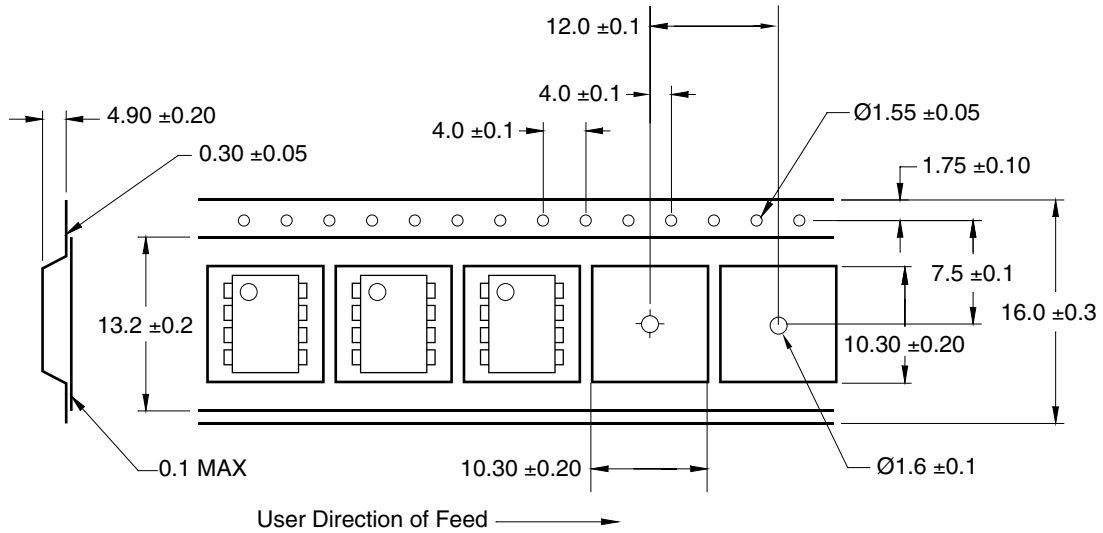

Reflow Profile (FOD260L)

- Peak reflow temperature 260° C (package surface temperature)
- Time of temperature higher than 245° C 40 seconds or less
- Number of reflows Three

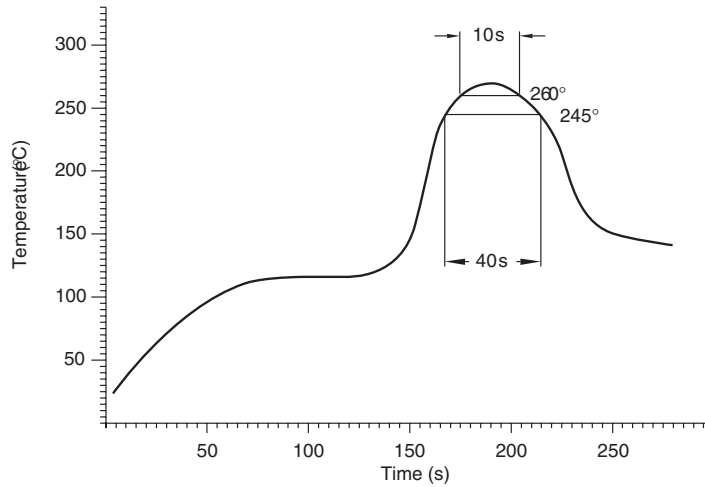

8-Pin SOIC

Carrier Tape Specifications (FOD060L, FOD063L)

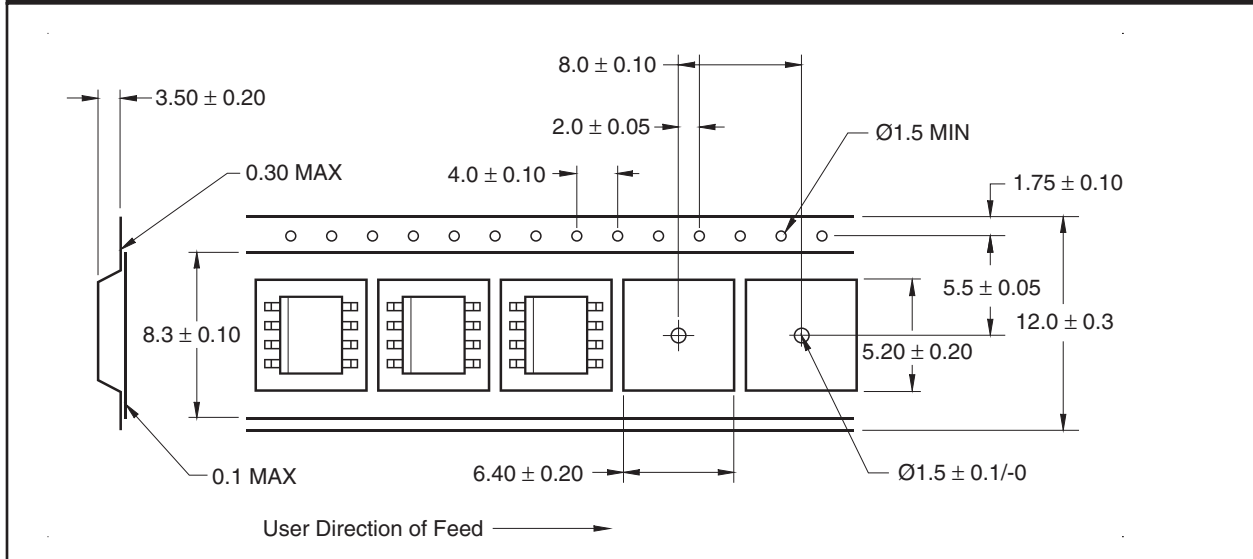

Reflow Profile (FOD060L, FOD063L)

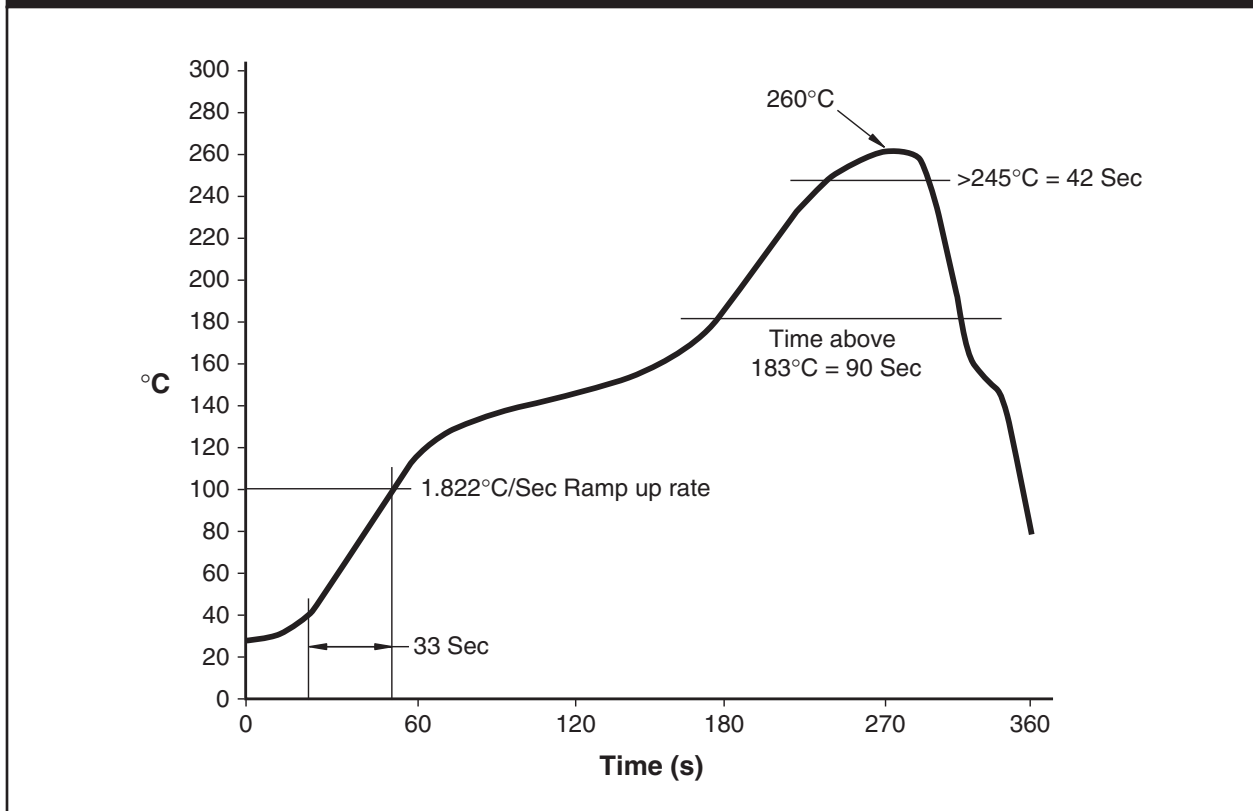

TRADEMARKS

The following are registered and unregistered trademarks Fairchild Semiconductor owns or is authorized to use and is not intended to be an exhaustive list of all such trademarks.

ACEx™	FAST®	IntelliMAX™	POP™	SPM™
ActiveArray™	FASTr™	ISOPLANAR™	Power247™	Stealth™
Bottomless™	FPS™	LittleFET™	PowerEdge™	SuperFET™
CoolFET™	FRFET™	MICROCOUPLER™	PowerSaver™	SuperSOT™-3
CROSSVOLT™	GlobalOptoisolator™	MicroFET™	PowerTrench®	SuperSOT™-6
DOME™	GTO™	MicroPak™	QFET®	SuperSOT™-8
EcoSPARK™	HiSeC™	MICROWIRE™	QS™	SyncFET™
E ² CMOS™	ꞑC™	MSX™	QT Optoelectronics™	TinyLogic®
EnSigna™	i-Lo™	MSXPro™	Quiet Series™	TINYOPTO™
FACT™	ImpliedDisconnect™	OCX™	RapidConfigure™	TruTranslation™
FACT Quiet Series™		OCXPro™	RapidConnect™	UHC™
Across the board. Around the world.™		OPTOLOGIC®	µSerDes™	UltraFET®
The Power Franchise®		OPTOPLANAR™	SILENT SWITCHER®	UniFET™
Programmable Active Droop™		PACMAN™	SMART START™	VCX™

DISCLAIMER

FAIRCHILD SEMICONDUCTOR RESERVES THE RIGHT TO MAKE CHANGES WITHOUT FURTHER NOTICE TO ANY PRODUCTS HEREIN TO IMPROVE RELIABILITY, FUNCTION OR DESIGN. FAIRCHILD DOES NOT ASSUME ANY LIABILITY ARISING OUT OF THE APPLICATION OR USE OF ANY PRODUCT OR CIRCUIT DESCRIBED HEREIN; NEITHER DOES IT CONVEY ANY LICENSE UNDER ITS PATENT RIGHTS, NOR THE RIGHTS OF OTHERS.

LIFE SUPPORT POLICY

FAIRCHILD'S PRODUCTS ARE NOT AUTHORIZED FOR USE AS CRITICAL COMPONENTS IN LIFE SUPPORT DEVICES OR SYSTEMS WITHOUT THE EXPRESS WRITTEN APPROVAL OF FAIRCHILD SEMICONDUCTOR CORPORATION. As used herein:

1. Life support devices or systems are devices or systems which, (a) are intended for surgical implant into the body, or (b) support or sustain life, or (c) whose failure to perform when properly used in accordance with instructions for use provided in the labeling, can be reasonably expected to result in significant injury to the user.
2. A critical component is any component of a life support device or system whose failure to perform can be reasonably expected to cause the failure of the life support device or system, or to affect its safety or effectiveness.

PRODUCT STATUS DEFINITIONS



Definition of Terms

Datasheet Identification	Product Status	Definition
Advance Information	Formative or In Design	This datasheet contains the design specifications for product development. Specifications may change in any manner without notice.
Preliminary	First Production	This datasheet contains preliminary data, and supplementary data will be published at a later date. Fairchild Semiconductor reserves the right to make changes at any time without notice in order to improve design.
No Identification Needed	Full Production	This datasheet contains final specifications. Fairchild Semiconductor reserves the right to make changes at any time without notice in order to improve design.
Obsolete	Not In Production	This datasheet contains specifications on a product that has been discontinued by Fairchild semiconductor. The datasheet is printed for reference information only.

Rev. I15

Looking for pricing, stock, or lifecycle information?

Click below to explore more details on WIN SOURCE:

-  [View FOD063L on WIN SOURCE](#)
-  [Fairchild/ON Semiconductor Information](#)

Optimize Your Supply Chain with WIN SOURCE Solutions

-  Global Sourcing Solution
-  Obsolete Management
-  Cost Control Management
-  Shortage Management
-  Alternative Solution
-  Excess Inventory Management