



# 2.4 GHz High-Power, High-Gain Power Amplifier Module

## SST12LP08A

### Product Brief

The SST12LP08A is a versatile power amplifier based on the highly-reliable InGaP/GaAs HBT technology. Easily configured for linear high-power applications with excellent power-added efficiency while operating over the 2.4- 2.5 GHz frequency band, it typically provides 29 dB gain with 34% power-added efficiency, while meeting 802.11g spectrum mask at 24 dBm. The SST12LP08A also features easy board-level usage along with high-speed power-up/down control through a single combined reference voltage pin and is offered in an 8-contact XSON package.

## Features

- **High Gain:**
  - Typically 29 dB gain across 2.4~2.5 GHz over temperature -40°C to +85°C
- **High linear output power (at 3.3V):**
  - >28 dBm P1dB
  - ~2.5% added EVM up to 20 dBm for 54 Mbps 802.11g signal
  - Meets 802.11g OFDM ACPR requirement up to 24 dBm
  - Meets 802.11b ACPR requirement up to 23.5 dBm
- **High power-added efficiency/Low operating current for both 802.11g/b applications**
  - ~34% @  $P_{OUT} = 24$  dBm for 802.11g
  - ~31% @  $P_{OUT} = 23.5$  dBm for 802.11b
- **Low Shut-down Current (~2  $\mu$ A)**
- **High temperature stability**
  - ~1 dB power variation between -40°C to +85°C
  - ~3 dB gain variation between -40°C to +85°C
- **Temperature and load insensitive on-chip power detector**
  - 20 dB dynamic range
- **Simple input/output matching**
- **Packages available**
  - 8-contact XSON – 2mm x 2mm x 0.45mm
- **All devices are RoHS compliant**

## Applications

- **WLAN (IEEE 802.11b/g/n)**
- **Home RF**
- **Cordless phones**
- **2.4 GHz ISM wireless equipment**

## Block Diagram

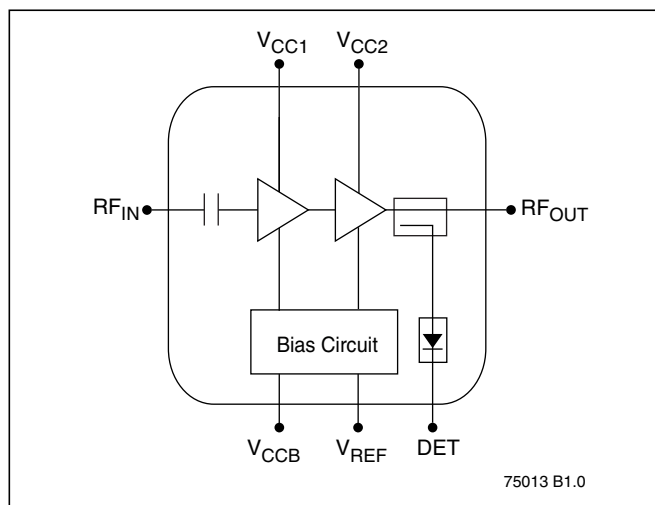

## Product Ordering

### Valid combinations for SST12LP08A

SST12LP08A-QX8E

### SST12LP08A Evaluation Kits

SST12LP08A-QX8E-K

**Note:** Valid combinations are those products in mass production or will be in mass production. Consult your SST sales representative to confirm availability of valid combinations and to determine availability of new combinations.



A Microchip Technology Company

# 2.4 GHz High-Power, High-Gain Power Amplifier Module SST12LP08A

Product Brief

## Contact Information

Thank you for your interest in Microchip RF products. The data sheet for this device contains proprietary information. To obtain a copy of the data sheet, contact your local Microchip sales representative or distributor at the link below.

### Global Sales and Distribution

**Table 1:**Revision History

Revision	Description	Date
A	• Initial release of Product Brief	Jul 2011

ISBN:978-1-61341-445-3

© 2011 Silicon Storage Technology, Inc—a Microchip Technology Company. All rights reserved.

SST, Silicon Storage Technology, the SST logo, SuperFlash, MTP, and FlashFlex are registered trademarks of Silicon Storage Technology, Inc. MPF, SQI, Serial Quad I/O, and Z-Scale are trademarks of Silicon Storage Technology, Inc. All other trademarks and registered trademarks mentioned herein are the property of their respective owners.

Specifications are subject to change without notice. Refer to [www.microchip.com](http://www.microchip.com) for the most recent documentation. For the most current package drawings, please see the Packaging Specification located at <http://www.microchip.com/packaging>.

Memory sizes denote raw storage capacity; actual usable capacity may be less.

SST makes no warranty for the use of its products other than those expressly contained in the Standard Terms and Conditions of Sale.

For sales office locations and information, please see [www.microchip.com](http://www.microchip.com).

---

Silicon Storage Technology, Inc.  
A Microchip Technology Company  
[www.microchip.com](http://www.microchip.com)

---

## Looking for pricing, stock, or lifecycle information?

Click below to explore more details on WIN SOURCE:

- ⊖ [View SST12LP08A-QX8E on WIN SOURCE](#)
- ⊖ [Microchip Technology](#) Information

## Optimize Your Supply Chain with WIN SOURCE Solutions

- ✓ Global Sourcing Solution
- ✓ Obsolete Management
- ✓ Cost Control Management
- ✓ Shortage Management
- ✓ Alternative Solution
- ✓ Excess Inventory Management