



**THE DATASHEET OF  
AD9148BBCZRL**



### FEATURES

- Single-carrier W-CDMA ACLR = 80 dBc at 150 MHz IF
- Channel-to-channel isolation > 90 dB
- Analog output
  - Adjustable 8.7 mA to 31.7 mA
  - $R_L = 25 \Omega$  to  $50 \Omega$
- Novel 2x, 4x, and 8x interpolator eases data interface
- On-chip fine complex NCO allows carrier placement anywhere in DAC bandwidth
- High performance, low noise PLL clock multiplier
- Multiple chip synchronization interface
- Programmable digital inverse sinc filter
- Auxiliary DACs allow for offset control
- Gain DACs allow for I and Q gain matching
- Programmable I and Q phase compensation
- Digital gain control
- Flexible LVDS digital I/F supports 32- or 16-bit bus width
- 196-ball CSP\_BGA, 12 mm x 12 mm

### APPLICATIONS

- Wireless infrastructure
  - LTE, TD-SCDMA, WiMAX, W-CDMA, CDMA2000, GSM
- MIMO/transmit diversity
- Digital high or low IF synthesis

### GENERAL DESCRIPTION

The AD9148 is a quad, 16-bit, high dynamic range, digital-to-analog converter (DAC) that provides a sample rate of 1000 MSPS. This device includes features optimized for direct conversion transmit applications, including gain, phase, and offset compensation. The DAC outputs are optimized to interface seamlessly with analog quadrature modulators such as the ADL5371/ADL5372/ADL5373/ADL5374/ADL5375. A serial peripheral interface (SPI) is provided for programming of the internal device parameters. Full-scale output current can be programmed over a range of 8.7 mA to 31.7 mA. The device operates from 1.8 V and 3.3 V supplies for a total power consumption of 3 W at the maximum sample rate. The AD9148 is enclosed in a 196-ball chip scale package ball grid array with the option of an attached heat spreader.

### PRODUCT HIGHLIGHTS

1. Low noise and intermodulation distortion (IMD) enable high quality synthesis of wideband signals from baseband to high intermediate frequencies.
2. A proprietary DAC output switching technique enhances dynamic performance.
3. The current outputs are easily configured for various single-ended or differential circuit topologies.
4. The LVDS data input interface includes FIFO to ease input timing.

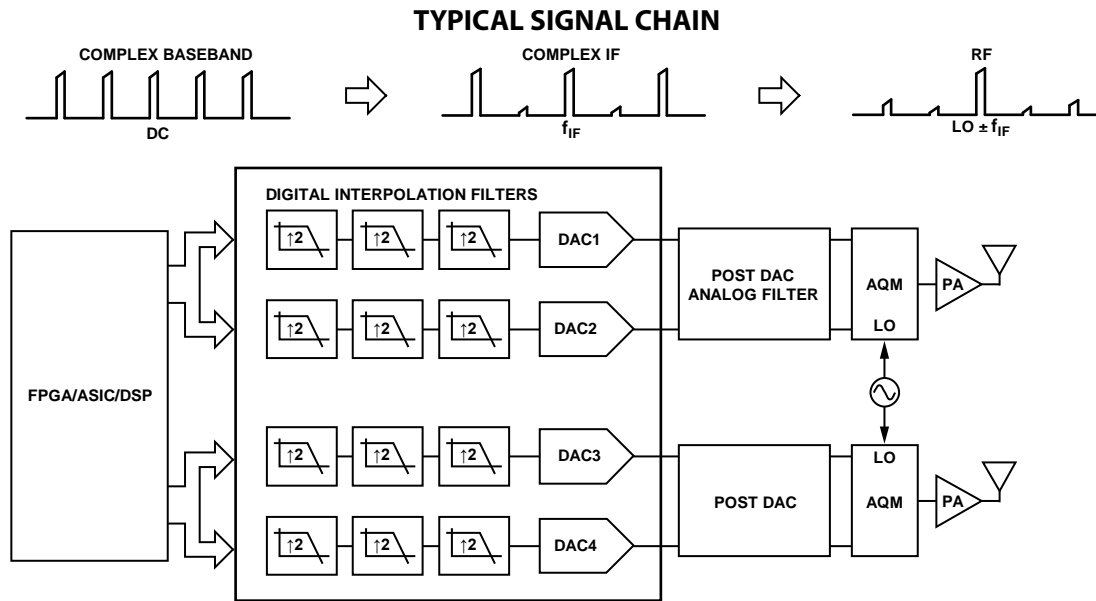

NOTES  
1. AQM = ANALOG QUADRATURE MODULATOR.

Figure 1.

08910-001

#### Rev. B

Information furnished by Analog Devices is believed to be accurate and reliable. However, no responsibility is assumed by Analog Devices for its use, nor for any infringements of patents or other rights of third parties that may result from its use. Specifications subject to change without notice. No license is granted by implication or otherwise under any patent or patent rights of Analog Devices. Trademarks and registered trademarks are the property of their respective owners.

## TABLE OF CONTENTS

Features .....	1	Synchronizing Multiple Devices .....	45
Applications .....	1	Synchronization with Clock Multiplication .....	45
General Description .....	1	Synchronization with Direct Clocking .....	47
Product Highlights .....	1	Additional Synchronization Features .....	48
Typical Signal Chain .....	1	Interface Timing .....	49
Revision History .....	3	Digital Data Path .....	50
Functional Block Diagram .....	4	Premodulation .....	50
Specifications .....	5	Programmable Inverse Sinc Filter .....	50
DC Specifications .....	5	Interpolation Filters .....	51
Input/Output Signal Specifications .....	6	Fine Modulation .....	54
Digital Input Data Timing Specifications .....	7	Quadrature Phase Correction .....	55
AC Specifications .....	8	DC Offset Correction .....	55
Absolute Maximum Ratings .....	9	Digital Gain Control .....	55
Thermal Resistance .....	9	Clock Generation .....	56
Maximum Safe Power Dissipation .....	9	DAC Input Clock Configurations .....	56
ESD Caution .....	9	Driving the CLK_x and REFCLK_x Inputs .....	56
Pin Configurations and Function Descriptions .....	11	Direct Clocking .....	56
Typical Performance Characteristics .....	15	Clock Multiplication .....	57
Terminology .....	21	Analog Outputs .....	59
Serial Peripheral Interface .....	22	Transmit DAC Operation .....	59
General Operation of the Serial Interface .....	22	Auxiliary DAC Operation .....	60
Data Format .....	22	Interfacing to Modulators .....	61
SPI Pin Descriptions .....	22	Device Power Dissipation .....	63
SPI Options .....	23	Temperature Sensor .....	65
SPI Register Map .....	24	Interrupt Request Operation .....	66
SPI Register Descriptions .....	26	Interrupt Service Routine .....	66
Input Data Ports .....	40	Interface Timing Validation .....	67
Dual-Port Mode .....	40	SED Operation .....	67
Single-Port Mode .....	40	SED Example .....	67
Byte Mode .....	41	Example Start-Up Routine .....	68
Data Interface Options .....	41	Derived PLL Settings .....	68
Recommended Frame Input Bias Circuitry .....	41	Derived NCO Settings .....	68
FIFO Operation .....	42	Start-Up Sequence .....	68
Synchronizing and Resetting the FIFO .....	43	Device Verification Sequence .....	68
Monitoring the FIFO Status .....	44	Outline Dimensions .....	69
Device Synchronization .....	45	Ordering Guide .....	70

**REVISION HISTORY****1/12—Rev. A to Rev. B**

Change to Chip ID Default Value, Table 12.....	25
Change to Chip ID Readback Value, Table 13.....	32
Changed 0x02 to 0x0A .....	65

**9/11—Rev. 0 to Rev. A**

Changes to General Description Section .....	1
Deleted Input High Voltage, $V_{IA}$ or $V_{IB}$ Parameter, Table 2, Input Low Voltage, $V_{IA}$ or $V_{IB}$ Parameter, Table 2, and Note 2, Table 2; Renumbered Sequentially .....	6
Added Input Voltage Range, $V_{IA}$ or $V_{IB}$ Parameter, Table 2 .....	6
Changes to Table 10 .....	13
Changes to Figure 41 and Figure 42 .....	23
Changes to 0x1E Addr, Table 12.....	24
Deleted 0x74 Row, Table 12 .....	26
Changes to PLL Control 2, Table 13 .....	29
Changes to HB3 Control, 1E, Bit 7 Row, Table 13 .....	32

Deleted LVDS Pad Ctrl Row, Table 13.....	38
Deleted Frame Input Levels Section and Table 15.....	41
Added Recommended Frame Input Bias Circuitry Section and Figure 45; Renumbered Sequentially.....	41
Changes to Timing Optimization Section .....	48
Added Table 15 .....	48
Changes to Filter Implementation Section .....	50
Changes to Figure 74 .....	57
Deleted Test Access Port Section, Table 27, Figure 92, and Table 28.....	68
Changes to Start-Up Sequence Section .....	68
Deleted Figure 93 .....	69
Deleted Table 29 .....	70

**6/10—Revision 0: Initial Version**

FUNCTIONAL BLOCK DIAGRAM

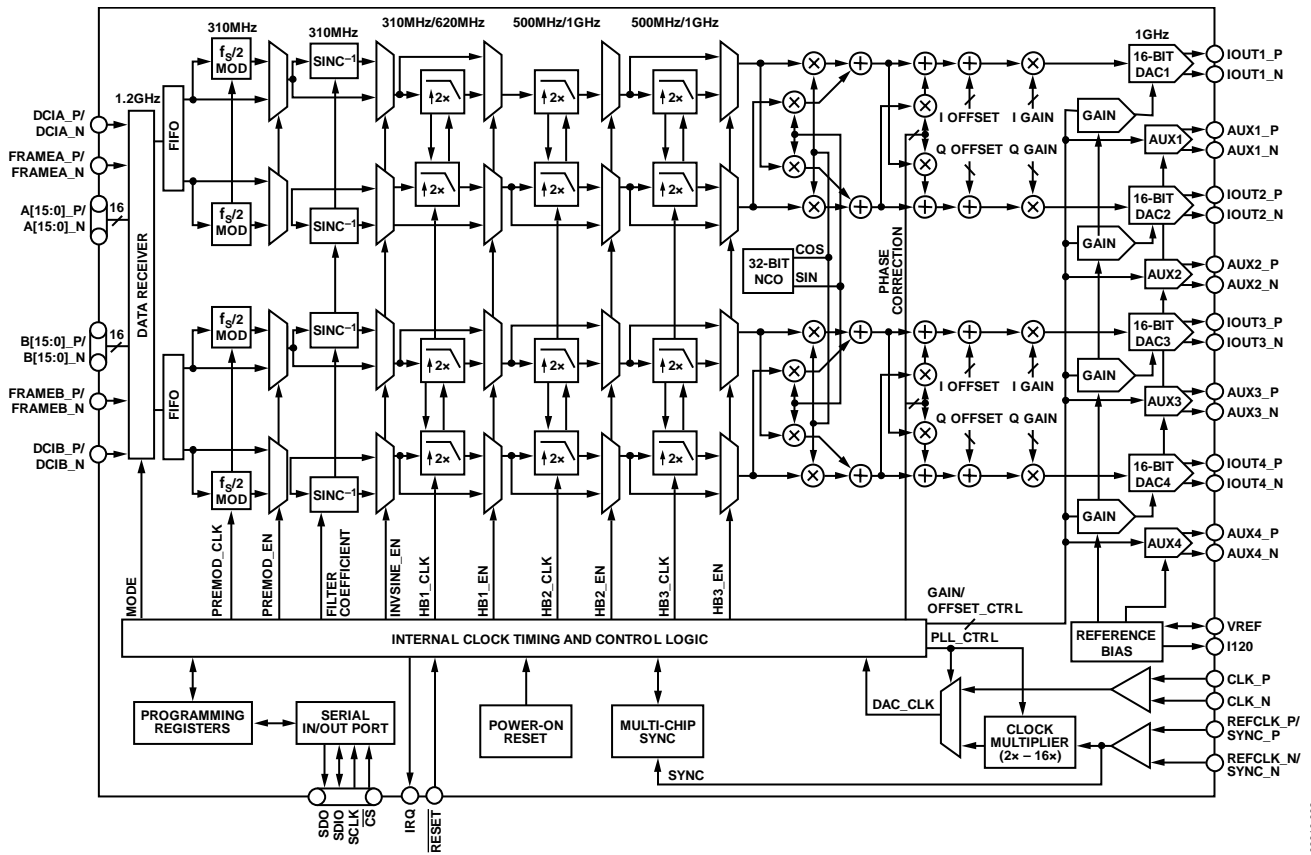

Figure 2.

08910-002

## SPECIFICATIONS

### DC SPECIFICATIONS

$T_{MIN}$  to  $T_{MAX}$ , AVDD33 = 3.3 V, IOVDD = 3.3 V, DVDD18 = 1.8 V, CVDD18 = 1.8 V,  $I_{OUTFS}$  = 20 mA, maximum sample rate, unless otherwise noted.

Table 1.

Parameter	Min	Typ	Max	Unit
RESOLUTION		16		Bits
ACCURACY				
Differential Nonlinearity (DNL)		±2.1		LSB
Integral Nonlinearity (INL)		±3.7		LSB
MAIN DAC OUTPUTS				
Offset Error		±0.001		% FSR
Gain Error (with Internal Reference)		±2		% FSR
Full-Scale Output Current <sup>1</sup>	8.66	20.2	31.66	mA
Output Compliance Range	-1.0		+1.0	V
Output Resistance		10		MΩ
Gain DAC Monotonicity		Guaranteed		
Settling Time to Within ±0.5 LSB		20		ns
TEMPERATURE DRIFT				
Main DAC Offset		0.04		ppm/°C
Main DAC Gain		100		ppm/°C
Reference Voltage		30		ppm/°C
REFERENCE				
Internal Reference Voltage		1.2		V
Output Resistance		5		kΩ
ANALOG SUPPLY VOLTAGES				
AVDD33	3.13	3.3	3.47	V
CVDD18	1.71	1.8	1.89	V
DIGITAL SUPPLY VOLTAGES				
IOVDD	1.71	1.8/3.3	3.47	V
DVDD18	1.71	1.8	1.89	V
POWER CONSUMPTION (NCO OFF, PLL DISABLED, AND SINC <sup>-1</sup> FILTER BYPASSED, UNLESS OTHERWISE NOTED)				
1 × Mode, $f_{DAC}$ = 300 MSPS, $f_{INTERFACE}$ = 600 MSPS		0.79		W
2 × Mode, $f_{DAC}$ = 500 MSPS, $f_{INTERFACE}$ = 500 MSPS		1.49		W
4 × Mode, $f_{DAC}$ = 800 MSPS, $f_{INTERFACE}$ = 400 MSPS		2.18		W
4 × Mode, $f_{DAC}$ = 800 MSPS, $f_{INTERFACE}$ = 400 MSPS, NCO On		2.47		W
4 × Mode, $f_{DAC}$ = 800 MSPS, $f_{INTERFACE}$ = 400 MSPS, PLL Enabled		2.26		W
4 × Mode, $f_{DAC}$ = 800 MSPS, $f_{INTERFACE}$ = 400 MSPS, Sinc <sup>-1</sup> Filter Enabled		2.44		W
8 × Mode, $f_{DAC}$ = 800 MSPS, $f_{INTERFACE}$ = 200 MSPS		2.01	2.16	W
AVDD33		368	373	mW
CVDD18		261	280	mW
IOVDD		0.8	1.6	mW
DVDD18		1377	1504	mW
Power-Down Mode		1	12	mW
OPERATING RANGE	-40	+25	+85	°C

<sup>1</sup> Based on a 10 kΩ external resistor.

## INPUT/OUTPUT SIGNAL SPECIFICATIONS

$T_{MIN}$  to  $T_{MAX}$ , AVDD33 = 3.3 V, IOVDD = 3.3 V, DVDD18 = 1.8 V, CVDD18 = 1.8 V,  $I_{OUTFS} = 20$  mA, maximum sample rate, unless otherwise noted. LVDS driver and receiver are compliant to the IEEE-1596 reduced range link, unless otherwise noted.

Table 2.

Parameter	Min	Typ	Max	Unit
CMOS INPUT LOGIC LEVEL (SCLK, SDIO, $\overline{CS}$ , $\overline{RESET}$ , TMS, TDI, TCK)				
Input $V_{IN}$ Logic High (IOVDD = 1.8 V)	1.2			V
Input $V_{IN}$ Logic High (IOVDD = 3.3 V)	2.0			V
Input $V_{IN}$ Logic Low (IOVDD = 1.8 V)			0.6	V
Input $V_{IN}$ Logic Low (IOVDD = 3.3 V)			0.8	V
CMOS OUTPUT LOGIC LEVEL (SDIO, SDO, $\overline{IRQ}$ , PLL_LOCK, TDO)				
Output $V_{OUT}$ Logic High (IOVDD = 1.8 V)	1.4			V
Output $V_{OUT}$ Logic High (IOVDD = 3.3 V)	2.4			V
Output $V_{OUT}$ Logic Low (IOVDD = 1.8 V)			0.4	V
Output $V_{OUT}$ Logic Low (IOVDD = 3.3 V)			0.4	V
LVDS RECEIVER INPUTS (A[15:0]_x, B[15:0]_x, DCIA_x, DCIB_x)				
Input Voltage Range, $V_{IA}$ or $V_{IB}$	825		1575	mV
Input Differential Threshold, $V_{IDTH}$	-100		+100	mV
Input Differential Hysteresis, $V_{IDTHH}$ to $V_{IDTHL}$		20		mV
Receiver Differential Input Impedance, $R_{IN}$	80		120	$\Omega$
LVDS Input Rate, $f_{INTERFACE}$ (See Table 4)			1200	MSPS
LVDS RECEIVER INPUTS (FRAMEA_x, FRAMEB_x)				
Input Voltage Range, $V_{IA}$ or $V_{IB}$	825		1575	mV
DAC CLOCK INPUT (CLK_P, CLK_N)				
Differential Peak-to-Peak Voltage	100	500	2000	mV
Common-Mode Voltage (Self-Biasing, AC-Coupled)		1.25		V
Maximum Clock Rate	1000			MSPS
REFERENCE CLOCK INPUT (REFCLK_x/SYNC_x)				
Differential Peak-to-Peak Voltage	100	500	2000	mV
Common-Mode Voltage (Self-Biasing, AC-Coupled)		1.25		V
Maximum Clock Rate	500			MSPS
Minimum Clock Rate (PLL Enabled)				
Loop Divider = /2			125	MSPS
Loop Divider = /4			62.5	MSPS
Loop Divider = /8			31.25	MSPS
Loop Divider = /16			15.625	MSPS
SERIAL PERIPHERAL INTERFACE				
Maximum Clock Rate (SCLK)	40			MHz
Minimum Pulse Width High ( $t_{PWH}$ )			12.5	ns
Minimum Pulse Width Low ( $t_{PWL}$ )			12.5	ns
Set-Up Time, SDI to SCLK ( $t_{DS}$ )	1.9			ns
Hold Time, SDI to SCLK ( $t_{DH}$ )	0.2			ns
Data Valid, SDO to SCLK ( $t_{DV}$ )	23			ns
Setup time, $\overline{CS}$ to SCLK ( $t_{DCSB}$ )		1.4		ns

**DIGITAL INPUT DATA TIMING SPECIFICATIONS**

Table 3.

Parameter	Min	Typ	Max	Unit
LATENCY (DACCLK CYCLES)				
1× Interpolation (with or Without Coarse Modulation)		64		Cycles
2× Interpolation (with or Without Coarse Modulation)		125		Cycles
4× Interpolation (with or Without Coarse Modulation)		254		Cycles
8× Interpolation (with or Without Coarse Modulation)		508		Cycles
Inverse Sinc (1× Interpolation)		10		Cycles
Inverse Sinc (2× Interpolation)		20		Cycles
Inverse Sinc (4× Interpolation)		40		Cycles
Inverse Sinc (8× Interpolation)		80		Cycles
Fine Modulation		12		Cycles
Power-Up Time		100		ms

Table 4. Maximum Rate

Interface Mode	Maximum Rate (MSPS)					
	$f_{\text{INTERFACE}}$	$f_{\text{DATA}}$	$f_{\text{HB1}}$	$f_{\text{HB2}}$	$f_{\text{HB3}}$	$f_{\text{DAC}}$
Dual Port Mode	620	310	620	1000	1000	1000
Single Port Mode or Byte Mode	1200	300	600	1000	1000	1000

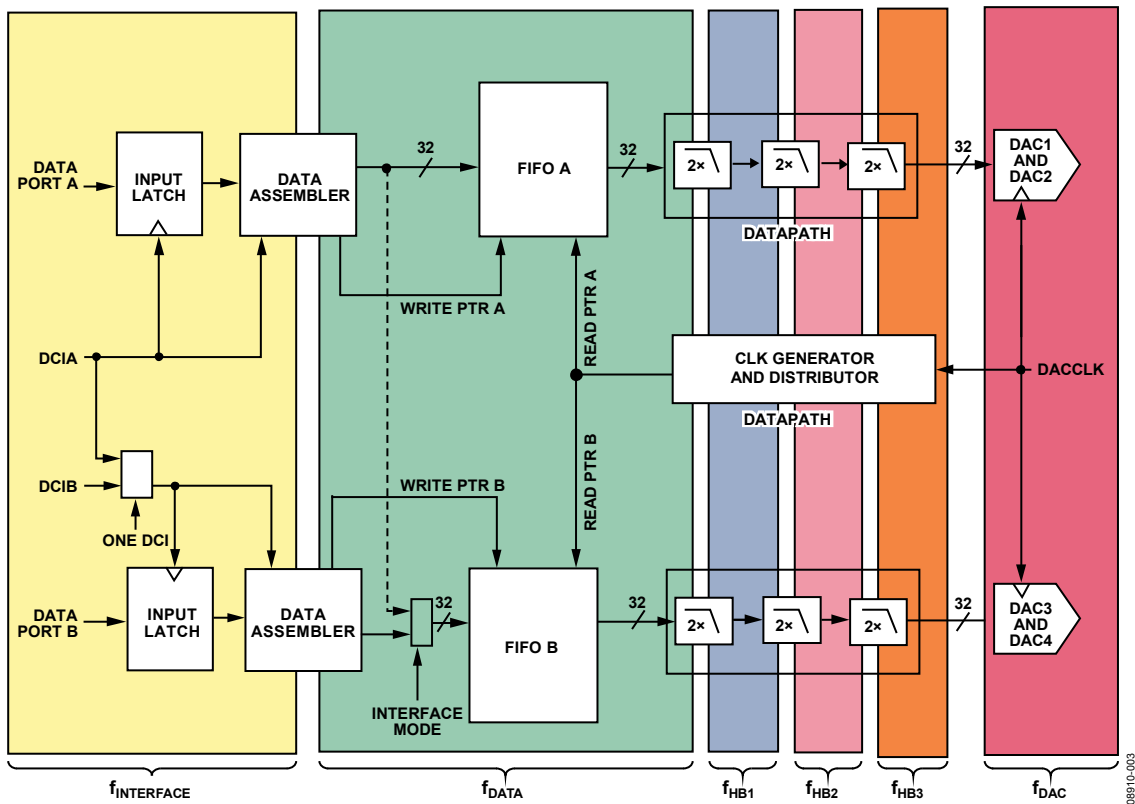

Figure 3. Defining Maximum Rates

**AC SPECIFICATIONS**

$T_{MIN}$  to  $T_{MAX}$ , AVDD33 = 3.3 V, IOVDD = 3.3 V, DVDD18 = 1.8 V, CVDD18 = 1.8 V,  $I_{OUTFS} = 20$  mA, maximum sample rate, unless otherwise noted.

**Table 5.**

Parameter	Min	Typ	Max	Unit
SPURIOUS-FREE DYNAMIC RANGE (SFDR)				
$f_{DAC} = 400$ MSPS, $f_{OUT} = 80$ MHz		72		dBc
$f_{DAC} = 600$ MSPS, $f_{OUT} = 100$ MHz		67		dBc
$f_{DAC} = 1000$ MSPS, $f_{OUT} = 100$ MHz		65		dBc
TWO-TONE INTERMODULATION DISTORTION (IMD)				
$f_{DAC} = 400$ MSPS, $f_{OUT} = 100$ MHz		85		dBc
$f_{DAC} = 600$ MSPS, $f_{OUT} = 120$ MHz		82		dBc
$f_{DAC} = 1000$ MSPS, $f_{OUT} = 150$ MHz		76		dBc
NOISE SPECTRAL DENSITY (NSD) EIGHT-TONE, 500 kHz TONE SPACING				
$f_{DAC} = 200$ MSPS, $f_{OUT} = 80$ MHz		-160		dBm/Hz
$f_{DAC} = 400$ MSPS, $f_{OUT} = 100$ MHz		-161		dBm/Hz
$f_{DAC} = 800$ MSPS, $f_{OUT} = 100$ MHz		-162.5		dBm/Hz
W-CDMA ADJACENT CHANNEL LEAKAGE RATIO (ACL), SINGLE CARRIER				
$f_{DAC} = 737.28$ MSPS, $f_{OUT} = 100$ MHz, PLL Off		-81		dBc
$f_{DAC} = 737.28$ MSPS, $f_{OUT} = 100$ MHz, PLL On		-78		dBc
$f_{DAC} = 737.28$ MSPS, $f_{OUT} = 200$ MHz, PLL Off		-79		dBc
$f_{DAC} = 737.28$ MSPS, $f_{OUT} = 200$ MHz, PLL On		-72.5		dBc
W-CDMA ALTERNATE CHANNEL LEAKAGE RATIO, SINGLE CARRIER				
$f_{DAC} = 737.28$ MSPS, $f_{OUT} = 100$ MHz, PLL Off		-87		dBc
$f_{DAC} = 737.28$ MSPS, $f_{OUT} = 100$ MHz, PLL On		-83		dBc
$f_{DAC} = 737.28$ MSPS, $f_{OUT} = 200$ MHz, PLL Off		-84		dBc
$f_{DAC} = 737.28$ MSPS, $f_{OUT} = 200$ MHz, PLL On		-80.5		dBc

## ABSOLUTE MAXIMUM RATINGS

Table 6.

Parameter	With Respect To	Rating
AVDD33, IOVDD	AGND, DGND, CGND	−0.3 V to +3.6 V
DVDD18, CVDD18	AGND, DGND, CGND	−0.3 V to +2.10 V
AGND	DGND, CGND	−0.3 V to +0.3 V
DGND	AGND, CGND	−0.3 V to +0.3 V
CGND	AGND, DGND	−0.3 V to +0.3 V
I120, VREF	AGND	−0.3 V to AVDD33 + 0.3 V
IOUT1_P, IOUT1_N, IOUT2_P, IOUT2_N, IOUT3_P, IOUT3_N, IOUT4_P, IOUT4_N	AGND	−1.0 V to AVDD33 + 0.3 V
A15_P to A0_P, A15_N to A0_N, B15_P to B0_P, B15_N, B0_N	DGND	−0.3 V to DVDD18 + 0.3 V
DCIA_P, DCIA_N, FRAMEA_P, FRAMEA_N, DCIB_P, DCIB_N, FRAMEB_P, FRAMEB_N	DGND	−0.3 V to DVDD18 + 0.3 V
CLK_P, CLK_N, REFCLK_P, REFCLK_N	CGND	−0.3 V to CVDD18 + 0.3 V
CSB, SCLK, SDIO, SDO, TDO, TDI, TCK, TMS, RESET, IRQ, PLL_LOCK	DGND	−0.3 V to IOVDD + 0.3 V
Junction Temperature		125°C
Storage Temperature Range		−65°C to +150°C

Stresses above those listed under Absolute Maximum Ratings may cause permanent damage to the device. This is a stress rating only; functional operation of the device at these or any other conditions above those indicated in the operational section of this specification is not implied. Exposure to absolute maximum rating conditions for extended periods may affect device reliability.

### THERMAL RESISTANCE

Typical  $\theta_{JA}$ ,  $\theta_{JB}$ , and  $\theta_{JC}$  are specified vs. the number of PCB layers in still air for each package offering. Airflow increases heat dissipation effectively reducing  $\theta_{JA}$  and  $\theta_{JB}$ .

Table 7. Thermal Resistance

Package Type	$\theta_{JA}$	$\theta_{JB}$	$\theta_{JC}$	Unit	Notes
196-Ball CSP_BGA	24.7	12.6	5.7	°C/W	4-layer board, 25 PCB vias
	19.2	10.9	5.3	°C/W	8-layer board, 25 PCB vias
	18.1	10.5	5.3	°C/W	10-layer board, 25 PCB vias
	18.0	10.5	5.3	°C/W	12-layer board, 25 PCB vias
196-Ball BGA_ED	20.9	8.6	3.1	°C/W	4-layer board, 25 PCB vias
	16.2	7.7	3.1	°C/W	8-layer board, 25 PCB vias
	15.2	7.4	3.1	°C/W	10-layer board, 25 PCB vias
	15.0	7.4	3.1	°C/W	12-layer board, 25 PCB vias

### MAXIMUM SAFE POWER DISSIPATION

The maximum junction temperature for the AD9148 is 125°C. With the thermal resistance of the molded package (CSP\_BGA) given for a 12 layer board, the maximum power that can be dissipated in this package can be calculated as

$$Power_{MAX} = \frac{(T_J - T_A)}{\theta_{JA}} = \frac{(125 - 85)}{18.0} = 2.22 \text{ W}$$

To increase the maximum power, the AD9148 is available in a second package option (BGA\_ED), which includes a heat spreader on top of the package. Also, an external heat sink can be attached to the top of the AD9148 CSP\_BGA package. The adjusted maximum power for each of these conditions is shown in Table 8.

With the thermal resistance of the heat spreader package (BGA\_ED) given for a 12-layer board, the maximum power that can be dissipated in this package can be calculated as

$$Power_{MAX} = \frac{(T_J - T_A)}{\theta_{JA}} = \frac{(125 - 85)}{15.0} = 2.67 \text{ W}$$

To increase the maximum power, an external heat sink can be attached to the top of the AD9148 BGA\_ED package. The adjusted maximum power for an external heat sink is shown in Table 8.

To aid in the selection of package, the maximum  $f_{DAC}$  rate for a given power dissipation over several operating conditions is shown in Table 9. The maximum  $f_{DAC}$  rate applies to all interpolation rates. Note that, if the programmable inverse sinc filter is enabled, the maximum  $f_{DAC}$  rate specified in Table 9 decreases.

### ESD CAUTION



**ESD (electrostatic discharge) sensitive device.** Charged devices and circuit boards can discharge without detection. Although this product features patented or proprietary protection circuitry, damage may occur on devices subjected to high energy ESD. Therefore, proper ESD precautions should be taken to avoid performance degradation or loss of functionality.

Table 8. Thermal Resistance and Maximum Power

Package Type	T <sub>A</sub> (°C)	PCB			Case	T <sub>J</sub> (°C)	θ <sub>JA</sub> (°C/W)	Maximum Power (W)
		PCB Layers	PCB Vias	External Heat Sink <sup>1</sup>				
196-ball CSP_BGA	85	12	25	No	CSP_BGA	125	18.0	2.22
196-ball CSP_BGA	85	12	25	Yes	CSP_BGA	125	16.0	2.50
196-ball BGA_ED	85	12	25	No	BGA_ED	125	15.0	2.67
196-ball BGA_ED	85	12	25	Yes	BGA_ED	125	14.0	2.86

<sup>1</sup> Heat sink is used in the thermal model: 13 mm × 13 mm, 15 mm tall.

Table 9. Power vs. f<sub>DAC</sub> Rate and Functionality

Maximum Power (W)	Package	Heat-Sink Combination <sup>2</sup>	Maximum f <sub>DAC</sub> (MSPS) <sup>1</sup>			
			Coarse Modulation		Fine Modulation (NCO)	
			PLL Off	PLL On	PLL Off	PLL On
2.22	CSP_BGA	No	820	740	695	630
2.50	CSP_BGA	Yes	950	875	810	740
2.67	BGA_EP	No	1000	945	870	810
2.86	BGA_EP	Yes	1000	1000	940	870

<sup>1</sup> Typical maximum f<sub>DAC</sub> rate with inverse sinc filter off.

<sup>2</sup> Heat sink is used in the thermal model: 13 mm × 13 mm, 15 mm tall.

### PIN CONFIGURATIONS AND FUNCTION DESCRIPTIONS

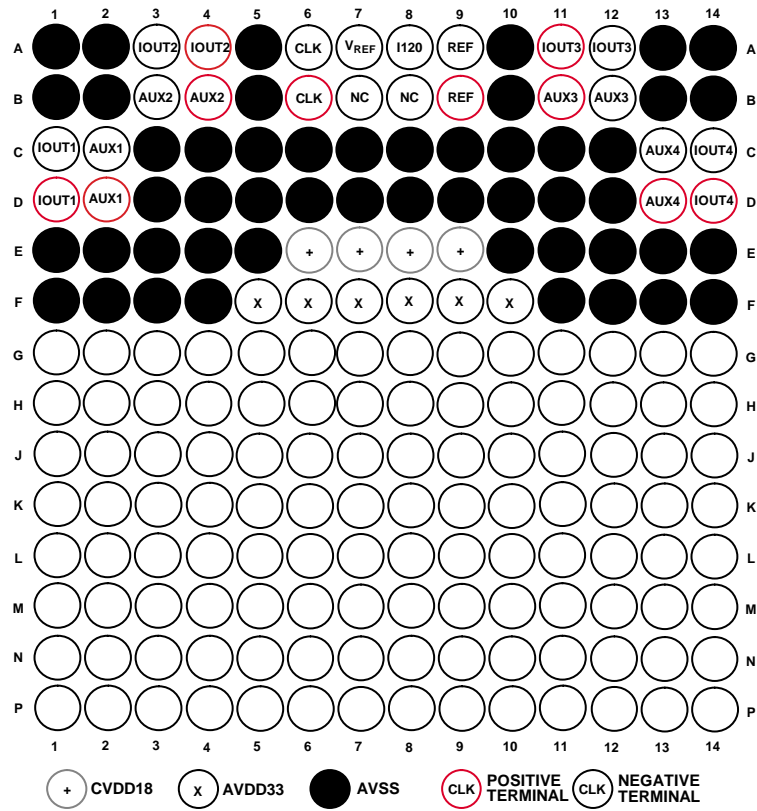

Figure 4. Pin Configuration (Top View), Analog and Clock Domain Pins

08810-004

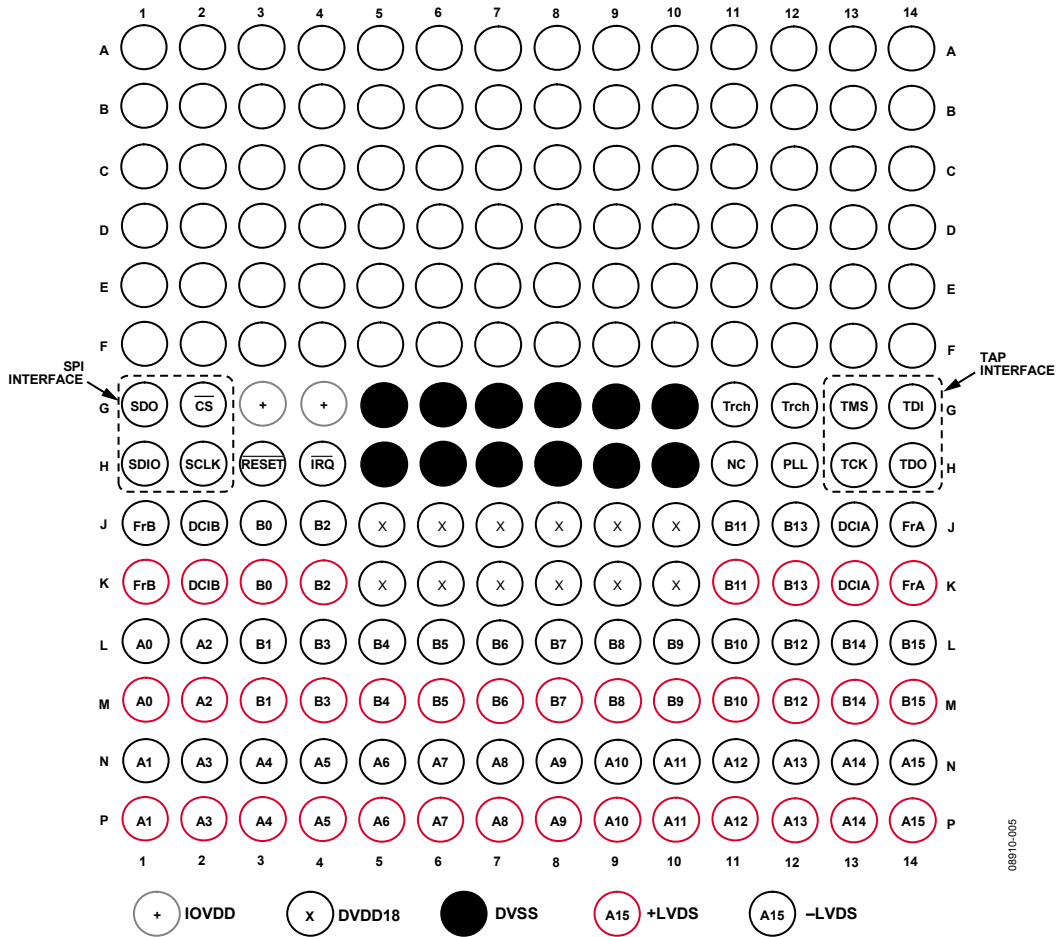

Figure 5. Pin Configuration (Top View), Digital Domain Pins

Table 10. Pin Function Description

Pin No.	Mnemonic	Description
E6, E7, E8, E9	CVDD18	1.8 V Clock Supply.
F5, F6, F7, F8, F9, F10	AVDD33	3.3 V Analog Supply.
A1, A2, A5, A10, A13, A14, B1, B2, B5, B10, B13, B14, C3, C4, C5, C6, C7, C8, C9, C10, C11, C12, D3, D4, D5, D6, D7, D8, D9, D10, D11, D12, E1, E2, E3, E4, E5, E10, E11, E12, E13, E14, F1, F2, F3, F4, F11, F12, F13, F14	AVSS	Analog Supply Ground.
G5, G6, G7, G8, G9, G10, H5, H6, H7, H8, H9, H10	DVSS	Digital Supply Ground.
G3, G4	IOVDD	Supply for Serial Ports (SPI and TAP), $\overline{\text{RESET}}$ and $\overline{\text{IRQ}}$ . 1.8 V to 3.3 V can be supplied to these pins.
J5, J6, J7, J8, J9, J10, K5, K6, K7, K8, K9, K10	DVDD18	1.8 V Digital Supply.
B7, B8, H11	NC	No Connect. Do not connect to this pin.
C1	IOOUT1_N	DAC 1 Complementary Output Current.
D1	IOOUT1_P	DAC 1 Positive Output Current.
A3	IOOUT2_N	DAC 2 Complementary Output Current.
A4	IOOUT2_P	DAC 2 Positive Output Current.
A11	IOOUT3_P	DAC 3 Positive Output Current.
A12	IOOUT3_N	DAC 3 Complementary Output Current.

Pin No.	Mnemonic	Description
C14	IOUT4_N	DAC 4 Complementary Output Current.
D14	IOUT4_P	DAC 4 Positive Output Current.
C2	AUX1_N	Auxiliary DAC 1 Complementary Output Current.
D2	AUX1_P	Auxiliary DAC 1 Positive Output Current.
B3	AUX2_N	Auxiliary DAC 2 Complementary Output Current.
B4	AUX2_P	Auxiliary DAC 2 Positive Output Current.
B11	AUX3_P	Auxiliary DAC 3 Positive Output Current.
B12	AUX3_N	Auxiliary DAC 3 Complementary Output Current.
C13	AUX4_N	Auxiliary DAC 4 Complementary Output Current.
D13	AUX4_P	Auxiliary DAC 4 Positive Output Current.
A8	I120	Tie to analog ground via a 10 k $\Omega$ resistor to generate a 120 $\mu$ A reference current.
A7	VREF	Band Gap Voltage Reference I/O. Decouple to analog ground via a 0.1 $\mu$ F capacitor. Output impedance is approximately 5 k $\Omega$ .
B6, A6	CLK_P/CLK_N	Positive/Negative DAC Clock Input (CLK).
B9, A9	REFCLK_P/REFCLK_N or SYNC_P/SYNC_N	PLL Reference Clock Input (REFCLK_x). This pin has a secondary function as a synchronization input (SYNC_x).
H4	$\overline{\text{IRQ}}$	Active Low Open-Drain Interrupt Request Output. Pull up to IOVDD with a 10 k $\Omega$ resistor.
H3	$\overline{\text{RESET}}$	An active low LVCMOS input resets the device. Pull up to IOVDD.
G1	SDO	Serial Data Output for SPI.
G2	$\overline{\text{CS}}$	Active Low Chip Select for SPI.
H1	SDIO	Serial Data Input/Output for SPI.
H2	SCLK	Qualifying Clock Input for SPI.
G11, G12	TRENCH	Connect this pin to VSS.
H12	PLL_LOCK	Active High LVCMOS Output. It indicates the lock status of the PLL circuitry.
G13	TMS	Reserved for Future Use. Connect to DVSS.
G14	TDI	Reserved for Future Use. Connect to DVSS.
H13	TCK	Reserved for Future Use. Connect to DVSS.
H14	TDO	Reserved for Future Use. Leave unconnected.
M1, L1	A0_P/A0_N	LVDS Data Input Pair, Port A (LSB).
P1, N1	A1_P/A1_N	LVDS Data Input Pair, Port A.
M2, L2	A2_P/A2_N	LVDS Data Input Pair, Port A.
P2, N2	A3_P/A3_N	LVDS Data Input Pair, Port A.
P3, N3	A4_P/A4_N	LVDS Data Input Pair, Port A.
P4, N4	A5_P/A5_N	LVDS Data Input Pair, Port A.
P5, N5	A6_P/A6_N	LVDS Data Input Pair, Port A.
P6, N6	A7_P/A7_N	LVDS Data Input Pair, Port A.
P7, N7	A8_P/A8_N	LVDS Data Input Pair, Port A.
P8, N8	A9_P/A9_N	LVDS Data Input Pair, Port A.
P9, N9	A10_P/A10_N	LVDS Data Input Pair, Port A.
P10, N10	A11_P/A11_N	LVDS Data Input Pair, Port A.
P11, N11	A12_P/A12_N	LVDS Data Input Pair, Port A.
P12, N12	A13_P/A13_N	LVDS Data Input Pair, Port A.
P13, N13	A14_P/A14_N	LVDS Data Input Pair, Port A.
P14, N14	A15_P/A15_N	LVDS Data Input Pair, Port A (MSB).
K13, J13	DCIA_P/DCIA_N	LVDS Data Clock Input Pair for Port A.
K14, J14	FRAMEA_P/FRAMEA_N	LVDS Frame Input for Port A. Tie to LVDS logic low if not used. Recommended external bias circuit is shown in Figure 49.
K3, J3	B0_P/B0_N	LVDS Data Input Pair, Port B (LSB).
M3, L3	B1_P/B1_N	LVDS Data Input Pair, Port B.
K4, J4	B2_P/B2_N	LVDS Data Input Pair, Port B.
M4, L4	B3_P/B3_N	LVDS Data Input Pair, Port B.
M5, L5	B4_P/B4_N	LVDS Data Input Pair, Port B.
M6, L6	B5_P/B5_N	LVDS Data Input Pair, Port B.

Pin No.	Mnemonic	Description
M7, L7	B6_P/B6_N	LVDS Data Input Pair, Port B.
M8, L8	B7_P/B7_N	LVDS Data Input Pair, Port B.
M9, L9	B8_P/B8_N	LVDS Data Input Pair, Port B.
M10, L10	B9_P/B9_N	LVDS Data Input Pair, Port B.
M11, L11	B10_P/B10_N	LVDS Data Input Pair, Port B.
K11, J11	B11_P/B11_N	LVDS Data Input Pair, Port B.
M12, L12	B12_P/B12_N	LVDS Data Input Pair, Port B.
K12, J12	B13_P/B13_N	LVDS Data Input Pair, Port B.
M13, L13	B14_P/B14_N	LVDS Data Input Pair, Port B.
M14, L14	B15_P/B15_N	LVDS Data Input Pair, Port B (MSB).
K2, J2	DCIB_P/DCIB_N	LVDS Data Clock Input Pair for Port B.
K1, J1	FRAMEB_P/FRAMEB_N	LVDS Frame Input for Port B. Tie to LVDS logic low if not used. Recommended external bias circuit is shown in Figure 49.

### TYPICAL PERFORMANCE CHARACTERISTICS

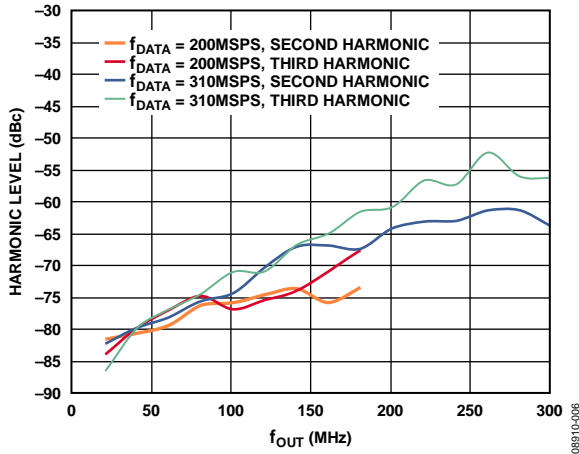

Figure 6. Harmonic Level vs.  $f_{OUT}$  over  $f_{DATA}$ , 2x Interpolation, Digital Scale = 0 dBFS, Full-Scale Current = 20 mA

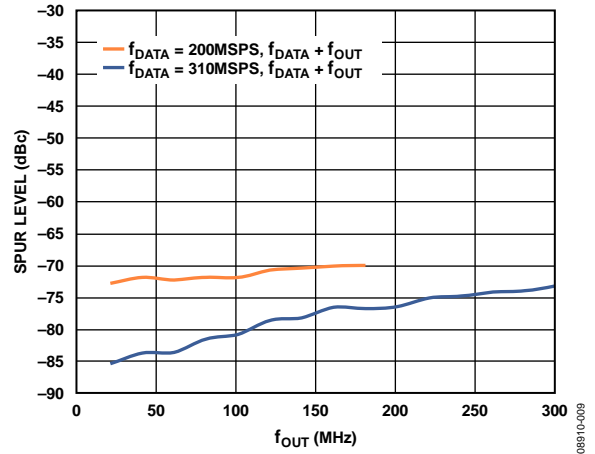

Figure 9. Highest Digital Spur vs.  $f_{OUT}$  over  $f_{DATA}$ , 2x Interpolation, Digital Scale = 0 dBFS, Full-Scale Current = 20 mA

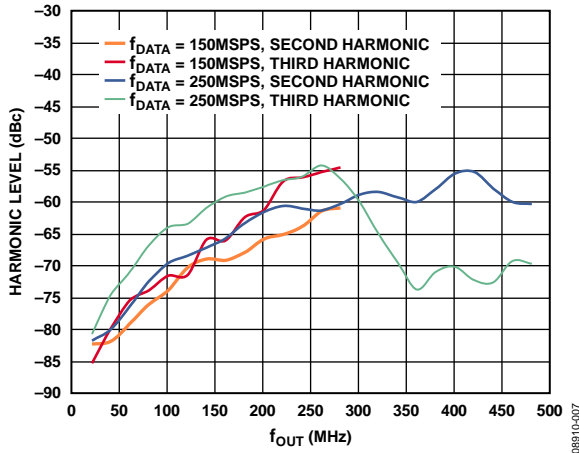

Figure 7. Harmonic Level vs.  $f_{OUT}$  over  $f_{DATA}$ , 4x Interpolation, Digital Scale = 0 dBFS, Full-Scale Current = 20 mA

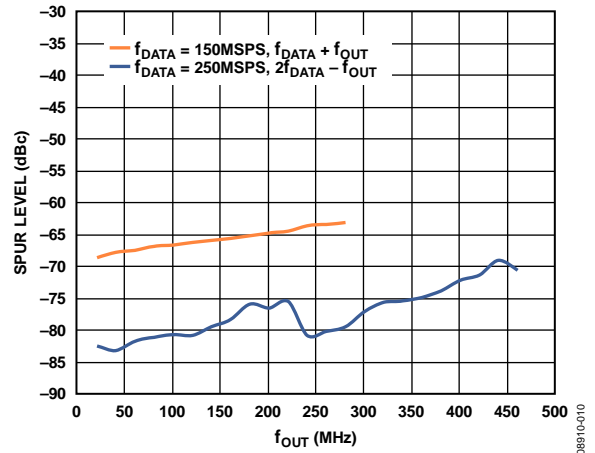

Figure 10. Highest Digital Spur vs.  $f_{OUT}$  over  $f_{DATA}$ , 4x Interpolation, Digital Scale = 0 dBFS, Full-Scale Current = 20 mA

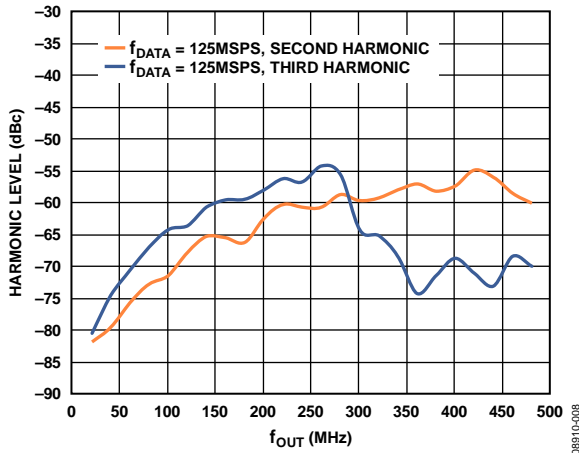

Figure 8. Harmonic Level vs.  $f_{OUT}$ , 8x Interpolation over  $f_{DATA} = 125$  MSPS, Digital Scale = 0 dBFS, Full-Scale Current = 20 mA

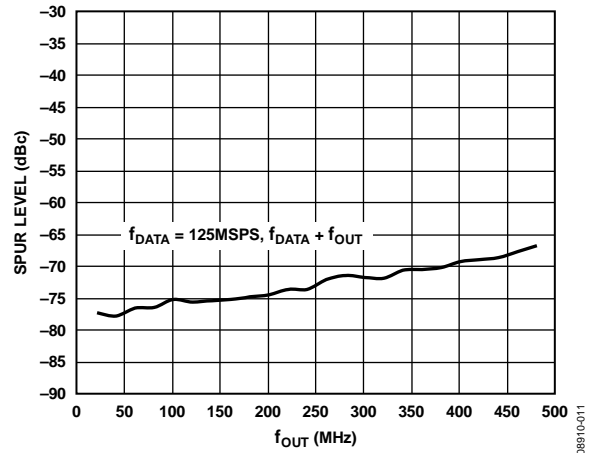

Figure 11. Highest Digital Spur vs.  $f_{OUT}$ , 8x Interpolation,  $f_{DATA} = 125$  MSPS, Digital Scale = 0 dBFS, Full-Scale Current = 20 mA

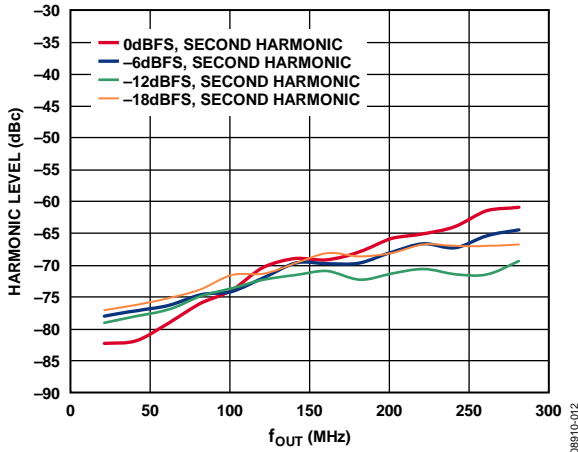

Figure 12. Second Harmonic vs.  $f_{OUT}$  over Digital Scale, Full-Scale Current = 20 mA, 4× Interpolation,  $f_{DATA} = 150$  MSPS

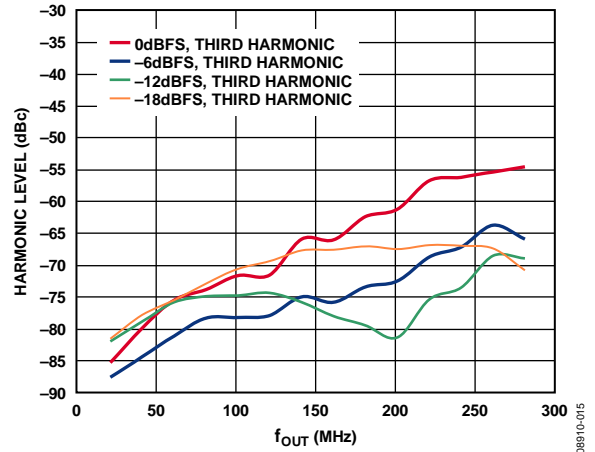

Figure 15. Third Harmonic vs.  $f_{OUT}$  over Digital Scale, Full-Scale Current = 20 mA, 4× Interpolation,  $f_{DATA} = 150$  MSPS

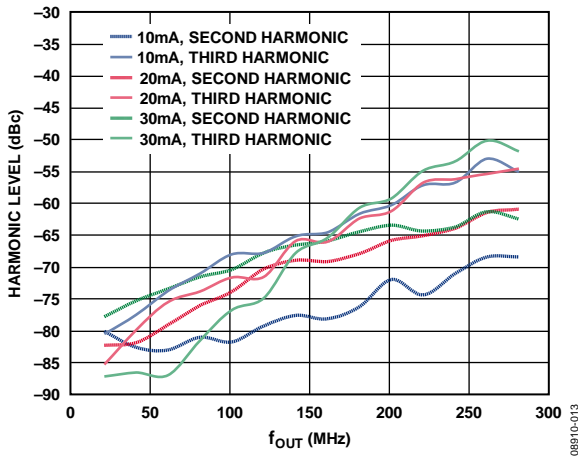

Figure 13. Second Harmonic vs.  $f_{OUT}$  over Full-Scale Current, Digital Scale = 0 dBFS, 4× Interpolation,  $f_{DATA} = 150$  MSPS

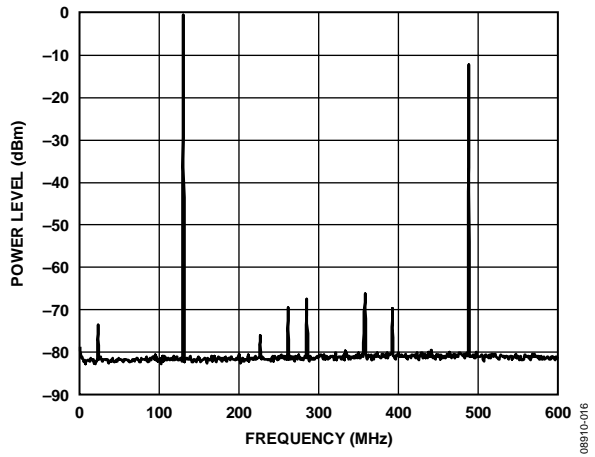

Figure 16. 2× Interpolation,  $f_{DATA} = 310$  MSPS,  $f_{OUT} = 131$  MHz

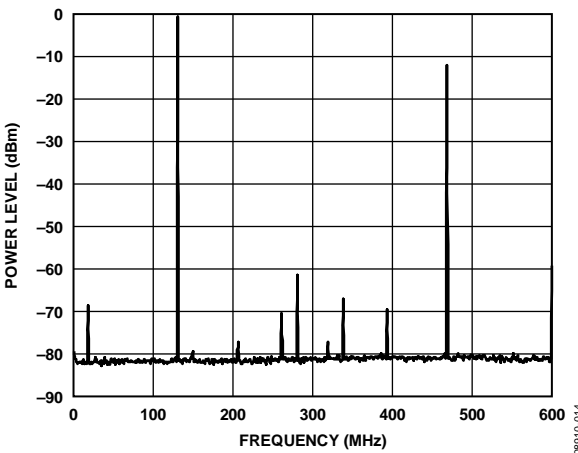

Figure 14. 4× Interpolation,  $f_{DATA} = 150$  MSPS,  $f_{OUT} = 131$  MHz

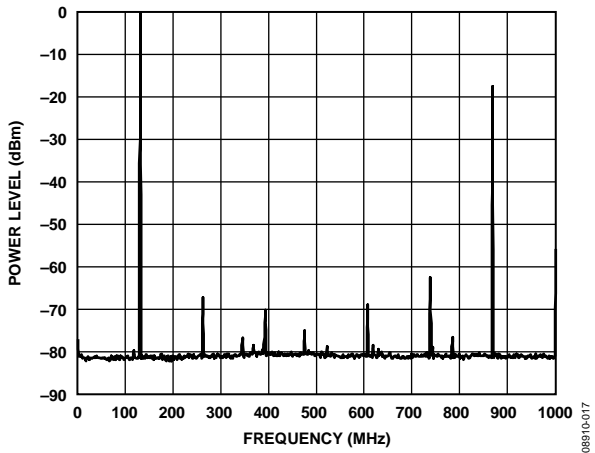

Figure 17. 8× Interpolation,  $f_{DATA} = 125$  MSPS,  $f_{OUT} = 131$  MHz

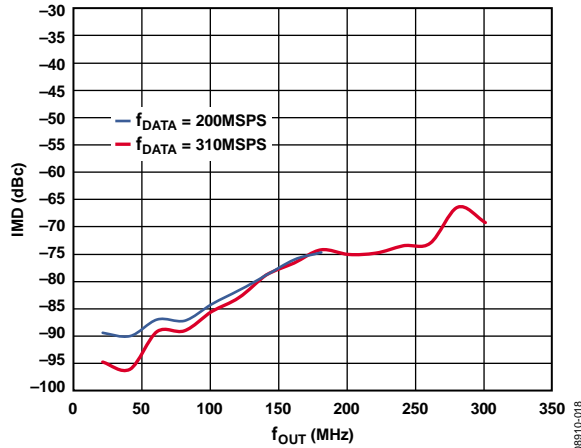

Figure 18. IMD vs.  $f_{OUT}$  over  $f_{DATA}$ , 2x Interpolation, Digital Scale = 0 dBFS, Full-Scale Current = 20 mA

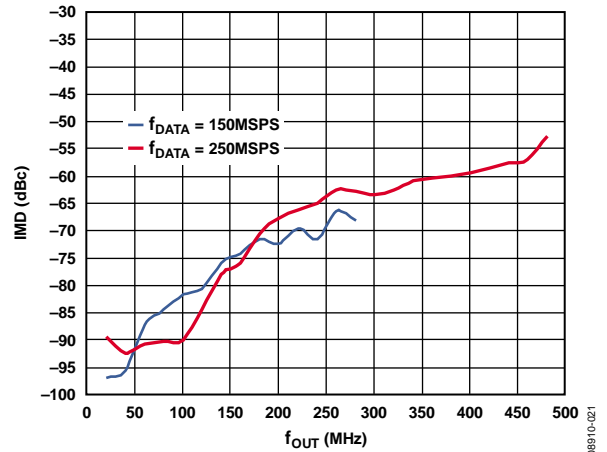

Figure 21. IMD vs.  $f_{OUT}$  over  $f_{DATA}$ , 4x Interpolation, Digital Scale = 0 dBFS, Full-Scale Current = 20 mA

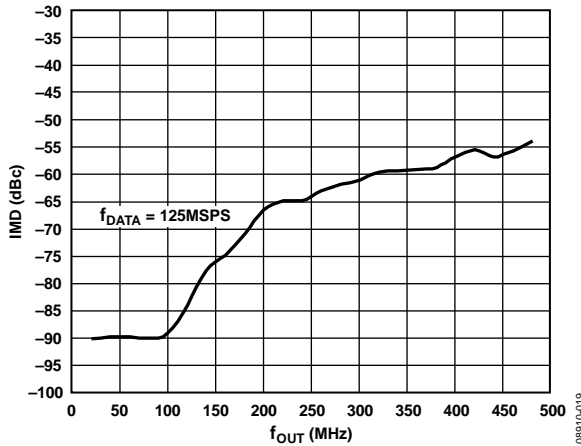

Figure 19. IMD vs.  $f_{OUT}$ , 8x Interpolation,  $f_{DATA} = 125$  MSPS, Digital Scale = 0 dBFS, Full-Scale Current = 20 mA

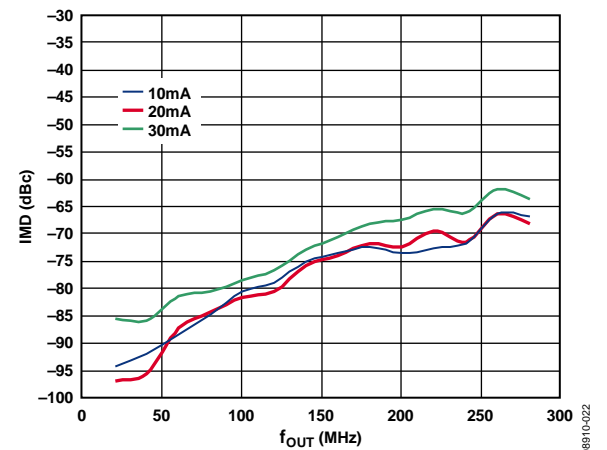

Figure 22. IMD vs.  $f_{OUT}$  over Full-Scale Current, 4x Interpolation,  $f_{DATA} = 150$  MSPS, Digital Scale = 0 dBFS

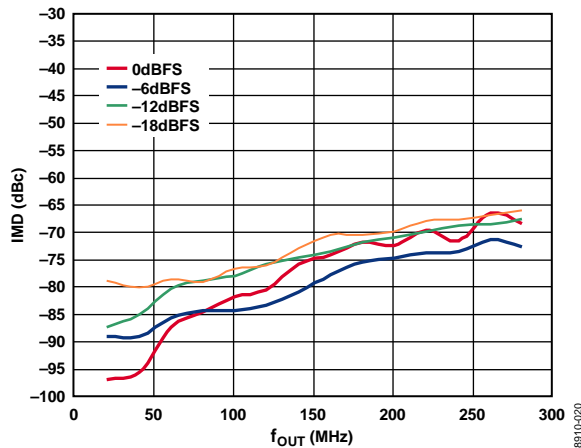

Figure 20. IMD vs.  $f_{OUT}$  over Digital Scale, 4x Interpolation,  $f_{DATA} = 150$  MSPS, Full-Scale Current = 20 mA

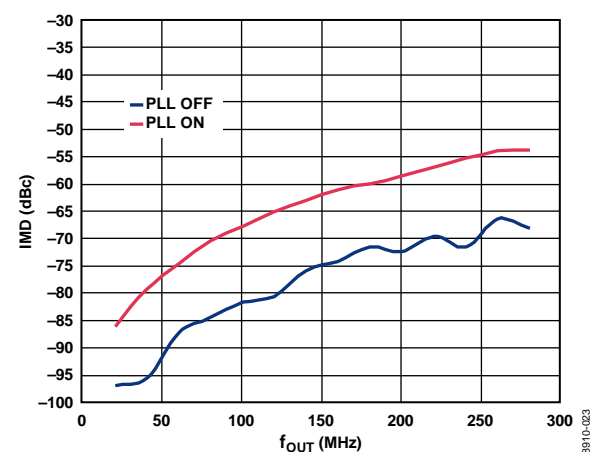

Figure 23. IMD vs.  $f_{OUT}$ , PLL On and Off, Digital Scale = 0 dBFS, Full-Scale Current = 20 mA

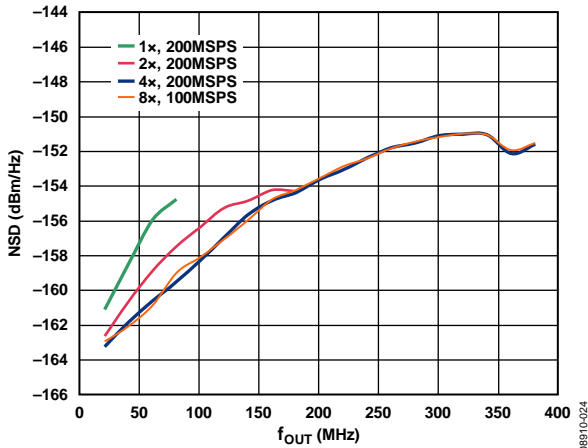

Figure 24. Single-Tone NSD Performance vs.  $f_{OUT}$ , Digital Scale = 0 dBFS,  $4 \times f_{DATA} = 200$  MSPS, Full-Scale Current = 20 mA

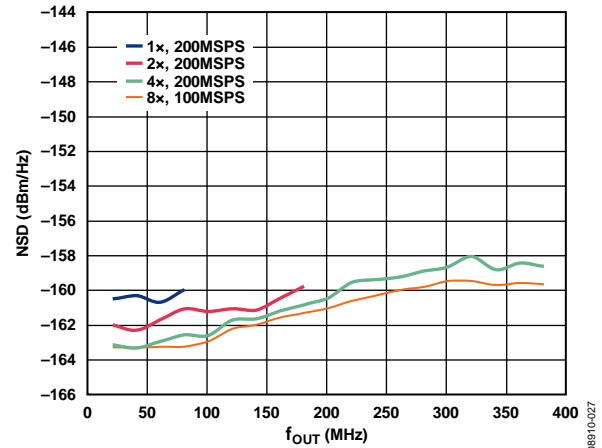

Figure 27. Eight-Tone NSD Performance vs.  $f_{OUT}$ , Digital Scale = 0 dBFS, Full-Scale Current = 20 mA

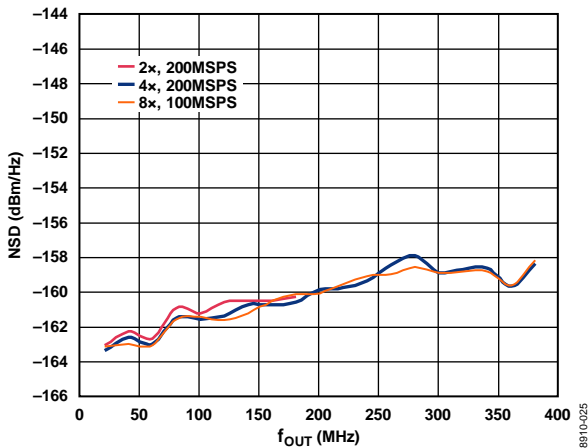

Figure 25. Single-Tone NSD Performance vs.  $f_{OUT}$ , Digital Scale = 0 dBFS,  $4 \times f_{DATA} = 200$  MSPS, Full-Scale Current = 20 mA, PLL On

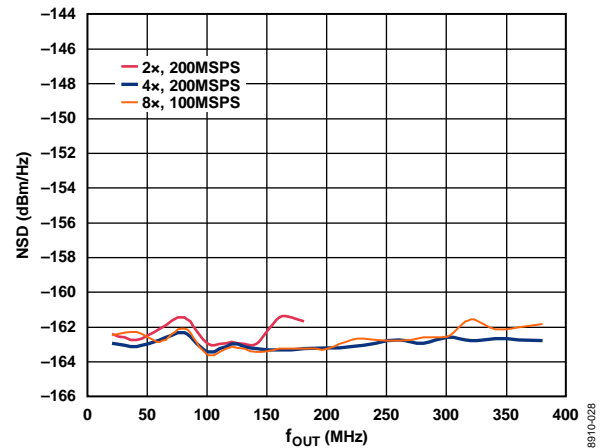

Figure 28. Single-Tone NSD Performance vs.  $f_{OUT}$ , Digital Scale = 0 dBFS, Full-Scale Current = 20 mA, PLL On

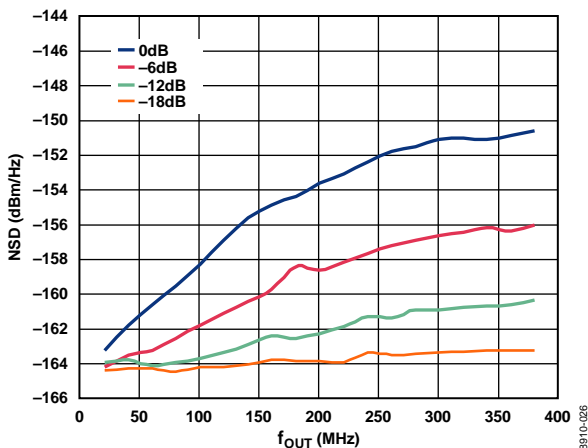

Figure 26. Single-Tone NSD Performance vs.  $f_{OUT}$  over Digital Scale,  $4 \times f_{DATA} = 200$  MSPS, Full-Scale Current = 20 mA

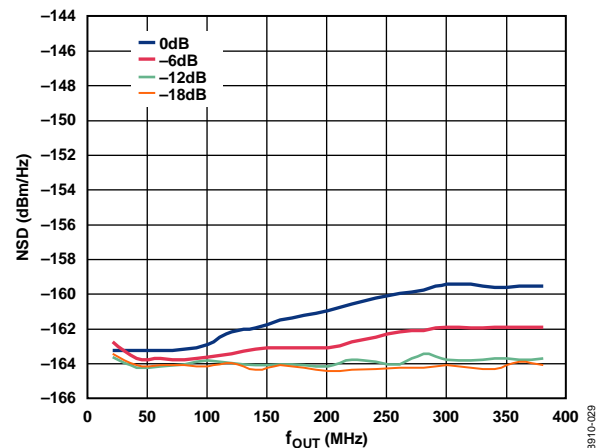

Figure 29. Eight-Tone NSD Performance vs.  $f_{OUT}$  over Digital Scale,  $4 \times f_{DATA} = 200$  MSPS, Full-Scale Current = 20 mA

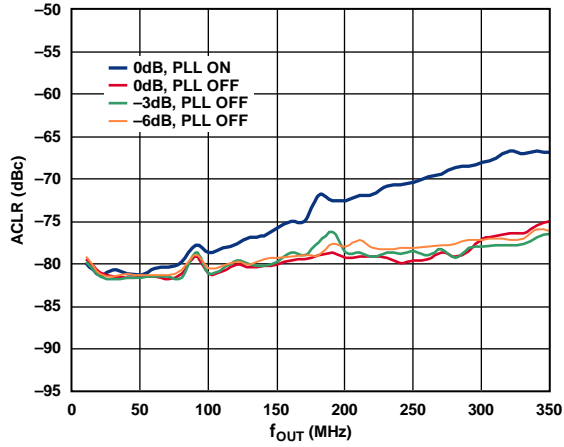

Figure 30. One-Carrier W-CDMA ACLR vs.  $f_{OUT}$ , Adjacent Channel, 4x Interpolation,  $f_{DATA} = 184.32$  MHz

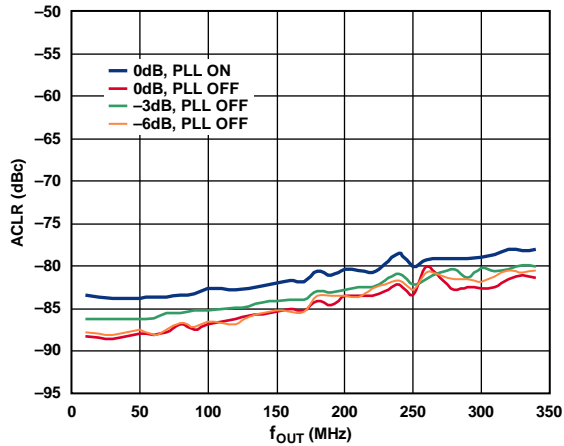

Figure 31. One-Carrier W-CDMA ACLR vs.  $f_{OUT}$ , Alternate Channel, 4x Interpolation,  $f_{DATA} = 184.32$  MHz

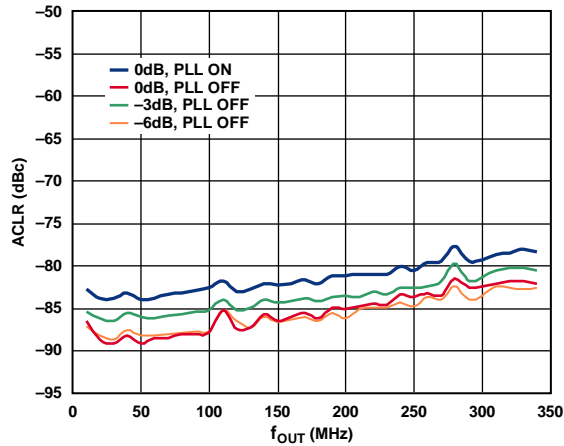
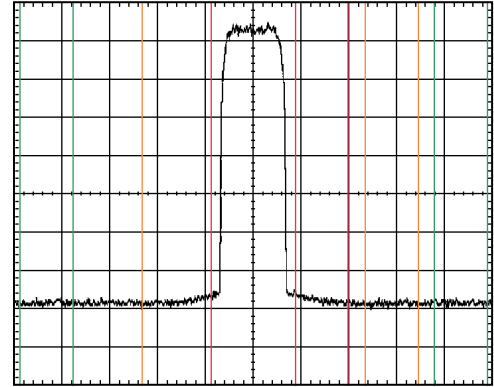

Figure 32. One-Carrier W-CDMA ACLR vs.  $f_{OUT}$ , Second Alternate Channel, 4x Interpolation,  $f_{DATA} = 184.32$  MHz



CENTER 150.00MHz SPAN 34.68MHz  
#RES BW 30kHz VBW 300kHz SWEEP 112.5ms (601 PTS)

RMS RESULTS	FREQ	OFFSET	REF BW	LOWER	UPPER
				dBc	dBm
CARRIER POWER	5.000MHz		3.840MHz	-78.88	-92.35
				-77.98	-91.45
				-82.65	-96.12
				-82.28	-95.75

Figure 33. One-Carrier W-CDMA ACLR,  $f_{OUT} = 150$  MHz, 4x Interpolation,  $f_{DATA} = 184.32$  MHz, PLL Off

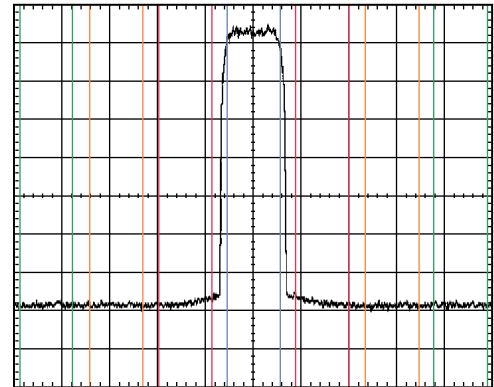

CENTER 150.00MHz SPAN 34.68MHz  
#RES BW 30kHz VBW 300kHz SWEEP 112.5ms (601 PTS)

RMS RESULTS	FREQ	OFFSET	REF BW	LOWER	UPPER
				dBc	dBm
CARRIER POWER	5.000MHz		3.840MHz	-74.50	-87.27
				-73.79	-86.56
				-82.99	-95.76
				-83.54	-96.31

Figure 34. One-Carrier W-CDMA ACLR,  $f_{OUT} = 150$  MHz, 4x Interpolation,  $f_{DATA} = 184.32$  MHz, PLL On

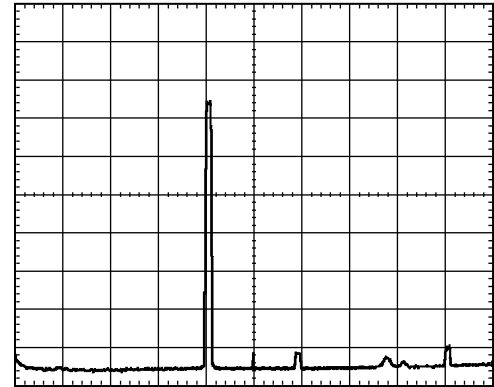

Figure 35. One-Carrier W-CDMA,  $f_{OUT} = 150$  MHz,  $f_{DAC} = 737.28$  MSPS, 4x Interpolation, -3 dBFS

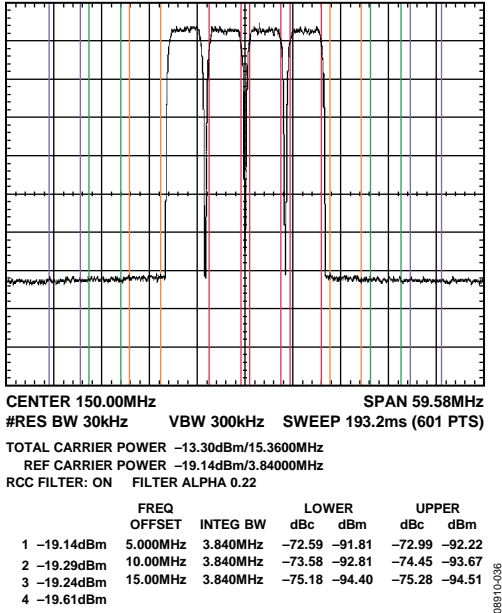

Figure 36. Four-Carrier W-CDMA,  $f_{OUT} = 150$  MHz,  $f_{DAC} = 737.28$  MSPS, 4x Interpolation, -3 dBFS, PLL Off

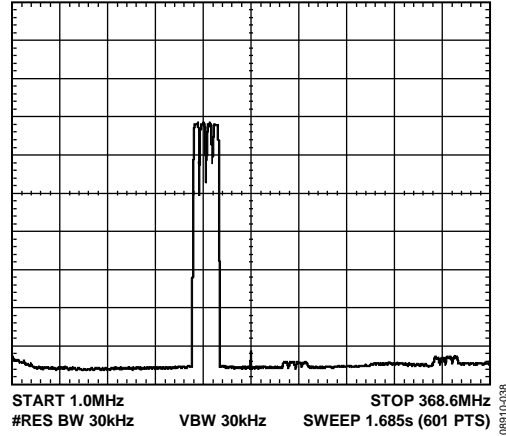

Figure 38. Four-Carrier W-CDMA,  $f_{OUT} = 150$  MHz,  $f_{DAC} = 737.28$  MSPS, 4x Interpolation, -3 dBFS

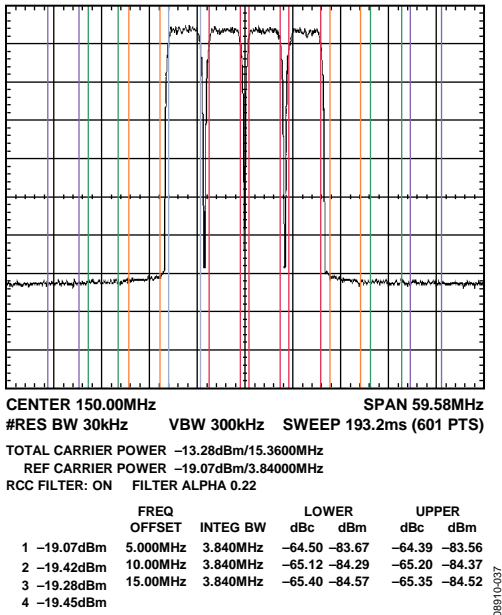

Figure 37. Four-Carrier W-CDMA,  $f_{OUT} = 150$  MHz,  $f_{DAC} = 737.28$  MSPS, 4x Interpolation, -3 dBFS, PLL On

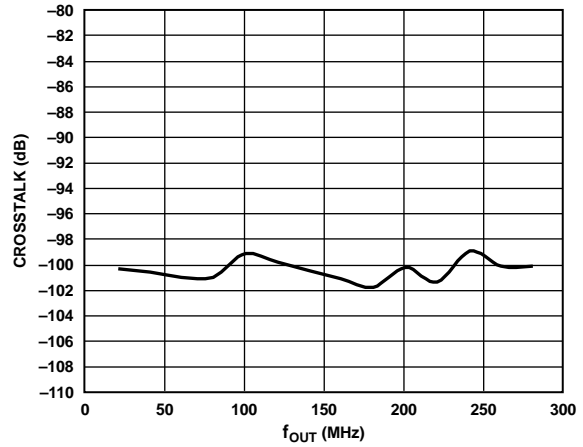

Figure 39. Crosstalk (DAC Set 1 to DAC Set 2), 4x Interpolation,  $f_{DATA} = 150$  MSPS, Digital Scale = 0 dBFS, Full-Scale Current = 20 mA

## TERMINOLOGY

### Integral Nonlinearity (INL)

INL is defined as the maximum deviation of the actual analog output from the ideal output, determined by a straight line drawn from zero scale to full scale.

### Differential Nonlinearity (DNL)

DNL is the measure of the variation in analog value, normalized to full scale, associated with a 1 LSB change in digital input code.

### Monotonicity

A DAC is monotonic if the output either increases or remains constant as the digital input increases.

### Offset Error

The deviation of the output current from the ideal of zero is called offset error. For IOUTx\_P, 0 mA output is expected when the inputs are all 0s. For IOUTx\_N, 0 mA output is expected when all inputs are set to 1.

### Gain Error

The difference between the actual and ideal output span. The actual span is determined by the difference between the output when all inputs are set to 1 and the output when all inputs are set to 0.

### Output Compliance Range

The range of allowable voltage at the output of a current-output DAC. Operation beyond the maximum compliance limits can cause either output stage saturation or breakdown, resulting in nonlinear performance.

### Temperature Drift

Temperature drift is specified as the maximum change from the ambient (25°C) value to the value at either  $T_{MIN}$  or  $T_{MAX}$ . For offset and gain drift, the drift is reported in ppm of full-scale range (FSR) per degrees Celsius. For reference drift, the drift is reported in ppm per degrees Celsius.

### Power Supply Rejection (PSR)

The maximum change in the full-scale output as the supplies are varied from minimum to maximum specified voltages.

### Settling Time

The time required for the output to reach and remain within a specified error band around its final value, measured from the start of the output transition.

### In-Band Spurious Free Dynamic Range (SFDR)

The difference, in decibels, between the peak amplitude of the output signal and the peak spurious signal between dc and the frequency equal to half the input data rate.

### Out-of-Band Spurious Free Dynamic Range (SFDR)

The difference, in decibels, between the peak amplitude of the output signal and the peak spurious signal within the band that starts at the frequency of the input data rate and ends at the Nyquist frequency of the DAC output sample rate. Normally, energy in this band is rejected by the interpolation filters. This specification, therefore, defines how well the interpolation filters work and the effect of other parasitic coupling paths on the DAC output.

### Total Harmonic Distortion (THD)

THD is the ratio of the rms sum of the first six harmonic components to the rms value of the measured fundamental. It is expressed as a percentage or in decibels.

### Signal-to-Noise Ratio (SNR)

SNR is the ratio of the rms value of the measured output signal to the rms sum of all other spectral components below the Nyquist frequency, excluding the first six harmonics and dc. The value for SNR is expressed in decibels.

### Interpolation Filter

An interpolation filter up-samples the input digital data by a multiple of  $f_{DATA}$  (interpolation rate) and then filters out the undesired spectral images created by the up-sampling process.

### Adjacent Channel Leakage Ratio (ACLR)

The ratio in dBc between the measured power within a channel relative to its adjacent channel.

### Complex Image Rejection

In a traditional two-part upconversion, two images are created around the second IF frequency. These images have the effect of wasting transmitter power and system bandwidth. By placing the real part of a second complex modulator in series with the first complex modulator, either the upper or lower frequency image near the second IF can be rejected.

## SERIAL PERIPHERAL INTERFACE

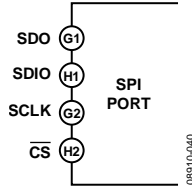

Figure 40. SPI Port

The serial port is a flexible, synchronous serial communications port allowing easy interface to many industry-standard micro-controllers and microprocessors. The serial I/O is compatible with most synchronous transfer formats, including both the Motorola SPI and Intel® SSR protocols. The interface allows read/write access to all registers that configure the AD9148. Single- or multiple-byte transfers are supported, as well as MSB-first or LSB-first transfer formats. The serial interface ports can be configured as a single pin I/O (SDIO) or two unidirectional pins for input/output (SDIO/SDO).

### GENERAL OPERATION OF THE SERIAL INTERFACE

There are two phases to a communication cycle with the AD9148. Phase 1 is the instruction cycle (the writing of an instruction byte into the device), coincident with the first eight SCLK rising edges. The instruction byte provides the serial port controller with information regarding the data transfer cycle, Phase 2 of the communication cycle. The Phase 1 instruction byte defines whether the upcoming data transfer is a read or a write, and the starting register address for the first byte of the data transfer. The first eight SCLK rising edges of each communication cycle are used to write the instruction byte into the device.

A logic high on the  $\overline{CS}$  pin followed by a logic low resets the SPI port timing to the initial state of the instruction cycle. From this state, the next eight rising SCLK edges represent the instruction bits of the current I/O operation, regardless of the state of the internal registers or the other signal levels at the inputs to the SPI port. If the SPI port is in an instruction cycle or a data transfer cycle, none of the present data is written.

The remaining SCLK edges are for Phase 2 of the communication cycle. Phase 2 is the actual data transfer between the device and the system controller. Phase 2 of the communication cycle is a transfer of one or more data bytes. Registers change immediately upon writing to the last bit of each transfer byte.

### DATA FORMAT

The instruction byte contains the information shown in Table 11.

Table 11. SPI Instruction Byte

I7 (MSB)	I6	I5	I4	I3	I2	I1	I0 (LSB)
R/W	A6	A5	A4	A3	A2	A1	A0

$\overline{R/W}$ , Bit 7 of the instruction byte, determines whether a read or a write data transfer occurs after the instruction byte write. Logic high indicates a read operation, and Logic 0 indicates a write operation.

A6 through A0, Bit 6 through Bit 0 of the instruction byte, determine the register that is accessed during the data transfer portion of the communication cycle. For multibyte transfers, this address is the starting byte address. The remaining register addresses are generated by the device based on the LSB-first bit (Register 0x00, Bit 6).

### SPI PIN DESCRIPTIONS

#### Serial Clock (SCLK)

The serial clock pin synchronizes data to and from the device and runs the internal state machines. The maximum frequency of SCLK is 40 MHz. All data input is registered on the rising edge of SCLK. All data is driven out on the falling edge of SCLK.

#### Chip Select ( $\overline{CS}$ )

Active low input starts and gates a communication cycle. It allows more than one device to be used on the same serial communications lines. The SDO and SDIO pins go to a high impedance state when this input is high. Chip select should stay low during the entire communication cycle.

#### Serial Data I/O (SDIO)

Data is always written into the device on this pin. However, this pin can be used as a bidirectional data line. The configuration of this pin is controlled by Register 0x00, Bit 7. The default is Logic 0, configuring the SDIO pin as unidirectional.

#### Serial Data Output (SDO)

Data is read from this pin for protocols that use separate lines for transmitting and receiving data. In the case where the device operates in a single bidirectional I/O mode, this pin does not output data and is set to a high impedance state.



## SPI REGISTER MAP

Table 12. Register Map

Addr	Register Name	Bit 7	Bit 6	Bit 5	Bit 4	Bit 3	Bit 2	Bit 1	Bit 0	Default
0x00	Comm	SDIO direction	LSB/MSB first	Software reset	DAC SPI select					0x00
0x01	Power control	Power-Down DAC Set 1	Power-Down DAC Set 2	Power-down data receiver						0x00
0x03	Data format	Binary format	Q first enable	Dual-port mode	Bus swap	Byte mode	Byte swap			0x20
0x04	Interrupt Enable 0	Enable PLL lock lost	Enable PLL lock	Enable sync lock lost	Enable sync lock		Enable FIFO SPI aligned	Enable FIFO Warning 1	Enable FIFO Warning 2	0x00
0x05	Interrupt Enable 1				Enable AED compare pass	Enable AED compare fail	Enable SED compare fail			0x00
0x06	Event Flag 0	PLL lock lost	PLL lock	Sync lock lost	Sync lock		FIFO SPI aligned	FIFO Warning 1	FIFO Warning 2	
0x07	Event Flag 1				AED compare pass	AED compare fail	SED compare fail			
0x08	Clock receiver control	CLK duty correction	REFCLK duty correction	CLK cross correction	REFCLK cross correction	0	1	1	1	0x37
0x0A	PLL Control 0	PLL enable	PLL manual enable	Manual VCO Band[5:0]						0x40
0x0C	PLL Control 1	PLL Loop Bandwidth[2:0]			0	1	0	0	1	0xF1
0x0D	PLL Control 2	N2[1:0]			PLL cross control enable	N0[1:0]		N1[1:0]		0xD9
0x0E	PLL Status 0					PLL Control Voltage[3:0]				
0x0F	PLL Status 1				VCO Band Readback[5:0]					
0x10	Sync Control 0	Sync enable	FIFO rate/data rate toggle			Rising edge sync	Sync Averaging[2:0]			0x08
0x11	Sync Control 1			Sync Phase Request[5:0]						0x00
0x12	Sync Status 0	Sync lost	Sync locked							
0x14	Data receiver control		One DCI							0x00
0x15	Data receiver status	LVDS rcvr frame high	LVDS rcvr frame low	LVDS rcvr DCI high	LVDS rcvr DCI low	LVDS rcvr Port B high	LVDS rcvr Port B low	LVDS rcvr Port A high	LVDS rcvr Port A low	
0x17	FIFO Status/Control Port A	FIFO Warning 1	FIFO Warning 2	FIFO reset aligned	FIFO SPI align ack	FIFO SPI align requesting	FIFO Phase Offset[2:0]			0x00
0x18	FIFO Status Port A	FIFO Level[7:0]								
0x19	FIFO Status/Control Port B	FIFO Warning 1	FIFO Warning 2	FIFO reset aligned	FIFO SPI align ack	FIFO SPI align requesting	FIFO Phase Offset[2:0]			0x00
0x1A	FIFO Status Port B	FIFO Level[7:0]								
0x1C	HB1 control	Enable pre mod	Bypass sinc <sup>-1</sup>				HB1[1:0]		Bypass HB1	0x40
0x1D	HB2 control						HB2[2:0]		Bypass HB2	0x00
0x1E	HB3 control	Bypass digital gain and phase adjustment					HB3[2:0]		Bypass HB3	0x81

Addr	Register Name	Bit 7	Bit 6	Bit 5	Bit 4	Bit 3	Bit 2	Bit 1	Bit 0	Default	
0x1F	Chip ID	Chip ID[7:0]									0x07
0x20 <sup>1</sup>	Coeff I Byte 0	0	Coeff_1i[3:0]				Coeff_0i[2:0]				0x00
0x21 <sup>1</sup>	Coeff I Byte 1	Coeff_3i[2:0]			Coeff_2i[4:0]						0xC0
0x22 <sup>1</sup>	Coeff I Byte 2	Coeff_4i[2:0]			0	Coeff_3i[6:3]				0xEF	
0x23 <sup>1</sup>	Coeff I Byte 3	0	Coeff_4i[9:3]								0x7F
0x24 <sup>1</sup>	Coeff Q Byte 0	0	Coeff_1q[3:0]				Coeff_0q[2:0]				0x69
0x25 <sup>1</sup>	Coeff Q Byte 1	Coeff_3q[2:0]			Coeff_2q[4:0]						0xE6
0x26 <sup>1</sup>	Coeff Q Byte 2	Coeff_4q[2:0]			0	Coeff_3q[6:3]				0x0D	
0x27 <sup>1</sup>	Coeff Q Byte 3	0	Coeff_4q[9:3]								0x00
0x28 <sup>1</sup>	I phase adj LSB	Phase Word I[7:0]									0x00
0x29 <sup>1</sup>	I phase adj MSB							Phase Word I[9:8]		0x00	
0x2A <sup>1</sup>	Q phase adj LSB	Phase Word Q[7:0]									0x00
0x2B <sup>1</sup>	Q phase adj MSB							Phase Word Q[9:8]		0x00	
0x2C <sup>1</sup>	I DC offset LSB	DC Offset I[7:0]									0x00
0x2D <sup>1</sup>	I DC offset MSB	DC Offset I[15:8]									0x00
0x2E <sup>1</sup>	Q DC offset LSB	DC Offset Q[7:0]									0x00
0x2F <sup>1</sup>	Q DC offset MSB	DC Offset Q[15:8]									0x00
0x30 <sup>1</sup>	IDAC FSC adj	IDAC FSC Adj[7:0]									0xF9
0x31 <sup>1</sup>	IDAC control	IDAC sleep						IDAC FSC Adj[9:8]		0x01	
0x32 <sup>1</sup>	AUX IDAC data	AUX IDAC Data[7:0]									0x00
0x33 <sup>1</sup>	AUX IDAC control	AUX IDAC sign	AUX IDAC current direction	AUX IDAC power-down				AUX IDAC Data[9:8]		0x00	
0x34 <sup>1</sup>	QDAC FSC adj	QDAC FSC Adj[7:0]									0xF9
0x35 <sup>1</sup>	QDAC control	QDAC sleep						QDAC FSC Adj[9:8]		0x01	
0x36 <sup>1</sup>	AUX QDAC data	AUX QDAC Data[7:0]									0x00
0x37 <sup>1</sup>	AUX QDAC control	AUX QDAC sign	AUX QDAC current direction	AUX QDAC power-down				AUX QDAC Data[9:8]		0x00	
0x38 <sup>1</sup>	SED_S0_L	SED Compare Pattern Sample0[7:0]									0xB6
0x39 <sup>1</sup>	SED_S0_H	SED Compare Pattern Sample0[15:8]									0x7A
0x3A <sup>1</sup>	SED_S1_L	SED Compare Pattern Sample1[7:0]									0x45
0x3B <sup>1</sup>	SED_S1_H	SED Compare Pattern Sample1[15:8]									0xEA
0x3C <sup>1</sup>	SED3_S2_L	SED Compare Pattern Sample2[7:0]									0x16
0x3D <sup>1</sup>	SED3_S2_H	SED Compare Pattern Sample2[15:8]									0x1A
0x3E <sup>1</sup>	SED4_S3_L	SED Compare Pattern Sample3[7:0]									0xC6
0x3F <sup>1</sup>	SED4_S3_H	SED Compare Pattern Sample3[15:8]									0xAA
0x40	SED control/status	SED compare enable	Port B error detected	Port A error detected		Auto-clear enable	Port B compare failed	Port A compare failed	Compare passed	0x00	
0x41 <sup>1</sup>	SED_R_L	SED Status Rising Edge Samples[7:0]									
0x42 <sup>1</sup>	SED_R_H	SED Status Rising Edge Samples[15:8]									
0x43 <sup>1</sup>	SED_F_L	SED Status Falling Edge Samples[7:0]									
0x44 <sup>1</sup>	SED_F_H	SED Status Falling Edge Samples[15:8]									
0x50 <sup>1</sup>	I gain control	I Gain[7:0]									0x40
0x51 <sup>1</sup>	Q gain control	Q Gain[7:0]									0x40

Addr	Register Name	Bit 7	Bit 6	Bit 5	Bit 4	Bit 3	Bit 2	Bit 1	Bit 0	Default	
0x54	FTW (LSB)	FTW[7:0]									0x00
0x55	FTW	FTW [15:8]									0x00
0x56	FTW	FTW[23:16]									0x00
0x57	FTW (MSB)	FTW[31:24]									0x00
0x58	Phase offset (MSB)	NCO Phase Offset[15:8]									0x00
0x59	Phase offset (LSB)	NCO Phase Offset[7:0]									0x00
0x5A	DDS/mod control	Bypass DDS/MOD		Frame NCO reset ack	Frame NCO reset request	FTW update ack	FTW update request		Sideband select	0x80	
0x5C	Die Temp Control 0							Latch temp data	Temp sensor power-down	0x01	
0x5D	Die Temp Control 1	0	0	0	0	1	0	1	0	0x20	
0x5E	Die temp LSB	Die Temp[7:0]									
0x5F	Die temp MSB	Die Temp[15:8]									
0x72	DCI delay								DCI Delay[1:0]	0x00	

<sup>1</sup> Register 0x20 to Register 0x3F and Register 0x41 to Register 0x51 configure DAC 1 (I) and DAC 2 (Q) data paths with DAC SPI select = 0 (Register 0x00[4]). Register 0x20 to Register 0x3F and Register 0x41 to Register 0x51 configure DAC 3 (I) and DAC 4 (Q) data paths with DAC SPI select = 1 (Register 0x00[4]).

## SPI REGISTER DESCRIPTIONS

Table 13. Register Descriptions

Register Name	Addr (Hex)	Bit	Name	Function	Default
Comm	00	7	SDIO	SDIO operation. 0 = SDIO operates as an input only. 1 = SDIO operates as bidirectional input/output.	0
		6	LSB/MSB first	SPI communication LSB first (default is MSB first). 0 = MSB first. 1 = LSB first.	0
		5	Software Reset	Software reset. Reset is asserted when this bit transitions from 0 to 1.	0
		4	DAC SPI select	Selects which DAC data path Register 0x20 to Register 0x3F and Register 0x41 to Register 0x51 configure. 0 = DAC 1 (I path) and DAC 2 (Q path) are configured. 1 = DAC 3 (I path) and DAC 4 (Q path) are configured.	0
Power Control	01	7	Power-Down DAC Set 1	Power down DAC 1 and power down DAC 2.	0
		6	Power-Down DAC Set 2	Power down DAC 3 and power down DAC 4.	0
		5	Power-down data receiver	Power down the input data receiver.	0

Register Name	Addr (Hex)	Bit	Name	Function	Default
Data Format	03	7	Binary format	Input data is in twos complement format (0) or unsigned binary format (1).	0
		6	Q first enable	Indicates I/Q data pairing on data input; I first (0), Q first (1).	0
		5	Dual-port mode	Number of input data ports used. Single port (0), dual port (1).	1
		4	Bus swap	0 = normal data input bus pin out (MSB to LSB). 1 = inverted data input bus pin out (LSB to MSB).	0
		3	Byte mode	0 = data input bus is 16-bit wide on each port. 1 = data input bus is two 8-bit wide buses on Port A.	0
		2	Byte swap	0 = normal data input bus pin out (MSB to LSB). 1 = inverted data input bus pin out (LSB to MSB).	0
Interrupt Enable 0	04	7	Enable PLL lock lost	Enables interrupt for PLL lock lost.	0
		6	Enable PLL lock	Enables interrupt for PLL lock.	0
		5	Enable sync lock lost	Enables interrupt for sync lock lost.	0
		4	Enable sync lock	Enables interrupt for sync lock.	0
		2	Enable FIFO SPI aligned	Enables interrupt for FIFO SPI aligned.	0
		1	Enable FIFO Warning 1	Enables interrupt for FIFO Warning 1.	0
		0	Enable FIFO Warning 2	Enables interrupt for FIFO Warning 2.	0
Interrupt Enable 1	05	4	Enable AED compare pass	Enables interrupt for AED compare pass.	0
		3	Enable AED compare fail	Enables interrupt for AED compare fail.	0
		2	Enable SED compare fail	Enables interrupt for SED compare fail.	0

Register Name	Addr (Hex)	Bit	Name	Function	Default
Event Flag 0 (All bits are high when interrupt is active. Clear interrupt by writing respective bit high.)	06	7	PLL lock lost	1 = indicates that the PLL that was previously locked has unlocked from the reference signal.	0
		6	PLL lock	1 = indicates that the PLL has locked to the reference clock input.	0
		5	Sync lock lost	1 = indicates that the sync logic that was previously locked has lost alignment.	0
		4	Sync lock	1 = indicates that the sync logic achieved sync alignment. This is indicated when no phase changes are requested for at least a few full averaging cycles.	0
		2	FIFO SPI aligned	1 = indicates that a FIFO reset originating from a serial port-based request has successfully completed.	0
		1	FIFO Warning 1	1 = indicates that the difference between the FIFO read and write pointers is 1.	0
		0	FIFO Warning 2	1 = indicates that the difference between the FIFO read and write pointers is 2.	0
Event Flag 1 (All bits are high when interrupt is active. Clear interrupt by writing respective bit high).	07	4	AED compare pass	1 = indicates that the SED logic detected a valid input data pattern comparison against the preprogrammed expected values.	0
		3	AED compare fail	1 = indicates that the SED logic detected an invalid input data pattern comparison against the preprogrammed expected values. This automatically clears when eight valid I/Q data pairs are received.	0
		2	SED compare fail	1 = indicates that the SED logic detected an invalid input data pattern comparison against the preprogrammed expected values.	0
Clock Receiver Control	08	7	CLK duty correction	Enables duty-cycle correction on CLK input.	0
		6	REFCLK duty correction	Enables duty-cycle correction on REFCLK input.	0
		5	CLK cross correction	Enables differential crossing correction on CLK input.	1
		4	REFCLK cross correction	Enables differential crossing correction on REFCLK input.	1
		3:0	0111	Always set these bits to 0111	0111
PLL Control 0	0A	7	PLL enable	Enables PLL clock multiplier.	0
		6	PLL manual enable	Enables PLL band selection mode (0 = auto, and 1 = manual).	1
		5:0	Manual VCO band	VCO band used in manual mode.	0
PLL Control 1	0C	7:5	PLL loop bandwidth	Selects PLL loop filter bandwidth. 000 = narrowest bandwidth. ... 111 = widest bandwidth.	110
		4:0	01001	Set these bits to 01001 for optimal PLL operation.	10001

Register Name	Addr (Hex)	Bit	Name	Function	Default
PLL Control 2	0D	7:6	N2	REFCLK-to-PLL controller clock rate ( $f_{PC\_CLK}$ ). 00 = 2. 01 = 4. 10 = 8. 11 = 16. $f_{PC\_CLK}$ must always be less than 50 MHz.	11
		4	PLL cross control enable	Enables PLL cross-point control.	
		3:2	N0	VCO-to-DACCLK divider. 00 = 1. 01 = 2. 10 = 4. 11 = 4.	001
		1:0	N1	DACCLK-to-REFCLK divider. 00 = 2. 01 = 4. 10 = 8. 11 = 16.	01
PLL Status 0	0E	3:0	PLL control voltage	PLL VCO control voltage readback value.	Read-only
PLL Status 1	0F	5:0	VCO band readback	VCO band value.	Read-only
Sync Control 0	10	7	Sync enable	Enables synchronization logic.	0
		6	FIFO rate/data rate toggle	Operates synchronization at the FIFO reset rate (0)/data rate (1).	0
		3	Rising edge sync	Rising edge of CLK samples sync input (1), falling edge of CLK samples sync input (0).	1
		2:0	Sync averaging	Average sync input of number of samples. 000 = 1. 001 = 2. 010 = 4. 011 = 8. 100 = 16. 101 = 32. 110 = 64. 111 = 128.	000

Register Name	Addr (Hex)	Bit	Name	Function	Default
Sync Control 1	11	5:0	Sync phase request	Offset of internal divided by 64 clock phase after sync. 000000 = 0 DAC clocks. ... 111111 = 63 DAC clocks.	000000
Sync Status 0	12	7	Sync Lost	Synchronization lost.	Read-only
		6	Sync locked	Synchronization found.	Read-only
Data Receiver Control	14	6	One DCI	0 = two DCIs used, DCIA_x and DCIB_x. 1 = one DCI used, DCIA_x.	0
Data Receiver Status	15	7	LVDS receiver frame high	Frame input LVDS level > 1.7 V.	Read-only
		6	LVDS receiver frame low	Frame input LVDS level < 0.7 V.	Read-only
		5	LVDS receiver DCI high	DCI input LVDS level > 1.7 V.	Read-only
		4	LVDS receiver DCI low	DCI input LVDS level < 0.7 V.	Read-only
		3	LVDS receiver Port B high	Port B input LVDS level > 1.7 V.	Read-only
		2	LVDS receiver Port B low	Port B input LVDS level < 0.7 V.	Read-only
		1	LVDS receiver Port A high	Port A input LVDS level > 1.7 V.	Read-only
		0	LVDS receiver Port A low	Port A input LVDS level < 0.7 V.	Read-only
FIFO Status/ Control Port A	17	7	FIFO Warning 1	FIFO read and write pointers within $\pm 1$ .	Read-only
		6	FIFO Warning 2	FIFO read and write pointers within $\pm 2$	Read-only
		5	FIFO reset aligned	FIFO read and write pointers aligned after chip reset.	Read-only
		4	FIFO SPI align acknowledge	FIFO read and write pointers aligned after SPI driven FIFO reset.	Read-only
		3	FIFO SPI align requesting	Request FIFO read and write pointers alignment via SPI.	0
		2:0	FIFO phase offset	FIFO read and write pointer phase offset from optimal phase following FIFO reset. 000 = 0 offset from optimal phase. ... 111 = 7 offset from optimal phase. The optimal value is 0.	000

Register Name	Addr (Hex)	Bit	Name	Function	Default
FIFO Status Port A	18	7:0	FIFO Level	Thermometer encoded measure of the FIFO level.	Read-only
FIFO Status/ Control Port B	19	7	FIFO Warning 1	FIFO read and write pointers within $\pm 1$ .	Read-only
		6	FIFO Warning 2	FIFO read and write pointers within $\pm 2$ .	Read-only
		5	FIFO reset aligned	FIFO read and write pointers aligned after chip reset.	Read-only
		4	FIFO SPI align acknowledge	FIFO read and write pointers aligned after SPI driven FIFO reset.	Read-only
		3	FIFO SPI align requesting	Request FIFO read and write pointers alignment via SPI.	0
	2:0	FIFO phase offset	FIFO read and write pointer phase offset from optimal phase following FIFO reset.  000 = 0 offset from optimal phase.  ...  111 = 7 offset from optimal phase.  The optimal value is 0.	000	
FIFO Status Port B	1A	7:0	FIFO level	Thermometer encoded measure of the FIFO level.	Read-only
HB1 Control	1C	7	Enable pre mod	Enable $f_S/2$ modulation stage that precedes Stage 1 interpolation filter.	0
		6	Bypass sinc-1	Sinc-1 filter bypass.	1
		2:1	HB1[1:0]	Modulation mode for first stage interpolation filter ( $f_{HB1} = 2 \times f_{IN1}$ ).  00 = input signal modulated by dc. Filter pass band is from $-0.2$ to $+0.2$ of $f_{HB1}$ .  01 = input signal modulated by dc. Filter pass band is from $0.05$ to $0.45$ of $f_{HB1}$ .  10 = input signal modulated by $f_{HB1}/2$ . Filter pass band is from $0.3$ to $0.7$ of $f_{HB1}$ .  11 = input signal modulated by $f_{HB1}/2$ . Filter pass band is from $0.55$ to $0.95$ of $f_{HB1}$ .	00
		0	Bypass HB1	First stage interpolation filter bypass.	0

Register Name	Addr (Hex)	Bit	Name	Function	Default
HB2 Control	1D		HB2[2:0]	<p>Modulation mode for second stage interpolation filter (<math>f_{HB2} = 2 \times f_{IN2}</math>).</p> <p>000 = input signal modulated by dc. Filter pass band is from <math>-0.1</math> to <math>+0.1</math> of <math>f_{HB2}</math>.</p> <p>001 = input signal modulated by dc. Filter pass band is from <math>0.025</math> to <math>0.225</math> of <math>f_{HB2}</math>.</p> <p>010 = input signal modulated by <math>f_{HB2}/4</math>. Filter pass band is from <math>0.15</math> to <math>0.35</math> of <math>f_{HB2}</math>.</p> <p>011 = input signal modulated by <math>f_{HB2}/4</math>. Filter pass band is from <math>0.275</math> to <math>0.475</math> of <math>f_{HB2}</math>.</p> <p>100 = input signal modulated by <math>f_{HB2}/2</math>. Filter pass band is from <math>0.4</math> to <math>0.6</math> of <math>f_{HB2}</math>.</p> <p>101 = input signal modulated by <math>f_{HB2}/2</math>. Filter pass band is from <math>0.525</math> to <math>0.725</math> of <math>f_{HB2}</math>.</p> <p>110 = input signal modulated by <math>3 f_{HB2}/4</math>. Filter pass band is from <math>0.65</math> to <math>0.85</math> of <math>f_{HB2}</math>.</p> <p>111 = input signal modulated by <math>3 f_{HB2}/4</math>. Filter pass band is from <math>0.775</math> to <math>0.975</math> of <math>f_{HB2}</math>.</p>	000
		0	Bypass HB2	Second stage interpolation filter bypass.	0
HB3 Control	1E	7	Bypass digital gain and phase adjustment	1 = bypass digital gain and phase compensation.	1
		3:1	HB3[2:0]	<p>Modulation mode for third stage interpolation filter (<math>f_{HB3} = 2 \times f_{IN3}</math>).</p> <p>000 = input signal modulated by dc. Filter pass band is from <math>-0.1</math> to <math>+0.1</math> of <math>f_{HB3}</math>.</p> <p>001 = input signal modulated by dc. Filter pass band is from <math>0.025</math> to <math>0.225</math> of <math>f_{HB3}</math>.</p> <p>010 = input signal modulated by <math>f_{HB3}/4</math>. Filter pass band is from <math>0.15</math> to <math>0.35</math> of <math>f_{HB3}</math>.</p> <p>011 = input signal modulated by <math>f_{HB3}/4</math>. Filter pass band is from <math>0.275</math> to <math>0.475</math> of <math>f_{HB3}</math>.</p> <p>100 = input signal modulated by <math>f_{HB3}/2</math>. Filter pass band is from <math>0.4</math> to <math>0.6</math> of <math>f_{HB3}</math>.</p> <p>101: Input signal modulated by <math>f_{HB3}/2</math>. Filter pass band is from <math>0.525</math> to <math>0.725</math> of <math>f_{HB3}</math>.</p> <p>110 = input signal modulated by <math>3 f_{HB3}/4</math>. Filter pass band is from <math>0.65</math> to <math>0.85</math> of <math>f_{HB3}</math>.</p> <p>111 = input signal modulated by <math>3 f_{HB3}/4</math>. Filter pass band is from <math>0.775</math> to <math>0.975</math> of <math>f_{HB3}</math>.</p>	000
		0	Bypass HB3	Third stage interpolation filter bypass.	1
Chip ID	1F	7:0	Chip ID	Chip ID readback.	07

Register Name	Addr (Hex)	Bit	Name	Function	Default
Coeff I Byte 0	20	7	0	Set this bit to 0.	0
		6:3	Coeff_1i[3:0]	I-Path DAC Sinc <sup>-1</sup> Filter Coefficient 2 in twos complement format.	0
		2:0	Coeff_0i	I-Path DAC Sinc <sup>-1</sup> Filter Coefficient 1 in twos complement format. Set DAC SPI select = 0 to configure DAC 1 path. Set DAC SPI select = 1 to configure DAC 3 path.	0
Coeff I Byte 1	21	7:5	Coeff_3i[2:0]	I-Path DAC Sinc <sup>-1</sup> Filter Coefficient 4 (LSB) in twos complement format.	6
		4:0	Coeff_2i	I-Path DAC Sinc <sup>-1</sup> Filter Coefficient 3 in twos complement format. Set DAC SPI select = 0 to configure DAC 1 path. Set DAC SPI select = 1 to configure DAC 3 path.	0
Coeff I Byte 2	22	7:5	Coeff_4i[2:0]	I-Path DAC Sinc <sup>-1</sup> Filter Coefficient 5 (LSB) in twos complement format.	7
		4	0	Set this bit to 0.	0
		3:0	Coeff_3i[6:3]	Set I-Path DAC Sinc <sup>-1</sup> Filter Coefficient 4 (MSB) in twos complement format. DAC SPI select = 0 to configure DAC 1 path. Set DAC SPI select = 1 to configure DAC 3 path.	F
Coeff I Byte 3	23	7	0	Set this bit to 0.	0
		6:0	Coeff_4i[9:3]	I-Path DAC Sinc <sup>-1</sup> Filter Coefficient 5 (MSB) in twos complement format. Set DAC SPI select = 0 to configure DAC 1 path. Set DAC SPI select = 1 to configure DAC 3 path.	7F
Coeff Q Byte 0	24	7	0	Set this bit to 0.	0
		6:3	Coeff_1q[3:0]	Q-Path DAC Sinc <sup>-1</sup> Filter Coefficient 2 in twos complement format.	D
		2:0	Coeff_0q	Q-Path DAC Sinc <sup>-1</sup> Filter Coefficient 1 in twos complement format. Set DAC SPI select = 0 to configure DAC 2 path. Set DAC SPI select = 1 to configure DAC 4 path.	1
Coeff Q Byte 1	25	7:5	Coeff_3q[2:0]	Q-Path DAC Sinc <sup>-1</sup> Filter Coefficient 4 (LSB) in twos complement format.	7
		4:0	Coeff_2q	Q-Path DAC Sinc <sup>-1</sup> Filter Coefficient 3 in twos complement format. Set DAC SPI select = 0 to configure DAC 2 path. Set DAC SPI select = 1 to configure DAC 4 path.	6

Register Name	Addr (Hex)	Bit	Name	Function	Default
Coeff Q Byte 2	26	7:5	Coeff_4q[2:0]	Q-Path DAC Sinc <sup>-1</sup> Filter Coefficient 5 (LSB) in twos complement format.	0
		4	0	Set this bit to 0.	0
		3:0	Coeff_3q[6:3]	Q-Path DAC Sinc <sup>-1</sup> Filter Coefficient 4 (MSB) in twos complement format.  Set DAC SPI select = 0 to configure DAC 2 path. Set DAC SPI select = 1 to configure DAC 4 path.	D
Coeff Q Byte 3	27	7	0	Set this bit to 0.	0
		6:0	Coeff_4q[9:3]	Q-Path DAC Sinc <sup>-1</sup> Filter Coefficient 5 (MSB) in twos complement format.  Set DAC SPI select = 0 to configure DAC 2 path. Set DAC SPI select = 1 to configure DAC 4 path.	0
I Phase Adj LSB	28	7:0	Phase Word I[7:0]	See Register 0x29.	0
I Phase Adj MSB	29	1:0	Phase Word I[9:8]	Phase Word I[9:0] is used to insert a phase offset between the I and Q data paths. The adjustment range is $\pm 1.75^\circ$ .  Set DAC SPI select = 0 to configure DAC 1 path. Set DAC SPI select = 1 to configure DAC 3 path.	0
Q Phase Adj LSB	2A	7:0	Phase Word Q[7:0]	See Register 0x2B.	0
Q Phase Adj MSB	2B	1:0	Phase Word Q[9:8]	Phase Word Q[9:0] is used to insert a phase offset between the I and Q data paths. The adjustment range is $\pm 1.75^\circ$ .  Set DAC SPI select = 0 to configure DAC 2 path. Set DAC SPI select = 1 to configure DAC 4 path.	0
I DC Offset LSB	2C	7:0	DC Offset I[7:0]	See Register 0x2D.	0
I DC Offset MSB	2D	7:0	DC Offset I[15:8]	DC Offset I[15:0] is a value added directly to the samples written to the IDAC. The LSB bit weight is $2^0$ . The adjustment range is $\pm 10$ mA.  Set DAC SPI select = 0 to configure DAC 1 path. Set DAC SPI select = 1 to configure DAC 3 path.	0
Q DC Offset LSB	2E	7:0	DC Offset Q[7:0]	See Register 0x2F.	0
Q DC Offset MSB	2F	7:0	DC Offset Q[15:8]	DC Offset Q[15:0] is a value added directly to the samples written to the QDAC. The LSB bit weight is $2^0$ . The adjustment range is $\pm 10$ mA.  Set DAC SPI select = 0 to configure DAC 2 path. Set DAC SPI select = 1 to configure DAC 4 path.	0 0

Register Name	Addr (Hex)	Bit	Name	Function	Default
IDAC FSC Adj	30	7:0	IDAC FSC Adj	IDAC full-scale current adjustment (LSB part). IDAC FS Adj[9:0] sets the full-scale current of the IDAC. The full-scale current can be adjusted from 8.64 mA to 31.6 mA in step sizes of approximately 22.5 $\mu$ A.  0x000 = 8.64 mA.  ...  0x200 = 20.14 mA.  ...  0x3FF = 31.66 mA.  Set DAC SPI select = 0 to configure DAC 1 path. Set DAC SPI select = 1 to configure DAC 3 path.	F9
IDAC Control	31	7	IDAC sleep	IDAC sleep mode (fast wake-up mode).	0
		1:0	IDAC FSC Adj[9:8]	IDAC full-scale current adjustment (MSB part)  Set DAC SPI select = 0 to configure DAC 1 path. Set DAC SPI select = 1 to configure DAC 3 path.	01
Aux IDAC Data	32	7:0	AUX IDAC Data	Auxiliary IDAC data (LSB part). AUX IDAC Data[9:0] sets the magnitude of the aux DAC current. The range is 0 mA to 2 mA, and the step size is 2 $\mu$ A.  0x000 = 0.000 mA.  0x001 = 0x002 mA.  ...  0x3FF = 2.046 mA.  Set DAC SPI select = 0 to configure DAC 1 path. Set DAC SPI select = 1 to configure DAC 3 path.	00
Aux IDAC Control	33	7	AUX IDAC sign	Auxiliary IDAC output sign.  0 = positive, current is directed to the AUXx_P pin. 1 = negative, current is directed to the AUXx_N pin.	0
		6	AUX IDAC current direction	Auxiliary IDAC current direction.  0 = source. 1 = sink.	0
		5	AUX IDAC power-down	Auxiliary IDAC power-down.	0
		1:0	AUX IDAC Data[9:8]	Auxiliary IDAC data (MSB part).  Set DAC SPI select = 0 to configure DAC 1 path. Set DAC SPI select = 1 to configure DAC 3 path.	00

Register Name	Addr (Hex)	Bit	Name	Function	Default
QDAC FSC Adj	34	7:0	QDAC FSC Adj	Q DAC full-scale current adjustment (LSB part). QDAC FS Adj[9:0] sets the full-scale current of the QDAC. The full-scale current can be adjusted from 8.64 mA to 31.6 mA in step sizes of approximately 22.5 $\mu$ A.  0x000 = 8.64 mA ... 0x200 = 20.14mA ... 0x3FF = 31.66 mA  Set DAC SPI select = 0 to configure DAC 2 path. Set DAC SPI select = 1 to configure DAC 4 path.	F9
QDAC Control	35	7	QDAC sleep	Q DAC sleep mode (fast wake-up mode).	0
		1:0	QDAC FSC Adj[9:8]	QDAC full-scale current adjustment (MSB part).  Set DAC SPI select = 0 to configure DAC 2 path. Set DAC SPI select = 1 to configure DAC 4 path.	01
Aux QDAC Data	36	7:0	AUX QDAC Data	Auxiliary QDAC data (LSB part). AUX QDAC Data[9:0] sets the magnitude of the AUX DAC current. The range is 0 mA to 2 mA, and the step size is 2 $\mu$ A.  0x000 = 0.000 mA. 0x001 = 0x002 mA. ... 0x3FF = 2.046 mA.  Set DAC SPI select = 0 to configure DAC 2 path. Set DAC SPI select = 1 to configure DAC 4 path.	00
Aux QDAC Control	37	7	AUX QDAC sign	Auxiliary QDAC output sign.  0 = positive, current is directed to the AUXx_P pin. 1 = negative, current is directed to the AUXx_N pin.	0
		6	AUX QDAC current direction	Auxiliary QDAC current direction.  0 = source. 1 = sink.	0
		5	AUX QDAC power-down	Auxiliary QDAC power-down.	0
		1:0	AUX QDAC Data[9:8]	Auxiliary QDAC data (MSB part).  Set DAC SPI select = 0 to configure DAC 2 path. Set DAC SPI select = 1 to configure DAC 4 path.	00

Register Name	Addr (Hex)	Bit	Name	Function	Default
SED_S0_L	38	7:0	SED Compare Pattern Sample0[7:0]	Compare Pattern Sample0[15:0] is the word that is compared with Data Sample 0 captured at the input interface by the rising edge of DCI.  Set DAC SPI select = 0 to configure Port A. Set DAC SPI select = 1 to configure Port B.	
SED_S0_H	39	7:0	SED Compare Pattern Sample0[15:8]	Compare Pattern Sample0[15:0] is the word that is compared with Data Sample 0 captured at the input interface by the rising edge of DCI.  Set DAC SPI select = 0 to configure Port A. Set DAC SPI select = 1 to configure Port B.	
SED_S1_L	3A	7:0	SED Compare Pattern Sample1[7:0]	Compare Pattern Sample1[15:0] is the word that is compared with Data Sample 1 captured at the input interface by the falling edge of DCI.  Set DAC SPI select = 0 to configure Port A. Set DAC SPI select = 1 to configure Port B.	
SED_S1_H	3B	7:0	SED Compare Pattern Sample1[15:8]	Compare Pattern Sample1[15:0] is the word that is compared with Data Sample 1 captured at the input interface by the falling edge of DCI.  Set DAC SPI select = 0 to configure Port A. Set DAC SPI select = 1 to configure Port B.	
SED_S2_L	3C	7:0	SED Compare Pattern Sample2[7:0]	Compare Pattern Sample2[15:0] is the word that is compared with Data Sample 2 captured at the input interface by the rising edge of DCI.  Set DAC SPI select = 0 to configure Port A. Set DAC SPI select = 1 to configure Port B.	
SED_S2_H	3D	7:0	SED Compare Pattern Sample2[15:8]	Compare Pattern Sample2[15:0] is the word that is compared with Data Sample 2 captured at the input interface by the rising edge of DCI.  Set DAC SPI select = 0 to configure Port A. Set DAC SPI select = 1 to configure Port B.	
SED_S3_L	3E	7:0	SED Compare Pattern Sample3 [7:0]	Compare Pattern Sample3[15:0] is the word that is compared with Data Sample 3 captured at the input interface by the falling edge of DCI.  Set DAC SPI select = 0 to configure Port A. Set DAC SPI select = 1 to configure Port B.	
SED_S3_H	3F	7:0	SED Compare Pattern Sample3[15:8]	Compare Pattern Sample3[15:0] is the word that is compared with Data Sample 3 captured at the input interface by the falling edge of DCI.  Set DAC SPI select = 0 to configure Port A. Set DAC SPI select = 1 to configure Port B.	

Register Name	Addr (Hex)	Bit	Name	Function	Default
SED Control/Status	40	7	SED compare enable	Enables the SED circuitry.	0
		6	Port B error detected	Status of last compare on Port B.	0
		5	Port A error detected	Status of last compare on Port A.	0
		3	Auto-clear enable	Enables the auto reset after eight valid sample sets.	0
		2	Port B compare failed	Fail status determined for last sample set on Port B.	0
		1	Port A compare failed	Fail status determined for last sample set on Port A.	0
		0	Compare passed	Pass status determined for last sample set.	0
SED_R_L	41	7:0	SED Status Rising Edge Samples[7:0]	SED Status Rising Edge Samples[15:0] indicate which bits were received in error.  Set DAC SPI select = 0 to read back errors on Port A. Set DAC SPI select = 1 to read back errors on Port B.	Read-only
SED_R_H	42	7:0	SED Status Rising Edge Samples[15:8]	SED Status Rising Edge Samples[15:0] indicate which bits were received in error.  Set DAC SPI select = 0 to read back errors on Port A. Set DAC SPI select = 1 to read back errors on Port B.	Read-only
SED_F_L	43	7:0	SED Status Falling Edge Samples[7:0]	SED Status Falling Edge Samples[15:0] indicate which bits were received in error.  Set DAC SPI select = 0 to read back errors on Port A. Set DAC SPI select = 1 to read back errors on Port B.	Read-only
SED_F_H	44	7:0	SED Status Falling Edge Samples[15:8]	SED Status Falling Edge Samples[15:0] indicate which bits were received in error.  Set DAC SPI select = 0 to read back errors on Port A. Set DAC SPI select = 1 to read back errors on Port B.	Read-only
I Gain Control	50	7:0	IGain	IGain[7:0] is a value that directly scales the samples written to the IDAC. The bit weighting is MSB = $2^1$ and LSB = $2^{-6}$ , which yields a multiplier range of 0 to 3.984375.  Set DAC SPI select = 0 to configure DAC 1 path. Set DAC SPI select = 1 to configure DAC 3 path.	40
Q Gain Control	51	7:0	QGain	QGain[7:0] is a value that directly scales the samples written to the QDAC. The bit weighting is MSB = $2^1$ and LSB = $2^{-6}$ , which yields a multiplier range of 0 to 3.984375.  Set DAC SPI select = 0 to configure DAC 2 path. Set DAC SPI select = 1 to configure DAC 4 path.	40

Register Name	Addr (Hex)	Bit	Name	Function	Default
FTW (LSB)	54	7:0	FTW[7:0]	See Register 0x57.	0
FTW	55	7:0	FTW[15:8]	See Register 0x57.	0
FTW	56	7:0	FTW [23:16]	See Register 0x57.	0
FTW (MSB)	57	7:0	FTW [31:24]	FTW[31:0] is the 32-bit frequency tuning word that determines the frequency of the complex carrier generated by the on-chip NCO. The frequency is not updated when the FTW registers are written. The values are only updated when Register 0x5A[2] transitions from 0 to 1.	0
Phase Offset MSB	58	7:0	NCO Phase Offset[15:8]	See Register 0x59.	0
Phase Offset LSB	59	7:0	NCO Phase Offset[7:0]	NCO Phase Offset[15:0] sets the phase of the complex carrier signal when the NCO is reset. The phase offset spans between 0° and 360°. Each bit represents an offset of 0.0055°. Value is in twos complement format.	0
DDS/Mod Control	5A	7	Bypass DDS/MOD	1 = bypass NCO.	1
		5	Frame NCO reset ack	1 = indicates that the NCO has been reset due to an extended FRAME <sub>x</sub> pulse signal.	0
		4	Frame NCO reset request	0→1 = The NCO is reset on the first extended FRAME <sub>x</sub> pulse after this bit transitions from 0 to 1.	0
		3	FTW update ack	1 = indicates that the FTW has been updated with the SPI value.	0
		2	FTW update request	0→1 = FTW is updated with the SPI value on a 0-to-1 transition of this bit.	0
		0	Sideband select	0 = The modulator output high-side image. 1 = The modulator output low-side image. The image is spectrally inverted compared to the input data.	0
Die Temp Control 0	5C	1	Latch temp data	0 → 1 = latches temp sensor data. This should be completed before the Die Temp[15:0] is readback.	0
		0	Temp sensor power-down	1 = powers down the aux ADC that converts die temperature.	1
Die Temp Control 1	5D	7:0	00001010	Set these bits to 00001010 for optimal temperature sensor operation.	100000
Die Temp (LSBs)	5E	7:0	Die Temp[7:0]	Die Temp[15:0] indicates the approximate die temperature.	Read-only
Die Temp (MSBs)	5F	7:0	Die Temp[15:8]	Die Temp[15:0] indicates the approximate die temperature.	Read-only
DCI Delay	72	1:0	DCI delay	Programmable delay added DCI. 00 = no added delay. 01 = 200 ps delay. 10 = 400 ps delay. 11 = 600 ps delay.	00

## INPUT DATA PORTS

The AD9148 can operate in three data input modes: dual-port mode, single-port mode, and byte mode. In dual-port mode, DAC 1 and DAC 2 receive data from Port A, and DAC 3 and DAC 4 receive data from Port B. In single-port mode, all four DACs receive data from Port A. In byte mode, all four DACs receive data from Port A, but the port is split into two 8-bit wide buses. In all modes, the data input timing is relative to a DCI signal provided with the data.

### DUAL-PORT MODE

In dual-port mode, the DCI signal indicates to which DAC the data is intended. On the rising edge of DCI, data is latched into DAC 1 and DAC 3. On the falling edge of DCI, data is latched into DAC 2 and DAC 4. This pattern repeats continuously.

There is a SPI programmable option (Register 0x14[6]) to provide one DCI for both input ports or two DCIs, where each DCI is associated with one input port. Two DCIs are useful when the data for each port is coming from a different data source. These cases are illustrated in Figure 45 and Figure 46.

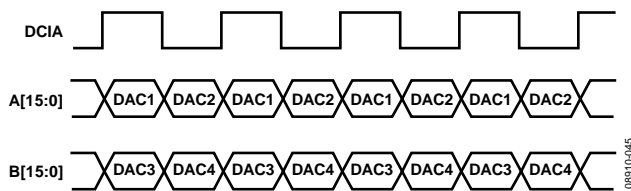

Figure 45. Timing Diagram for Dual-Port Mode, One DCI

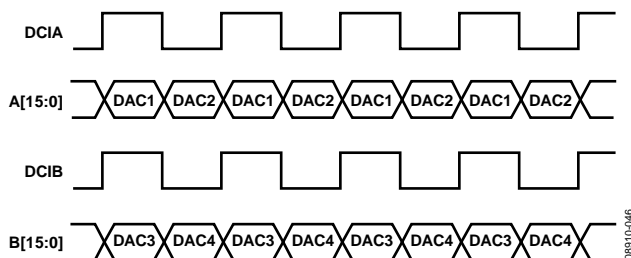

Figure 46. Timing Diagram for Dual-Port Mode, Two DCI

Each data sample, by default, is expected to be formatted as an MSB sent to Bit 15 and an LSB sent to Bit 0 for each port. The AD9148 contains an option to swap the bus (Register 0x03[4]). When this bus swap bit is set, the MSB should be sent to Bit 0, and the LSB should be sent to Bit 15 for each port.

### SINGLE-PORT MODE

In single-port mode, a FRAME signal must be provided along with the DCI signal and the data. The FRAME signal indicates to which DAC the data is intended. When FRAME goes high, the first data-word goes to DAC 1, and the second data-word goes to DAC 2. When FRAME goes low, the first data-word goes to DAC 3, and the second data-word goes to DAC 4. This pattern repeats continuously as illustrated in Figure 47.

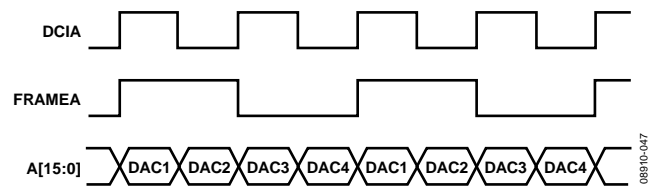

Figure 47. Timing Diagram for Single-Port Mode

Each data sample, by default, is expected to be formatted as an MSB sent to Bit 15 and an LSB sent to Bit 0. When the bus swap bit is set (Register 0x03[4]), the MSB should be sent to Bit 0, and the LSB should be sent to Bit 15 for each port.

The FRAME signal is sampled with the same internal signal as the data and has the same set-up and hold timing relative to DCI. If desired, only the first FRAME pulse needs to be generated. This initializes the internal clock phases inside the device, and data latches just as if the periodic FRAME signal were sent.

**BYTE MODE**

In byte mode, a FRAME signal must be provided along with the DCI signal and the data. The most significant byte of the data should correspond with DCI being high, and the least significant byte of the data should correspond with DCI being low. The FRAME signal indicates to which DAC the data is intended. When FRAME is high, data on the top half of the port (A[15:8]) is sent to DAC 1 and data on the bottom half of the port (A[7:0]) is sent to DAC 3. When the FRAME is low, data on the top half of the port is sent to DAC 2 and data on the bottom half of the port is sent to DAC 4. This pattern repeats continuously as shown in Figure 48.

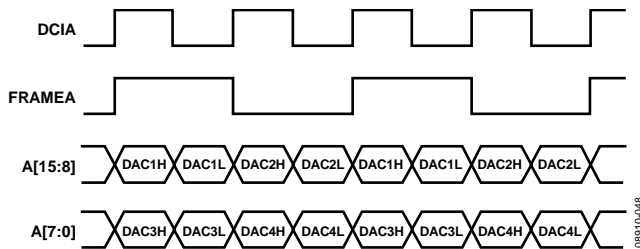

Figure 48. Timing Diagram for Byte Mode

The AD9148 also includes a byte swap feature. By default, the bytes should be formatted as an MSB sent to Bit 15 on Bus 1 and Bit 7 on Bus 2. When byte swap is enabled (Register 0x03[2]), an MSB should be sent to Bit 8 on Bus 1 and Bit 0 on Bus 2. This is described in Table 14.

Table 14. Byte Swap Formatting

Byte Swap	Byte	A[15:8]	A[7:0]
0	MSB	Data Set 1[15:8]	Data Set 2[15:8]
0	LSB	Data Set 1[7:0]	Data Set 2[7:0]
1	MSB	Data Set 1[8:15]	Data Set 2[8:15]
1	LSB	Data Set 1[0:7]	Data Set 2[0:7]

**DATA INTERFACE OPTIONS**

To enable optimization of the data interface, some additional options have been provided in the following registers:

- Data format (Register 0x03)
- Data receiver control (Register 0x14)
- Data receiver status (Register 0x15)

Depending on the data rate and DCI vs. data skew, the internal DCI can be inverted to meet the valid data timing window.

**RECOMMENDED FRAME INPUT BIAS CIRCUITRY**

Because the frame signal can be used as a reference clock in the byte mode or as a trigger to reset the FIFO, it is recommended that the frame input be tied to LVDS logic low when it is not used (that is, when it is not driven by an ASIC or FPGA). The external bias circuit shown in Figure 49 is recommended for this purpose. This bias circuit applies to both FRAMEA and FRAMEB ports.

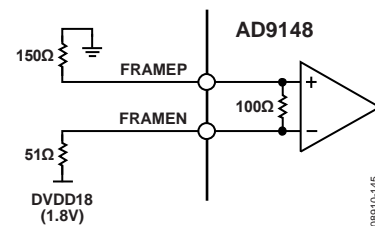

Figure 49. External Bias Circuit

## FIFO OPERATION

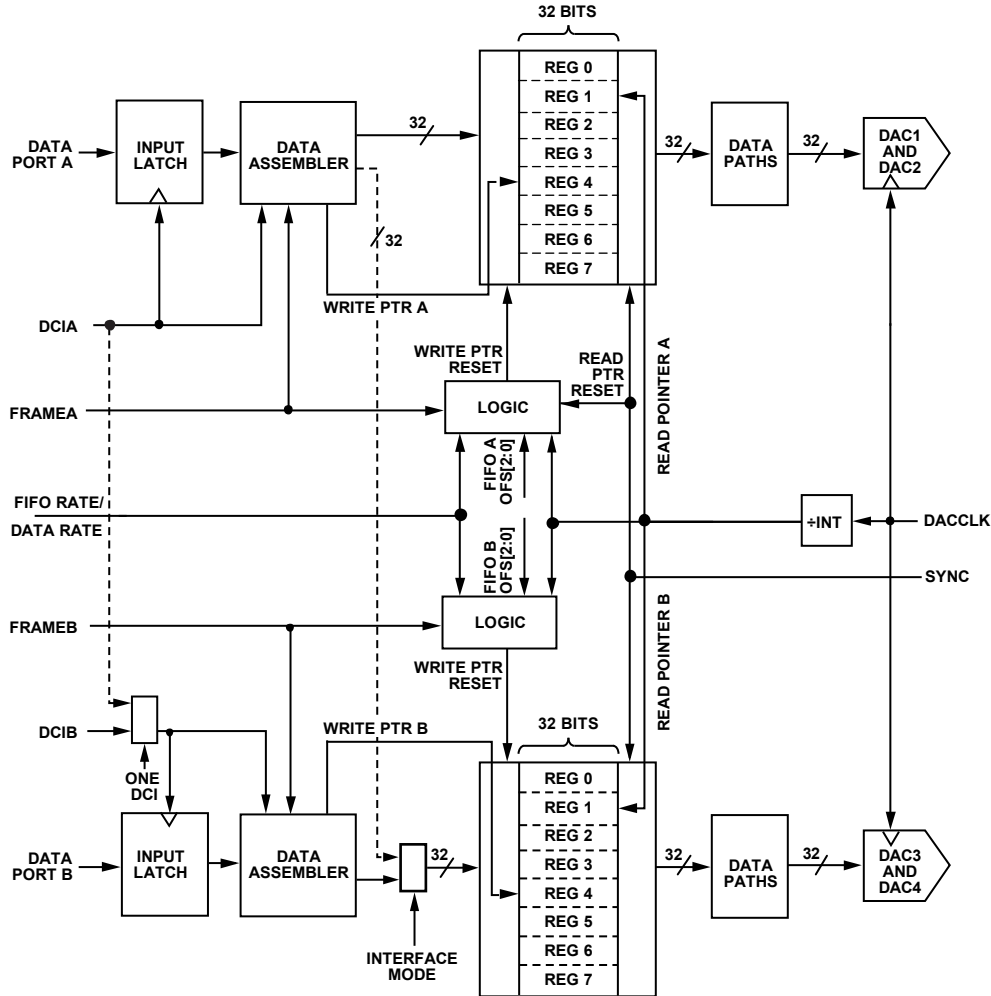

Figure 50. Block Diagram of FIFO

The AD9148 contains two 32-bit wide, 8-word deep FIFOs (one per dual DAC) designed to relax the timing relationship between the data arriving at the DAC input ports and the internal DAC data rate clock. The FIFOs can also be used to provide an adjustable pipeline delay between the DCIx clocks and the DACCLK allowing realignment of data input in a multichip system. This significantly increases the timing budget of the interface.

Figure 50 shows the block diagram of the datapath through the FIFO. The data is latched into the device, is formatted, and is then written into the FIFO register determined by the FIFO write pointer. The value of the write pointer is incremented every time a new word is loaded into the FIFO. Meanwhile, data is read from the FIFO register determined by the read pointer and fed into the digital datapath. The value of the read pointer is updated every time data is read into the datapath from the FIFO. This happens at the data rate, that is, the DACCLK rate divided by the interpolation ratio. The difference between the write and read pointers represents the FIFO pipeline delay and is

important to take into account when understanding the overall pipeline delay of the AD9148.

In single-port and byte interface modes, the incoming digital data is sampled at twice the data rate (DCIA). The data is then assembled based on the interface mode. At the output of the data assembler block, the data samples for DAC 1 and DAC 2 are written to FIFO A and the data samples for DAC 3 and DAC 4 are written to FIFO B at the data rate.

Valid data is transmitted through the FIFO as long as the FIFO does not overflow or become empty. An overflow or empty condition of the FIFO is the same as the write pointer and the read pointer being equal. When both pointers are equal, an attempt is made to read and write a single FIFO register simultaneously. This simultaneous register access leads to unreliable data transfer through the FIFO and must be avoided.

Nominally, data is written to the FIFO at the same rate as data is read from the FIFO. This keeps the data level in the FIFO constant. If data is written to the FIFO faster than data is read, the data level in the FIFO increases. If the data is written to the device slower than data is read, the data level in the FIFO decreases. For a maximum timing margin, the FIFO level should be maintained near half full, which is the same as maintaining a difference of 4 between the write pointer and read pointer values.

**SYNCHRONIZING AND RESETTING THE FIFO**

To avoid any concurrent reads and writes to the same FIFO address and to assure a fixed pipeline delay, it is important to reset the state of the FIFO pointers to known states. The pipeline delay in the AD9148 comes from two sources, FIFO delay and the delay though the signal processing in the DAC.

To assure a fixed and predictable pipeline delay in the signal processing, the FIFO read operation is synchronized with the DACCLK and, more importantly, in case of interpolation, its divided down version so that the same edge of the slowest clock in the signal processing reads the same data in the FIFO. The synchronization is performed by resetting the FIFO read pointer to a known state relative to the slowest clock used in the signal processing. This synchronization is enabled by setting Bit 7 in Register 0x10 to 1, and it uses the REFCLK/SYNC signal for its reference.

To manage the FIFO pipeline delay, the FIFO write pointer must be synchronized with the read pointer to avoid concurrent access to the FIFO and to potentially compensate for any data input phase mismatch. This synchronization can be performed either at the data rate (see the Data Rate Synchronization section) or at the FIFO rate (see the FIFO Rate Synchronization section).

**FIFO Synchronization Modes**

To benefit from the advantages of the FIFO functionality in the different modes of operations, PLL on/off, standalone, or multi-chip synchronization, the FIFO can operate in the following ways:

- Synchronization at the data rate
- Synchronization at the FIFO rate (data rate/FIFO depth)
- No synchronization

As discussed in the Input Data Ports section, in single-port mode and byte mode, the FRAME input is used as a data select signal that indicates to which DAC the input data is intended to be written. When synchronization is needed, the FRAME signal is given another function, initializing the FIFO write pointer address. When the FRAME signal is asserted high for at least the time interval needed to load complete data to the four DACs (which correspond to one DCI period in dual-port mode and two DCI periods in single-port mode or byte mode), the FIFO write pointer is reset to a value dependent on the synchronization mode selected and the FIFO phase offset bits of the corresponding FIFO Status/Control Port x register, Register 0x17 or Register 0x19.

**Data Rate Synchronization**

In this mode, the REFCLK/SYNC signal is used to reset the FIFO read pointer to 0. The edge of the CLK used to sample the SYNC signal is selected by Bit 3 of Register 0x10. If the PLL is used, REFCLK is used as a SYNC signal, and the FIFO read pointer is reset at the REFCLK rate divided by 64. The data rate synchronization is selected by setting Bit 6 of Register 0x10 to 0.

As previously mentioned, the FRAME signal is used to reset the FIFO write pointer. When the FRAME is asserted, the FIFO write pointer is reset to the address defined in Bits[2:0] of the corresponding FIFO Status/Control Port x register (Register 0x17 or Register 0x19) the next time the read pointer becomes 0 (see Figure 51).

The data rate synchronization, the write pointer of the FIFO, and the read pointer of the FIFO are synchronized at the SYNC rate and have a fixed phase offset.

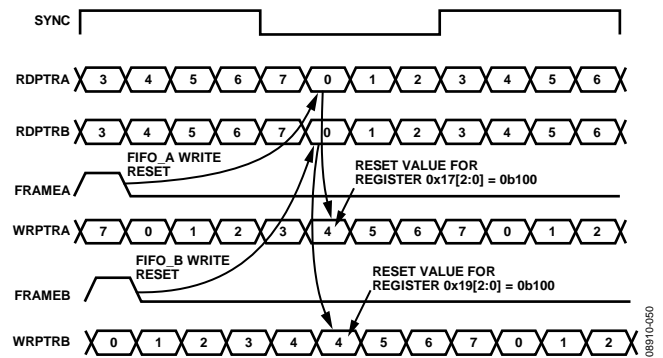

Figure 51. Timing of the FRAME Input vs. Write Pointer Value in Data Rate Synchronization

**FIFO Rate Synchronization**

In this mode, the REFCLK/SYNC signal is used to reset the FIFO read pointer to 0. The edge of the CLK\_x used to sample the SYNC signal is selected by Bit 3 of Register 0x10. As previously mentioned, the FRAME signal is used to reset the FIFO write pointer. In the FIFO rate synchronization mode, the FIFO write pointer is reset immediately after the FRAME signal is asserted high for at least the time interval needed to load complete data to the four DACs, and the FIFO write pointer is reset to the address defined in Bits[2:0] of the corresponding FIFO Status/Control Port x register, Register 0x17 or Register 0x19 (see Figure 52).

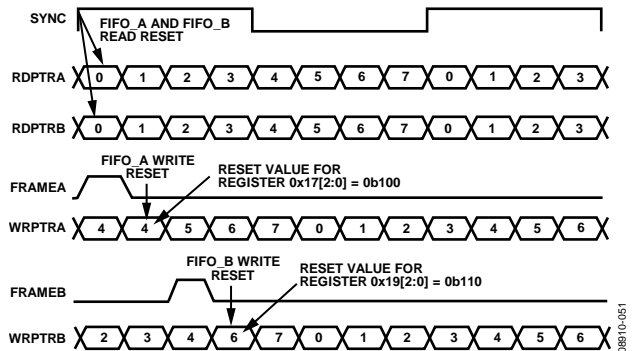

Figure 52. Timing of the FRAME Input vs. Write Pointer Value in FIFO Rate Synchronization

### No Synchronization

In this mode, Bit 7 in Register 0x10 is set to 0, the pipeline delay in the signal processing is not controlled, and the read pointer of the FIFO is never reset. However, to assure that the FIFO can operate safely and there is no concurrent access to FIFO from the write and read pointer to the same address, it is important to ensure that the phase offset between the two pointers is greater than 2. In consequence, the only FIFO reset that can be used safely is the data rate synchronization, Bit 6 of Register 0x10 set to 0, where the FIFO is reset with a fixed offset of 4 between the write and read pointers. Because there is no SYNC signal, the reset of the FIFO write pointer can only be done by a FRAME signal or an SPI command.

### FIFO Reset Commands

Depending on the configuration of the system, the FIFO reset can be done manually or periodically for a multichip system. The AD9148 provides two ways to resetting the FIFO pointers: SPI interface or periodic reset using the FRAME signal.

The SPI also gives access to each FIFO phase offset in Bits [2:0] of the corresponding FIFO status/control registers, Register 0x17 and Register 0x19. The value in these three bits corresponds either to the offset between the write and read pointer in the data rate synchronization or to the absolute address of the FIFO write pointer in the FIFO rate synchronization.

### SPI Command for Manual Reset

If a manual reset is acceptable, the FIFO pointer addresses can be reset using the SPI interface.

To initialize the FIFO data level through the SPI, Bit 3 of Register 0x17 (FIFO Port A) or Bit 3 of Register 0x19 (FIFO Port B) should be toggled from 0 to 1 and back. When the write to the register is complete, the corresponding FIFO data level is initialized.

The recommended procedure for a SPI FIFO data level initialization is

1. Request FIFO Port A or FIFO Port B level reset by setting Bit 3 in Register 0x17 or Bit 3 in Register 0x19 to Logic 1. The FIFO phase offset, Bits [2:0] in Register 0x17 or Bits [2:0] in Register 0x19, should also be written at the same time to set the desired value of offset between the FIFO write and read pointers.
2. Verify that the part acknowledges the request by ensuring that Bit 4 in Register 0x17 or Bit 4 in Register 0x19 is set to Logic 1.

3. Remove the request by resetting Bit 3, Register 0x17 or Bit 3, Register 0x19 to 0.
4. The FIFO SPI aligned flag in the Event Flag 0 register, Bit 2 in Register 0x06, is set when the reset of the write pointer has been realized. Bit 4 in Register 0x17 or Bit 4 in Register 0x19 is reset to 0 to indicate which FIFO has generated this flag.

Note that the SPI writes to Register 0x17 or Register 0x19 should be done while maintaining a constant value in the FIFO phase offset bits.

### FIFO Reset Using FRAME Signal

The FIFO pointers can also be reset using the FRAME signals. If only one DCI is used, only the FRAMEA signal is used for the FIFO reset. This mode is enabled by setting Bit 6 in Register 0x10.

As discussed in the FIFO Synchronization Modes section, the FRAME input is used to initialize the FIFO data level value. When the FRAME signal is asserted high for at least the time interval needed to load the complete data to the four DACs, the write pointer is reset depending on the mode of synchronization chosen.

- Data rate synchronization (default), Bit 6 of Register 0x10, is set to 0. When read pointer reaches 0, write pointer reset to FIFO offset phase.
- FIFO rate synchronization, Bit 6 of Register 0x10, is set to 1. On the rising edge of the FRAME signal, write pointer reset to FIFO start level.

### MONITORING THE FIFO STATUS

The FIFO initialization and status can be read from Register 0x17. This register provides information about the FIFO initialization method and whether the initialization was successful. The MSB of Register 0x17 is a FIFO warning flag that can optionally trigger a device  $\overline{\text{IRQ}}$ . This flag is an indication that the FIFO is close to emptying (FIFO level is 1) or overflowing (FIFO level is 7). This is an indication that the data may soon be corrupted, and action should be taken.

The FIFO data level can be read from Register 0x18 at any time. The SPI reported FIFO data level is denoted as a 7-bit thermometer code of the write counter state relative to the absolute read counter being 0. The optimum FIFO data level of four is, therefore, reported as a value of 00001111 in the status register.

Note that, depending on the timing relationship between DCI and the main DACCLK, the FIFO level value can be off by a  $\pm 1$  count. Therefore, it is important to keep the difference between the read and write points to at least 2.

## DEVICE SYNCHRONIZATION

### SYNCHRONIZING MULTIPLE DEVICES

System demands may require that the outputs of multiple DACs be synchronized with each other or with a system clock. Systems that support transmit diversity or beam-forming, where multiple antennas are used to transmit a correlated signal, require multiple DAC outputs to be phase aligned with each other. Systems with a time-division multiplexing transmit chain may require one or more DACs to be synchronized with a system-level reference clock.

Multiple devices are considered synchronized to each other when the state of the clock generation state machines is identical for all parts and time aligned data is being read from the FIFOs of all parts simultaneously. Devices are considered synchronized to a system clock when there is a fixed and known relationship between the clock generation state machine and the data being read from the FIFO and a particular clock edge of the system clock. The AD9148 has provisions for enabling multiple devices to be synchronized to each other or to a system clock.

The AD9148 supports synchronization in two different modes, data rate mode and FIFO rate mode. The two modes are distinguished by the lowest rate clock that the synchronization logic attempts to synchronize. In data rate mode, the input data rate represents the lowest synchronized clock. In FIFO rate mode, the FIFO rate, which is the data rate divided by the FIFO depth of 8, represents the lowest rate clock. The advantage of the FIFO

rate synchronization is increased setup and hold times of DCI relative to the CLK input. When in data rate synchronization mode, the elasticity of the FIFO is not used to absorb timing variations between the data source and DAC, resulting in tighter setup and hold time requirements.

The method chosen for providing the DAC sampling clock directly impacts the synchronization methods available. When the device clock multiplier is used, only data rate synchronization is available. When the DAC sampling clock is sourced directly, both data rate mode and FIFO rate mode synchronization are available.

### SYNCHRONIZATION WITH CLOCK MULTIPLICATION

When using the clock multiplier to generate the DACCLK, the REFCLK/SYNC input signal acts as both the reference clock for the PLL-based clock multiplier and as the synchronization signal. To synchronize devices, the REFCLK/SYNC signal must be distributed with low skew to all of the devices to be synchronized. Skew between the REFCLK/SYNC signals of different devices show up directly as a timing mismatch at the DAC outputs.

The frequency of the REFCLK/SYNC signal is typically equal to the input data rate. The FRAME signal and DCI signals can be created in the FPGA along with the data. A circuit diagram of a typical configuration is shown in Figure 53.

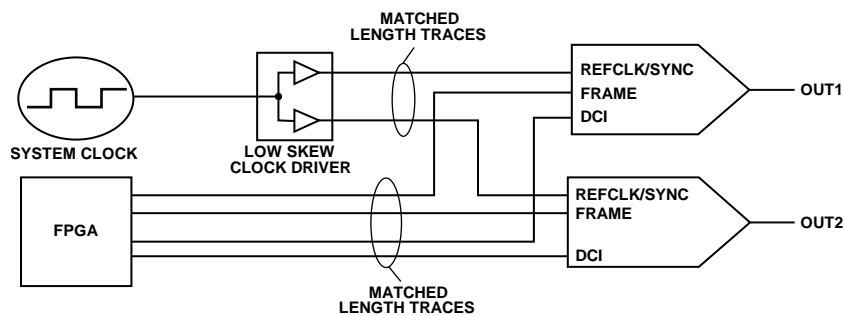

Figure 53. Typical Circuit Diagram for Synchronizing Devices with Clock Multiplication Enabled

The following procedure outlines the steps required to synchronize multiple devices. The procedure assumes that the REFCLK/SYNC signal is applied to all of the devices and the PLL of each device is phase locked to it. Each individual device must follow this procedure.

The procedure for synchronization when using the PLL follows:

1. Configure for data rate, periodic synchronization by writing 0xC0 to the sync control register (Register 0x10).
2. Read the sync status register (Register 0x12) and verify that the sync locked bit (Bit 6) is set high indicating that the device achieved back-end synchronization and that the sync lost bit (Bit 7) is low. These levels indicate that the clocks are running with a constant and known phase relative to the sync signal.
3. Reset the FIFO by strobing the FRAME signal high for at least the time interval needed to load complete data to the four DACs. Resetting the FIFO ensures that the correct data is being read from the FIFO. This completes the synchronization procedure, and at this stage, all devices should be synchronized.

To maintain synchronization, the skew between REFCLK/SYNC signals of the devices must be less than  $t_{\text{SKEW}}$  nanoseconds. There is also a setup and hold time to be observed between the DCI and data of each device and the REFCLK/SYNC signal. When resetting the FIFO, the FRAME signal must be held high for at least the time interval needed to load complete data to the four DACs (one DCI period for dual-port mode and two DCI periods for single-port or byte mode). A timing diagram of the input signals is shown in Figure 54.

The example in Figure 54 shows a REFCLK/SYNC frequency equal to the data rate. Whereas this is the most common situation, it is not strictly required for proper synchronization. Any REFCLK/SYNC frequency that satisfies the following equations is acceptable:

$$f_{\text{SYNC}} = f_{\text{DACCLK}}/2^N \text{ and } f_{\text{SYNC}} \leq f_{\text{DATA}}$$

where  $N = 1, 2, 3, \text{ or } 4$ .

For example, a configuration with  $4\times$  interpolation and clock frequencies of  $f_{\text{VCO}} = 1600 \text{ MHz}$ ,  $f_{\text{DACCLK}} = 800 \text{ MHz}$ , and  $f_{\text{DATA}} = 200 \text{ MHz}$ ,  $f_{\text{SYNC}} = 100 \text{ MHz}$  would be a viable solution.

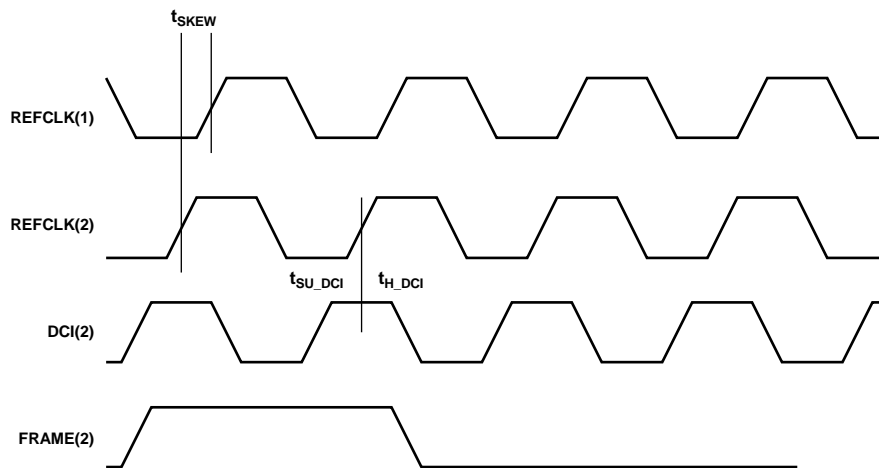

Figure 54. Timing Diagram Required for Synchronizing Two Devices

09810-0653

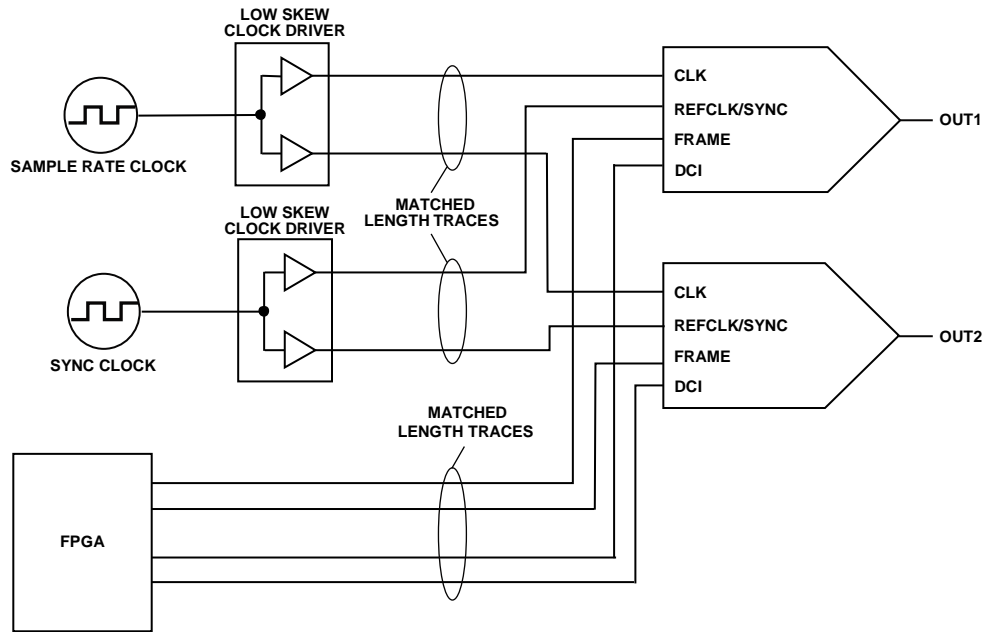

Figure 55. Typical Circuit Diagram for Synchronizing Devices to a System Clock

08910-054

### SYNCHRONIZATION WITH DIRECT CLOCKING

When directly sourcing the DAC sample rate clock to CLK, a separate REFCLK/SYNC input signal is required for synchronization. To synchronize devices, the CLK signals and the REFCLK/SYNC signals must be distributed with low skew to all of the devices being synchronized. This configuration is shown below in Figure 55.

#### Data Rate Mode Synchronization

The following procedure outlines the steps required to synchronize multiple devices in data rate mode. The procedure assumes that the CLK and REFCLK/SYNC signals are applied to all of the devices. Each individual device must follow the procedure.

The procedure for data rate synchronization when directly sourcing the DAC sampling clock follows:

1. Configure for data rate, periodic synchronization by writing 0xC0 to the sync control register (Register 0x10). Additional synchronization options are available (see the Additional Synchronization Features section).
2. Poll the sync locked bit (Bit 6, Register 0x12) to verify that the device is back-end synchronized. A high level on this bit indicates that the clocks are running with a constant and known phase relative to the sync signal.
3. Reset the FIFO by strobing the FRAME signal for at least the time interval needed to load complete data to the four DACs. Resetting the FIFO ensures that the correct data is being read from the FIFO of each of the devices simultaneously. This completes the synchronization procedure, and at this stage, all devices should be synchronized.

To ensure that each of the DACs are updated with the correct data on the same DACCLK edge, two timing relationships must be met on each DAC. DCI (and data) must meet the setup and hold times with respect to the rising edge of CLK, and REFCLK/SYNC

must also meet the setup and hold time with respect to the rising edge of CLK. When resetting the FIFO, the FRAME signal must be held high for at least the time interval needed to load complete data to the four DACs (one DCI period for dual-port mode and two DCI periods for single-port or byte mode). When these conditions are met, the outputs of the DACs will be updated within  $t_{SKEW} + t_{OUTDLY}$  nanoseconds of each other. A timing diagram that illustrates the timing requirements of the input signals is shown in Figure 56.

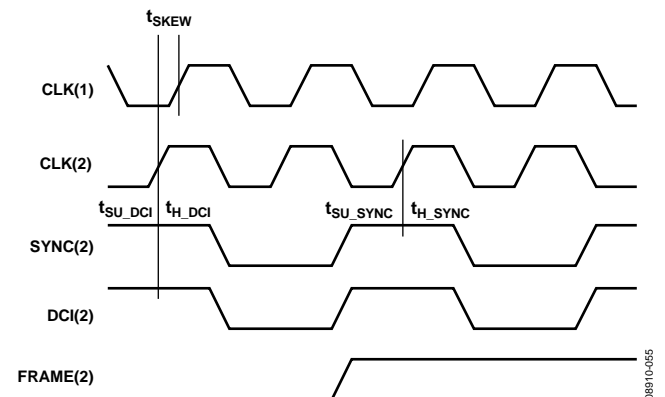

Figure 56. Synchronization Signal Timing Requirements in Data Rate Mode, 2x Interpolation

08910-055

Figure 56 shows the synchronization signal timing with 2x interpolation, so that  $f_{DCI} = \frac{1}{2} \times f_{CLK}$ . The REFCLK/SYNC input is shown equal to the DCI rate. The maximum frequency at which the device can be resynchronized in data rate mode can be expressed as

$$f_{SYNC} = \frac{f_{DATA}}{2^N}$$

for any positive integer, N.

Generally, for values of N equal to or greater than 3, the FIFO rate synchronization mode is chosen.

### FIFO Rate Mode Synchronization

The following procedure outlines the steps required to synchronize multiple devices in FIFO rate mode. The procedure assumes that the CLK and REFCLK/SYNC signals are applied to all of the devices. Each individual device must follow the procedure.

The procedure for FIFO rate synchronization when directly sourcing the DAC sampling clock follows:

1. Configure for FIFO rate, periodic synchronization by writing 0x80 to the sync control register (Register 0x10). Additional synchronization options are available and are described in the Additional Synchronization Features section.
2. Poll the sync locked bit (Bit 6, Register 0x12) to verify that the device is back-end synchronized. A high level on this bit indicates that the clocks are running with a constant and known phase relative to the sync signal.
3. Reset the FIFO by strobing the FRAME signal high for at least the time interval needed to load complete data to the four DACs. Resetting the FIFO ensures that the correct data is being read from the FIFO of each of the devices simultaneously. This completes the synchronization procedure, and at this stage, all devices should be synchronized.

To ensure that each of the DACs is updated with the correct data on the same DACCLK edge, two timing relationships must be met on each DAC. DCI (and data) must meet the setup and hold times with respect to the rising edge of CLK, and REFCLK/SYNC must also meet the setup and hold time with respect to the rising edge of CLK. When resetting the FIFO, the FRAME signal must be held high for at least the time interval needed to load complete data to the four DACs (one DCI period for dual-port mode, and two DCI periods for single-port or byte mode). When these conditions are met, the outputs of the DACs will be updated within  $t_{\text{SKEW}} + t_{\text{OUTDLY}}$  nanoseconds of each other. A timing diagram that illustrates the timing requirements of the input signals is shown in Figure 57.

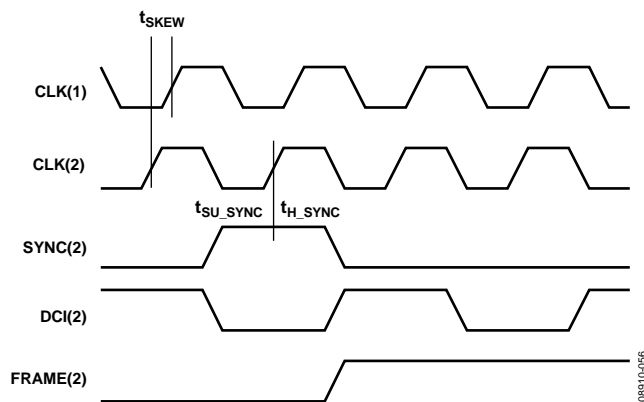

Figure 57. Synchronization Signal Timing Requirements in FIFO Rate Mode, 2x Interpolation

Figure 57 shows the synchronization signal timing with 2x interpolation, so that  $f_{\text{DCI}} = \frac{1}{2} \times f_{\text{CLK}}$ . The REFCLK/SYNC input is shown equal to the FIFO rate. The maximum frequency at which the device can be resynchronized in FIFO rate mode can be expressed as

$$f_{\text{SYNC}} = \frac{f_{\text{DATA}}}{8 \times 2^N}$$

for any positive integer, N.

### ADDITIONAL SYNCHRONIZATION FEATURES

The synchronization logic incorporates additional features that provide means for querying the status of the synchronization and for improving the robustness of the synchronization. For more information on these features, see the Sync Status Bits section and the Timing Optimization section.

#### Sync Status Bits

When the sync locked bit (Bit 6, Register 0x12) is set, it indicates that the synchronization logic has reached alignment. This is determined when the clock generation state machine phase is constant. This takes between  $(11 + \text{Averaging}) \times 64$  and  $(11 + \text{Averaging}) \times 128$  DACCLK cycles. This bit may optionally trigger an IRQ, as described in the Interrupt Request Operation section.

When the sync lost bit (Bit 7, Register 0x12) is set, it indicates that a previously synchronized device has lost alignment. This bit is latched and remains set until cleared by overwriting the register. This bit may optionally trigger an IRQ as described in the Interrupt Request Operation section.

#### Timing Optimization

The REFCLK/SYNC signal is sampled by a version of the DACCLK. If sampling errors are detected, the opposite sampling edge can be selected to improve the sampling point. The sampling edge can be selected by setting Bit 3, Register 0x10 (1 = rising and 0 = falling).

The synchronization logic resynchronizes when a phase change between the REFCLK/SYNC signal and the state of the clock generation state machine exceeds a threshold. To mitigate the effects of jitter and prevent erroneous resynchronizations, the relative phase can be averaged. The amount of averaging is set by the sync averaging bits (Bits[2:0], Register 0x10) and can be set from 1 to 128. The higher the number of averages, the more slowly the device recognizes and resynchronizes to a legitimate phase correction. Generally, the averaging should be made as large as possible while still meeting the allotted resynchronization time interval.

Additional information on synchronization can be found in the [AN-1093 Application Note, Synchronization of Multiple AD9122 TxDAC+ Converters](#).

Table 15. Synchronization Setup and Hold Times

Parameter	Min	Max	Unit
$t_{\text{SKEW}}$	$-t_{\text{DACCLK}}/2$	$+t_{\text{DACCLK}}/2$	ps
$t_{\text{SU\_SYNC}}$	-100		ps
$t_{\text{H\_SYNC}}$	+400		ps

## INTERFACE TIMING

The timing diagram for the digital interface port is shown in Figure 59. The sampling point of the data bus nominally occurs 250 ps after each edge of the DCI signal and has an uncertainty of  $\pm 250$  ps when the DCI delay is set to 00b (Register 0x72[1:0]), as illustrated by the sampling interval. The data and FRAME signals must be valid throughout this sampling interval. The data and FRAME signals may change at any time between sampling intervals.

The setup ( $t_s$ ) and hold ( $t_H$ ) times with respect to the edges are shown in Figure 59. The minimum setup and hold times are shown in Table 16.

**Table 16. Data Port Setup and Hold Times**

DCI Delay (Register 0x72, Bits[1:0])	Minimum Setup Time, $t_s$ (ns)	Minimum Hold Time, $t_H$ (ns)
00	-0.02	0.52
01	-0.16	0.78
10	-0.28	1.03
11	-0.36	1.16

The data interface timing can be verified by using the SED circuitry. See the Interface Timing Validation section for details.

In data rate mode with synchronization enabled, a second timing constraint between DCI and DACCLK must be met in addition to the DCI-to-data timing shown in Table 17. In data rate mode, only one FIFO slot is being used. The DCI to DACCLK timing restriction is required to prevent data being written to and read from the FIFO slot at the same time. The required timing between DCI and DACCLK is shown in Figure 58.

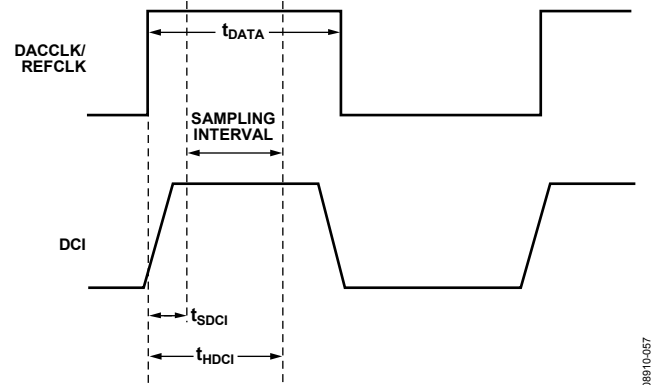

Figure 58. Timing Diagram for Input Data Port (Data Rate Mode with Sync On)

**Table 17. DCI to DACCLK Setup and Hold Times vs. DCI Delay Value**

DCI Delay (Register 0x72, Bits[1:0])	Minimum Setup Time, $t_{SDCI}$ (ns)	Minimum Hold Time, $t_{HDCI}$ (ns)
00	-0.06	0.85
01	-0.22	1.14
10	-0.36	1.43
11	-0.45	1.59

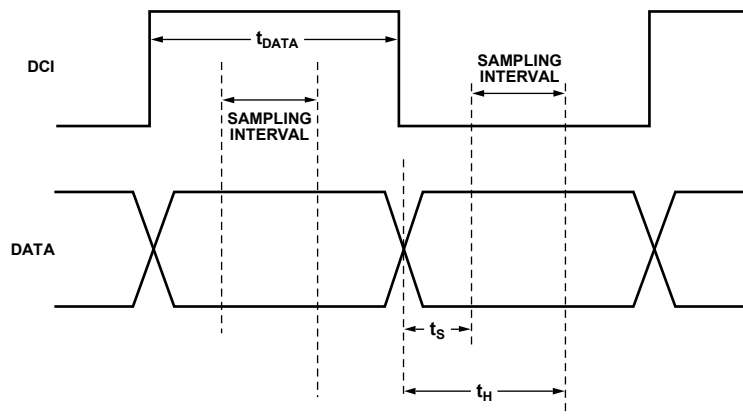

Figure 59. Timing Diagram for Input Data Ports

## DIGITAL DATA PATH

The block diagram in Figure 60 shows the functionality of the complex digital data path. The digital processing includes a premodulation block, a programmable complex filter, three half-band interpolation filters with built-in coarse modulation, a quadrature modulator with a fine resolution NCO as well as phase, gain, and offset adjustment blocks.

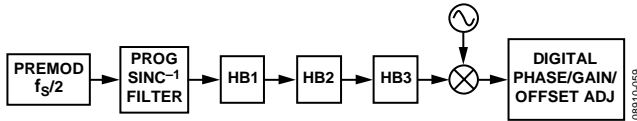

Figure 60. Block Diagram of Digital Data Path

There are two complex digital data paths that feed the four DACs. Each digital data path accepts I and Q data streams and processes them as a quadrature data stream, resulting in two quadrature data streams. All of the signal processing blocks can be used when the input data stream is represented as complex data.

The data path can be used to process an input data stream representing four independent real data streams as well; however, the functionality is somewhat restricted. The premodulation block can be used, as well as any of the nonshifted interpolation filter modes.

### PREMODULATION

The half-band interpolation filters have selectable pass bands that allow the center frequencies to be moved in increments of  $\frac{1}{2}$  of their input data rate. The premodulation block provides a digital upconversion of the incoming waveform by  $\frac{1}{2}$  of the incoming data rate,  $f_{\text{DATA}}$ . Functionally, the premodulation multiplies the incoming data samples alternatively by +1 and -1. This can be used to frequency shift baseband input data to the center of the interpolation filters pass band.

### PROGRAMMABLE INVERSE SINC FILTER

The AD9148 provides a programmable inverse sinc filter to compensate the DAC roll-off over frequency. Because this filter is implemented before the interpolation filter, its coefficients must be changed depending on the interpolation rate and DAC output center frequency.

### Filter Structure

The programmable inverse sinc filter is a nine-tap complex FIR filter using complex conjugate coefficients. The z-transfer function is

$$\begin{aligned} H(z) &= \frac{y_I + j \times y_Q}{x_I + j \times x_Q} = H_I + j \times H_Q \\ &= c_0 + c_1 \times z^{-1} + c_2 \times z^{-2} + c_3 \times z^{-3} + c_4 \times z^{-4} \\ &\quad + \bar{c}_3 \times z^{-5} + \bar{c}_2 \times z^{-6} + \bar{c}_1 \times z^{-7} + \bar{c}_0 \times z^{-8} \end{aligned}$$

where:

$x_I$  and  $x_Q$  are the in-phase (real) and quadrature (imaginary) filter input, respectively.

$y_I$  and  $y_Q$  are the in-phase (real) and quadrature (imaginary) filter output, respectively.

$H_I$  and  $H_Q$  are the in-phase (real) and quadrature (imaginary) filter coefficients, respectively.

$c_0, c_1, c_2, c_3,$  and  $c_4$  are the complex filter coefficient, and  $\bar{c}_x$  their complex conjugate.

The filter coefficients must be calculated and programmed into the AD9148 registers to perform the operation desired.

### Filter Implementation

To perform the complex filtering of the complex input, the filter is divided in four filters working in parallel, two sets of  $H_I$  and two sets of  $H_Q$  (see Figure 61).

$$\begin{aligned} y_I + j \times y_Q &= (H_I + j \times H_Q) \cdot (x_I + j \times x_Q) \\ &= H_I \times x_I - H_Q \times x_Q + j \cdot (H_Q \times x_I + H_I \times x_Q) \end{aligned}$$

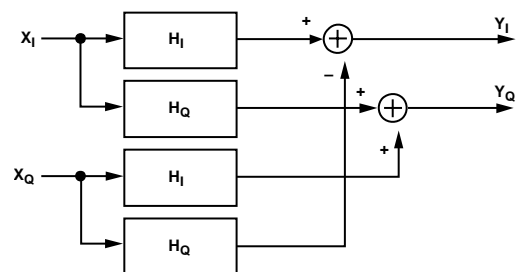

Figure 61. Complex Filter Implementation

The coefficients for the filter are stored in SPI Register 0x20 to Register 0x27 in two's-complement format. They have variable length, three bits to 10 bits.

Table 18. Programmable Inverse Sinc Filter Coefficient Widths and Ranges

Coefficient	Width	Minimum	Maximum
c <sub>0</sub> in-phase (real)	3	100b -4	011b 3
c <sub>0</sub> quadrature (imaginary)	3	0100b -4	011b 3
c <sub>1</sub> in-phase (real)	4	1000b -8	0111b 7
c <sub>1</sub> quadrature (imaginary)	4	1000b -8	0111b 7
c <sub>2</sub> in-phase (real)	5	10000b -16	01111b 15
c <sub>2</sub> quadrature (imaginary)	5	10000b -16	01111b 15
c <sub>3</sub> in-phase (real)	7	1000000b -64	0111111b 63
c <sub>3</sub> quadrature (imaginary)	7	1000000b -64	0111111b 63
c <sub>4</sub> in-phase (real)	10	100000000b -1024	011111111b 1023
c <sub>4</sub> quadrature (imaginary)	10	100000000b -1024	011111111b 1023

The real and imaginary filters are implemented using the structure described in Figure 62 and Figure 63.

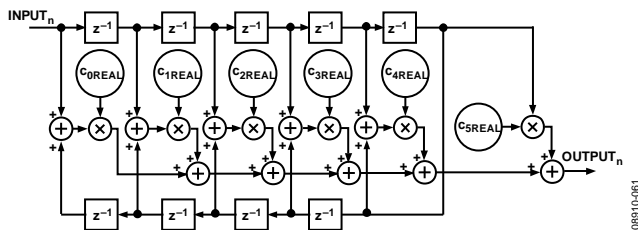

Figure 62. Real Filter implementation

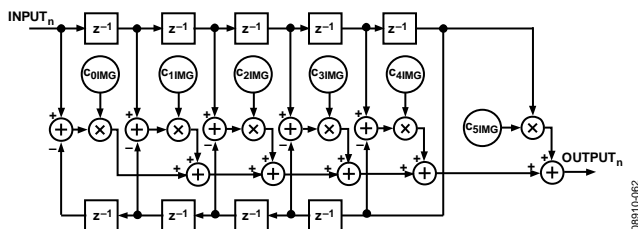

Figure 63. Imaginary Filter implementation

The AD9148 evaluation tools provide software that allows for the processing of the filter coefficients based on the DAC sampling frequency, the amount of interpolation used (combination of HB1, HB2, and HB3), and the desired center frequency. This center frequency is limited to

$$[-0.4 \times f_{DAC} + 0.5 \times \text{signalBW}, 0.4 \times f_{DAC} - 0.5 \times \text{signalBW}]$$

The bandwidth of the inverse sinc filter equals the maximum allowable signal bandwidth of the interpolation filters ( $0.8 \times f_{DATA}$ ).

When there is no interpolation used, the real filter coefficients can be fixed at (no imaginary coefficients)

$$\begin{aligned} C_0 &= 2 & ; & & C_8 &= 2 \\ C_1 &= -4 & ; & & C_7 &= -4 \\ C_2 &= 10 & ; & & C_6 &= 10 \\ C_3 &= -35 & ; & & C_5 &= -35 \\ C_4 &= 401 & & & & \end{aligned}$$

### INTERPOLATION FILTERS

The transmit path contains three interpolation filters. Each of the three interpolation filters provides a 2x increase in output data rate. The filters can be cascaded to provide 2x, 4x, or 8x interpolation ratios. Each of the half-band filter stages offers a different combination of bandwidths and operating modes.

The bandwidth of the three half-band filters with respect to the data rate at the filter input is as follows:

- Bandwidth of HB1 =  $0.8 \times f_{IN1}$
- Bandwidth of HB2 =  $0.5 \times f_{IN2}$
- Bandwidth of HB3 =  $0.4 \times f_{IN3}$

The usable bandwidth is defined as the frequency over which the filters have a pass-band ripple of less than  $\pm 0.001$  dB and an image rejection of greater than +85 dB. As is discussed in the Half-Band Filter 1 (HB1) section, the image rejection usually sets the usable bandwidth of the filter, not the pass-band flatness.

The half-band filters operate in several modes, providing programmable pass-band center frequencies as well as signal modulation. The HB1 filter has four modes of operation, and the HB2 and HB3 filters each have eight modes of operation.

**Half-Band Filter 1 (HB1)**

HB1 has four modes of operation, as shown in Figure 64. The shape of the filter response is identical in each of the four modes. The four modes are distinguished by two factors: the filter center frequency and whether the filter modulates the input signal.

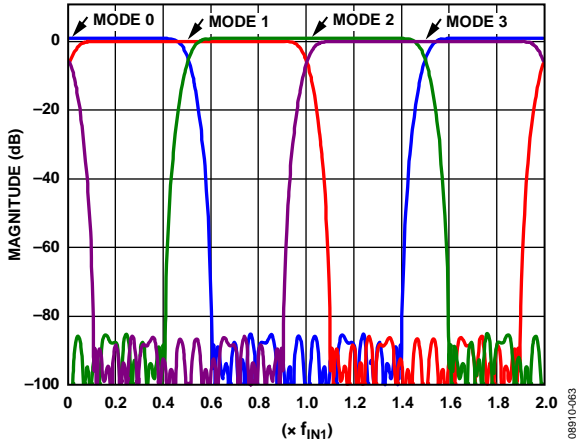

Figure 64. HB1 Filter Modes

As is shown in Figure 64, the center frequency in each mode is offset by 1/2 of the input data rate ( $f_{IN1}$ ) of the filter. Mode 0 and Mode 1 do not modulate the input signal. Mode 2 and Mode 3 modulate the input signal by  $f_{IN1}$ . When operating in Mode 0 and Mode 2, the I and Q paths operate independently and no mixing of the data between channels occurs. When operating in Mode 1 and Mode 3, mixing of the data between the I and Q paths occurs; therefore, the data input into the filter is assumed complex. Table 19 summarizes the HB1 modes.

**Table 19. 2x Interpolation Filter Modes (Register 0x1C to Register 0x1E)**

Interpolation Factor	Filter Modes				$f_{CENTER}$ ( $f_{DAC}$ )
	Pre-Mod	HB1	HB2	HB3	
2	0	0	Off	Off	0
2	1	1	Off	Off	$f_{DAC}/4$
2	0	2	Off	Off	$f_{DAC}/2$
2	1	3	Off	Off	$-f_{DAC}/4$

Figure 65 shows the pass-band filter response for HB1. In most applications, the usable bandwidth of the filter is limited by the image suppression provided by the stop-band rejection and not by the pass-band flatness. Table 20 shows the pass-band flatness and stop-band rejection the HB1 filter supports at different bandwidths.

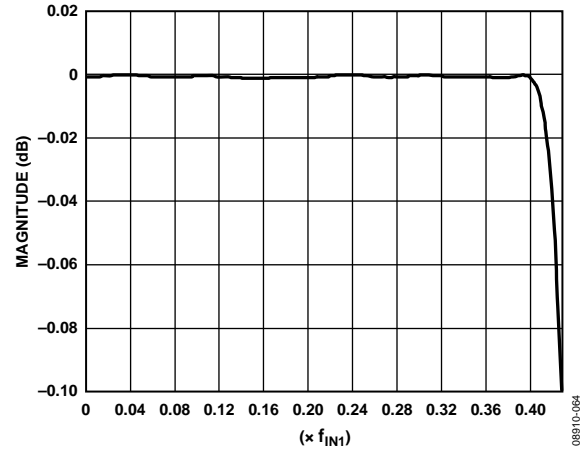

Figure 65. Pass-Band Detail of HB1

**Table 20. HB1 Pass-Band and Stop-Band Performance by Bandwidth**

Bandwidth (% of $f_{IN1}$ )	Pass-Band Flatness (dB)	Stop-Band Rejection (dB)
80	0.001	85
80.4	0.0012	80
81.2	0.0033	70
82.0	0.0076	60
83.6	0.0271	50
85.6	0.1096	40

**Half-Band Filter 2 (HB2)**

HB2 has eight modes of operation, as shown in Figure 66 and Figure 67. The shape of the filter response is identical in each of the eight modes. The eight modes are distinguished by two factors, the filter center frequency and whether the input signal is modulated by the filter.

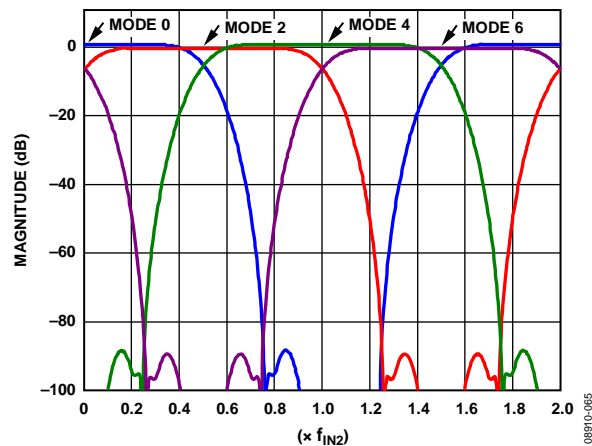

Figure 66. HB2, Even Filter Modes

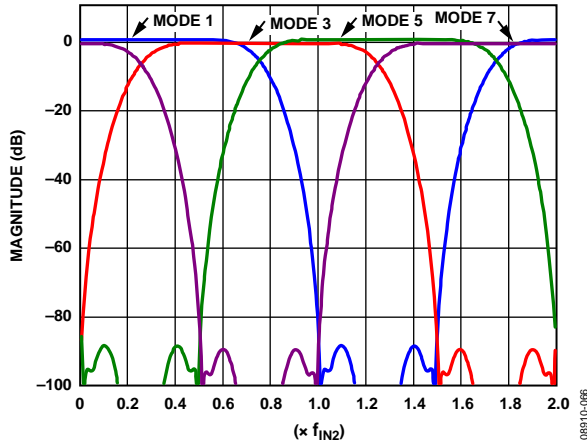

Figure 67. HB2, Odd Filter Modes

As shown in Figure 66 and Figure 67, the center frequency in each mode is offset by  $\frac{1}{4}$  of the input data rate ( $f_{IN2}$ ) of the filter. Mode 0 through Mode 3 do not modulate the input signal. Mode 4 through Mode 7 modulate the input signal by  $f_{IN2}$ . When operating in Mode 0 and Mode 4, the I and Q paths operate independently, and no mixing of the data between channels occurs. When operating in the other six modes, mixing of the data between the I and Q paths occurs; therefore, the data input to the filter is assumed complex. Table 21 summarizes the HB2 modes.

Table 21. 4x Interpolation Filter Modes (Register 0x1C to Register 0x1E)

Interpolation Factor	Filter Modes				$f_{CENTER}$ ( $f_{DAC}$ )
	Pre-Mod	HB1	HB2	HB3	
4	0	0	0	Off	0
4	1	1	1	Off	$f_{DAC}/8$
4	0	2	2	Off	$f_{DAC}/4$
4	1	3	3	Off	$3f_{DAC}/8$
4	0	0	4	Off	$f_{DAC}/2$
4	1	1	5	Off	$-3f_{DAC}/8$
4	0	2	6	Off	$-f_{DAC}/4$
4	1	3	7	Off	$-f_{DAC}/8$

Figure 68 shows the pass-band filter response for HB2. In most applications, the usable bandwidth of the filter is limited by the image suppression provided by the stop-band rejection and not by the pass-band flatness. Table 22 shows the pass-band flatness and stop-band rejection the HB2 filter supports at different bandwidths.

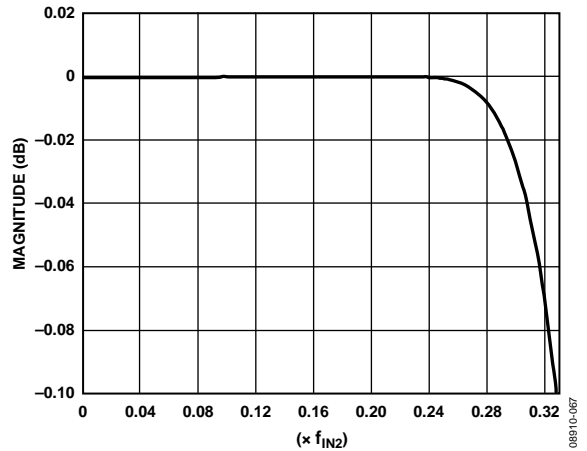

Figure 68. Pass-Band Detail of HB2

Table 22. HB2 Pass-Band and Stop-Band Performance by Bandwidth

Bandwidth (% of $f_{IN2}$ )	Pass-Band Flatness (dB)	Stop-Band Rejection (dB)
50	0.001	85
50.8	0.0012	80
52.8	0.0028	70
56.0	0.0089	60
60	0.0287	50
64.8	0.1877	40

**Half-Band Filter 3 (HB3)**

HB3 has eight modes of operation that function the same as HB2. The primary difference between HB2 and HB3 are the filter bandwidths. Table 23 summarizes the filter modes for HB3.

Table 23. 8x Interpolation Filter Modes (Register 0x1C to Register 0x1E)

Interpolation Factor	Filter Modes				$f_{CENTER}$ ( $f_{DAC}$ )
	Pre-Mod	HB1	HB2	HB3	
8	0	0	0	0	0
8	0	2	2	1	$f_{DAC}/8$
8	0	0	4	2	$f_{DAC}/4$
8	0	2	6	3	$3f_{DAC}/8$
8	0	0	0	4	$f_{DAC}/2$
8	0	2	2	5	$-3f_{DAC}/8$
8	0	0	4	6	$-f_{DAC}/4$
8	0	2	6	7	$-f_{DAC}/8$

Figure 69 shows the pass-band filter response for HB3. In most applications, the usable bandwidth of the filter is limited by the image suppression provided by the stop-band rejection and not by the pass-band flatness. Table 24 shows the pass-band flatness and stop-band rejection the HB3 filter supports at different bandwidths.

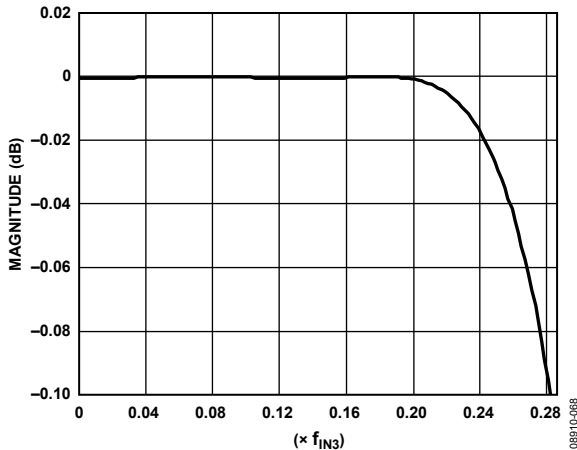

Figure 69. Pass-Band Detail of HB3

Table 24. HB3 Pass-Band and Stop-Band Performance by Bandwidth

Bandwidth (% of $f_{IN3}$ )	Pass-Band Flatness (dB)	Stop-Band Rejection (dB)
40	0.001	85
40.8	0.0014	80
42.4	0.002	70
45.6	0.0093	60
49.8	0.03	50
55.6	0.1	40

The maximum bandwidth can be achieved if the signal carrier frequency is placed directly at the center of one of the filter pass bands. In this case, the entire quadrature bandwidth of the interpolation filter ( $0.8 \times f_{DATA}$ ) is available. The available signal bandwidth decreases as the carrier frequency of the signal moves away from the center frequency of the filter. The worst-case carrier frequency is one that falls directly between the center frequency of two adjacent filters. Figure 70 shows how the signal bandwidth changes as a function of placement in the spectrum and interpolation rate.

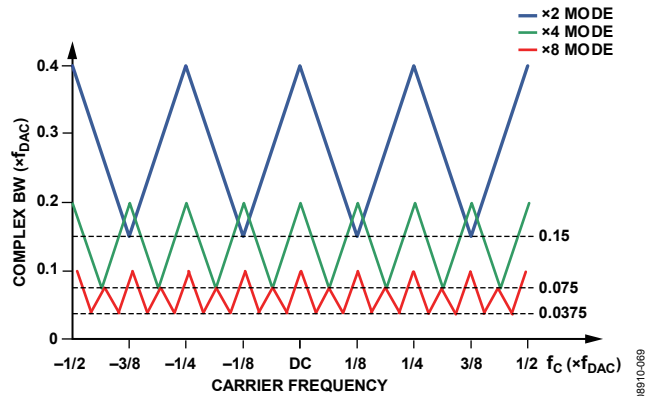

Figure 70. Complex Signal Bandwidth as a Function of Output Frequency

### FINE MODULATION

The fine modulation makes use of a numerically controlled oscillator, a phase shifter, and a complex modulator to provide a means for modulating the signal by a programmable carrier signal. A block diagram of the fine modulator is shown in Figure 71. The fine modulator allows the signal to be placed anywhere in the output spectrum with very fine frequency resolution.

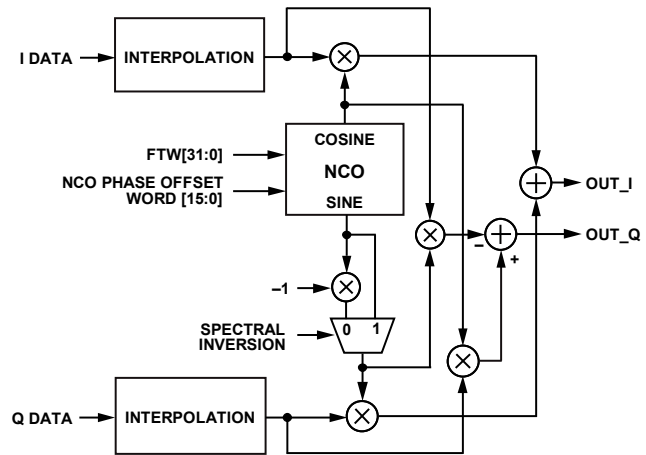

Figure 71. Fine Modulator Block Diagram

The quadrature modulator is used to mix the carrier signal generated by the NCO with the I and Q signal. The NCO produces a quadrature carrier signal to translate the input signal to a new center frequency. A complex carrier signal is a pair of sinusoidal waveforms of the same frequency, offset  $90^\circ$  from each other. The frequency of the complex carrier signal is set via the FTW[31:0] value in Register 0x54 through Register 0x57.

The NCO operating frequency,  $f_{NCO}$ , is at the DAC rate. The frequency of the complex carrier signal can be set from dc up to  $f_{DAC}/2$ . The frequency tuning word (FTW) is calculated as

$$FTW = \frac{f_{CENTER}}{f_{DAC}} \times 2^{32}$$

The generated quadrature carrier signal is mixed with the I and Q data. The quadrature products are then summed into the I and Q data paths, as shown in Figure 71.

When using the fine modulator, the maximum signal bandwidth of  $0.8 \times f_{\text{DATA}}$  is always achieved.

### Updating the Frequency Tuning Word

The frequency tuning word registers are not updated immediately upon writing as the other configuration registers do. After loading the FTW registers with the desired values, Bit 2 of Register 0x5A must transition from 0 to 1 for the new FTW to take effect.

### Phase Offset Adjustment

A 16-bit phase offset may be added to the output of the phase accumulator via the serial port. This static phase adjustment results in an output signal that is offset by a constant angle relative to the nominal signal. This allows the user to phase align the NCO output with some external signal, if necessary. This can be especially useful when NCOs of multiple AD9148s are programmed for synchronization. The phase offset allows for the adjustment of the output timing between the devices. The static phase adjustment is sourced from the NCO Phase Offset[15:0] value located in Register 0x58 and Register 0x59.

### QUADRATURE PHASE CORRECTION

The purpose of the quadrature phase correction block is to enable compensation of the phase imbalance of the analog quadrature modulator following the DAC. If the quadrature modulator has a phase imbalance, the unwanted sideband appears with significant energy. Tuning the quadrature phase adjust value can optimize image rejection in single sideband radios.

Ordinarily, the I and Q channels have an angle of precisely  $90^\circ$  between them. The quadrature phase adjustment is used to change the angle between the I and Q channels. When I Phase Adj, Bits[9:0] (Register 0x28 and Register 0x29), are set to 100000000b, the I DAC output moves approximately  $1.75^\circ$  away from the Q DAC output, creating an angle of  $91.75^\circ$  between the channels. When I Phase Adj, Bits[9:0] (Register 0x28 and Register 0x29), are set to 011111111b, the I DAC output moves approximately  $1.75^\circ$  toward the Q DAC output, creating an angle of  $88.25^\circ$  between the channels.

Q Phase Adj, Bits[9:0] (Register 2A and Register 2B), work in a similar fashion. When Q Phase Adj, Bits[9:0] (Register 2A and Register 2B), are set to 100000000b, the Q DAC output moves approximately  $1.75^\circ$  away from the I DAC output, creating an angle of  $91.75^\circ$  between the channels. When Q Phase Adj[9:0] is set to 011111111b, the Q DAC output moves approximately  $1.75^\circ$  toward the I DAC output, creating an angle of  $88.25^\circ$  between the channels.

Based on these two endpoints, the combined resolution of the phase compensation register is approximately  $3.5^\circ/1024$  or  $0.00342^\circ$  per code. When both I Phase Adj, Bits[9:0] (Register 0x28 and Register 0x29), and Q Phase Adj, Bits[9:0] (Register 2A and Register 2B), are used, the full phase adjustment range is  $\pm 3.5^\circ$ .

### DC OFFSET CORRECTION

The dc value of the I data path and the Q data path can be independently controlled by adjusting I DC Offset, Bits[15:0], and Q DC Offset, Bits[15:0], values in Register 0x2C through Register 0x2F. These values are added directly to the data path values. Care should be taken not to overrange the transmitted values.

Figure 72 shows how the DAC offset current varies as a function of I DC Offset, Bits[15:0], and Q DC Offset, Bits[15:0], values. With the digital inputs fixed at midscale (0x000, twos complement data format), Figure 72 shows the nominal  $I_{\text{OUTXP}}$  and  $I_{\text{OUTXN}}$  currents as the DC offset value is swept from 0 to 65,535. Because  $I_{\text{OUTXP}}$  and  $I_{\text{OUTXN}}$  are complementary current outputs, the sum of  $I_{\text{OUTXP}}$  and  $I_{\text{OUTXN}}$  is always 20 mA.

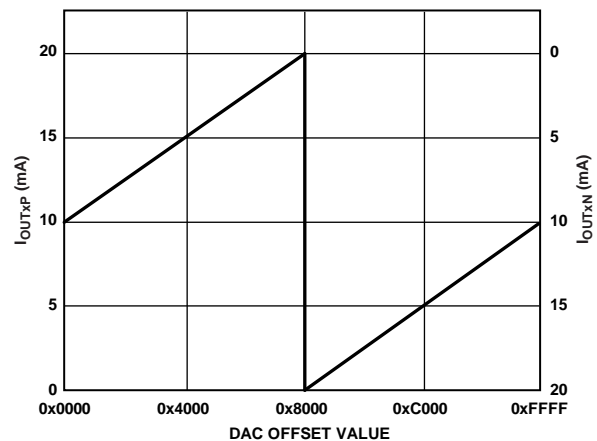

Figure 72. DAC Output Currents vs. DC Offset Value

### DIGITAL GAIN CONTROL

The last block in each datapath is an 8-bit scalar (Register 0x50 and Register 0x51) that can be used for digital gain control. The I Gain Control, Bits[7:0] (Register 0x50), and Q Gain control, Bits[7:0] (Register 0x51), values directly scale the samples written to the IDAC and QDAC, respectively. The bit weighting is  $\text{MSB} = 2^1$  and  $\text{LSB} = 2^{-6}$ , which yields a multiplier range of 0 to 3.984375. The scale factor for each data path is calculated as

$$\text{ScaleFactor} = \frac{I\text{Gain}[7:0]}{64} \text{ or } \frac{Q\text{Gain}[7:0]}{64}$$

Take care not to overrange the DAC when using a scale factor greater than 1.

## CLOCK GENERATION

### DAC INPUT CLOCK CONFIGURATIONS

The AD9148 DAC sample clock (DACCLK) can be sourced directly or by clock multiplying. Clock multiplying employs the on-chip, phased-locked loop (PLL) that accepts a reference clock (REFCLK\_x) operating at a submultiple of the desired DACCLK rate, most commonly the data input frequency. The PLL then multiplies the reference clock up to the desired DACCLK frequency, which can then be used to generate all the internal clocks required by the DAC. The clock multiplier provides a high quality clock that meets the performance requirements of most applications. Using the on-chip clock multiplier removes the burden of generating and distributing the high speed DACCLK.

The second mode bypasses the clock multiplier circuitry and allows DACCLK to be sourced directly through the CLK\_x pins. This mode enables the user to source a very high quality clock directly to the DAC core. Sourcing the DACCLK directly through the CLK\_x pins may be necessary in demanding applications that require the lowest possible DAC output noise, particularly at higher output frequencies.

### DRIVING THE CLK\_x AND REFCLK\_x INPUTS

The REFCLK\_x and CLK\_x differential inputs share similar clock receiver input circuitry. Figure 1 shows a simplified circuit diagram of the input, along with a recommended drive circuit. The on-chip clock receiver has a differential input impedance of about 10 k $\Omega$ . It is self-biased to a common-mode voltage of about 1.25 V. The recommended circuit for driving the input is a pair of ac coupling capacitors and a differential 100  $\Omega$  termination.

The minimum input drive level to either of the clock inputs is 100 mV ppd. The optimal performance is achieved when the clock input signal is between 500 mV ppd and 1.6 V ppd. Whether using the on-chip clock multiplier or sourcing the DACCLK directly, it is necessary that the input clock signal to the device have low jitter and fast edge rates to optimize the DAC noise performance.

### DIRECT CLOCKING

When a high quality, sample rate clock is connected to the AD9148, it provides the lowest noise spectral density at the DAC outputs. To select the differential CLK inputs as the source for the DAC sampling clock, set the PLL enable bit to 0 (Register 0x0A, Bit 7). Setting this bit to 0 powers down the internal PLL clock multiplier and selects the input from the CLK\_x pins as the source for the internal DACCLK.

The device also has duty-cycle correction circuitry and differential input level correction circuitry. Enabling these circuits may provide improved performance in some cases. The control bits for these functions can be found in Register 0x08.

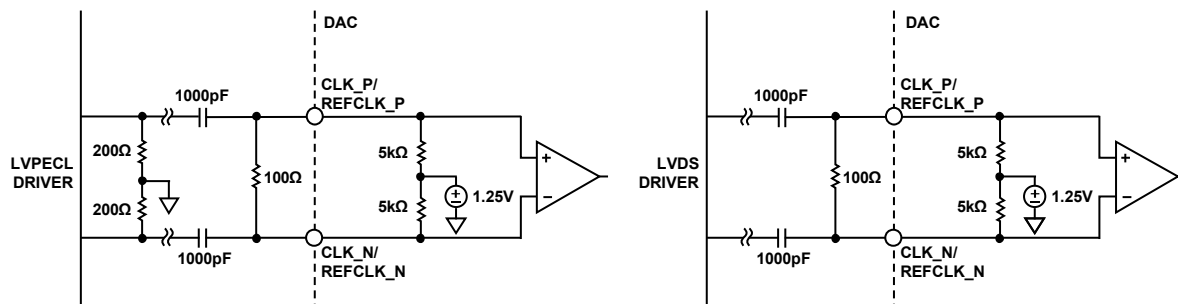

Figure 73. Clock Receiver Circuitry and Recommended Drive Circuitry using LVPECL (Left) and LVDS (Right)

08910-071

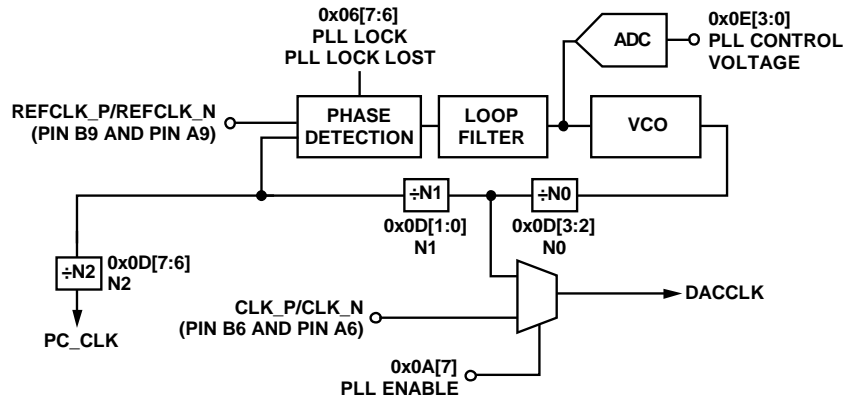

Figure 74. PLL Clock Multiplication Circuit

Table 25. PLL Settings

PLL SPI Control	Address		Optimal Setting
	Register	Bit	
PLL Loop Bandwidth	0x0C	[7:5]	110
PLL Control 1 Register	0x0C	[4:0]	01001
PLL Cross Control Enable	0x0D	[4]	1

### CLOCK MULTIPLICATION

The on-chip PLL clock multiplier circuit can be used to generate the DAC sample rate clock from a lower frequency reference clock. When the PLL clock multiplier is enabled (Register 0x0A[7] = 1), the clock multiplication circuit generates the DAC sample clock from the lower rate REFCLK input. The functional diagram of the clock multiplier is shown in Figure 74.

The clock multiplication circuit operates such that the VCO outputs a frequency,  $f_{VCO}$ , equal to the REFCLK input signal frequency multiplied by  $N0 \times N1$ .

$$f_{VCO} = f_{REFCLK} \times (N0 \times N1)$$

The DAC sample clock frequency,  $f_{DACCLK}$ , is equal to

$$f_{DACCLK} = f_{REFCLK} \times N1$$

The output frequency of the VCO must be chosen to keep  $f_{VCO}$  in the optimal operating range of 1.0 GHz to 2.1 GHz. The frequency of the reference clock and the values of N1 and N0 must be chosen so that the desired DACCLK frequency can be synthesized and the VCO output frequency is in the correct range.

### PLL Bias Settings

There are four bias settings for the PLL circuitry that should be programmed to their nominal values. The PLL values shown in Table 25 are the recommended settings for these parameters.

### Configuring the VCO Tuning Band

The PLL VCO has a valid operating range from approximately 1.0 GHz to 2.1 GHz covered in 63 overlapping frequency bands. For any desired VCO output frequency, there may be several valid PLL band select values. The frequency bands of a typical device are shown in Figure 75. Device-to-device variations and operating temperature affect the actual band frequency range.

Therefore, it is required that the optimal PLL band select value be determined for each individual device.

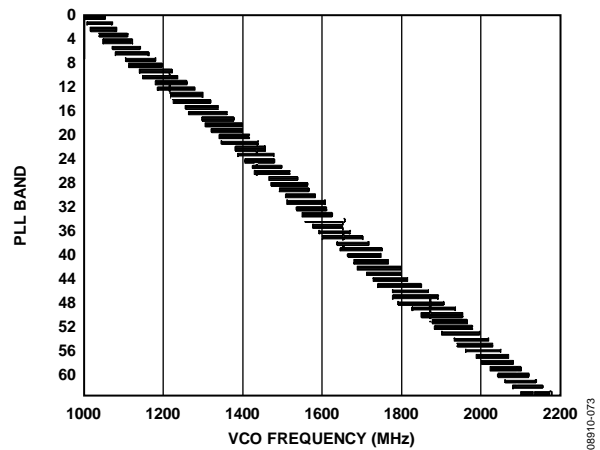

Figure 75. PLL Lock Range Overtemperature for a Typical Device

### Automatic VCO Band Select

The device has an automatic VCO band select feature on chip; using this feature is a simple and reliable method for configuring the VCO frequency band. To use the automatic VCO band select feature, enable the PLL by writing 0xC0 to Register 0x0A and enable the auto band select mode by writing 0x80 to Register 0x0A. When this value is written, the device executes an automated routine that determines the optimal VCO band setting for the device. The setting selected by the device ensures that the PLL remains locked over the full  $-40^{\circ}\text{C}$  to  $+85^{\circ}\text{C}$  operating temperature range of the device without further adjustment. (The PLL remains locked over the full temperature range even if the temperature during initialization is at one of the temperature extremes.)

**Manual VCO Band Select**

The device also has a manual band select mode that allows the user to select the VCO tuning band. When in manual mode (enabled by setting Bit 6, Register 0x0A to 1), the VCO band is set directly with the value written to the manual VCO band bit enabled (Bits[5:0], Register 0x0A). To properly select the VCO band, complete the following sequence:

1. Put the device in manual band select mode.
2. Sweep the VCO band over a range of bands that results in the PLL being locked.
3. Verify that the PLL is locked and read the VCO control voltage for each band.
4. Select the band that results in the control voltage being closest to the center of the range (that is, 1000). See Table 26 for more details.

The resulting VCO band should be the optimal setting for the device. This band should be written to the manual VCO band register value.

If desired, an indication of where the VCO is within the operating frequency band can be determined by querying the VCO control voltage. Table 26 shows how to interpret the VCO control voltage value.

**Table 26. VCO Control Voltage Range Indications**

VCO Control Voltage	Indication
1111	Move to a higher VCO band.
1110	
1101	VCO is operating in the higher end of frequency band.
1100	
1011	
1010	
1001	VCO is operating with an optimal region of the frequency band.
1000	
0111	
0110	
0101	VCO is operating in the lower end of frequency band.
0100	
0011	
0010	
0001	Move to a lower VCO band.
0000	

## ANALOG OUTPUTS

### TRANSMIT DAC OPERATION

Figure 77 shows a simplified block diagram of one pair of the transmit path DACs. The DAC core consists of a current source array, switch core, digital control logic, and full-scale output current control. The DAC full-scale output current ( $I_{OUTFS}$ ) is nominally 20 mA. The output currents from the  $IOUT_{x\_P}$  and  $IOUT_{x\_N}$  pins are complementary, meaning that the sum of the two currents always equals the full-scale current of the DAC. The digital input code to the DAC determines the effective differential current delivered to the load.

The DAC has a 1.2 V band gap reference with an output impedance of 5 k $\Omega$ . The reference output voltage appears on the VREF pin. When using the internal reference, the VREF pin should be decoupled to AVSS with a 0.1  $\mu$ F capacitor. The internal reference should only be used for external circuits that draw dc currents of 2  $\mu$ A or less. For dynamic loads or static loads greater than 2  $\mu$ A, the VREF pin should be buffered. If desired, an external reference (between 1.10 V to 1.30 V) can be applied to the VREF pin.

A 10 k $\Omega$  external resistor,  $R_{SET}$ , must be connected from the RESET pin to AVSS. This resistor, along with the reference control amplifier, sets up the correct internal bias currents for the DAC. Because the full-scale current is inversely proportional to this resistor, the tolerance of  $R_{SET}$  is reflected in the full-scale output amplitude.

The full-scale current can be calculated by

$$I_{OUTFS} = \frac{V_{REF}}{R_{SET}} \times \left( 72 + \left( \frac{3}{16} \times DAC\ gain \right) \right)$$

where *DAC gain* is set individually for the I and Q DACs in Register 0x30, Register 0x31, Register 0x34, and Register 0x35, respectively.

For nominal values of  $V_{REF}$  (1.2 V),  $R_{SET}$  (10 k $\Omega$ ), and DAC gain (512), the full-scale current of the DAC is typically 20.16 mA. The DAC full-scale current can be adjusted from 8.66 mA to 31.66 mA by setting the DAC gain parameter setting as shown in Figure 76.

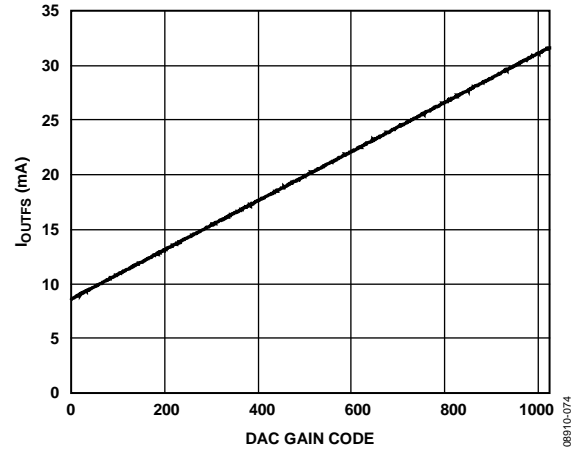

Figure 76. DAC Full-Scale Current vs. DAC Gain Code

### Transmit DAC Transfer Function

The output currents from the  $IOUT_{x\_P}$  and  $IOUT_{x\_N}$  pins are complementary, meaning that the sum of the two currents always equals the full-scale current of the DAC. The digital input code to the DAC determines the effective differential current delivered to the load.  $IOUT_{x\_P}$  provides the maximum output current when all bits are high. The output currents vs. DACCODE for the DAC outputs are expressed as

$$I_{OUT\_P} = \left[ \frac{DACCODE}{2^N} \right] \times I_{OUTFS} \tag{1}$$

$$I_{OUT\_N} = I_{OUTFS} - I_{OUT\_P} \tag{2}$$

where  $DACCODE = 0$  to  $2^N - 1$ .

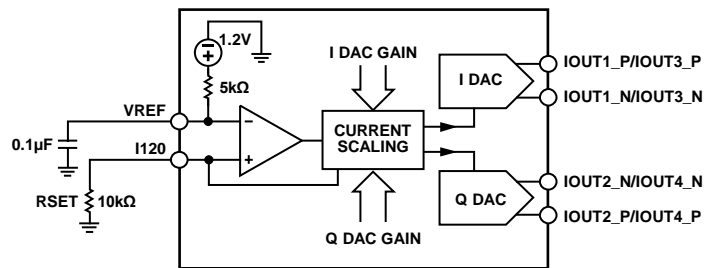

Figure 77. Simplified Block Diagram of the DAC Core



In addition, the P or N output can act as a current source or a current sink. When sourcing current, the output compliance voltage is 0 V to 1.6 V. When sinking current, the output compliance voltage is 0.8 V to 1.6 V. The auxiliary DAC current direction is programmable via Bit 6, Register 0x33 and Bit 6, Register 0x37 (DAC SPI select is 0 to control AUX1 and AUX2, and DAC SPI select is 1 to control AUX3 and AUX4). The choice of sinking or sourcing should be made at circuit design time. There is no advantage to switching between sourcing and sinking current after the circuit is in place.

These auxiliary DACs can be used for local oscillator (LO) cancellation when the DAC output is followed by a quadrature modulator. More information and example application circuits are given in the Interfacing to Modulators section.

**INTERFACING TO MODULATORS**

The AD9148 interfaces to the ADL537x family with a minimal number of components. An example of the recommended interface circuitry is shown in Figure 81.

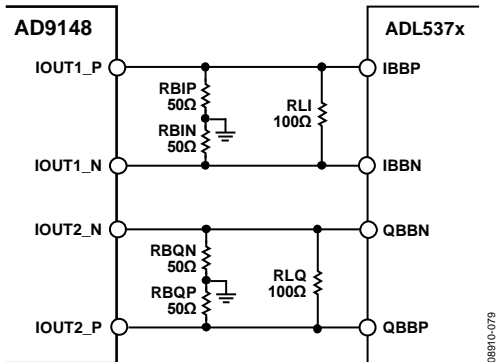

Figure 81. Typical Interface Circuitry Between the AD9148 and ADL537x Family of Modulators

The baseband inputs of the ADL537x family require a dc bias of 500 mV. The nominal midscale output current on each output of the DAC is 10 mA (1/2 the full-scale current). Therefore, a single 50 Ω resistor to ground from each of the DAC outputs results in the desired 500 mV dc common-mode bias for the inputs to the ADL537x. The signal level can be reduced by the addition of the load resistor in parallel with the modulator inputs (RLI, RLQ). The peak-to-peak voltage swing of the transmitted signal is

$$V_{SIGNAL} = I_{FS} \times \left[ \frac{2 \times R_B \times R_L}{2 \times R_B + R_L} \right]$$

**Baseband Filter Implementation**

Most applications require a baseband anti-imaging filter between the DAC and modulator to filter out Nyquist images and broadband DAC noise. The filter can be inserted between the I-to-V resistors at the DAC output and the signal level setting resistor across the modulator input. Doing this establishes the input and output impedances for the filter.

Figure 83 shows a fifth-order low-pass filter. A common-mode choke is used between the I-to-V resistors and the remainder of the filter. This removes the common-mode signal produced by the DAC and prevents the common-mode signal from being converted to a differential signal, which would appear as unwanted spurious signals in the output spectrum. The common-mode choke or balun may not be needed if the layout between the DAC and IQ modulator is optimized and balanced. Splitting the second filter capacitor into two and grounding the center point creates a common-mode low-pass filter, providing additional common-mode rejection of high frequency signals. A purely differential filter passes common-mode signals.

**Driving the ADL5375-15 with the AD9148**

The ADL5375-15 requires a 1500 mV dc bias and therefore requires a slightly more complex interface than most other Analog Devices, Inc., modulators. It is necessary to level shift the DAC output from a 500 mV dc bias to the 1500 mV dc bias that the ADL5375-15 requires. Level shifting can be achieved with a purely passive network, as shown in Figure 82. In this network, the dc bias of the DAC remains at 500 mV, while the input to the ADL5375-15 is 1500 mV. Note that this passive level shifting network introduces approximately 2 dB of loss in the ac signal.

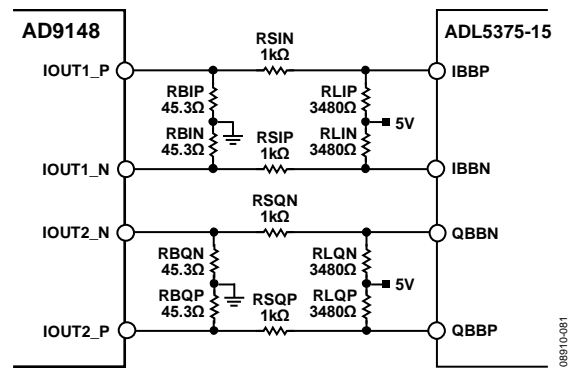

Figure 82. Passive Level Shifting Network for Biasing the ADL5375-15 from the AD9148

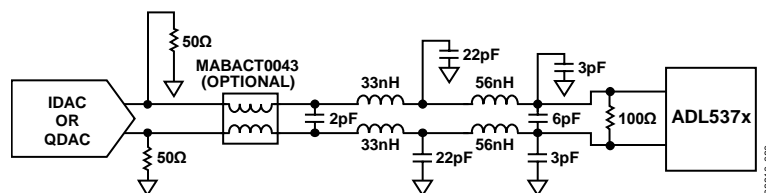

Figure 83. DAC Modulator Interface with Fifth-Order, Low Pass Filter

**Reducing LO Leakage and Unwanted Sidebands**

Analog Devices modulators can introduce unwanted signals at the LO frequency due to dc offset voltages in the I and Q baseband inputs as well as feedthrough paths from the LO input to the output. The LO feedthrough can be nulled by applying the correct dc offset voltages at the DAC output. This can be done either by using the auxiliary DACs (Register 0x32, Register 0x33, Register 0x36, and Register 0x37) or by using the digital dc offset adjustments (Register 0x2C to Register 0x2F). Using the auxiliary DACs has the advantage that none of the main DAC dynamic range is used for performing the dc offset adjustment. The disadvantage is that the common-mode level of the output signal changes as a function of the auxiliary DAC current. The opposite is true when the digital offset adjustment is used.

Good sideband suppression requires both gain and phase matching of the I and Q signals. The phase adjust (Register 0x28 to Register 0x2B) and gain control (Register 0x50 and Register 0x51) registers can be used to calibrate I and Q transmit paths to optimize the sideband suppression. As an alternative to the digital gain scaling, the DAC full-scale output current (Register 0x30, Register 0x31, Register 0x34, and Register 0x35) can also be adjusted to calibrate the I and Q transmit paths; however, changing the DAC full-scale output current affects the common-mode voltage level.

For more information on correcting imperfections in IQ modulators to improve RF signal fidelity, refer to the [AN-1039 Application Note](#).

## DEVICE POWER DISSIPATION

The AD9148 has four supply rails: AVDD33, IOVDD, DVDD18, and CVDD18.

The AVDD33 supply powers the DAC core circuitry. The power dissipation of the AVDD33 supply rail is independent of the digital operating mode and sample rate. The current drawn from the AVDD33 supply rail is typically 98 mA (320 mW) when the full-scale current of the four main DACs (DAC 1, DAC 2, DAC 3, and DAC 4) is set to the nominal value of 20 mA. Changing the full-scale current directly impacts the supply current drawn from the AVDD33 rail. For example, if the full-scale current of the four main DACs is changed to 10 mA, the AVDD33 supply current drops by 40 mA to 58 mA.

The IOVDD voltage supplies the serial port I/O pins (SCLK, SDIO, SDO, CSB, TCK, TDI, TDO, TMS), the  $\overline{\text{RESET}}$  pin, and the  $\overline{\text{IRQ}}$  pin. The voltage applied to the IOVDD pin can range from 1.8 V to 3.3 V. The current drawn by the IOVDD supply pin is typically 1 mA.

The DVDD18 supply powers all of the digital signal processing blocks of the device. The power consumption from this supply is a function of which digital blocks are enabled and the frequency at which the device is operating.

The CVDD18 supply powers the clock receiver and clock distribution circuitry. The power consumption from this supply varies directly with the operating frequency of the device. CVDD18 also powers the PLL. The power dissipation of the PLL is typically 80 mW.

Figure 84 to Figure 89 detail the power dissipation of the AD9148 under a variety of operating conditions. All of the graphs are taken with data being supplied to all four DACs. The power consumption of the device does not vary significantly with changes in the coarse modulation mode selected or analog output frequency. Graphs of the total power dissipation are shown along with the power dissipation of the DVDD18 and CVDD18 supplies.

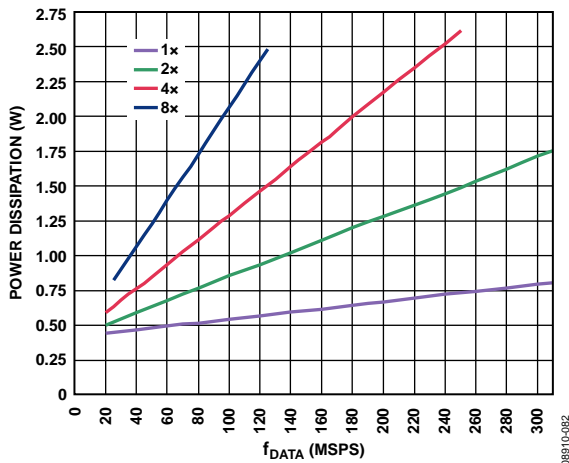

Figure 84. Total Power Dissipation vs.  $f_{\text{DATA}}$  with Coarse Modulation, PLL, and Inverse Sinc Filter Disabled

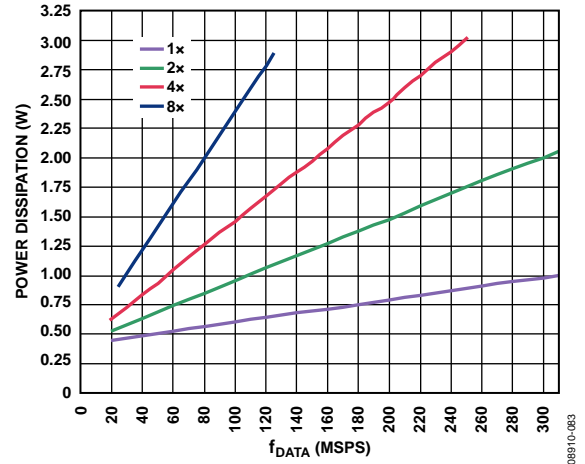

Figure 85. Total Power Dissipation vs.  $f_{\text{DATA}}$  with Fine Modulation, PLL, and Inverse Sinc Filter Disabled

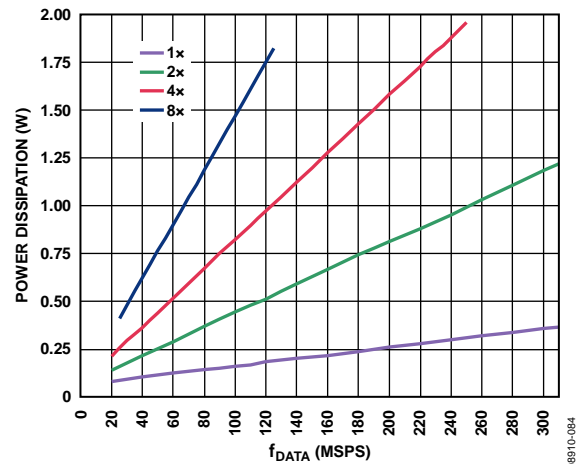

Figure 86. DVDD18 Power Dissipation vs.  $f_{\text{DATA}}$  with Coarse Modulation, PLL, and Inverse Sinc Filter Disabled

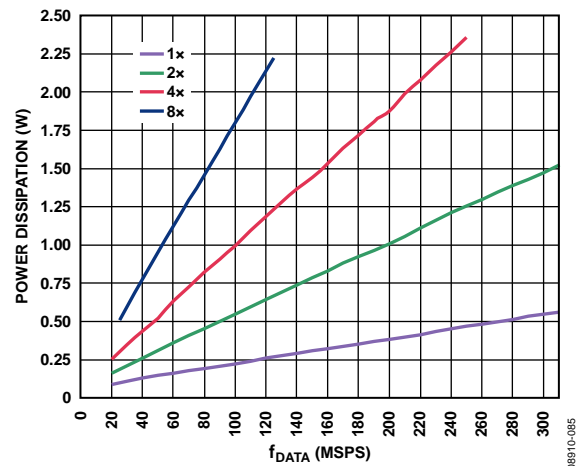

Figure 87. DVDD18 Power Dissipation vs.  $f_{\text{DATA}}$  with Fine Modulation, PLL, and Inverse Sinc Filter Disabled

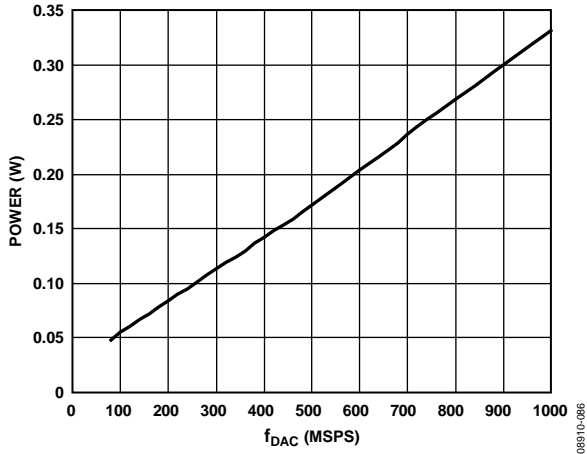

Figure 88. CVDD18 Power Dissipation vs.  $f_{DAC}$ , PLL Disabled

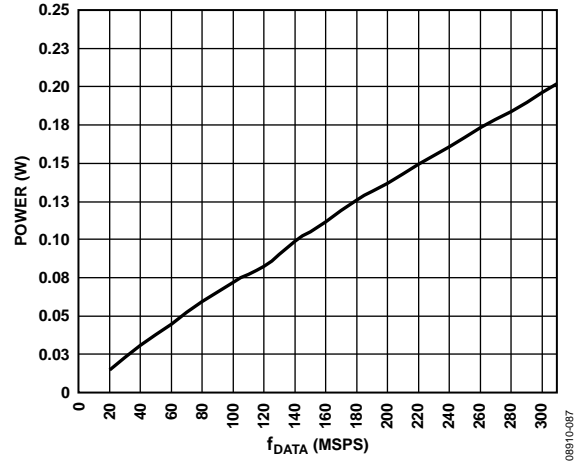

Figure 89. DVDD18 Power Dissipation vs.  $f_{DATA}$  Due to Inverse Sinc Filter

## TEMPERATURE SENSOR

The AD9148 has a diode-based temperature sensor for measuring the temperature of the die. The temperature reading is accessed by Register 0x5E and Register 0x5F. The temperature of the die can be calculated as

$$T_{DIE} = \frac{(DieTemp[15:0] - 13,700)}{130}$$

where  $T_{DIE}$  is the die temperature in degrees Celsius. The temperature accuracy is  $\pm 5^{\circ}\text{C}$  typical over the  $+85^{\circ}\text{C}$  to  $-35^{\circ}\text{C}$  range. A typical plot of the AD9148 die temperature vs. die temperature code readback is shown in Figure 90.

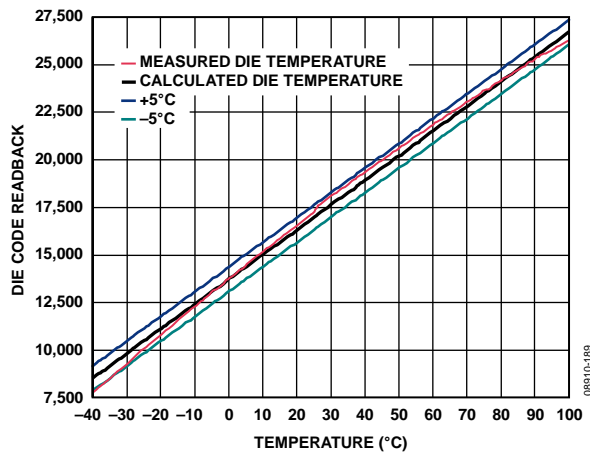

Figure 90. Die Temperature vs. Die Temperature Code Readback

Estimates of the ambient temperature can be made if the power dissipation of the device is known. For example, if the device power dissipation is 800 mW and the measured die temperature is  $50^{\circ}\text{C}$ , then the ambient temperature can be calculated as

$$T_A = T_{DIE} - P_D \times T_{JA} = 50 - 0.8 \times 18 = 35.6^{\circ}\text{C}$$

where:

$T_A$  is the ambient temperature in degrees Celsius.

$T_{JA}$  is the thermal resistance from junction to ambient of the AD9148 as shown in Table 7.

To use the temperature sensor, it must be enabled by setting Bit 0, Register 0x5C to 0. Before the temperature sensor data can be read back, it must be latched by toggling Bit 1, Register 0x5C from 0 to 1. In addition, to get accurate readings, the die temperature control register (Register 0x5D) should be set to 0x0A.

## INTERRUPT REQUEST OPERATION

The AD9148 provides an interrupt request output signal (Pin H4,  $\overline{\text{IRQ}}$ ) that can be used to notify an external host processor of significant device events. Upon assertion of the interrupt, the device should be queried to determine the precise event that occurred. The  $\overline{\text{IRQ}}$  pin is an open-drain, active low output.

Pull the  $\overline{\text{IRQ}}$  pin high external to the device. This pin may be tied to the interrupt pins of other devices with open-drain outputs to wired-OR these pins together.

Ten different event flags provide visibility into the device. These 10 flags are located in the two event flag registers (Register 0x06 and Register 0x07). The behavior of each of the event flags is independently selected in the interrupt enable registers (Register 0x04 and Register 0x05). When the flag interrupt enable is active, the event flag latches and triggers an external interrupt. When the flag interrupt is disabled, the event flag simply monitors the source signal, and the external  $\overline{\text{IRQ}}$  remains inactive.

Figure 91 shows the  $\overline{\text{IRQ}}$ -related circuitry. Figure 91 shows how the event flag signals propagate to the  $\overline{\text{IRQ}}$  output. The `interrupt_enable` signal represents one bit from the interrupt enable register. The `event_flag` signal represents one bit from the event flag register. The `event_flag_source` signal represents one of the device signals that can be monitored such as the `PLL_locked` signal from the PLL phase detector or the `FIFO Warning 1` signal from the FIFO controller.

When an interrupt enable bit is set high, the corresponding event flag bit reflects a positively tripped (that is, latched on the rising edge of the `event_flag_source` version of the `event_flag_source` signal). This signal also asserts the external  $\overline{\text{IRQ}}$ . When an interrupt enable bit is set low, the event flag bit reflects the current status of the

`event_flag_source` signal, and the event flag has no effect on the external  $\overline{\text{IRQ}}$ .

The latched version of an event flag (the `interrupt_source` signal) can be cleared in two ways. The recommended way is by writing 1 to the corresponding event flag bit. A hardware or software reset also clears the `interrupt_source`.

### INTERRUPT SERVICE ROUTINE

Interrupt request management starts by selecting the set of event flags that require host intervention or monitoring. Those events that require host action should be enabled so that the host is notified when they occur. For events requiring host intervention, upon  $\overline{\text{IRQ}}$  activation, run the following routine to clear an interrupt request:

- Read the status of the event flag bits that are being monitored.
- Set the interrupt enable bit low so that the unlatched `event_flag_source` can be monitored directly.
- Perform any actions that may be required to quiet the `event_source_flag`. In many cases, no specific actions may be required.
- Read the event flag to verify that the actions taken have quieted the `event_flag_source`.
- Clear the interrupt by writing 1 to the event flag bit.
- Set the interrupt enable bits of the events to be monitored.

Noted that some of the `event_flag_source` signals are latched signals. These are cleared by writing to the corresponding event flag bit. Details of each of the event flags can be found in Table 12.

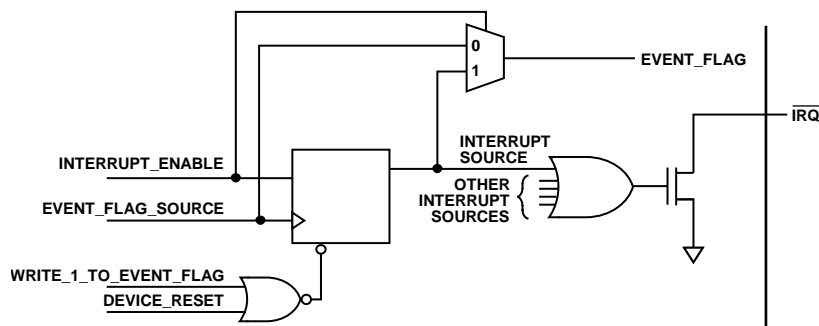

Figure 91. Simplified Schematic of  $\overline{\text{IRQ}}$  Circuitry

## INTERFACE TIMING VALIDATION

The AD9148 provides on-chip sample error detection (SED) circuitry that simplifies verification of the input data interface. The SED compares the input data samples captured at the digital input pins with a set of comparison values. The comparison values are loaded into registers through the SPI port. Differences between the captured values and the comparison values are detected and stored. Options are available for customizing SED test sequencing and error handling.

### SED OPERATION

The SED circuitry operates on two data sets, one for each data port, each made up of four 16-bit input words, denoted as S0, S1, S2, and S3. To properly align the input samples, the first data-word (that is, S0) is indicated by asserting FRAME for at least one complete input sample.

Figure 92 shows the input timing of the interface for each port. The FRAME signal can be issued once at the start of the data transmission, or it can be asserted repeatedly at intervals coinciding with the S0 and S1 data-words.

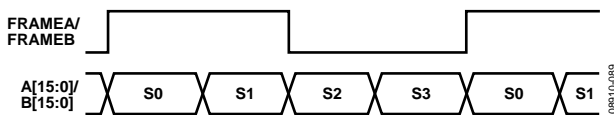

Figure 92. Timing Diagram of Extended FRAME Signal Required to Align Input Data for SED

The SED has five flag bits (Register 0x40, Bit 0, Bit 1, Bit 2, Bit 5 and Bit 6) that indicate the results of the input sample comparisons. The sample error detected bit (Bit 5, Register 0x40 for Port A and Bit 6, Register 0x40 for Port B) is set when an error is detected and remains set until cleared. The SED also provides registers that indicate which input data bits experienced errors (Register 0x41 through Register 0x44). These bits are latched and indicate the accumulated errors detected until cleared.

The autoclear mode has two effects: it activates the compare fail bits and the compare pass bit (Register 0x40, Bit 2, Bit 1, and Bit 0) and changes the behavior of Register 0x41 through Register 0x44. The compare pass bit sets if the last comparison indicated that the sample was error free. The compare fail bit sets if an error is detected. The compare fail bit is cleared automatically by the reception of eight consecutive error-free comparisons. When autoclear mode is enabled (Bit 3, Register 0x40), Register 0x41 through Register 0x44 accumulate errors as previously described but reset to all 0s after eight consecutive error-free sample comparisons are made.

The sample error, compare pass, and compare fail flags can be configured to trigger an  $\overline{\text{IRQ}}$  when active, if desired. This is done by enabling the appropriate bits in the event flag register (Register 0x07).

### SED EXAMPLE

#### Normal Operation

The following example illustrates the SED configuration for continuously monitoring the input data and assertion of an  $\overline{\text{IRQ}}$  when a single error is detected.

- Write to the following registers to enable the SED and load the comparison values:
  - Register 0x40  $\rightarrow$  0x80
  - Register 0x00[4]  $\rightarrow$  0 (to configure Port A SED)
  - Register 0x38  $\rightarrow$  S0[7:0]
  - Register 0x39  $\rightarrow$  S0[15:8]
  - Register 0x3A  $\rightarrow$  S1[7:0]
  - Register 0x3B  $\rightarrow$  S1[15:8]
  - Register 0x3C  $\rightarrow$  S2[7:0]
  - Register 0x3D  $\rightarrow$  S2[15:8]
  - Register 0x3E  $\rightarrow$  S3[7:0]
  - Register 0x3F  $\rightarrow$  S3[15:8]
  - Register 0x00[4]  $\rightarrow$  1 (to configure Port B SED)
  - Register 0x38  $\rightarrow$  S0[7:0]
  - Register 0x39  $\rightarrow$  S0[15:8]
  - Register 0x3A  $\rightarrow$  S1[7:0]
  - Register 0x3B  $\rightarrow$  S1[15:8]
  - Register 0x3C  $\rightarrow$  S2[7:0]
  - Register 0x3D  $\rightarrow$  S2[15:8]
  - Register 0x3E  $\rightarrow$  S3[7:0]
  - Register 0x3F  $\rightarrow$  S3[15:8]

Comparison values can be chosen arbitrarily; however, choosing values that require frequent bit toggling provides the most robust test.

- Enable the SED error detect flag to assert the  $\overline{\text{IRQ}}$  pin.  
Register 0x05  $\rightarrow$  0x04
- Begin transmitting the input data pattern.

If  $\overline{\text{IRQ}}$  is asserted, read Register 0x40 and Register 0x41 through Register 0x44 with Bit 4, Register 0x00 = 0 for Port A and with Bit 4, Register 0x00 = 1 for Port B, to verify that a SED error was detected, and determine which input bits were in error. The bits in Register 0x41 through Register 0x44 are latched; therefore, the bits indicate any errors that occurred on those bits throughout the test and not just the errors that caused the error detected flag to be set.

Note that the FRAME signal is not required during normal operation when the device is configured for dual-port mode. To enable the alignment of the S0 sample as previously described requires the use of both the FRAMEA and FRAMEB signals.

The timing diagrams for single-port and byte modes are the same as during normal operation and are shown in Figure 47 and Figure 48, respectively. For single-port and byte mode, only FRAMEA and the IRQs for Port A should be used. The FRAMEA rising edge should always be aligned with the first sample of the data transmission. There should not be another rising edge until four complete words of data are received. This means four data samples for dual-port mode and eight data samples for single-port and byte modes.

## EXAMPLE START-UP ROUTINE

To ensure reliable start-up of the AD9148, certain sequences should be followed. An example start-up routine using the following device configuration is used for this example.

- $f_{DATA} = 122.88$  MSPS
- Interpolation = 4×, using HB1 = '00' and HB2 = '000'
- Input data = baseband data
- Dual port mode with 1 DCI
- $f_{OUT} = 140$  MHz
- $f_{REFCLK} = 122.88$  MHz
- PLL = enabled
- Fine NCO = enabled
- Inverse sinc filter = disabled
- Synchronization = enabled

### DERIVED PLL SETTINGS

The following PLL settings can be derived from the device configuration:

- $f_{DACCLK} = f_{DATA} \times \text{Interpolation} = 491.52$  MHz
- $f_{VCO} = 4 \times f_{DACCLK} = 1966.08$  MHz ( $1 \text{ GHz} < f_{VCO} < 2 \text{ GHz}$ )
- $N1 = f_{DACCLK}/f_{REFCLK} = 4$
- $N0 = f_{VCO}/f_{DACCLK} = 4$

### DERIVED NCO SETTINGS

The following NCO settings can be derived from the device configuration:

- $f_{OUT} = 140$  MHz
- $f_{DACCLK} = f_{DATA} \times \text{Interpolation} = 491.52$  MHz
- $FTW = 140/(491.52) \times 2^{32} = 0x48, EAAAAA$

## START-UP SEQUENCE

The power clock and register write sequencing for reliable device start-up follows:

- Power up the device (no specific power supply sequence is required)
- Apply a stable REFCLK input signal.
- Apply a stable DCI input signal.
- Issue a hardware reset (optional)
- Configure device registers with the following write sequence:
  - 0x0C → 0xC9
  - 0x0D → 0xD9
  - 0x0A → 0xC0
  - 0x0A → 0x80
  - 0x10 → 0x48
  - 0x14 → 0x40
  - 0x17 → 0x08
  - 0x17 → 0x00
  - 0x19 → 0x08
  - 0x19 → 0x00
  - 0x1C → 0x40
  - 0x1D → 0x00
  - 0x1E → 0x01
  - 0x54 → 0xAA
  - 0x55 → 0xAA
  - 0x56 → 0xEA
  - 0x57 → 0x48
  - 0x5A → 0x01
  - 0x5A → 0x00

## DEVICE VERIFICATION SEQUENCE

The following device polling can be conducted to verify that the device is working properly:

- Read 0x06, Expect Bit 7 = 0, Bit 6 = 1, Bit 5 = 0, Bit 4 = 1, Bit 2 = 1
- Read 0x12, Expect Bit 6 = 1
- Read 0x18, Expect 0x0F (0x07 is also normal)
- Read 0x1A, Expect 0x0F (0x07 is also normal)

# OUTLINE DIMENSIONS

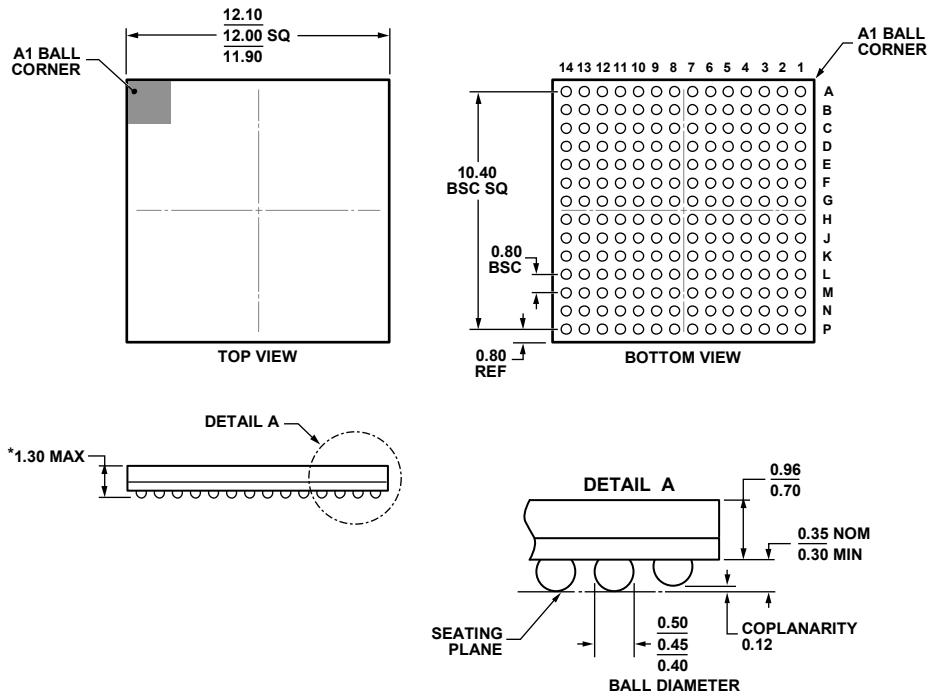

\*COMPLIANT TO JEDEC STANDARDS MO-275-GGAB-1 WITH EXCEPTION TO PACKAGE HEIGHT.

Figure 93. 196-Ball Chip Scale Package, Ball Grid Array [CSP\_BGA] BC-196-7

Dimensions shown in millimeters

11-18-2011-B

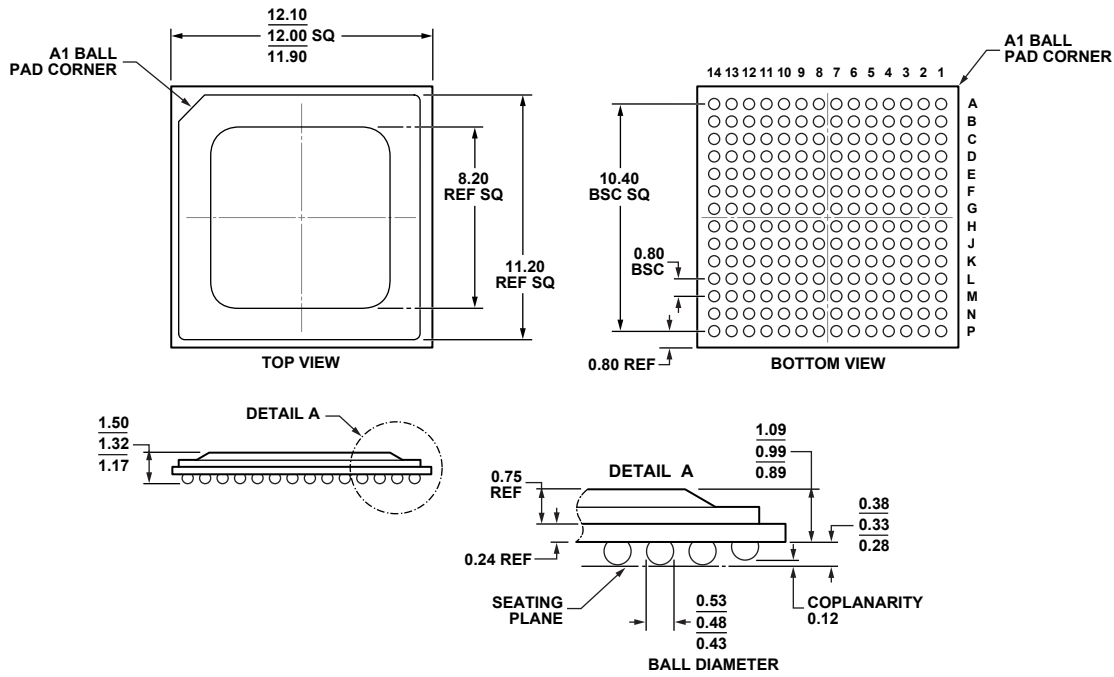

COMPLIANT TO JEDEC STANDARDS MO-192.

Figure 94. 196-Ball Ball Grid Array, Thermally Enhanced [BGA\_ED]  
BP-196-1  
Dimensions shown in millimeters

02-07-2013-A

**ORDERING GUIDE**

Model <sup>1</sup>	Temperature Range	Package Description	Package Option
AD9148BBCZ	-40°C to +85°C	196-Ball Chip Scale Package Ball Grid Array [CSP_BGA]	BC-196-7
AD9148BBCZRL	-40°C to +85°C	196-Ball Chip Scale Package Ball Grid Array [CSP_BGA]	BC-196-7
AD9148BBPZ	-40°C to +85°C	196-Ball Ball Grid Array, Thermally Enhanced [BGA_ED]	BP-196-1
AD9148BBPZRL	-40°C to +85°C	196-Ball Ball Grid Array, Thermally Enhanced [BGA_ED]	BP-196-1
AD9148-EBZ		DAC Only Evaluation Board [BGA_ED]	BP-196-1
AD9148-M5372-EBZ		AD9148 + ADL5372 Evaluation Board [BGA_ED]	BP-196-1
AD9148-M5375-EBZ		AD9148 + ADL5375-0.5 Evaluation Board [BGA_ED]	BP-196-1

<sup>1</sup> Z = RoHS Compliant Part.

**NOTES**

**NOTES**

## Looking for pricing, stock, or lifecycle information?

Click below to explore more details on WIN SOURCE:

 [View AD9148BBCZRL on WIN SOURCE](#)

 [Analog Devices Inc. Information](#)

## Optimize Your Supply Chain with WIN SOURCE Solutions

-  Global Sourcing Solution
-  Obsolete Management
-  Cost Control Management
-  Shortage Management
-  Alternative Solution
-  Excess Inventory Management