



**THE DATASHEET OF  
LT1206CR#PBF**



## FEATURES

- 250mA Minimum Output Drive Current
- 60MHz Bandwidth,  $A_V = 2$ ,  $R_L = 100\Omega$
- 900V/ $\mu$ s Slew Rate,  $A_V = 2$ ,  $R_L = 50\Omega$
- 0.02% Differential Gain,  $A_V = 2$ ,  $R_L = 30\Omega$
- 0.17° Differential Phase,  $A_V = 2$ ,  $R_L = 30\Omega$
- High Input Impedance, 10M $\Omega$
- Wide Supply Range,  $\pm 5V$  to  $\pm 15V$
- Shutdown Mode:  $I_S < 200\mu A$
- Adjustable Supply Current
- Stable with  $C_L = 10,000pF$
- Available in 8-Pin DIP and SO and 7-Pin DD and TO-220 Packages

## APPLICATIONS

- Video Amplifiers
- Cable Drivers
- RGB Amplifiers
- Test Equipment Amplifiers
- Buffers

## DESCRIPTION

The LT<sup>®</sup>1206 is a current feedback amplifier with high output current drive capability and excellent video characteristics. The LT1206 is stable with large capacitive loads, and can easily supply the large currents required by the capacitive loading. A shutdown feature switches the device into a high impedance, low current mode, reducing dissipation when the device is not in use. For lower bandwidth applications, the supply current can be reduced with a single external resistor. The low differential gain and phase, wide bandwidth, and the 250mA minimum output current drive make the LT1206 well suited to drive multiple cables in video systems.

The LT1206 is manufactured on Linear Technology's proprietary complementary bipolar process.

LT, LT, LTC, LTM, Linear Technology and the Linear logo are registered trademarks of Linear Technology Corporation. All other trademarks are the property of their respective owners.

## TYPICAL APPLICATION

Noninverting Amplifier with Shutdown

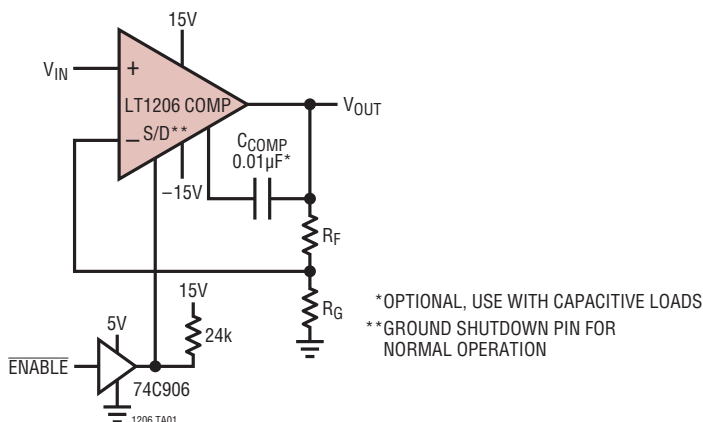

Large-Signal Response,  $C_L = 10,000pF$

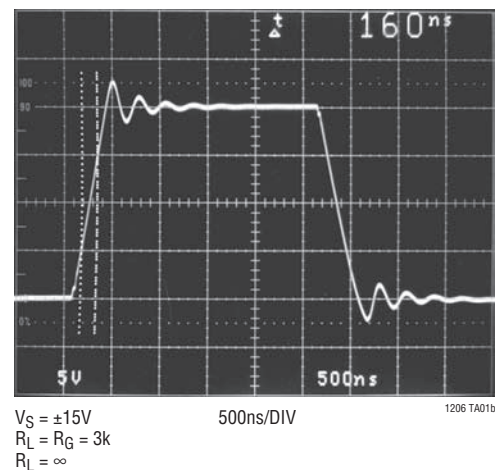

## ABSOLUTE MAXIMUM RATINGS (Note 1)

Supply Voltage .....	±18V	Operating Temperature Range .....	-40°C to 85°C
Input Current.....	±15mA	Junction Temperature .....	150°C
Output Short-Circuit Duration (Note 2) .....	Continuous	Storage Temperature Range .....	-65°C to 150°C
Specified Temperature Range (Note 3) .....	0°C to 70°C	Lead Temperature (Soldering, 10 sec).....	300°C

## PIN CONFIGURATION

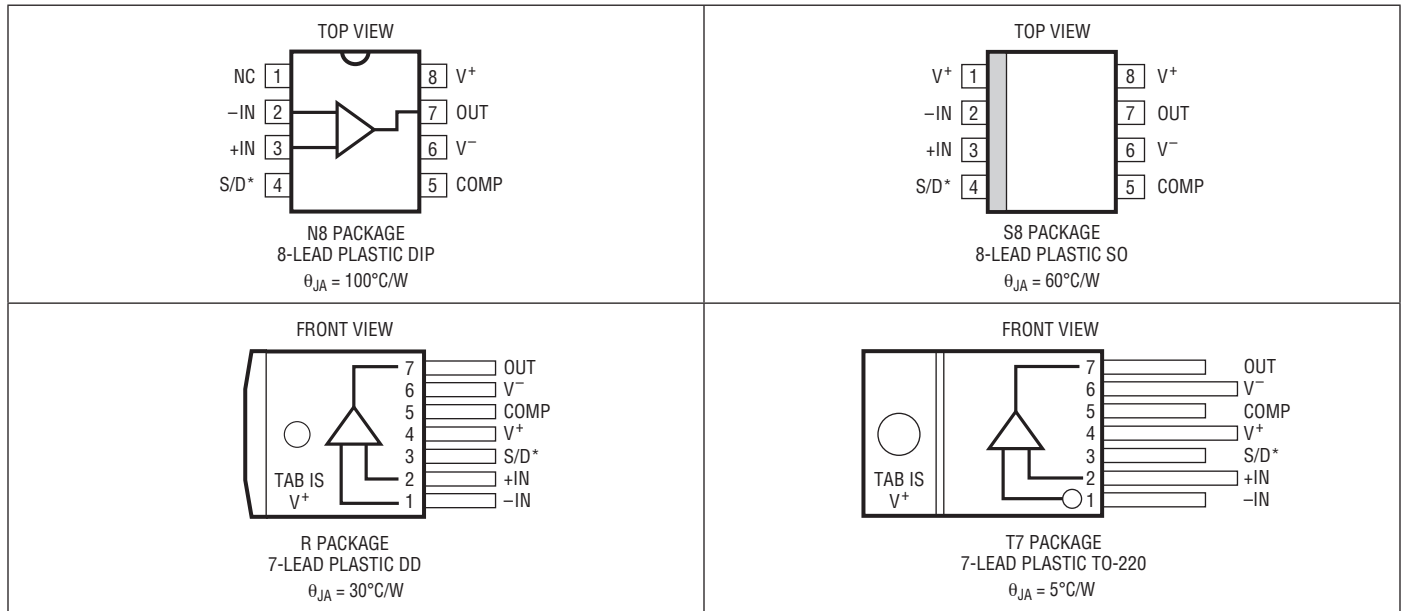

## ORDER INFORMATION

LEAD FREE FINISH	TAPE AND REEL	PART MARKING*	PACKAGE DESCRIPTION	TEMPERATURE RANGE
LTC1206CN8#PBF	LTC1206CN8#TRPBF	LT1206	8-Lead Plastic DIP	-40°C to 85°C
LT1206CS8#PBF	LT1206CS8#TRPBF	1206	8-Lead Plastic SO	-40°C to 85°C
LT1206CR#PBF	LT1206CR#TRPBF	LT1206	7-Lead Plastic DD	-40°C to 85°C
LT1206CT7#PBF	LT1206CT7#TRPBF	LT1206	7-Lead Plastic TO-220	-40°C to 85°C
LEAD BASED FINISH	TAPE AND REEL	PART MARKING*	PACKAGE DESCRIPTION	TEMPERATURE RANGE
LTC1206CN8†	LTC1206CN8#TR	LT1206	8-Lead Plastic DIP	-40°C to 85°C
LT1206CS8**	LT1206CS8#TR	1206	8-Lead Plastic SO	-40°C to 85°C
LT1206CR†	LT1206CR#TR	LT1206	7-Lead Plastic DD	-40°C to 85°C
LT1206CT7†	LT1206CT7#TR	LT1206	7-Lead Plastic TO-220	-40°C to 85°C

Consult LTC Marketing for parts specified with wider operating temperature ranges. \*The temperature grade is identified by a label on the shipping container. \*\*Ground shutdown pin for normal operation. †See Note 3.

For more information on lead free part marking, go to: <http://www.linear.com/leadfree/>  
 For more information on tape and reel specifications, go to: <http://www.linear.com/tapeandree/>

**ELECTRICAL CHARACTERISTICS** The ● denotes the specifications which apply over the full operating temperature range, otherwise specifications are at  $T_A = 25^\circ\text{C}$ ,  $V_{CM} = 0$ ,  $\pm 5\text{V} \leq V_S \leq 15\text{V}$ , pulse tested,  $V_{S/D} = 0\text{V}$ , unless otherwise noted.

SYMBOL	PARAMETER	CONDITIONS	MIN	TYP	MAX	UNITS	
$V_{OS}$	Input Offset Voltage		●	±3	±10	mV	
	Input Offset Voltage Drift		●	10	±15	μV/°C	
$I_{IN}^+$	Noninverting Input Current		●	±2	±8	μA	
$I_{IN}^-$	Inverting Input Current		●	±10	±60	μA	
$e_n$	Input Noise Voltage Density	$f = 10\text{kHz}$ , $R_F = 1\text{k}$ , $R_G = 10\Omega$ , $R_S = 0\Omega$		3.6		nV/√Hz	
$+i_n$	Input Noise Current Density	$f = 10\text{kHz}$ , $R_F = 1\text{k}$ , $R_G = 10\Omega$ , $R_S = 10\text{k}$		2		pA/√Hz	
$-i_n$	Input Noise Current Density	$f = 10\text{kHz}$ , $R_F = 1\text{k}$ , $R_G = 10\Omega$ , $R_S = 10\text{k}$		30		pA/√Hz	
$R_{IN}$	Input Resistance	$V_{IN} = \pm 12\text{V}$ , $V_S = \pm 15\text{V}$	●	1.5	10	MΩ	
		$V_{IN} = \pm 2\text{V}$ , $V_S = \pm 5\text{V}$	●	0.5	5	MΩ	
$C_{IN}$	Input Capacitance	$V_S = \pm 15\text{V}$		2		pF	
	Input Voltage Range	$V_S = \pm 15\text{V}$	●	±12	±13.5	V	
		$V_S = \pm 5\text{V}$	●	±2	±3.5	V	
CMRR	Common Mode Rejection Ratio	$V_S = \pm 15\text{V}$ , $V_{CM} = \pm 12\text{V}$	●	55	62	dB	
		$V_S = \pm 5\text{V}$ , $V_{CM} = \pm 2\text{V}$	●	50	60	dB	
	Inverting Input Current Common Mode Rejection	$V_S = \pm 15\text{V}$ , $V_{CM} = \pm 12\text{V}$	●	0.1	10	μA/V	
		$V_S = \pm 5\text{V}$ , $V_{CM} = \pm 2\text{V}$	●	0.1	10	μA/V	
PSRR	Power Supply Rejection Ratio	$V_S = \pm 5\text{V}$ to $\pm 15\text{V}$	●	60	77	dB	
	Noninverting Input Current Power Supply Rejection	$V_S = \pm 5\text{V}$ to $\pm 15\text{V}$	●	30	500	nA/V	
	Inverting Input Current Power Supply Rejection	$V_S = \pm 5\text{V}$ to $\pm 15\text{V}$	●	0.7	5	μA/V	
$A_V$	Large-Signal Voltage Gain	$V_S = \pm 15\text{V}$ , $V_{OUT} = \pm 10\text{V}$ , $R_L = 50\Omega$	●	55	71	dB	
		$V_S = \pm 5\text{V}$ , $V_{OUT} = \pm 2\text{V}$ , $R_L = 25\Omega$	●	55	68	dB	
$R_{OL}$	Transresistance, $\Delta V_{OUT}/\Delta I_{IN}^-$	$V_S = \pm 15\text{V}$ , $V_{OUT} = \pm 10\text{V}$ , $R_L = 50\Omega$	●	100	260	kΩ	
		$V_S = \pm 5\text{V}$ , $V_{OUT} = \pm 2\text{V}$ , $R_L = 25\Omega$	●	75	200	kΩ	
$V_{OUT}$	Maximum Output Voltage Swing	$V_S = \pm 15\text{V}$ , $R_L = 50\Omega$	●	±11.5	±12.5	V	
				±10.0		V	
		$V_S = \pm 15\text{V}$ , $R_L = 25\Omega$	●	±2.5	±3.0	V	
			●	±2.0		V	
$I_{OUT}$	Maximum Output Current	$R_L = 1\Omega$	●	250	500	1200	mA
$I_S$	Supply Current	$V_S = \pm 15\text{V}$ , $V_{S/D} = 0\text{V}$	●	20	30	35	mA
	Supply Current, $R_{S/D} = 51\text{k}$ (Note 4)	$V_S = \pm 15\text{V}$		12	17		mA
	Positive Supply Current, Shutdown	$V_S = \pm 15\text{V}$ , $V_{S/D} = 15\text{V}$	●		200		μA
	Output Leakage Current, Shutdown	$V_S = \pm 15\text{V}$ , $V_{S/D} = 15\text{V}$	●		10		μA
SR	Slew Rate (Note 5)	$A_V = 2$		400	900		V/μs
	Differential Gain (Note 6)	$V_S = \pm 15\text{V}$ , $R_F = 560\Omega$ , $R_G = 560\Omega$ , $R_L = 30\Omega$		0.02			%
	Differential Phase (Note 6)	$V_S = \pm 15\text{V}$ , $R_F = 560\Omega$ , $R_G = 560\Omega$ , $R_L = 30\Omega$		0.17			Deg
BW	Small-Signal Bandwidth	$V_S = \pm 15\text{V}$ , Peaking $\leq 0.5\text{dB}$ , $R_F = R_G = 620\Omega$ , $R_L = 100\Omega$		60			MHz
		$V_S = \pm 15\text{V}$ , Peaking $\leq 0.5\text{dB}$ , $R_F = R_G = 649\Omega$ , $R_L = 50\Omega$		52			MHz
		$V_S = \pm 15\text{V}$ , Peaking $\leq 0.5\text{dB}$ , $R_F = R_G = 698\Omega$ , $R_L = 30\Omega$		43			MHz
		$V_S = \pm 15\text{V}$ , Peaking $\leq 0.5\text{dB}$ , $R_F = R_G = 825\Omega$ , $R_L = 10\Omega$		27			MHz

**Note 1:** Stresses beyond those listed under Absolute Maximum Ratings may cause permanent damage to the device. Exposure to any Absolute Maximum Rating condition for extended periods may affect device reliability and lifetime.

**Note 2:** Applies to short circuits to ground only. A short circuit between the output and either supply may permanently damage the part when operated on supplies greater than  $\pm 10\text{V}$ .

**Note 3:** Commercial grade parts are designed to operate over the temperature range of  $-40^\circ\text{C}$  to  $85^\circ\text{C}$  but are neither tested nor guaranteed beyond  $0^\circ\text{C}$  to  $70^\circ\text{C}$ . Industrial grade parts tested over  $-40^\circ\text{C}$  to  $85^\circ\text{C}$  are available on special request. Consult factory.

**Note 4:**  $R_{S/D}$  is connected between the shutdown pin and ground.

**Note 5:** Slew rate is measured at  $\pm 5\text{V}$  on a  $\pm 10\text{V}$  output signal while operating on  $\pm 15\text{V}$  supplies with  $R_F = 1.5\text{k}$ ,  $R_G = 1.5\text{k}$  and  $R_L = 400\Omega$ .

**Note 6:** NTSC composite video with an output level of  $2\text{V}$ .

## SMALL-SIGNAL BANDWIDTH

$I_S = 20\text{mA}$  Typical, Peaking  $\leq 0.1\text{dB}$

$A_V$	$R_L$	$R_F$	$R_G$	-3dB BW (MHz)	-0.1dB BW (MHz)
$V_S = \pm 5\text{V}, R_{S/D} = 0\Omega$					
-1	150	562	562	48	21.4
	30	649	649	34	17
	10	732	732	22	12.5
1	150	619	-	54	22.3
	30	715	-	36	17.5
	10	806	-	22.4	11.5
2	150	576	576	48	20.7
	30	649	649	35	18.1
	10	750	750	22.4	11.7
10	150	442	48.7	40	19.2
	30	511	56.2	31	16.5
	10	649	71.5	20	10.2

$A_V$	$R_L$	$R_F$	$R_G$	-3dB BW (MHz)	-0.1dB BW (MHz)
$V_S = \pm 15\text{V}, R_{S/D} = 0\Omega$					
-1	150	681	681	50	19.2
	30	768	768	35	17
	10	887	887	24	12.3
1	150	768	-	66	22.4
	30	909	-	37	17.5
	10	1k	-	23	12
2	150	665	665	55	23
	30	787	787	36	18.5
	10	931	931	22.5	11.8
10	150	487	536	44	20.7
	30	590	64.9	33	17.5
	10	768	84.5	20.7	10.8

$I_S = 10\text{mA}$  Typical, Peaking  $\leq 0.1\text{dB}$

$A_V$	$R_L$	$R_F$	$R_G$	-3dB BW (MHz)	-0.1dB BW (MHz)
$V_S = \pm 5\text{V}, R_{S/D} = 10.2\text{k}$					
-1	150	576	576	35	17
	30	681	681	25	12.5
	10	750	750	16.4	8.7
1	150	665	-	37	17.5
	30	768	-	25	12.6
	10	845	-	16.5	8.2
2	150	590	590	35	16.8
	30	681	681	25	13.4
	10	768	768	16.2	8.1
10	150	301	33.2	31	15.6
	30	392	43.2	23	11.9
	10	499	54.9	15	7.8

$A_V$	$R_L$	$R_F$	$R_G$	-3dB BW (MHz)	-0.1dB BW (MHz)
$V_S = \pm 15\text{V}, R_{S/D} = 60.4\text{k}$					
-1	150	634	634	41	19.1
	30	768	768	26.5	14
	10	866	866	17	9.4
1	150	768	-	44	18.8
	30	909	-	28	14.4
	10	1k	-	16.8	8.3
2	150	649	649	40	18.5
	30	787	787	27	14.1
	10	931	931	16.5	8.1
10	150	301	33.2	33	15.6
	30	402	44.2	25	13.3
	10	590	64.9	15.3	7.4

$I_S = 5\text{mA}$  Typical, Peaking  $\leq 0.1\text{dB}$

$A_V$	$R_L$	$R_F$	$R_G$	-3dB BW (MHz)	-0.1dB BW (MHz)
$V_S = \pm 5\text{V}, R_{S/D} = 22.1\text{k}$					
-1	150	604	604	21	10.5
	30	715	715	14.6	7.4
	10	681	681	10.5	6.0
1	150	768	-	20	9.6
	30	866	-	14.1	6.7
	10	825	-	9.8	5.1
2	150	634	634	20	9.6
	30	750	750	14.1	7.2
	10	732	732	9.6	5.1
10	150	100	11.1	16.2	5.8
	30	100	11.1	13.4	7.0
	10	100	11.1	9.5	4.7

$A_V$	$R_L$	$R_F$	$R_G$	-3dB BW (MHz)	-0.1dB BW (MHz)
$V_S = \pm 15\text{V}, R_{S/D} = 121\text{k}$					
-1	150	619	619	25	12.5
	30	787	787	15.8	8.5
	10	825	825	10.5	5.4
1	150	845	-	23	10.6
	30	1k	-	15.3	7.6
	10	1k	-	10	5.2
2	150	681	681	23	10.2
	30	845	845	15	7.7
	10	866	866	10	5.4
10	150	100	11.1	15.9	4.5
	30	100	11.1	13.6	6
	10	100	11.1	9.6	4.5

# TYPICAL PERFORMANCE CHARACTERISTICS

**Bandwidth vs Supply Voltage**

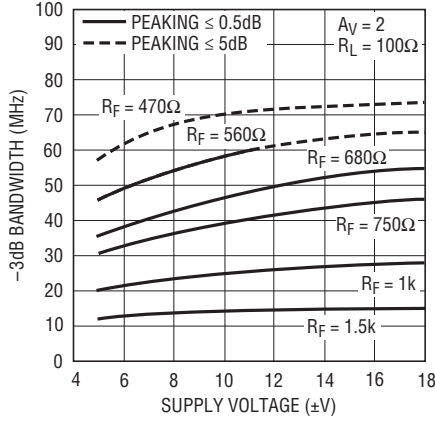

1206 G01

**Bandwidth vs Supply Voltage**

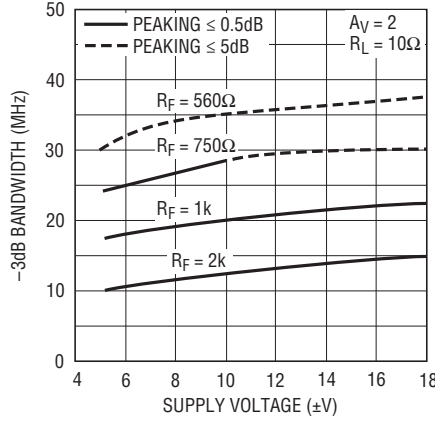

1206 G02

**Bandwidth and Feedback Resistance vs Capacitive Load for 0.5dB Peak**

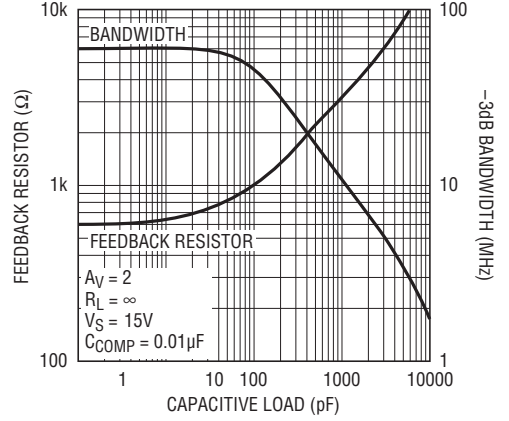

1206 G03

**Bandwidth vs Supply Voltage**

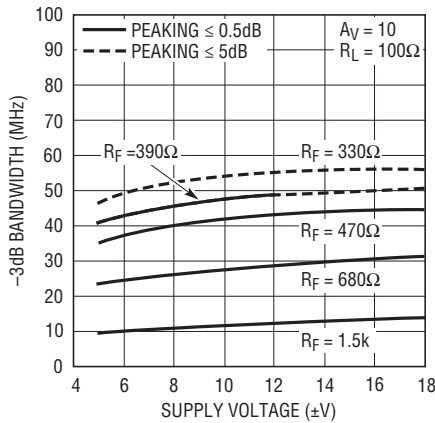

1206 G04

**Bandwidth vs Supply Voltage**

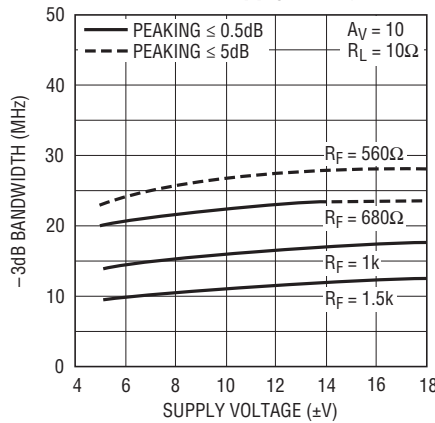

1206 G05

**Bandwidth and Feedback Resistance vs Capacitive Load for 5dB Peak**

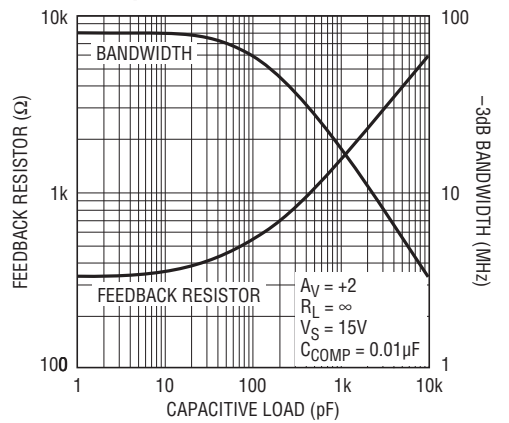

1206 G06

**Differential Phase vs Supply Voltage**

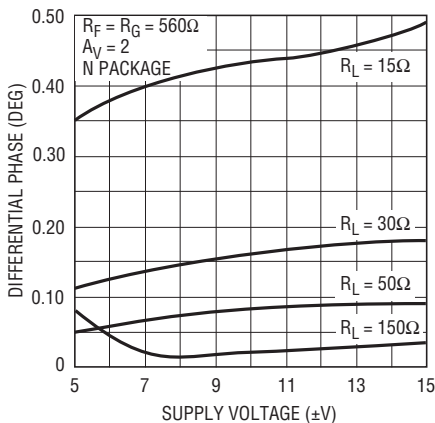

1206 G07

**Differential Gain vs Supply Voltage**

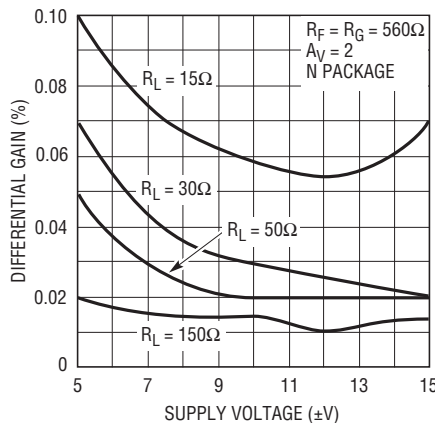

1206 G08

**Spot Noise Voltage and Current vs Frequency**

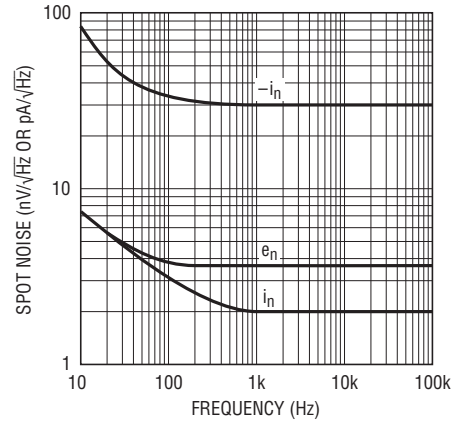

1206 G09

TYPICAL PERFORMANCE CHARACTERISTICS

Supply Current vs Supply Voltage

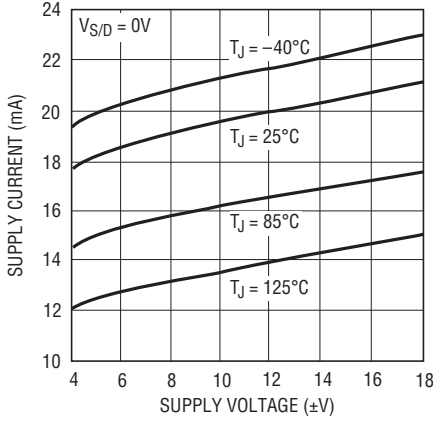

1206 G10

Supply Current vs Ambient Temperature,  $V_S = \pm 5V$

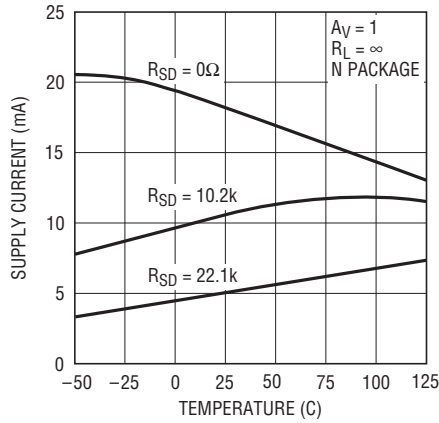

1206 G11

Supply Current vs Ambient Temperature,  $V_S = \pm 15V$

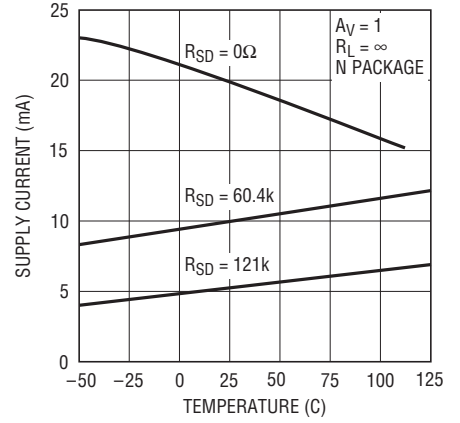

1206 G12

Supply Current vs Shutdown Pin Current

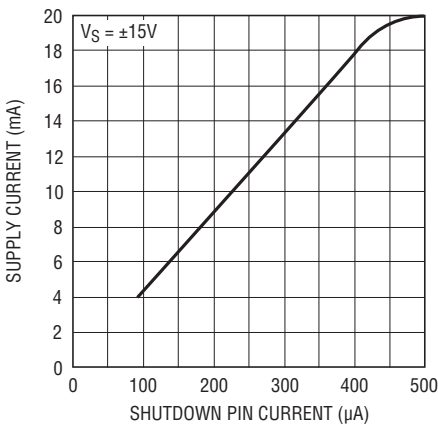

1206 G13

Input Common Mode Limit vs Junction Temperature

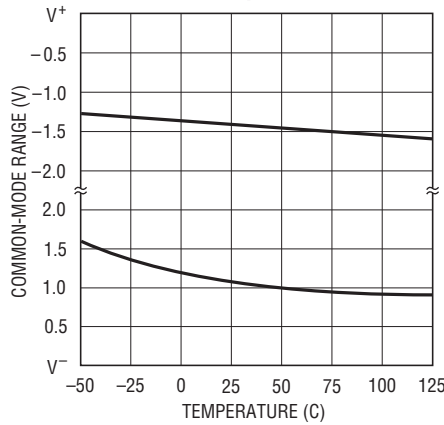

1206 G14

Output Short-Circuit Current vs Junction Temperature

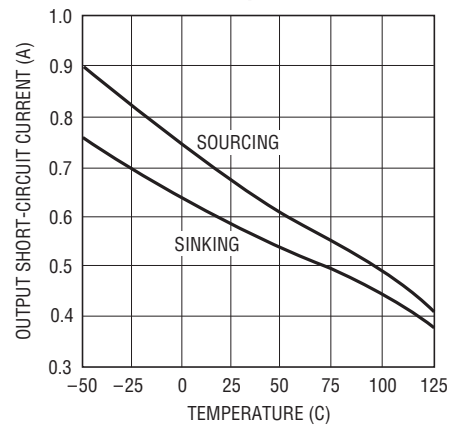

1206 G15

Output Saturation Voltage vs Junction Temperature

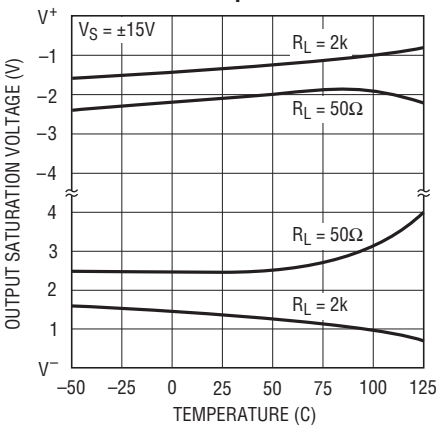

1206 G16

Power Supply Rejection Ratio vs Frequency

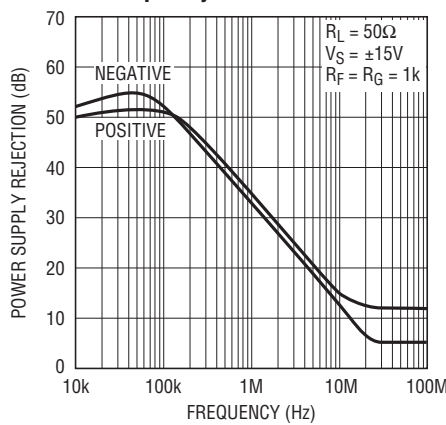

1206 G17

Supply Current vs Large-Signal Output Frequency (No Load)

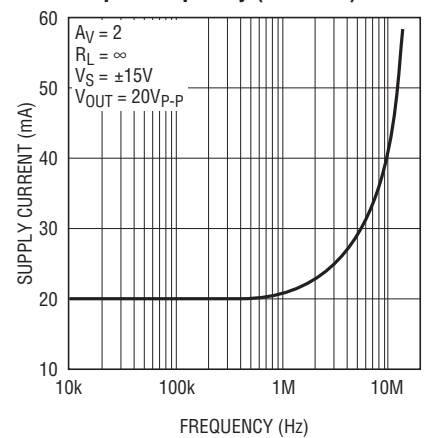

1206 G18

# TYPICAL PERFORMANCE CHARACTERISTICS

**Output Impedance vs Frequency**

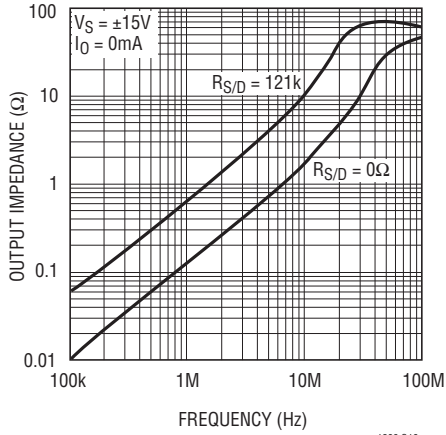

1206 G19

**Output Impedance in Shutdown vs Frequency**

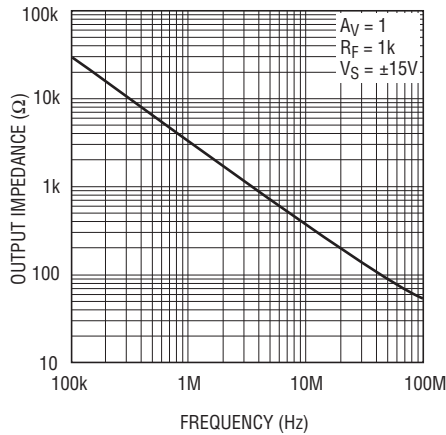

1206 G20

**2nd and 3rd Harmonic Distortion vs Frequency**

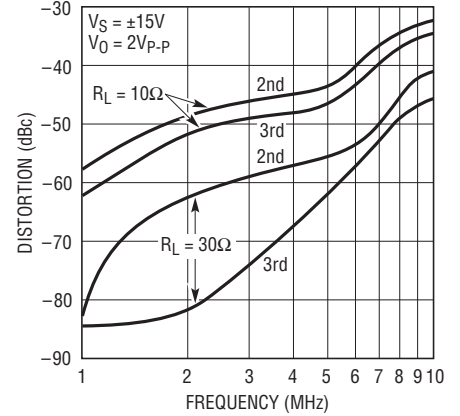

1206 G21

**3rd Order Intercept vs Frequency**

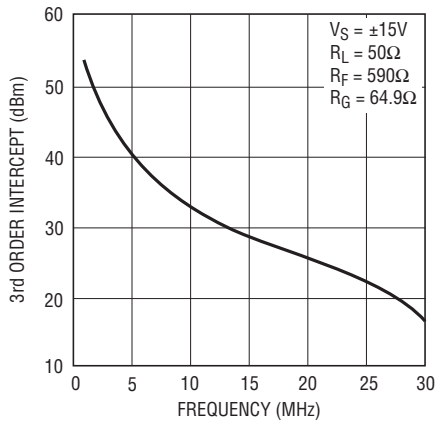

1206 G22

**Test Circuit for 3rd Order Intercept**

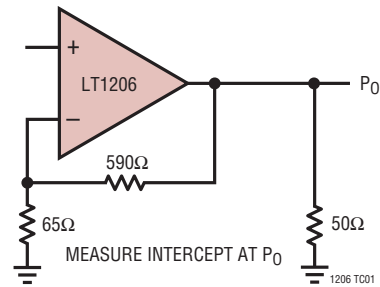

1206 TC01

**SIMPLIFIED SCHEMATIC**

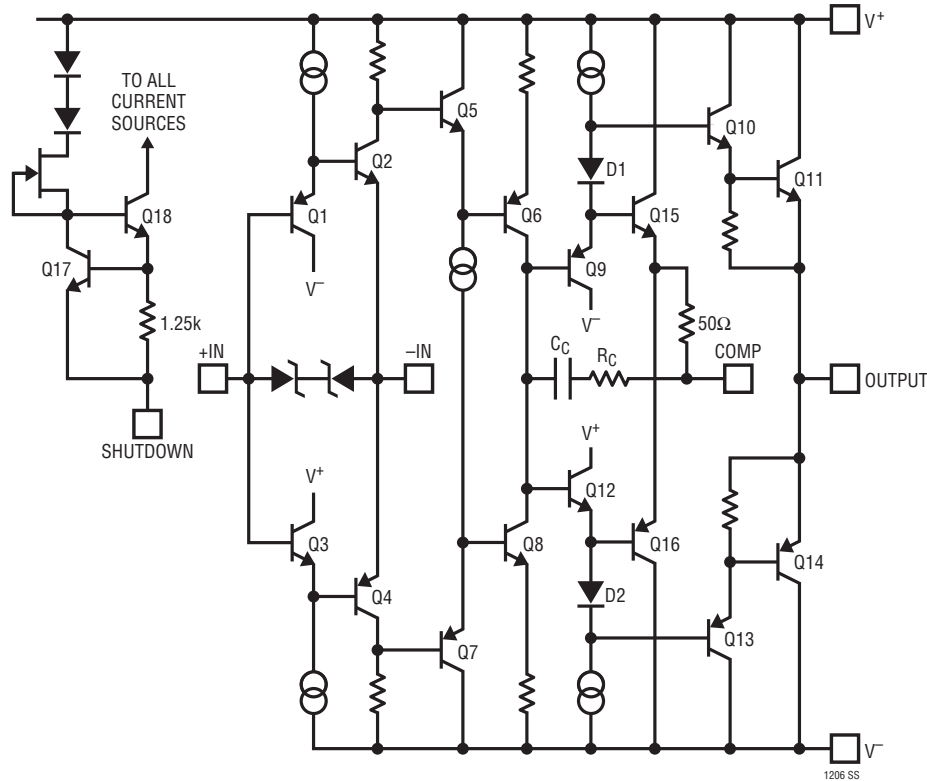

**APPLICATIONS INFORMATION**

The LT1206 is a current feedback amplifier with high output current drive capability. The device is stable with large capacitive loads and can easily supply the high currents required by capacitive loads. The amplifier will drive low impedance loads such as cables with excellent linearity at high frequencies.

**Feedback Resistor Selection**

The optimum value for the feedback resistors is a function of the operating conditions of the device, the load impedance and the desired flatness of response. The Typical AC Performance tables give the values which result in the highest 0.1dB and 0.5dB bandwidths for various resistive loads and operating conditions. If this level of flatness is not required, a higher bandwidth can be obtained by use of a lower feedback resistor. The characteristic curves of Bandwidth vs Supply Voltage indicate feedback resistors for peaking up to 5dB. These curves use a solid line when the response has less than 0.5dB of peaking and a dashed

line when the response has 0.5dB to 5dB of peaking. The curves stop where the response has more than 5dB of peaking.

For resistive loads, the COMP pin should be left open (see section on capacitive loads).

**Capacitive Loads**

The LT1206 includes an optional compensation network for driving capacitive loads. This network eliminates most of the output stage peaking associated with capacitive loads, allowing the frequency response to be flattened. Figure 1 shows the effect of the network on a 200pF load. Without the optional compensation, there is a 5dB peak at 40MHz caused by the effect of the capacitance on the output stage. Adding a 0.01μF bypass capacitor between the output and the COMP pins completely eliminates the peaking. A lower value feedback resistor can now be used, resulting in a response which

## APPLICATIONS INFORMATION

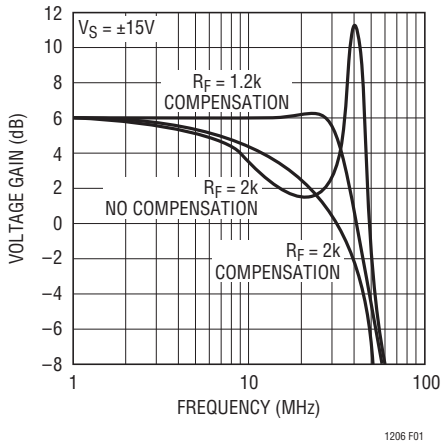

Figure 1

is flat to 0.35dB to 30MHz. The network has the greatest effect for  $C_L$  in the range of 0pF to 1000pF. The graph of Maximum Capacitive Load vs Feedback Resistor can be used to select the appropriate value of feedback resistor. The values shown are for 0.5dB and 5dB peaking at a gain of 2 with no resistive load. This is a worst case condition, as the amplifier is more stable at higher gains and with some resistive load in parallel with the capacitance. Also shown is the  $-3$ dB bandwidth with the suggested feedback resistor vs the load capacitance.

Although the optional compensation works well with capacitive loads, it simply reduces the bandwidth when it is connected with resistive loads. For instance, with a 30 $\Omega$  load, the bandwidth drops from 55MHz to 35MHz when the compensation is connected. Hence, the compensation was made optional. To disconnect the optional compensation, leave the COMP pin open.

### Shutdown/Current Set

**If the shutdown feature is not used, the SHUTDOWN pin must be connected to ground or  $V^-$ .**

The shutdown pin can be used to either turn off the biasing for the amplifier, reducing the quiescent current to less than 200 $\mu$ A, or to control the quiescent current in normal operation.

The total bias current in the LT1206 is controlled by the current flowing out of the shutdown pin. When the shutdown pin is open or driven to the positive supply, the part is shut down. In the shutdown mode, the output looks like a 40pF

capacitor and the supply current is typically 100 $\mu$ A. The shutdown pin is referenced to the positive supply through an internal bias circuit (see the simplified schematic). An easy way to force shutdown is to use open drain (collector) logic. The circuit shown in Figure 2 uses a 74C904 buffer to interface between 5V logic and the LT1206. The switching time between the active and shutdown states is less than 1 $\mu$ s. A 24k pull-up resistor speeds up the turn-off time and insures that the LT1206 is completely turned off. Because the pin is referenced to the positive supply, the logic used should have a breakdown voltage of greater than the positive supply voltage. No other circuitry is necessary as the internal circuit limits the shutdown pin current to about 500 $\mu$ A. Figure 3 shows the resulting waveforms.

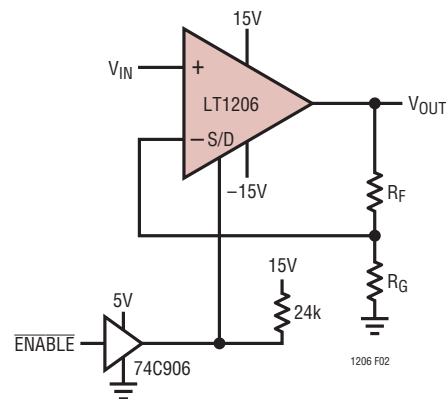
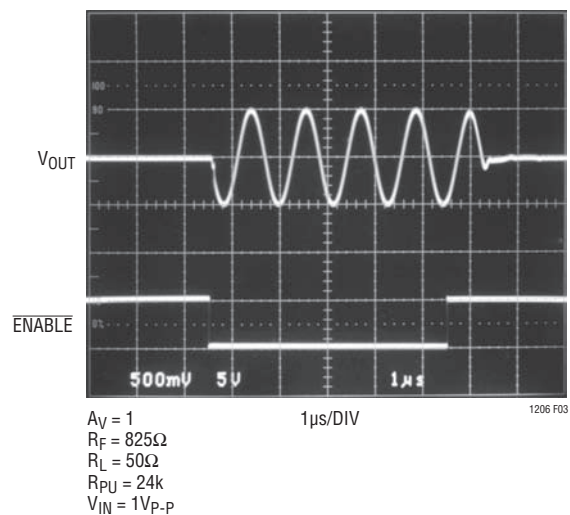

Figure 2. Shutdown Interface



$A_V = 1$   
 $R_F = 825\Omega$   
 $R_L = 50\Omega$   
 $R_{PU} = 24k$   
 $V_{IN} = 1V_{P-P}$

Figure 3. Shutdown Operation

## APPLICATIONS INFORMATION

For applications where the full bandwidth of the amplifier is not required, the quiescent current of the device may be reduced by connecting a resistor from the shutdown pin to ground. The quiescent current will be approximately 40 times the current in the shutdown pin. The voltage across the resistor in this condition is  $V^+ - 3V_{BE}$ . For example, a 60k resistor will set the quiescent supply current to 10mA with  $V_S = \pm 15V$ .

The photos (Figures 4a and 4b) show the effect of reducing the quiescent supply current on the large-signal response. The quiescent current can be reduced to 5mA in the inverting configuration without much change in response. In noninverting mode, however, the slew rate is reduced as the quiescent current is reduced.

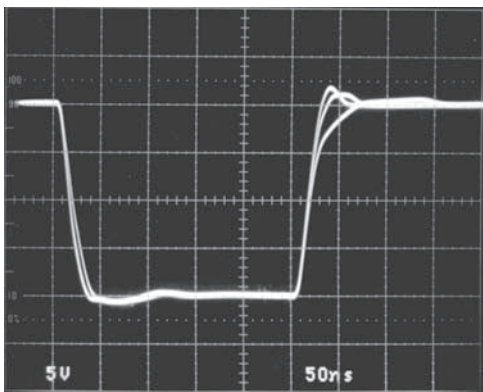

$R_F = 750\Omega$   
 $R_L = 50\Omega$   
 $I_Q = 5mA, 10mA, 20mA$   
 $V_S = \pm 15V$

Figure 4a. Large-Signal Response vs  $I_Q$ ,  $A_V = -1$

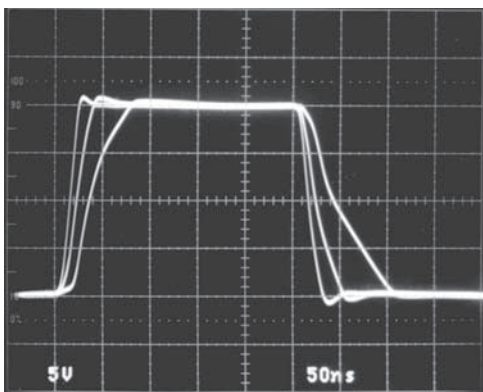

$R_F = 750\Omega$   
 $R_L = 50\Omega$   
 $I_Q = 5mA, 10mA, 20mA$   
 $V_S = \pm 15V$

Figure 4b. Large-Signal Response vs  $I_Q$ ,  $A_V = 2$

### Slew Rate

Unlike a traditional op amp, the slew rate of a current feedback amplifier is not independent of the amplifier gain configuration. There are slew rate limitations in both the input stage and the output stage. In the inverting mode, and for higher gains in the noninverting mode, the signal amplitude on the input pins is small and the overall slew rate is that of the output stage. The input stage slew rate is related to the quiescent current and will be reduced as the supply current is reduced. The output slew rate is set by the value of the feedback resistors and the internal capacitance. Larger feedback resistors will reduce the slew rate as will lower supply voltages, similar to the way the bandwidth is reduced. The photos (Figures 5a, 5b and 5c) show the large-signal response of the LT1206 for various gain configurations. The slew rate varies from 860V/ $\mu s$  for a gain of 1, to 1400V/ $\mu s$  for a gain of  $-1$ .

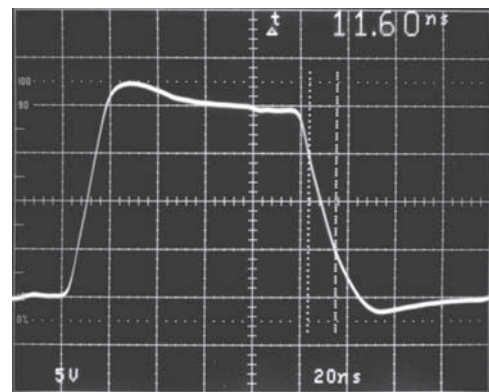

$R_F = 825\Omega$   
 $R_L = 50\Omega$   
 $V_S = \pm 15V$

Figure 5a. Large-Signal Response,  $A_V = 1$

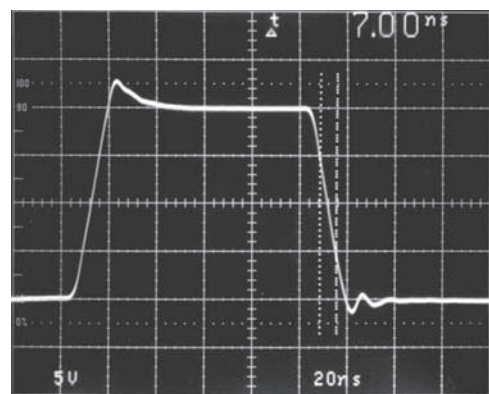

$R_F = R_G = 750\Omega$   
 $R_L = 50\Omega$   
 $V_S = \pm 15V$

Figure 5b. Large-Signal Response,  $A_V = -1$

1206fb

## APPLICATIONS INFORMATION

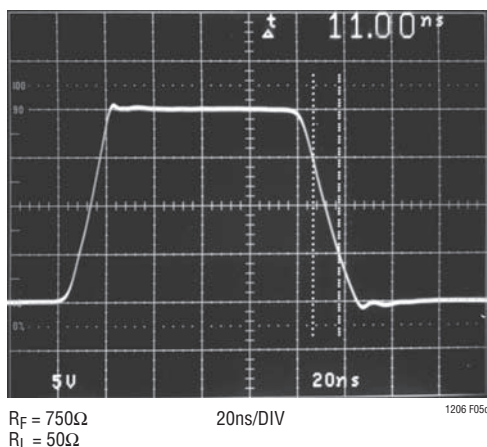

Figure 5c. Large-Signal Response,  $A_V = 2$

When the LT1206 is used to drive capacitive loads, the available output current can limit the overall slew rate. In the fastest configuration, the LT1206 is capable of a slew rate of over 1V/ns. The current required to slew a capacitor at this rate is 1mA per picofarad of capacitance, so 10,000pF would require 10A! The photo (Figure 6) shows the large signal behavior with  $C_L = 10,000\text{pF}$ . The slew rate is about 60V/ $\mu\text{s}$ , determined by the current limit of 600mA.

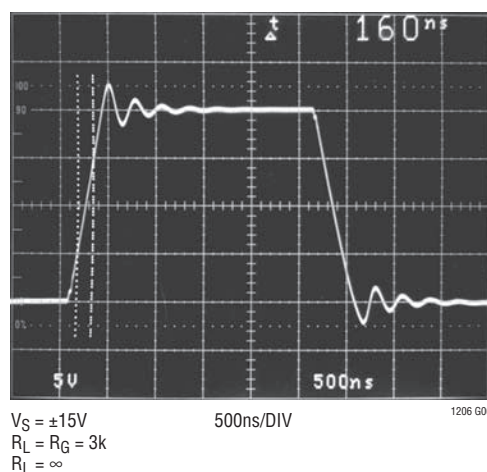

Figure 6. Large-Signal Response,  $C_L = 10,000\text{pF}$

### Differential Input Signal Swing

The differential input swing is limited to about  $\pm 6\text{V}$  by an ESD protection device connected between the inputs. In normal operation, the differential voltage between the input pins is small, so this clamp has no effect; however, in the shutdown mode the differential swing can be the same as the input swing. The clamp voltage will then set

the maximum allowable input voltage. To allow for some margin, it is recommended that the input signal be less than  $\pm 5\text{V}$  when the device is shut down.

### Capacitance on the Inverting Input

Current feedback amplifiers require resistive feedback from the output to the inverting input for stable operation. Take care to minimize the stray capacitance between the output and the inverting input. Capacitance on the inverting input to ground will cause peaking in the frequency response (and overshoot in the transient response), but it does not degrade the stability of the amplifier.

### Power Supplies

The LT1206 will operate from single or split supplies from  $\pm 5\text{V}$  (10V total) to  $\pm 15\text{V}$  (30V total). It is not necessary to use equal value split supplies, however the offset voltage and inverting input bias current will change. The offset voltage changes about  $500\mu\text{V}$  per volt of supply mismatch. The inverting bias current can change as much as  $5\mu\text{A}$  per volt of supply mismatch, though typically the change is less than  $0.5\mu\text{A}$  per volt.

### Thermal Considerations

The LT1206 contains a thermal shutdown feature which protects against excessive internal (junction) temperature. If the junction temperature of the device exceeds the protection threshold, the device will begin cycling between normal operation and an off state. The cycling is not harmful to the part. The thermal cycling occurs at a slow rate, typically 10ms to several seconds, which depends on the power dissipation and the thermal time constants of the package and heat sinking. Raising the ambient temperature until the device begins thermal shutdown gives a good indication of how much margin there is in the thermal design.

For surface mount devices heat sinking is accomplished by using the heat spreading capabilities of the PC board and its copper traces. Experiments have shown that the heat spreading copper layer does not need to be electrically connected to the tab of the device. The PCB material can be very effective at transmitting heat between the pad area attached to the tab of the device, and a ground or

## APPLICATIONS INFORMATION

power plane layer either inside or on the opposite side of the board. Although the actual thermal resistance of the PCB material is high, the length/area ratio of the thermal resistance between the layer is small. Copper board stiffeners and plated through holes can also be used to spread the heat generated by the device.

Tables 1 and 2 list thermal resistance for each package. For the TO-220 package, thermal resistance is given for junction-to-case only since this package is usually mounted to a heat sink. Measured values of thermal resistance for several different board sizes and copper areas are listed for each surface mount package. All measurements were taken in still air on 3/32" FR-4 board with 1oz copper. This data can be used as a rough guideline in estimating thermal resistance. The thermal resistance for each application will be affected by thermal interactions with other components as well as board size and shape.

**Table 1. R Package, 7-Lead DD**

COPPER AREA		BOARD AREA	THERMAL RESISTANCE (JUNCTION-TO-AMBIENT)
TOPSIDE*	BACKSIDE		
2500 sq. mm	2500 sq. mm	2500 sq. mm	25°C/W
1000 sq. mm	2500 sq. mm	2500 sq. mm	27°C/W
125 sq. mm	2500 sq. mm	2500 sq. mm	35°C/W

\*Tab of device attached to topside copper.

**Table 2. S8 Package, 8-Lead Plastic SO**

COPPER AREA		BOARD AREA	THERMAL RESISTANCE (JUNCTION-TO-AMBIENT)
TOPSIDE*	BACKSIDE		
2500 sq. mm	2500 sq. mm	2500 sq. mm	60°C/W
1000 sq. mm	2500 sq. mm	2500 sq. mm	62°C/W
225 sq. mm	2500 sq. mm	2500 sq. mm	65°C/W
100 sq. mm	2500 sq. mm	2500 sq. mm	69°C/W
100 sq. mm	1000 sq. mm	2500 sq. mm	73°C/W
100 sq. mm	225 sq. mm	2500 sq. mm	80°C/W
100 sq. mm	100 sq. mm	2500 sq. mm	83°C/W

\*Pins 1 and 8 attached to topside copper.

**Y Package, 7-Lead TO-220**

Thermal Resistance (Junction-to-Case) = 5°C/W

**N8 Package, 8-Lead DIP**

Thermal Resistance (Junction-to-Ambient) = 100°C/W

### Calculating Junction Temperature

The junction temperature can be calculated from the equation:

$$T_J = (P_D \times \theta_{JA}) + T_A$$

where:

$T_J$  = Junction Temperature

$T_A$  = Ambient Temperature

$P_D$  = Device Dissipation

$\theta_{JA}$  = Thermal Resistance (Junction-to Ambient)

As an example, calculate the junction temperature for the circuit in Figure 7 for the N8, S8, and R packages assuming a 70°C ambient temperature.

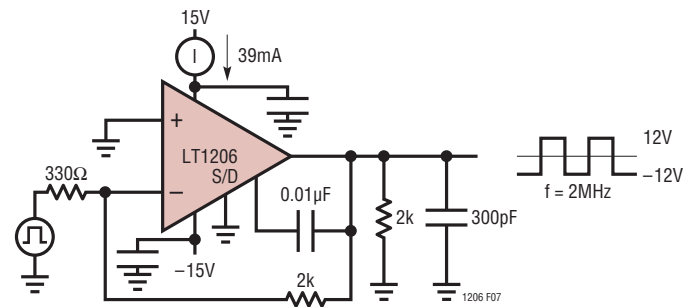

**Figure 7. Thermal Calculation Example**

The device dissipation can be found by measuring the supply currents, calculating the total dissipation, and then subtracting the dissipation in the load and feedback network.

$$P_D = (39\text{mA} \times 30\text{V}) - (12\text{V})^2 / (2\text{k}\Omega || 2\text{k}\Omega) = 1.03\text{W}$$

Then:

$$T_J = (1.03\text{W} \times 100^\circ\text{C/W}) + 70^\circ\text{C} = 173^\circ\text{C}$$

for the N8 package.

$$T_J = (1.03\text{W} \times 65^\circ\text{C/W}) + 70^\circ\text{C} = 137^\circ\text{C}$$

for the S8 with 225 sq. mm topside heat sinking.

$$T_J = (1.03\text{W} \times 35^\circ\text{C/W}) + 70^\circ\text{C} = 106^\circ\text{C}$$

for the R package with 100 sq. mm topside heat sinking.

Since the maximum junction temperature is 150°C, the N8 package is clearly unacceptable. Both the S8 and R packages are usable.

# APPLICATIONS INFORMATION

**Precision  $\times 10$  Hi Current Amplifier**

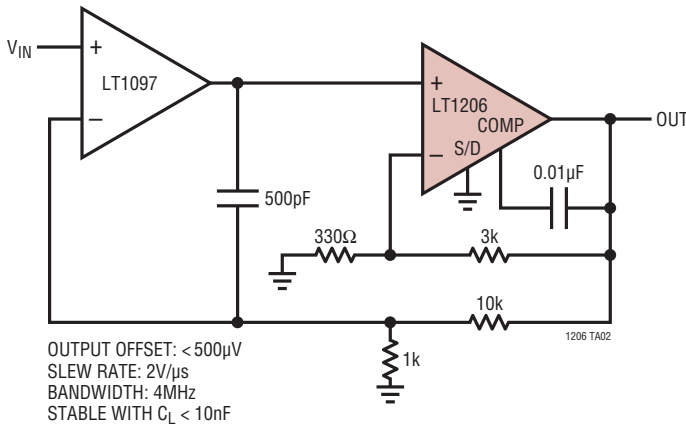

**CMOS Logic to Shutdown Interface**

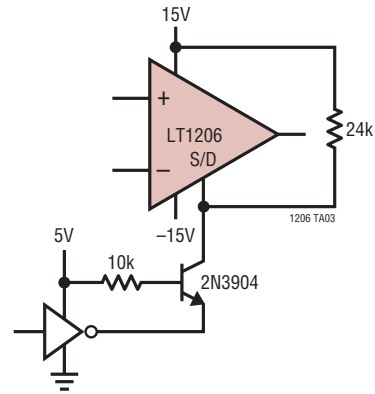

**Low Noise  $\times 10$  Buffered Line Driver**

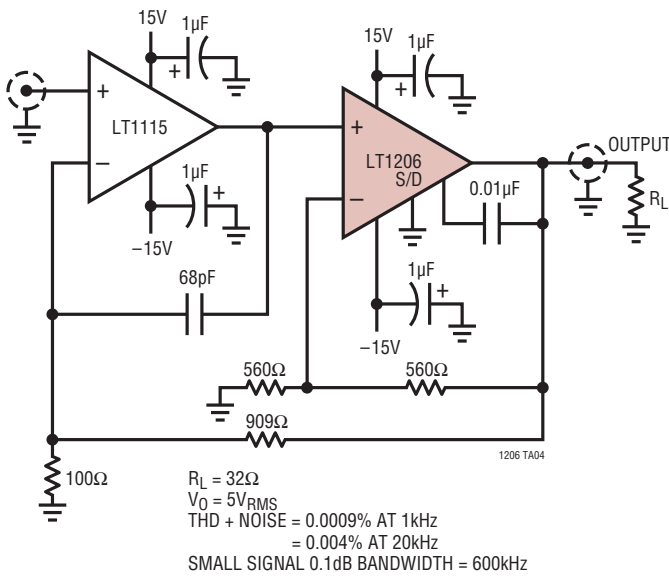

**Distribution Amplifier**

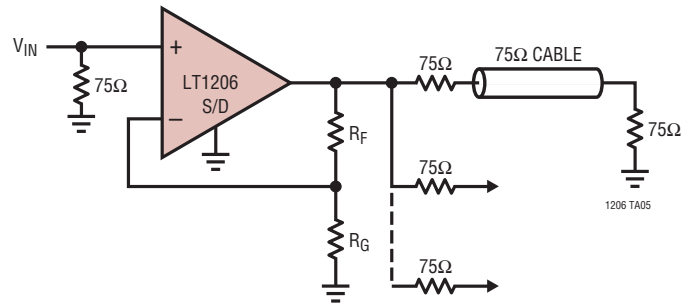

**Buffer  $A_V = 1$**

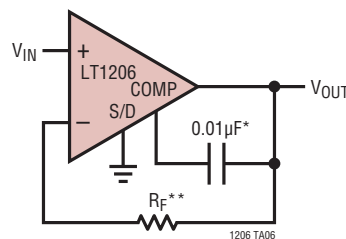

\*OPTIONAL, USE WITH CAPACITIVE LOADS  
 \*\*VALUE OF  $R_F$  DEPENDS ON SUPPLY VOLTAGE AND LOADING. SELECT FROM TYPICAL AC PERFORMANCE TABLE OR DETERMINE EMPIRICALLY

**PACKAGE DESCRIPTION**

**N8 Package**  
**8-Lead PDIP (Narrow .300 Inch)**  
 (Reference LTC DWG # 05-08-1510)

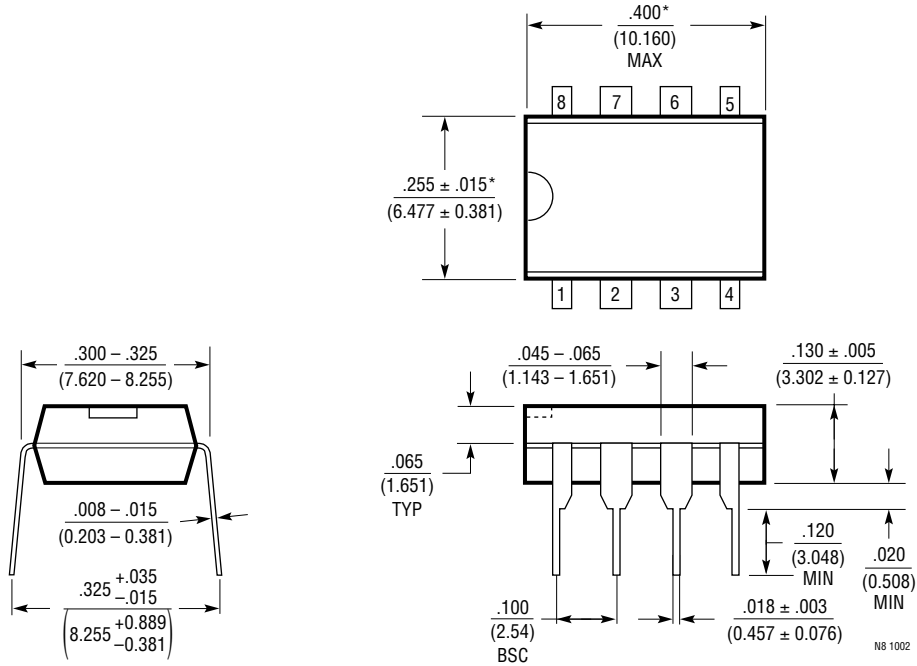

NOTE:  
 1. DIMENSIONS ARE  $\frac{\text{INCHES}}{\text{MILLIMETERS}}$   
 \*THESE DIMENSIONS DO NOT INCLUDE MOLD FLASH OR PROTRUSIONS.  
 MOLD FLASH OR PROTRUSIONS SHALL NOT EXCEED .010 INCH (0.254mm)

N8 1002

# PACKAGE DESCRIPTION

## R Package 7-Lead Plastic DD Pak (Reference LTC DWG # 05-08-1462 Rev E)

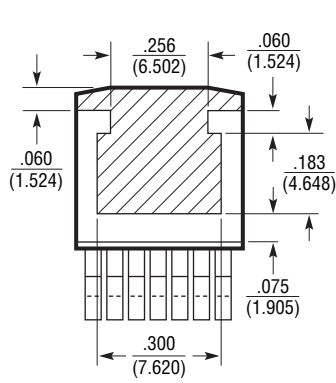

BOTTOM VIEW OF DD PAK  
HATCHED AREA IS SOLDER PLATED  
COPPER HEAT SINK

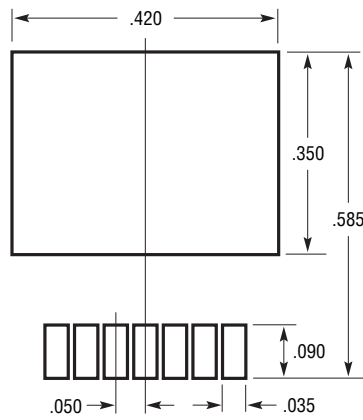
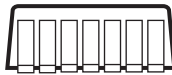
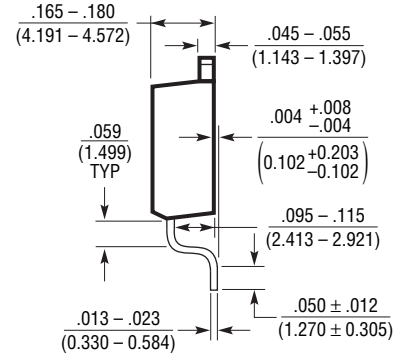
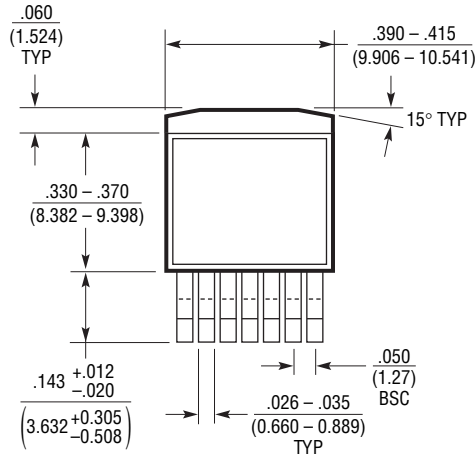

RECOMMENDED SOLDER PAD LAYOUT

NOTE:

1. DIMENSIONS IN INCH/(MILLIMETER)
2. DRAWING NOT TO SCALE

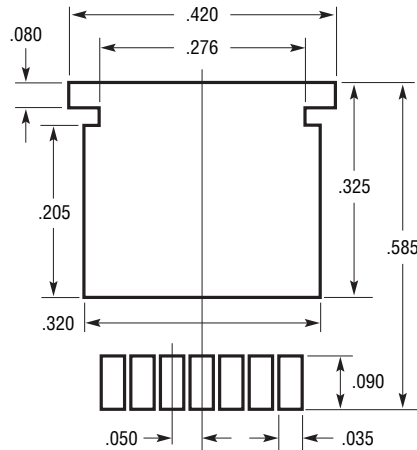

RECOMMENDED SOLDER PAD LAYOUT  
FOR THICKER SOLDER PASTE APPLICATIONS  
R (DD7) 0710 REV E

**PACKAGE DESCRIPTION**

**S8 Package**  
**8-Lead Plastic Small Outline (Narrow .150 Inch)**  
 (Reference LTC DWG # 05-08-1610)

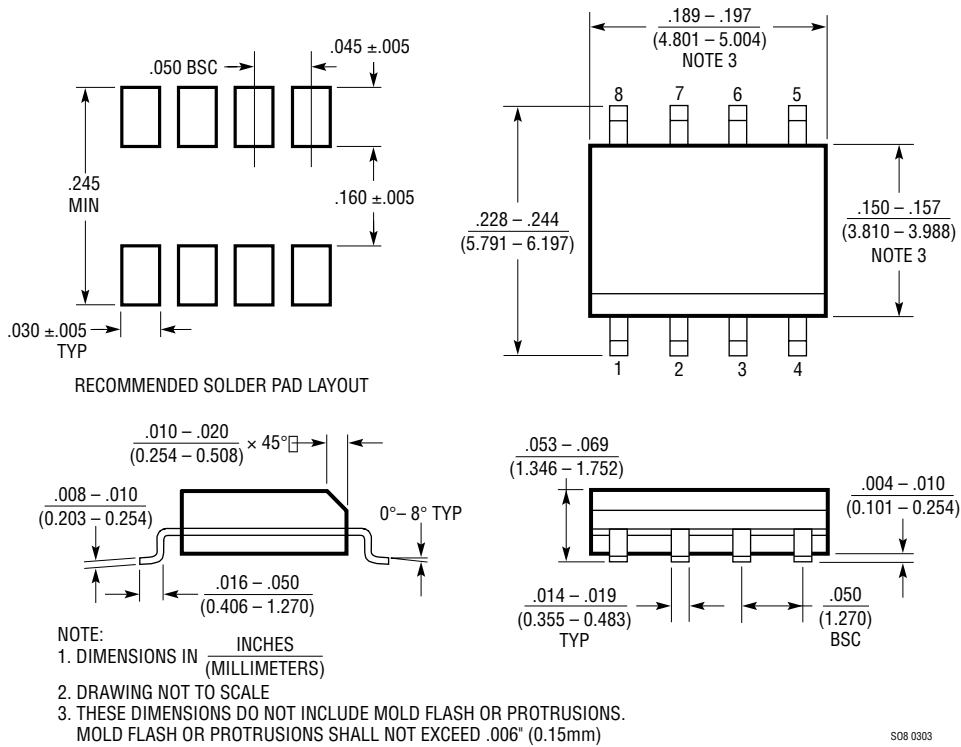

**T7 Package**  
**7-Lead Plastic TO-220 (Standard)**  
 (Reference LTC DWG # 05-08-1422)

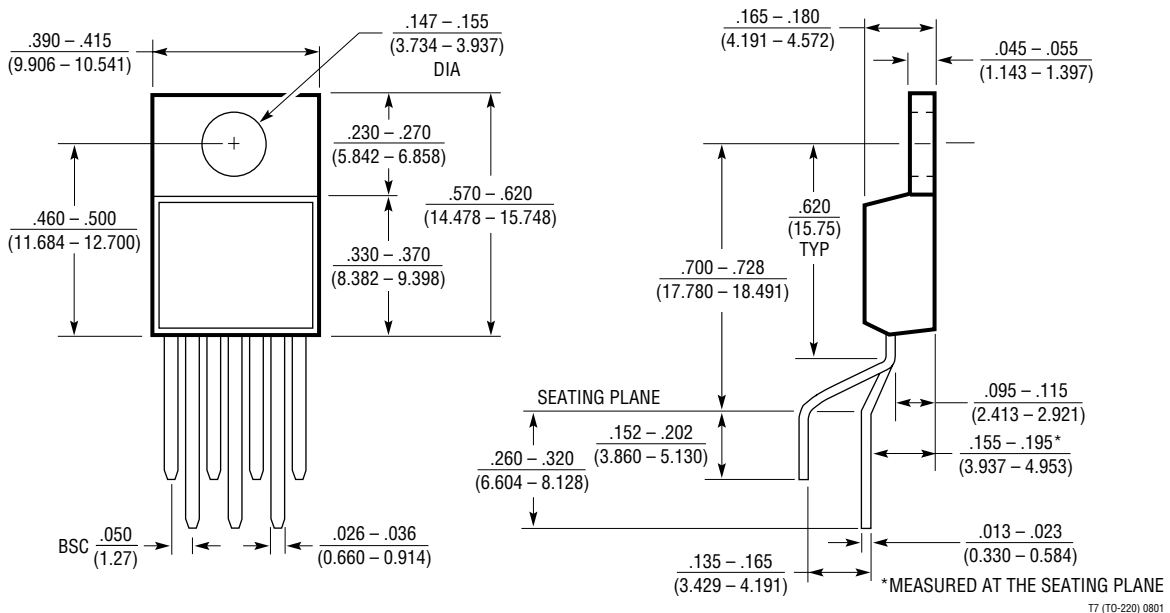

**REVISION HISTORY** (Revision history begins at Rev B)

REV	DATE	DESCRIPTION	PAGE NUMBER
B	3/11	Updated note on Table 2 in the Applications Information section.	12

## RELATED PARTS

PART NUMBER	DESCRIPTION	COMMENTS
LT1010	High Speed Buffer	High Power, High Speed Buffer
LT1207	Dual 250mA Out, 900V/ $\mu$ s, 60MHz Current Feedback Amplifier	Adjustable Supply Current, Shutdown
LT1210	1.1A, 35MHz, 900V/ $\mu$ s Current Feedback Amplifier	Adjustable Supply Current, Shutdown
LT1395	Single 400MHz Current Feedback Amplifier	0.1dB Gain Flatness to 100MHz
LT1815	6.5mA, 220MHz, 1.5V/ns Operational Amplifier with Programmable Current	S6 Version Features Programmable Supply Current
LT1818	400MHz, 2500V/ $\mu$ s, 9mA Single Operational Amplifier	High Speed, Low Noise, Low Distortion, Low Offset

## Looking for pricing, stock, or lifecycle information?

Click below to explore more details on WIN SOURCE:

 [View LT1206CR#PBF on WIN SOURCE](#)

 [Linear Technology](#) Information

## Optimize Your Supply Chain with WIN SOURCE Solutions

-  Global Sourcing Solution
-  Obsolete Management
-  Cost Control Management
-  Shortage Management
-  Alternative Solution
-  Excess Inventory Management