



**THE DATASHEET OF
UCC3974PWR**



DUAL COLD CATHODE FLUORESCENT LAMP CONTROLLER

FEATURES

- Synchronous or Nonsynchronous Operation
- Dual Output and Control Stages
- BiCMOS Technology
- Accurate Current Control with 2-mA Typical Supply Current
- Analog or Digital Low-Frequency Dimming Capability
- Open Lamp Protection with Voltage Clamp
- 4.5-V to 25-V Operation
- PWM Frequencies Synchronized to External Resonant Tanks
- TSSOP-16 (PW) Package

APPLICATIONS

- Portable PCs
- Desktop LCD Monitors
- Internet Appliances

DESCRIPTION

Design goals for a cold cathode fluorescent lamp (CCFL) converter used for a liquid crystal display (LCD) monitor application include small size, high efficiency, and low cost. The UCC2974/UCC3974 CCFL controllers provide the necessary circuit blocks to implement a highly efficient LCD monitor backlight supply in a small 16-pin TSSOP package. The device features two control stages for operating independent resonant tanks for multi-lamp designs. The BiCMOS controller typically consumes less than 2-mA of operating current, improving overall system efficiency. External parts count is minimized and system cost is reduced by integrating such features as dual PWM driver stages, open lamp protection, overvoltage clamp, and synchronization circuitry between the buck and push-pull stages. The device operates in both analog and low-frequency dimming modes.

TYPICAL APPLICATION

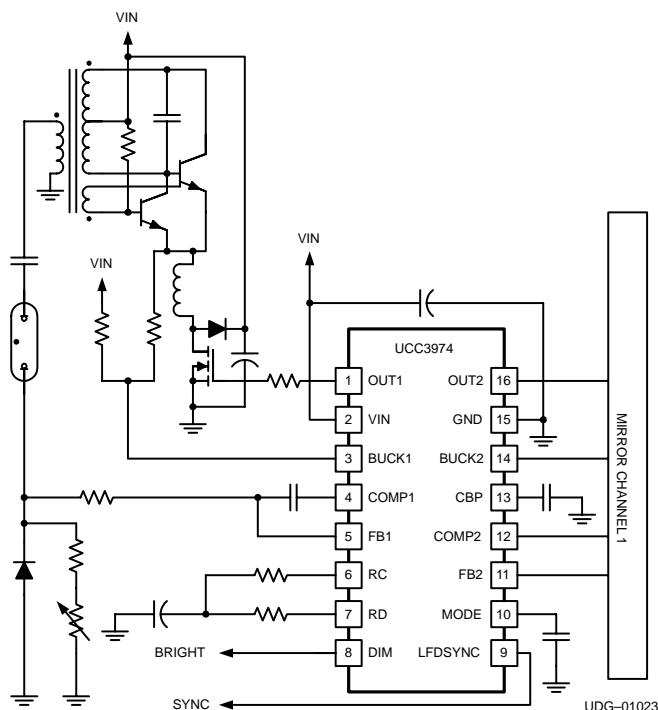

Please be aware that an important notice concerning availability, standard warranty, and use in critical applications of Texas Instruments semiconductor products and disclaimers thereto appears at the end of this data sheet.

UCC2974 UCC3974

SLUS485A – JULY 2001 – REVISED NOVEMBER 2001

absolute maximum ratings over operating free-air temperature (unless otherwise noted)†

Supply voltage range, V _{BAT}	27 V
Input voltage range, BUCK	-5 V to V _{BAT}
MODE	-0.3 V to 4.3 V
Mode maximum forced current	300 μ A
Operating virtual junction temperature range, T _J	-55°C to 150°C
Storage temperature range, T _{stg}	-65°C to 150°C
Lead temperature soldering 1,6 mm (1/16 inch) from case for 10 seconds	260°C

† Stresses beyond those listed under “absolute maximum ratings” may cause permanent damage to the device. These are stress ratings only, and functional operation of the device at these or any other conditions beyond those indicated under “recommended operating conditions” is not implied. Exposure to absolute-maximum-rated conditions for extended periods may affect device reliability.

‡ Unless otherwise specified, all voltages are with respect to GND.

AVAILABLE OPTIONS

T _J	PACKAGE
	PW§ (SSOP)
-40°C to 85°C	UCC2974PW
0°C to 70°C	UCC3974PW

§ This package is available taped and reeled. To order this packaging option, add an R suffix to the part number. (e.g. UCC2974PWR)

DISSIPATION RATING TABLE

PACKAGE	T _A ≤ 25°C	DERATING FACTOR	T _A = 70°C	T _A = 85°C
16-pin PW with solder	775 mW	6.2 mW/°C	495 mW	402 mW

recommended operating conditions

	MIN	NOM	MAX	UNIT
Supply voltage, V _{IN}	4.5		25	V
Mode voltage	0		4.3	V
DIM voltage	0		3.5	V
LFDSYNC amplitude	0		4.5	V

**UCC2974
PW PACKAGE
(TOP VIEW)**

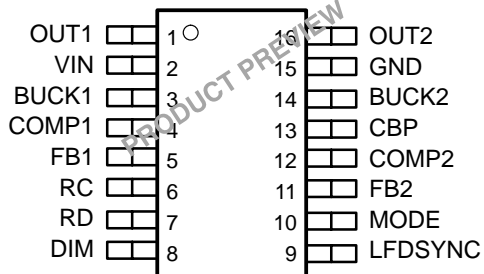

**UCC3974
PW PACKAGE
(TOP VIEW)**

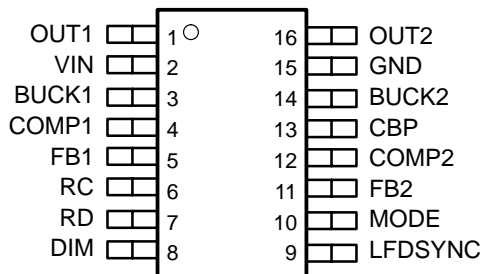

ACTUAL SIZE
(5,10mm x 6,60mm)

electrical characteristics over recommended operating virtual junction temperature range, $T_A = 0^\circ\text{C}$ to 70°C for the UCC3974, $T_A = -40^\circ\text{C}$ to 85°C , for the UCC2974, $T_A = T_J$.
 $V_{IN} = V_{BUCK} = 12\text{ V}$, $\text{MODE} = \text{OPEN}$ (unless otherwise noted)

supply current

PARAMETER		TEST CONDITIONS	MIN	TYP	MAX	UNIT
I_{IN}	V_{IN} supply current	$12\text{ V} \leq V_{IN} \leq 25\text{ V}$		1.7	3	mA
		$V_{IN} = 12\text{ V}$, MODE < 0.425 V		300	500	μA
	UVLO threshold voltage	LOW to HIGH	3.6	4	4.4	V
	UVLO hysteresis voltage		35	120	200	mV

output

PARAMETER		TEST CONDITIONS	MIN	TYP	MAX	UNIT
	High-level output voltage	$12\text{ V} \leq V_{IN} \leq 25\text{ V}$	8	10.5	13	V
	Low-level output voltage	MODE = 0.5 V, $I_{SINK} = 1\text{ mA}$		50	200	mV
	Rise time	$C_L = 1\text{ nF}$		170	350	ns
	Fall time	$C_L = 1\text{ nF}$		140	300	

oscillator

PARAMETER		TEST CONDITIONS	MIN	TYP	MAX	UNIT
	Free-running oscillator frequency	$12\text{ V} \leq V_{IN} \leq 25\text{ V}$, BUCK = V_{IN}	30	45	60	kHz
	Free-running synchronizable oscillator frequency	$12\text{ V} \leq V_{IN} \leq 25\text{ V}$, BUCK = $V_{IN}-3$			220	
	Maximum duty cycle	FB = 1 V	100%			
	Minimum duty cycle	FB = 2 V			0%	
	BUCK input bias current	BUCK = $V_{IN} = 12\text{ V}$		3	10	μA
		BUCK = $V_{IN} = 25\text{ V}$		3	10	
	Zero detect threshold voltage	Measured at BUCK with respect to V_{IN} , $12\text{ V} \leq V_{IN} \leq 25\text{ V}$	-2.4	-1.7	-1.1	V

error amplifier

PARAMETER		TEST CONDITIONS	MIN	TYP	MAX	UNIT
	Input voltage	COMP = FB, $0^\circ\text{C} \leq T_A \leq 70^\circ\text{C}$	1.465	1.5	1.535	V
		COMP = FB, $-40^\circ\text{C} \leq T_A \leq 85^\circ\text{C}$	1.455	1.5	1.545	
	Line regulation voltage	$12\text{ V} \leq V_{IN} \leq 25\text{ V}$		1	5	mV
	Input bias current			100	250	nA
	Open loop gain		60	80		dB
	High-level output voltage	FB = 1 V, $I_{SOURCE} = 50\text{ }\mu\text{A}$	3.5	3.7	4.2	V
	Low-level output voltage	FB = 2 V, $I_{SINK} = 50\text{ }\mu\text{A}$		0.15	0.35	
	Output source current	FB = 1 V, COMP = 2 V		-1.2	-0.3	mA
	Output sink current	FB = 2 V, COMP = 2 V	45	90		μA
	Unity gain bandwidth	$T_J = 25^\circ\text{C}$, See Note 1	2	5		MHz

NOTE 1: Ensured by design, not production tested.

UCC2974 UCC3974

SLUS485A – JULY 2001 – REVISED NOVEMBER 2001

electrical characteristics over recommended operating virtual junction temperature range, $T_A = 0^\circ\text{C}$ to 70°C for the UCC3974, $T_A = -40^\circ\text{C}$ to 85°C , for the UCC2974, $T_A = T_J$.
 $V_{IN} = V_{BUCK} = 12\text{ V}$, MODE = OPEN (unless otherwise noted)

mode select

PARAMETER	TEST CONDITIONS	MIN	TYP	MAX	UNIT
Enable threshold voltage		0.425	0.500	0.575	V
Output enable threshold voltage		0.85	1.00	1.15	
Open lamp detect enable voltage threshold		2.75	3	3.25	
Low-frequency dimming (LFD) voltage threshold		3.8	4.0	4.1	
MODE output current	MODE = 0.5 V	3.3	5.0	6.8	μA
MODE clamp voltage	MODE = OPEN	4.0	4.2	4.4	V

low-frequency dimming

PARAMETER	TEST CONDITIONS	MIN	TYP	MAX	UNIT
Duty cycle	$R_C = 400\text{ k}\Omega$, $C_{LFD} = 10\text{ nF}$, $R_D = 20\text{ k}\Omega$, DIM < 0.5 V	6%	10%	12%	
Maximum duty cycle	$R_C = 400\text{ k}\Omega$, $C_{LFD} = 10\text{ nF}$, $R_D = 20\text{ k}\Omega$, DIM > 3.1 V	100%			
Free-running oscillator frequency	$R_C = 400\text{ k}\Omega$, $C_{LFD} = 10\text{ nF}$, $R_D = 20\text{ k}\Omega$		200		Hz
Synchronized oscillator frequency	$R_C = 400\text{ k}\Omega$, $C_{LFD} = 10\text{ nF}$, FLFDSYNC = 400 Hz at $V_{LFDSYNC} = 2.25\text{ V}$		400		

open lamp

PARAMETER	TEST CONDITIONS	MIN	TYP	MAX	UNIT
Open lamp detect threshold voltage	$V_{IN} = 12\text{ V}$, Measured at VBUCK wrt V_{IN}	-8.5	-7.8	-7.0	V
	$V_{IN} = 25\text{ V}$, Measured at VBUCK wrt V_{IN}	-8.6	-7.8	-6.9	
Voltage clamp detect threshold voltage	Measured at VBUCK	-9.6	-8.75	-8.0	

NOTES: 1: Ensured by design, not production tested.

Terminal Functions

TERMINAL NAME NO.		I/O	DESCRIPTION
BUCK1	3	I	Voltage sense for the resonant tank.
BUCK2	14	I	
CBP	13	O	Internally generated low-voltage supply. Bypass to GND with 0.1- μ F bypass coordinator.
COMP1	4	O	Outputs of the error amplifiers for the two channels.
COMP2	12	O	
DIM	8	I	Reference signal applied to the LFD PWM that determines the LFD duty cycle.
FB1	5	I	Inverting inputs of the error amplifiers.
FB2	11	I	
GND	15	–	Power supply return.
LFDSYNC	9	I	2.5-V logic-compatible pin used to synchronize the LFD oscillator.
MODE	10	I	Start-up timing control.
OUT1	1	O	FET drive outputs for the two channels. The pin is driven between GND and internal voltage (typically 12 V).
OUT2	16	O	
RC	6	O	Connection for the low-frequency dimming (LFD) charge resistor. The other terminal of the resistor is connected to the LFD capacitor, C_{LFD} .
RD	7	O	Connection for low-frequency dimming (LFD) discharge resistor, R_D . The other terminal of the resistor is connected to the LFD capacitor, C_{LFD} . LFD frequency us user programmable by varying R_C , R_D and C_{FLD} .
VIN	2	I	Power supply input. 4.5 V to 25 V.

detailed pin descriptions

DIM – The range is approximately 0.5 V to 3 V for the programmed minimum 100% duty cycle. If the LFDSYNC pin is pulled above 2.25 V before MODE crosses the LFD enable threshold and is held high, the function of DIM changes from an analog voltage, which determines the LFD duty cycle, to a digital signal (2.5-V logic compatible) which turns the lamps on or off directly. This allows users to implement their own LFD solution and easily interface it to the UCC3974. Pulling this pin above 3.0 V (weak internal pull-up device is provided) causes the LFD section of the device to provide 100% LFD duty cycle.

LFDSYNC – This 2.5-V logic compatible pin is used to synchronize the LFD oscillator. A positive pulse restarts the LFD ramp. Weak internal pull-down device provided. This pin must be set high when digital LFD mode control is required.

MODE – This pin controls the start-up timing for the device. A capacitor is connected from this pin to ground and has a constant current forced into it. The pin voltage controls the state of the device. When the system has a power cycle, the pin is discharged to ground..

MODE PIN VOLTAGE	FUNCTION
$V_{MODE} < 0.5 \text{ V}$	All circuitry is disabled.
$V_{MODE} > 0.5 \text{ V}$	Internal circuitry is enabled.
$V_{MODE} > 1.0 \text{ V}$	Output driver is enabled.
$V_{MODE} > 3.0 \text{ V}$	Enable open lamp detection circuitry.
$V_{MODE} > 4.0 \text{ V}$	Enable low-frequency dimming (LFD).

BUCK1/BUCK2 – These pins are used to sense the voltage on the resonant tank. This voltage is used for synchronizing the internal high-frequency oscillators with the resonant tanks. This voltage is also used to detect an open lamp condition when MODE is above 3 V.

APPLICATION INFORMATION

functional block diagram

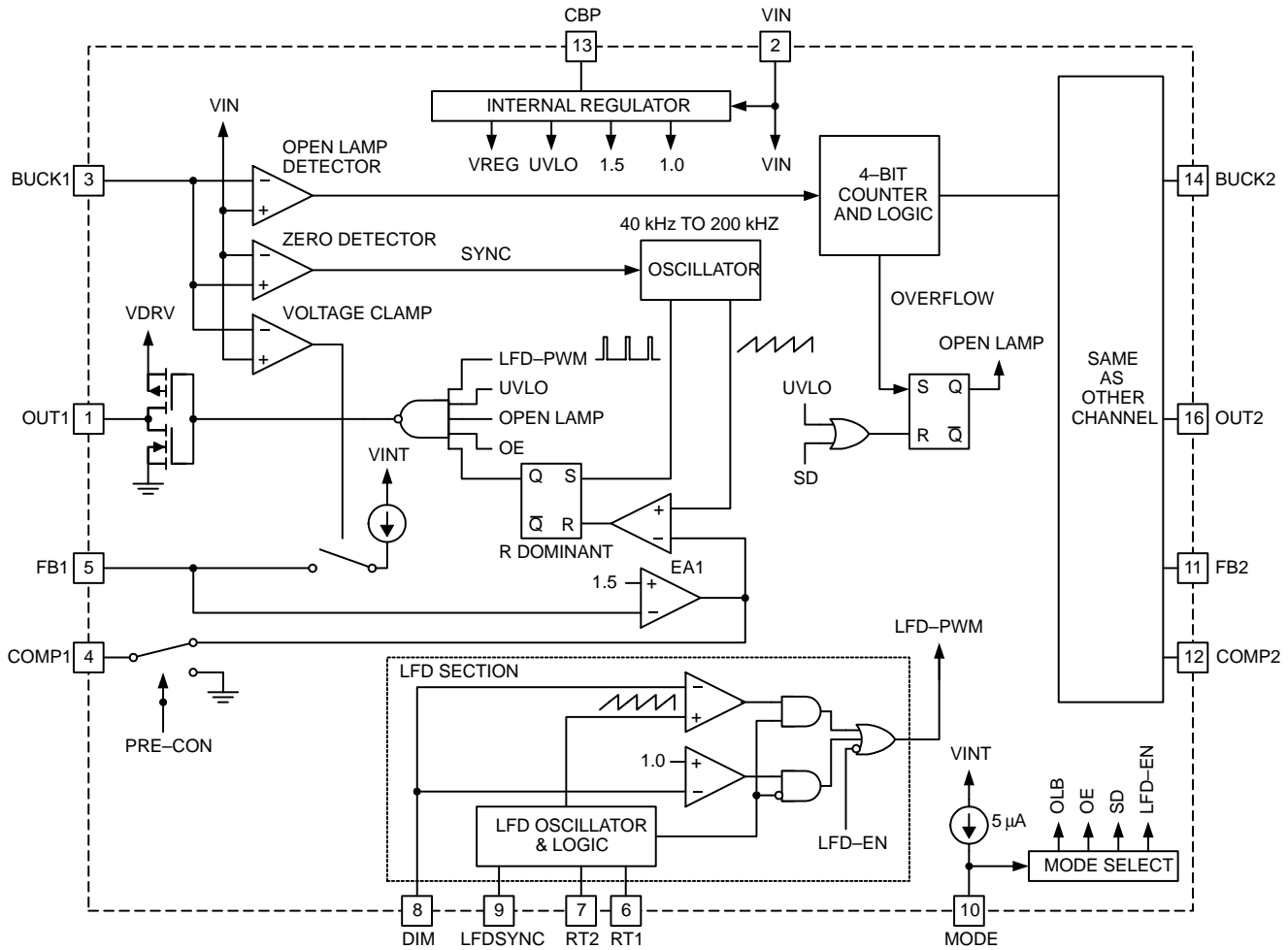

UDG-01021

general description

The UCC3974 extends the capabilities of the UCC3972 and UCC3973 backlight controllers. The basic functionality is the same as that for the UCC3972; a buck controlled current source feeding a royer oscillator CCFL circuit. As such the application information for the UCC3972 that pertains to the royer oscillator, buck controller and CCFL circuit in general apply to the UCC3974. Also, this device implements a voltage clamping scheme, similar to that of the UCC3973, using an internal current source to bias up the FB pin and thereby limiting the current available to the royer stage. This limits the voltage to which the secondary side of the transformer is exposed.

The extensions this device provides are two separately controlled channels to be used with two separate royer stages, and integrated low-frequency dimming (LFD) control .

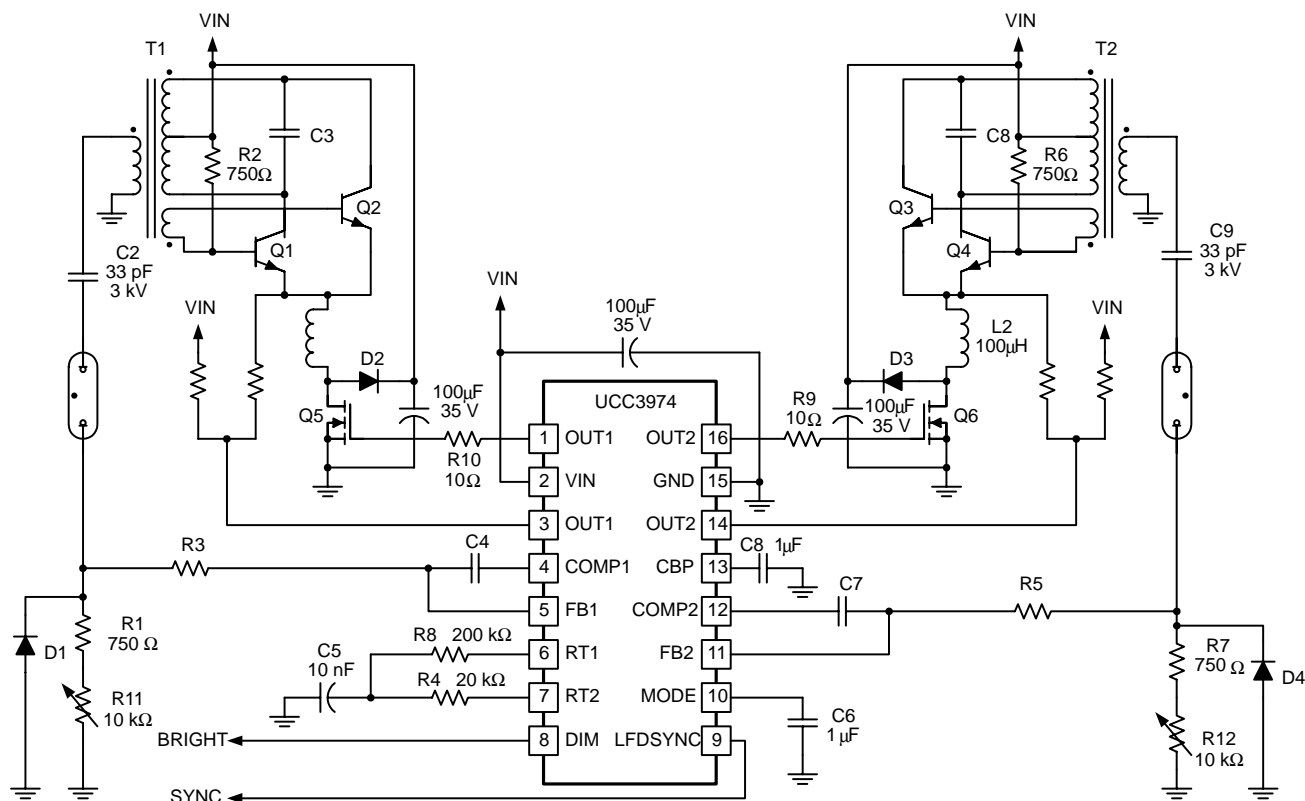

UDG-01020

Figure 1. Typical Dual-Channel Application

low-frequency dimming (LFD)

The low-frequency dimming section of the device is implemented as either a low frequency pulse width modulator (PWM) or as a direct digital input. In either case, the DIM pin is the controlling input. The type of DIM input is determined at startup. As the MODE pin transitions through the LFD_ENABLE threshold, the LFDSYNC pin is observed. When this pin is high, the DIM pin is a 2.5-V compatible logic input. When the DIM pin is high, the output is enabled. When it is low the output is disabled. The user is required to provide the correct frequency and duty ratio to the DIM pin in this mode. To change the mode of operation without power cycling the device, the MODE pin must be brought below the LFD_ENABLE threshold and then brought above it with the LFDSYNC pin held in the desired state.

To use DIM as an analog input, the LFDSYNC pin must be low when mode crosses the LFD_ENABLE threshold. In this mode, DIM becomes an analog input that varies the amount of time that the lamp is on during the period of the LFD oscillator. From 0.5 V to 3 V applied to the DIM pin varies the lamp on duty cycle from the programmed minimum to 100%.

NOTE: The analog dimming signal is sensitive to coupled noise from the lamps. Noise on this line will be seen as lamp flicker. It is highly recommended that precautions be taken to prevent noise coupling to this signal for optimum results.

Applying a pulse train to the LFDSYNC pin will synchronize the LFD oscillator to that pulse train. The frequency of the applied pulse train must be higher than the free running frequency of the oscillator.

APPLICATION INFORMATION

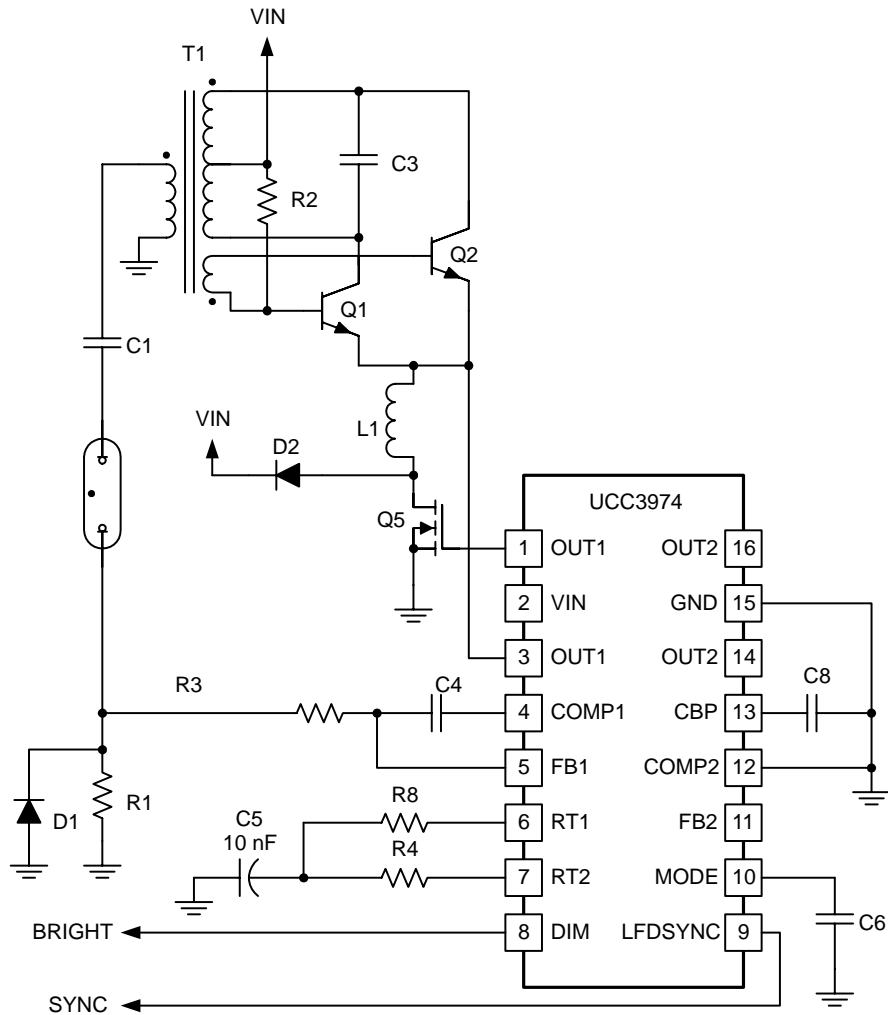

UDG-01022

Figure 2. Typical Single-Channel Application

APPLICATION INFORMATION

low-frequency dimming oscillator

The oscillator for the LFD section of the device is an R-C relaxation oscillator with programmable upslope and downslope on its timing ramp. Figure 3 shows a simplified LFD oscillator diagram that illustrates the principle. The charge time for the timing capacitor, C_T is the time it takes to charge that capacitor from 0.5 V to 3 V from a 4.2-V source through RC. This time is:

$$t_c = 1.126 \times R_C \times C_T \tag{1}$$

The discharge time is the time it takes to discharge the C_T capacitor from 3 V to 0.5 V through R_D connected to GND. This time is:

$$t_d = 1.792 \times R_D \times C_T \tag{2}$$

The period of the LFD oscillator is simply the sum of the charge and discharge times, or

$$T = C_T (1.126 \times R_C + 1.792 \times R_D) \tag{3}$$

The minimum duty cycle of the LFD PWM when operating in this mode is:

$$d_{\min} = \frac{t_d}{T} \tag{4}$$

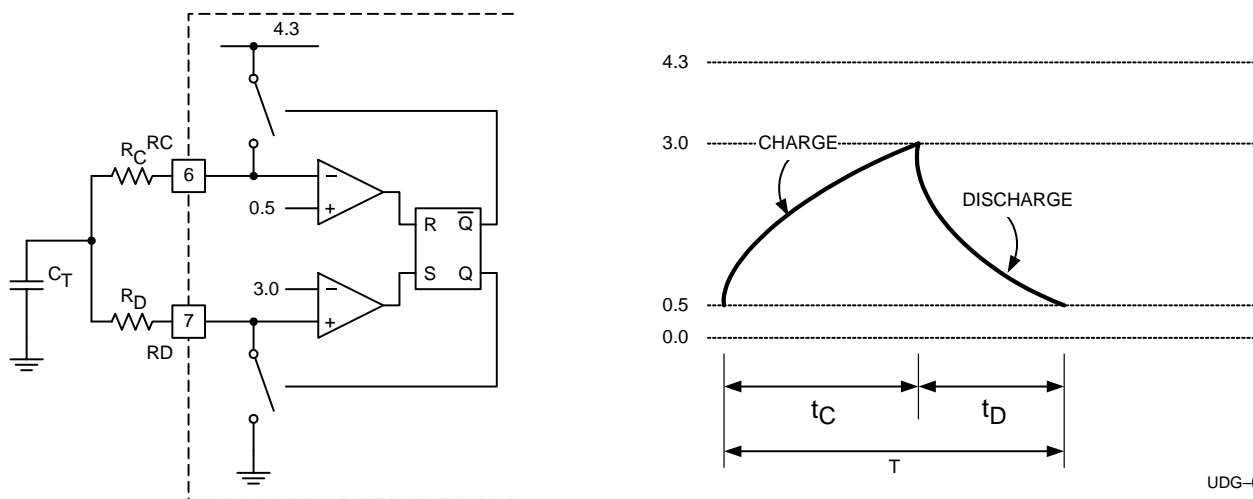

UDG-01025

Figure 3. LFD Oscillator

APPLICATION INFORMATION

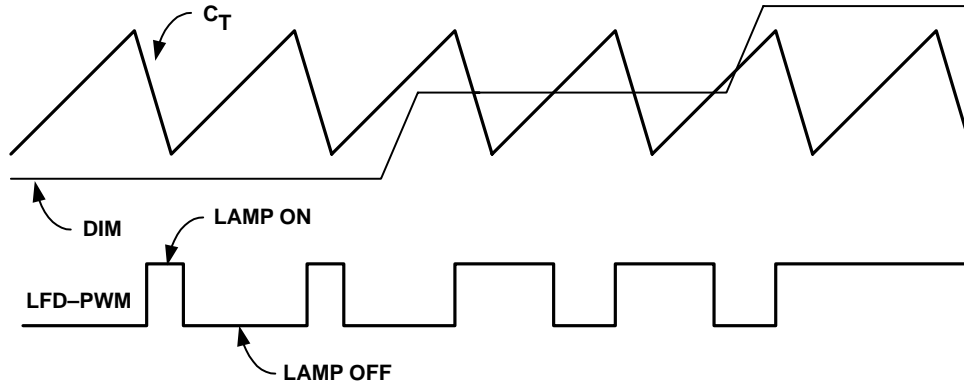

UDG-01024

Figure 4. LFD Waveforms

Note from the Figure 4 that the LFD-PWM output is turned on at the start of the discharge cycle and is turned off when C_T crosses the DIM signal or at the start of the charge cycle if DIM is less than the valley voltage of 0.5 V.

The LFD oscillator runs free at some frequency determined by the external timing components. The LFD oscillator can be synchronized to a system clock signal by applying this clock signal to the LFDSYNC pin. The signal must not be applied during power up since the MODE pin's crossing of the LFD_ENABLE threshold determines the function DIM takes on. If the synchronization signal is applied during power up, unpredictable results may occur. The synchronization frequency should be fairly close to (but higher than) the free run frequency of the oscillator. The operating range for the DIM signal is reduced when synchronizing the LFD oscillator just as with any other PWM. A synchronization pulse causes termination of the current charge cycle and starts a discharge. The ratio of free run to synchronization frequencies is the reduction factor for DIM's operating range.

For instance if the free-run frequency is 90% of the synchronization frequency, DIM is active over the 0.5-V to 2.75-V range instead of the 0.5-V to 3-V range. As a general recommendation, the free-run frequency should be kept within the 100-Hz to 1-kHz range, and synchronization should be limited to 120% of the free-run frequency to preserve control range on DIM.

output driver

The OUT1 and OUT2 pins are designed to directly drive small power MOSFETs. Output drive capability is limited by the 50-Ω maximum resistance of the driver. For large FETs where this drive level is insufficient, a separate driver is required. Note also that the output drive level is limited to approximately 12 V if the input voltage exceeds that level. For input voltages below 12 V, the driver drives to slightly below the input voltage.

startup sequence

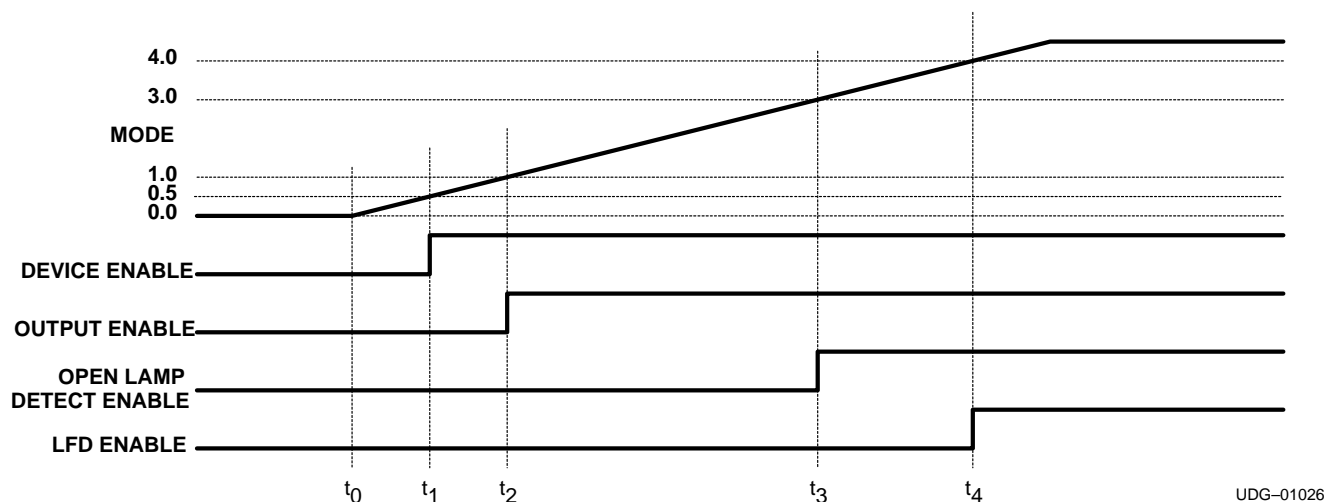

Figure 5. Start-Up Sequence

Figure 5 describes what happens during a typical startup sequence. At t_0 , power is applied to the system. A constant current source begins charging the external capacitor connected to the MODE pin. Until the voltage on the MODE pin reaches 0.5 V (t_1), the internal circuitry on the device is disabled and nothing happens at the outputs. As the voltage crosses 0.5 V, the internal circuitry is powered up. When the voltage crosses 1 V at t_2 , the outputs are enabled, allowing the buck stages to begin to charge up and to supply current to the royer stages.

During the period from t_2 to t_3 , the open lamp detection circuitry is disabled, preventing a false trip of the open lamp detector circuit when the lamp is trying to ignite for the first time. As a precaution against severe overvoltage on the high-voltage secondary of the transformer, a clamp circuit is included in the UCC3974. The function of the clamp circuit is to monitor the voltage on the BUCK pins and prevent that voltage to drop more than 8.7-V below the input rail. This is accomplished by sourcing a current from the FB pin when the BUCK voltage drops more than 8.7 V.

The magnitude of the current sourced from this pin is proportional to the excess drop of the BUCK voltage beyond 8.7 V. The maximum current sourced from this pin is approximately 200 μ A. Consequently, the impedance at the FB pin affects the speed at which this clamp becomes effective. A small capacitor and large resistors in the feedback network increases the effectiveness of this feature. From t_3 onward, the open lamp detector circuit is enabled. Each time the BUCK pin drops more than 7.8-V below V_{IN} , a 4-bit counter is clocked. If the counter reaches a count of 16 (4 bits) it declares an open lamp fault and shuts down the device. Resetting the device requires a power cycle. The counter in the open lamp detector is an up/down counter. If the BUCK pin only occasionally dips below the 7.8-V threshold, an open lamp condition is not declared since the counter is clocked down on each cycle in which BUCK does not cross the 7.8-V threshold. At time t_4 , LFD is enabled. Depending on the state of LFDSYNC when this threshold is crossed, DIM is either an analog input or a digital one.

PACKAGING INFORMATION

Orderable Device	Status (1)	Package Type	Package Drawing	Pins	Package Qty	Eco Plan (2)	Lead/Ball Finish (6)	MSL Peak Temp (3)	Op Temp (°C)	Device Marking (4/5)	Samples
UCC3974PW	ACTIVE	TSSOP	PW	16	90	Green (RoHS & no Sb/Br)	CU NIPDAU	Level-2-260C-1 YEAR	0 to 70	UCC3974	Samples

(1) The marketing status values are defined as follows:

ACTIVE: Product device recommended for new designs.

LIFEBUY: TI has announced that the device will be discontinued, and a lifetime-buy period is in effect.

NRND: Not recommended for new designs. Device is in production to support existing customers, but TI does not recommend using this part in a new design.

PREVIEW: Device has been announced but is not in production. Samples may or may not be available.

OBSELETE: TI has discontinued the production of the device.

(2) Eco Plan - The planned eco-friendly classification: Pb-Free (RoHS), Pb-Free (RoHS Exempt), or Green (RoHS & no Sb/Br) - please check <http://www.ti.com/productcontent> for the latest availability information and additional product content details.

TBD: The Pb-Free/Green conversion plan has not been defined.

Pb-Free (RoHS): TI's terms "Lead-Free" or "Pb-Free" mean semiconductor products that are compatible with the current RoHS requirements for all 6 substances, including the requirement that lead not exceed 0.1% by weight in homogeneous materials. Where designed to be soldered at high temperatures, TI Pb-Free products are suitable for use in specified lead-free processes.

Pb-Free (RoHS Exempt): This component has a RoHS exemption for either 1) lead-based flip-chip solder bumps used between the die and package, or 2) lead-based die adhesive used between the die and leadframe. The component is otherwise considered Pb-Free (RoHS compatible) as defined above.

Green (RoHS & no Sb/Br): TI defines "Green" to mean Pb-Free (RoHS compatible), and free of Bromine (Br) and Antimony (Sb) based flame retardants (Br or Sb do not exceed 0.1% by weight in homogeneous material)

(3) MSL, Peak Temp. - The Moisture Sensitivity Level rating according to the JEDEC industry standard classifications, and peak solder temperature.

(4) There may be additional marking, which relates to the logo, the lot trace code information, or the environmental category on the device.

(5) Multiple Device Markings will be inside parentheses. Only one Device Marking contained in parentheses and separated by a "~" will appear on a device. If a line is indented then it is a continuation of the previous line and the two combined represent the entire Device Marking for that device.

(6) Lead/Ball Finish - Orderable Devices may have multiple material finish options. Finish options are separated by a vertical ruled line. Lead/Ball Finish values may wrap to two lines if the finish value exceeds the maximum column width.

Important Information and Disclaimer:The information provided on this page represents TI's knowledge and belief as of the date that it is provided. TI bases its knowledge and belief on information provided by third parties, and makes no representation or warranty as to the accuracy of such information. Efforts are underway to better integrate information from third parties. TI has taken and continues to take reasonable steps to provide representative and accurate information but may not have conducted destructive testing or chemical analysis on incoming materials and chemicals. TI and TI suppliers consider certain information to be proprietary, and thus CAS numbers and other limited information may not be available for release.

In no event shall TI's liability arising out of such information exceed the total purchase price of the TI part(s) at issue in this document sold by TI to Customer on an annual basis.

IMPORTANT NOTICE

Texas Instruments Incorporated and its subsidiaries (TI) reserve the right to make corrections, enhancements, improvements and other changes to its semiconductor products and services per JESD46, latest issue, and to discontinue any product or service per JESD48, latest issue. Buyers should obtain the latest relevant information before placing orders and should verify that such information is current and complete. All semiconductor products (also referred to herein as "components") are sold subject to TI's terms and conditions of sale supplied at the time of order acknowledgment.

TI warrants performance of its components to the specifications applicable at the time of sale, in accordance with the warranty in TI's terms and conditions of sale of semiconductor products. Testing and other quality control techniques are used to the extent TI deems necessary to support this warranty. Except where mandated by applicable law, testing of all parameters of each component is not necessarily performed.

TI assumes no liability for applications assistance or the design of Buyers' products. Buyers are responsible for their products and applications using TI components. To minimize the risks associated with Buyers' products and applications, Buyers should provide adequate design and operating safeguards.

TI does not warrant or represent that any license, either express or implied, is granted under any patent right, copyright, mask work right, or other intellectual property right relating to any combination, machine, or process in which TI components or services are used. Information published by TI regarding third-party products or services does not constitute a license to use such products or services or a warranty or endorsement thereof. Use of such information may require a license from a third party under the patents or other intellectual property of the third party, or a license from TI under the patents or other intellectual property of TI.

Reproduction of significant portions of TI information in TI data books or data sheets is permissible only if reproduction is without alteration and is accompanied by all associated warranties, conditions, limitations, and notices. TI is not responsible or liable for such altered documentation. Information of third parties may be subject to additional restrictions.

Resale of TI components or services with statements different from or beyond the parameters stated by TI for that component or service voids all express and any implied warranties for the associated TI component or service and is an unfair and deceptive business practice. TI is not responsible or liable for any such statements.

Buyer acknowledges and agrees that it is solely responsible for compliance with all legal, regulatory and safety-related requirements concerning its products, and any use of TI components in its applications, notwithstanding any applications-related information or support that may be provided by TI. Buyer represents and agrees that it has all the necessary expertise to create and implement safeguards which anticipate dangerous consequences of failures, monitor failures and their consequences, lessen the likelihood of failures that might cause harm and take appropriate remedial actions. Buyer will fully indemnify TI and its representatives against any damages arising out of the use of any TI components in safety-critical applications.

In some cases, TI components may be promoted specifically to facilitate safety-related applications. With such components, TI's goal is to help enable customers to design and create their own end-product solutions that meet applicable functional safety standards and requirements. Nonetheless, such components are subject to these terms.

No TI components are authorized for use in FDA Class III (or similar life-critical medical equipment) unless authorized officers of the parties have executed a special agreement specifically governing such use.

Only those TI components which TI has specifically designated as military grade or "enhanced plastic" are designed and intended for use in military/aerospace applications or environments. Buyer acknowledges and agrees that any military or aerospace use of TI components which have **not** been so designated is solely at the Buyer's risk, and that Buyer is solely responsible for compliance with all legal and regulatory requirements in connection with such use.

TI has specifically designated certain components as meeting ISO/TS16949 requirements, mainly for automotive use. In any case of use of non-designated products, TI will not be responsible for any failure to meet ISO/TS16949.

Products

Audio	www.ti.com/audio
Amplifiers	amplifier.ti.com
Data Converters	dataconverter.ti.com
DLP® Products	www.dlp.com
DSP	dsp.ti.com
Clocks and Timers	www.ti.com/clocks
Interface	interface.ti.com
Logic	logic.ti.com
Power Mgmt	power.ti.com
Microcontrollers	microcontroller.ti.com
RFID	www.ti-rfid.com
OMAP Applications Processors	www.ti.com/omap
Wireless Connectivity	www.ti.com/wirelessconnectivity

Applications

Automotive and Transportation	www.ti.com/automotive
Communications and Telecom	www.ti.com/communications
Computers and Peripherals	www.ti.com/computers
Consumer Electronics	www.ti.com/consumer-apps
Energy and Lighting	www.ti.com/energy
Industrial	www.ti.com/industrial
Medical	www.ti.com/medical
Security	www.ti.com/security
Space, Avionics and Defense	www.ti.com/space-avionics-defense
Video and Imaging	www.ti.com/video

TI E2E Community

e2e.ti.com

Looking for pricing, stock, or lifecycle information?

Click below to explore more details on WIN SOURCE:

 [View UCC3974PWR](#) on WIN SOURCE

 [Texas Instruments](#) Information

Optimize Your Supply Chain with WIN SOURCE Solutions

-  Global Sourcing Solution
-  Obsolete Management
-  Cost Control Management
-  Shortage Management
-  Alternative Solution
-  Excess Inventory Management