



**THE DATASHEET OF  
MASW-010351-TR3000**



## SP5T High Isolation Terminated Switch 0.01 - 4.0 GHz

Rev. V1

### Features

- Isolation: 51 dB @ 2.1 GHz
- Insertion Loss: 1.0 dB @ 2.1 GHz
- Input IP3: 50 dBm Typical @ 2.1 GHz
- Integral CMOS 3:5 Decoder, Only 3 Control Pins
- Low Gate Lag for timing sensitive applications
- 6 States: 5 ON paths and All-Off State
- 50  $\Omega$  Terminated Outputs (Off-State)
- Lead-Free 4 mm 24-Lead PQFN package
- RoHS\* Compliant and 260°C Reflow Compatible

### Description

The MASW-010351 is an industry leading high isolation single pole five throw (SP5T) switch. This device design is optimized to take advantage of separate GaAs pHEMT switch die and CMOS driver die. The switch circuit design is symmetric and combined with the separate CMOS decoder allows it to maintain an excellent combination of insertion loss and isolation for all states. This makes the device ideal for band switching in multi-channel and multi-mode base-station applications as well as other applications where a compact, high isolation, SP4T switch is required.

The MASW-010351 switch die is fabricated using a mature 0.5 micron gate length GaAs pHEMT process and features full passivation for enhanced performance and reliability.

The MASW-010351 is offered in an industry standard lead-free 4mm 24-Lead PQFN RoHS compliant plastic package, which is ideal for high volume surface mount reflow assembly.

### Ordering Information <sup>1,2</sup>

Part Number	Package
MASW-010351-TR3000	3000 piece reel
MASW-010351-001SMB	Sample Test Board

1. Reference Application Note M513 for reel size information.
2. All sample boards include 5 loose parts.

### Functional Schematic

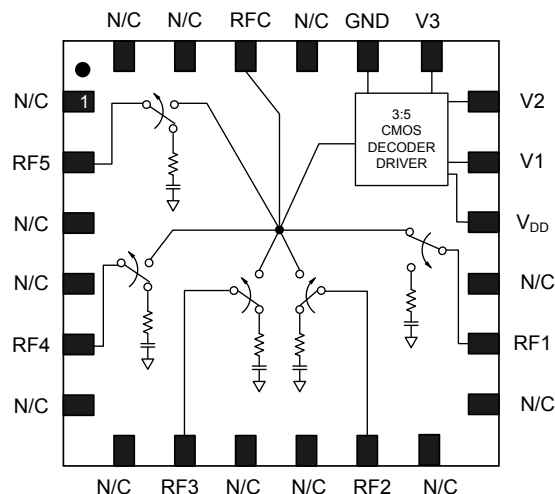

### Pin Configuration <sup>3,4</sup>

Pin No.	Description	Pin No.	Description
1	No Connection	13	No Connection
2	RF5	14	RF1
3	No Connection	15	No Connection
4	No Connection	16	V <sub>DD</sub>
5	RF4	17	V1 Control
6	No Connection	18	V2 Control
7	No Connection	19	V3 Control
8	RF3	20	Ground
9	No Connection	21	No Connection
10	No Connection	22	RFC
11	RF2	23	No Connection
12	No Connection	24	No Connection
		25	Ground (paddle)

3. M/A-COM Technology Solutions recommends connecting all N/C pins to RF and DC ground in the PCB layout.
4. The exposed pad centered on the package bottom (P25) MUST be connected to RF and DC ground in the PCB layout.

\*Restrictions on Hazardous Substances, European Union Directive 2002/95/EC.

## SP5T High Isolation Terminated Switch 0.01 - 4.0 GHz

Rev. V1

Electrical Specifications <sup>5</sup>:  $T_A = +25^\circ\text{C}$ ,  $Z_0 = 50 \Omega$ ,  $V_{DD} = +3.0\text{V}$ ,  $V_C = 0\text{V} / +3.0\text{V}$

Parameter	Test Conditions	Units	Min.	Typ.	Max.
Insertion Loss (All Paths)	0.9 GHz	dB	—	0.8	—
	2.1 GHz			1.0	1.2
	2.6 GHz			1.6	—
	4.0 GHz			1.9	—
Isolation	RFC-RF1, 2.1 GHz	dB	55	60	—
	RFC-RF2, 2.1 GHz		52	55	
	RFC-RF3, 2.1 GHz		51	54	
	RFC-RF4, 2.1 GHz		48	51	
	RFC-RF5, 2.1 GHz		48	51	
Return Loss (All RF ports)	2.1 GHz	dB	—	14	—
Input IP3	Two Tone, +10 dBm/tone, 5 MHz Spacing, 2.1 GHz	dBm	—	50	—
Input P1dB	2.1 GHz	dBm	—	27	—
Trise, Tfall	10% to 90% RF, 90% to 10% RF, RF=2.1GHz	ns	—	20	—
Ton, Toff	50% control to 90% RF, and 50% control to 10% RF, RF=2.1GHz	ns	—	40	—
$I_{DD}$	$V_{DD} = +3.0\text{V}$	$\mu\text{A}$	—	1.0	—
Control Current	$V_C = 0\text{V} / +3.0\text{V}$	$\mu\text{A}$	—	1.0	5.0

5. External DC blocking capacitors are required on all RF ports. Typical performance specifications are with 1000 pF blocking and decoupling capacitors, as shown on the application schematic.

### Absolute Maximum Ratings <sup>6,7</sup>

Parameter	Absolute Maximum
Input Power (RFC Port, ON state)	+20 dBm (0.05 - 0.5 GHz) +30 dBm (0.5 - 4.0 GHz)
$V_{DD}$ Supply	-0.5 V to +7.0 V
Control Voltage	-0.5 V < $V_C$ < $V_{DD} + 0.5$ V ( $V_C$ not to exceed 7.0 V)
Operating Temperature	-40°C to +85°C
Storage Temperature	-65°C to +150°C

6. Exceeding any one or combination of these limits may cause permanent damage to this device.  
7. M/A-COM Technology Solutions does not recommend sustained operation near these survivability limits.

### Truth Table <sup>8</sup>

V1	V2	V3	RFC-RF1	RFC-RF2	RFC-RF3	RFC-RF4	RFC-RF5
0	0	0	Unsupported				
1	0	0	On	Off	Off	Off	Off
0	1	0	Off	On	Off	Off	Off
1	1	0	Off	Off	On	Off	Off
0	0	1	Off	Off	Off	On	Off
1	0	1	Off	Off	Off	Off	On
0	1	1	Off	Off	Off	Off	Off
1	1	1	Off	Off	Off	Off	Off

8. Positive Control: 1 =  $0.7 \cdot V_{DD}$  to  $V_{DD}$   
0 = 0 V to  $0.3 \cdot V_{DD}$

## SP5T High Isolation Terminated Switch 0.01 - 4.0 GHz

Rev. V1

### Application Schematic<sup>9,10,11</sup>

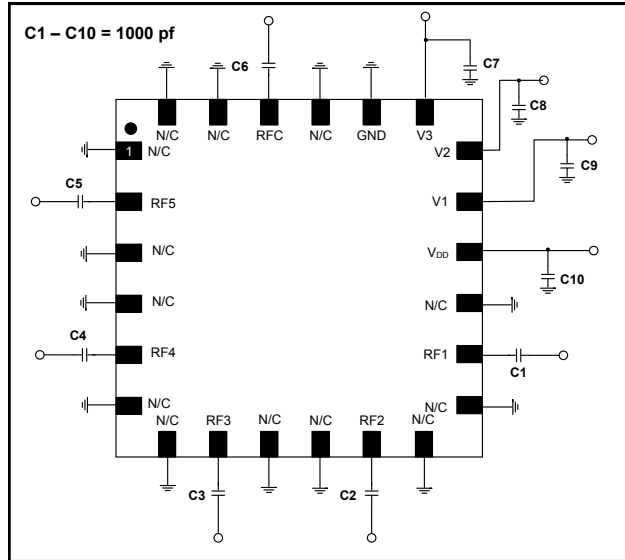

9. The exposed pad centered on the package bottom must be connected to ground for RF, DC and thermal considerations.
10. All blocking capacitors and decoupling capacitors = 1000 pF
11. M/A-COM Technology Solutions recommends connecting all N/C pins to RF and DC ground in the PCB layout as shown.

### Handling Procedures

Please observe the following precautions to avoid damage:

### Static Sensitivity

Gallium Arsenide Integrated Circuits are sensitive to electrostatic discharge (ESD) and can be damaged by static electricity. Proper ESD control techniques should be used when handling these devices. An external protection circuit using ESD/Transient protection devices on the RF ports can be used to protect the IC if required in application.

Please reference application note AN3007 on <http://www.macomtech.com> for further detail.

### Lead-Free 4 mm 24-Lead PQFN<sup>†</sup>

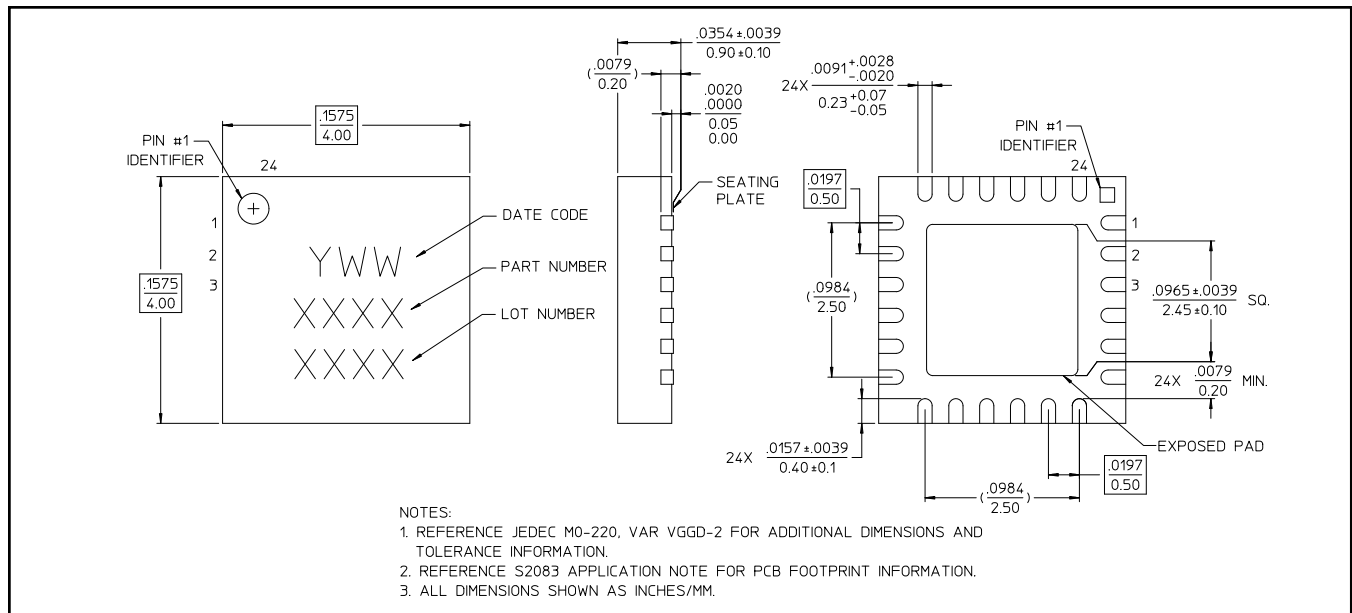

<sup>†</sup> Reference Application Note S2083 for lead-free solder reflow recommendations.  
Meets JEDEC moisture sensitivity level 1 requirements.  
Plating is 100% matte tin over copper.

## Typical Performance Curves:

**Insertion Loss**

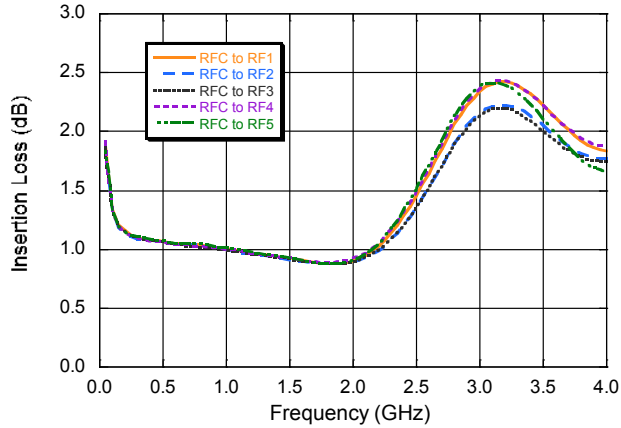

**Insertion Loss**

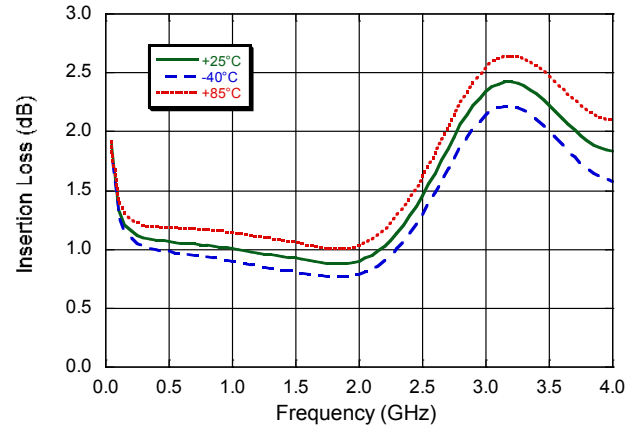

**Isolation**

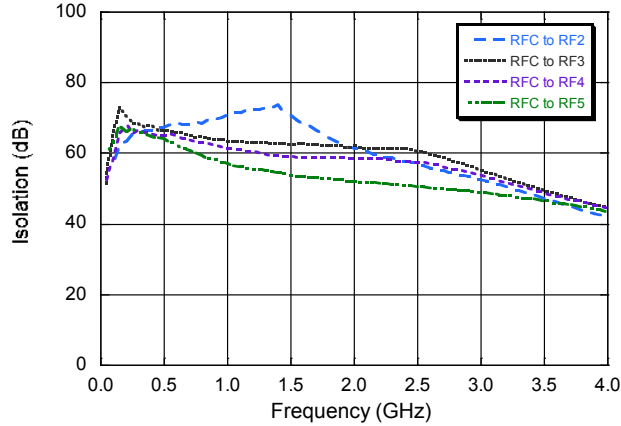

**Isolation\_RFC - RF1**

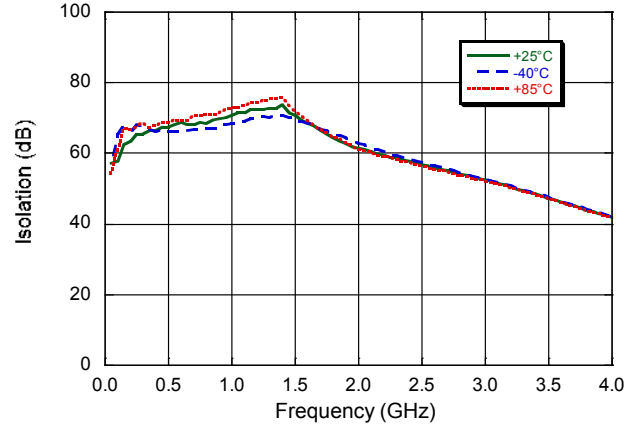

M/A-COM Technology Solutions Inc. All rights reserved.

Information in this document is provided in connection with M/A-COM Technology Solutions Inc ("MACOM") products. These materials are provided by MACOM as a service to its customers and may be used for informational purposes only. Except as provided in MACOM's Terms and Conditions of Sale for such products or in any separate agreement related to this document, MACOM assumes no liability whatsoever. MACOM assumes no responsibility for errors or omissions in these materials. MACOM may make changes to specifications and product descriptions at any time, without notice. MACOM makes no commitment to update the information and shall have no responsibility whatsoever for conflicts or incompatibilities arising from future changes to its specifications and product descriptions. No license, express or implied, by estoppel or otherwise, to any intellectual property rights is granted by this document.

THESE MATERIALS ARE PROVIDED "AS IS" WITHOUT WARRANTY OF ANY KIND, EITHER EXPRESS OR IMPLIED, RELATING TO SALE AND/OR USE OF MACOM PRODUCTS INCLUDING LIABILITY OR WARRANTIES RELATING TO FITNESS FOR A PARTICULAR PURPOSE, CONSEQUENTIAL OR INCIDENTAL DAMAGES, MERCHANTABILITY, OR INFRINGEMENT OF ANY PATENT, COPYRIGHT OR OTHER INTELLECTUAL PROPERTY RIGHT. MACOM FURTHER DOES NOT WARRANT THE ACCURACY OR COMPLETENESS OF THE INFORMATION, TEXT, GRAPHICS OR OTHER ITEMS CONTAINED WITHIN THESE MATERIALS. MACOM SHALL NOT BE LIABLE FOR ANY SPECIAL, INDIRECT, INCIDENTAL, OR CONSEQUENTIAL DAMAGES, INCLUDING WITHOUT LIMITATION, LOST REVENUES OR LOST PROFITS, WHICH MAY RESULT FROM THE USE OF THESE MATERIALS.

MACOM products are not intended for use in medical, lifesaving or life sustaining applications. MACOM customers using or selling MACOM products for use in such applications do so at their own risk and agree to fully indemnify MACOM for any damages resulting from such improper use or sale.

5

---

M/A-COM Technology Solutions Inc. (MACOM) and its affiliates reserve the right to make changes to the product(s) or information contained herein without notice.  
Visit [www.macom.com](http://www.macom.com) for additional data sheets and product information.

## Looking for pricing, stock, or lifecycle information?

Click below to explore more details on WIN SOURCE:

- ⊖ [View MASW-010351-TR3000 on WIN SOURCE](#)
- ⊖ [M/A-Com Technology Solutions Information](#)

## Optimize Your Supply Chain with WIN SOURCE Solutions

- ✓ Global Sourcing Solution
- ✓ Obsolete Management
- ✓ Cost Control Management
- ✓ Shortage Management
- ✓ Alternative Solution
- ✓ Excess Inventory Management