



**THE DATASHEET OF
ZXFV202E5TA**



ZXFV201, ZXFV202, ZXFV203, ZXFV204

Quad, single, triple and dual video amplifiers

Device description

The ZXFV201, ZXFV202, ZXFV203 and ZXFV204 are quad, single, triple and dual, respectively, high speed amplifiers designed for video and other high speed applications.

Their low differential gain and phase performance make them ideal for video amplifier buffer applications.

The quad allows one IC to drive RGBS format component video signals, while the triple provides RGB component video buffer/driver. The dual amplifier is a mainstay of the video market providing two channels in the space of 1 single in SO8. The small size of the ZXFV202 in SOT23 allows it to be placed where needed for position/size critical applications.

Together with high output drive and slew rate capability, they bring high performance to video applications.

Ordering information

Part number	Description	Status	Reel size (inches)	Qty.	Part mark
ZXFV202E5TA	Single	Active	7	3,000	V202
ZXFV202E5TD	Single	Obsolete	7	500	V202
ZXFV202N8TA	Single	Obsolete	7	500	ZXFV202
ZXFV204N8TA	Dual	Obsolete	7	500	ZXFV204
ZXFV204N8TC	Dual	Active	13	2,500	ZXFV204
ZXFV203N14TA	Triple	Active	7	500	ZXFV203
ZXFV203N14TC	Triple	Obsolete	13	2,500	ZXFV203
ZXFV201N14TA	Quad	LTB	7	500	ZXFV201
ZXFV201N14TC	Quad	Obsolete	13	2,500	ZXFV201

Features

- High speed
- Gain of 1 - 3dB bandwidth 210MHz
- Slew rate 380V/ μ s
- Good video
- 25 MHz 0.1dB bandwidth
- Differential gain 0.04%
- Differential phase 0.04°
- 40mA output current @ 3V Output
- Characterized up to 300pF load
- \pm 5 Volt supply operation
- Supply current 7.5mA per amplifier

Applications

- Industry standard pinouts
- Video gain stages
- CCTV buffer
- Video distribution
- RGB buffering
- Home theater
- High speed ADC signal input drive
- Cable driving

Application diagram

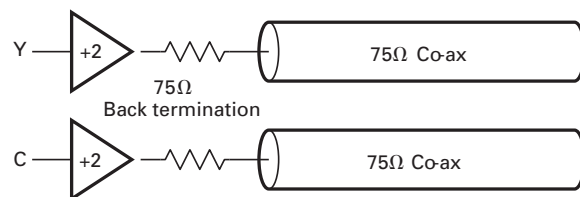

Dual amplifier S - video driver

ZXFV201, ZXFV202, ZXFV203, ZXFV204

Absolute maximum ratings over operating free-air temperature (unless otherwise stated ^(a))

Supply voltage (V_{S+} to V_{S-})	-0.5V to +11V
Input voltage (V_{IN-} , V_{IN+}) ^(b)	$V_{S-} - 0.5V$ to $V_{S+} + 0.5V$
Differential input voltage (V_{ID})	$\pm 3V$
Inverting input current (I_{IN-}) ^(c)	$\pm 5mA$
Output current (continuous, $T_J < 110^\circ C$)	$\pm 60mA$
Internal power dissipation	See power dissipation derating table
Storage temperature range	$-65^\circ C$ to $+150^\circ C$
Operating ambient junction temperature (T_{JMAX})	$150^\circ C$

NOTES:

- (a) Stresses above those listed under Absolute maximum ratings may cause permanent damage to the device. This is a stress rating only; functional operation of the device at these or any other conditions above those indicated in the operational section of this specification is not implied. Exposure to absolute maximum rating conditions for extended periods may affect device reliability.
- (b) During power-up and power-down, these voltage ratings require that signals be applied only when the power supply is connected.
- (c) At high closed loop gains and low gain setting resistors care must be taken if large input signals are applied to the device which cause the output stage to saturate for extended periods of time.

Power derating table

Package	Theta-ja	Power rating at 25°C
SOT23-5	195°C/W	0.64W
SO8	168°C/W	0.74W
SO14	120°C/W	1.04W

Recommended operating conditions

Parameter		Min.	Max.	Unit
$V_{S\pm}$	Dual supply voltage range	± 4.75	± 5.25	V
V_{CMR}	Common mode input voltage range	-3	+3	V
T_A	Ambient temperature range	-40	85	°C

Recommended resistor values

$V_{S\pm} = 5V$, $C_L = 10pF$

G_{CL}	R_F	R_G	Peaking
1	680	n/c	2 dB
	820		0
	1000		-2dB
2	430	430	2dB
	470	470	1.5dB
	560	560	0

ZXFV201, ZXFV202, ZXFV203, ZXFV204

DC electrical characteristics ($\pm 5V$ power supplies, $T_{amb} = 25^{\circ}C$ unless otherwise stated. $R_f = 1k\Omega$, $R_L = 150\Omega$, $C_L \leq 10pF$)

Parameter	Conditions	Test	Min.	Typ.	Max.	Unit
Supply voltage V+ operating range			4.75	5	5.25	V
Supply voltage V- operating range			-5.25	-5	-4.75	V
Supply current/per channel		P	5.0	7.5	10	mA
Input common mode voltage range		P		± 3		V
Input offset voltage		P		1	10	mV
Output offset voltage		P		2	20	mV
Input bias current, non-inverting input		P		5	10	μA
Input resistance		P	1.5	2	6.5	$M\Omega$
Output voltage swing	$I_{OUT} = 40mA$	P		± 3		V
Output drive current	$V_{IN} = 3V$	P	40			mA
Positive PSRR	$\Delta V_+ = \pm 0.25$	P	49	57		dB
Negative PSRR	$\Delta V_- = \pm 0.25$	P	49	57		dB

Test - P = production tested. C = characterized

AC electrical characteristics ($\pm 5V$, $R_f = 470\Omega$, $G = 2$, $C_L = 10pF$, $T_A = 25^{\circ}C$, unless otherwise stated)

Parameter	Conditions	Min	Typ	Max	Unit
BW ₋₃ Bandwidth, -3dB	$V_{OUT} = 0.2V_{PP}$ $G = +2$, $R_F = 470\Omega$		210		MHz
	$V_{OUT} = 0.2V_{PP}$ $G = +1$, $R_F = 820\Omega$		210		
BW _{0.1} Bandwidth, $\pm 0.1dB$	$V_{OUT} = 0.2V_{PP}$		30		MHz
SR Slew Rate	$V_{OUT} = 2V_{PP}$ $G = +2$, $R_F = 470\Omega$		600		V/ μs
	$V_{OUT} = 2V_{PP}$ $G = +1$, $R_F = 820\Omega$		380		
t _r Rise time	$V_{OUT} = \pm 1V$, 10% - 90%		5.8		ns
t _f Fall time			4.6		
t _p Propagation delay			2.6		
dG Differential phase, NTSC	NTSC/PAL, 280mV _{PP}		0.04		%
dP Differential phase, NTSC	DC = -1.428V to +1.428 V		0.04°		

ZXFV201, ZXFV202, ZXFV203, ZXFV204

Applications information

A typical circuit application is shown in Figure 1. This is suitable for 75Ω transmission line connections at both the input and the output and is useful for distribution of wide-band signals such as video via cables. The 75Ω reverse terminating resistor R4 gives the correct matching condition to a terminated video cable. The amplifier load is then 150Ω in parallel with the local feedback network.

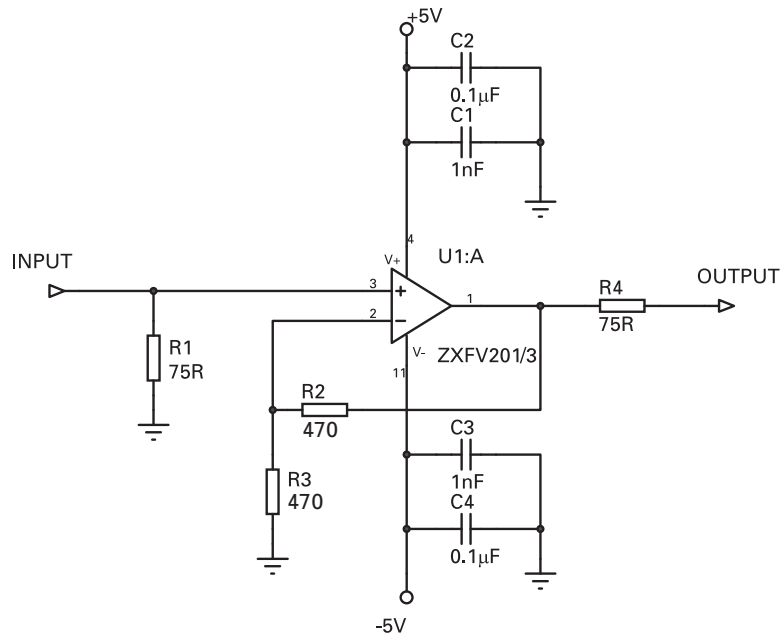

Figure 1 Typical video signal application circuit, gain = 2 (overall gain = 1 for 75Ω load)

The wide bandwidth of this device necessitates some care in the layout of the printed circuit. A continuous ground plane is required under the device and its signal connection paths, to provide the shortest possible ground return paths for signals and power supply filtering. A double-sided or multi-layer PCB construction is required, with plated-through via holes providing closely spaced low-inductance connections from some components to the continuous ground plane.

For the power supply filtering, low inductance surface mount capacitors are normally required. It has been found that very good RF decoupling is provided on each supply using a 1000pF NPO size 0805 or smaller ceramic surface mount capacitor, closest to the device pin, with an adjacent 0.1μF X7R capacitor. Other configurations are possible and it may be found that a single 0.01μF X7R capacitor on each supply gives good results. However this should be supported by larger decoupling capacitors elsewhere on the printed circuit board. Values of 1 to 10μF are recommended, particularly where the voltage regulators are located more than a few inches from the device. These larger capacitors are recommended to be solid tantalum electrolytic or ceramic types.

Note particularly that the inverting input of this current feedback type of amplifier is sensitive to small amounts of capacitance to ground which occur as part of the practical circuit board layout. This capacitance affects bandwidth, frequency response peaking and pulse overshoot. Therefore to minimize this capacitance, the feedback components R2 and R3 of Figure 1 should be positioned as close as possible to the inverting input connection.

ZXFV201, ZXFV202, ZXFV203, ZXFV204

The frequency response and pulse response will vary according to particular values of resistors and layout capacitance. The response can be tailored for the application to some extent by choice of the value of feedback resistor. Figures 2 and 3 show the small signal unity gain and gain of 2 frequency responses.

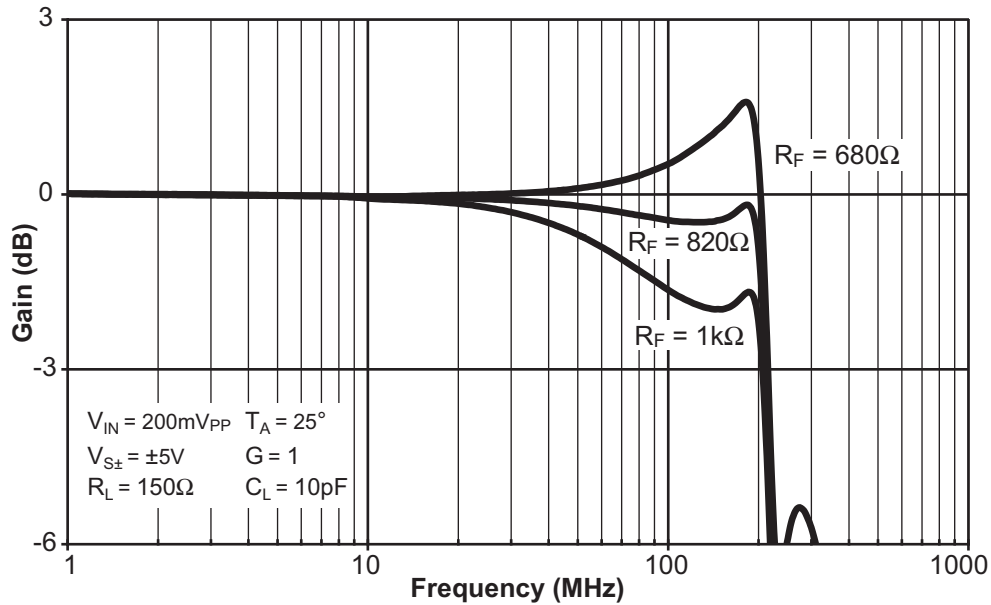

Figure 2 Unity gain small signal bandwidth

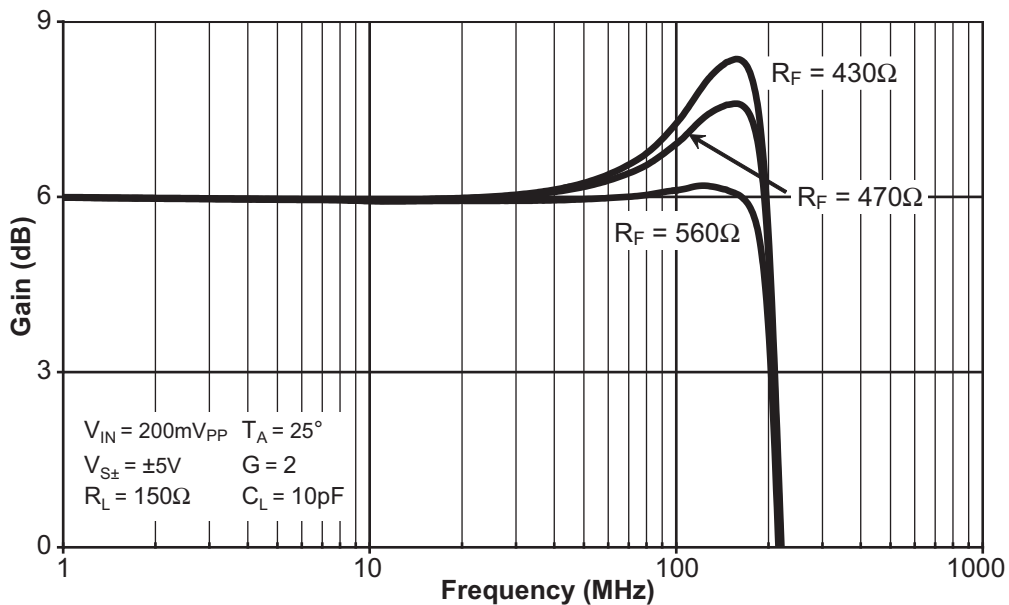
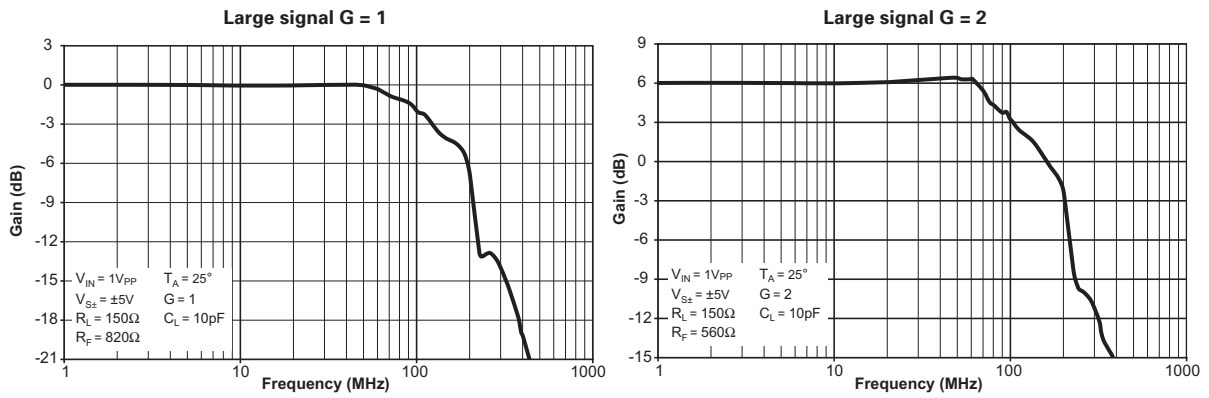

Figure 3 Gain of 2 small signal bandwidth

ZXFV201, ZXFV202, ZXFV203, ZXFV204

Figures 4 and 5 show the large signal unity gain of 2 frequency responses.



Figures 4 and 5 Large signal unity gain of 2 frequency response

The ZXFV20x family are primarily video amplifiers; Figures 6 and 7 show the NTSC/PAL differential gain and phase errors at a gain of 2.

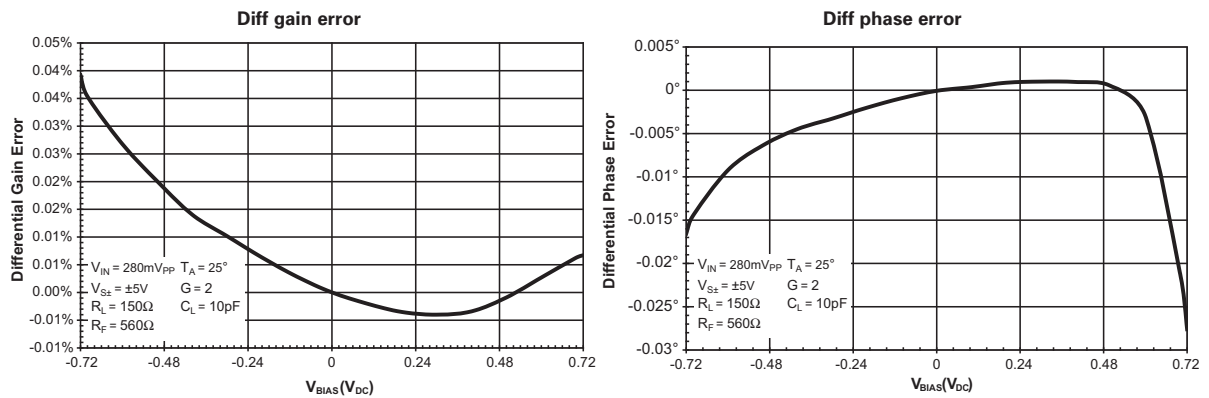

Figures 6 and 7 NTSC/PAL differential gain and phase errors at a gain of 2

ZXFV201, ZXFV202, ZXFV203, ZXFV204

Pinout details

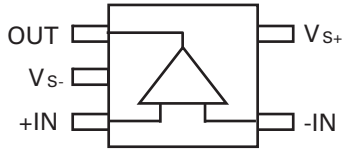

ZXFV202E5
Single

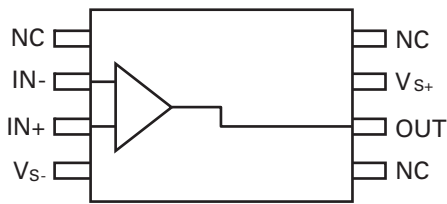

ZXFV202N8
Single

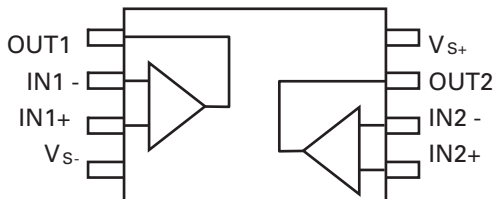

ZXFV204
Dual

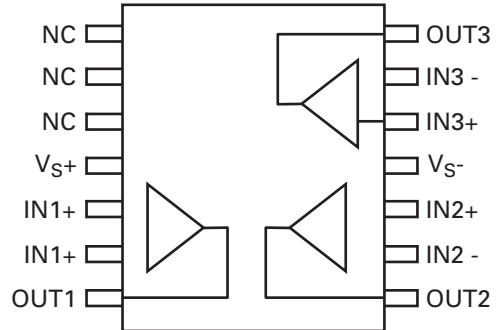

ZXFV203
Triple

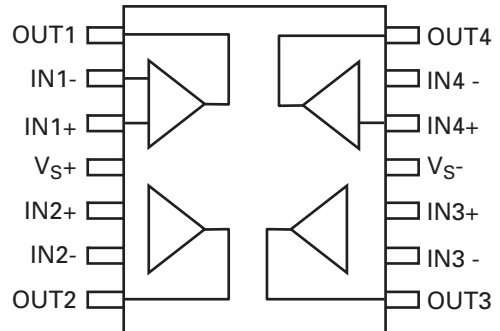

ZXFV201
Quad

ZXFV201, ZXFV202, ZXFV203, ZXFV204

Package details - SO8, SO14

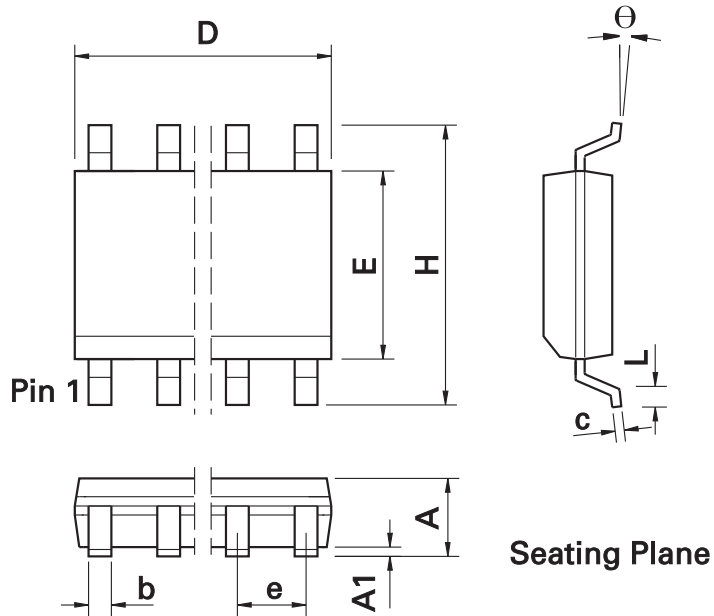

Dim.	Inches		Millimeters		Dim.	Inches		Millimeters	
	Min.	Max.	Min.	Max.		Min.	Max.	Min.	Max.
A	0.053	0.069	1.35	1.75	L	0.016	0.050	0.40	1.27
A1	0.004	0.010	0.10	0.25	e	0.050 BSC		1.27 BSC	
D (8 pin)	0.189	0.197	4.80	5.00	b	0.013	0.020	0.33	0.51
D (14 pin)	0.337	0.344	8.55	8.75	c	0.008	0.010	0.19	0.25
H	0.228	0.244	5.80	6.20	Θ	0°	8°	0°	8°
E	0.150	0.157	3.80	4.00	h	0.010	0.020	0.25	0.50

Note: Controlling dimensions are in inches. Approximate dimensions are provided in millimeters

ZXFV201, ZXFV202, ZXFV203, ZXFV204

Package outline - SOT23

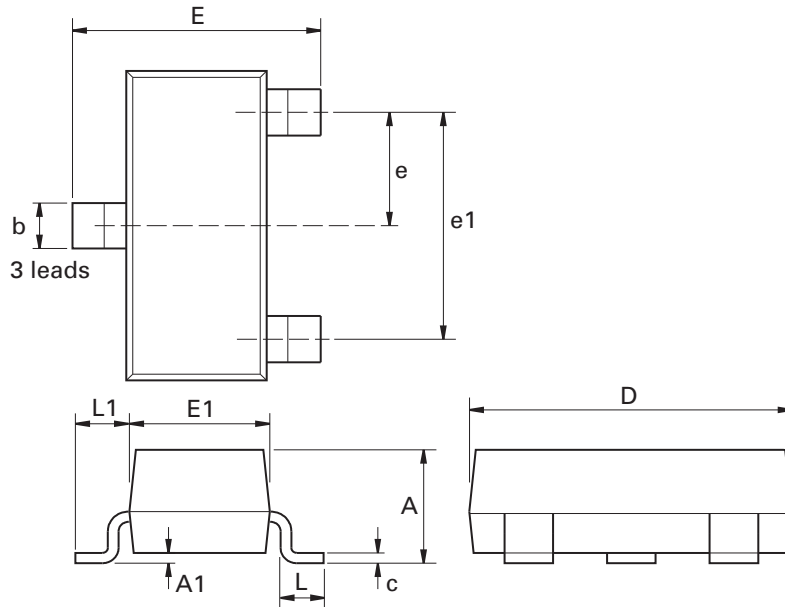

Dim.	Millimeters		Inches		Dim.	Millimeters		Inches	
	Min.	Max.	Min.	Max.		Min.	Max.	Max.	Max.
A	-	1.12	-	0.044	e1	1.90 NOM		0.075 NOM	
A1	0.01	0.10	0.0004	0.004	E	2.10	2.64	0.083	0.104
b	0.30	0.50	0.012	0.020	E1	1.20	1.40	0.047	0.055
C	0.085	0.120	0.003	0.008	L	0.25	0.62	0.018	0.024
D	2.80	3.04	0.110	0.120	L1	0.45	0.62	0.018	0.024
e	0.95 NOM		0.0375 NOM		-	-	-	-	-

Note: Controlling dimensions are in millimeters. Approximate dimensions are provided in inches

ZXFV201, ZXFV202, ZXFV203, ZXFV204

Definitions

Product change

Zetex Semiconductors reserves the right to alter, without notice, specifications, design, price or conditions of supply of any product or service. Customers are solely responsible for obtaining the latest relevant information before placing orders.

Applications disclaimer

The circuits in this design/application note are offered as design ideas. It is the responsibility of the user to ensure that the circuit is fit for the user's application and meets with the user's requirements. No representation or warranty is given and no liability whatsoever is assumed by Zetex with respect to the accuracy or use of such information, or infringement of patents or other intellectual property rights arising from such use or otherwise. Zetex does not assume any legal responsibility or will not be held legally liable (whether in contract, tort (including negligence), breach of statutory duty, restriction or otherwise) for any damages, loss of profit, business, contract, opportunity or consequential loss in the use of these circuit applications, under any circumstances.

Life support

Zetex products are specifically not authorized for use as critical components in life support devices or systems without the express written approval of the Chief Executive Officer of Zetex Semiconductors plc. As used herein:

A. Life support devices or systems are devices or systems which:

1. are intended to implant into the body

or

2. support or sustain life and whose failure to perform when properly used in accordance with instructions for use provided in the labelling can be reasonably expected to result in significant injury to the user.

B. A critical component is any component in a life support device or system whose failure to perform can be reasonably expected to cause the failure of the life support device or to affect its safety or effectiveness.

Reproduction

The product specifications contained in this publication are issued to provide outline information only which (unless agreed by the company in writing) may not be used, applied or reproduced for any purpose or form part of any order or contract or be regarded as a representation relating to the products or services concerned.

Terms and Conditions

All products are sold subjects to Zetex' terms and conditions of sale, and this disclaimer (save in the event of a conflict between the two when the terms of the contract shall prevail) according to region, supplied at the time of order acknowledgement.

For the latest information on technology, delivery terms and conditions and prices, please contact your nearest Zetex sales office.

Quality of product

Zetex is an ISO 9001 and TS16949 certified semiconductor manufacturer.

To ensure quality of service and products we strongly advise the purchase of parts directly from Zetex Semiconductors or one of our regionally authorized distributors. For a complete listing of authorized distributors please visit: www.zetex.com/salesnetwork

Zetex Semiconductors does not warrant or accept any liability whatsoever in respect of any parts purchased through unauthorized sales channels.

ESD (Electrostatic discharge)

Semiconductor devices are susceptible to damage by ESD. Suitable precautions should be taken when handling and transporting devices. The possible damage to devices depends on the circumstances of the handling and transporting, and the nature of the device. The extent of damage can vary from immediate functional or parametric malfunction to degradation of function or performance in use over time. Devices suspected of being affected should be replaced.

Green compliance

Zetex Semiconductors is committed to environmental excellence in all aspects of its operations which includes meeting or exceeding regulatory requirements with respect to the use of hazardous substances. Numerous successful programs have been implemented to reduce the use of hazardous substances and/or emissions.

All Zetex components are compliant with the RoHS directive, and through this it is supporting its customers in their compliance with WEEE and ELV directives.

Product status key:

"Preview"	Future device intended for production at some point. Samples may be available
"Active"	Product status recommended for new designs
"Last time buy (LTB)"	Device will be discontinued and last time buy period and delivery is in effect
"Not recommended for new designs"	Device is still in production to support existing designs and production
"Obsolete"	Production has been discontinued

Datasheet status key:

"Draft version"	This term denotes a very early datasheet version and contains highly provisional information, which may change in any manner without notice.
"Provisional version"	This term denotes a pre-release datasheet. It provides a clear indication of anticipated performance. However, changes to the test conditions and specifications may occur, at any time and without notice.
"Issue"	This term denotes an issued datasheet containing finalized specifications. However, changes to specifications may occur, at any time and without notice.

Zetex sales offices

Europe	Americas	Asia Pacific	Corporate Headquarters
Zetex GmbH Kustermann-park Balanstraße 59 D-81541 München Germany Telephone: (49) 89 45 49 49 0 Fax: (49) 89 45 49 49 49 europe.sales@zetex.com	Zetex Inc 700 Veterans Memorial Highway Hauppauge, NY 11788 USA Telephone: (1) 631 360 2222 Fax: (1) 631 360 8222 usa.sales@zetex.com	Zetex (Asia Ltd) 3701-04 Metroplaza Tower 1 Hing Fong Road, Kwai Fong Hong Kong Telephone: (852) 26100 611 Fax: (852) 24250 494 asia.sales@zetex.com	Zetex Semiconductors plc Zetex Technology Park, Chadderton Oldham, OL9 9LL United Kingdom Telephone: (44) 161 622 4444 Fax: (44) 161 622 4446 hq@zetex.com

© 2007 Published by Zetex Semiconductors plc

Looking for pricing, stock, or lifecycle information?

Click below to explore more details on WIN SOURCE:

-  [View ZXFV202E5TA on WIN SOURCE](#)
-  [Diodes Incorporated Information](#)

Optimize Your Supply Chain with WIN SOURCE Solutions

-  Global Sourcing Solution
-  Obsolete Management
-  Cost Control Management
-  Shortage Management
-  Alternative Solution
-  Excess Inventory Management