



**THE DATASHEET OF
TPS2819MDBVREP**



SINGLE-CHANNEL HIGH-SPEED MOSFET DRIVER

FEATURES

- **Controlled Baseline**
 - One Assembly Site
 - One Test Site
 - One Fabrication Site
- **Extended Temperature Performance of –55°C to 125°C**
- **Enhanced Diminishing Manufacturing Sources (DMS) Support**
- **Enhanced Product-Change Notification**
- **Qualification Pedigree ⁽¹⁾**
- **Low-Cost Single-Channel High-Speed MOSFET Driver**
- **I_{CC} . . . 15 μA Max (TPS2828, TPS2829)**
- **25 ns Max Rise/Fall Times and 40 ns Max Propagation Delay . . . 1 nF Load**
- **2 A Peak Output Current**
- **4 V to 14 V Driver Supply Voltage Range; Internal Regulator Extends Range to 40 V (TPS2816, TPS2817, TPS2818, TPS2819)**
- **5-pin SOT-23 Package**
- **–55°C to 125°C Ambient-Temperature Operating Range**
- **Highly Resistant to Latch-ups**

(1) Component qualification in accordance with JEDEC and industry standards to ensure reliable operation over an extended temperature range. This includes, but is not limited to, Highly Accelerated Stress Test (HAST) or biased 85/85, temperature cycle, autoclave or unbiased HAST, electromigration, bond intermetallic life, and mold compound life. Such qualification testing should not be viewed as justifying use of this component beyond specified performance and environmental limits.

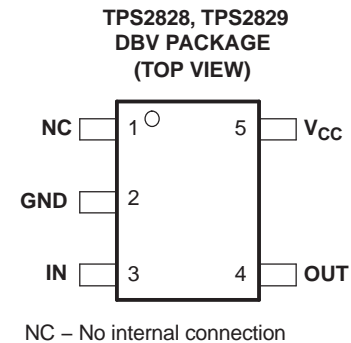
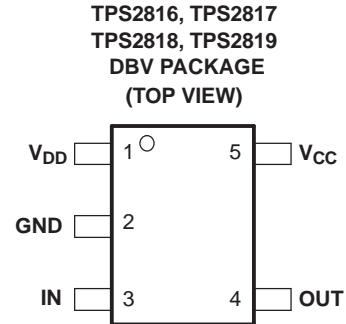

DESCRIPTION/ORDERING INFORMATION

The TPS28xx single-channel high-speed MOSFET drivers are capable of delivering peak currents of up to 2 A into highly capacitive loads. High switching speeds (t_r and $t_f = 14$ ns typ) are obtained with the use of BiCMOS outputs. Typical threshold switching voltages are 2/3 and 1/3 of V_{CC} . The design inherently minimizes shoot-through current.



Please be aware that an important notice concerning availability, standard warranty, and use in critical applications of Texas Instruments semiconductor products and disclaimers thereto appears at the end of this data sheet.

A regulator is provided on TPS2816 through TPS2819 devices to allow operation with supply inputs between 14 V and 40 V. The regulator output can be used to power other circuits, provided power dissipation does not exceed package limitations. If the regulator is not required, V_{DD} (the regulator input) should be connected to V_{CC} . The TPS2816 and TPS2817 input circuits include an active pullup circuit to eliminate the need for an external resistor when using open-collector PWM controllers. The TPS2818 and TPS2819 are identical to the TPS2816 and TPS2817, except that the active pullup circuit is omitted. The TPS2828 and TPS2829 are identical to the TPS2818 and TPS2819, except that the internal voltage regulator is omitted, allowing quiescent current to drop to less than 15 μ A when the inputs are high or low.

The TPS28xx series devices are available in 5-pin SOT-23 (DBV) packages and operate over an ambient temperature range of -55°C to 125°C .

AVAILABLE OPTIONS⁽¹⁾

T_A	FUNCTION	PACKAGED DEVICES	SYMBOL	CHIP FORM (Y)	PACKAGE ORDER
		SOT-23-5 (DBV) ⁽²⁾⁽³⁾			
-55°C to 125°C	Inverting driver with active pullup input	TPS2816DBV ⁽⁴⁾	TBD	TPS2816Y	TPS2816MDBVREP
	Noninverting driver with active pullup input	TPS2817DBV ⁽⁴⁾	TBD	TPS2817Y	TPS2817MDBVREP
	Inverting driver	TPS2818DBV	PMTM	TPS2818Y	TPS2818MDBVREP
	Noninverting driver	TPS2819DBV	PMUM	TPS2819Y	TPS2819MDBVREP
	Inverting driver, no regulator	TPS2828DBV ⁽⁴⁾	TBD	TPS2828Y	TPS2828MDBVREP
	Noninverting driver, no regulator	TPS2829DBV ⁽⁴⁾	TBD	TPS2829Y	TPS2829MDBVREP

(1) For the most current package and ordering information, see the Package Option Addendum at the end of this document, or see the TI website at www.ti.com.

(2) Package drawings, thermal data, and symbolization are available at www.ti.com/packaging.

(3) The DBV package is available taped and reeled only.

(4) Product Preview

FUNCTIONAL BLOCK DIAGRAM

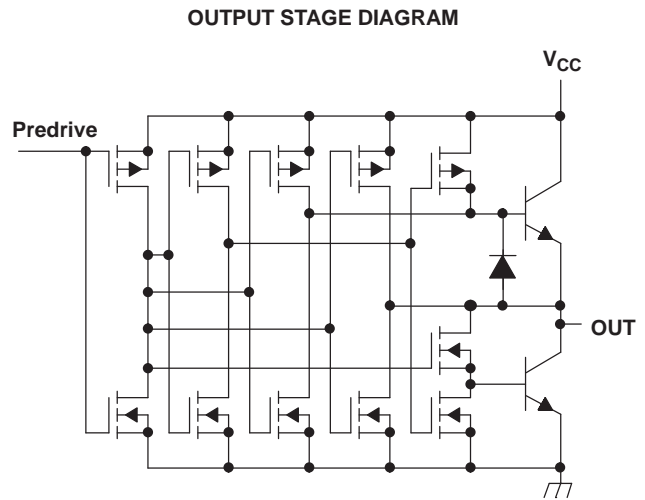
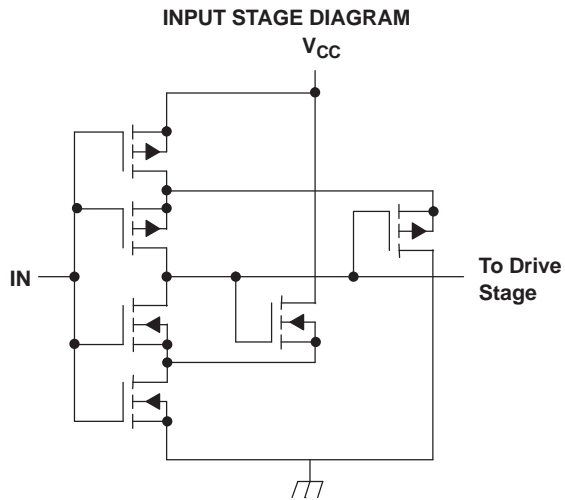
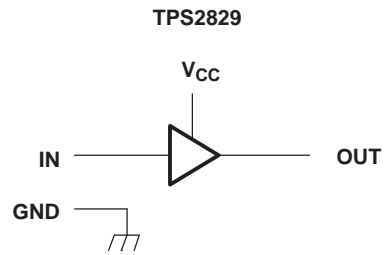
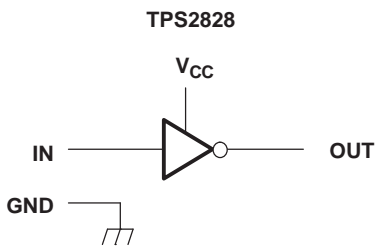
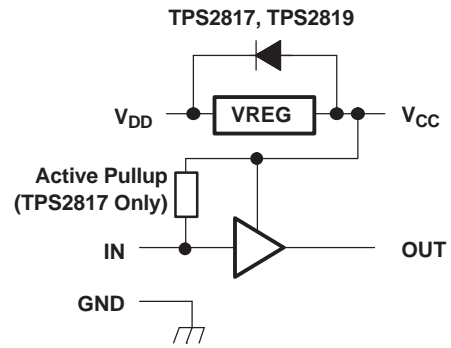
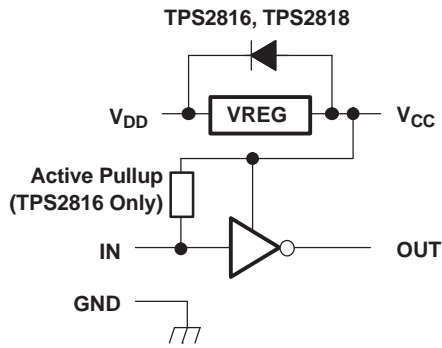

TPS28xxY Chip Information

This chip, when properly assembled, displays characteristics similar to those of the TPS28xx. Thermal compression or ultrasonic bonding may be used on the doped aluminum bonding pads. The chip may be mounted with conductive epoxy or a gold-silicon preform.

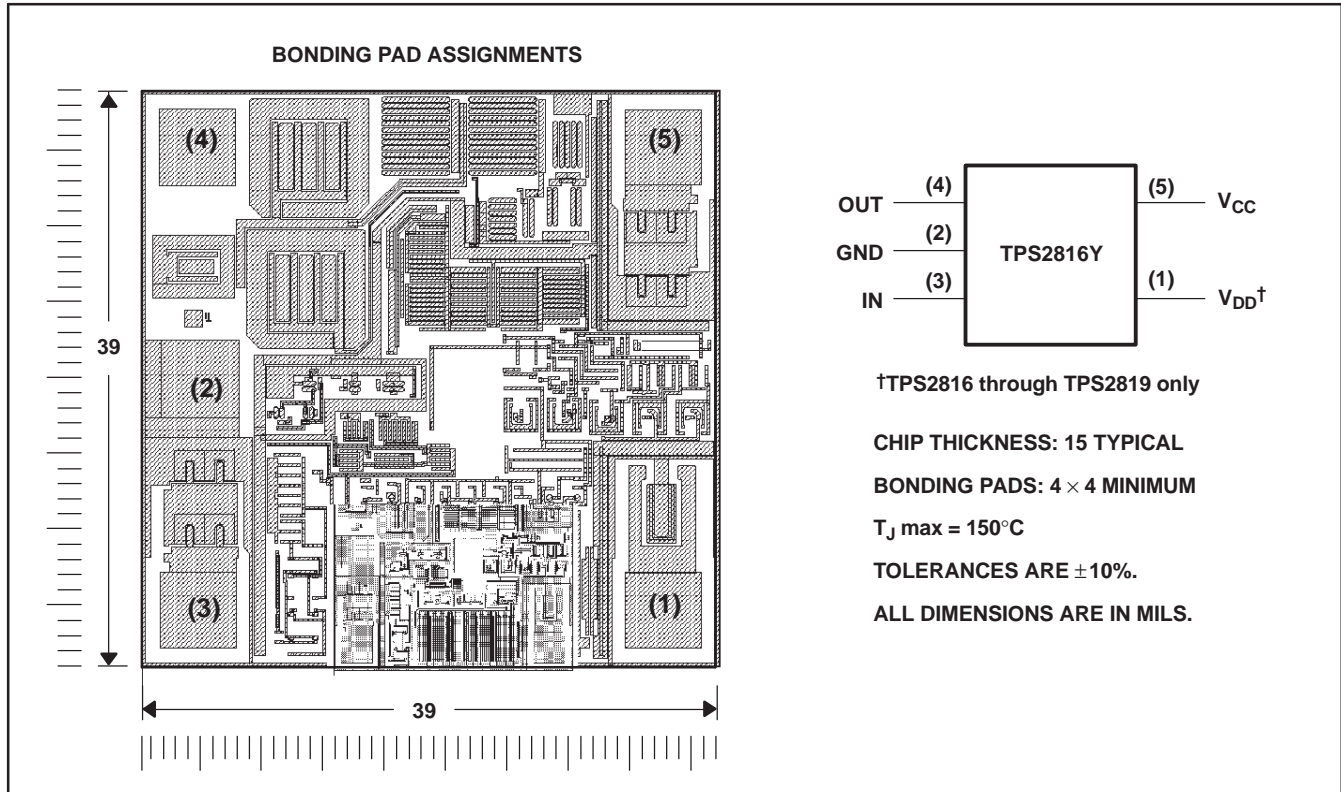

TERMINAL FUNCTIONS TPS2816, TPS2818, TPS2828 (Inverting Driver)

TERMINAL		DESCRIPTION
NAME	NO.	
V_{DD}	1	Regulator supply voltage input. (Not connected on TPS2828)
GND	2	Ground
IN	3	Driver input.
OUT	4	Driver output, $\text{OUT} = \overline{\text{IN}}$
V_{CC}	5	Driver supply voltage/regulator output voltage

TERMINAL FUNCTIONS TPS2817, TPS2819, TPS2829 (Noninverting Driver)

TERMINAL		DESCRIPTION
NAME	NO.	
V_{DD}	1	Regulator supply voltage input. (Not connected on TPS2829)
GND	2	Ground
IN	3	Driver input.
OUT	4	Driver output, $\text{OUT} = \text{IN}$
V_{CC}	5	Driver supply voltage/regulator output voltage

DISSIPATION RATING TABLE⁽¹⁾

PACKAGE	T _A ≤ 25°C POWER RATING	DERATING FACTOR ABOVE T _A = 25°C	T _A = 70°C POWER RATING	T _A = 80°C POWER RATING
DBV	437 mW	3.5 mW/°C	280 mW	227 mW

(1) These dissipation ratings are based upon EIA specification JESD51-3, "Low Effective Thermal Conductivity Test Board for Leaded Surface Mount Packages," in tests conducted in a zero-airflow, wind tunnel environment.

ABSOLUTE MAXIMUM RATINGS⁽¹⁾

over operating free-air temperature range (unless otherwise noted)

	VALUE	UNIT
V _{CC} Supply voltage range ⁽²⁾	–0.3 to 15	V
V _{DD} Regulator supply voltage range ⁽²⁾	V _{CC} – 0.3 to 42	V
IN Input voltage range ⁽²⁾	–0.3 to V _{CC} + 0.5	V
Output voltage range (pin 4) ⁽²⁾	–0.5 to V _{CC} + 0.5	V
V _{CC} Continuous regulator output current	25	mA
OUT Continuous output current	±100	mA
Continuous total power dissipation	See Dissipation Rating Table	
T _A Operating ambient temperature range	–55 to 125	°C
T _{stg} Storage temperature range	–65 to 150	°C
Lead temperature 1,6 mm (1/16 inch) from case for 10 seconds	260	°C

(1) Stresses beyond those listed under "absolute maximum ratings" may cause permanent damage to the device. These are stress ratings only, and functional operation of the device at these or any other conditions beyond those indicated under "recommended operating conditions" is not implied. Exposure to absolute-maximum-rated conditions for extended periods may affect device reliability.

(2) All voltages are with respect to device GND terminal.

RECOMMENDED OPERATING CONDITIONS

	MIN	MAX	UNIT
V _{DD} Regulator input voltage range, TPS2816 through TPS2819	8	40	V
V _{CC} Supply voltage	4	14	V
IN Input voltage	–0.3	V _{CC}	V
I _{CC} Continuous regulator output current	0	20	mA
T _A Operating ambient temperature range	–55	125	°C

TPS28xx ELECTRICAL CHARACTERISTICS

Inputs

over recommended operating ambient temperature range, $V_{CC} = 10\text{ V}$, V_{DD} tied to V_{CC} , $C_L = 1\text{ nF}$ (unless otherwise specified)

PARAMETER	TEST CONDITIONS	MIN	TYP ⁽¹⁾	MAX	UNIT
Positive-going input threshold voltage	$V_{CC} = 5\text{ V}$		3.3	4	V
	$V_{CC} = 10\text{ V}$		6.6	7	
	$V_{CC} = 14\text{ V}$		9.3	10	
Negative-going input threshold voltage	$V_{CC} = 5\text{ V}$	1	1.7		V
	$V_{CC} = 10\text{ V}$	2	3.3		
	$V_{CC} = 14\text{ V}$	2.5	4.6		
Input voltage hysteresis			1.3		V
Input current, TPS2818/19/28/29	Input = 0 V or V_{CC}		0.2		μA
Input current, TPS2816/17	Input = 0 V		650		μA
	Input = V_{CC}		15		
Input capacitance			5	10	pF

(1) Typical are for $T_A = 25^\circ\text{C}$ (unless otherwise noted).

Outputs

PARAMETER	TEST CONDITIONS	MIN	TYP ⁽¹⁾	MAX	UNIT
High-level output voltage	$I_O = -1\text{ mA}$	9.75	9.9		V
	$I_O = -100\text{ mA}$	8	9.1		
Low-level output voltage	$I_O = 1\text{ mA}$		0.18	0.25	V
	$I_O = 100\text{ mA}$		1	2	

(1) Typical are for $T_A = 25^\circ\text{C}$ (unless otherwise noted).

Regulator, TPS2816 Through TPS2819

PARAMETER	TEST CONDITIONS	MIN	TYP ⁽¹⁾	MAX	UNIT
Output voltage	$14 \leq V_{DD} \leq 40\text{ V}$, $0 \leq I_O \leq 20\text{ mA}$	10	11.5	13	V
Output voltage in dropout	$I_O = 10\text{ mA}$, $V_{DD} = 10\text{ V}$	8		10	V

(1) Typical are for $T_A = 25^\circ\text{C}$ (unless otherwise noted).

Supply Current

PARAMETER	TEST CONDITIONS	MIN	TYP ⁽¹⁾	MAX	UNIT
Supply current into V_{CC}	TPS2816, TPS2817	IN = high = 10 V	150	250	μA
		IN = low = 0 V	650	1000	
	TPS2818, TPS2819	IN = high or low, High = 10 V, Low = 0 V	25	55	
			0.1	15	
Supply current into V_{DD}	TPS2816, TPS2817	$V_{DD} = 20\text{ V}$, IN = high = 10 V or low = 0 V	650	1000	μA
	TPS2818, TPS2819	$V_{DD} = 20\text{ V}$, IN = high = 10 V or low = 0 V	50	400	

(1) Typical are for $T_A = 25^\circ\text{C}$ (unless otherwise noted).

TPS28xxY ELECTRICAL CHARACTERISTICS

Inputs

over recommended operating ambient temperature range, $V_{CC} = 10\text{ V}$, V_{DD} tied to V_{CC} , $C_L = 1\text{ nF}$ (unless otherwise specified)

PARAMETER	TEST CONDITIONS	MIN	TYP ⁽¹⁾	MAX	UNIT
Positive-going input threshold voltage	$V_{CC} = 5\text{ V}$		3.3		V
	$V_{CC} = 10\text{ V}$		6.6		
	$V_{CC} = 14\text{ V}$		9.3		
Negative-going input threshold voltage	$V_{CC} = 5\text{ V}$		1.7		V
	$V_{CC} = 10\text{ V}$		3.3		
	$V_{CC} = 14\text{ V}$		4.6		
Input voltage hysteresis			1.3		V
Input current, TPS2818/19/28/29	Input = 0 V or V_{CC}		0.2		μA
Input current, TPS2816/17	Input = 0 V		650		μA
	Input = V_{CC}		15		
Input resistance			1000		$\text{M}\Omega$
Input capacitance			5		pF

(1) Typical are for $T_A = 25^\circ\text{C}$ (unless otherwise noted).

Outputs

PARAMETER	TEST CONDITIONS	MIN	TYP ⁽¹⁾	MAX	UNIT
High-level output voltage	$I_O = -1\text{ mA}$		9.9		V
	$I_O = -100\text{ mA}$		9.1		
Low-level output voltage	$I_O = 1\text{ mA}$		0.18		V
	$I_O = 100\text{ mA}$		1		

(1) Typical are for $T_A = 25^\circ\text{C}$ (unless otherwise noted).

Regulator, TPS2816 Through TPS2819

PARAMETER	TEST CONDITIONS	MIN	TYP ⁽¹⁾	MAX	UNIT
Output voltage	$14 \leq V_{DD} \leq 40\text{ V}$, $0 \leq I_O \leq 20\text{ mA}$		11.5		V
Output voltage in dropout	$I_O = 10\text{ mA}$, $V_{DD} = 10\text{ V}$		9		V

(1) Typical are for $T_A = 25^\circ\text{C}$ (unless otherwise noted).

Supply Current

PARAMETER		TEST CONDITIONS	MIN	TYP ⁽¹⁾	MAX	UNIT
Supply current into V_{CC}	TPS2816, TPS2817	IN = high = 10 V		150		μA
		IN = low = 0 V		650		
	TPS2818, TPS2819	IN = high or low, High = 10 V, Low = 0 V		25		
				0.1		
Supply current into V_{DD}	TPS2816, TPS2817	$V_{DD} = 20\text{ V}$, IN = high = 10 V or low = 0 V		650		μA
	TPS2818, TPS2819	$V_{DD} = 20\text{ V}$, IN = high = 10 V or low = 0 V		50		

(1) Typical are for $T_A = 25^\circ\text{C}$ (unless otherwise noted).

SWITCHING CHARACTERISTICS

for all devices over recommended operating ambient temperature range, $V_{CC} = 10\text{ V}$, V_{DD} tied to V_{CC} , $C_L = 1\text{ nF}$
 (unless otherwise specified)

PARAMETER		TEST CONDITIONS	MIN	TYP	MAX	UNIT
t_r	Rise time	$V_{CC} = 14\text{ V}$			25	ns
		$V_{CC} = 10\text{ V}$		14	30	
		$V_{CC} = 5\text{ V}$			35	
t_f	Fall time	$V_{CC} = 14\text{ V}$			25	ns
		$V_{CC} = 10\text{ V}$		14	30	
		$V_{CC} = 5\text{ V}$			35	
t_{PHL}	Propagation delay time, high-to-low-level output	$V_{CC} = 14\text{ V}$			40	ns
		$V_{CC} = 10\text{ V}$		24	45	
		$V_{CC} = 5\text{ V}$			50	
t_{PLH}	Propagation delay time, low-to-high-level output	$V_{CC} = 14\text{ V}$			40	ns
		$V_{CC} = 10\text{ V}$		24	45	
		$V_{CC} = 5\text{ V}$			50	

PARAMETER MEASUREMENT INFORMATION

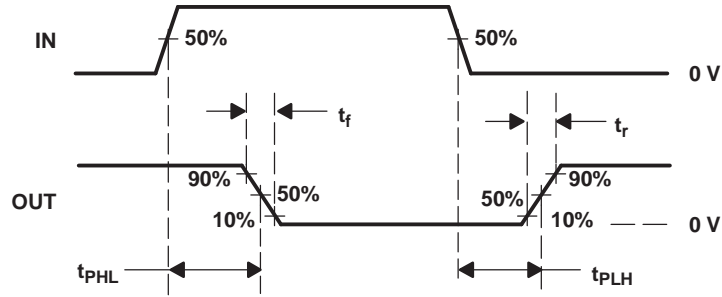

Figure 1. Typical Timing Diagram (TPS2816)

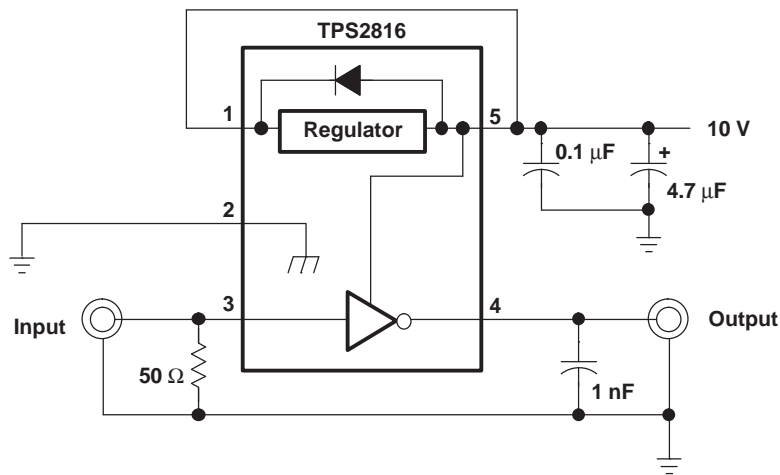

Figure 2. Switching Time Test Setup

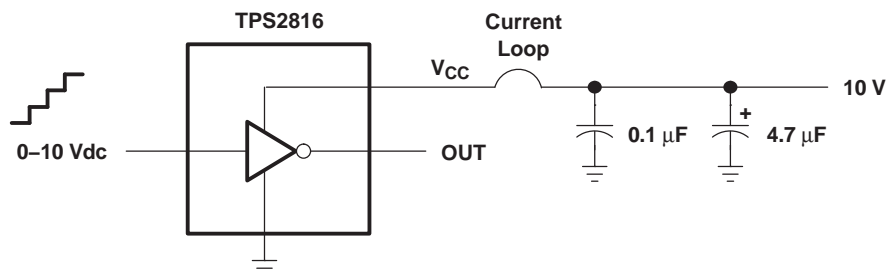

Figure 3. Shoot-Through Current Test Setup

TYPICAL CHARACTERISTICS

Table of Graphs

		FIGURE
Rise time	vs Supply voltage	4
Fall time	vs Supply voltage	5
Propagation time (L > H)	vs Supply voltage	6
Propagation Time (H > L)	vs Supply voltage	7
Rise time	vs Ambient temperature	8
Fall time	vs Ambient temperature	9
Propagation time (L > H)	vs Supply voltage	10
Propagation time (H > L)	vs Ambient temperature	11
Supply current (V_{CC})	vs Supply voltage	12
Supply current (V_{CC})	vs Load capacitance	13
Supply current (V_{CC})	vs Ambient temperature	14
Input threshold voltage	vs Supply voltage	15
Regulator output voltage	vs Regulator supply voltage	16
Regulator quiescent current	vs Regulator supply voltage	17
Shoot-through current	vs Input voltage (L > H)	18
Shoot-through current	vs Input voltage (H > L)	19

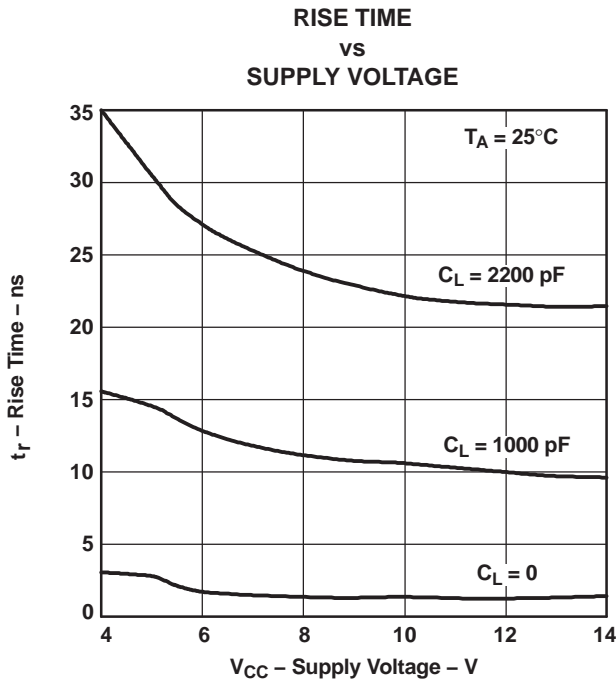

Figure 4.

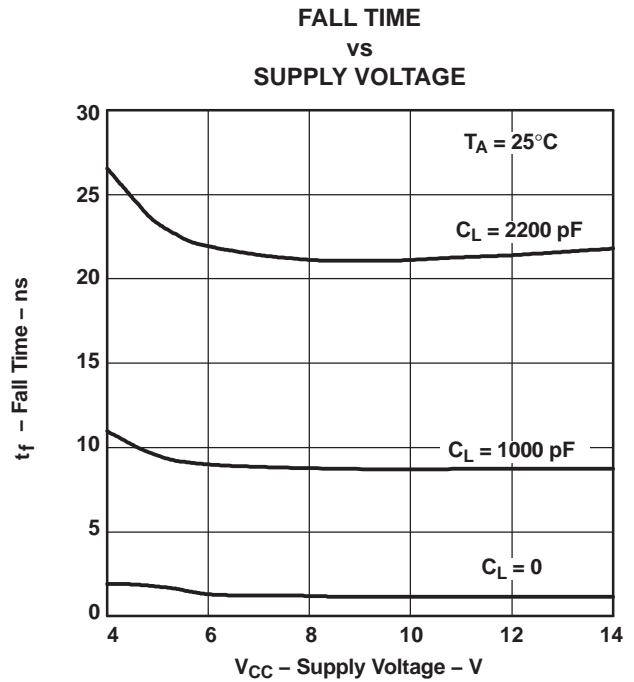

Figure 5.

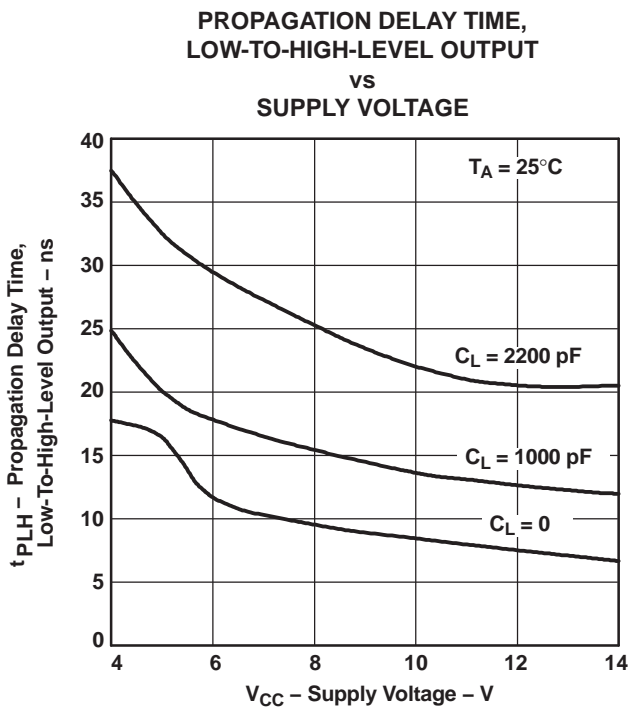

Figure 6.

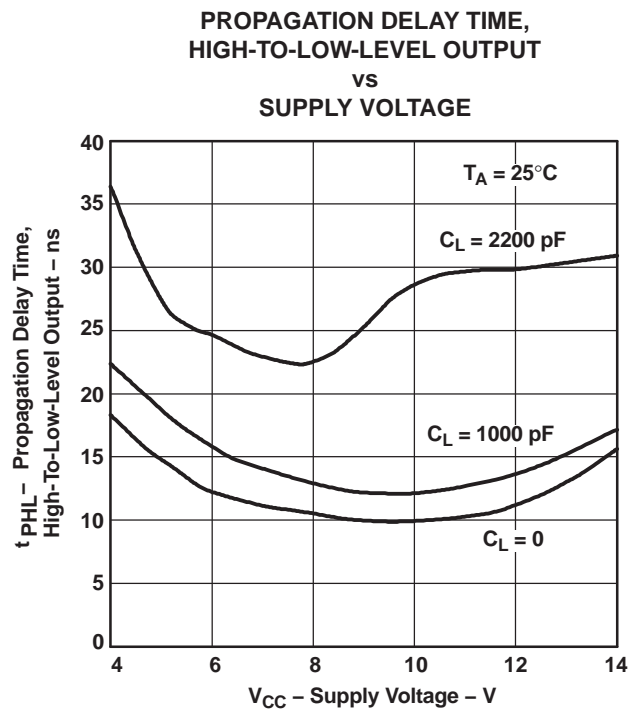

Figure 7.

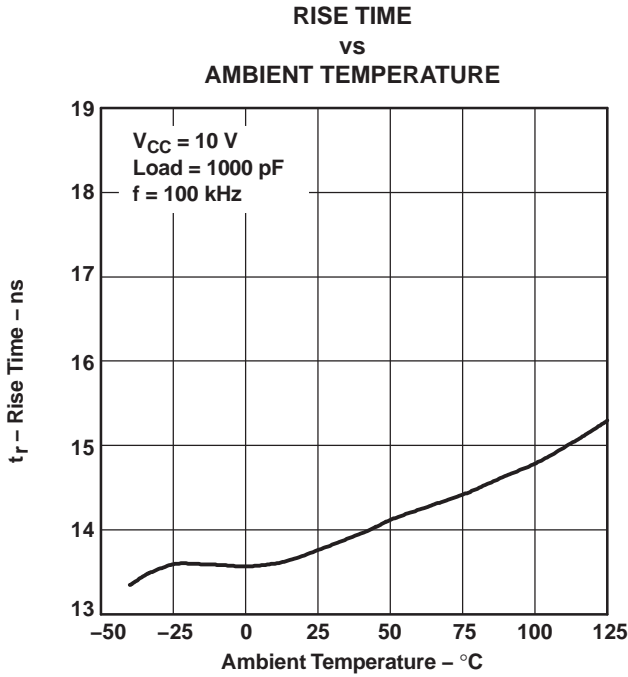

Figure 8.

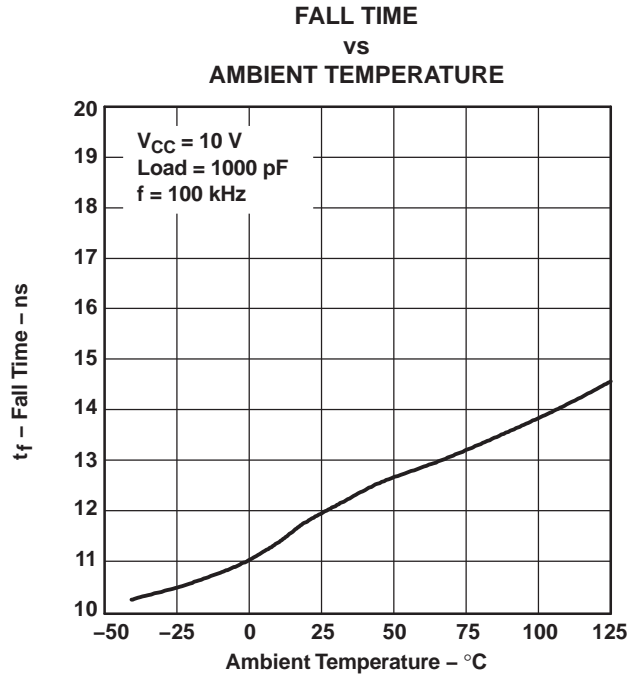

Figure 9.

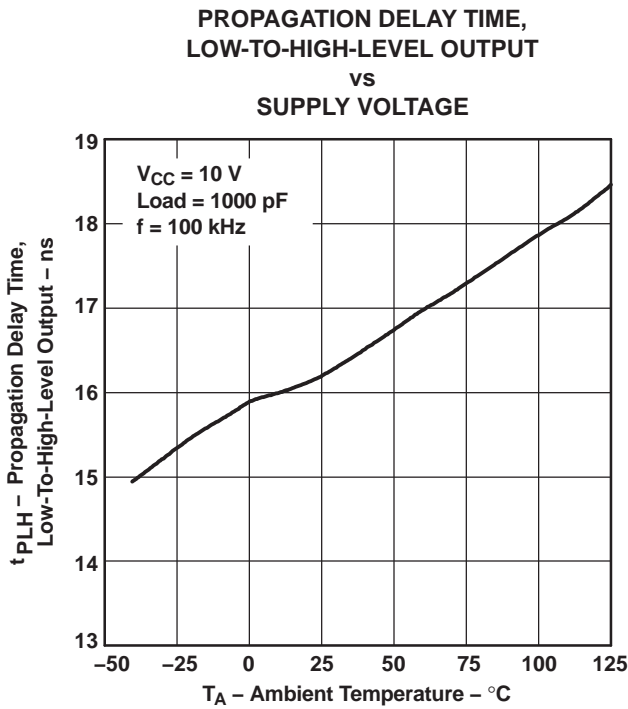

Figure 10.

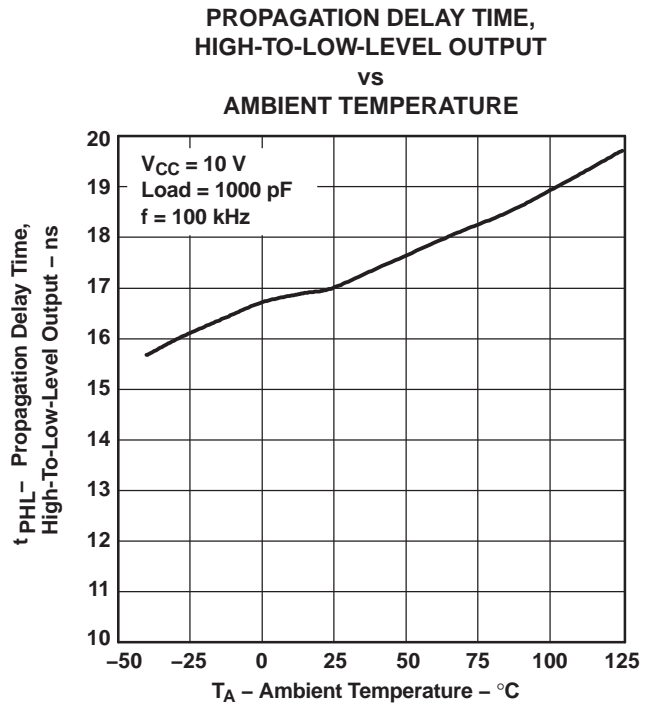

Figure 11.

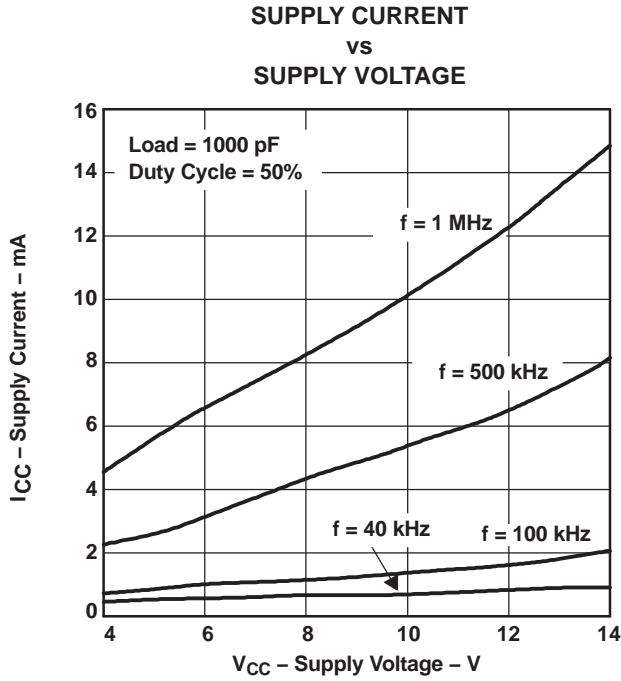

Figure 12.

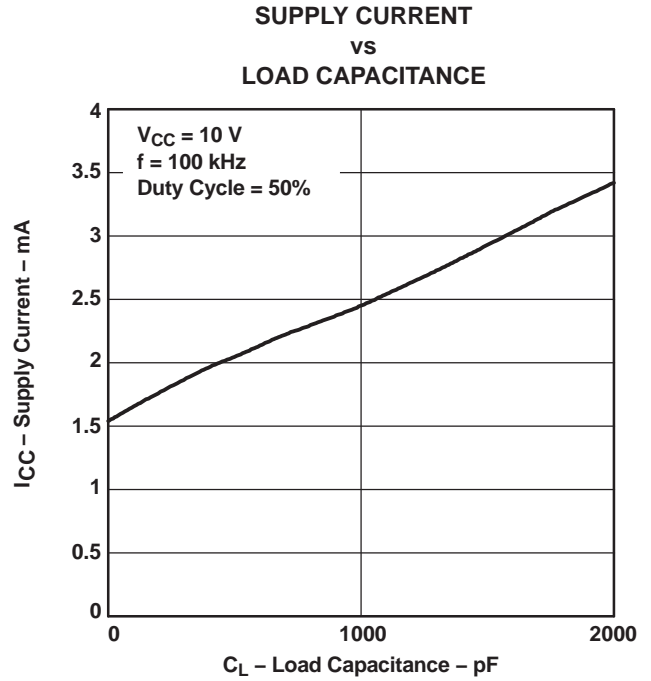

Figure 13.

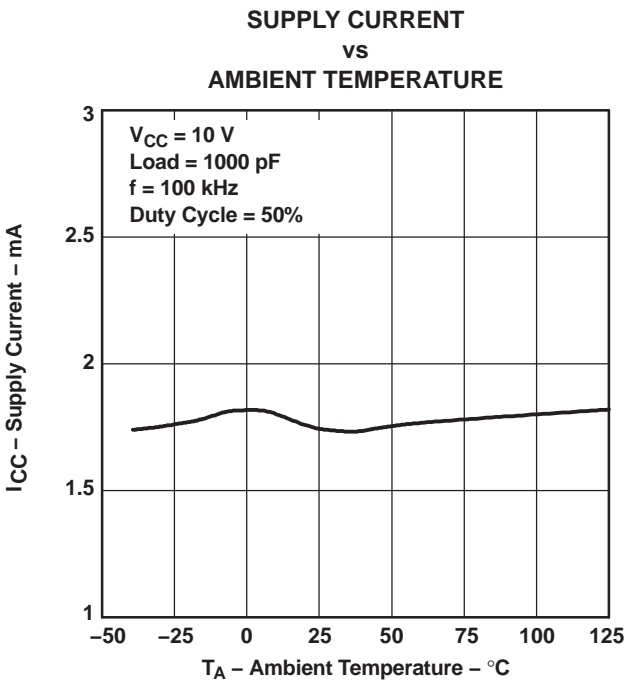

Figure 14.

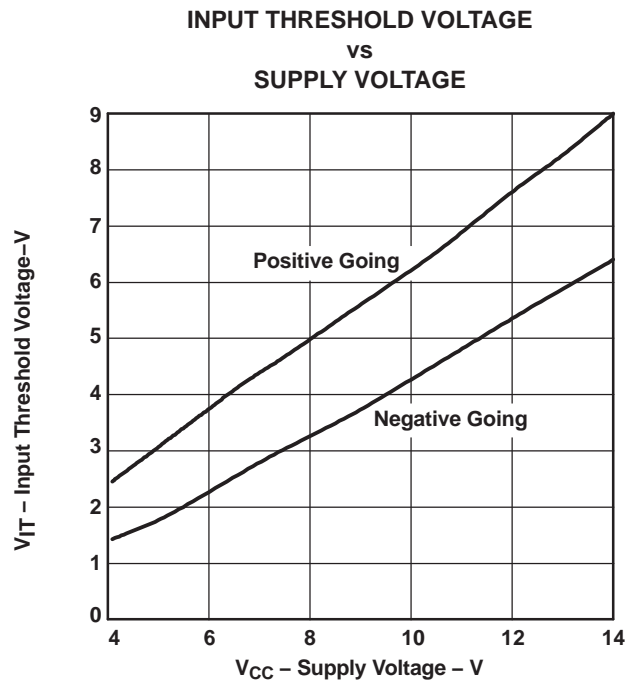
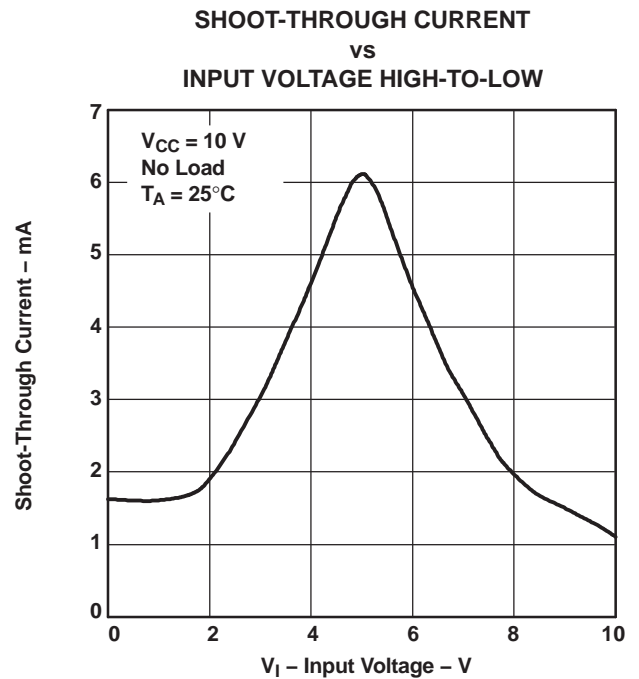
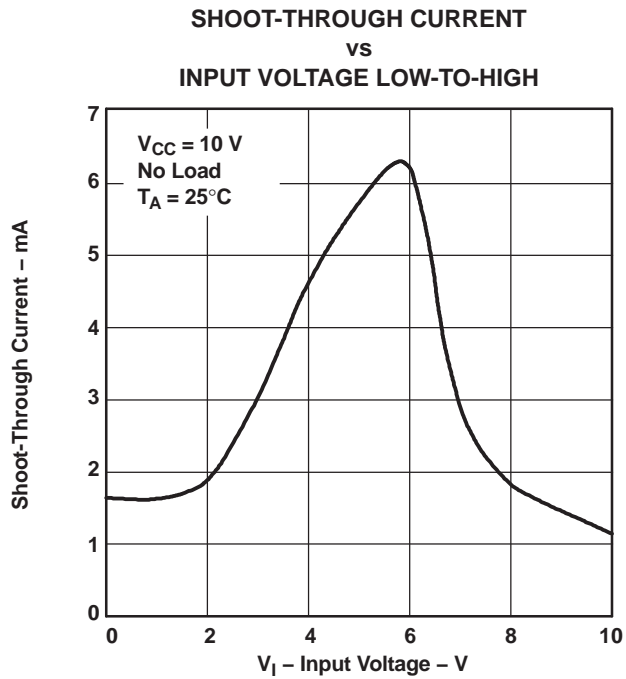
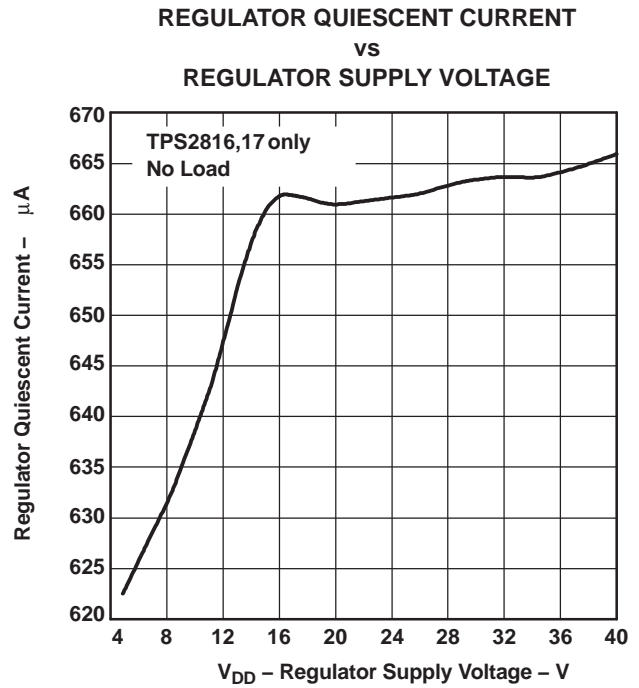
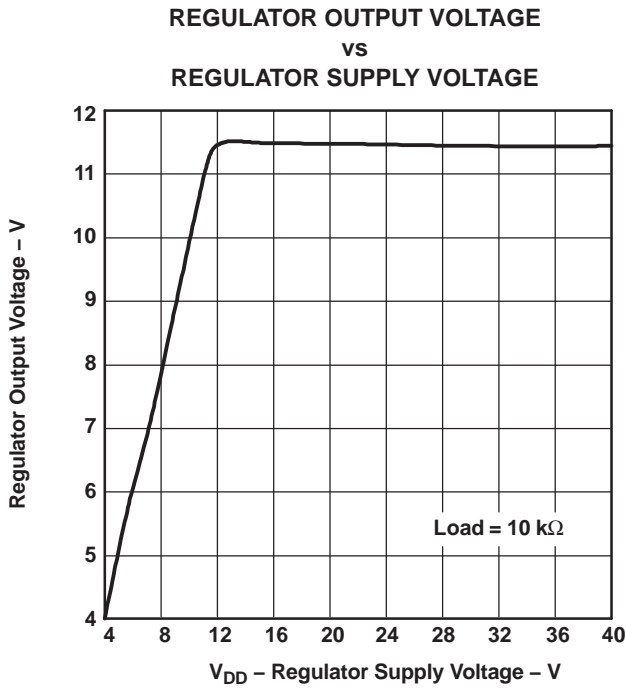

Figure 15.



APPLICATION INFORMATION

MOSFETs are voltage-driven devices that require very little steady-state drive current. However, the large input capacitance (200 pF to 3000 pF or greater) of these devices requires large current surges to reduce the turn-on and turn-off times. The TPS2816 series of high-speed drivers can supply up to 2 A to a MOSFET, greatly reducing the switching times. The fast rise times and fall times and short propagation delays allow for operation in today's high-frequency switching converters.

In addition, MOSFETs have a limited gate-bias voltage range, usually less than 20 V. The TPS2816 series of drivers extends this operating range by incorporating an on-board series regulator with an input range up to 40 V. This regulator can be used to power the drivers, the PWM chip, and other circuitry, providing the power dissipation rating is not exceeded.

When using these devices, care should be exercised in the proper placement of the driver, the switching MOSFET, and the bypass capacitor. Because of the large input capacitance of the MOSFET, the driver should be placed close to the gate to eliminate the possibility of oscillations caused by trace inductance ringing with the gate capacitance of the MOSFET. When the driver output path is longer than approximately 2 inches, a resistor in the range of 10 Ω should be placed in series with the gate drive as close as possible to the MOSFET. A ceramic bypass capacitor is also recommended to provide a source for the high-speed current transients that the MOSFET requires. This capacitor should be placed between V_{CC} and GND of the driver (see [Figure 20](#) and [Figure 21](#)).

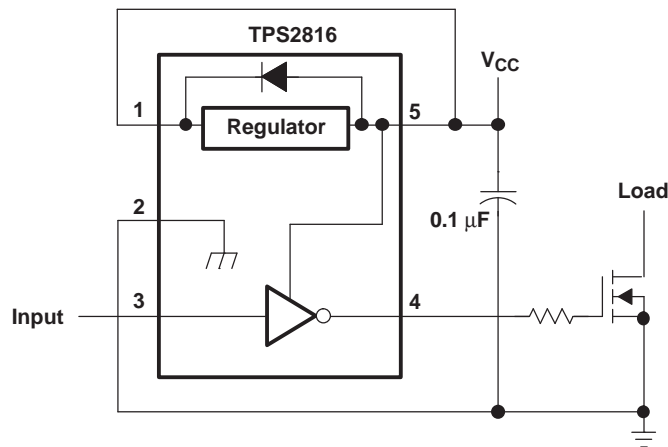

Figure 20. $V_{CC} < 14\text{ V}$

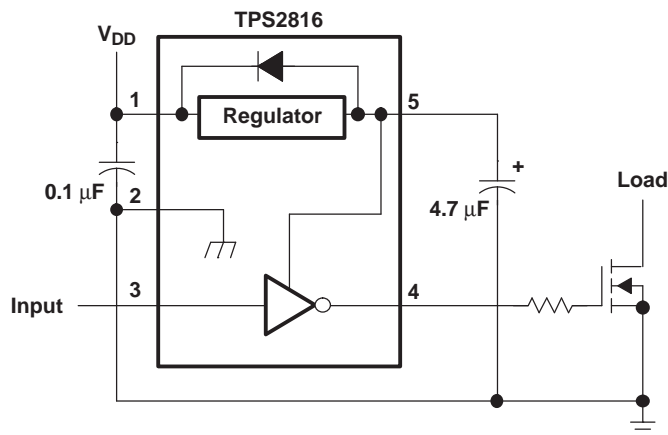

Figure 21. $V_{CC} > 14\text{ V}$

The on-board series regulator supplies approximately 20 mA of current at 11.5 V, some of which can be used for

external circuitry, providing the power dissipation rating for the driver is not exceeded. When using the on-board series regulator, an electrolytic output capacitor of 4.7 μF or larger is recommended. Although not required, a 0.1 μF ceramic capacitor on the input of the regulator can help suppress transient currents (see Figure 22). When not used, the regulator should be connected to V_{CC} . Grounding V_{DD} will result in destruction of the regulator.

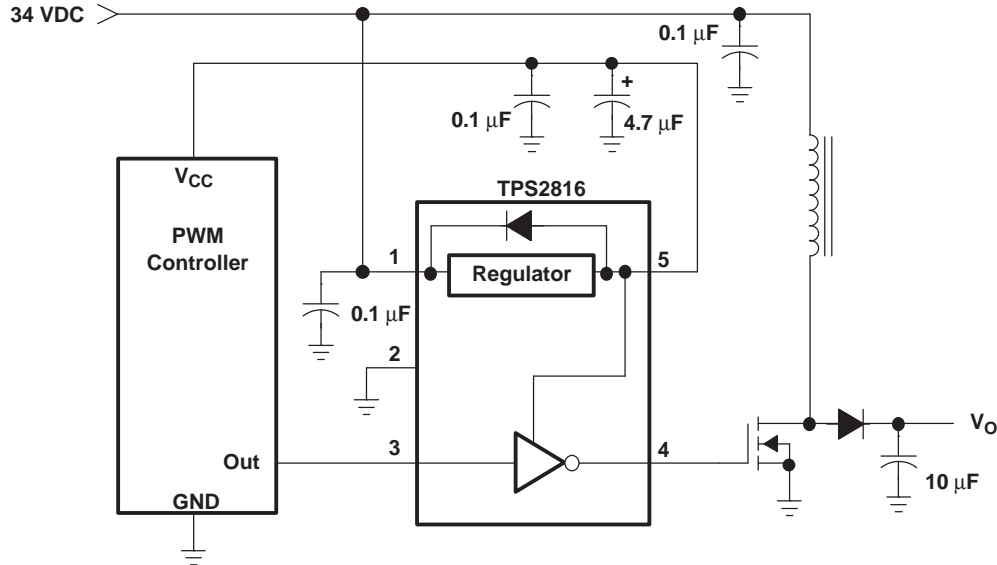

Figure 22. Boost Application

The TPS2816 and TPS2818 drivers include active pullup circuits on the inputs to eliminate the need for external pullup resistors when using controllers with open-collector outputs (such as the TL5001). The TPS2817 and TPS2819 drivers have standard CMOS inputs providing a total device operating current of less than 50 μA . All devices switch at standard CMOS logic levels of approximately $2/3 V_{\text{CC}}$ with positive-going input levels, and approximately $1/3 V_{\text{CC}}$ with negative-going input levels. Being CMOS drivers, these devices will draw relatively large amounts of current (Approximately 5 mA) when the inputs are in the range of one-half of the supply voltage. In normal operation, the driver input is in this range for a very short time. Care should be taken to avoid use of very low slew-rate inputs, used under normal operating conditions. Although not destructive to the device, slew rates slower than 0.1 $\text{V}/\mu\text{s}$ are not recommended.

The BiCMOS output stage provides high instantaneous drive current to rapidly toggle the power switch, and very low drop to each rail to ensure proper operation at voltage extremes.

Low-voltage circuits (less than 14 V) that require very low quiescent currents can use the TPS2828 and TPS2829 drivers. These drivers use typically 0.2 μA of quiescent current (with inputs high or low). They do not have the internal regulator or the active pullup circuit, but all other specifications are the same as for the rest of the family.

2.5-V/3.3-V, 3-A Application

Figure 23 illustrates the use of the TPS2817 with a TL5001 PWM controller and a TPS1110 in a simple step-down converter application. The converter operates at 275 kHz and delivers either 2.5 V or 3.3 V (determined by the value of R6) at 3 A (5 A peak) from a 5-V supply. The bill of materials is provided in Table 1.

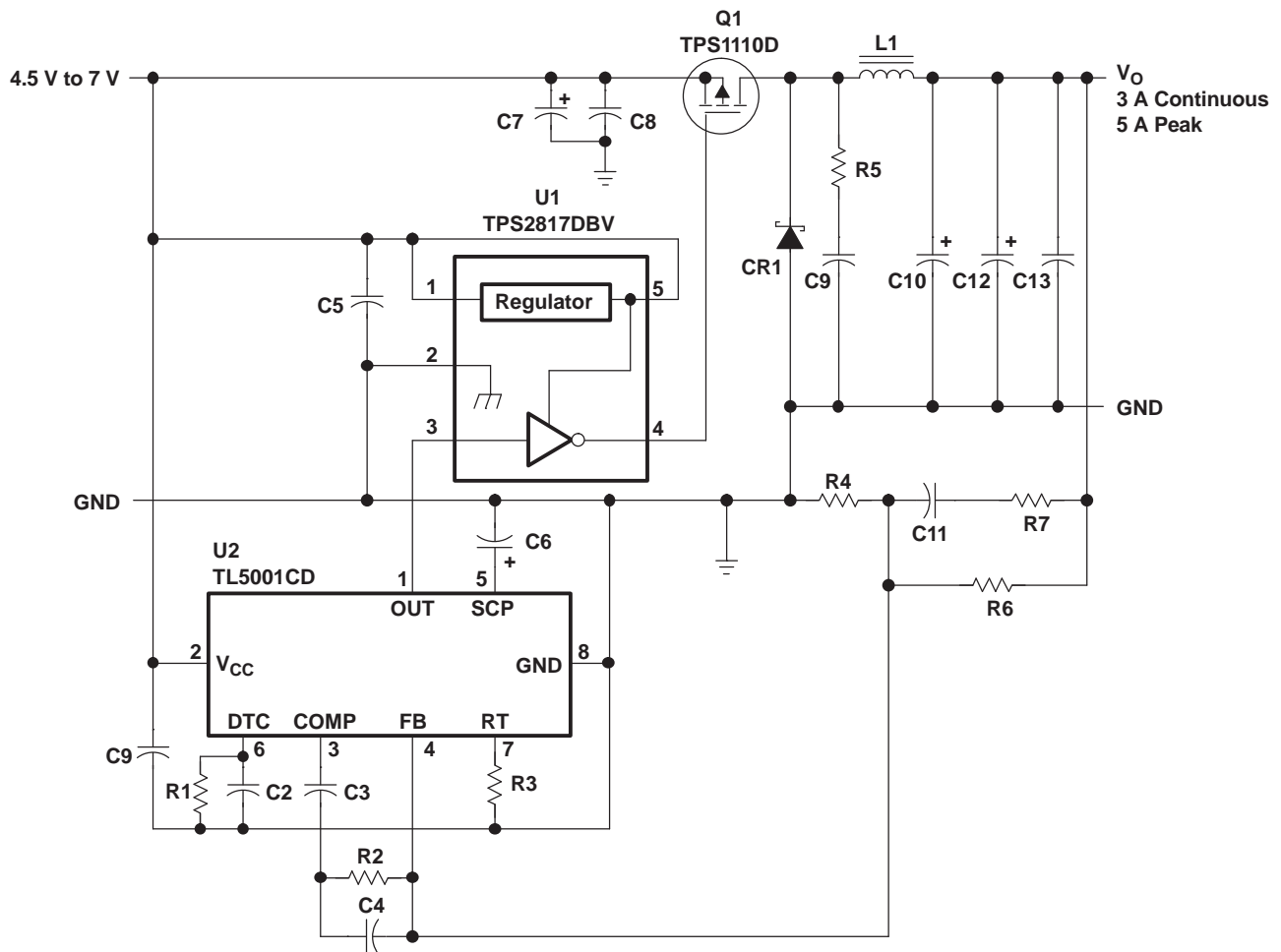

Figure 23. Step-Down Application

NOTE:

If the parasitics of the external circuit cause the voltage to violate the Absolute Maximum Rating for the Output pins, Schottky diodes should be added from ground to output and from output to V_{CC} .

Table 1. Bill of Materials

REF DES	PART NO.	DESCRIPTION	MFR
U1	TPS2817DBV	IC, MOSFET driver, single noninverting	TI
U2	TL5001CD	IC, PWM controller	TI
Q1	TPS1110D	MOSFET, p-channel, 6 A, 7 V, 75 mΩ	TI
C1, C2, C5, C8		Capacitor, ceramic, 0.1 μF, 50 V, X7R, 1206	
C3		Capacitor, ceramic, 0.033 μF, 50 V, X7R, 1206	
C4		Capacitor, ceramic, 2200 pF, 50 V, X7R, 0805	
C6	ECS-T1CY105R	Capacitor, tantalum, 1.0 μF, 16 V, A case	Panasonic
C7	10SC47M	Capacitor, OS-Con, 47 μF, 10 V	Sanyo
C9		Capacitor, ceramic, 1000 pF, 50 V, X7R, 0805	
C10, C12	10SA220M	Capacitor, OS-Con, 220 μF, 10 V	Sanyo
C11		Capacitor, ceramic, 0.022 μF, 50 V, X7R, 0805	
C13		Capacitor, ceramic, 47 μF, 50 V, X7R	
CR1	50WQ03F	Diode, Schottky, D-pak, 5 A 30 V	IR
L1	SML3723	Inductor, 27 μH, ±20%, 3 A	Nova Magnetics
R1		Resistor, CF, 47 kΩ, 1/10 W, 5%, 0805	
R2		Resistor, CF, 1.5 kΩ, 1/10 W, 5%, 0805	
R3		Resistor, MF, 30.1 kΩ, 1/10 W, 1%, 0805	
R4		Resistor, MF, 1.00 kΩ, 1/10 W, 1%, 0805	
R5		Resistor, CF, 47 Ω, 1/10 W, 5%, 0805	
R6 (3.3-V)		Resistor, MF, 2.32 kΩ, 1/10 W, 1%, 0805	
R6 (2.5-V)		Resistor, MF, 1.50 kΩ, 1/10 W, 1%, 0805	
R7		Resistor, CF, 100 Ω, 1/10 W, 5%, 0805	

As shown in [Figure 24](#) and [Figure 25](#), the TPS2817 turns on the TPS1110 power switch in less than 20 ns and off in 25 ns.

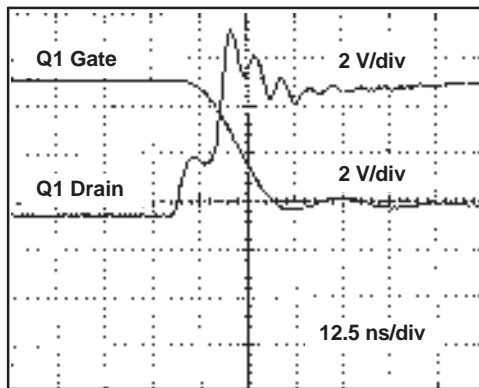

Figure 24. Q1 Turn-On Waveform

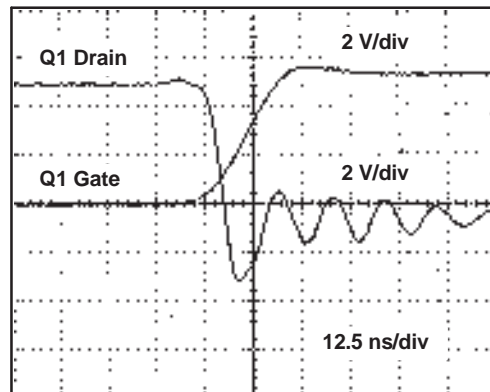

Figure 25. Q1 Turn-Off Waveform

The efficiency for various output currents, with a 5.25-V input, is shown in [Figure 26](#). For a 3.3-V output, the efficiency is greater than 90% for loads up to 2 A – exceptional for a simple, inexpensive design.

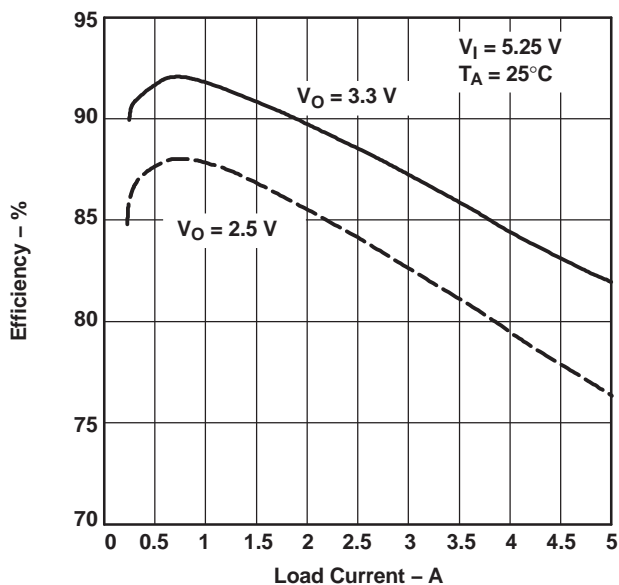

Figure 26. Converter Efficiency

PACKAGING INFORMATION

Orderable Device	Status (1)	Package Type	Package Drawing	Pins	Package Qty	Eco Plan (2)	Lead/Ball Finish (6)	MSL Peak Temp (3)	Op Temp (°C)	Device Marking (4/5)	Samples
TPS2818MDBVREP	ACTIVE	SOT-23	DBV	5	3000	Green (RoHS & no Sb/Br)	CU NIPDAU	Level-1-260C-UNLIM	-55 to 125	PMTM	Samples
TPS2818MDBVREPG4	ACTIVE	SOT-23	DBV	5	3000	Green (RoHS & no Sb/Br)	CU NIPDAU	Level-1-260C-UNLIM	-55 to 125	PMTM	Samples
TPS2819MDBVREP	ACTIVE	SOT-23	DBV	5	3000	Green (RoHS & no Sb/Br)	CU NIPDAU	Level-1-260C-UNLIM	-55 to 125	PMUM	Samples
V62/08601-03XE	ACTIVE	SOT-23	DBV	5	3000	Green (RoHS & no Sb/Br)	CU NIPDAU	Level-1-260C-UNLIM	-55 to 125	PMTM	Samples
V62/08601-04XE	ACTIVE	SOT-23	DBV	5	3000	Green (RoHS & no Sb/Br)	CU NIPDAU	Level-1-260C-UNLIM	-55 to 125	PMUM	Samples

(1) The marketing status values are defined as follows:

ACTIVE: Product device recommended for new designs.

LIFEBUY: TI has announced that the device will be discontinued, and a lifetime-buy period is in effect.

NRND: Not recommended for new designs. Device is in production to support existing customers, but TI does not recommend using this part in a new design.

PREVIEW: Device has been announced but is not in production. Samples may or may not be available.

OBSELETE: TI has discontinued the production of the device.

(2) **RoHS:** TI defines "RoHS" to mean semiconductor products that are compliant with the current EU RoHS requirements for all 10 RoHS substances, including the requirement that RoHS substance do not exceed 0.1% by weight in homogeneous materials. Where designed to be soldered at high temperatures, "RoHS" products are suitable for use in specified lead-free processes. TI may reference these types of products as "Pb-Free".

RoHS Exempt: TI defines "RoHS Exempt" to mean products that contain lead but are compliant with EU RoHS pursuant to a specific EU RoHS exemption.

Green: TI defines "Green" to mean the content of Chlorine (Cl) and Bromine (Br) based flame retardants meet JS709B low halogen requirements of <=1000ppm threshold. Antimony trioxide based flame retardants must also meet the <=1000ppm threshold requirement.

(3) MSL, Peak Temp. - The Moisture Sensitivity Level rating according to the JEDEC industry standard classifications, and peak solder temperature.

(4) There may be additional marking, which relates to the logo, the lot trace code information, or the environmental category on the device.

(5) Multiple Device Markings will be inside parentheses. Only one Device Marking contained in parentheses and separated by a "-" will appear on a device. If a line is indented then it is a continuation of the previous line and the two combined represent the entire Device Marking for that device.

(6) Lead/Ball Finish - Orderable Devices may have multiple material finish options. Finish options are separated by a vertical ruled line. Lead/Ball Finish values may wrap to two lines if the finish value exceeds the maximum column width.

Important Information and Disclaimer: The information provided on this page represents TI's knowledge and belief as of the date that it is provided. TI bases its knowledge and belief on information provided by third parties, and makes no representation or warranty as to the accuracy of such information. Efforts are underway to better integrate information from third parties. TI has taken and continues to take reasonable steps to provide representative and accurate information but may not have conducted destructive testing or chemical analysis on incoming materials and chemicals. TI and TI suppliers consider certain information to be proprietary, and thus CAS numbers and other limited information may not be available for release.

In no event shall TI's liability arising out of such information exceed the total purchase price of the TI part(s) at issue in this document sold by TI to Customer on an annual basis.

OTHER QUALIFIED VERSIONS OF TPS2818-EP, TPS2819-EP :

- Catalog: [TPS2818](#), [TPS2819](#)
- Automotive: [TPS2819-Q1](#)

NOTE: Qualified Version Definitions:

- Catalog - TI's standard catalog product
- Automotive - Q100 devices qualified for high-reliability automotive applications targeting zero defects

TAPE AND REEL INFORMATION

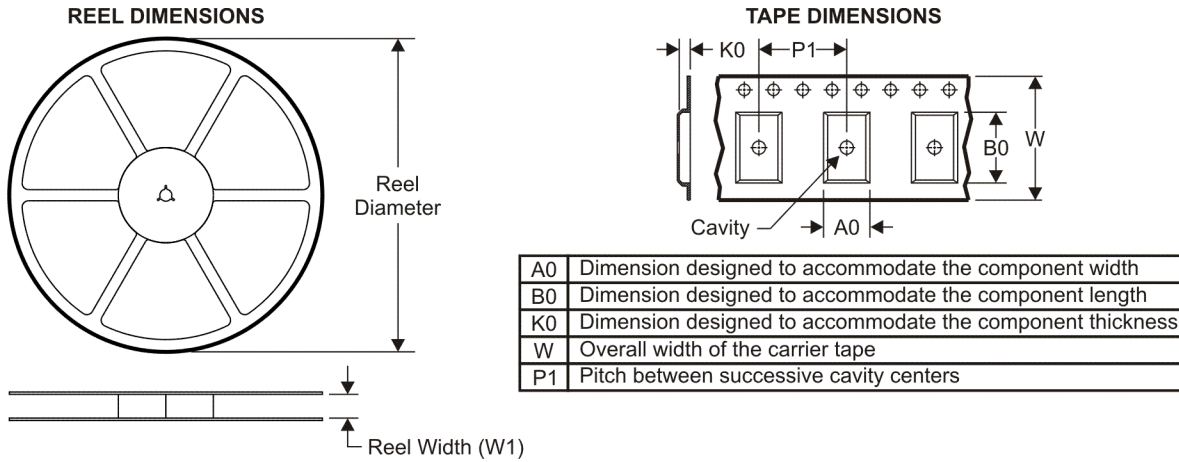

QUADRANT ASSIGNMENTS FOR PIN 1 ORIENTATION IN TAPE

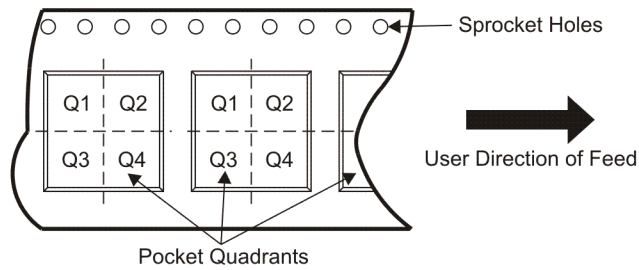

*All dimensions are nominal

Device	Package Type	Package Drawing	Pins	SPQ	Reel Diameter (mm)	Reel Width W1 (mm)	A0 (mm)	B0 (mm)	K0 (mm)	P1 (mm)	W (mm)	Pin1 Quadrant
TPS2818MDBVREP	SOT-23	DBV	5	3000	180.0	9.0	3.15	3.2	1.4	4.0	8.0	Q3
TPS2819MDBVREP	SOT-23	DBV	5	3000	180.0	9.0	3.15	3.2	1.4	4.0	8.0	Q3

TAPE AND REEL BOX DIMENSIONS

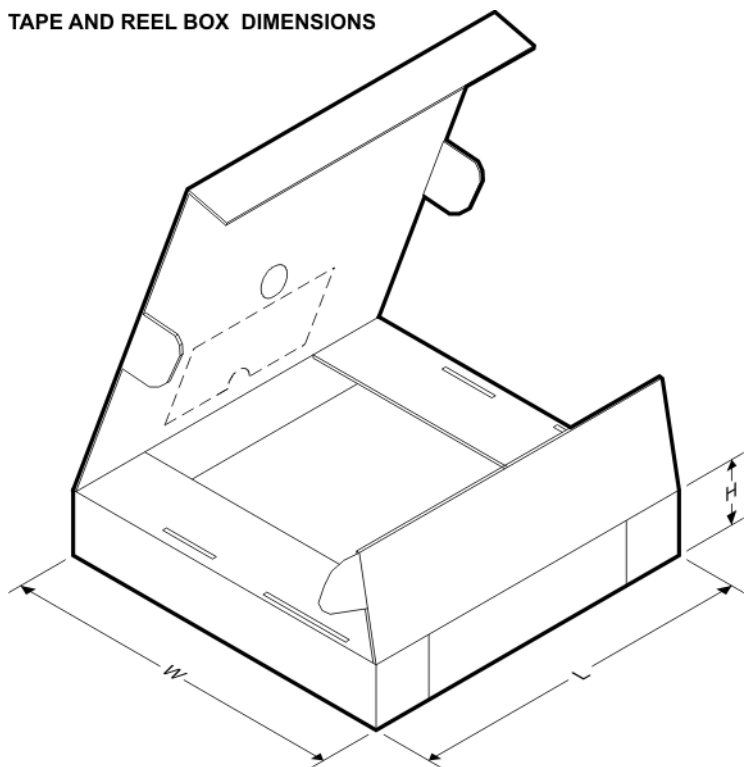

*All dimensions are nominal

Device	Package Type	Package Drawing	Pins	SPQ	Length (mm)	Width (mm)	Height (mm)
TPS2818MDBVREP	SOT-23	DBV	5	3000	182.0	182.0	20.0
TPS2819MDBVREP	SOT-23	DBV	5	3000	182.0	182.0	20.0

DBV0005A



PACKAGE OUTLINE

SOT-23 - 1.45 mm max height

SMALL OUTLINE TRANSISTOR



4214839/D 11/2018

NOTES:

1. All linear dimensions are in millimeters. Any dimensions in parenthesis are for reference only. Dimensioning and tolerancing per ASME Y14.5M.
2. This drawing is subject to change without notice.
3. Reference JEDEC MO-178.
4. Body dimensions do not include mold flash, protrusions, or gate burrs. Mold flash, protrusions, or gate burrs shall not exceed 0.15 mm per side.

EXAMPLE BOARD LAYOUT

DBV0005A

SOT-23 - 1.45 mm max height

SMALL OUTLINE TRANSISTOR



LAND PATTERN EXAMPLE
EXPOSED METAL SHOWN
SCALE:15X

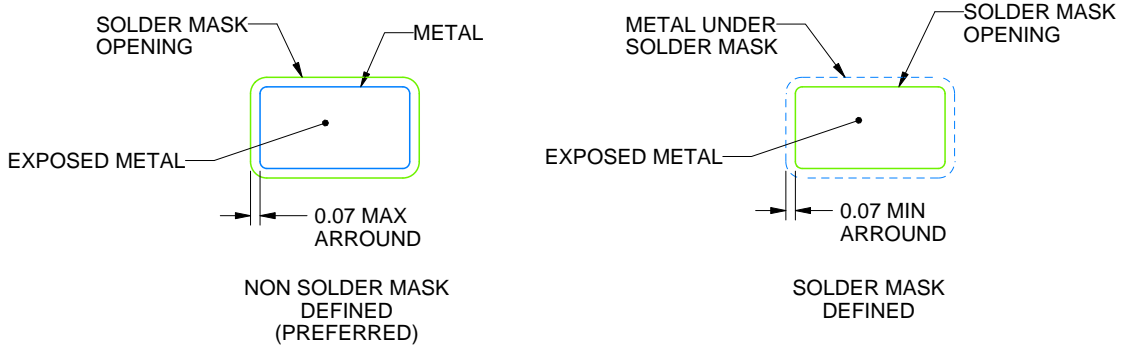

SOLDER MASK DETAILS

4214839/D 11/2018

NOTES: (continued)

- 5. Publication IPC-7351 may have alternate designs.
- 6. Solder mask tolerances between and around signal pads can vary based on board fabrication site.

EXAMPLE STENCIL DESIGN

DBV0005A

SOT-23 - 1.45 mm max height

SMALL OUTLINE TRANSISTOR



SOLDER PASTE EXAMPLE
BASED ON 0.125 mm THICK STENCIL
SCALE:15X

4214839/D 11/2018

NOTES: (continued)

7. Laser cutting apertures with trapezoidal walls and rounded corners may offer better paste release. IPC-7525 may have alternate design recommendations.
8. Board assembly site may have different recommendations for stencil design.

IMPORTANT NOTICE AND DISCLAIMER

TI PROVIDES TECHNICAL AND RELIABILITY DATA (INCLUDING DATASHEETS), DESIGN RESOURCES (INCLUDING REFERENCE DESIGNS), APPLICATION OR OTHER DESIGN ADVICE, WEB TOOLS, SAFETY INFORMATION, AND OTHER RESOURCES "AS IS" AND WITH ALL FAULTS, AND DISCLAIMS ALL WARRANTIES, EXPRESS AND IMPLIED, INCLUDING WITHOUT LIMITATION ANY IMPLIED WARRANTIES OF MERCHANTABILITY, FITNESS FOR A PARTICULAR PURPOSE OR NON-INFRINGEMENT OF THIRD PARTY INTELLECTUAL PROPERTY RIGHTS.

These resources are intended for skilled developers designing with TI products. You are solely responsible for (1) selecting the appropriate TI products for your application, (2) designing, validating and testing your application, and (3) ensuring your application meets applicable standards, and any other safety, security, or other requirements. These resources are subject to change without notice. TI grants you permission to use these resources only for development of an application that uses the TI products described in the resource. Other reproduction and display of these resources is prohibited. No license is granted to any other TI intellectual property right or to any third party intellectual property right. TI disclaims responsibility for, and you will fully indemnify TI and its representatives against, any claims, damages, costs, losses, and liabilities arising out of your use of these resources.

TI's products are provided subject to TI's Terms of Sale (www.ti.com/legal/termsofsale.html) or other applicable terms available either on ti.com or provided in conjunction with such TI products. TI's provision of these resources does not expand or otherwise alter TI's applicable warranties or warranty disclaimers for TI products.

Mailing Address: Texas Instruments, Post Office Box 655303, Dallas, Texas 75265
Copyright © 2019, Texas Instruments Incorporated

Looking for pricing, stock, or lifecycle information?

Click below to explore more details on WIN SOURCE:

 [View TPS2819MDBVREP](#) on WIN SOURCE

 [Texas Instruments](#) Information

Optimize Your Supply Chain with WIN SOURCE Solutions

-  Global Sourcing Solution
-  Obsolete Management
-  Cost Control Management
-  Shortage Management
-  Alternative Solution
-  Excess Inventory Management