



**THE DATASHEET OF
ST3485EBN**





ST3485E

3.3V Powered, 15KV ESD protected,
Up to 12Mbps RS-485/RS-422 transceiver

General features

- ESD protection
 - $\pm 15\text{kV}$ human body model
 - $\pm 8\text{kV}$ IEC 1000-4-2 contact discharge
- Operate from a single 3.3V supply - no charge pump required
- Interoperable with 5V logic
- $1\mu\text{A}$ low current shutdown mode max
- Guaranteed 12Mbps data rate
- -7 to 12 common mode input voltage range
- Half duplex versions available
- Industry standard 75176 pinout
- Current limiting and thermal shutdown for driver overload protection
- Guaranteed high receiver output state for floating inputs with no signal present
- Allow up to 64 transceivers on the bus

Description

The ST3485E is $\pm 15\text{kV}$ ESD protected, 3.3V low power transceiver for RS-485 and RS-422 communications. The device contains one driver

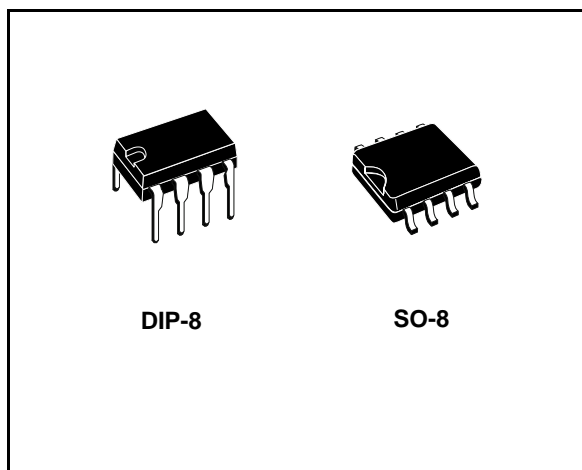

and one receiver in half duplex configuration. The ST3485E transmits and receives at a guaranteed data rate of at least 12Mbps.

All transmitter outputs and receiver inputs are protected to $\pm 15\text{kV}$ using Human Body Model.

Driver is short-circuit current limited and is protected against excessive power dissipation by thermal shutdown circuitry that places the driver outputs into a high-impedance state.

Order code

Part number	Temperature range	Package	Comments
ST3485ECN	0 to 70 °C	DIP-8	50parts per tube / 40tube per box
ST3485EBN	-40 to 85 °C	DIP-8	50parts per tube / 40tube per box
ST3485ECDR	0 to 70 °C	SO-8 (Tape & Reel)	2500 parts per reel
ST3485EBDR	-40 to 85 °C	SO-8 (Tape & Reel)	2500 parts per reel

Contents

1	Pin configuration	3
2	Truth tables	4
3	Maximum ratings	5
4	Electrical characteristics	6
5	Test circuits and typical characteristics	9
6	Package mechanical data	17
7	Revision history	21

1 Pin configuration

Figure 1. Pin connections

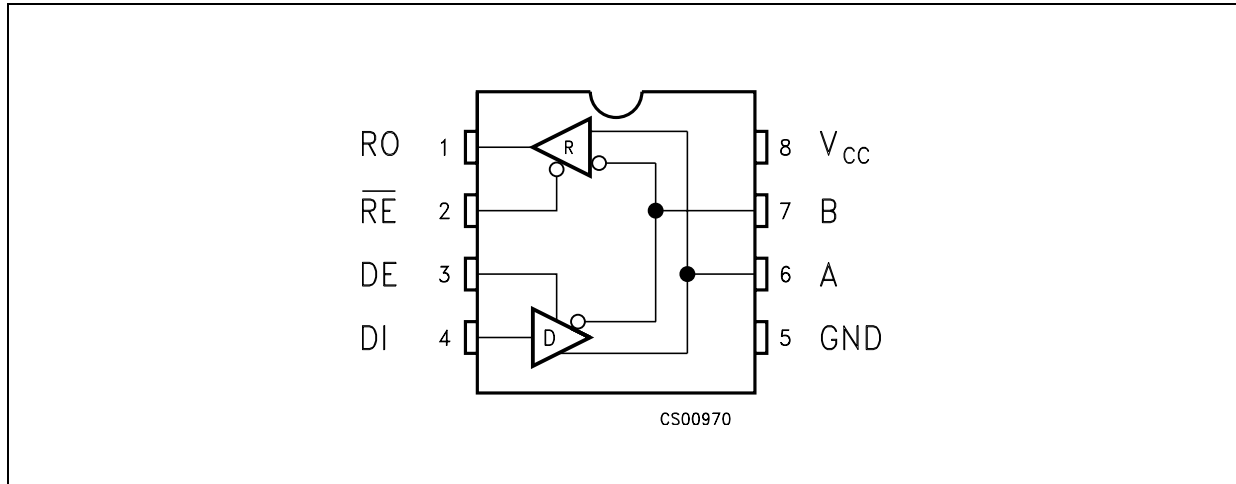

Table 1. Pin description

Pin n°	Symbol	Name and function
1	RO	Receiver output. If $A > B$ by 200mV, RO will be high; if $A < B$ by 200mV, RO will be low
2	\overline{RE}	Receiver output enable. RO is enabled when RE is low; RO is high impedance when RE is high. If RE is high and DE is low, the device will enter a low power shutdown mode.
3	DE	Driver output enable. The driver outputs are enabled by bringing DE high. They are high impedance when DE is low. If RE is high DE is low, the device will enter a low-power shutdown mode. If the driver outputs are enabled, the part functions as line driver, while they are high impedance, it functions as line receivers if RE is low.
4	DI	Driver input. A low on DI forces output A low and output B high. Similarly, a high on DI forces output A high and output B low
5	GND	Ground
6	A	Non-inverting receiver input and non-inverting driver output
7	B	Inverting receiver input and inverting driver output
8	V_{CC}	Supply voltage: $V_{CC} = 3V$ to $3.6V$

2 Truth tables

Table 2. Truth table (driver)

Inputs			Outputs		Mode
RE	DE	DI	B	A	
X	H	H	L	H	Normal
X	H	L	H	L	Normal
L	L	X	Z	Z	Normal
H	L	X	Z	Z	Shutdown

Note: X= Don't care; Z=High impedance

Table 3. Truth table (receiver)

INPUTS			OUTPUT	MODE
RE	DE	A-B	RO	
L	L	$\geq 0.2V$	H	Normal
L	L	$\leq -0.2V$	L	Normal
L	L	Inputs Open	H	Normal
H	L	X	Z	Shutdown

Note: X= Don't care; Z=High impedance

3 Maximum ratings

Table 4. Absolute maximum ratings

Symbol	Parameter	Value	Unit
V_{CC}	Supply voltage	7	V
V_I	Control input voltage (\overline{RE} , DE)	-0.3 to 7	V
V_{DI}	Driver input voltage (DI)	-0.3 to 7	V
V_{DO}	Driver output voltage (A, B)	± 14	V
V_{RI}	Receiver input voltage (A, B)	± 14	V
V_{RO}	Receiver output voltage (RO)	-0.3 to ($V_{CC} + 0.3$)	V

Note: Absolute Maximum Ratings are those values beyond which damage to the device may occur. Functional operation under these condition is not implied.

Table 5. ESD Performance: transmitter outputs, receiver inputs

Symbol	Parameter	Test conditions	Min.	Typ.	Max.	Unit
ESD	ESD Protection voltage	Human body model		± 15		KV
ESD	ESD Protection voltage	IEC-1000-4-2 Contact discharge		± 8		KV

4 Electrical characteristics

Table 6. Electrical characteristics

$V_{CC} = 3V$ to $3.6V$, $T_A = -40$ to $85^\circ C$, unless otherwise specified. Typical values are referred to $T_A = 25^\circ C$)

Symbol	Parameter	Test conditions	Min.	Typ.	Max.	Unit	
I_{SUPPLY}	V_{CC} Power supply current	No Load, DI=0V or V_{CC}	$\overline{DE}=V_{CC}$, $\overline{RE}=0V$ or V_{CC}		1.3	2.2	mA
			$\overline{DE}=0V$, $\overline{RE}=0V$		1.2	1.9	mA
I_{SHDN}	Shutdown supply current	$\overline{DE}=0V$, $\overline{RE}=V_{CC}$, DI=0V or V_{CC}		0.002	1	μA	

Table 7. Logic input electrical characteristics

$V_{CC} = 3V$ to $3.6V$, $T_A = -40$ to $85^\circ C$, unless otherwise specified. Typical values are referred to $T_A = 25^\circ C$)

Symbol	Parameter	Test Conditions	Min.	Typ.	Max.	Unit
V_{IL}	Input logic threshold low	DE, DI, RE		1.3	0.8	V
V_{IH}	Input logic threshold high	DE, DI, RE	2			V
I_{IN1}	Logic input current	DE, DI, RE			± 2.0	μA
I_{IN2}	Input current (A, B)	$\overline{DE}=0V$, $V_{CC}= 0$ or $3.6V$	$V_{IN}=12V$		1	mA
			$V_{IN}=-7V$		-0.8	mA

Table 8. Transmitter electrical characteristics

$V_{CC} = 3V$ to $3.6V$, $T_A = -40$ to $85^\circ C$, unless otherwise specified. Typical values are referred to $T_a = 25^\circ C$)

Symbol	Parameter	Test conditions	Min.	Typ.	Max.	Unit
V_{OD}	Differential drive output	$R_L = 100\Omega$ (RS-422) (Figure 1.)	2			V
		$R_L = 54\Omega$ (RS-485) (Figure 1.)	1.5			V
		$R_L = 60\Omega$ (RS-485) (Figure 2.)	1.5			V
ΔV_{OD}	Change in magnitude of driver differential output voltage for complementary output states (Note: 1)	$R_L = 54\Omega$ or 100Ω (Figure 1.)			0.2	V
V_{OC}	Driver common mode output voltage	$R_L = 54\Omega$ or 100Ω (Figure 1.)			3	V
ΔV_{OC}	Change in magnitude of driver common mode output voltage (Note: 1)	$R_L = 54\Omega$ or 100Ω (Figure 1.)			0.2	V
I_{OSD}	Driver short circuit output current				± 250	mA

Table 9. Receiver electrical characteristics

$V_{CC} = 3V$ to $3.6V$, $T_A = -40$ to $85^\circ C$, unless otherwise specified. Typical values are referred to $T_a = 25^\circ C$)

Symbol	Parameter	Test Conditions	Min.	Typ.	Max.	Unit
V_{TH}	Receiver differential threshold voltage	$V_{CM} = -7V$ to $12V$, $DE = 0$	-0.2		0.2	V
ΔV_{TH}	Receiver input hysteresis	$V_{CM} = 0V$		70		V
V_{OH}	Receiver output high voltage	$I_{OUT} = -4mA$, $V_{ID} = 200mV$ (Figure 8. and Figure 9.)	2			V
V_{OL}	Receiver output low voltage	$I_{OUT} = 4mA$, $V_{ID} = -200mV$, (Figure 3.)			0.4	V
I_{OZR}	3-State (high impedance) output current at receiver	$V_{CC} = 3.6V$, $V_O = 0V$ to V_{CC}			± 1	μA
R_{RIN}	Receiver input resistance	$V_{CM} = -7V$ to $12V$	24			$K\Omega$
I_{OSR}	Receiver short-circuit current	$V_{RO} = 0V$ to V_{CC}	7		60	mA

Table 10. Driver switching characteristics

$V_{CC} = 3V$ to $3.6V$, $T_A = -40$ to $85^\circ C$, unless otherwise specified. Typical values are referred to $T_a = 25^\circ C$)

Symbol	Parameter	Test Conditions	Min.	Typ.	Max.	Unit
D_R	Maximum data rate		12	15		Mbps
t_{DD}	Differential output delay	$R_L = 60\Omega$, $C_L = 15pF$, (Figure 4. and Figure 5.)		18	30	ns
t_{TD}	Differential output transition time	$R_L = 60\Omega$, $C_L = 15pF$, (Figure 4. and Figure 5.)		12	20	ns
t_{PLH} t_{PHL}	Propagation delay	$R_L = 27\Omega$, $C_L = 15pF$, (Figure 8. and Figure 9.)		18	30	ns
t_{PDS}	$ t_{PLH} - t_{PHL} $ Propagation delay skew (Note 2)	$R_L = 27\Omega$, $C_L = 15pF$, (Figure 8. and Figure 9.)		2	5	ns
t_{PZL}	Output enable time	$R_L = 110\Omega$, (Figure 10. and Figure 11.)		19	35	ns
t_{PZH}	Output enable time	$R_L = 110\Omega$, (Figure 6. and Figure 7.)		30	50	ns
t_{PHZ}	Output disable time	$R_L = 110\Omega$, (Figure 6. and Figure 7.)		19	35	ns
t_{PLZ}	Output disable time	$R_L = 110\Omega$, (Figure 10. and Figure 11.)		30	50	ns
t_{SKEW}	Differential output delay skew			1	3	ns
$t_{ZH(SHDN)}$	Driver enable from shutdown to output high			30	50	ns
$t_{ZL(SHDN)}$	Driver enable from shutdown to output low			19	35	ns

Table 11. Receiver switching characteristics

$V_{CC} = 3V$ to $3.6V$, $T_A = -40$ to $85^\circ C$, unless otherwise specified. Typical values are referred to $T_a = 25^\circ C$)

Symbol	Parameter	Test Conditions	Min.	Typ.	Max.	Unit
t_{PLH} t_{PHL}	Propagation delay	$V_{ID} = 0V$ to $3V$, $C_{L1} = 15pF$ (<i>Figure 12.</i> and <i>Figure 13.</i>)		30	50	ns
t_{RPDS}	$ t_{PLH} - t_{PHL} $ Propagation delay skew	$V_{ID} = 0V$ to $3V$, $C_{L1} = 15pF$ (<i>Figure 12.</i> and <i>Figure 13.</i>)		1	3	ns
t_{PZL}	Output enable time	$C_{RL} = 15pF$, (<i>Figure 14.</i> and <i>Figure 18.</i>)		10	20	ns
t_{PZH}	Output enable time	$C_{RL} = 15pF$, (<i>Figure 14.</i> and <i>Figure 18.</i>)		10	20	ns
t_{PHZ}	Output disable time	$C_{RL} = 15pF$, (<i>Figure 14.</i> and <i>Figure 18.</i>)		10	20	ns
t_{PLZ}	Output disable time	$C_{RL} = 15pF$, (<i>Figure 14.</i> and <i>Figure 18.</i>)		10	20	ns
$t_{ZH(SHDN)}$	Receiver enable from shutdown to output high	$C_{RL} = 15pF$, (<i>Figure 14.</i> and <i>Figure 18.</i>)		10	20	ns
$t_{ZL(SHDN)}$	Receiver enable from shutdown to output low	$C_{RL} = 15pF$, (<i>Figure 14.</i> and <i>Figure 18.</i>)		20	40	μs

- Note: 1 ΔV_{OD} and ΔV_{OC} are the changes in V_{OD} and V_{OC} , respectively, when the DI input changes state.
- 2 Measured on $|t_{PLH(A)} - t_{PHL(A)}|$ and $|t_{PLH(B)} - t_{PHL(B)}|$
- 3 The transceivers are put into shutdown by bring RE high and DE low. If the input are in state for less than 80ns, the part are guaranteed not to enter shutdown. If the inputs are in this state for at least 300ns, the parts are guaranteed to have entered shutdown.

5 Test circuits and typical characteristics

Figure 2. Driver and V_{OC} test load

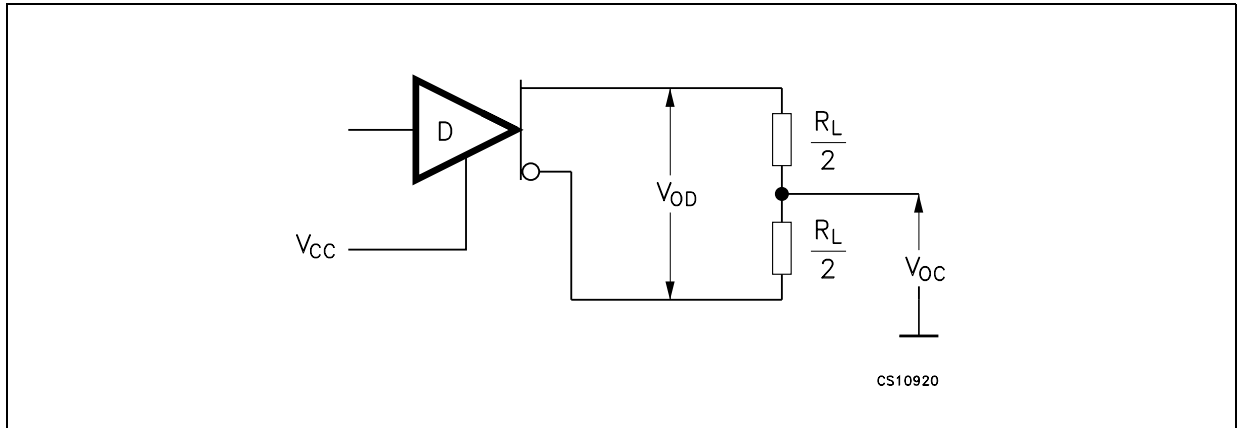

Figure 3. Driver V_{OD} with varying common mode voltage test load

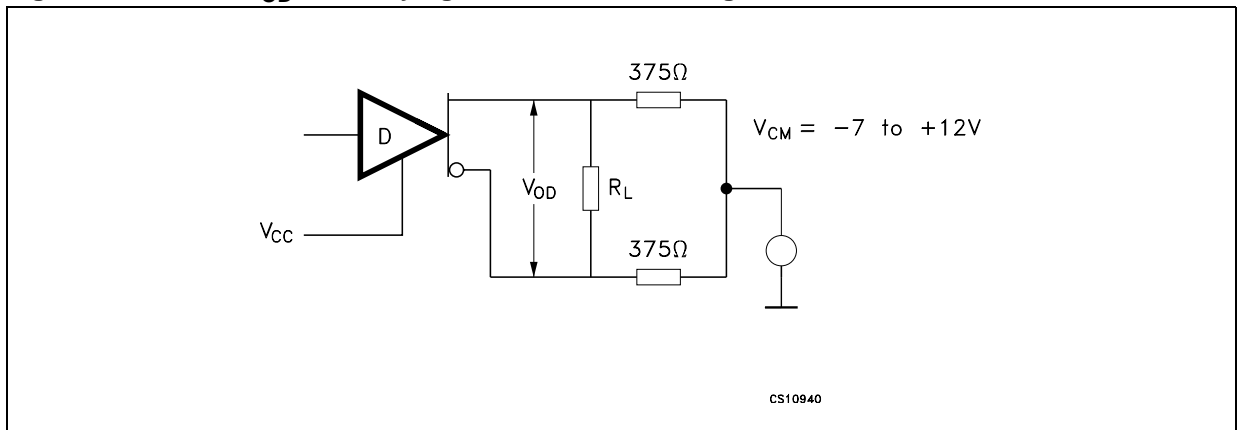

Figure 4. Receiver V_{OH} and V_{OL} test circuit

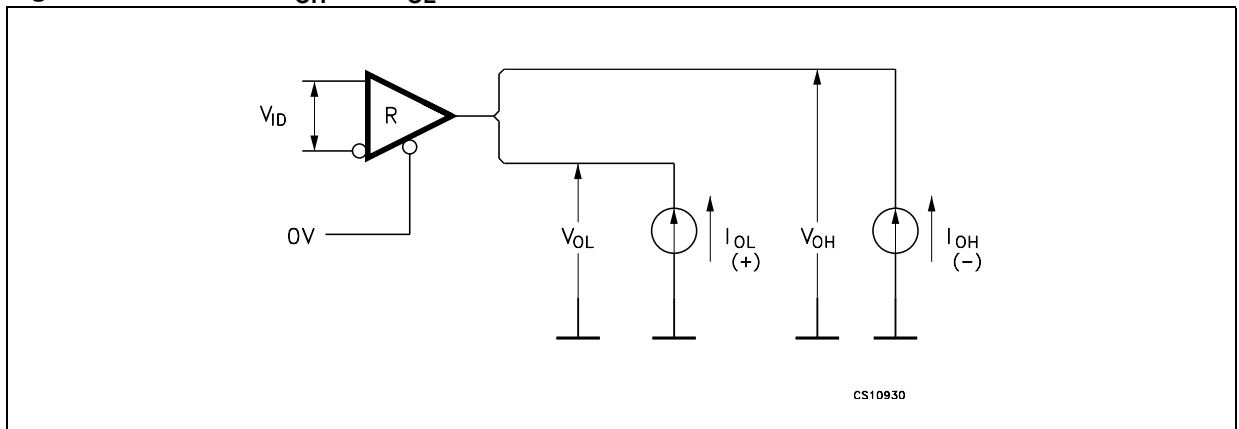

Figure 5. Drive differential output delay transition time test circuit

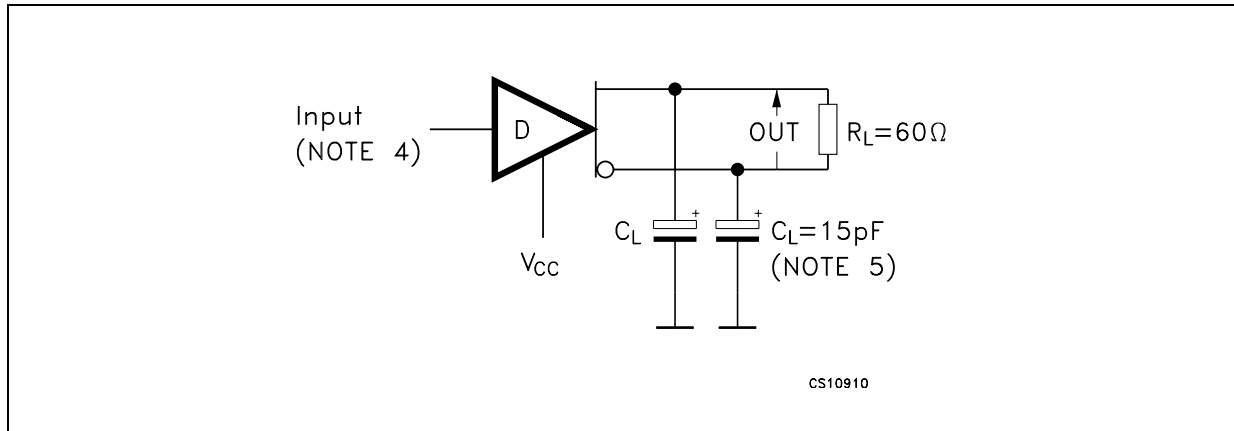

Figure 6. Drive differential output delay transition time waveform

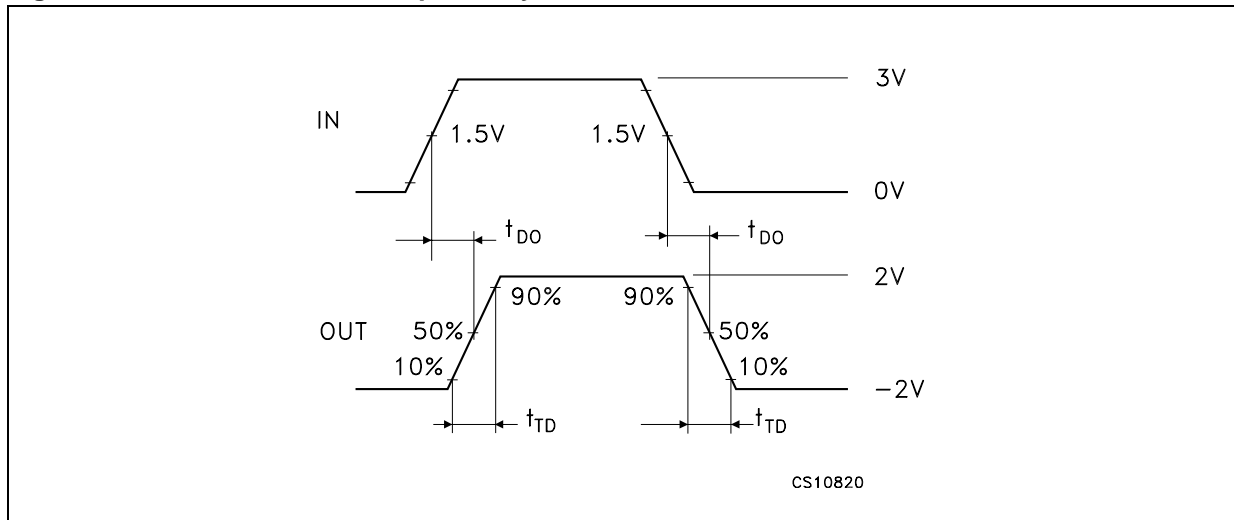

Figure 7. Drive enable and disable times test circuit

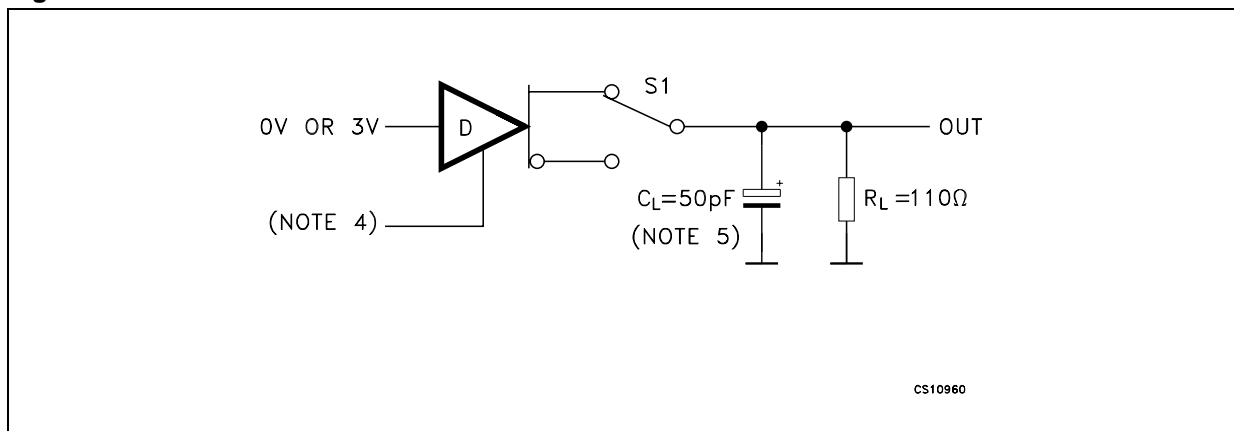

Figure 8. Drive enable and disable times waveforms

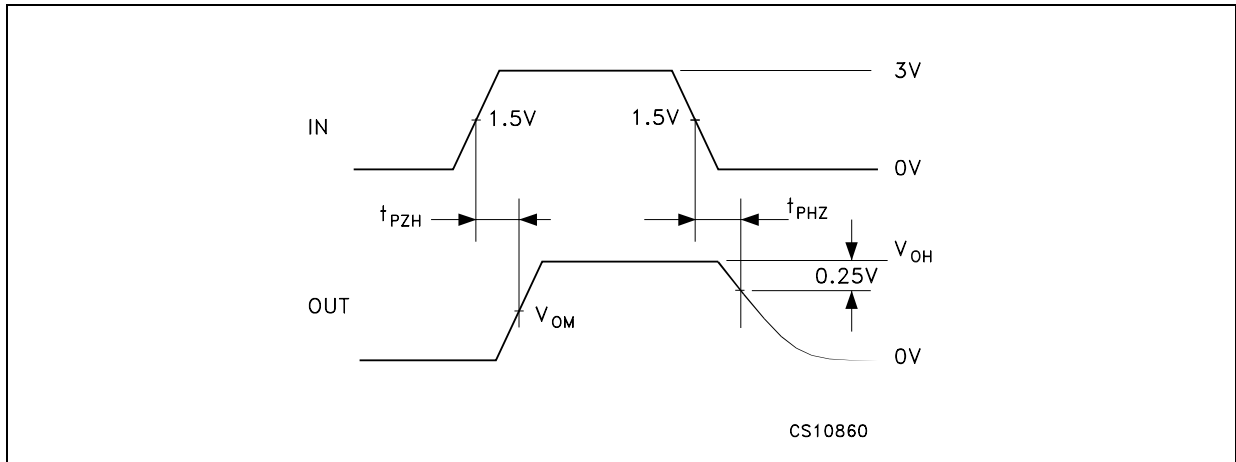

Figure 9. Drive propagation time test circuit

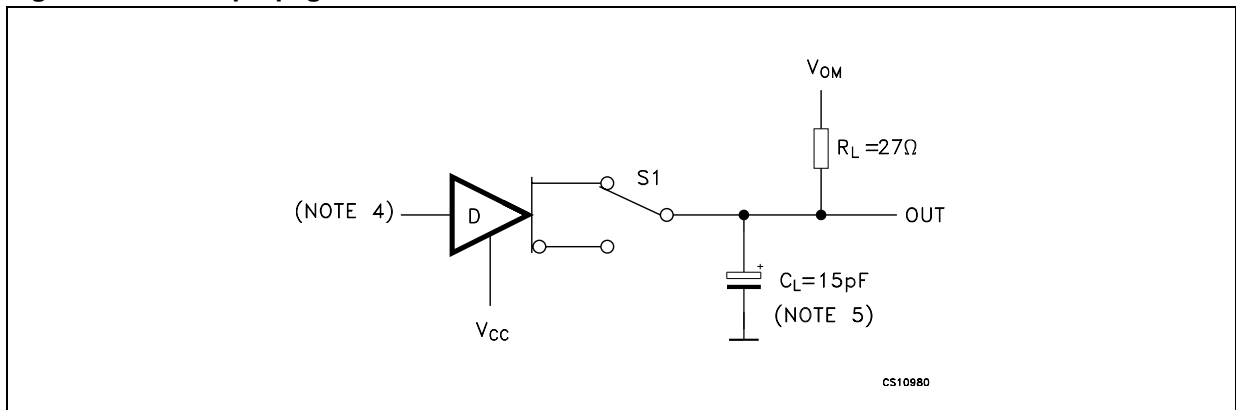

Figure 10. Drive propagation time waveform

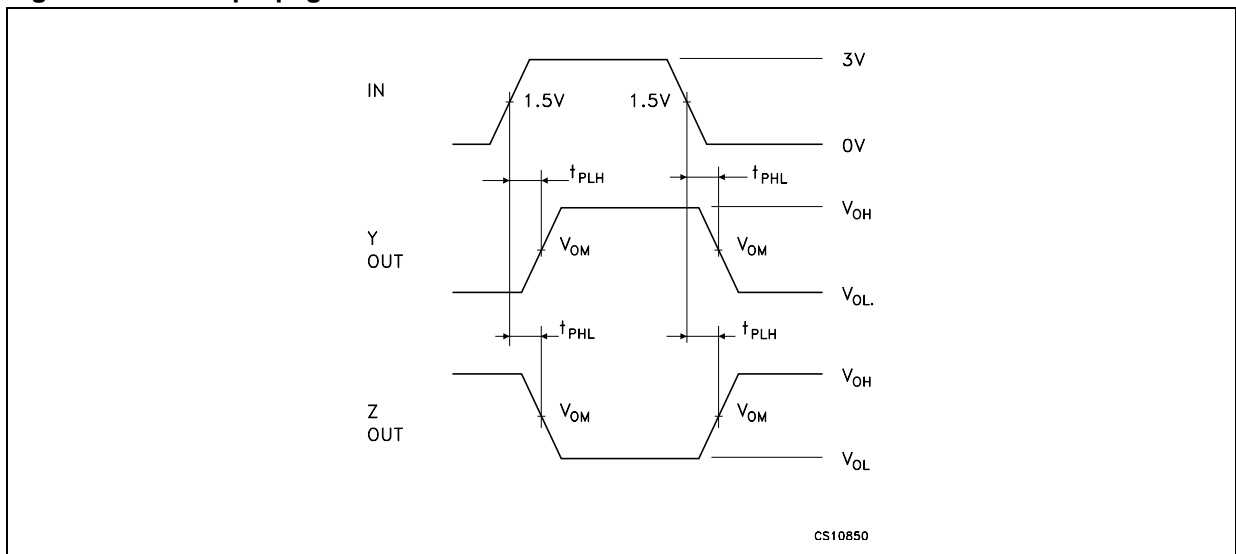

Figure 11. Drive enable and disable times test circuit

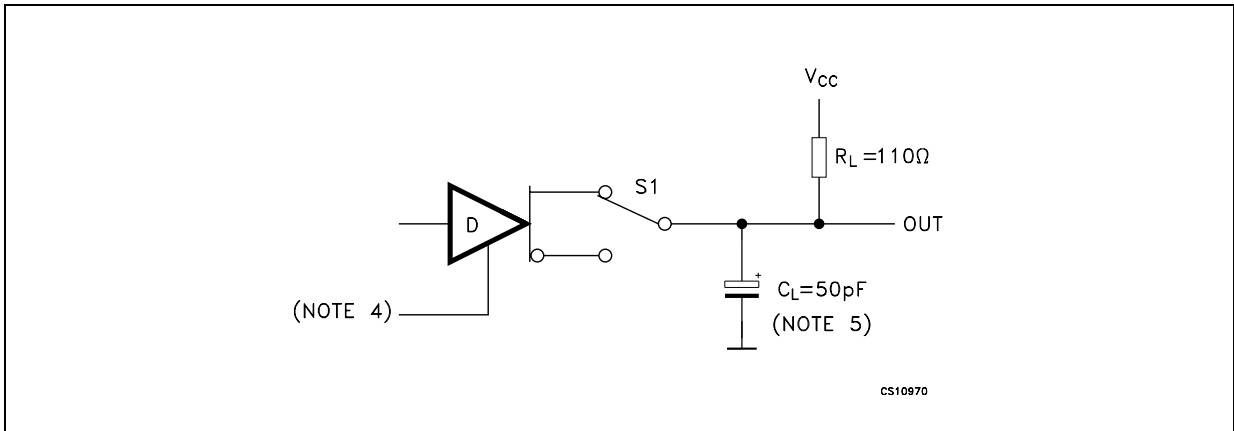

Figure 12. Drive enable and disable times waveforms

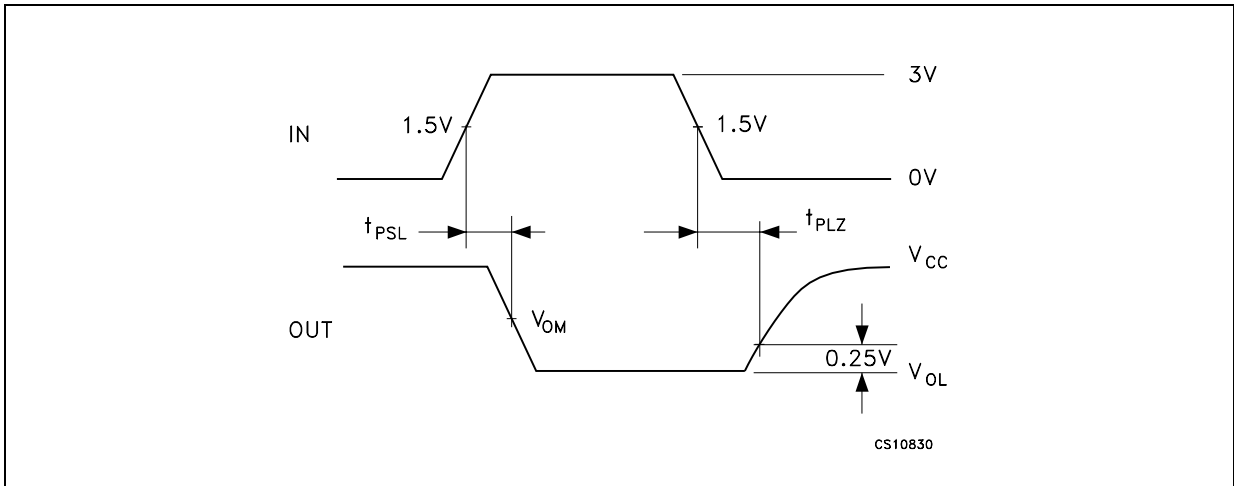

Figure 13. Receiver propagation delay time test circuit

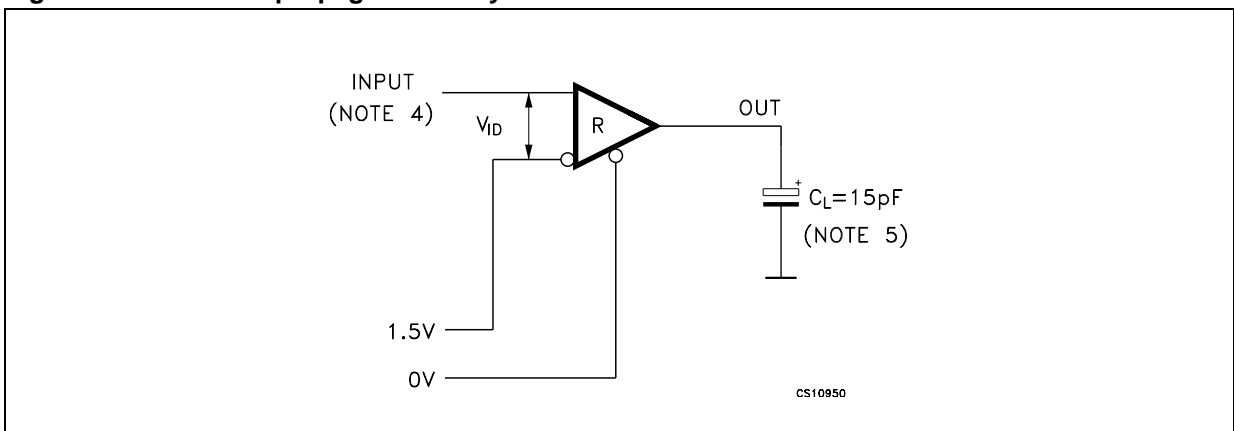

Figure 14. Receiver propagation delay time waveforms

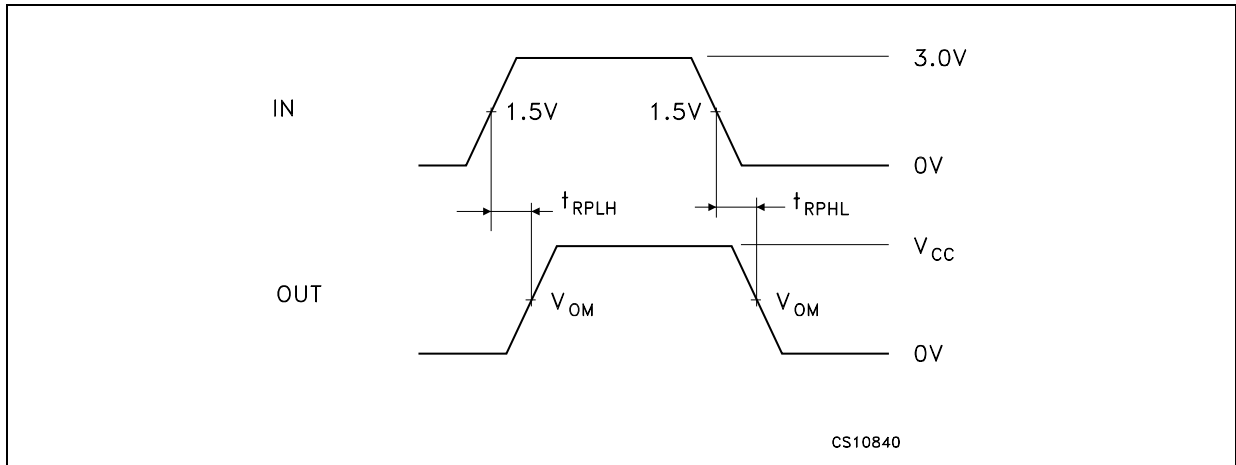

Figure 15. Receiver enable and disable times test circuit

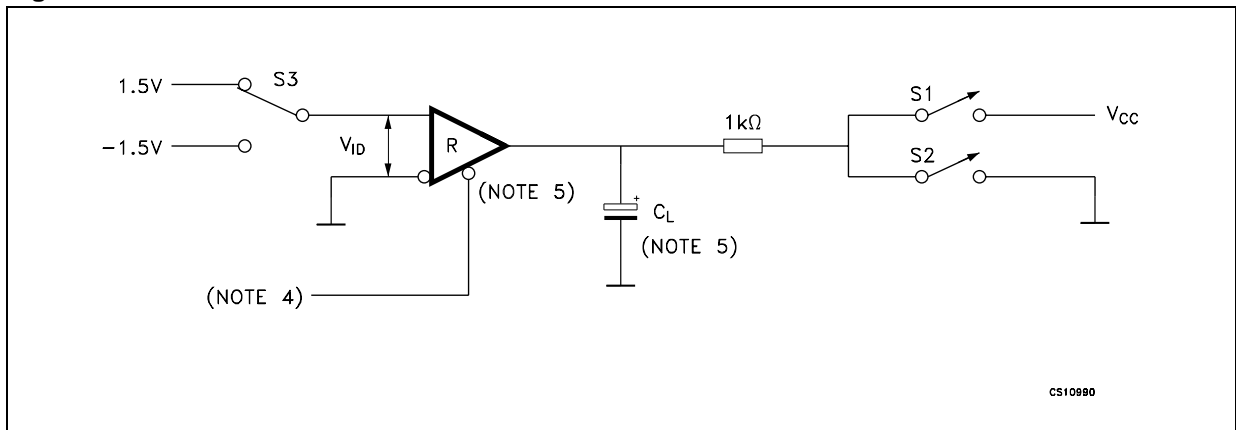

Figure 16. Receiver enable and disable times waveform

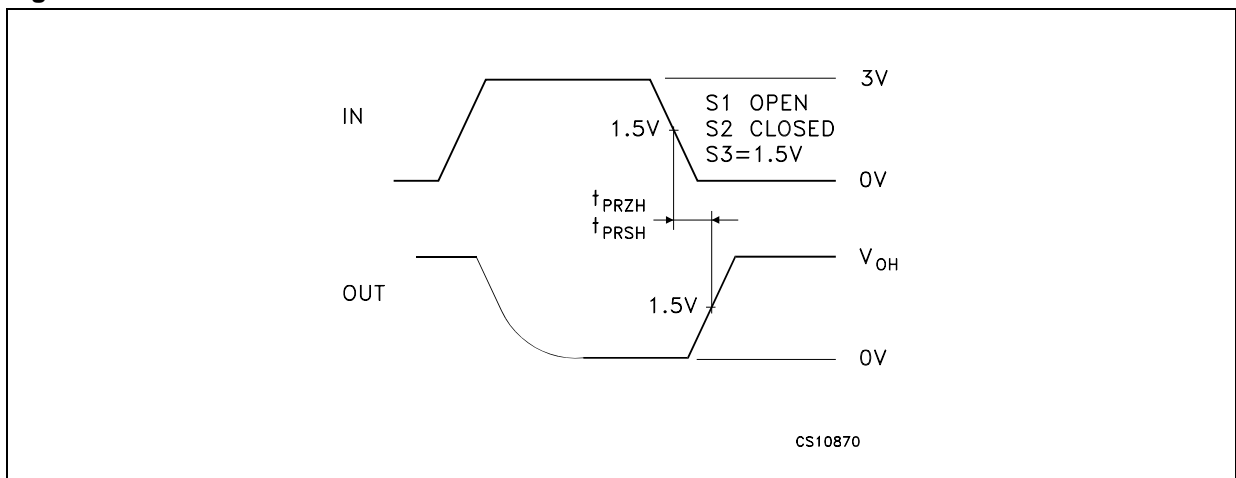

Figure 17. Receiver enable and disable times waveform

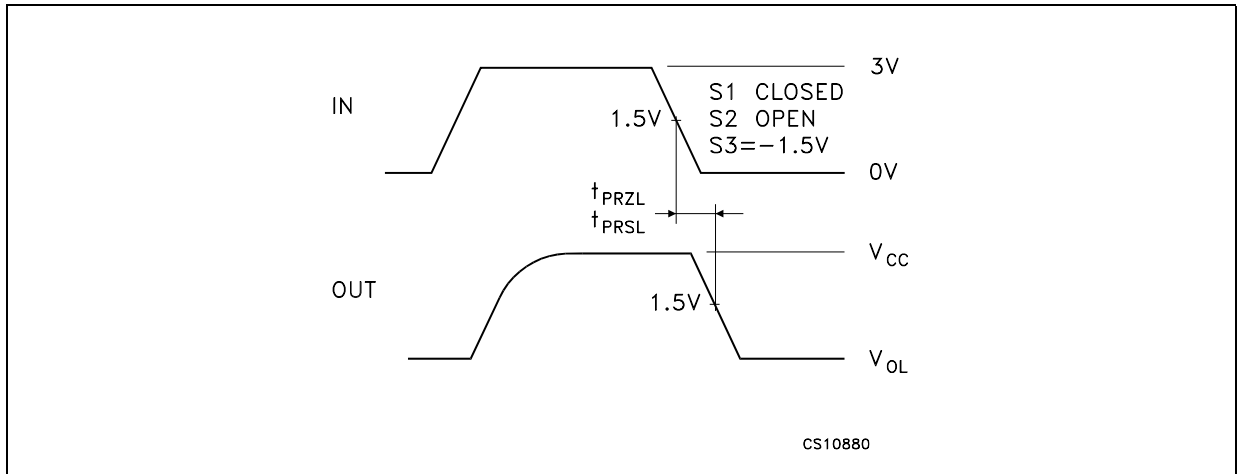

Figure 18. Receiver enable and disable times waveform

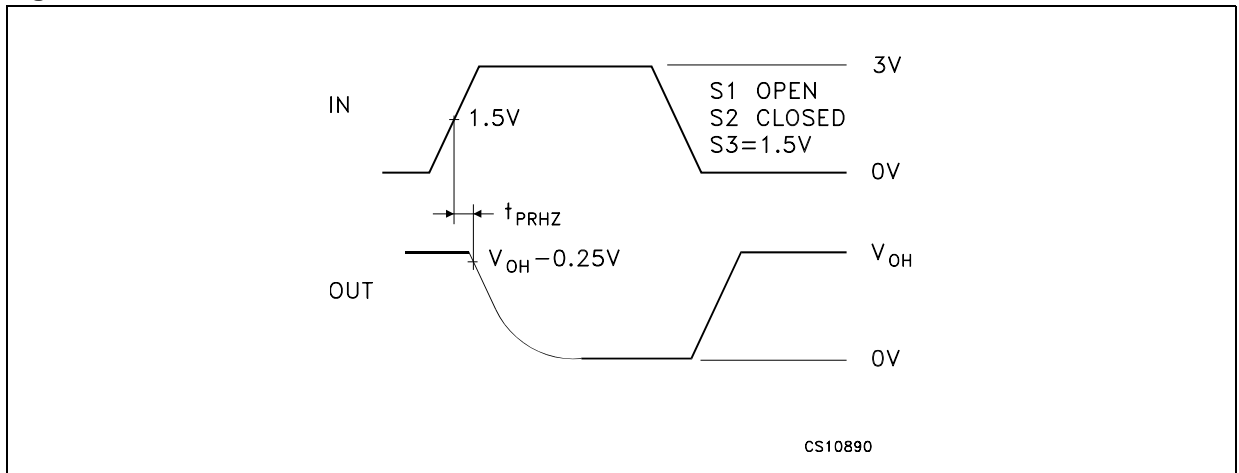

Figure 19. Receiver enable and disable times waveform

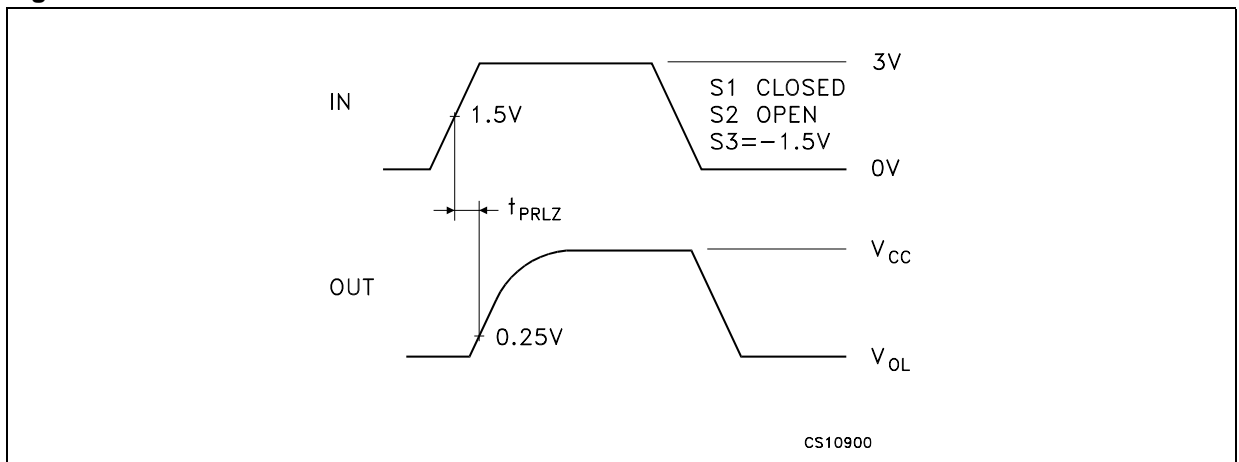

Figure 20. Receiver output current vs output low voltage

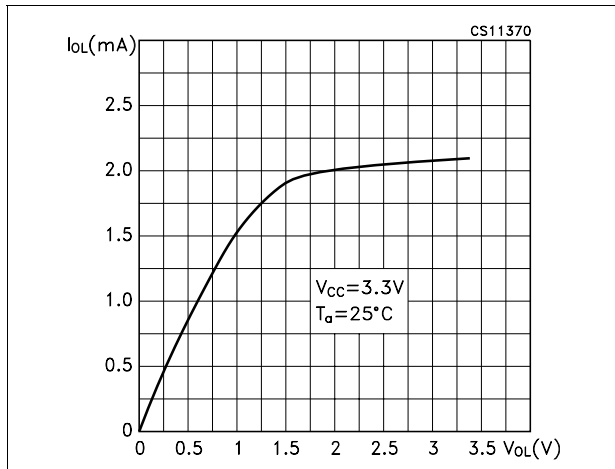

Figure 21. Receiver output current vs output high voltage

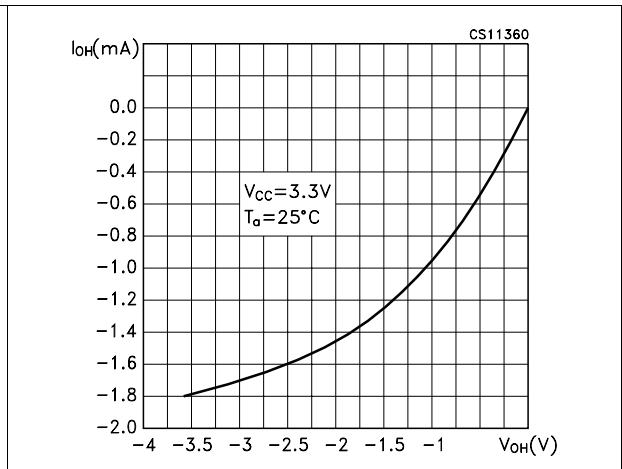

Figure 22. Low level driver output capability

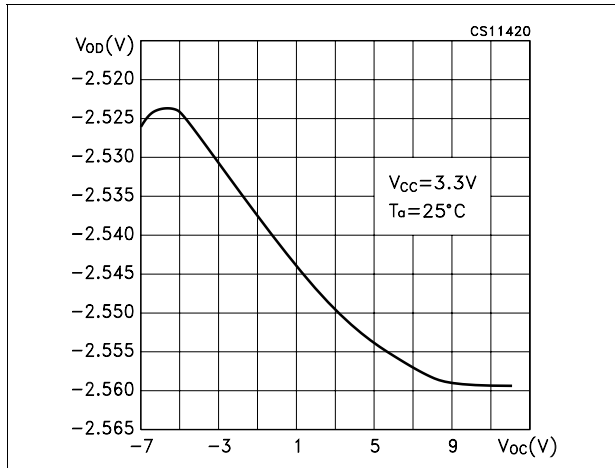

Figure 23. High level driver output capability

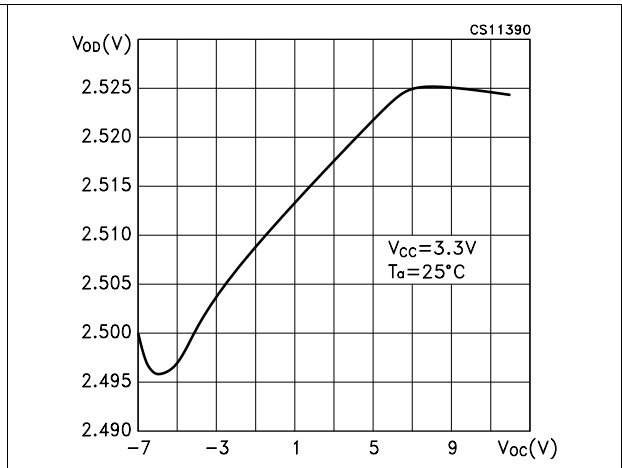

Figure 24. Receiver input characteristics

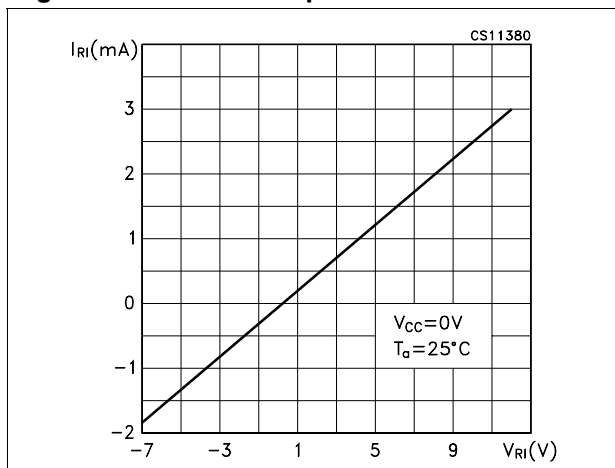

Figure 25. Driver short circuit current

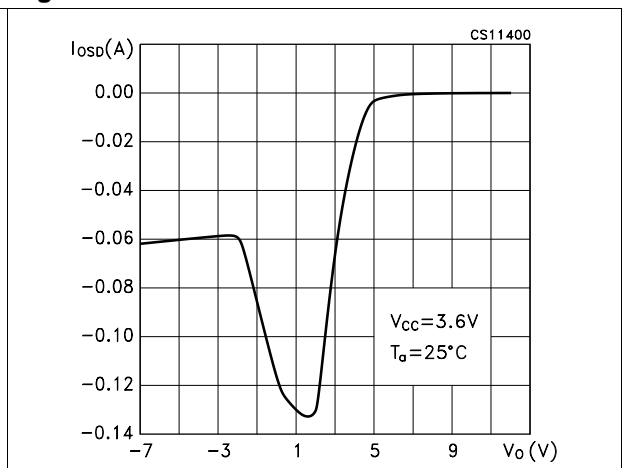
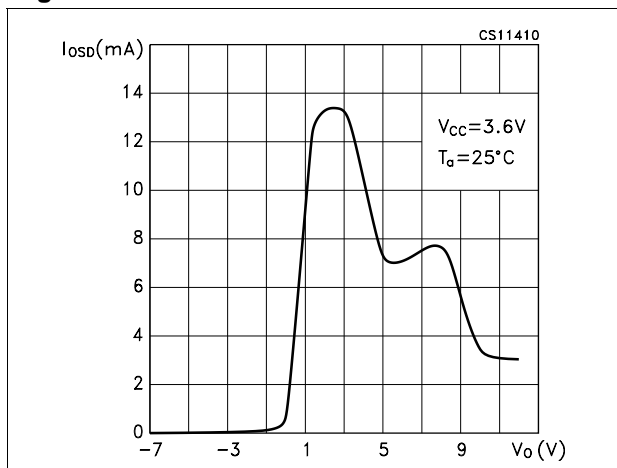

Figure 26. Driver short circuit current



6 Package mechanical data

In order to meet environmental requirements, ST offers these devices in ECOPACK® packages. These packages have a Lead-free second level interconnect. The category of second level interconnect is marked on the package and on the inner box label, in compliance with JEDEC Standard JESD97. The maximum ratings related to soldering conditions are also marked on the inner box label. ECOPACK is an ST trademark. ECOPACK specifications are available at: www.st.com

Plastic DIP-8 MECHANICAL DATA

DIM.	mm.			inch		
	MIN.	TYP	MAX.	MIN.	TYP.	MAX.
A		3.3			0.130	
a1	0.7			0.028		
B	1.39		1.65	0.055		0.065
B1	0.91		1.04	0.036		0.041
b		0.5			0.020	
b1	0.38		0.5	0.015		0.020
D			9.8			0.386
E		8.8			0.346	
e		2.54			0.100	
e3		7.62			0.300	
e4		7.62			0.300	
F			7.1			0.280
l			4.8			0.189
L		3.3			0.130	
Z	0.44		1.6	0.017		0.063

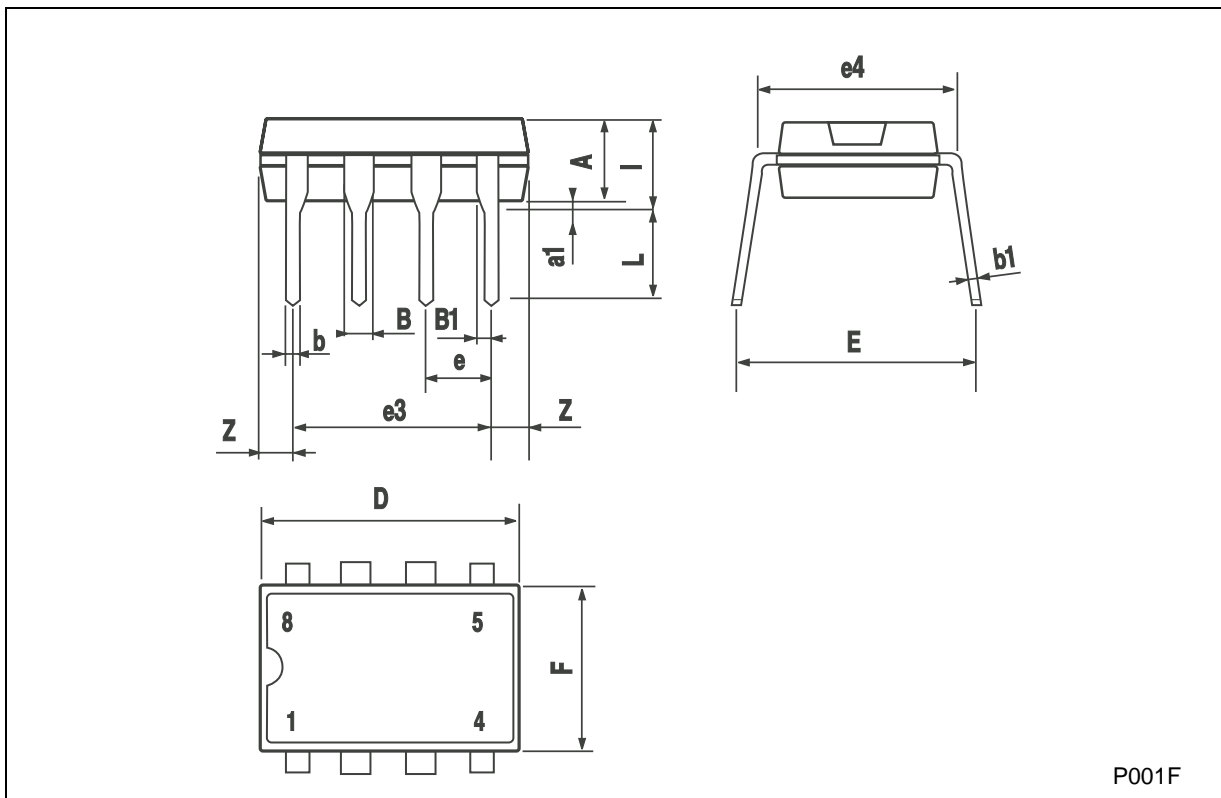

P001F

SO-8 MECHANICAL DATA

DIM.	mm.			inch		
	MIN.	TYP	MAX.	MIN.	TYP.	MAX.
A	1.35		1.75	0.053		0.069
A1	0.10		0.25	0.04		0.010
A2	1.10		1.65	0.043		0.065
B	0.33		0.51	0.013		0.020
C	0.19		0.25	0.007		0.010
D	4.80		5.00	0.189		0.197
E	3.80		4.00	0.150		0.157
e		1.27			0.050	
H	5.80		6.20	0.228		0.244
h	0.25		0.50	0.010		0.020
L	0.40		1.27	0.016		0.050
k	8° (max.)					
ddd			0.1			0.04

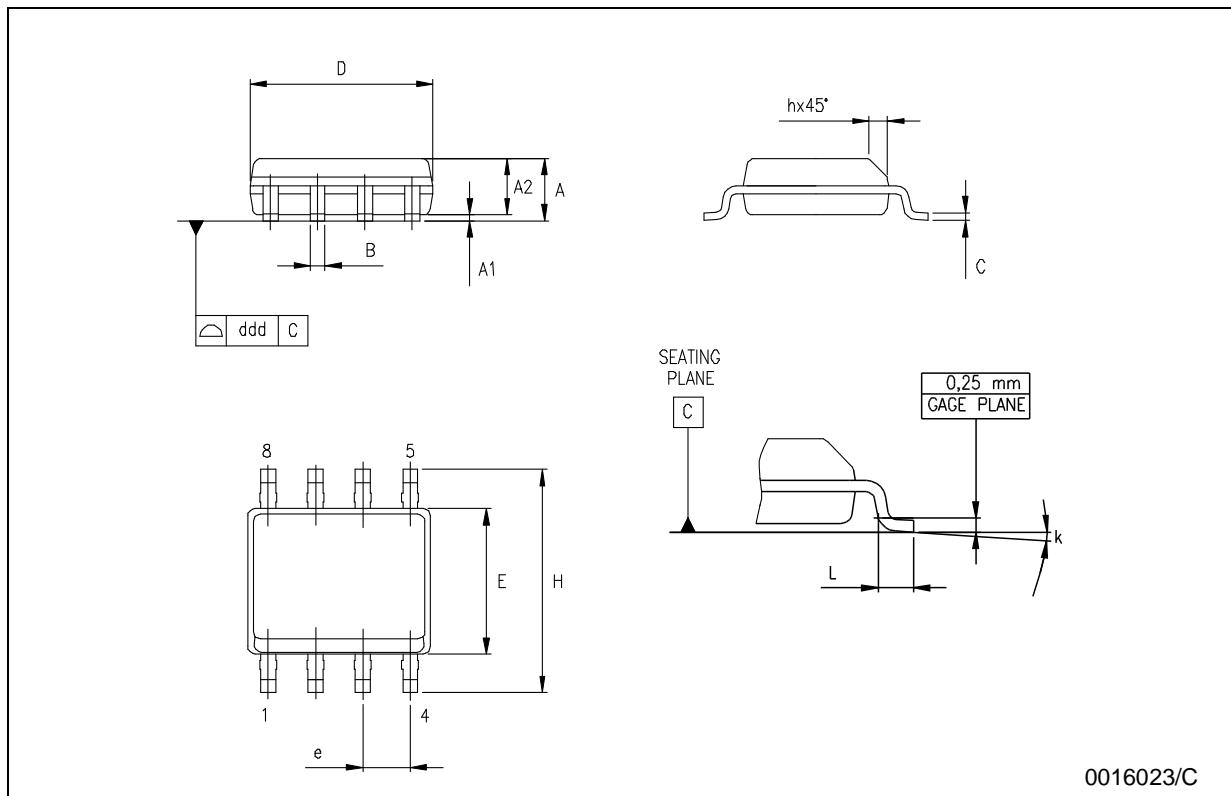

Tape & Reel SO-8 MECHANICAL DATA

DIM.	mm.			inch		
	MIN.	TYP	MAX.	MIN.	TYP.	MAX.
A			330			12.992
C	12.8		13.2	0.504		0.519
D	20.2			0.795		
N	60			2.362		
T			22.4			0.882
Ao	8.1		8.5	0.319		0.335
Bo	5.5		5.9	0.216		0.232
Ko	2.1		2.3	0.082		0.090
Po	3.9		4.1	0.153		0.161
P	7.9		8.1	0.311		0.319

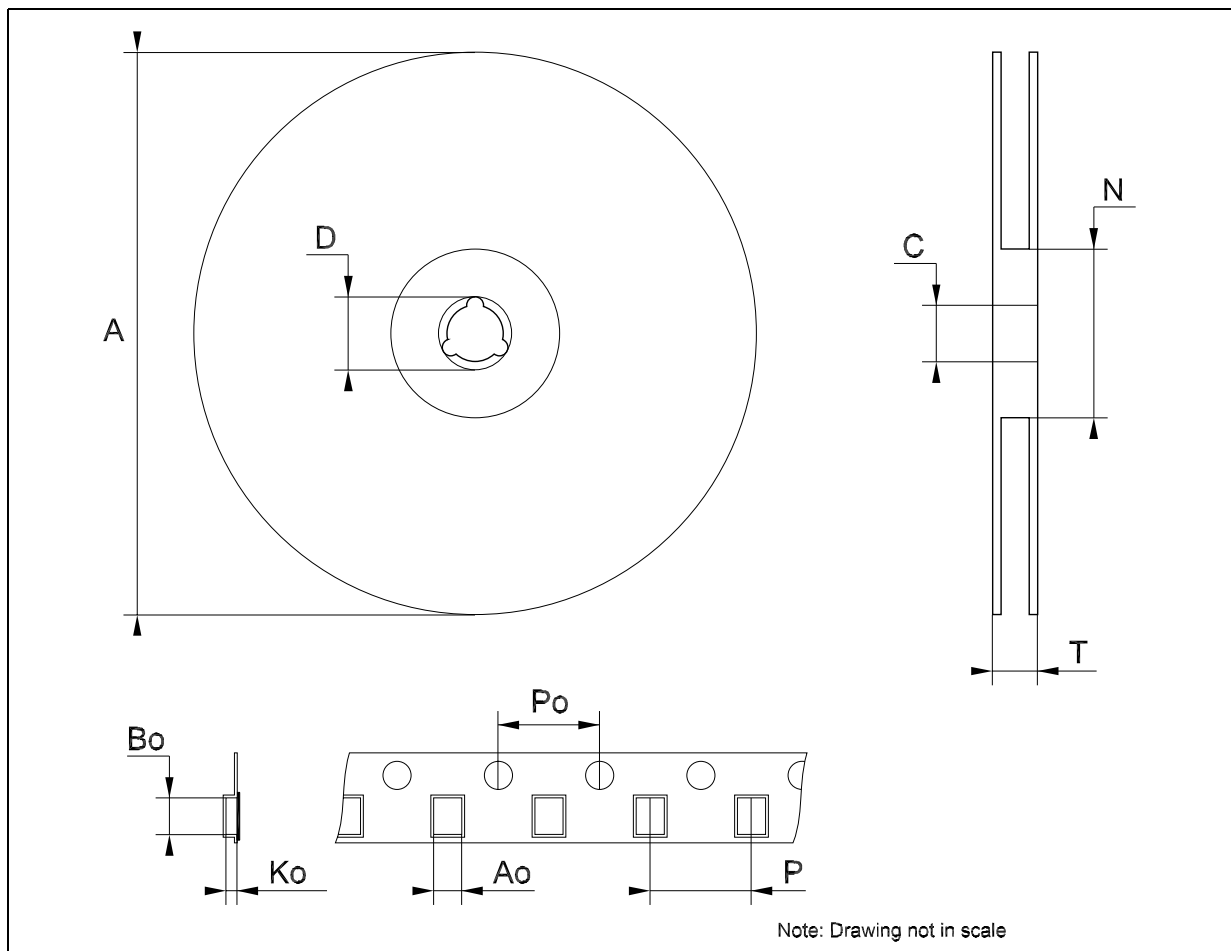

7 Revision history

Table 12. Revision history

Date	Revision	Changes
20-Jun-2005	2	Mistake on table 12 $t_{ZL(SHDN)}$ ms ==> μ s.
30-Aug-2005	3	Remove (TRUE) on title, description has been updated in cover page. The V_{TH} and ΔV_{TH} values are changed in table 10.
07-Apr-2006	4	Order codes has been updated and new template.

Please Read Carefully:

Information in this document is provided solely in connection with ST products. STMicroelectronics NV and its subsidiaries ("ST") reserve the right to make changes, corrections, modifications or improvements, to this document, and the products and services described herein at any time, without notice.

All ST products are sold pursuant to ST's terms and conditions of sale.

Purchasers are solely responsible for the choice, selection and use of the ST products and services described herein, and ST assumes no liability whatsoever relating to the choice, selection or use of the ST products and services described herein.

No license, express or implied, by estoppel or otherwise, to any intellectual property rights is granted under this document. If any part of this document refers to any third party products or services it shall not be deemed a license grant by ST for the use of such third party products or services, or any intellectual property contained therein or considered as a warranty covering the use in any manner whatsoever of such third party products or services or any intellectual property contained therein.

UNLESS OTHERWISE SET FORTH IN ST'S TERMS AND CONDITIONS OF SALE ST DISCLAIMS ANY EXPRESS OR IMPLIED WARRANTY WITH RESPECT TO THE USE AND/OR SALE OF ST PRODUCTS INCLUDING WITHOUT LIMITATION IMPLIED WARRANTIES OF MERCHANTABILITY, FITNESS FOR A PARTICULAR PURPOSE (AND THEIR EQUIVALENTS UNDER THE LAWS OF ANY JURISDICTION), OR INFRINGEMENT OF ANY PATENT, COPYRIGHT OR OTHER INTELLECTUAL PROPERTY RIGHT.

UNLESS EXPRESSLY APPROVED IN WRITING BY AN AUTHORIZED REPRESENTATIVE OF ST, ST PRODUCTS ARE NOT DESIGNED, AUTHORIZED OR WARRANTED FOR USE IN MILITARY, AIR CRAFT, SPACE, LIFE SAVING, OR LIFE SUSTAINING APPLICATIONS, NOR IN PRODUCTS OR SYSTEMS, WHERE FAILURE OR MALFUNCTION MAY RESULT IN PERSONAL INJURY, DEATH, OR SEVERE PROPERTY OR ENVIRONMENTAL DAMAGE.

Resale of ST products with provisions different from the statements and/or technical features set forth in this document shall immediately void any warranty granted by ST for the ST product or service described herein and shall not create or extend in any manner whatsoever, any liability of ST.

ST and the ST logo are trademarks or registered trademarks of ST in various countries.

Information in this document supersedes and replaces all information previously supplied.

The ST logo is a registered trademark of STMicroelectronics. All other names are the property of their respective owners.

© 2006 STMicroelectronics - All rights reserved



STMicroelectronics group of companies

Australia - Belgium - Brazil - Canada - China - Czech Republic - Finland - France - Germany - Hong Kong - India - Israel - Italy - Japan - Malaysia - Malta - Morocco - Singapore - Spain - Sweden - Switzerland - United Kingdom - United States of America

www.st.com

Looking for pricing, stock, or lifecycle information?

Click below to explore more details on WIN SOURCE:

-  [View ST3485EBN](#) on WIN SOURCE
-  [STMicroelectronics](#) Information

Optimize Your Supply Chain with WIN SOURCE Solutions

-  Global Sourcing Solution
-  Obsolete Management
-  Cost Control Management
-  Shortage Management
-  Alternative Solution
-  Excess Inventory Management