



**THE DATASHEET OF  
SN74AHCT1G08DCKT**



## SN74AHCT1G08 Single 2-Input Positive-AND Gate

### 1 Features

- Operating Range: 4.5 V to 5.5 V
- Maximum  $t_{pd}$  of 7.1 ns at 5 V
- Low Power Consumption: Maximum  $I_{CC}$  of 10- $\mu$ A
- $\pm 8$ -mA Output Drive at 5 V
- Inputs Are TTL-Voltage Compatible
- Latch-Up Performance Exceeds 250 mA Per JESD 17

### 2 Applications

- TV, Set-Top Box, and Audio
- Wireless Infrastructure
- Factory Automation and Control
- PC and Notebooks
- Building Automation
- Grid Infrastructure
- Medical, Healthcare, and Fitness
- Printers
- Test and Measurement
- EPOS (Electronic Point of Sale)
- Telecom Infrastructure
- Projectors

### 3 Description

The SN74AHCT1G08 device is a single 2-input positive-AND gate. The device performs the Boolean function  $Y = A \cdot B$  or  $Y = A + B$  in positive logic. Low  $I_{CC}$  current allows this device to be used in power-sensitive or battery-powered applications.

#### Device Information<sup>(1)</sup>

PART NUMBER	PACKAGE	BODY SIZE (NOM)
SN74AHCT1G08DBVR	SOT-23 (5)	2.90 mm x 1.60 mm
SN74AHCT1G08DCKR	SC70 (5)	2.00 mm x 1.25 mm
SN74AHCT1G08DRLR	SOT (5)	1.60 mm x 1.20 mm

(1) For all available packages, see the orderable addendum at the end of the data sheet.

#### Logic Diagram



## Table of Contents

<b>1 Features</b> .....	<b>1</b>	8.2 Functional Block Diagram .....	<b>7</b>
<b>2 Applications</b> .....	<b>1</b>	8.3 Feature Description.....	<b>7</b>
<b>3 Description</b> .....	<b>1</b>	8.4 Device Functional Modes.....	<b>7</b>
<b>4 Revision History</b> .....	<b>2</b>	<b>9 Application and Implementation</b> .....	<b>8</b>
<b>5 Pin Configuration and Functions</b> .....	<b>3</b>	9.1 Application Information.....	<b>8</b>
<b>6 Specifications</b> .....	<b>3</b>	9.2 Typical Application .....	<b>8</b>
6.1 Absolute Maximum Ratings .....	<b>3</b>	<b>10 Power Supply Recommendations</b> .....	<b>9</b>
6.2 ESD Ratings.....	<b>3</b>	<b>11 Layout</b> .....	<b>9</b>
6.3 Recommended Operating Conditions.....	<b>4</b>	11.1 Layout Guidelines .....	<b>9</b>
6.4 Thermal Information .....	<b>4</b>	11.2 Layout Example .....	<b>9</b>
6.5 Electrical Characteristics.....	<b>4</b>	<b>12 Device and Documentation Support</b> .....	<b>10</b>
6.6 Switching Characteristics .....	<b>5</b>	12.1 Documentation Support .....	<b>10</b>
6.7 Operating Characteristics.....	<b>5</b>	12.2 Community Resources.....	<b>10</b>
6.8 Typical Characteristics.....	<b>5</b>	12.3 Trademarks .....	<b>10</b>
<b>7 Parameter Measurement Information</b> .....	<b>6</b>	12.4 Electrostatic Discharge Caution.....	<b>10</b>
<b>8 Detailed Description</b> .....	<b>7</b>	12.5 Glossary .....	<b>10</b>
8.1 Overview .....	<b>7</b>	<b>13 Mechanical, Packaging, and Orderable Information</b> .....	<b>10</b>

## 4 Revision History

NOTE: Page numbers for previous revisions may differ from page numbers in the current version.

<b>Changes from Revision P (May 2013) to Revision Q</b>	<b>Page</b>
<ul style="list-style-type: none"> <li>Added <i>Applications</i> section, <i>Device Information</i> table, <i>Table of Contents</i>, <i>Pin Configuration and Functions</i> section, <i>Specifications</i> section, <i>ESD Ratings</i> table, <i>Thermal Information</i> table, <i>Typical Characteristics</i> section, <i>Detailed Description</i> section, <i>Application and Implementation</i> section, <i>Power Supply Recommendations</i> section, <i>Layout</i> section, <i>Device and Documentation Support</i> section, and <i>Mechanical, Packaging, and Orderable Information</i> section.....</li> </ul>	<b>1</b>

<b>Changes from Revision O (June 2005) to Revision P</b>	<b>Page</b>
<ul style="list-style-type: none"> <li>Extended operating temperature range to 125°C.....</li> </ul>	<b>4</b>

## 5 Pin Configuration and Functions

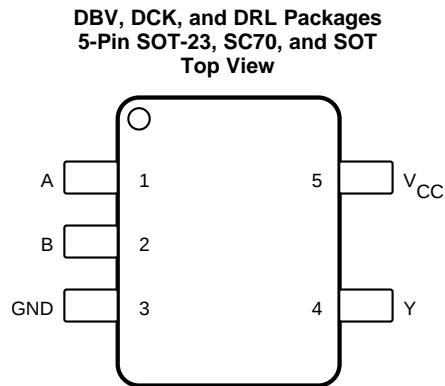

**Pin Functions**

PIN		I/O	DESCRIPTION
NAME	NO.		
A	1	I	Input A
B	2	I	Input B
GND	3	—	Ground Pin
V <sub>CC</sub>	5	—	Supply Pin
Y	4	O	Output

## 6 Specifications

### 6.1 Absolute Maximum Ratings

over operating free-air temperature range (unless otherwise noted).<sup>(1)</sup>

	MIN	MAX	UNIT
Supply voltage	-0.5	7	V
Input voltage <sup>(2)</sup>	-0.5	7	V
Output voltage <sup>(2)</sup>	-0.5	V <sub>CC</sub> + 0.5	V
Input clamp current	V <sub>I</sub> < 0	-20	mA
Output clamp current	V <sub>O</sub> < 0 or V <sub>O</sub> > V <sub>CC</sub>	±20	mA
Continuous output current	V <sub>O</sub> = 0 to V <sub>CC</sub>	±25	mA
Continuous current through V <sub>CC</sub> or GND		±50	mA
Maximum junction temperature, T <sub>J</sub>		150	°C
Storage temperature, T <sub>stg</sub>	-65	150	°C

- (1) Stresses beyond those listed under *Absolute Maximum Ratings* may cause permanent damage to the device. These are stress ratings only, which do not imply functional operation of the device at these or any other conditions beyond those indicated under *Recommended Operating Conditions*. Exposure to absolute-maximum-rated conditions for extended periods may affect device reliability.
- (2) The input and output voltage ratings may be exceeded if the input and output current ratings are observed.

### 6.2 ESD Ratings

	VALUE	UNIT
V <sub>(ESD)</sub> Electrostatic discharge	Human-body model (HBM), per ANSI/ESDA/JEDEC JS-001 <sup>(1)</sup>	±2500
	Charged-device model (CDM), per JEDEC specification JESD22-C101 <sup>(2)</sup>	±1000

- (1) JEDEC document JEP155 states that 500-V HBM allows safe manufacturing with a standard ESD control process.
- (2) JEDEC document JEP157 states that 250-V CDM allows safe manufacturing with a standard ESD control process.

## SN74AHCT1G08

SCLS315Q –MARCH 1996–REVISED APRIL 2016

www.ti.com

### 6.3 Recommended Operating Conditions

over operating free-air temperature range (unless otherwise noted)<sup>(1)</sup>

		MIN	MAX	UNIT
V <sub>CC</sub>	Supply voltage	4.5	5.5	V
V <sub>IH</sub>	High-level input voltage	2		V
V <sub>IL</sub>	Low-level input voltage		0.8	V
V <sub>I</sub>	Input voltage	0	5.5	V
V <sub>O</sub>	Output voltage	0	V <sub>CC</sub>	V
I <sub>OH</sub>	High-level output current		–8	mA
I <sub>OL</sub>	Low-level output current		8	mA
Δt/Δv	Input transition rise and fall rate		20	ns/V
T <sub>A</sub>	Operating free-air temperature	–40	125	°C

(1) All unused inputs of the device must be held at V<sub>CC</sub> or GND to ensure proper device operation. See TI application report, *Implications of Slow or Floating CMOS Inputs (SCBA004)*.

### 6.4 Thermal Information

THERMAL METRIC <sup>(1)</sup>	SN74AHCT1G08			UNIT	
	DBV (SOT-23)	DCK (SC70)	DRL (SOT)		
	5 PINS	5 PINS	5 PINS		
R <sub>θJA</sub>	Junction-to-ambient thermal resistance	226	277.5	242.9	°C/W
R <sub>θJC(top)</sub>	Junction-to-case (top) thermal resistance	165	92.9	77.5	°C/W
R <sub>θJB</sub>	Junction-to-board thermal resistance	59.1	64.2	77.5	°C/W
Ψ <sub>JT</sub>	Junction-to-top characterization parameter	45.5	1.9	9.6	°C/W
Ψ <sub>JB</sub>	Junction-to-board characterization parameter	58.3	63.5	77.3	°C/W

(1) For more information about traditional and new thermal metrics, see the *Semiconductor and IC Package Thermal Metrics* application report, [SPRA953](#).

### 6.5 Electrical Characteristics

over operating free-air temperature range (unless otherwise noted)

PARAMETER	TEST CONDITIONS	MIN	TYP	MAX	UNIT
V <sub>OH</sub>	I <sub>OH</sub> = –50 μA, V <sub>CC</sub> = 4.5 V	T <sub>A</sub> = 25°C	4.4	4.5	V
		T <sub>A</sub> = –40°C to 125°C	4.4		
	I <sub>OH</sub> = –8 mA, V <sub>CC</sub> = 4.5 V	T <sub>A</sub> = 25°C	3.94		
		T <sub>A</sub> = –40°C to 125°C	3.8		
V <sub>OL</sub>	I <sub>OL</sub> = 50 μA, V <sub>CC</sub> = 4.5 V			0.1	V
	I <sub>OL</sub> = 8 mA, V <sub>CC</sub> = 4.5 V	T <sub>A</sub> = 25°C		0.36	
		T <sub>A</sub> = –40°C to 125°C		0.44	
I <sub>I</sub>	V <sub>I</sub> = 5.5 V or GND, V <sub>CC</sub> = 0 V to 5.5 V	T <sub>A</sub> = 25°C		±0.1	μA
		T <sub>A</sub> = –40°C to 125°C		±1	
I <sub>CC</sub>	V <sub>I</sub> = V <sub>CC</sub> or GND, I <sub>O</sub> = 0, V <sub>CC</sub> = 5.5 V	T <sub>A</sub> = 25°C		1	μA
		T <sub>A</sub> = –40°C to 125°C		10	
ΔI <sub>CC</sub> <sup>(1)</sup>	One input at 3.4 V, Other Inputs at V <sub>CC</sub> or GND, V <sub>CC</sub> = 5.5 V	T <sub>A</sub> = 25°C		1.35	mA
		T <sub>A</sub> = –40°C to 125°C		1.5	
C <sub>I</sub>	V <sub>I</sub> = V <sub>CC</sub> or GND, V <sub>CC</sub> = 5 V		4	10	pF

(1) This is the increase in supply current for each input at one of the specified TTL voltage levels, rather than 0 V or V<sub>CC</sub>.

### 6.6 Switching Characteristics

over recommended operating free-air temperature range,  $V_{CC} = 5 V \pm 0.5 V$  (unless otherwise noted) (see Figure 2)

PARAMETER	FROM (INPUT)	TO (OUTPUT)	OUTPUT CAPACITANCE	TEST CONDITIONS	MIN	TYP	MAX	UNIT
$t_{PLH}$ Propagation delay, low to high transition	A or B	Y	$C_L = 15 \text{ pF}$	$T_A = 25^\circ\text{C}$		5	6.2	ns
				$T_A = -40^\circ\text{C to } 85^\circ\text{C}$	1		7.1	
				$T_A = -40^\circ\text{C to } 125^\circ\text{C}$	1		7.5	
$t_{PHL}$ Propagation delay, high to low transition	A or B	Y	$C_L = 15 \text{ pF}$	$T_A = 25^\circ\text{C}$		5	6.2	ns
				$T_A = -40^\circ\text{C to } 85^\circ\text{C}$	1		7.1	
				$T_A = -40^\circ\text{C to } 125^\circ\text{C}$	1		7.5	
$t_{PLH}$ Propagation delay, low to high transition	A or B	Y	$C_L = 50 \text{ pF}$	$T_A = 25^\circ\text{C}$		5.5	7.9	ns
				Propagation delay, high to low transition	1		9	
				$T_A = -40^\circ\text{C to } 125^\circ\text{C}$	1		10	
$t_{PHL}$ Propagation delay, high to low transition	A or B	Y	$C_L = 50 \text{ pF}$	$T_A = 25^\circ\text{C}$		5.5	7.9	ns
				$T_A = -40^\circ\text{C to } 85^\circ\text{C}$	1		9	
				$T_A = -40^\circ\text{C to } 125^\circ\text{C}$	1		10	

### 6.7 Operating Characteristics

$V_{CC} = 5 V, T_A = 25^\circ\text{C}$

PARAMETER	TEST CONDITIONS	TYP	UNIT
$C_{pd}$ Power dissipation capacitance	No load, $f = 1 \text{ MHz}$	18	pF

### 6.8 Typical Characteristics

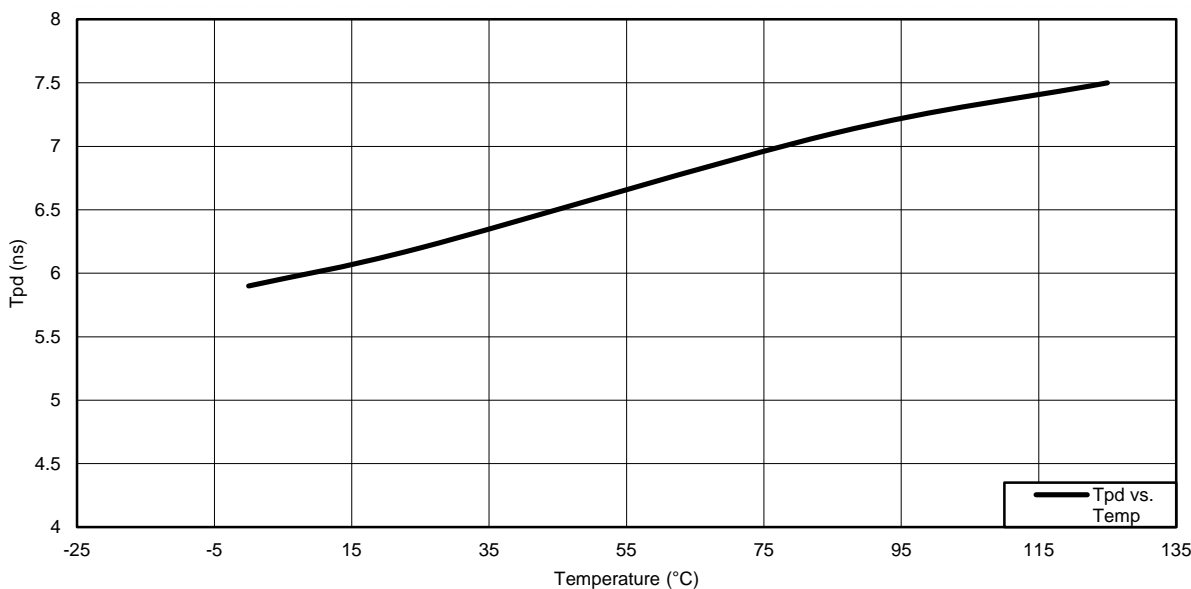

$C_L = 15 \text{ pF}$

Figure 1.  $T_{pd}$  vs Temperature

## 7 Parameter Measurement Information

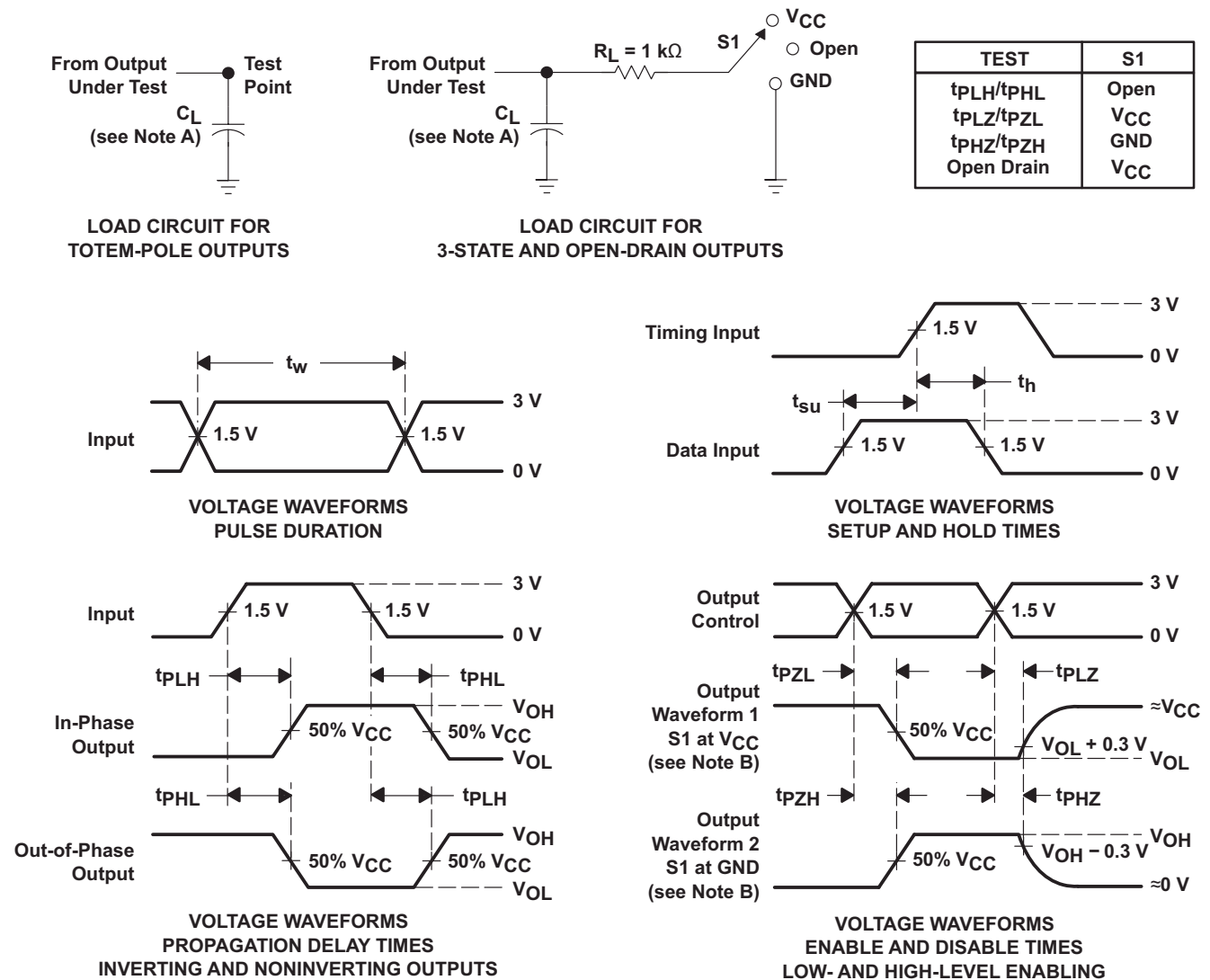

$C_L$  includes probe and jig capacitance.

Waveform 1 is for an output with internal conditions such that the output is low except when disabled by the output control.

Waveform 2 is for an output with internal conditions such that the output is high except when disabled by the output control.

All input pulses are supplied by generators having the following characteristics:  $PRR \leq 1\text{ MHz}$ ,  $Z_O = 50\ \Omega$ ,  $t_r \leq 3\text{ ns}$ ,  $t_f \leq 3\text{ ns}$ .

The outputs are measured one at a time with one input transition per measurement.

All parameters and waveforms are not applicable to all devices.

**Figure 2. Load Circuit and Voltage Waveforms**

## 8 Detailed Description

### 8.1 Overview

The SN74AHCT1G08 device is a single 2-input positive-AND gate. The device performs the Boolean AND function ( $Y = A \cdot B$  or  $Y = A + B$ ) in positive logic. Low  $I_{CC}$  current allows this device to be used in power-sensitive or battery-powered applications. Robust inputs allow the device to up-translate with a propagation delay of 20 ns.

### 8.2 Functional Block Diagram



Figure 3. Logic Diagram (Positive Logic)

### 8.3 Feature Description

The  $V_{CC}$  for the device is optimized at 5 V.

Up voltage translation from 3.3 V to 5 V is allowed. The inputs accept  $V_{IH}$  levels of 2 V.

Output ringing is minimized by slow edge rates.

Inputs are TTL-Voltage compatible.

### 8.4 Device Functional Modes

Table 1 lists the functional modes of the SN74AHCT1G08.

Table 1. Function Table

INPUTS		OUTPUT
A	B	Y
H	H	H
L	X	L
X	L	L

## 9 Application and Implementation

### NOTE

Information in the following applications sections is not part of the TI component specification, and TI does not warrant its accuracy or completeness. TI's customers are responsible for determining suitability of components for their purposes. Customers should validate and test their design implementation to confirm system functionality.

### 9.1 Application Information

The SN74AHCT1G08 device is a single AND gate, which is often used for many common functions like power sequencing or an *on* LED indicator. Because the device is configured to output LOW unless all inputs are HIGH, an LED tied to the output of the device will only turn HIGH when all systems connected are sending a HIGH, or *ready* signal.

### 9.2 Typical Application

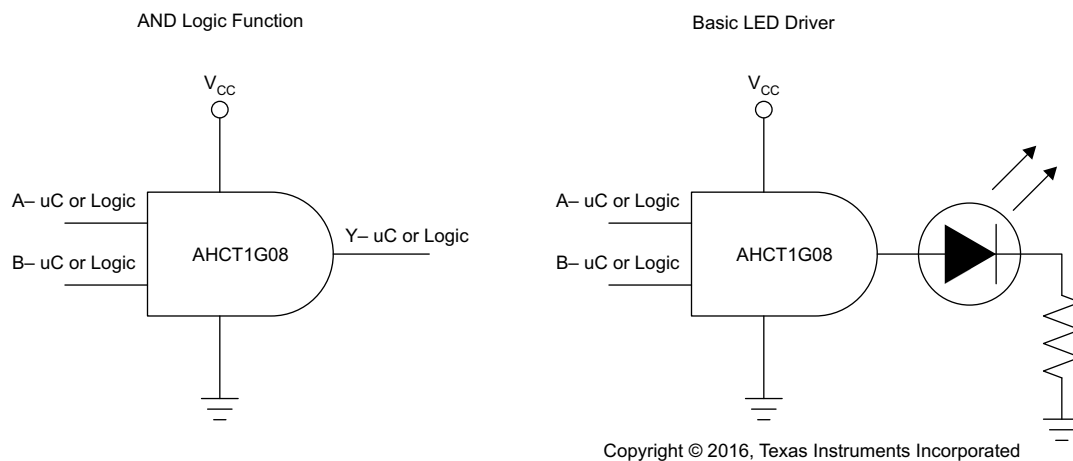

**Figure 4. Typical Application Diagram**

#### 9.2.1 Design Requirements

This device uses CMOS technology and has balanced output drive. Take care to avoid bus contention because it can drive currents that would exceed maximum limits. The high drive also creates fast edges into light loads, so routing and load conditions must be considered to prevent ringing.

#### 9.2.2 Detailed Design Procedure

1. Recommended Input Conditions
  - For rise time and fall time specifications, see  $\Delta t/\Delta V$  in [Recommended Operating Conditions](#).
  - For specified high and low levels, see  $V_{IH}$  and  $V_{IL}$  in [Recommended Operating Conditions](#).
  - Inputs are overvoltage tolerant allowing them to go as high as 5.5 V at any valid  $V_{CC}$ .
2. Recommended Output Conditions
  - Load currents must not exceed 25 mA per output and 50 mA total for the part.
  - Outputs must not be pulled above  $V_{CC}$ .

## Typical Application (continued)

### 9.2.3 Application Curve

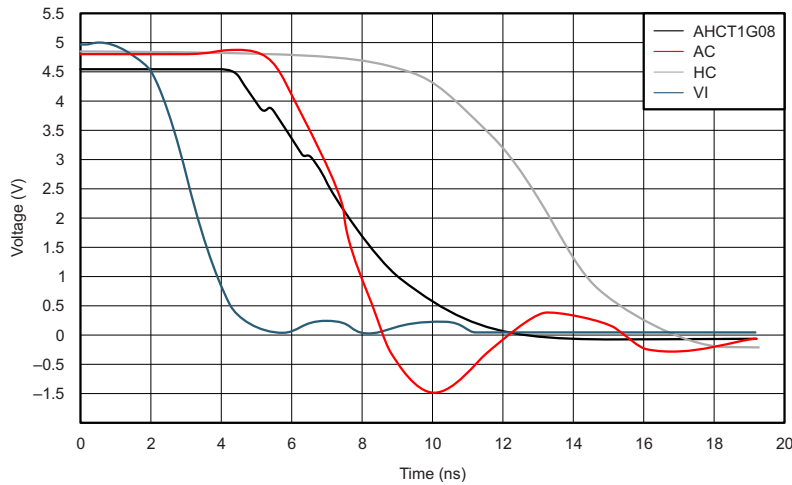

$V_{CC} = 5\text{ V}$

Load =  $50\ \Omega / 50\text{ pF}$

Figure 5. Typical Switching Characteristics

## 10 Power Supply Recommendations

The power supply can be any voltage between the minimum and maximum supply voltage rating located in [Recommended Operating Conditions](#).

Each  $V_{CC}$  pin must have a good bypass capacitor to prevent power disturbance. TI recommends a  $0.1\text{-}\mu\text{F}$  capacitor for devices with a single supply; and a  $0.01\text{-}\mu\text{F}$  or  $0.022\text{-}\mu\text{F}$  capacitor for each power pin if there are multiple  $V_{CC}$  pins. It is ok to parallel multiple bypass capacitors to reject different frequencies of noise.  $0.1\text{-}\mu\text{F}$  and  $1\text{-}\mu\text{F}$  capacitors are commonly used in parallel. The bypass capacitor must be installed as close to the power pin as possible for best results.

## 11 Layout

### 11.1 Layout Guidelines

When using multiple bit logic devices inputs must not ever float. In many cases, functions or parts of functions of digital logic devices are unused; for example, when only two inputs of a triple-input AND gate are used or only 3 of the 4 buffer gates are used. Such input pins must not be left unconnected because the undefined voltages at the outside connections result in undefined operational states. Observe the following rules under all circumstances.

- All unused inputs of digital logic devices must be connected to a high or low bias to prevent them from floating.
- The logic level that must be applied to any particular unused input depends on the function of the device. Generally they will be tied to GND or  $V_{CC}$ , whichever make more sense or is more convenient.

### 11.2 Layout Example

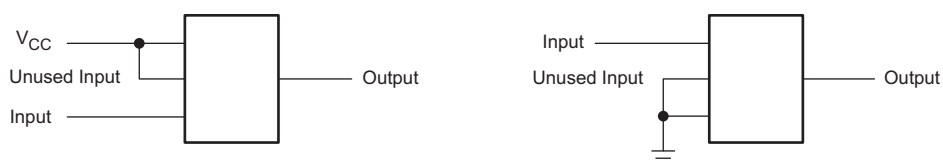

Figure 6. Layout Diagram

## 12 Device and Documentation Support

### 12.1 Documentation Support

#### 12.1.1 Related Documentation

For related documentation, see the following:

*Implications of Slow or Floating CMOS Inputs*, [SCBA004](#)

### 12.2 Community Resources

The following links connect to TI community resources. Linked contents are provided "AS IS" by the respective contributors. They do not constitute TI specifications and do not necessarily reflect TI's views; see TI's [Terms of Use](#).

**TI E2E™ Online Community** *TI's Engineer-to-Engineer (E2E) Community*. Created to foster collaboration among engineers. At [e2e.ti.com](#), you can ask questions, share knowledge, explore ideas and help solve problems with fellow engineers.

**Design Support** *TI's Design Support* Quickly find helpful E2E forums along with design support tools and contact information for technical support.

### 12.3 Trademarks

E2E is a trademark of Texas Instruments.

All other trademarks are the property of their respective owners.

### 12.4 Electrostatic Discharge Caution



This integrated circuit can be damaged by ESD. Texas Instruments recommends that all integrated circuits be handled with appropriate precautions. Failure to observe proper handling and installation procedures can cause damage.

ESD damage can range from subtle performance degradation to complete device failure. Precision integrated circuits may be more susceptible to damage because very small parametric changes could cause the device not to meet its published specifications.

### 12.5 Glossary

[SLYZ022](#) — *TI Glossary*.

This glossary lists and explains terms, acronyms, and definitions.

## 13 Mechanical, Packaging, and Orderable Information

The following pages include mechanical packaging and orderable information. This information is the most current data available for the designated devices. This data is subject to change without notice and revision of this document. For browser based versions of this data sheet, refer to the left hand navigation.

**PACKAGING INFORMATION**

Orderable Device	Status (1)	Package Type	Package Drawing	Pins	Package Qty	Eco Plan (2)	Lead/Ball Finish (6)	MSL Peak Temp (3)	Op Temp (°C)	Device Marking (4/5)	Samples
74AHCT1G08DBVRE4	ACTIVE	SOT-23	DBV	5	3000	Green (RoHS & no Sb/Br)	CU NIPDAU	Level-1-260C-UNLIM	-40 to 125	B08G	<a href="#">Samples</a>
74AHCT1G08DBVRG4	ACTIVE	SOT-23	DBV	5	3000	Green (RoHS & no Sb/Br)	CU NIPDAU	Level-1-260C-UNLIM	-40 to 125	B08G	<a href="#">Samples</a>
74AHCT1G08DCKRE4	ACTIVE	SC70	DCK	5	3000	Green (RoHS & no Sb/Br)	CU NIPDAU	Level-1-260C-UNLIM	-40 to 125	(BE3, BEG, BEJ, BEL, BES)	<a href="#">Samples</a>
74AHCT1G08DCKRG4	ACTIVE	SC70	DCK	5	3000	Green (RoHS & no Sb/Br)	CU NIPDAU	Level-1-260C-UNLIM	-40 to 125	(BE3, BEG, BEJ, BEL, BES)	<a href="#">Samples</a>
74AHCT1G08DCKTG4	ACTIVE	SC70	DCK	5	250	Green (RoHS & no Sb/Br)	CU NIPDAU	Level-1-260C-UNLIM	-40 to 125	(BE3, BEG, BEL, BES)	<a href="#">Samples</a>
74AHCT1G08DRLRG4	ACTIVE	SOT-5X3	DRL	5	4000	Green (RoHS & no Sb/Br)	CU NIPDAU	Level-1-260C-UNLIM	-40 to 125	(BEB, BES)	<a href="#">Samples</a>
SN74AHCT1G08DBV3	ACTIVE	SOT-23	DBV	5	3000	Pb-Free (RoHS)	CU SNBI	Level-1-260C-UNLIM	-40 to 125	B08Y	<a href="#">Samples</a>
SN74AHCT1G08DBVR	ACTIVE	SOT-23	DBV	5	3000	Green (RoHS & no Sb/Br)	CU NIPDAU   CU SN	Level-1-260C-UNLIM	-40 to 125	(B083, B08G, B08J, B08L, B08S)	<a href="#">Samples</a>
SN74AHCT1G08DBVT	ACTIVE	SOT-23	DBV	5	250	Green (RoHS & no Sb/Br)	CU NIPDAU   CU SN	Level-1-260C-UNLIM	-40 to 125	(B083, B08G, B08J, B08L, B08S)	<a href="#">Samples</a>
SN74AHCT1G08DCK3	ACTIVE	SC70	DCK	5	3000	Pb-Free (RoHS)	CU SNBI	Level-1-260C-UNLIM	-40 to 125	BEY	<a href="#">Samples</a>
SN74AHCT1G08DCKR	ACTIVE	SC70	DCK	5	3000	Green (RoHS & no Sb/Br)	CU NIPDAU	Level-1-260C-UNLIM	-40 to 125	(BE3, BEG, BEJ, BEL, BES)	<a href="#">Samples</a>
SN74AHCT1G08DCKT	ACTIVE	SC70	DCK	5	250	Green (RoHS & no Sb/Br)	CU NIPDAU	Level-1-260C-UNLIM	-40 to 125	(BE3, BEG, BEL, BES)	<a href="#">Samples</a>
SN74AHCT1G08DRLR	ACTIVE	SOT-5X3	DRL	5	4000	Green (RoHS & no Sb/Br)	CU NIPDAU   CU NIPDAUAG	Level-1-260C-UNLIM	-40 to 125	(BEB, BES)	<a href="#">Samples</a>

(1) The marketing status values are defined as follows:

**ACTIVE:** Product device recommended for new designs.

**LIFEBUY:** TI has announced that the device will be discontinued, and a lifetime-buy period is in effect.

**NRND:** Not recommended for new designs. Device is in production to support existing customers, but TI does not recommend using this part in a new design.

**PREVIEW:** Device has been announced but is not in production. Samples may or may not be available.

**OBSOLETE:** TI has discontinued the production of the device.

(2) **RoHS:** TI defines "RoHS" to mean semiconductor products that are compliant with the current EU RoHS requirements for all 10 RoHS substances, including the requirement that RoHS substance do not exceed 0.1% by weight in homogeneous materials. Where designed to be soldered at high temperatures, "RoHS" products are suitable for use in specified lead-free processes. TI may reference these types of products as "Pb-Free".

**RoHS Exempt:** TI defines "RoHS Exempt" to mean products that contain lead but are compliant with EU RoHS pursuant to a specific EU RoHS exemption.

**Green:** TI defines "Green" to mean the content of Chlorine (Cl) and Bromine (Br) based flame retardants meet JS709B low halogen requirements of  $\leq 1000$ ppm threshold. Antimony trioxide based flame retardants must also meet the  $\leq 1000$ ppm threshold requirement.

(3) MSL, Peak Temp. - The Moisture Sensitivity Level rating according to the JEDEC industry standard classifications, and peak solder temperature.

(4) There may be additional marking, which relates to the logo, the lot trace code information, or the environmental category on the device.

(5) Multiple Device Markings will be inside parentheses. Only one Device Marking contained in parentheses and separated by a "~" will appear on a device. If a line is indented then it is a continuation of the previous line and the two combined represent the entire Device Marking for that device.

(6) Lead/Ball Finish - Orderable Devices may have multiple material finish options. Finish options are separated by a vertical ruled line. Lead/Ball Finish values may wrap to two lines if the finish value exceeds the maximum column width.

**Important Information and Disclaimer:** The information provided on this page represents TI's knowledge and belief as of the date that it is provided. TI bases its knowledge and belief on information provided by third parties, and makes no representation or warranty as to the accuracy of such information. Efforts are underway to better integrate information from third parties. TI has taken and continues to take reasonable steps to provide representative and accurate information but may not have conducted destructive testing or chemical analysis on incoming materials and chemicals. TI and TI suppliers consider certain information to be proprietary, and thus CAS numbers and other limited information may not be available for release.

In no event shall TI's liability arising out of such information exceed the total purchase price of the TI part(s) at issue in this document sold by TI to Customer on an annual basis.

## TAPE AND REEL INFORMATION



### QUADRANT ASSIGNMENTS FOR PIN 1 ORIENTATION IN TAPE



\*All dimensions are nominal

Device	Package Type	Package Drawing	Pins	SPQ	Reel Diameter (mm)	Reel Width W1 (mm)	A0 (mm)	B0 (mm)	K0 (mm)	P1 (mm)	W (mm)	Pin1 Quadrant
74AHCT1G08DBVRG4	SOT-23	DBV	5	3000	178.0	9.0	3.23	3.17	1.37	4.0	8.0	Q3
SN74AHCT1G08DBVR	SOT-23	DBV	5	3000	178.0	9.0	3.23	3.17	1.37	4.0	8.0	Q3
SN74AHCT1G08DBVR	SOT-23	DBV	5	3000	178.0	9.2	3.3	3.23	1.55	4.0	8.0	Q3
SN74AHCT1G08DBVR	SOT-23	DBV	5	3000	180.0	8.4	3.23	3.17	1.37	4.0	8.0	Q3
SN74AHCT1G08DBVR	SOT-23	DBV	5	3000	178.0	9.0	3.3	3.2	1.4	4.0	8.0	Q3
SN74AHCT1G08DBVT	SOT-23	DBV	5	250	178.0	9.0	3.23	3.17	1.37	4.0	8.0	Q3
SN74AHCT1G08DBVT	SOT-23	DBV	5	250	178.0	9.0	3.3	3.2	1.4	4.0	8.0	Q3
SN74AHCT1G08DCKR	SC70	DCK	5	3000	178.0	9.0	2.4	2.5	1.2	4.0	8.0	Q3
SN74AHCT1G08DCKR	SC70	DCK	5	3000	180.0	8.4	2.47	2.3	1.25	4.0	8.0	Q3
SN74AHCT1G08DCKT	SC70	DCK	5	250	178.0	9.0	2.4	2.5	1.2	4.0	8.0	Q3
SN74AHCT1G08DCKT	SC70	DCK	5	250	178.0	9.2	2.4	2.4	1.22	4.0	8.0	Q3
SN74AHCT1G08DCKT	SC70	DCK	5	250	180.0	9.2	2.3	2.55	1.2	4.0	8.0	Q3
SN74AHCT1G08DRLR	SOT-5X3	DRL	5	4000	180.0	8.4	1.98	1.78	0.69	4.0	8.0	Q3

**TAPE AND REEL BOX DIMENSIONS**

\*All dimensions are nominal

Device	Package Type	Package Drawing	Pins	SPQ	Length (mm)	Width (mm)	Height (mm)
74AHCT1G08DBVRG4	SOT-23	DBV	5	3000	180.0	180.0	18.0
SN74AHCT1G08DBVR	SOT-23	DBV	5	3000	180.0	180.0	18.0
SN74AHCT1G08DBVR	SOT-23	DBV	5	3000	180.0	180.0	18.0
SN74AHCT1G08DBVR	SOT-23	DBV	5	3000	202.0	201.0	28.0
SN74AHCT1G08DBVR	SOT-23	DBV	5	3000	180.0	180.0	18.0
SN74AHCT1G08DBVT	SOT-23	DBV	5	250	180.0	180.0	18.0
SN74AHCT1G08DBVT	SOT-23	DBV	5	250	180.0	180.0	18.0
SN74AHCT1G08DCKR	SC70	DCK	5	3000	180.0	180.0	18.0
SN74AHCT1G08DCKR	SC70	DCK	5	3000	202.0	201.0	28.0
SN74AHCT1G08DCKT	SC70	DCK	5	250	180.0	180.0	18.0
SN74AHCT1G08DCKT	SC70	DCK	5	250	180.0	180.0	18.0
SN74AHCT1G08DCKT	SC70	DCK	5	250	205.0	200.0	33.0
SN74AHCT1G08DRLR	SOT-5X3	DRL	5	4000	202.0	201.0	28.0

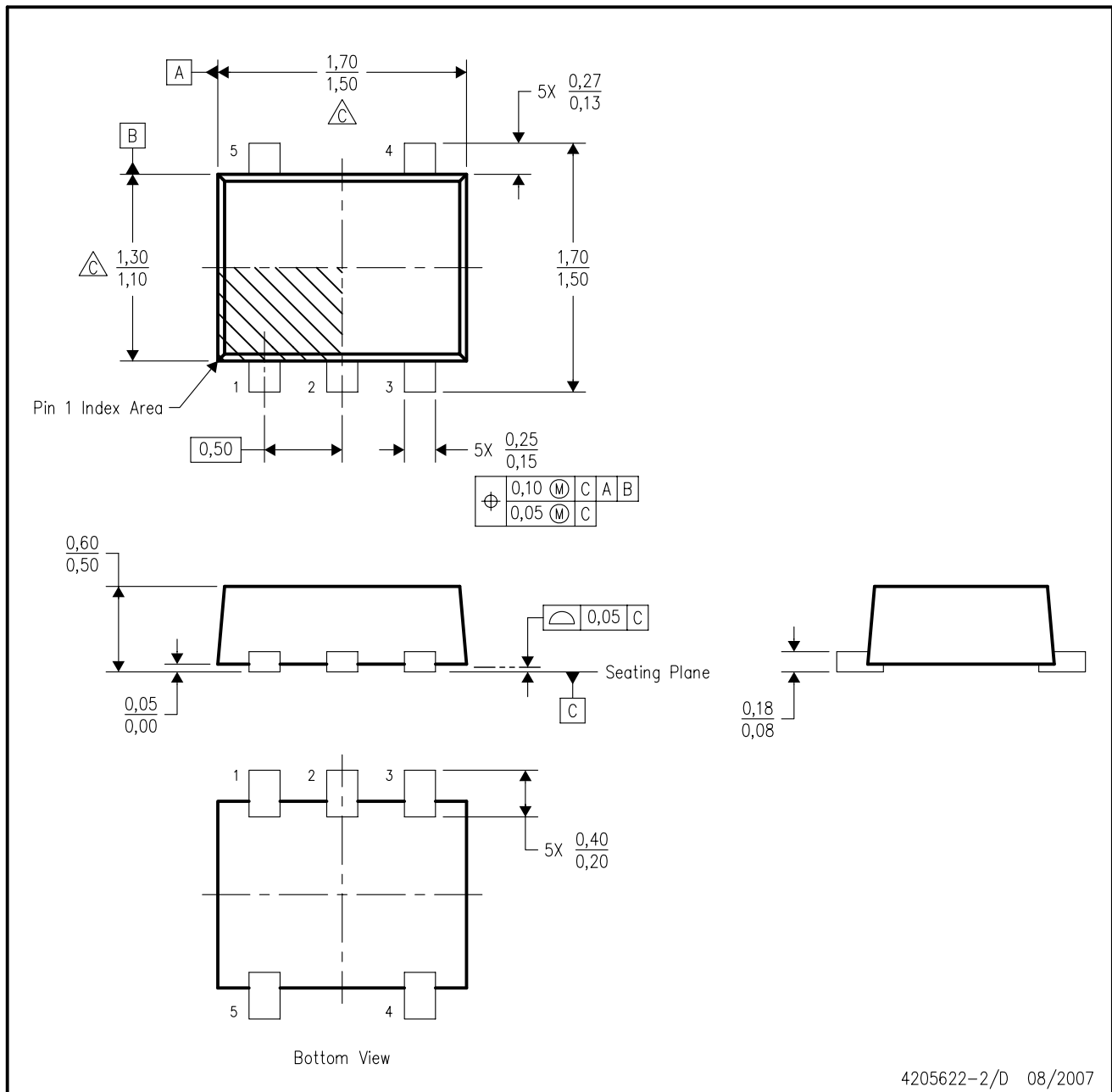

- NOTES:
- A. All linear dimensions are in millimeters. Dimensioning and tolerancing per ASME Y14.5M-1994.
  - B. This drawing is subject to change without notice.
  - C. Body dimensions do not include mold flash, interlead flash, protrusions, or gate burrs. Mold flash, interlead flash, protrusions, or gate burrs shall not exceed 0,15 per end or side.
  - D. JEDEC package registration is pending.

DRL (R-PDSO-N5)

PLASTIC SMALL OUTLINE

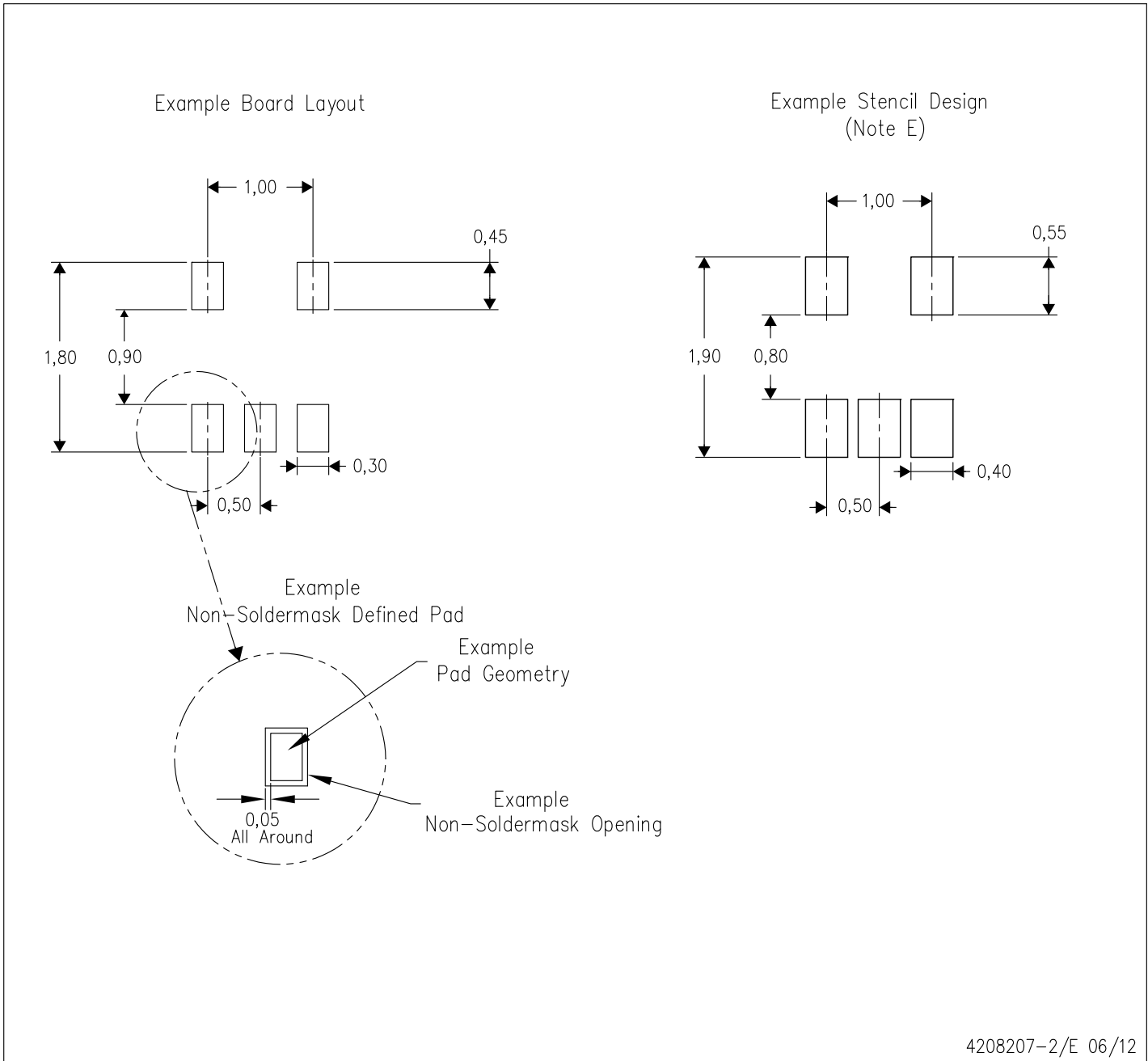

- NOTES:
- A. All linear dimensions are in millimeters.
  - B. This drawing is subject to change without notice.
  - C. Publication IPC-7351 is recommended for alternate designs.
  - D. Customers should contact their board fabrication site for minimum solder mask web tolerances between signal pads.
  - E. Maximum stencil thickness 0,127 mm (5 mils). All linear dimensions are in millimeters.
  - F. Laser cutting apertures with trapezoidal walls and also rounding corners will offer better paste release. Customers should contact their board assembly site for stencil design recommendations. Refer to IPC 7525 for stencil design considerations.
  - G. Side aperture dimensions over-print land for acceptable area ratio > 0.66. Customer may reduce side aperture dimensions if stencil manufacturing process allows for sufficient release at smaller opening.

DBV0005A



# PACKAGE OUTLINE

SOT-23 - 1.45 mm max height

SMALL OUTLINE TRANSISTOR



4214839/D 11/2018

## NOTES:

1. All linear dimensions are in millimeters. Any dimensions in parenthesis are for reference only. Dimensioning and tolerancing per ASME Y14.5M.
2. This drawing is subject to change without notice.
3. Reference JEDEC MO-178.
4. Body dimensions do not include mold flash, protrusions, or gate burrs. Mold flash, protrusions, or gate burrs shall not exceed 0.15 mm per side.

# EXAMPLE BOARD LAYOUT

DBV0005A

SOT-23 - 1.45 mm max height

SMALL OUTLINE TRANSISTOR



LAND PATTERN EXAMPLE  
EXPOSED METAL SHOWN  
SCALE:15X



SOLDER MASK DETAILS

4214839/D 11/2018

NOTES: (continued)

- 5. Publication IPC-7351 may have alternate designs.
- 6. Solder mask tolerances between and around signal pads can vary based on board fabrication site.

# EXAMPLE STENCIL DESIGN

DBV0005A

SOT-23 - 1.45 mm max height

SMALL OUTLINE TRANSISTOR



SOLDER PASTE EXAMPLE  
BASED ON 0.125 mm THICK STENCIL  
SCALE:15X

4214839/D 11/2018

NOTES: (continued)

7. Laser cutting apertures with trapezoidal walls and rounded corners may offer better paste release. IPC-7525 may have alternate design recommendations.
8. Board assembly site may have different recommendations for stencil design.



DCK (R-PDSO-G5)

PLASTIC SMALL OUTLINE

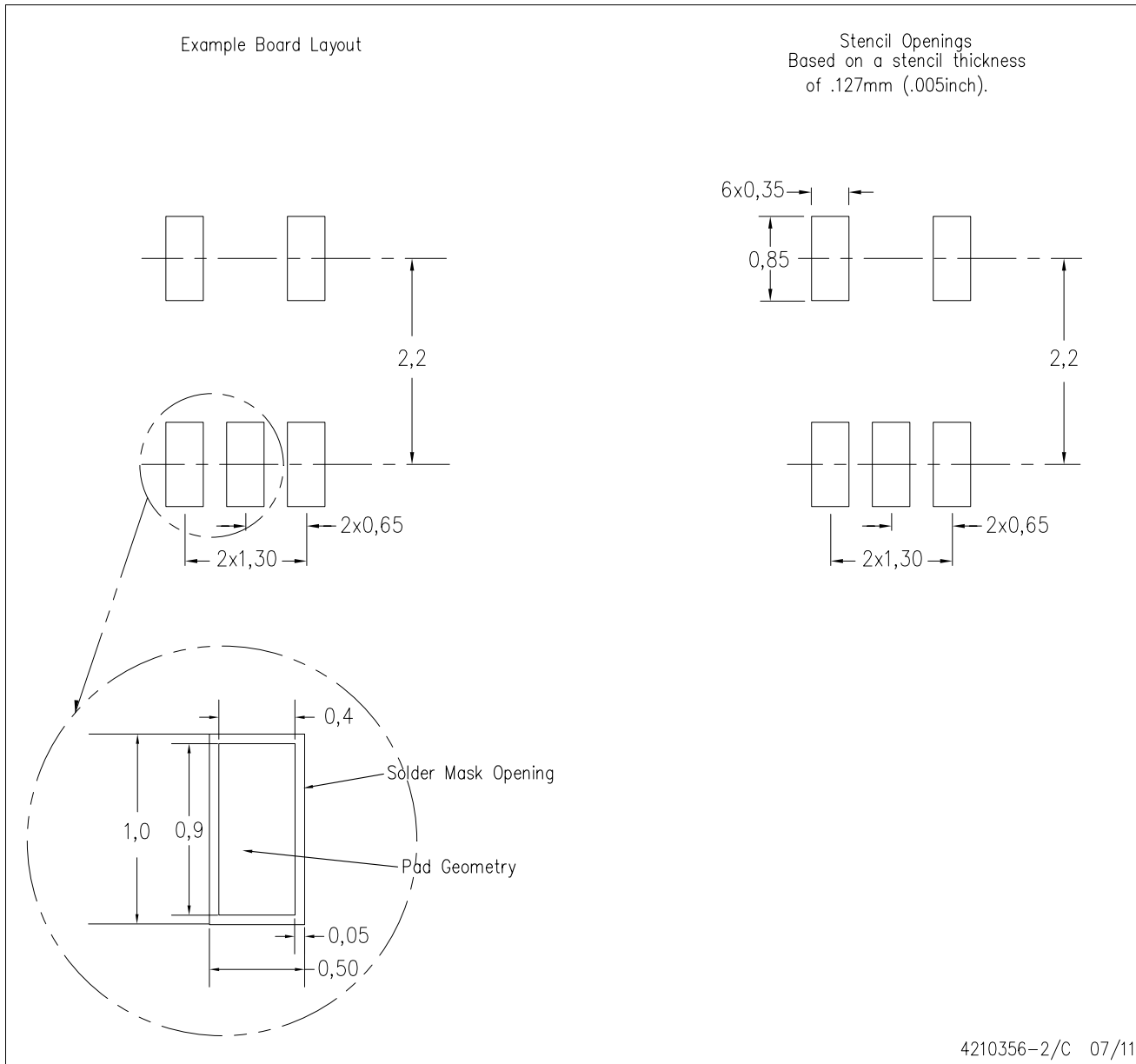

- NOTES:
- All linear dimensions are in millimeters.
  - This drawing is subject to change without notice.
  - Customers should place a note on the circuit board fabrication drawing not to alter the center solder mask defined pad.
  - Publication IPC-7351 is recommended for alternate designs.
  - Laser cutting apertures with trapezoidal walls and also rounding corners will offer better paste release. Customers should contact their board assembly site for stencil design recommendations. Example stencil design based on a 50% volumetric metal load solder paste. Refer to IPC-7525 for other stencil recommendations.

## IMPORTANT NOTICE AND DISCLAIMER

TI PROVIDES TECHNICAL AND RELIABILITY DATA (INCLUDING DATASHEETS), DESIGN RESOURCES (INCLUDING REFERENCE DESIGNS), APPLICATION OR OTHER DESIGN ADVICE, WEB TOOLS, SAFETY INFORMATION, AND OTHER RESOURCES "AS IS" AND WITH ALL FAULTS, AND DISCLAIMS ALL WARRANTIES, EXPRESS AND IMPLIED, INCLUDING WITHOUT LIMITATION ANY IMPLIED WARRANTIES OF MERCHANTABILITY, FITNESS FOR A PARTICULAR PURPOSE OR NON-INFRINGEMENT OF THIRD PARTY INTELLECTUAL PROPERTY RIGHTS.

These resources are intended for skilled developers designing with TI products. You are solely responsible for (1) selecting the appropriate TI products for your application, (2) designing, validating and testing your application, and (3) ensuring your application meets applicable standards, and any other safety, security, or other requirements. These resources are subject to change without notice. TI grants you permission to use these resources only for development of an application that uses the TI products described in the resource. Other reproduction and display of these resources is prohibited. No license is granted to any other TI intellectual property right or to any third party intellectual property right. TI disclaims responsibility for, and you will fully indemnify TI and its representatives against, any claims, damages, costs, losses, and liabilities arising out of your use of these resources.

TI's products are provided subject to TI's Terms of Sale ([www.ti.com/legal/termsofsale.html](http://www.ti.com/legal/termsofsale.html)) or other applicable terms available either on [ti.com](http://ti.com) or provided in conjunction with such TI products. TI's provision of these resources does not expand or otherwise alter TI's applicable warranties or warranty disclaimers for TI products.

Mailing Address: Texas Instruments, Post Office Box 655303, Dallas, Texas 75265  
Copyright © 2019, Texas Instruments Incorporated

## Looking for pricing, stock, or lifecycle information?

Click below to explore more details on WIN SOURCE:

 [View SN74AHCT1G08DCKT on WIN SOURCE](#)

 [Texas Instruments](#) Information

## Optimize Your Supply Chain with WIN SOURCE Solutions

-  Global Sourcing Solution
-  Obsolete Management
-  Cost Control Management
-  Shortage Management
-  Alternative Solution
-  Excess Inventory Management