



**THE DATASHEET OF
LTC3350EUHF#PBF**



FEATURES

- High Efficiency Synchronous Step-Down CC/CV Charging of One to Four Series Supercapacitors
- Step-Up Mode in Backup Provides Greater Utilization of Stored Energy in Supercapacitors
- 14-Bit ADC for Monitoring System Voltages/Currents, Capacitance and ESR
- Active Overvoltage Protection Shunts
- Internal Active Balancers—No Balance Resistors
- V_{IN} : 4.5V to 35V, $V_{CAP(n)}$: Up to 5V per Capacitor, Charge/Backup Current: 10+A
- Programmable Input Current Limit Prioritizes System Load Over Capacitor Charge Current
- Dual Ideal Diode PowerPath™ Controller
- All N-FET Charger Controller and PowerPath Controller
- Compact 38-Lead 5mm × 7mm QFN Package

APPLICATIONS

- High Current 12V Ride-Through UPS
- Servers/Mass Storage/High Availability Systems

DESCRIPTION

The **LTC®3350** is a backup power controller that can charge and monitor a series stack of one to four supercapacitors. The LTC3350's synchronous step-down controller drives N-channel MOSFETs for constant current/constant voltage charging with programmable input current limit. In addition, the step-down converter can run in reverse as a step-up converter to deliver power from the supercapacitor stack to the backup supply rail. Internal balancers eliminate the need for external balance resistors and each capacitor has a shunt regulator for overvoltage protection.

The LTC3350 monitors system voltages, currents, stack capacitance and stack ESR which can all be read over the I²C/SMBus. The dual ideal diode controller uses N-channel MOSFETs for low loss power paths from the input and supercapacitors to the backup system supply. The LTC3350 is available in a low profile 38-lead 5mm × 7mm × 0.75mm QFN surface mount package.

LT, LT, LTC, LTM, Linear Technology and the Linear logo are registered trademarks and PowerPath are trademarks of Linear Technology Corporation. All other trademarks are the property of their respective owners. Patents pending.

TYPICAL APPLICATION

High Current Supercapacitor Charger and Backup Supply

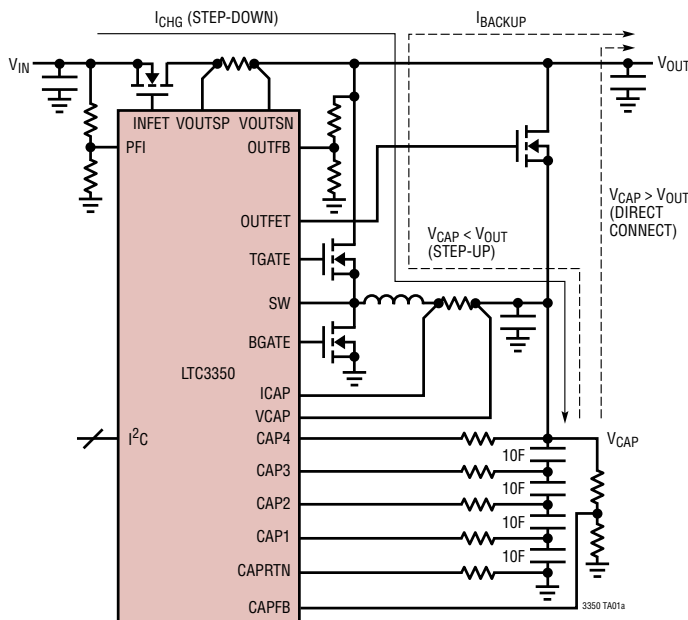

Backup Operation

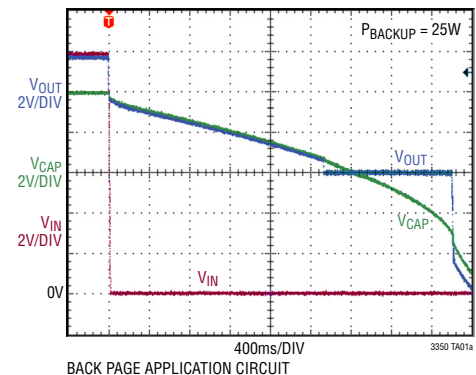

TABLE OF CONTENTS

Features	1	Applications Information	21
Applications	1	Digital Configuration	21
Typical Application	1	Capacitor Configuration	21
Description	1	Capacitor Shunt Regulator Programming	21
Absolute Maximum Ratings	3	Setting Input and Charge Currents	21
Order Information	3	Low Current Charging and High Current Backup ...	22
Pin Configuration	3	Setting V_{CAP} Voltage	22
Electrical Characteristics	4	Power-Fail Comparator Input Voltage Threshold ...	22
Typical Performance Characteristics	7	Setting V_{OUT} Voltage in Backup Mode	23
Pin Functions	10	Compensation	24
Block Diagram	13	Minimum V_{CAP} Voltage in Backup Mode	24
Timing Diagram	14	Optimizing Supercapacitor Energy Storage Capacity ..	25
Operation	14	Capacitor Selection Procedure	26
Introduction	14	Inductor Selection	26
Bidirectional Switching Controller—Step-Down		C_{OUT} and C_{CAP} Capacitance	27
Mode	14	Power MOSFET Selection	28
Bidirectional Switching Controller—Step-Up Mode	15	Schottky Diode Selection	28
Ideal Diodes	16	Top MOSFET Driver Supply (C_B , D_B)	29
Gate Drive Supply (DRV_{CC})	17	$INTV_{CC}/DRV_{CC}$ and IC Power Dissipation	29
Undervoltage Lockout (UVLO)	17	Minimum On-Time Considerations	30
RT Oscillator and Switching Frequency	17	Ideal Diode MOSFET Selection	30
Input Overvoltage Protection	17	PCB Layout Considerations	30
V_{CAP} DAC	17	Register Map	32
Power-Fail (PF) Comparator	17	Register Descriptions	33
Charge Status Indication	17	Typical Applications	39
Capacitor Voltage Balancer	17	Package Description	44
Capacitor Shunt Regulators	18	Revision History	45
I ² C/SMBus and SMBALERT	18	Typical Application	46
Analog-to-Digital Converter	18	Related Parts	46
Capacitance and ESR Measurement	18		
Monitor Status Register	19		
Charge Status Register	20		
Limit Checking and Alarms	20		
Die Temperature Sensor	20		
General Purpose Input	20		

ABSOLUTE MAXIMUM RATINGS

(Note 1)

V_{IN} , VOUTSP, VOUTSN.....	-0.3V to 40V
VCAP.....	-0.3V to 22V
CAP4-CAP3, CAP3-CAP2, CAP2-CAP1, CAP1-CAPRTN	-0.3V to 5.5V
DRV _{CC} , OUTFB, CAPFB, SMBALERT, CAPGD, PFO, GPI, SDA, SCL	-0.3V to 5.5V
BST	-0.3V to 45.5V
PFI	-0.3V to 20V
CAP_SLCT0, CAP_SLCT1	-0.3 to 3V
BST to SW	-0.3V to 5.5V
VOUTSP to VOUTSN, ICAP to VCAP	-0.3V to 0.3V
I _{INTVCC}	100mA
I _{CAP(1,2,3,4)} , I _{CAPRTN}	600mA
I _{CAPGD} , I _{PFO} , I _{SMBALERT}	10mA
Operating Junction Temperature Range (Notes 2, 3).....	-40°C to 125°C
Storage Temperature Range	-65°C to 150°C

PIN CONFIGURATION

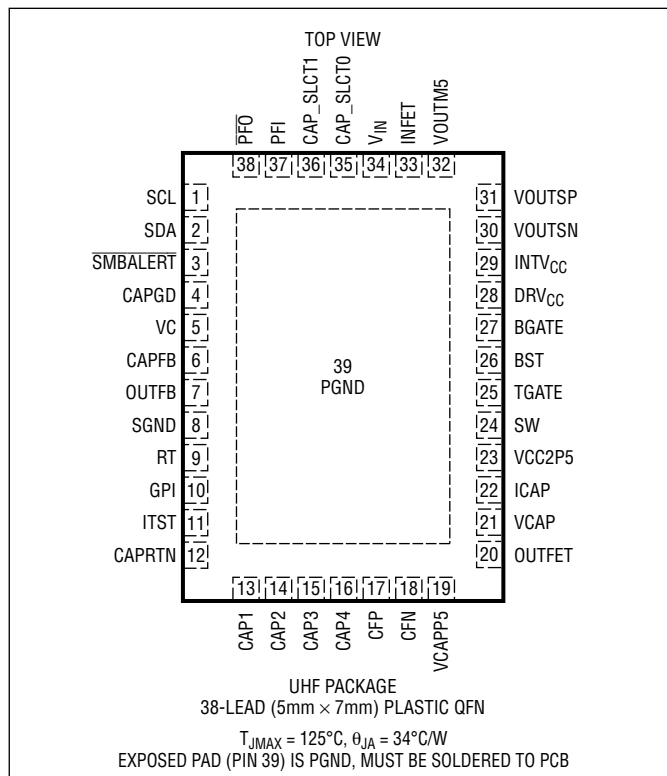

ORDER INFORMATION

LEAD FREE FINISH	TAPE AND REEL	PART MARKING*	PACKAGE DESCRIPTION	TEMPERATURE RANGE
LTC3350EUHF#PBF	LTC3350EUHF#TRPBF	3350	38-Lead (5mm × 7mm) Plastic QFN	-40°C to 125°C
LTC3350IUHF#PBF	LTC3350IUHF#TRPBF	3350	38-Lead (5mm × 7mm) Plastic QFN	-40°C to 125°C

Consult LTC Marketing for parts specified with wider operating temperature ranges. *The temperature grade is identified by a label on the shipping container. Consult LTC Marketing for information on nonstandard lead based finish parts.

For more information on lead free part marking, go to: <http://www.linear.com/leadfree/>

For more information on tape and reel specifications, go to: <http://www.linear.com/tapeandreel/>

ELECTRICAL CHARACTERISTICS The ● denotes the specifications which apply over the specified operating junction temperature range, otherwise specifications are at $T_A = 25^\circ\text{C}$ (Note 2). $V_{IN} = V_{OUT} = 12\text{V}$, $V_{DRVCC} = V_{INTVCC}$ unless otherwise noted.

SYMBOL	PARAMETER	CONDITIONS	MIN	TYP	MAX	UNITS
Switching Regulator						
V_{IN}	Input Supply Voltage		● 4.5		35	V
I_Q	Input Quiescent Current (Note 4)			4		mA
$V_{CAPFBHI}$	Maximum Regulated V_{CAP} Feedback Voltage	V_{CAPDAC} Full Scale (1111b)	● 1.188 1.176	1.200 1.200	1.212 1.224	V V
$V_{CAPFBLO}$	Minimum Regulated V_{CAP} Feedback Voltage	V_{CAPDAC} Zero Scale (0000b)		0.628 0.638	0.647	V
I_{CAPFB}	CAPFB Input Leakage Current	$V_{CAPFB} = 1.2\text{V}$	● -50		50	nA
V_{OUTFB}	Regulated V_{OUT} Feedback Voltage		● 1.188 1.176	1.200 1.200	1.212 1.224	V V
$V_{OUTFB(TH)}$	OUTFET Turn-Off Threshold	Falling Threshold		1.27 1.3	1.33	V
I_{OUTFB}	OUTFB Input Leakage Current	$V_{OUTFB} = 1.2\text{V}$	● -50		50	nA
V_{OUTBST}	V_{OUT} Voltage in Step-Up Mode	$V_{IN} = 0\text{V}$	● 4.5		35	V
V_{UVLO}	INTV _{CC} Undervoltage Lockout	Rising Threshold Falling Threshold	● 3.85	4.3 4	4.45	V V
$V_{DRVUVLO}$	DRV _{CC} Undervoltage Lockout	Rising Threshold Falling Threshold	● 3.75	4.2 3.9	4.35	V V
V_{DUVLO}	$V_{IN} - V_{CAP}$ Differential Undervoltage Lockout	Rising Threshold Falling Threshold	● 145 ● 55	185 90	225 125	mV mV
V_{OVLO}	V_{IN} Overvoltage Lockout	Rising Threshold Falling Threshold	● 37.7 ● 36.3	38.6 37.2	39.5 38.1	V V
V_{VCAPP5}	Charge Pump Output Voltage	Relative to V_{CAP} , $0\text{V} \leq V_{CAP} \leq 20\text{V}$		5		V
Input Current Sense Amplifier						
V_{SNSI}	Regulated Input Current Sense Voltage ($V_{OUTSP} - V_{OUTSN}$)		● 31.36 31.04	32.00 32.00	32.64 32.96	mV mV
Charge Current Sense Amplifier						
V_{SNSC}	Regulated Charge Current Sense Voltage ($I_{CAP} - V_{CAP}$)	$V_{CAP} = 10\text{V}$	● 31.36 31.04	32.00 32.00	32.64 32.96	mV mV
V_{CMC}	Common Mode Range (I_{CAP} , V_{CAP})			0	20	V
V_{PEAK}	Peak Inductor Current Sense Voltage		● 51	58	65	mV
V_{REV}	Reverse Inductor Current Sense Voltage	Step-Down Mode	● 3.867	7	10	mV
I_{ICAP}	ICAP Pin Current	Step-Down Mode, $V_{SNSC} = 32\text{mV}$ Step-Up Mode, $V_{SNSC} = 32\text{mV}$		30 135		μA μA
Error Amplifier						
g_{MV}	V_{CAP} Voltage Loop Transconductance			1		mmho
g_{MC}	Charge Current Loop Transconductance			64		μmho
g_{MI}	Input Current Loop Transconductance			64		μmho
g_{MO}	V_{OUT} Voltage Loop Transconductance			400		μmho
Oscillator						
f_{SW}	Switching Frequency	$R_T = 107\text{k}$	● 495 490	500 500	505 510	kHz kHz
	Maximum Programmable Frequency	$R_T = 53.6\text{k}$		1		MHz
	Minimum Programmable Frequency	$R_T = 267\text{k}$		200		kHz

ELECTRICAL CHARACTERISTICS The ● denotes the specifications which apply over the specified operating junction temperature range, otherwise specifications are at $T_A = 25^\circ\text{C}$ (Note 2). $V_{IN} = V_{OUT} = 12\text{V}$, $V_{DRVCC} = V_{INTVCC}$ unless otherwise noted.

SYMBOL	PARAMETER	CONDITIONS	MIN	TYP	MAX	UNITS	
DC _{MAX}	Maximum Duty Cycle	Step-Down Mode	97	98	99.5	%	
		Step-Up Mode	87	93		%	
Gate Drivers							
R _{UP-TG}	TGATE Pull-Up On-Resistance			2		Ω	
R _{DOWN-TG}	TGATE Pull-Down On-Resistance			0.6		Ω	
R _{UP-BG}	BGATE Pull-Up On-Resistance			2		Ω	
R _{DOWN-BG}	BGATE Pull-Down On-Resistance			0.6		Ω	
t _{r-TG}	TGATE 10% to 90% Rise Time	C _{LOAD} = 3.3nF		18	25	ns	
t _{f-TG}	TGATE 10% to 90% Fall Time	C _{LOAD} = 3.3nF		8	15	ns	
t _{r-BG}	BGATE 10% to 90% Rise Time	C _{LOAD} = 3.3nF		18	25	ns	
t _{f-BG}	BGATE 10% to 90% Fall Time	C _{LOAD} = 3.3nF		8	15	ns	
t _{NO}	Non-Overlap Time			50		ns	
t _{ON(MIN)}				85		ns	
INTV_{CC} Linear Regulator							
V _{INTVCC}	Internal V _{CC} Voltage	5.2V ≤ V _{IN} ≤ 35V		5		V	
ΔV _{INTVCC}	Load Regulation	I _{INTVCC} = 50mA		-1.5	-2.5	%	
PowerPath/Ideal Diodes							
V _{FTO}	Forward Turn-On Voltage			65		mV	
V _{FR}	Forward Regulation			30		mV	
V _{RTO}	Reverse Turn Off			-30		mV	
t _{IF(ON)}	INFET Rise Time	INFET – V _{IN} > 3V, C _{INFET} = 3.3nF		560		μs	
t _{IF(OFF)}	INFET Fall Time	INFET – V _{IN} < 1V, C _{INFET} = 3.3nF		1.5		μs	
t _{OF(ON)}	OUTFET Rise Time	OUTFET – V _{CAP} > 3V, C _{OUTFET} = 3.3nF		0.13		μs	
t _{OF(OFF)}	OUTFET Fall Time	OUTFET – V _{CAP} < 1V, C _{OUTFET} = 3.3nF		0.26		μs	
Power-Fail Comparator							
V _{PFI(TH)}	PFI Input Threshold (Falling Edge)		●	1.147	1.17	1.193	V
V _{PFI(HYS)}	PFI Hysteresis			30		mV	
I _{PFI}	PFI Input Leakage Current	V _{PFI} = 0.5V	●	-50	50	nA	
V _{PFO}	PFO Output Low Voltage	I _{SINK} = 5mA		200		mV	
I _{PFO}	PFO High-Z Leakage Current	V _{PFO} = 5V	●		1	μA	
	PFI Falling to PFO Low Delay			85		ns	
	PFI Rising to PFO High Delay			0.4		μs	
CAPGD							
V _{CAPFB(TH)}	CAPGD Rising Threshold as % of Regulated V _{CAP} Feedback Voltage	V _{capfb_dac} = Full Scale (1111b)	●	90	92	94	%
V _{CAPFB(HYS)}	CAPGD Hysteresis at CAPFB as a % of Regulated V _{CAP} Feedback Voltage	V _{capfb_dac} = Full Scale (1111b)		1.25		%	
V _{CAPGD}	CAPGD Output Low Voltage	I _{SINK} = 5mA		200		mV	
I _{CAPGD}	CAPGD High-Z Leakage Current	V _{CAPGD} = 5V	●		1	μA	

ELECTRICAL CHARACTERISTICS The ● denotes the specifications which apply over the specified operating junction temperature range, otherwise specifications are at $T_A = 25^\circ\text{C}$ (Note 2). $V_{IN} = V_{OUT} = 12\text{V}$, $V_{DRVCC} = V_{INTVCC}$ unless otherwise noted.

SYMBOL	PARAMETER	CONDITIONS	MIN	TYP	MAX	UNITS	
Analog-to-Digital Converter							
V_{RES}	Measurement Resolution			16		Bits	
V_{GPI}	General Purpose Input Voltage Range	Unbuffered Buffered	0 0		5 3.5	V V	
I_{GPI}	General Purpose Input Pin Leakage Current	Buffered Input			1	μA	
R_{GPI}	GPI Pin Resistance	Buffer Disabled		2.5		$\text{M}\Omega$	
Measurement System Error							
V_{ERR}	Measurement Error (Note 5)	$V_{IN} = 0\text{V}$ $V_{IN} = 30\text{V}$			100 1.5	mV %	
		$V_{OUTSP} = 5\text{V}$ $V_{OUTSP} = 30\text{V}$			100 1.5	mV %	
		$V_{CAP} = 0\text{V}$ $V_{CAP} = 10\text{V}$			100 1.5	mV %	
		$V_{GPI} = 0\text{V}$, Unbuffered $V_{GPI} = 3.5\text{V}$, Unbuffered			2 1	mV %	
		$V_{CAP1} = 0\text{V}$ $V_{CAP1} = 2\text{V}$			2 1	mV %	
		$V_{CAP2} = 0\text{V}$ $V_{CAP2} = 2\text{V}$			2 1	mV %	
		$V_{CAP3} = 0\text{V}$ $V_{CAP3} = 2\text{V}$			2 1	mV %	
		$V_{CAP4} = 0\text{V}$ $V_{CAP4} = 2\text{V}$			2 1	mV %	
		$V_{SNSI} = 0\text{mV}$ $V_{SNSI} = 32\text{mV}$			200 2	μV %	
		$V_{SNSC} = 0\text{mV}$ $V_{SNSC} = 32\text{mV}$			200 2	μV %	
CAP1 to CAP4							
R_{SHNT}	Shunt Resistance			0.5		Ω	
DV_{CAPMAX}	Maximum Capacitor Voltage with Shunts Enabled	2 or More Capacitors in Stack			3.6	V	
Programming Pins							
V_{ITST}	ITST Voltage	$R_{TST} = 121\Omega$		1.185	1.197	1.209	V
I²C/SMBus – SDA, SCL, SMBALERT							
$I_{IL,SDA,SCL}$	Input Leakage Low			-1		1	μA
$I_{IH,SDA,SCL}$	Input Leakage High			-1		1	μA
V_{IH}	Input High Threshold			1.5			V
V_{IL}	Input Low Threshold					0.8	V
f_{SCL}	SCL Clock Frequency					400	kHz
t_{LOW}	Low Period of SCL Clock			1.3			μs
t_{HIGH}	High Period of SCL Clock			0.6			μs
t_{BUF}	Bus Free Time Between Start and Stop Conditions			1.3			μs
$t_{HD,STA}$	Hold Time, After (Repeated) Start Condition			0.6			μs
$t_{SU,STA}$	Setup Time After a Repeated Start Condition			0.6			μs

ELECTRICAL CHARACTERISTICS The ● denotes the specifications which apply over the specified operating junction temperature range, otherwise specifications are at $T_A = 25^\circ\text{C}$ (Note 2). $V_{IN} = V_{OUT} = 12\text{V}$, $V_{DRVCC} = V_{INTVCC}$ unless otherwise noted.

SYMBOL	PARAMETER	CONDITIONS	MIN	TYP	MAX	UNITS
$t_{SU,STO}$	Stop Condition Set-Up Time		0.6			μs
$t_{HD,DATO}$	Output Data Hold Time		0		900	ns
$t_{HD,DATI}$	Input Data Hold Time		0			ns
$t_{SU,DAT}$	Data Set-Up Time		100			ns
t_{SP}	Input Spike Suppression Pulse Width				50	ns
$V_{SMBALERT}$	SMBALERT Output Low Voltage	$I_{SINK} = 1\text{mA}$		200		mV
$I_{SMBALERT}$	SMBALERT High-Z Leakage Current	$V_{SMBALERT} = 5\text{V}$	●		1	μA

Note 1: Stresses beyond those listed under Absolute Maximum Ratings may cause permanent damage to the device. Exposure to any Absolute Maximum Rating condition for extended periods may affect device reliability and lifetime.

Note 2: The LTC3350 is tested under pulsed load conditions such that $T_J \approx T_A$. The LTC3350E is guaranteed to meet specifications from 0°C to 125°C junction temperature. Specifications over the -40°C to 125°C operating junction temperature range are assured by design, characterization and correlation with statistical process controls. The LTC3350I is guaranteed over the -40°C to 125°C operating junction temperature range. Note that the maximum ambient temperature consistent with these specifications is determined by specific operating conditions in conjunction with board layout, the rated package thermal impedance and other environmental factors. The junction temperature (T_J , in $^\circ\text{C}$) is calculated from the ambient temperature (T_A , in $^\circ\text{C}$) and power dissipation (P_D , in Watts) according to the formula:

$$T_J = T_A + (P_D \cdot \theta_{JA})$$

where $\theta_{JA} = 34^\circ\text{C/W}$ for the UHF package.

Note 3: The LTC3350 includes overtemperature protection that is intended to protect the device during momentary overload conditions. Junction temperature will exceed 125°C when overtemperature protection is active. Continuous operation above the specified maximum operating junction temperature may impair device reliability.

Note 4: Dynamic supply current is higher due to the gate charge being delivered at the switching frequency. See the Applications Information section.

Note 5: Measurement error is the magnitude of the difference between the actual measured value and the ideal value. V_{SNSI} is the voltage between V_{OUTSP} and V_{OUTSN} , representing input current. V_{SNSC} is the voltage between I_{CAP} and V_{CAP} , representing charge current. Error for V_{SNSI} and V_{SNSC} is expressed in μV , a conversion to an equivalent current may be made by dividing by the sense resistors, R_{SNSI} and R_{SNSC} , respectively.

TYPICAL PERFORMANCE CHARACTERISTICS

$T_A = 25^\circ\text{C}$, Application Circuit 4 unless otherwise noted.

Supercapacitor Backup Operation

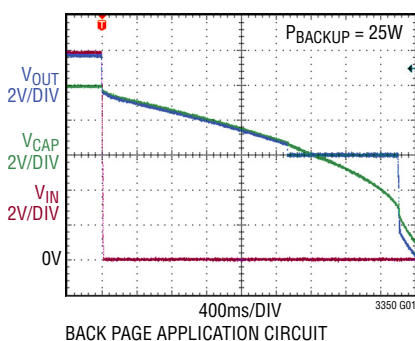

HV Electrolytic Backup Operation

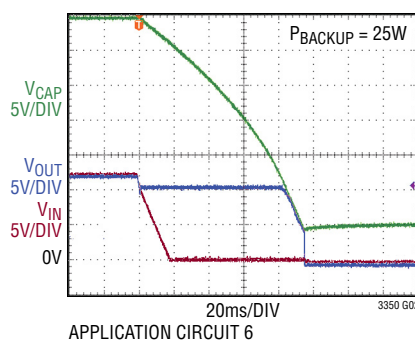

Shunt Operation Using VCAP2

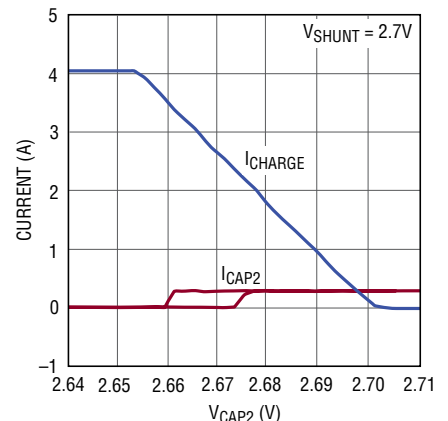

3350 G03

3350fc

TYPICAL PERFORMANCE CHARACTERISTICS

$T_A = 25^\circ\text{C}$, Application Circuit 4 unless otherwise noted.

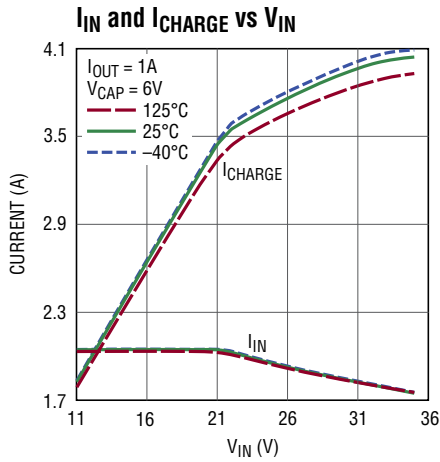

3350 G04

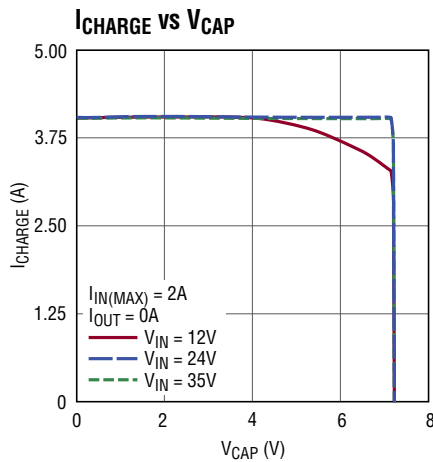

3350 G05

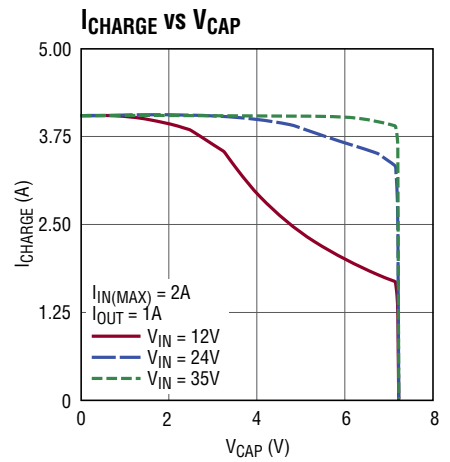

3350 G06

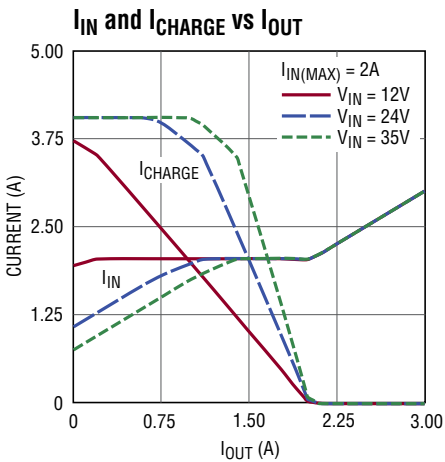

3350 G07

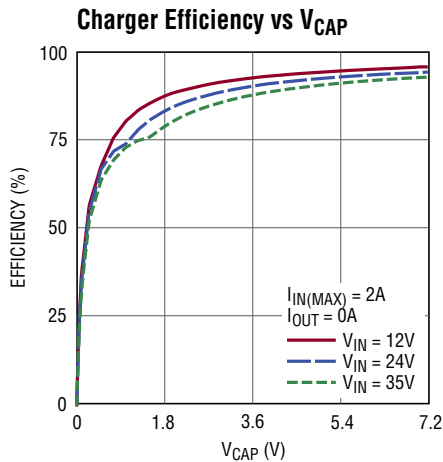

3350 G08

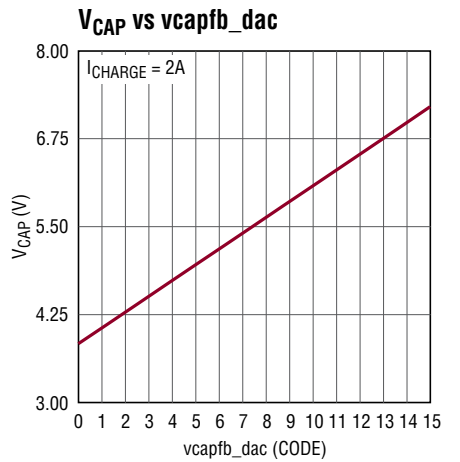

3350 G09

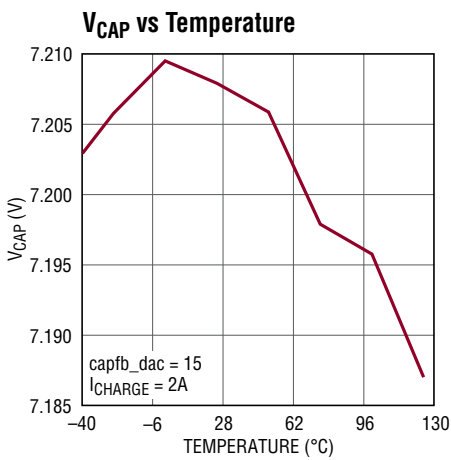

3350 G10

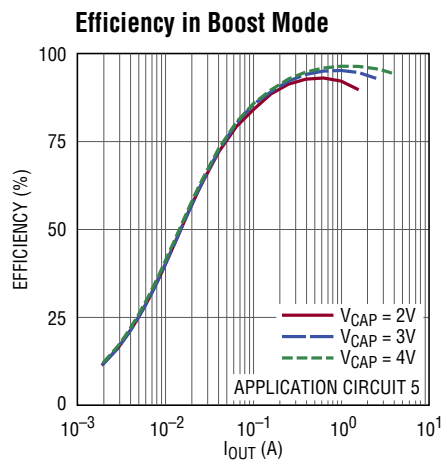

3350 G11

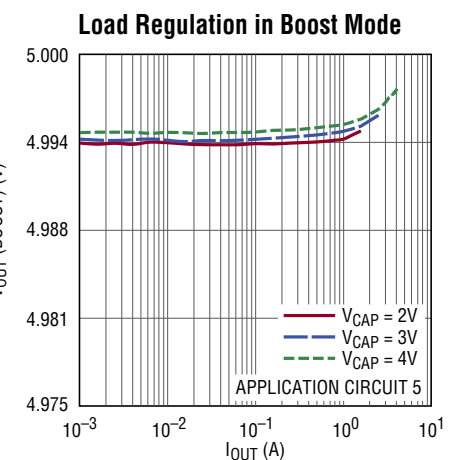

3350 G12

TYPICAL PERFORMANCE CHARACTERISTICS

$T_A = 25^\circ\text{C}$, Application Circuit 4 unless otherwise noted.

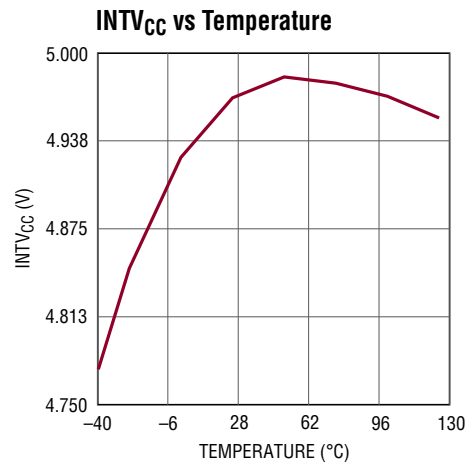
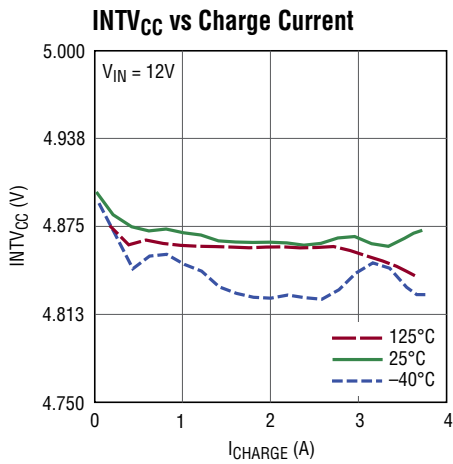
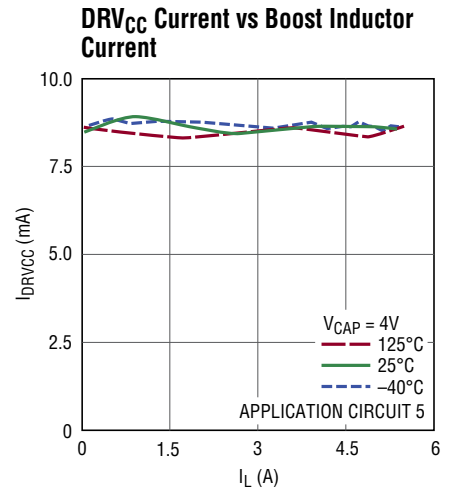
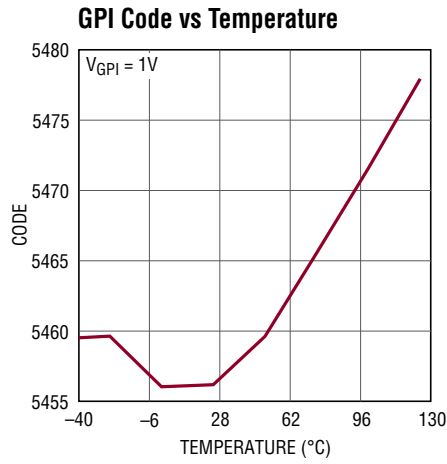
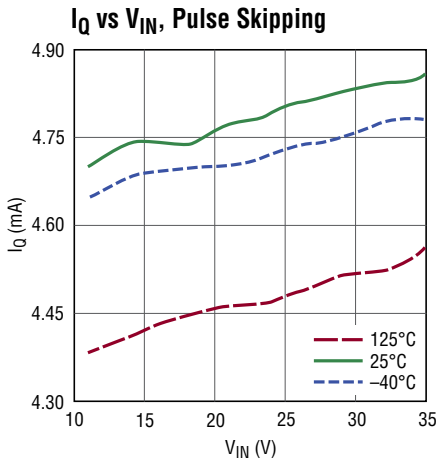

PIN FUNCTIONS

SCL (Pin 1): Clock Pin for the I²C/SMBus Serial Port.

SDA (Pin 2): Bidirectional Data Pin for the I²C/SMBus Serial Port.

SMBALERT (Pin 3): Interrupt Output. This open-drain output is pulled low when an alarm threshold is exceeded, and will remain low until the acknowledgement of the part's response to an SMBus ARA.

CAPGD (Pin 4): Capacitor Power Good. This open-drain output is pulled low when CAPFB is below 92% of its regulation point.

VC (PIN 5): Control Voltage Pin. This is the compensation node for the charge current, input current, supercapacitor stack voltage and output voltage control loops. An RC network is connected between VC and SGND. Nominal voltage range for this pin is 1V to 3V.

CAPFB (Pin 6): Capacitor Stack Feedback Pin. This pin closes the feedback loop for constant voltage regulation. An external resistor divider between VCAP and SGND with the center tap connected to CAPFB programs the final supercapacitor stack voltage. This pin is nominally equal to the output of the V_{CAP} DAC when the synchronous controller is in constant voltage mode while charging.

OUTFB (Pin 7): Step-Up Mode Feedback Pin. This pin closes the feedback loop for voltage regulation of V_{OUT} during input power failure using the synchronous controller in step-up mode. An external resistor divider between V_{OUT} and SGND with the center tap connected to OUTFB programs the minimum backup supply rail voltage when input power is unavailable. This pin is nominally 1.2V when in backup and the synchronous controller is not in current limit. To disable step-up mode tie OUTFB to INTV_{CC}.

SGND (Pin 8): Signal Ground. All small-signal and compensation components should be connected to this pin, which in turn connects to PGND at one point. This pin should also Kelvin to the bottom plate of the capacitor stack.

RT (Pin 9): Timing Resistor. The switching frequency of the synchronous controller is set by placing a resistor, R_T, from this pin to SGND. This resistor is always required. If not present the synchronous controller will not start.

GPI (Pin 10): General Purpose Input. The voltage on this pin is digitized directly by the ADC. For high impedance inputs an internal buffer can be selected and used to drive the ADC. The GPI pin can be connected to a negative temperature coefficient (NTC) thermistor to monitor the temperature of the supercapacitor stack. A low drift bias resistor is required from INTV_{CC} to GPI and a thermistor is required from GPI to ground. Connect GPI to SGND if not used. The digitized voltage on this pin can be read in the meas_gpi register.

ITST (Pin 11): Programming Pin for Capacitance Test Current. This current is used to partially discharge the capacitor stack at a precise rate for capacitance measurement. This pin servos to 1.2V during a capacitor measurement. A resistor, R_{TST}, from this pin to SGND programs the test current. R_{TST} must be at least 121Ω.

CAPRTN (Pin 12): Capacitor Stack Shunt Return Pin. This pin is connected to the grounded bottom plate of the first super capacitor in the stack through a shunt resistor.

CAP1 (Pin 13): First Supercapacitor Pin. The top plate of the first supercapacitor and the bottom plate of the second supercapacitor are connected to this pin through a shunt resistor. CAP1 and CAPRTN are used to measure the voltage across the first super capacitor and to shunt current around the capacitor to provide balancing and prevent overvoltage. The voltage between this pin and CAPRTN is digitized and can be read in the meas_vcap1 register.

CAP2 (Pin 14): Second Supercapacitor Pin. The top plate of the second supercapacitor and the bottom plate of the third supercapacitor are connected to this pin through a shunt resistor. CAP2 and CAP1 are used to measure the voltage across the second supercapacitor and to shunt

PIN FUNCTIONS

current around the capacitor to provide balancing and prevent overvoltage. If not used this pin should be shorted to CAP1. The voltage between this pin and CAP1 is digitized and can be read in the meas_vcap2 register.

CAP3 (Pin 15): Third Supercapacitor Pin. The top plate of the third supercapacitor and the bottom plate of the fourth supercapacitor are connected to this pin through a shunt resistor. CAP3 and CAP2 are used to measure the voltage across the third supercapacitor and to shunt current around the capacitor to provide balancing and prevent overvoltage. If not used this pin should be shorted to CAP2. The voltage between this pin and CAP2 is digitized and can be read in the meas_vcap3 register.

CAP4 (Pin 16): Fourth Supercapacitor Pin. The top plate of the fourth supercapacitor is connected to this pin through a shunt resistor. CAP4 and CAP3 are used to measure the voltage on the capacitor and to shunt current around the supercapacitor to provide balancing and prevent overvoltage. If not used this pin should be shorted to CAP3. The voltage between this pin and CAP3 is digitized and can be read in the meas_vcap4 register. The capacitance test current set by the ITST pin is pulled from this pin.

CFP (Pin 17): VCAPP5 Charge Pump Flying Capacitor Positive Terminal. Place a 0.1 μ F between CFP and CFN.

CFN (Pin 18): VCAPP5 Charge Pump Flying Capacitor Negative Terminal. Place a 0.1 μ F between CFP and CFN.

VCAPP5 (Pin 19): Charge Pump Output. The internal charge pump drives this pin to VCAP + INTV_{CC} which is used as the high side rail for the OUTFET gate drive and charge current sense amplifier. Connect a 0.1 μ F capacitor from VCAPP5 to VCAP.

OUTFET (Pin 20): Output Ideal Diode Gate Drive Output. This pin controls the gate of an external N-channel MOSFET used as an ideal diode between V_{OUT} and V_{CAP}. The gate drive receives power from the internal charge pump output VCAPP5. The source of the N-channel MOSFET should be connected to VCAP and the drain should be connected to VOUTSN. If the output ideal diode MOSFET is not used, OUTFET should be left floating.

VCAP (Pin 21): Supercapacitor Stack Voltage and Charge Current Sense Amplifier Negative Input. Connect this pin to the top of the supercapacitor stack. The voltage at this pin is digitized and can be read in the meas_vcap register.

ICAP (Pin 22): Charge Current Sense Amplifier Positive Input. The ICAP and VCAP pins measure the voltage across the sense resistor, R_{SN_{SC}}, to provide instantaneous current signals for the control loops and ESR measurement system. The maximum charge current is 32mV/R_{SN_{SC}}.

VCC2P5 (Pin 23): Internal 2.5V Regulator Output. This regulator provides power to the internal logic circuitry. Decouple this pin to ground with a minimum 1 μ F low ESR tantalum or ceramic capacitor.

SW (Pin 24): Switch Node Connection to the Inductor. The negative terminal of the boot-strap capacitor, C_B, is connected to this pin. The voltage on this pin is also used as the source reference for the top side N-channel MOSFET gate drive. In step-down mode, the voltage swing on this pin is from a diode (external) forward voltage below ground to V_{OUT}. In step-up mode the voltage swing is from ground to a diode forward voltage above V_{OUT}.

TGATE (Pin 25): Top Gate Driver Output. This pin is the output of a floating gate driver for the top external N-channel MOSFET. The voltage swing at this pin is ground to V_{OUT} + DRV_{CC}.

BST (Pin 26): TGATE Driver Supply Input. The positive terminal of the boot-strap capacitor, C_B, is connected to this pin. This pin swings from a diode voltage drop below DRV_{CC} up to V_{OUT} + DRV_{CC}.

BGATE (Pin 27): Bottom Gate Driver Output. This pin drives the bottom external N-channel MOSFET between PGND and DRV_{CC}.

DRV_{CC} (Pin 28): Power Rail for Bottom Gate Driver. Connect to INTV_{CC} or to an external supply. Decouple this pin to ground with a minimum 2.2 μ F low ESR tantalum or ceramic capacitor. Do not exceed 5.5V on this pin.

PIN FUNCTIONS

INTV_{CC} (Pin 29): Internal 5V Regulator Output. The control circuits and gate drivers (when connected to DRV_{CC}) are powered from this supply. If not connected to DRV_{CC}, decouple this pin to ground with a minimum 1 μ F low ESR tantalum or ceramic capacitor.

VOUTSN (Pin 30): Input Current Limiting Amplifier Negative Input. A sense resistor, R_{SNSI}, between VOUTSP and VOUTSN sets the input current limit. The maximum input current is 32mV/R_{SNSI}. An RC network across the sense resistor can be used to modify loop compensation. To disable input current limit, connect this pin to VOUTSP.

VOUTSP (Pin 31): Backup System Supply Voltage and Input Current Limiting Amplifier Positive Input. The voltage across the VOUTSP and VOUTSN pins are used to regulate input current. This pin also serves as the power supply for the IC. The voltage at this pin is digitized and can be read in the meas_vout register.

VOUTM5 (Pin 32): V_{OUT} – 5V Regulator. This pin is regulated to 5V below V_{OUT} or to ground if V_{OUT} < 5V. This rail provides power to the input current sense amplifier. Decouple this pin with at least 1 μ F to V_{OUT}.

INFET (Pin 33): Input Ideal Diode Gate Drive Output. This pin controls the gate of an external N-channel MOSFET used as an ideal diode between V_{IN} and V_{OUT}. The gate drive receives power from an internal charge pump. The source of the N-channel MOSFET should be connected to V_{IN} and the drain should be connected to VOUTSP. If the input ideal diode MOSFET is not used, INFET should be left floating.

V_{IN} (Pin 34): External DC Power Source Input. Decouple this pin with at least 0.1 μ F to ground. The voltage at this pin is digitized and can be read in the meas_vin register.

CAP_SLCT0, CAP_SLCT1 (Pins 35, 36): CAP_SLCT0 and CAP_SLCT1 set the number of super-capacitors used. Refer to Table 1 in the Applications Information section.

PFI (Pin 37): Power-Fail Comparator Input. When the voltage at this pin drops below 1.17V, PFO is pulled low and step-up mode is enabled.

PFO (Pin 38): Power-Fail Status Output. This open-drain output is pulled low when a power fault has occurred.

PGND (Exposed Pad Pin 39): Power Ground. The exposed pad must be connected to a continuous ground plane on the second layer of the printed circuit board by several vias directly under the LTC3350 for rated thermal performance. It must be tied to the SGND pin.

BLOCK DIAGRAM

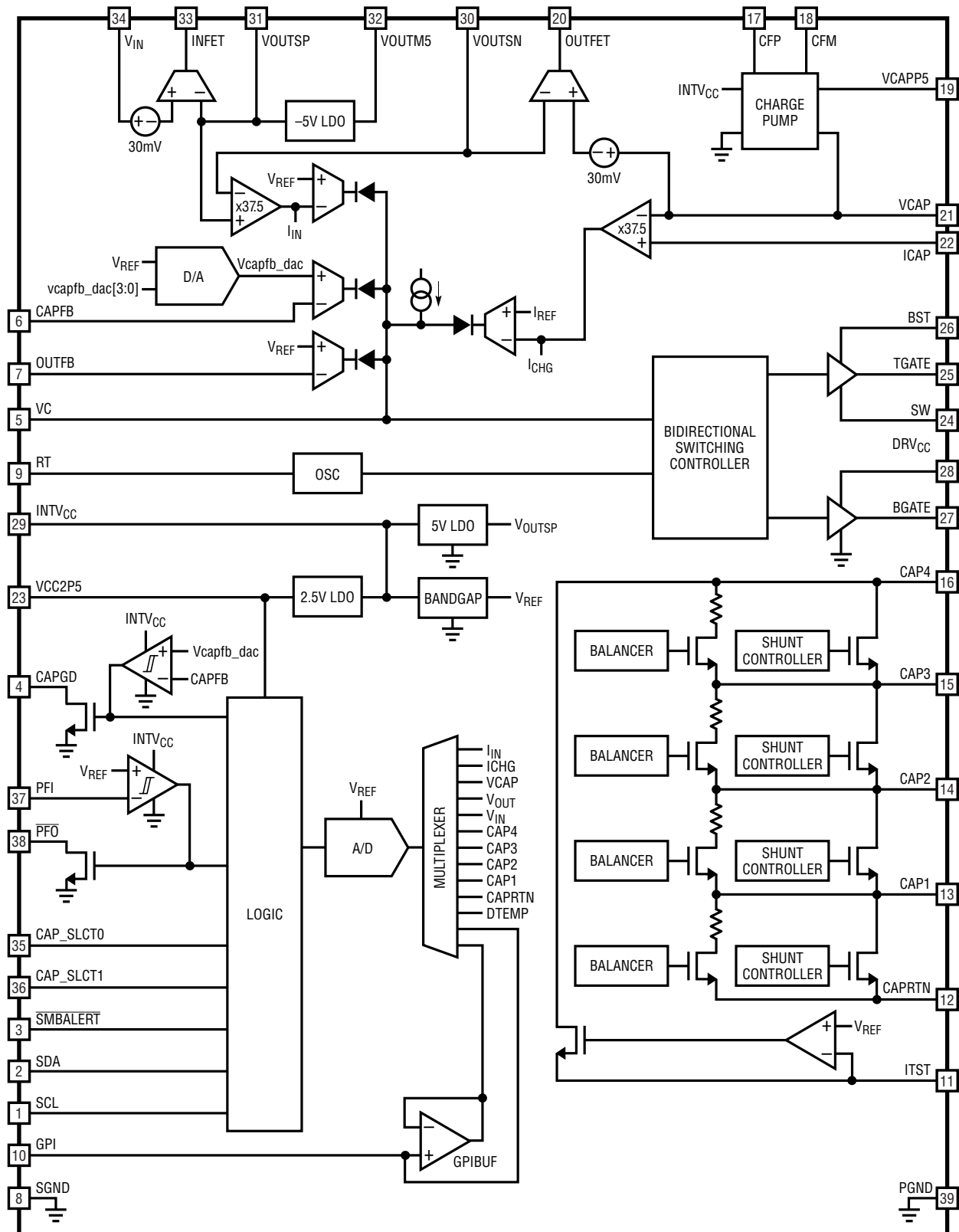

3350 BD

TIMING DIAGRAM

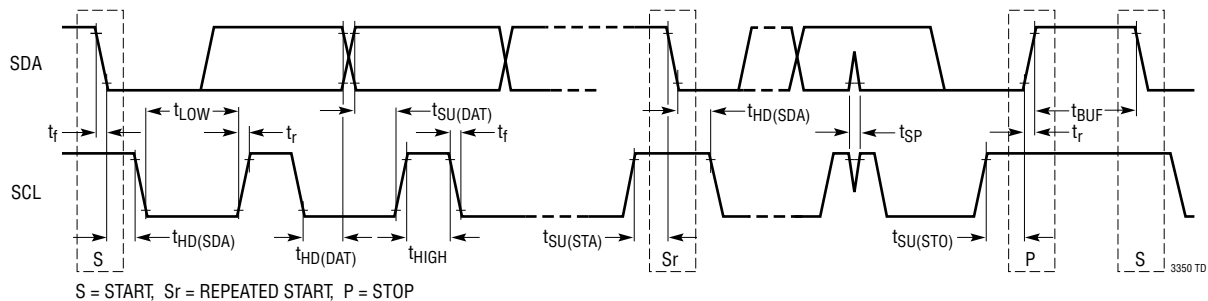
Definition of Timing for F/S Mode Devices on the I²C Bus

OPERATION

Introduction

The LTC3350 is a highly integrated backup power controller and system monitor. It features a bidirectional switching controller, input and output ideal diodes, supercapacitor shunts/balancers, a power-fail comparator, a 14-bit ADC and I²C/SMBus programmability with status reporting.

If V_{IN} is above an externally programmable PFI threshold voltage, the synchronous controller operates in step-down mode and charges a stack of supercapacitors. A programmable input current limit ensures that the supercapacitors will automatically be charged at the highest possible charge current that the input can support. If V_{IN} is below the PFI threshold, then the synchronous controller will run in reverse as a step-up converter to deliver power from the supercapacitor stack to V_{OUT} .

The two ideal diode controllers drive external MOSFETs to provide low loss power paths from V_{IN} and V_{CAP} to V_{OUT} . The ideal diodes work seamlessly with the bidirectional controller to provide power from the supercapacitors to V_{OUT} without backdriving V_{IN} .

The LTC3350 provides balancing and overvoltage protection to a series stack of one to four supercapacitors. The internal capacitor voltage balancers eliminate the need for external balance resistors. Overvoltage protection is provided by shunt regulators that use an internal switch and an external resistor across each supercapacitor.

The LTC3350 monitors system voltages, currents, and die temperature. A general purpose input (GPI) pin is provided to measure an additional system parameter or implement a thermistor measurement. In addition, the LTC3350 can measure the capacitance and resistance of the supercapacitor stack. This provides indication of the health of the supercapacitors and, along with the V_{CAP} voltage measurement, provides information on the total energy stored and the maximum power that can be delivered.

Bidirectional Switching Controller—Step-Down Mode

The bidirectional switching controller is designed to charge a series stack of supercapacitors (Figure 1). Charging proceeds at a constant current until the supercapacitors reach their maximum charge voltage determined by the CAPFB servo voltage and the resistor divider between V_{CAP} and CAPFB. The maximum charge current is determined by the value of the sense resistor, R_{SNSC} , used in series with the inductor. The charge current loop servos the voltage across the sense resistor to 32mV. When charging begins, an internal soft-start ramp will increase the charge current from zero to full current in 2ms. The V_{CAP} voltage and charge current can be read from the meas_vcap and meas_ichrg registers, respectively.

OPERATION

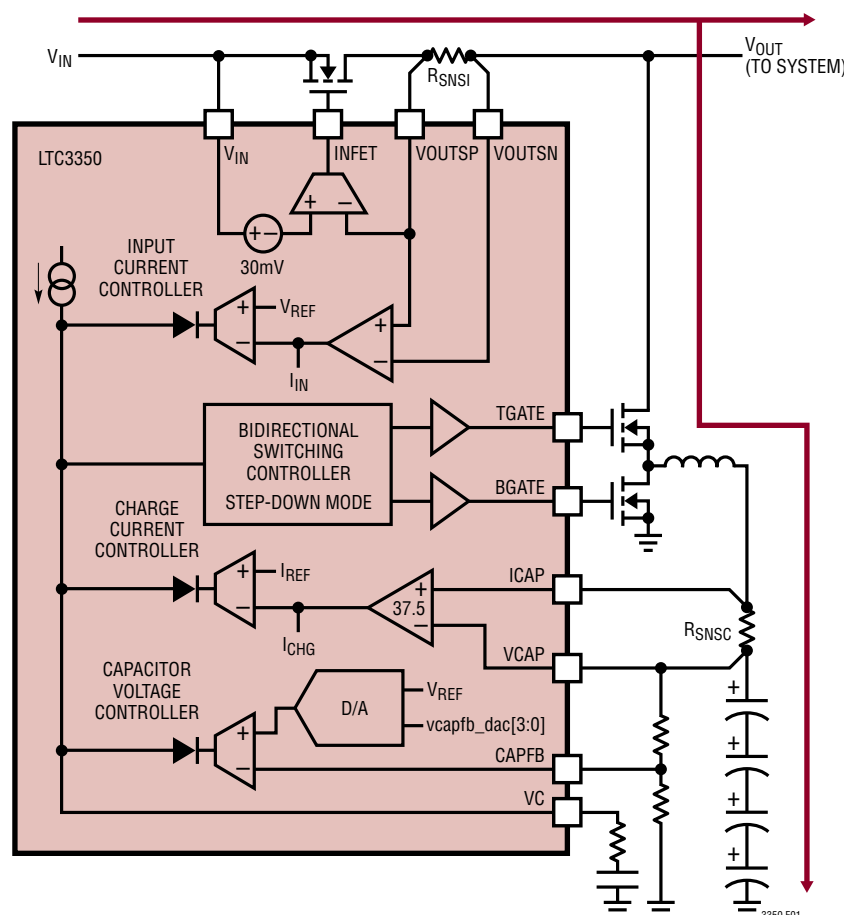

Figure 1. Power Path Block Diagram—Power Available from V_{IN}

The LTC3350 provides constant power charging (for a fixed V_{IN}) by limiting the input current drawn by the switching controller in step-down mode. The input current limit will reduce charge current to limit the voltage across the input sense resistor, R_{SNSI} , to 32mV. If the combined system load plus supercapacitor charge current is large enough to cause the switching controller to reach the programmed input current limit, the input current limit loop will reduce the charge current by precisely the amount necessary to enable the external load to be satisfied. Even if the charge current is programmed to exceed the allowable input current, the input current will not be violated; the supercapacitor charger will reduce its current as needed. Note that the part's quiescent and gate drive currents are not included in the input current measurement. The input current can be read from the `meas_iin` register.

Bidirectional Switching Controller—Step-Up Mode

The bidirectional switching controller acts as a step-up converter to provide power from the supercapacitors to V_{OUT} when input power is unavailable (Figure 2). The PFI comparator enables step-up mode. V_{OUT} regulation is set by a resistor divider between V_{OUT} and $OUTFB$. To disable step-up mode tie $OUTFB$ to $INTV_{CC}$.

Step-up mode can be used in conjunction with the output ideal diode. The V_{OUT} regulation voltage can be set below the capacitor stack voltage. Upon removal of input power, power to V_{OUT} will be provided from the supercapacitor stack via the output ideal diode. V_{CAP} and V_{OUT} will fall as the load current discharges the supercapacitor stack. The output ideal diode will shut off when the voltage on $OUTFB$ falls below 1.3V and V_{OUT} will fall a PN diode (~700mV) below V_{CAP} . If $OUTFB$ falls below 1.2V when the output

OPERATION

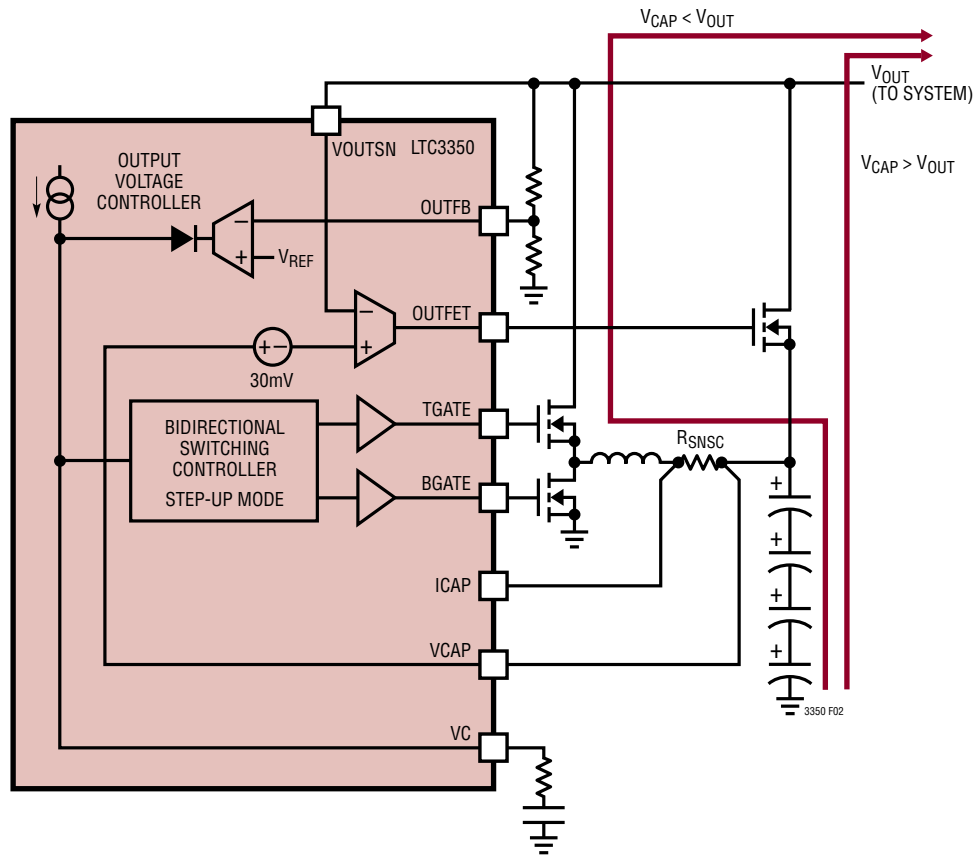

Figure 2. Power Path Block Diagram—Power Backup

ideal diode shuts off, the synchronous controller will turn on immediately. If OUTFB is above 1.2V when the output ideal diode shuts off, the load current will flow through the body diode of the output ideal diode N-channel MOSFET for a period of time until OUTFB falls to 1.2V. The synchronous controller will regulate OUTFB to 1.2V when it turns on, holding up V_{OUT} while the supercapacitors discharge to ground.

The synchronous controller in step-up mode will run nonsynchronously when V_{CAP} is less than 100mV below V_{OUT} . It will run synchronously when V_{CAP} falls 200mV below V_{OUT} .

Ideal Diodes

The LTC3350 has two ideal diode controllers that drive external N-channel MOSFETs. The ideal diodes consist of a precision amplifier that drives the gates of N-channel MOSFETs whenever the voltage at V_{OUT} is approximately

30mV (V_{FWD}) below the voltage at V_{IN} or V_{CAP} . Within the amplifier's linear range, the small-signal resistance of the ideal diode will be quite low, keeping the forward drop near 30mV. At higher current levels, the MOSFETs will be in full conduction.

The input ideal diode prevents the supercapacitors from back driving V_{IN} during backup mode. A Fast-Off comparator shuts off the N-channel MOSFET if V_{IN} falls 30mV below V_{OUT} . The PFI comparator also shuts off the MOSFET during power failure.

The output ideal diode provides a path for the supercapacitors to power V_{OUT} when V_{IN} is unavailable. In addition to a Fast-Off comparator, the output ideal diode also has a Fast-On comparator that turns on the external MOSFET when V_{OUT} drops 65mV below V_{CAP} . The output ideal diode will shut off when OUTFB is just above regulation allowing the synchronous controller to power V_{OUT} in step-up mode.

OPERATION

Gate Drive Supply (DRV_{CC})

The bottom gate driver is powered from the DRV_{CC} pin. It is normally connected to the INTV_{CC} pin. An external LDO can also be used to power the gate drivers to minimize power dissipation inside the IC. See the Applications Information section for details.

Undervoltage Lockout (UVLO)

Internal undervoltage lockout circuits monitor both the INTV_{CC} and DRV_{CC} pins. The switching controller is kept off until INTV_{CC} rises above 4.3V and DRV_{CC} rises above 4.2V. Hysteresis on the UVLOs turn off the controller if either INTV_{CC} falls below 4V or DRV_{CC} falls below 3.9V.

Charging is not enabled until VOUTSN is 185mV above the supercapacitor voltage and V_{IN} is above the PFI threshold. Charging is disabled when VOUTSN falls to within 90mV of the supercapacitor voltage or V_{IN} is below the PFI threshold.

RT Oscillator and Switching Frequency

The RT pin is used to program the switching frequency. A resistor, R_T, from this pin to ground sets the switching frequency according to:

$$f_{sw} \text{ (MHz)} = \frac{53.5}{R_T \text{ (k}\Omega\text{)}}$$

R_T also sets the scale factor for the capacitor measurement value reported in the meas_cap register, described in the Capacitance and ESR Measurement section of this data sheet.

Input Overvoltage Protection

The LTC3350 has overvoltage protection on its input. If V_{IN} exceeds 38.6V, the switching controller will hold the switching MOSFETs off. The controller will resume switching if V_{IN} falls below 37.2V. The input ideal diode MOSFET remains on during input overvoltage.

V_{CAP} DAC

The feedback reference for the CAPFB servo point can be programmed using an internal 4-bit digital-to-analog converter (DAC). The reference voltage can be programmed from 0.6375V to 1.2V in 37.5mV increments. The DAC

defaults to full scale (1.2V) and is programmed via the vcapfb_dac register.

Supercapacitors lose capacitance as they age. By initially setting the V_{CAP} DAC to a low setting, the final charge voltage on the supercapacitors can be increased as they age to maintain a constant level of stored backup energy throughout the lifetime of the supercapacitors.

Power-Fail (PF) Comparator

The LTC3350 contains a fast power-fail (PF) comparator which switches the part from charging to backup mode in the event the input voltage, V_{IN}, falls below an externally programmed threshold voltage. In backup mode, the input ideal diode shuts off and the supercapacitors power the load either directly through the output ideal diode or through the synchronous controller in step-up mode.

The PF comparator threshold voltage is programmed by an external resistor divider via the PFI pin. The output of the PF comparator also drives the gate of an open-drain NMOS transistor to report the status via the PFO pin. When input power is available the PFO pin is high impedance. When V_{IN} falls below the PF comparator threshold, PFO is pulled down to ground.

The output of the PF comparator may also be read from the chrg_pfo bit in the chrg_status register.

Charge Status Indication

The LTC3350 includes a comparator to report the status of the supercapacitors via an open-drain NMOS transistor on the CAPGD pin. This pin is pulled to ground until the CAPFB pin voltage rises to within 8% of the V_{CAP} DAC setting. Once the CAPFB pin is above this threshold, the CAPGD pin goes high impedance.

The output of this comparator may also be read from the chrg_cappg bit in the chrg_status register.

Capacitor Voltage Balancer

The LTC3350 has an integrated active stack balancer. This balancer slowly balances all of the capacitor voltages to within about 10mV of each other. This maximizes the life of the supercapacitors by keeping the voltage on each as low as possible to achieve the needed total stack voltage.

OPERATION

When the difference between any two capacitor voltages exceeds about 10mV, the capacitor with the largest voltage is discharged with a resistive balancer at about 10mA until all capacitor voltages are within 10mV. The balancers are disabled in backup mode.

Capacitor Shunt Regulators

In addition to balancing, there is a need to protect each capacitor from overvoltage during charging. The capacitors in the stack will not have exactly the same capacitance due to manufacturing tolerances or uneven aging. This will cause the capacitor voltages to increase at different rates with the same charge current. If this mismatch is severe enough or if the capacitors are being charged to near their maximum voltage, it becomes necessary to limit the voltage increase on some capacitors while still charging the other capacitors. Up to 500mA of current may be shunted around a capacitor whose voltage is approaching the programmable shunt voltage. This shunt current reduces the charge rate of that capacitor relative to the other capacitors. If a capacitor continues to approach its shunt voltage, the charge current is reduced. This protects the capacitor from overvoltage while still charging the other capacitors, although at a reduced rate of charge. The shunt voltage is programmable in the `vshunt` register. Shunt voltages up to 3.6V may be programmed in 183.5 μ V increments. The shunt regulators can be disabled by programming `vshunt` to zero (0x0000). The default value is 0x3999, resulting in a shunt voltage of 2.7V.

I²C/SMBus and SMBALERT

The LTC3350 contains an I²C/SMBus port. This port allows communication with the LTC3350 for configuration and reading back telemetry data. The port supports two SMBus formats, read word and write word. Refer to the SMBus specification for details of these formats. The registers accessible via this port are organized on an 8-bit address bus and each register is 16 bits wide. The “command code” (or sub-address) of the SMBus read/write word formats is the 8-bit address of each of these registers. The address of the LTC3350 is 0b0001001.

The `SMBALERT` pin is asserted (pulled low) whenever an enabled limit is exceeded or when an enabled status event

happens (see Limit Check and Alarms and Monitor Status Register). The LTC3350 will deassert the `SMBALERT` pin only after responding to an SMBus alert response address (ARA), an SMBus protocol used to respond to a `SMBALERT`. The host will read from the ARA (0b0001100) and each part asserting `SMBALERT` will begin to respond with its address. The responding parts arbitrate in such a way that only the part with the lowest address responds. Only when a part has responded with its address does it release the `SMBALERT` signal. If multiple parts are asserting the `SMBALERT` signal then multiple reads from the ARA are needed. For more information refer to the SMBus specification.

Details on the registers accessible through this interface are available in the Register Map and Register Descriptions sections of this data sheet.

Analog-to-Digital Converter

The LTC3350 has an integrated 14-bit sigma-delta analog-to-digital converter (ADC). This converter is automatically multiplexed between all of the measured channels and its results are stored in registers accessible via the I²C/SMBus port. There are 11 channels measured by the ADC, each of which takes approximately 1.6ms to measure. In addition to providing status information about the system voltages and currents, some of these measurements are used by the LTC3350 to balance, protect, and measure the capacitors in the stack.

The result of the analog-to-digital conversion is stored in a 16-bit register as a signed, two’s complement number. The lower two bits of this number are sub-bits. These bits are ADC outputs which are too noisy to be reliably used on any single conversion, however, they may be included if multiple samples are averaged.

The measurements from the ADC are directly stored in the `meas_vcap1`, `meas_vcap2`, `meas_vcap3`, `meas_vcap4`, `meas_gpi`, `meas_vin`, `meas_vcap`, `meas_vout`, `meas_iin`, `meas_ichg` and `meas_dtemp` registers.

Capacitance and ESR Measurement

The LTC3350 has the ability to measure the capacitance and equivalent series resistance (ESR) of its supercapacitor

OPERATION

stack. This measurement is performed with minimal impact to the system, and can be done while the supercapacitor backup system is online. This measurement discharges the capacitor stack by a small amount (200mV). If input power fails during this test, the part will go into backup mode and the test will terminate.

The capacitance test is performed only once the supercapacitors have finished charging. The test temporarily disables the charger, then discharges the supercapacitors by 200mV with a precision current. The discharge time is measured and used to calculate the capacitance with the result of this measurement stored in the `meas_cap` register. The number reported is proportional to the capacitance of the entire stack. Two different scales can be set using the `ctl_cap_scale` bit in the `ctl_reg` register. If `ctl_cap_scale` is set to 0 (for large value capacitor stacks), use the following equation to convert the `meas_cap` value to Farads:

$$C_{\text{STACK}} = \frac{R_T}{R_{\text{TST}}} \cdot 336\mu\text{F} \cdot \text{meas_cap}$$

If `ctl_cap_scale` is set to 1 (for small value capacitor stacks), use the following equation to convert the `meas_cap` value to Farads:

$$C_{\text{STACK}} = \frac{R_T}{R_{\text{TST}}} \cdot 3.36\mu\text{F} \cdot \text{meas_cap}$$

In the two previous equations R_T is the resistor on the RT pin and R_{TST} is the resistor on the ITST pin.

The ESR test is performed immediately following the capacitance test. The switching controller is switched on and off several times. The changes in charge current and stack voltage are measured. These measurements are used to calculate the ESR relative to the charge current sense resistor. The result of this measurement is stored in the `meas_esr` register. The value reported in `meas_esr` can be converted to ohms using the following equation:

$$R_{\text{ESR}} = \frac{R_{\text{SNSC}}}{64} \cdot \text{meas_esr}$$

where R_{SNSC} is the charge current sense resistor in series with the inductor.

The capacitance and capacitor ESR measurements do not automatically run as the other measurements do. They must be initiated by setting the `ctl_strt_capesr` bit in the `ctl_reg` register. This bit will automatically clear once the measurement begins. If the `cap_esr_per` register is set to a non-zero value, the measurement will be repeated after the time programmed in the `cap_esr_per` register. Each LSB in the `cap_esr_per` register represents 10 seconds.

The capacitance and ESR measurements may fail to complete for several reasons, in which case the respective `mon_cap_failed` or `mon_esr_failed` bit will be set. The capacitance test may fail due to a power failure or if the 200mV discharge trips the CAPGD comparator. The ESR test will also fail if the capacitance test fails. The ESR test uses the charger to supply a current and then measures the supercapacitor stack voltage with and without that current. If the ESR is greater than 1024 times R_{SNSC} , the ESR measurement will fail. The ESR measurement is adaptive; it uses knowledge of the ESR from previous measurements to program the test current. The capacitance and ESR tests should initially be run several times when first powering up to get the most accuracy out of the system. It is possible for the first few measurements to give low quality results or fail to complete and after running several times will complete with a quality result. The leakage on supercapacitors is initially very high after being charged. Many supercapacitor manufacturers specify the leakage current after being charged for 72 hours. It is expected that capacitor measurements conducted prior to this time will read low.

Monitor Status Register

The LTC3350 has a monitor status register (`mon_status`) which contains status bits indicating the state of the capacitance and ESR monitoring system. These bits are set and cleared by the capacitor monitor upon certain events during a capacitor and ESR measurement, as described in the Capacitance and ESR Measurement section.

There is a corresponding `msk_mon_status` register. Writing a one to any of these bits will cause the `SMBALERT` pin to pull low when the corresponding bit in the `msk_mon_status` register has a rising edge. This allows reduced polling of the LTC3350 when waiting for a capacitance or ESR measurement to complete.

OPERATION

Details of the `mon_status` and `msk_mon_status` registers can be found in the Register Descriptions section of this data sheet.

Charge Status Register

The LTC3350 charger status register (`chrg_status`) contains data about the state of the charger, switcher, shunts, and balancers. Details of this register may be found in the Register Description sections of this data sheet.

Limit Checking and Alarms

The LTC3350 has a limit checking function that will check each measured value against I²C/SMBus programmable limits. This feature is optional, and all the limits are disabled by default. The limit checking is designed to simplify system monitoring, eliminating the need to continuously poll the LTC3350 for measurement data.

If a measured parameter goes outside of the programmed level of an enabled limit, the associated bit in the `alarm_reg` register is set high and the `SMBALERT` pin is pulled low. This informs the I²C/SMBus host a limit has been exceeded. The alarms register may then be read to determine exactly which programmed limits have been exceeded.

A single ADC is shared between the 11 channels with about 18ms between consecutive measurements of the same channel. In a transient condition, it is possible for these parameters to exceed their programmed levels in between consecutive ADC measurements without setting the alarm.

Once the LTC3350 has responded to an SMBus ARA the `SMBALERT` pin is released. The part will not pull the pin low again until another limit is exceeded. To reset a limit that has been exceeded, it must be cleared by writing a one to the respective bit in the `clr_alarms` register.

A number of the LTC3350's registers are used for limit checking. Individual limits are enabled or disabled in the `msk_alarms` registers. Once an enabled alarm's measured value exceeds the programmed level for that alarm the alarm is set. That alarm may be cleared by writing a one to the appropriate bit of the `clr_alarms` register or by writing a zero to the appropriate bit to the `msk_alarms` register. All alarms that have been set and have not yet been cleared may be read in the `alarm_reg` register.

All of the individual measured voltages have a corresponding undervoltage (`uv`) and overvoltage (`ov`) alarm level. All of the individual capacitor voltages are compared to the same alarm levels, set in the `cap_ov_lvl` and `cap_uv_lvl` registers. The input current measurement has an overcurrent (`oc`) alarm programmed in the `iin_oc_lvl` register. The charge current has an undercurrent alarm programmed in the `ichg_uc_lvl` register.

Die Temperature Sensor

The LTC3350 has an integrated die temperature sensor monitored by the ADC and digitized to the `meas_dtemp` register. An alarm may be set on die temperature by setting the `dtemp_cold_lvl` and/or `dtemp_hot_lvl` registers and enabling their respective alarms in the `msk_alarms` register. To convert the code in the `meas_dtemp` register to degrees Celsius use the following:

$$T_{DIE} (\text{°C}) = 0.028 \cdot \text{meas_dtemp} - 251.4$$

General Purpose Input

The general purpose input (GPI) pin can be used to measure an additional system parameter. The voltage on this pin is directly digitized by the ADC. For high impedance inputs, an internal buffer may be selected and used to drive the ADC. This buffer is enabled by setting the `ctl_gpi_buffer_en` bit in the `ctl_reg` register. With this buffer, the input range is limited from 0V to 3.5V. If this buffer is not used, the range is from 0V to 5V, however, the input stage of the ADC will draw about 0.4μA per volt from this pin. The ADC input is a switched capacitor amplifier running at about 1MHz, so this current draw will be at that frequency. The pin current can be eliminated at the cost of reduced range and increased offset by enabling the buffer.

Alarms are available for this pin voltage with levels programmed using the `gpi_uv_lvl` and `gpi_ov_lvl` registers. These alarms are enabled using the `msk_gpi_uv` and `msk_gpi_ov` bits in the `msk_alarms` register.

To monitor the temperature of the supercapacitor stack, the GPI pin can be connected to a negative temperature coefficient (NTC) thermistor. A low drift bias resistor is required from `INTVCC` to GPI and a thermistor is required from GPI to ground. Connect GPI to `SGND` if not used.

APPLICATIONS INFORMATION

Digital Configuration

Although the LTC3350 has extensive digital features, only a few are required for basic use. The shunt voltage should be programmed via the `vshunt` register if a value other than the default 2.7V is required. The capacitor voltage feedback reference defaults to 1.2V; it may be changed in the `vcapfb_dac` register.

All other digital features are optional and used for monitoring. The ADC automatically runs and stores conversions to registers (e.g., `meas_vcap`). Capacitance and ESR measurements only run if requested, however, they may be scheduled to repeat if desired (`ctl_strt_capesr` and `cap_esr_per`). Each measured parameter has programmable limits (e.g., `vcap_uv_lvl` and `vcap_ov_lvl`) which may trigger an alarm and `SMBALERT` when enabled. These alarms are disabled by default.

Capacitor Configuration

The LTC3350 may be used with one to four supercapacitors. If less than four capacitors are used, the capacitors must be populated from `CAPRTN` to `CAP4`, and the unused `CAP` pins must be tied to the highest used `CAP` pin. For example, if three capacitors are used, `CAP4` should be tied to `CAP3`. If only two capacitors are used, both `CAP4` and `CAP3` should be tied to `CAP2`. The number of capacitors used must be programmed on the `CAP_SLCT0` and `CAP_SLCT1` pins by tying the pins to `VCC2P5` for a one and ground for a zero as shown in Table 1. The value programmed on these pins may be read back from the `num_caps` register via `I2C/SMBus`.

Table 1

CAP_SLCT1	CAP_SLCT0	num_caps REGISTER VALUE	NUMBER OF CAPACITORS
0	0	0	1
0	1	1	2
1	0	2	3
1	1	3	4

Capacitor Shunt Regulator Programming

V_{SHUNT} is programmed via the `I2C/SMBus` interface and defaults to 2.7V at initial power-up. V_{SHUNT} serves to limit the voltage on any individual capacitor by turning on a shunt around that capacitor as the voltage approaches

V_{SHUNT} . `CAPRTN`, `CAP1`, `CAP2`, `CAP3` and `CAP4` must be connected to the supercapacitors through resistors which serve as ballasts for the internal shunts. The shunt current is approximately V_{SHUNT} divided by twice the shunt resistance value. For a V_{SHUNT} of 2.7V, 2.7 Ω resistors should be used for 500mA of shunt current. The shunts have a duty cycle of up to 75%. The power dissipated in a single shunt resistor is approximately:

$$P_{SHUNT} \approx \frac{3V_{SHUNT}^2}{16R_{SHUNT}}$$

and the resistors should be sized accordingly. If the shunts are disabled, make R_{SHUNT} 100 Ω .

Since the shunt current is less than what the switcher can supply, the on-chip logic will automatically reduce the charging current to allow the shunt to protect the capacitor. This greatly reduces the charge rate once any one shunt is activated. For this reason, V_{SHUNT} should be programmed as high as possible to reduce the likelihood of it activating during a charge cycle. Ideally, V_{SHUNT} would be set high enough so that any likely capacitor mismatches would not cause the shunts to turn on. This keeps the charger operating at the highest possible charge current and reduces the charge time. If the shunts never turn on, the charge cycle completes quickly and the balancers eventually equalize the voltage on the capacitors. The shunt setting may also be used to discharge the capacitors for testing, storage or other purposes.

Setting Input and Charge Currents

The maximum input current is determined by the resistance across the `VOUTSP` and `VOUTSN` pins, R_{SNSI} . The maximum charge current is determined by the value of the sense resistor, R_{SNSC} , used in series with the inductor. The input and charge current loops servo the voltage across their respective sense resistor to 32mV. Therefore, the maximum input and charge currents are:

$$I_{IN(MAX)} = \frac{32mV}{R_{SNSI}}$$

$$I_{CHG(MAX)} = \frac{32mV}{R_{SNSC}}$$

APPLICATIONS INFORMATION

The peak inductor current limit, I_{PEAK} , is 80% higher than the maximum charge current and is equal to:

$$I_{PEAK} = \frac{58mV}{R_{SNSC}}$$

Note that the input current limit does not include the part's quiescent and gate drive currents. The total current drawn by the part will be $I_{IN(MAX)} + I_Q + I_G$, where I_Q is the non-switching quiescent current and I_G is the gate drive current.

Low Current Charging and High Current Backup

The LTC3350 can accommodate applications requiring low charge currents and high backup currents. In these applications, program the desired charge current using R_{SNSI} . The higher current needed during backup can be set using R_{SNSC} . The input current limit will override the charge current limit when the supercapacitors are charging while the charge current limit provides sufficient current capability for backup operation.

The charge current will be limited to $I_{CHG(MAX)}$ at low V_{CAP} (i.e., low duty cycles). As V_{CAP} rises, the switching controller's input current will increase until it reaches $I_{IN(MAX)}$. The input current will be maintained at $I_{IN(MAX)}$ and the charge current will decrease as V_{CAP} rises further.

Some applications may want to use only a portion of the input current limit to charge the supercapacitors. Two input current sense resistors placed in series can be used to accomplish this as shown in Figure 3. V_{OUTSP} is kelvin connected to the positive terminal of R_{SNSI1} and V_{OUTSN} is kelvin connected to the negative terminal of R_{SNSI2} . The load current is pulled across R_{SNSI1} while the input current to the charger is pulled across R_{SNSI1} and R_{SNSI2} . The input current limit is:

$$32mV = R_{SNSI1} \cdot I_{LOAD} + (R_{SNSI1} + R_{SNSI2}) \cdot I_{INCHG}$$

For example, suppose that only 2A of input current is desired to charge the supercapacitors but the system load and charger combined can pull a total of up to 4A from the supply. Setting $R_{SNSI1} = R_{SNSI2} = 8m\Omega$ will set a 4A current limit for the load + charger while setting a 2A limit for the charger. With no system load, the charger can pull up to 2A of input current. As the load pulls 0A to 4A of current the charger's input current will reduce from 2A down to 0A.

The following equation can be used to determine charging input current as a function of system load current:

$$I_{INCHG} = \frac{32mV}{R_{SNSI1} + R_{SNSI2}} - \frac{R_{SNSI1}}{R_{SNSI1} + R_{SNSI2}} \cdot I_{LOAD}$$

The contact resistance of the negative terminal of R_{SNSI1} and the positive terminal of R_{SNSI2} as well as the resistance of the trace connecting them will cause variability in the input current limit. To minimize the error, place both input current sense resistors close together with a large PCB pad area between them as the system load current is pulled from the trace connecting the two sense resistors.

Note that the backup current will flow through R_{SNSI2} . The R_{SNSI2} package should be sized accordingly to handle the power dissipation.

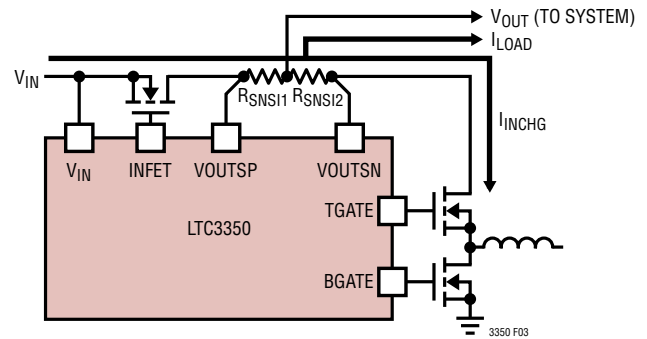

Figure 3

Setting V_{CAP} Voltage

The LTC3350 V_{CAP} voltage is set by an external feedback resistor divider, as shown in Figure 4. The regulated output voltage is determined by:

$$V_{CAP} = \left(1 + \frac{R_{FBC1}}{R_{FBC2}} \right) CAPFBREF$$

where $CAPFBREF$ is the output of the V_{CAP} DAC, programmed in the `vcapfb_dac` register. Great care should be taken to route the $CAPFB$ line away from noise sources, such as the SW line.

Power-Fail Comparator Input Voltage Threshold

The input voltage threshold below which the power-fail status pin, \overline{PFO} , indicates a power-fail condition and the

APPLICATIONS INFORMATION

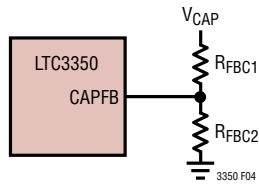

Figure 4. V_{CAP} Voltage Feedback Divider

LTC3350 bidirectional controller switches to step-up mode is programmed using a resistor divider from the V_{IN} pin to SGND via the PFI pin such that:

$$V_{IN} = \left(1 + \frac{R_{PF1}}{R_{PF2}} \right) V_{PFI(TH)}$$

where $V_{PFI(TH)}$ is 1.17V. Typical values for R_{PF1} and R_{PF2} are in the range of 40k to 1M. See Figure 5.

The input voltage above which the power-fail status pin \overline{PFO} is high impedance and the bidirectional controller switches to step-down mode is:

$$V_{IN} = \left(1 + \frac{R_{PF1}}{R_{PF2}} \right) (V_{PFI(TH)} + V_{PFI(HYS)})$$

where $V_{PFI(HYS)}$ is the hysteresis of the PFI comparator and is equal to 30mV.

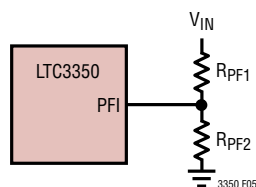

Figure 5. PFI Threshold Voltage Divider

Additional hysteresis can be added by switching in an additional resistor, R_{PF3} , in parallel with R_{PF2} when the voltage at PFI falls below 1.17V as shown in Figure 6. The falling V_{IN} threshold is the same as before but the rising V_{IN} threshold becomes:

$$V_{IN} = \left(1 + \frac{R_{PF1}}{R_{PF2}} + \frac{R_{PF1}}{R_{PF3}} \right) (V_{PFI(TH)} + V_{PFI(HYST)})$$

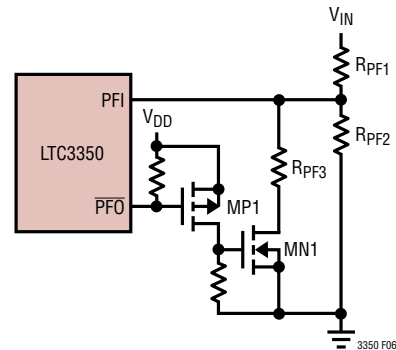

Figure 6. PFI Threshold Divider with Added Hysteresis

MN1 and MP1 can be implemented with a single package N-channel and P-channel MOSFET pair such as the Si1555DL or Si1016CX. The drain leakage current of MN1, when its gate voltage is at ground, can introduce an offset in the threshold. To minimize the effect of this leakage current R_{PF1} , R_{PF2} and R_{PF3} should be between 1k and 100k.

Setting V_{OUT} Voltage in Backup Mode

The output voltage for the controller in step-up mode is set by an external feedback resistor divider, as shown in Figure 7. The regulated output voltage is determined by:

$$V_{OUT} = \left(1 + \frac{R_{FBO1}}{R_{FBO2}} \right) 1.2V$$

Great care should be taken to route the $OUTFB$ line away from noise sources, such as the SW line.

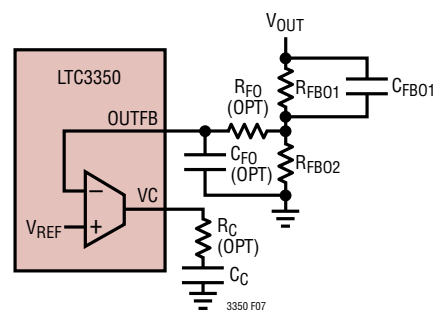

Figure 7. V_{OUT} Voltage Divider and Compensation Network

APPLICATIONS INFORMATION

Compensation

The input current, charge current, V_{CAP} voltage, and V_{OUT} voltage loops all require a 1nF to 10nF capacitor from the VC node to ground. When using the output ideal diode and backing up to low voltages (<8V) use 8.2nF to 10nF on VC. When not using the output ideal diode 4.7nF to 10nF on VC is recommended. For very high backup voltages (>15V) 1nF to 4.7nF is recommended.

In addition to the VC node capacitor, the V_{OUT} voltage loop requires a phase-lead capacitor, C_{FB01} , for stability and improved transient response during input power failure (Figure 7). The product of the top divider resistor and the phase-lead capacitor should be used to create a zero at approximately 2kHz:

$$R_{FB01} \cdot C_{FB01} \approx \frac{1}{2\pi(2\text{kHz})}$$

Choose an R_{FB01} such that C_{FB01} is $\geq 100\text{pF}$ to minimize the effects of parasitic pin capacitance. Because the phase-lead capacitor introduces a larger ripple at the input of the V_{OUT} transconductance amplifier, an additional RC lowpass filter from the V_{OUT} divider to the OUTFB pin may be needed to eliminate voltage ripple spikes. The filter time constant should be located at the switching frequency of the synchronous controller:

$$R_{FO} \cdot C_{FO} = \frac{1}{2\pi f_{SW}}$$

with $C_{FO} > 10\text{pF}$ to minimize the effects of parasitic pin capacitance. For back up applications where the V_{OUT} regulation voltage is low (~5V to 6V), an additional 1k to 3k resistor, R_C , in series with the VC capacitor can improve stability and transient response.

Minimum V_{CAP} Voltage in Backup Mode

In backup mode, power is provided to the output from the supercapacitors either through the output ideal diode or the synchronous controller operating in step-up mode.

The output ideal diode provides a low loss power path from the supercapacitors to V_{OUT} . The minimum internal (open-circuit) supercapacitor voltage will be equal to the minimum V_{OUT} necessary for the system to operate plus the voltage drops due to the output ideal diode and equivalent series resistance, R_{SC} , of each supercapacitor in the stack.

Example: System needs 5V to run and draws 1A during backup. There are four supercapacitors in the stack, each with an R_{SC} of 45m Ω . The output ideal diode forward regulation voltage is 30mV (OUTFET $R_{DS(ON)} < 30\text{m}\Omega$). The minimum open-circuit supercapacitor voltage is:

$$V_{CAP(MIN)} = 5\text{V} + 0.030\text{V} + (1\text{A} \cdot 4 \cdot 45\text{m}\Omega) = 5.21\text{V}$$

Using the synchronous controller in step-up mode allows the supercapacitors to be discharged to a voltage much lower than the minimum V_{OUT} needed to run the system. The amount of power that the supercapacitor stack can deliver at its minimum internal (open-circuit) voltage should be greater than what is needed to power the output and the step-up converter.

According to the maximum power transfer rule:

$$P_{CAP(MIN)} = \frac{V_{CAP(MIN)}^2}{4 \cdot n \cdot R_{SC}} > \frac{P_{BACKUP}}{\eta}$$

In the equation above η is the efficiency of the synchronous controller in step-up mode and n is the number of supercapacitors in the stack.

Example: System needs 5V to run and draws 1A during backup. There are four supercapacitors in the stack ($n = 4$), each with an R_{SC} of 45m Ω . The converter efficiency is 90%. The minimum open-circuit supercapacitor voltage is:

$$V_{CAP(MIN)} = \sqrt{\frac{4 \cdot 4 \cdot 45\text{m}\Omega \cdot 5\text{V} \cdot 1\text{A}}{0.9}} = 2.0\text{V}$$

In this case, the voltage seen at the terminals of the capacitor stack is half this voltage, or 1V, according to the maximum power transfer rule.

APPLICATIONS INFORMATION

Note the minimum V_{CAP} voltage can also be limited by the peak inductor current limit (180% of maximum charge current) and the maximum duty cycle in step-up mode (~90%).

Optimizing Supercapacitor Energy Storage Capacity

In most systems the supercapacitors will provide backup power to one or more DC/DC converters. A DC/DC converter presents a constant power load to the supercapacitor. When the supercapacitors are near their maximum voltage, the loads will draw little current. As the capacitors discharge, the current drawn from supercapacitors will increase to maintain constant power to the load. The amount of energy required in back up mode is the product of this constant backup power, P_{BACKUP} , and the backup time, t_{BACKUP} .

The energy stored in a stack of n supercapacitors available for backup is:

$$\frac{1}{2} n C_{SC} (V_{CELL(MAX)}^2 - V_{CELL(MIN)}^2)$$

where C_{SC} , $V_{CELL(MAX)}$ and $V_{CELL(MIN)}$ are the capacitance, maximum voltage and minimum voltage of a single capacitor in the stack, respectively. The maximum voltage on the stack is $V_{CAP(MAX)} = n \cdot V_{CELL(MAX)}$. The minimum voltage on the stack is $V_{CAP(MIN)} = n \cdot V_{CELL(MIN)}$.

Some of this energy will be dissipated as conduction loss in the ESR of the supercapacitor stack. A higher backup power requirement leads to a higher conduction loss for a given stack ESR.

The amount of capacitance needed can be found by solving the following equation for C_{SC} :

$$P_{BACKUP} \cdot t_{BACKUP} = \frac{1}{4} n C_{SC} \left[\gamma_{MAX} \cdot V_{CELL(MAX)}^2 - \gamma_{MIN} \cdot V_{CELL(MIN)}^2 - \frac{4R_{SC} \cdot P_{BACKUP}}{n} \ln \left(\frac{\gamma_{MAX} \cdot V_{CELL(MAX)}}{\gamma_{MIN} \cdot V_{CELL(MIN)}} \right) \right]$$

where:

$$\gamma_{MAX} = 1 + \sqrt{1 - \frac{4R_{SC} \cdot P_{BACKUP}}{nV_{CELL(MAX)}^2}} \text{ and,}$$

$$\gamma_{MIN} = 1 + \sqrt{1 - \frac{4R_{SC} \cdot P_{BACKUP}}{nV_{CELL(MIN)}^2}}$$

R_{SC} is the equivalent series resistance (ESR) of a single supercapacitor in the stack. Note that the maximum power transfer rule limits the minimum cell voltage to:

$$V_{CELL(MIN)} = \frac{V_{CAP(MIN)}}{n} \geq \sqrt{\frac{4R_{SC} \cdot P_{BACKUP}}{n}}$$

To minimize the size of the capacitance for a given amount of backup energy, the maximum voltage on the stack, $V_{CELL(MAX)}$, can be increased. However, the voltage is limited to a maximum of 2.7V and this may lead to an unacceptably low capacitor lifetime.

An alternative option would be to keep $V_{CELL(MAX)}$ at a voltage that leads to reasonably long lifetime and increase the capacitor utilization ratio of the supercapacitor stack. The capacitor utilization ratio, α_B , can be defined as:

$$\alpha_B = \frac{V_{CELL(MAX)}^2 - V_{CELL(MIN)}^2}{V_{CELL(MAX)}^2}$$

If the synchronous controller in step-up mode is used then the supercapacitors can be run down to a voltage set by the

APPLICATIONS INFORMATION

maximum power transfer rule to maximize the utilization ratio. The minimum voltage in this case is:

$$V_{\text{CELL(MIN)}} = \sqrt{\frac{4R_{\text{SC}} \cdot P_{\text{BACKUP}}}{n\eta}}$$

where η is the efficiency of the boost converter (~90% to 96%). For the backup equation, γ_{MAX} and γ_{MIN} , substitute P_{BACKUP}/η for P_{BACKUP} . In this case the energy needed for backup is governed by the following equation:

$$\frac{P_{\text{BACKUP}}}{\eta} t_{\text{BACKUP}} \leq \frac{1}{2} n C_{\text{SC}} \cdot V_{\text{CELL(MAX)}}^2 \cdot \left[\frac{\alpha_B + \sqrt{\alpha_B}}{2} - \frac{1 - \alpha_B}{2} \ln \left(\frac{1 + \sqrt{\alpha_B}}{\sqrt{1 - \alpha_B}} \right) \right]$$

Once a capacitance is found using the above equation the maximum ESR allowed needs to be checked:

$$R_{\text{SC}} \leq \frac{\eta(1 - \alpha_B) n V_{\text{CELL(MAX)}}^2}{4 P_{\text{BACKUP}}}$$

Capacitor Selection Procedure

1. Determine backup requirements P_{BACKUP} and t_{BACKUP} .
2. Determine maximum cell voltage that provides acceptable capacitor lifetime.
3. Choose number of capacitors in the stack.
4. Choose a desired utilization ratio, α_B , for the supercapacitor (e.g., 80%).
5. Solve for capacitance, C_{SC} :

$$C_{\text{SC}} \geq \frac{2 P_{\text{BACKUP}} \cdot t_{\text{BACKUP}}}{n \eta V_{\text{CELL(MAX)}}^2}$$

$$\left[\frac{\alpha_B + \sqrt{\alpha_B}}{2} - \frac{1 - \alpha_B}{2} \ln \left(\frac{1 + \sqrt{\alpha_B}}{\sqrt{1 - \alpha_B}} \right) \right]^{-1}$$

6. Find supercapacitor with sufficient capacitance C_{SC} and minimum R_{SC} :

$$R_{\text{SC}} \leq \frac{\eta(1 - \alpha_B) n V_{\text{CELL(MAX)}}^2}{4 P_{\text{BACKUP}}}$$

7. If a suitable capacitor is not available, iterate by choosing more capacitance, a higher cell voltage, more capacitors in the stack and/or a lower utilization ratio.
8. Make sure to take into account the lifetime degradation of ESR and capacitance, as well as the maximum discharge current rating of the supercapacitor. A list of supercapacitor suppliers is provided in Table 2.

Table 2. Supercapacitor Suppliers

AVX	www.avx.com
Bussman	www.cooperbussman.com
CAP-XX	www.cap-xx.com
Illinois Capacitor	www.illcap.com
Maxwell	www.maxwell.com
Murata	www.murata.com
NESS CAP	www.nesscap.com
Tecate Group	www.tecategroup.com

Inductor Selection

The switching frequency and inductor selection are inter-related. Higher switching frequencies allow the use of smaller inductor and capacitor values, but generally results in lower efficiency due to MOSFET switching and gate charge losses. In addition, the effect of inductor value on ripple current must also be considered. The inductor ripple current decreases with higher inductance or higher frequency and increases with higher V_{IN} . Accepting larger values of ripple current allows the use of low inductances but results in higher output voltage ripple and greater core losses.

For the LTC3350, the best overall performance will be attained if the inductor is chosen to be:

$$L = \frac{V_{\text{IN(MAX)}}}{I_{\text{CHG(MAX)}} \cdot f_{\text{SW}}}$$

for $V_{\text{IN(MAX)}} \leq 2V_{\text{CAP}}$ and:

$$L = \left(1 - \frac{V_{\text{CAP}}}{V_{\text{IN(MAX)}}} \right) \frac{V_{\text{CAP}}}{0.25 \cdot I_{\text{CHG(MAX)}} \cdot f_{\text{SW}}}$$

for $V_{\text{IN(MAX)}} \geq 2V_{\text{CAP}}$, where V_{CAP} is the final supercapacitor stack voltage, $V_{\text{IN(MAX)}}$ is the maximum input voltage, $I_{\text{CHG(MAX)}}$ is the maximum regulated charge current, and f_{SW} is the switching frequency. Using these equations, the inductor ripple will be at most 25% of $I_{\text{CHG(MAX)}}$.

3350fc

APPLICATIONS INFORMATION

Using the above equation, the inductor may be too large to provide a fast enough transient response to hold up V_{OUT} when input power goes away. This occurs in cases where the maximum V_{IN} can be high (e.g. 25V) and the backup voltage low (e.g. 6V). In these situations it would be best to choose an inductor that is smaller resulting in maximum peak-to-peak ripple as high as 40% of $I_{CHG(MAX)}$.

Once the value for L is known, the type of inductor core must be selected. Ferrite cores are recommended for their very low core loss. Selection criteria should concentrate on minimizing copper loss and preventing saturation. Ferrite core material saturates “hard,” which means that inductance collapses abruptly when the peak design current is exceeded. This causes an abrupt increase in inductor ripple current and consequent output voltage ripple. Do not allow the core to saturate. The saturation current for the inductor should be at least 80% higher than the maximum regulated current, $I_{CHG(MAX)}$. A list of inductor suppliers is provided in Table 3.

Table 3. Inductor Vendors

VENDOR	URL
Coilcraft	www.coilcraft.com
Murata	www.murata.com
Sumida	www.sumida.com
TDK	www.tdk.com
Toko	www.toko.com
Vishay	www.vishay.com
Würth Electronic	www.we-online.com

C_{OUT} and C_{CAP} Capacitance

V_{OUT} serves as the input to the synchronous controller in step-down mode and as the output in step-up (backup) mode. If step-up mode is used, place 100 μ F of bulk (aluminum electrolytic, OS-CON, POSCAP) capacitance for every 2A of backup current desired. For 5V system applications, 100 μ F per 1A of backup current is recommended. In addition, a certain amount of high frequency bypass capacitance is needed to minimize voltage ripple. The voltage ripple in step-up mode is:

$$\Delta V_{OUT} = \left[\left(1 - \frac{V_{CAP}}{V_{OUT}} \right) \frac{1}{C_{OUT} \cdot f_{SW}} + \frac{V_{OUT}}{V_{CAP}} \cdot R_{ESR} \right] I_{OUT(BACKUP)}$$

Maximum ripple occurs at the lowest V_{CAP} that can supply $I_{OUT(BACKUP)}$. Multilayer ceramics are recommended for high frequency filtering.

If step-up mode is unused, then the specification for C_{OUT} will be determined by the desired ripple voltage in step-down mode:

$$\Delta V_{OUT} = \frac{V_{CAP}}{V_{OUT}} \left(1 - \frac{V_{CAP}}{V_{OUT}} \right) \frac{I_{CHG(MAX)}}{C_{OUT} \cdot f_{SW}} + I_{CHG(MAX)} \cdot R_{ESR}$$

In continuous conduction mode, the source current of the top MOSFET is a square wave of duty cycle V_{CAP}/V_{OUT} . To prevent large voltage transients, a low ESR capacitor sized for the maximum RMS current must be used. The maximum RMS capacitor current is given by:

$$I_{RMS} \cong I_{CHG(MAX)} \frac{V_{CAP}}{V_{OUT}} \sqrt{\frac{V_{OUT}}{V_{CAP}} - 1}$$

This formula has a maximum at $V_{OUT} = 2V_{CAP}$, where $I_{RMS} = I_{CHG(MAX)}/2$. This simple worst-case condition is commonly used for design because even significant deviations do not offer much relief.

Medium voltage (20V to 35V) ceramic, tantalum, OS-CON, and switcher-rated electrolytic capacitors can be used as input capacitors. Sanyo OS-CON SVP, SVPD series, Sanyo POSCAP TQC series, or aluminum electrolytic capacitors from Panasonic WA series or Cornell Dubilier SPV series in parallel with a couple of high performance ceramic capacitors can be used as an effective means of achieving low ESR and high bulk capacitance.

V_{CAP} serves as the input to the controller in step-up mode and as the output in step-down mode. The purpose of the V_{CAP} capacitor is to filter the inductor current ripple. The V_{CAP} ripple (ΔV_{CAP}) is approximated by:

$$\Delta V_{CAP} \approx \Delta I_{PP} \left(\frac{1}{8C_{CAP} \cdot f_{SW}} + R_{ESR} \right)$$

where f_{SW} is the switching frequency, C_{CAP} is the capacitance on V_{CAP} and ΔI_{PP} is the ripple current in the inductor. The output ripple is highest at maximum input voltage since ΔI_{PP} increases with input voltage.

3350fc

APPLICATIONS INFORMATION

Because supercapacitors have low series resistance, it is important that C_{CAP} be sized properly so that the bulk of the inductor current ripple flows through the filter capacitor and not the supercapacitor. It is recommended that:

$$\left(\frac{1}{8C_{CAP} \cdot f_{SW}} + R_{ESR} \right) \leq \frac{n \cdot R_{SC}}{5}$$

where n is the number of supercapacitors in the stack and R_{SC} is the ESR of each supercapacitor. The capacitance on V_{CAP} can be a combination of bulk and high frequency capacitors. Aluminum electrolytic, OS-CON and POSCAP capacitors are suitable for bulk capacitance while multilayer ceramics are recommended for high frequency filtering.

Power MOSFET Selection

Two external power MOSFETs must be selected for the LTC3350's synchronous controller: one N-channel MOSFET for the top switch and one N-channel MOSFET for the bottom switch. The selection criteria of the external N-channel power MOSFETs include maximum drain-source voltage (V_{DSS}), threshold voltage, on-resistance ($R_{DS(ON)}$), reverse transfer capacitance (C_{RSS}), total gate charge (Q_G), and maximum continuous drain current.

V_{DSS} of both MOSFETs should be selected to be higher than the maximum input supply voltage (including transient). The peak-to-peak drive levels are set by the DRV_{CC} voltage. Logic-level threshold MOSFETs should be used because DRV_{CC} is powered from either $INTV_{CC}$ (5V) or an external LDO whose output voltage must be less than 5.5V.

MOSFET power losses are determined by $R_{DS(ON)}$, C_{RSS} and Q_G . The conduction loss at maximum charge current for the top and bottom MOSFET switches are:

$$P_{COND(TOP)} = \frac{V_{CAP}}{V_{OUT}} I_{CHG(MAX)}^2 \cdot R_{DS(ON)} (1 + \delta \Delta T)$$

$$P_{COND(BOT)} = \left(1 - \frac{V_{CAP}}{V_{OUT}} \right) I_{CHG(MAX)}^2 \cdot R_{DS(ON)} (1 + \delta \Delta T)$$

The term $(1 + \delta \Delta T)$ is generally given for a MOSFET in the form of a normalized $R_{DS(ON)}$ vs Temperature curve, but $\delta = 0.005/^\circ\text{C}$ can be used as an approximation for low voltage MOSFETs.

Both MOSFET switches have conduction loss. However, transition loss occurs only in the top MOSFET in step-down mode and only in the bottom MOSFET in step-up mode. These losses are proportional to V_{OUT}^2 and can be considerably large in high voltage applications ($V_{OUT} > 20\text{V}$). The maximum transition loss is:

$$P_{TRAN} \approx \frac{k}{2} V_{OUT}^2 \cdot I_{CHG(MAX)} \cdot C_{RSS} \cdot f_{SW}$$

where k is related to the drive current during the Miller plateau and is approximately equal to one.

The synchronous controller can operate in both step-down and step-up mode with different voltages on V_{OUT} in each mode. If V_{OUT} is 12V in step-down mode (input power available) and 10V in step-up mode (backup mode) then both MOSFETs can be sized to minimize conduction loss. If V_{OUT} can be as high as 25V while charging and V_{OUT} is held to 6V in backup mode, then the MOSFETs should be sized to minimize losses during backup mode. This may lead to choosing a high side MOSFET with significant transition loss which may be tolerable when input power is available so long as thermal issues do not become a limiting factor. The bottom MOSFET can be chosen to minimize conduction loss. If step-up mode is unused, then choosing a high side MOSFET that has a higher $R_{DS(ON)}$ device and lower C_{RSS} would minimize overall losses.

Another power loss related to switching MOSFET selection is the power lost to driving the gates. The total gate charge, Q_G , must be charged and discharged each switching cycle. The power is lost to the internal LDO and gate drivers within the LTC3350. The power lost due to charging the gates is:

$$P_G \approx (Q_{GTOP} + Q_{GBOT}) \cdot f_{SW} \cdot V_{OUT}$$

where Q_{GTOP} is the top MOSFET gate charge and Q_{GBOT} is the bottom MOSFET gate charge. Whenever possible, utilize MOSFET switches that minimize the total gate charge to limit the internal power dissipation of the LTC3350.

Schottky Diode Selection

Optional Schottky diodes can be placed in parallel with the top and bottom MOSFET switches. These diodes clamp SW during the non-overlap times between conduction of the top and bottom MOSFET switches. This prevents the

APPLICATIONS INFORMATION

body diodes of the MOSFET switches from turning on, storing charge during the non-overlap time and requiring a reverse recovery period that could cost as much as 3% in efficiency at high V_{IN} . One or both diodes can be omitted if the efficiency loss can be tolerated. The diode can be rated for about one-third to one-fifth of the full load current since it is on for only a fraction of the duty cycle. Larger diodes result in additional switching losses due to their larger junction capacitance. In order for the diodes to be effective, the inductance between them and the top and bottom MOSFETs must be as small as possible. This mandates that these components be placed next to each other on the same layer of the PC board.

Top MOSFET Driver Supply (C_B , D_B)

An external bootstrap capacitor, C_B , connected to the BST pin supplies the gate drive voltage for the top MOSFET. Capacitor C_B , in Figure 8, is charged through an external diode, D_B , from DRV_{CC} when the SW pin is low. The value of the bootstrap capacitor, C_B , needs to be 20 times that of the total input capacitance of the top MOSFET.

With the top MOSFET on, the BST voltage is above the system supply rail:

$$V_{BST} = V_{OUT} + V_{DRVCC}$$

The reverse break down of the external diode, D_B , must be greater than $V_{OUT(MAX)} + V_{DRVCC(MAX)}$.

The step-up converter can briefly run nonsynchronously when used in conjunction with the output ideal diode. During this time the BST to SW voltage can pump up to voltages exceeding 5.5V if D_B is a Schottky diode. Fast switching PN diodes are recommended due to their low leakage and junction capacitance. A Schottky diode can be used if the step-up converter runs synchronous throughout backup mode.

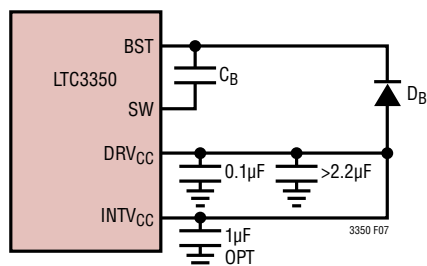

Figure 8. Bootstrap Capacitor/Diode and DRV_{CC} Connections

INTV_{CC}/DRV_{CC} and IC Power Dissipation

The LTC3350 features a low dropout linear regulator (LDO) that supplies power to $INTV_{CC}$ from the V_{OUT} supply. $INTV_{CC}$ powers the gate drivers (when connected to DRV_{CC}) and much of the LTC3350's internal circuitry. The LDO regulates the voltage at the $INTV_{CC}$ pin to 5V. The LDO can supply a maximum current of 50mA and must be bypassed to ground with a minimum of 1µF when not connected to DRV_{CC} . DRV_{CC} should have at least a 2.2µF ceramic or low ESR electrolytic capacitor. No matter what type of bulk capacitor is used on DRV_{CC} , an additional 0.1µF ceramic capacitor placed directly adjacent to the DRV_{CC} pin is highly recommended. Good bypassing is needed to supply the high transient currents required by the MOSFET gate drivers.

High input voltage applications in which large MOSFETs are being driven at high frequencies may cause the maximum junction temperature rating for the LTC3350 to be exceeded. The $INTV_{CC}$ current, which is dominated by the gate charge current, is supplied by the 5V LDO.

Power dissipation for the IC in this case is highest and is approximately equal to $(V_{OUT}) \cdot (I_Q + I_G)$, where I_Q is the non-switching quiescent current of ~4mA and I_G is gate charge current. The junction temperature can be estimated by using the equations given in Note 2 of the Electrical Characteristics. For example, the I_G supplied by the $INTV_{CC}$ LDO is limited to less than 42mA from a 35V supply in the QFN package at a 70°C ambient temperature:

$$T_J = 70^\circ\text{C} + (35\text{V})(4\text{mA} + 42\text{mA})(34^\circ\text{C/W}) = 125^\circ\text{C}$$

To prevent the maximum junction temperature from being exceeded, the $INTV_{CC}$ LDO current must be checked while operating in continuous conduction mode at maximum V_{OUT} .

The power dissipation in the IC is drastically reduced if DRV_{CC} is powered from an external LDO. In this case the power dissipation in the IC is equal to power dissipation due to I_Q and the power dissipated in the gate drivers, $(V_{DRVCC}) \cdot (I_G)$. Assuming the external DRV_{CC} LDO output is 5V and is supplying 42mA to the gate drivers, the junction temperature rises to only 82°C:

$$T_J = 70^\circ\text{C} + [(35\text{V})(4\text{mA}) + (5\text{V})(42\text{mA})](34^\circ\text{C/W}) = 82^\circ\text{C}$$

APPLICATIONS INFORMATION

The external LDO should be powered from V_{OUT} . It must be enabled after the $INTV_{CC}$ LDO has powered up and its output must be less than 5.5V. $INTV_{CC}$ should no longer be tied to DRV_{CC} .

Minimum On-Time Considerations

Minimum on-time, $t_{ON(MIN)}$, is the smallest time duration that the LTC3350 is capable of turning on the top MOSFET in step-down mode. It is determined by internal timing delays and the gate charge required to turn on the top MOSFET. The minimum on-time for the LTC3350 is approximately 85ns. Low duty cycle applications may approach this minimum on-time limit and care should be taken to ensure that:

$$t_{ON(MIN)} < \frac{V_{CAP}}{V_{OUT} \cdot f_{SW}}$$

If the duty cycle falls below what can be accommodated by the minimum on-time, the controller will begin to skip cycles. The charge current and V_{CAP} voltage will continue to be regulated, but the ripple voltage and current will increase.

Ideal Diode MOSFET Selection

An external N-channel MOSFET is required for the input and output ideal diodes. Important parameters for the selection of these MOSFETs are the maximum drain-source voltage, V_{DSS} , gate threshold voltage and on-resistance ($R_{DS(ON)}$).

When the input is grounded, either the supercapacitor stack voltage or the step-up controller's backup voltage is applied across the input ideal diode MOSFET. Therefore, the V_{DSS} of the input ideal diode MOSFET must withstand the maximum voltage on V_{OUT} in backup mode. When the supercapacitors are at 0V, the input voltage is applied across the output ideal diode MOSFET. Therefore, the V_{DSS} of the output ideal diode MOSFET must withstand the highest voltage on V_{IN} .

The gate drive for both ideal diodes is 5V. This allows the use of logic-level threshold N-channel MOSFETs.

As a general rule, select MOSFETs with a low enough $R_{DS(ON)}$ to obtain the desired V_{DS} while operating at full load current. The LTC3350 will regulate the forward voltage drop across the input and output ideal diode MOSFETs to 30mV if $R_{DS(ON)}$ is low enough. The required $R_{DS(ON)}$ can be calculated by dividing 0.030V by the load current in amps.

Achieving forward regulation will minimize power loss and heat dissipation, but it is not a necessity. If a forward voltage drop of more than 30mV is acceptable, then a smaller MOSFET can be used but must be sized compatible with the higher power dissipation. Care should be taken to ensure that the power dissipated is never allowed to rise above the manufacturer's recommended maximum level.

During backup mode, the output ideal diode shuts off when the voltage on $OUTFB$ falls below 1.3V. For high V_{OUT} backup voltages (>8.4V), the output ideal diode will shut off when V_{CAP} is more than a diode drop (~700mV) above the V_{OUT} regulation point (i.e., $OUTFB > 1.2V$). The body diode of the output ideal diode N-channel MOSFET will carry the load current until V_{CAP} drops to within a diode drop of the V_{OUT} regulation voltage at which point the synchronous controller takes over. During this period the power dissipation in the output ideal diode MOSFET increases significantly. Diode conduction time is small compared to the overall backup time but can be significant when discharging very large supercapacitors (>600F). Care should be taken to properly heat sink the MOSFET to limit the temperature rise.

PCB Layout Considerations

When laying out the printed circuit board, the following guidelines should be used to ensure proper operation of the IC. Check the following in your layout:

1. Keep MN1, MN2, D1, D2 and C_{OUT} close together. The high di/dt loop formed by the MOSFETs, Schottky diodes and the V_{OUT} capacitance, shown in Figure 9, should have short, wide traces to minimize high frequency noise and voltage stress from inductive ringing. Surface mount components are preferred to reduce parasitic inductances from component leads.

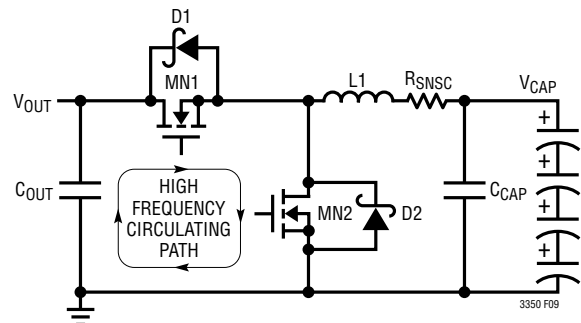

Figure 9. High Speed Switching Path

3350fc

APPLICATIONS INFORMATION

Connect the drain of the top MOSFET and cathode of the top diode directly to the positive terminal of C_{OUT} . Connect the source of the bottom MOSFET and anode of the bottom diode directly to the negative terminal of C_{OUT} . This capacitor provides the AC current to the MOSFETs.

- Ground is referenced to the negative terminal of the V_{CAP} decoupling capacitor in step-down mode and to the negative terminal of the V_{OUT} decoupling capacitor in step-up mode. The negative terminal of C_{OUT} should be as close as possible to the negative terminal of C_{CAP} by placing the capacitors next to each other and away from the switching loop described above. The combined IC SGND pin/PGND paddle and the ground returns of C_{INTVCC} and C_{DRVCC} must return to the combined negative terminal of C_{OUT} and C_{CAP} .
- Effective grounding techniques are critical for successful DC/DC converter layouts. Orient power components such that switching current paths in the ground plane do not cross through the SGND pin and exposed pad on the backside of the LTC3350 IC. Switching path currents can be controlled by orienting the MOSFET switches, Schottky diodes, the inductor, and V_{OUT} and V_{CAP} decoupling capacitors in close proximity to each other.
- Locate V_{CAP} and V_{OUT} dividers near the part and away from switching components. Kelvin the top of resistor dividers to the positive terminals of C_{CAP} and C_{OUT} , respectively. The bottom of the resistive dividers should go back to the SGND pin. The feedback resistor connections should not be run along the high current feeds from the C_{OUT} capacitor.
- Route ICAP and VCAP sense lines together, keep them short. Same with VOUTSP and VOUTSN. Filter components should be placed near the part and not near the sense resistors. Ensure accurate current sensing with Kelvin connections at the sense resistors. See Figure 10.
- The trace from the positive terminal of the input current sense resistor, R_{SNSI} , to the VOUTSP pin carries the part's quiescent and gate drive currents. To maintain accurate measurement of the input current keep this trace short and wide by placing R_{SNSI} near the part.

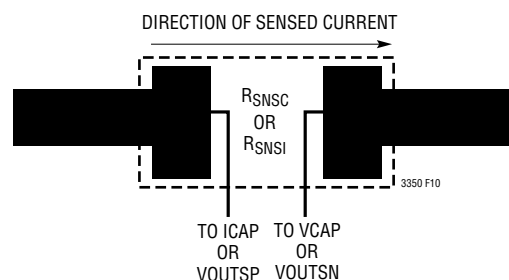

Figure 10. Kelvin Current Sensing

- Locate the DRV_{CC} and BST decoupling capacitors in close proximity to the IC. These capacitors carry the MOSFET drivers' high peak currents. An additional $0.1\mu\text{F}$ ceramic capacitor placed immediately next to the DRV_{CC} pin can help improve noise performance substantially.
- Locate the small-signal components away from high frequency switching nodes (BST, SW, TG, and BG). All of these nodes have very large and fast moving signals and should be kept on the output side of the LTC3350.
- The input ideal diode senses the voltage between V_{IN} and VOUTSP. V_{IN} should be connected near the source of the input ideal diode MOSFET. VOUTSP is used for Kelvin sensing the input current. Place the input current sense resistor, R_{SNSI} , near the input ideal diode MOSFET with a short, wide trace to minimize resistance between the drain of the ideal diode MOSFET and R_{SNSI} .
- The output ideal diode senses the voltage between VOUTSN and VCAP. VCAP is used for Kelvin sensing the charge current. Place the output ideal diode near the charge current sense resistor, R_{SNSC} , with a short, wide trace to minimize resistance between the source of the ideal diode MOSFET and R_{SNSC} .
- The INFET and OUTFET pins for the external ideal diode controllers have extremely limited drive current. Care must be taken to minimize leakage to adjacent PC board traces. 100nA of leakage from these pins will introduce an additional offset to the ideal diodes of approximately 10mV . To minimize leakage, the INFET trace can be guarded on the PC board by surrounding it with VOUT connected metal. Similarly, the OUTFET trace should be guarded by surrounding it with VCAP connected metal.
- The VCC2P5 bypass capacitor should return to ground away from switching and gate drive current paths.

3350fc

REGISTER MAP

REGISTER	SUB ADDR	R/W	BITS	DESCRIPTION	DEFAULT	PAGE
clr_alarms	0x00	R/W	15:0	Clear alarms register	0x0000	33
msk_alarms	0x01	R/W	15:0	Enable/mask alarms register	0x0000	33
msk_mon_status	0x02	R/W	9:0	Enable/mask monitor status alerts	0x0000	34
cap_esr_per	0x04	R/W	15:0	Capacitance/ESR measurement period	0x0000	34
vcapfb_dac	0x05	R/W	3:0	V _{CAP} voltage reference DAC setting	0xF	34
vshunt	0x06	R/W	15:0	Capacitor shunt voltage setting	0x3999	34
cap_uv_lvl	0x07	R/W	15:0	Capacitor undervoltage alarm level	0x0000	34
cap_ov_lvl	0x08	R/W	15:0	Capacitor overvoltage alarm level	0x0000	34
gpi_uv_lvl	0x09	R/W	15:0	GPI undervoltage alarm level	0x0000	34
gpi_ov_lvl	0x0A	R/W	15:0	GPI overvoltage alarm level	0x0000	34
vin_uv_lvl	0x0B	R/W	15:0	V _{IN} undervoltage alarm level	0x0000	35
vin_ov_lvl	0x0C	R/W	15:0	V _{IN} overvoltage alarm level	0x0000	35
vcap_uv_lvl	0x0D	R/W	15:0	V _{CAP} undervoltage alarm level	0x0000	35
vcap_ov_lvl	0x0E	R/W	15:0	V _{CAP} overvoltage alarm level	0x0000	35
vout_uv_lvl	0x0F	R/W	15:0	V _{OUT} undervoltage alarm level	0x0000	35
vout_ov_lvl	0x10	R/W	15:0	V _{OUT} overvoltage alarm level	0x0000	35
iin_oc_lvl	0x11	R/W	15:0	I _{IN} overcurrent alarm level	0x0000	35
ichg_uc_lvl	0x12	R/W	15:0	I _{CHG} undercurrent alarm level	0x0000	35
dtemp_cold_lvl	0x13	R/W	15:0	Die temperature cold alarm level	0x0000	35
dtemp_hot_lvl	0x14	R/W	15:0	Die temperature hot alarm level	0x0000	35
esr_hi_lvl	0x15	R/W	15:0	ESR high alarm level	0x0000	35
cap_lo_lvl	0x16	R/W	15:0	Capacitance low alarm level	0x0000	35
ctl_reg	0x17	R/W	3:0	Control register	0b0000	36
num_caps	0x1A	R	1:0	Number of capacitors configured	–	36
chrg_status	0x1B	R	11:0	Charger status register	–	36
mon_status	0x1C	R	9:0	Monitor status register	–	37
alarm_reg	0x1D	R	15:0	Active alarms register	0x0000	37
meas_cap	0x1E	R	15:0	Measured capacitance value	–	38
meas_esr	0x1F	R	15:0	Measured ESR value	–	38
meas_vcap1	0x20	R	15:0	Measured capacitor one voltage	–	38
meas_vcap2	0x21	R	15:0	Measured capacitor two voltage	–	38
meas_vcap3	0x22	R	15:0	Measured capacitor three voltage	–	38
meas_vcap4	0x23	R	15:0	Measured capacitor four voltage	–	38
meas_gpi	0x24	R	15:0	Measured GPI pin voltage	–	38
meas_vin	0x25	R	15:0	Measured V _{IN} voltage	–	38
meas_vcap	0x26	R	15:0	Measured V _{CAP} voltage	–	38
meas_vout	0x27	R	15:0	Measured V _{OUT} voltage	–	38
meas_iin	0x28	R	15:0	Measured I _{IN} current	–	38
meas_ichg	0x29	R	15:0	Measured I _{CHG} current	–	38
meas_dtemp	0x2A	R	15:0	Measured die temperature	–	38

Registers at sub address 0x03, 0x18, 0x19, 0x2B-0xFF are unused.

REGISTER DESCRIPTIONS

clr_alarms (0x00)

Clear Alarms Register: This register is used to clear alarms caused by exceeding a programmed limit. Writing a one to any bit in this register will cause its respective alarm to be cleared. The one written to this register is automatically cleared when its respective alarm is cleared.

BIT(S)	BIT NAME	DESCRIPTION
0	clr_cap_uv	Clear capacitor undervoltage alarm
1	clr_cap_ov	Clear capacitor overvoltage alarm
2	clr_gpi_uv	Clear GPI undervoltage alarm
3	clr_gpi_ov	Clear GPI overvoltage alarm
4	clr_vin_uv	Clear V_{IN} undervoltage alarm
5	clr_vin_ov	Clear V_{IN} overvoltage alarm
6	clr_vcap_uv	Clear V_{CAP} undervoltage alarm
7	clr_vcap_ov	Clear V_{CAP} overvoltage alarm
8	clr_vout_uv	Clear V_{OUT} undervoltage alarm
9	clr_vout_ov	Clear V_{OUT} overvoltage alarm
10	clr_iin_oc	Clear input overcurrent alarm
11	clr_ichg_uc	Clear charge undercurrent alarm
12	clr_dtemp_cold	Clear die temperature cold alarm
13	clr_dtemp_hot	Clear die temperature hot alarm
14	clr_esr_hi	Clear ESR high alarm
15	clr_cap_lo	Clear capacitance low alarm

msk_alarms (0x01)

Mask Alarms Register: Writing a one to any bit in the Mask Alarms Register enables its respective alarm to trigger an SMBALERT.

BIT(S)	BIT NAME	DESCRIPTION
0	msk_cap_uv	Enable capacitor undervoltage alarm
1	msk_cap_ov	Enable capacitor overvoltage alarm
2	msk_gpi_uv	Enable GPI undervoltage alarm
3	msk_gpi_ov	Enable GPI overvoltage alarm
4	msk_vin_uv	Enable V_{IN} undervoltage alarm
5	msk_vin_ov	Enable V_{IN} overvoltage alarm
6	msk_vcap_uv	Enable V_{CAP} undervoltage alarm
7	msk_vcap_ov	Enable V_{CAP} overvoltage alarm
8	msk_vout_uv	Enable V_{OUT} undervoltage alarm
9	msk_vout_ov	Enable V_{OUT} overvoltage alarm
10	msk_iin_oc	Enable input overcurrent alarm
11	msk_ichg_uc	Enable charge undercurrent alarm
12	msk_dtemp_cold	Enable die temperature cold alarm
13	msk_dtemp_hot	Enable die temperature hot alarm
14	msk_esr_hi	Enable ESR high alarm
15	msk_cap_lo	Enable capacitance low alarm

REGISTER DESCRIPTIONS

msk_mon_status (0x02)

Mask Monitor Status Register: Writing a one to any bit in this register enables a rising edge of its respective bit in the mon_status register to trigger an SMBALERT.

BIT(S)	BIT NAME	DESCRIPTION
0	msk_mon_capesr_active	Set the SMBALERT when there is a rising edge on mon_capesr_active
1	msk_mon_capesr_scheduled	Set the SMBALERT when there is a rising edge on mon_capesr_scheduled
2	msk_mon_capesr_pending	Set the SMBALERT when there is a rising edge on mon_capesr_pending
3	msk_mon_cap_done	Set the SMBALERT when there is a rising edge on mon_cap_done
4	msk_mon_esr_done	Set the SMBALERT when there is a rising edge on mon_esr_done
5	msk_mon_cap_failed	Set the SMBALERT when there is a rising edge on mon_cap_failed
6	msk_mon_esr_failed	Set the SMBALERT when there is a rising edge on mon_esr_failed
7	–	Reserved, write to 0
8	msk_mon_power_failed	Set the SMBALERT when there is a rising edge on mon_power_failed
9	msk_mon_power_returned	Set the SMBALERT when there is a rising edge on mon_power_returned
15:10	–	Reserved, write to 0

cap_esr_per (0x04)

10 seconds per LSB

Capacitance and ESR Measurement Period: This register sets the period of repeated capacitance and ESR measurements. Each LSB represents 10 seconds. Capacitance and ESR measurements will not repeat if this register is zero.

vcapfb_dac (0x05)

CAPFBREF = 37.5mV • vcapfb_dac + 637.5mV

V_{CAP} Regulation Reference: This register is used to program the capacitor voltage feedback loop's reference voltage. Only bits 3:0 are active.

vshunt (0x06)

183.5µV per LSB

Shunt Voltage Register: This register programs the shunt voltage for each capacitor in the stack. The charger will limit current and the active shunts will shunt current to prevent this voltage from being exceeded. As a capacitor voltage nears this level, the charge current will be reduced. This should be programmed higher than the intended final balanced individual capacitor voltage. Setting this register to 0x0000 disables the shunt.

cap_uv_lvl (0x07)

183.5µV per LSB

Capacitor Undervoltage Level: This is an alarm threshold for each individual capacitor voltage in the stack. If enabled, any capacitor voltage falling below this level will trigger an alarm and an SMBALERT.

cap_ov_lvl (0x08)

183.5µV per LSB

Capacitor Overvoltage Level: This is an alarm threshold for each individual capacitor in the stack. If enabled, any capacitor voltage rising above this level will trigger an alarm and an SMBALERT.

gpi_uv_lvl (0x09)

183.5µV per LSB

General Purpose Input Undervoltage Level: This is an alarm threshold for the GPI pin. If enabled, the voltage falling below this level will trigger an alarm and an SMBALERT.

gpi_ov_lvl (0x0A)

183.5µV per LSB

General Purpose Input Overvoltage Level: This is an alarm threshold for the GPI pin. If enabled, the voltage rising above this level will trigger an alarm and an SMBALERT.

REGISTER DESCRIPTIONS

vin_uv_lvl (0x0B)	2.21mV per LSB
V_{IN} Undervoltage Level: This is an alarm threshold for the input voltage. If enabled, the voltage falling below this level will trigger an alarm and an SMBALERT.	
vin_ov_lvl (0x0C)	2.21mV per LSB
V_{IN} Overvoltage Level: This is an alarm threshold for the input voltage. If enabled, the voltage rising above this level will trigger an alarm and an SMBALERT.	
vcap_uv_lvl (0x0D)	1.476mV per LSB
V_{CAP} Undervoltage Level: This is an alarm threshold for the capacitor stack voltage. If enabled, the voltage falling below this level will trigger an alarm and an SMBALERT.	
vcap_ov_lvl (0x0E)	1.476mV per LSB
V_{CAP} Overvoltage Level: This is an alarm threshold for the capacitor stack voltage. If enabled, the voltage rising above this level will trigger an alarm and an SMBALERT.	
vout_uv_lvl (0x0F)	2.21mV per LSB
V_{OUT} Undervoltage Level: This is an alarm threshold for the output voltage. If enabled, the voltage falling below this level will trigger an alarm and an SMBALERT.	
vout_ov_lvl (0x10)	2.21mV per LSB
V_{OUT} Overvoltage Level: This is an alarm threshold for the output voltage. If enabled, the voltage rising above this level will trigger an alarm and an SMBALERT.	
iin_oc_lvl (0x11)	1.983 μ V/ R_{SNSI} per LSB
Input Overcurrent Level: This is an alarm threshold for the input current. If enabled, the current rising above this level will trigger an alarm and an SMBALERT.	
ichg_uc_lvl (0x12)	1.983 μ V/ R_{SNSC} per LSB
Charge Undercurrent Level: This is an alarm threshold for the charge current. If enabled, the current falling below this level will trigger an alarm and an SMBALERT.	
dtemp_cold_lvl (0x13)	Temperature = 0.028 $^{\circ}$ C per LSB – 251.4 $^{\circ}$ C
Die Temperature Cold Level: This is an alarm threshold for the die temperature. If enabled, the die temperature falling below this level will trigger an alarm and an SMBALERT.	
dtemp_hot_lvl (0x14)	Temperature = 0.028 $^{\circ}$ C per LSB – 251.4 $^{\circ}$ C
Die Temperature Hot Level: This is an alarm threshold for the die temperature. If enabled, the die temperature rising above this level will trigger an alarm and an SMBALERT.	
esr_hi_lvl (0x15)	$R_{SNSC}/64$ per LSB
ESR High Level: This is an alarm threshold for the measured stack ESR. If enabled, a measurement of stack ESR exceeding this level will trigger an alarm and an SMBALERT.	
cap_lo_lvl (0x16)	336 μ F • R_T/R_{TST} per LSB
Capacitance Low Level: This is an alarm threshold for the measured stack capacitance. If enabled, if the measured stack capacitance is less than this level it will trigger an alarm and an SMBALERT. When <code>ctl_cap_scale</code> is set to one the constant is $3.36 \cdot R_T/R_{TST}$.	

REGISTER DESCRIPTIONS

ctl_reg (0x17)

Control Register: Several Control Functions are grouped into this register.

BIT(S)	BIT NAME	DESCRIPTION
0	ctl_strt_capesr	Begin a capacitance and ESR measurement when possible; this bit clears itself once a cycle begins.
1	ctl_gpi_buffer_en	A one in this bit location enables the input buffer on the GPI pin. With a zero in this location the GPI pin is measured without the buffer.
2	ctl_stop_capesr	Stops an active capacitance/ESR measurement.
3	ctl_cap_scale	Increases capacitor measurement resolution by 100x, this is used when measuring smaller capacitors.
15:4	–	Reserved

num_caps (0x1A)

Number of Capacitors: This register shows the state of the CAP_SLCT1, CAP_SLCT0 pins. The value read in this register is the number of capacitors programmed minus one.

VALUE	CAPACITORS
0b00	1 Capacitor Selected
0b01	2 Capacitors Selected
0b10	3 Capacitors Selected
0b11	4 Capacitors Selected

chrg_status (0x1B)

Charger Status Register: This register provides real time status information about the state of the charger system. Each bit is active high.

BIT(S)	BIT NAME	DESCRIPTION
0	chrg_stepdown	The synchronous controller is in step-down mode (charging)
1	chrg_stepup	The synchronous controller is in step-up mode (backup)
2	chrg_cv	The charger is in constant voltage mode
3	chrg_uvlo	The charger is in undervoltage lockout
4	chrg_input_ilim	The charger is in input current limit
5	chrg_cappg	The capacitor voltage is above power good threshold
6	chrg_shnt	The capacitor manager is shunting
7	chrg_bal	The capacitor manager is balancing
8	chrg_dis	The charger is temporarily disabled for capacitance measurement
9	chrg_ci	The charger is in constant current mode
10	–	Reserved
11	chrg_pfo	Input voltage is below PFI threshold
15:12	–	Reserved

REGISTER DESCRIPTIONS

mon_status (0x1C)

Monitor Status: This register provides real time status information about the state of the monitoring system. Each bit is active high.

BIT(S)	BIT NAME	DESCRIPTION
0	mon_capesr_active	Capacitance/ESR measurement is in progress
1	mon_capesr_scheduled	Waiting programmed time to begin a capacitance/ESR measurement
2	mon_capesr_pending	Waiting for satisfactory conditions to begin a capacitance/ESR measurement
3	mon_cap_done	Capacitance measurement has completed
4	mon_esr_done	ESR Measurement has completed
5	mon_cap_failed	The last attempted capacitance measurement was unable to complete
6	mon_esr_failed	The last attempted ESR measurement was unable to complete
7	–	Reserved
8	mon_power_failed	This bit is set when V_{IN} falls below the PFI threshold or the charger is unable to charge. It is cleared only when power returns and the charger is able to charge.
9	mon_power_returned	This bit is set when the input is above the PFI threshold and the charger is able to charge. It is cleared only when mon_power_failed is set.
15:10	–	Reserved

alarm_reg (0x1D)

Alarms Register: A one in any bit in the register indicates its respective alarm has triggered. All bits are active high.

BIT(S)	BIT NAME	DESCRIPTION
0	alarm_cap_uv	Capacitor undervoltage alarm
1	alarm_cap_ov	Capacitor overvoltage alarm
2	alarm_gpi_uv	GPI undervoltage alarm
3	alarm_gpi_ov	GPI overvoltage alarm
4	alarm_vin_uv	V_{IN} undervoltage alarm
5	alarm_vin_ov	V_{IN} overvoltage alarm
6	alarm_vcap_uv	V_{CAP} undervoltage alarm
7	alarm_vcap_ov	V_{CAP} overvoltage alarm
8	alarm_vout_uv	V_{OUT} undervoltage alarm
9	alarm_vout_ov	V_{OUT} overvoltage alarm
10	alarm_iin_oc	Input overcurrent alarm
11	alarm_ichg_uc	Charge undercurrent alarm
12	alarm_dtemp_cold	Die temperature cold alarm
13	alarm_dtemp_hot	Die temperature hot alarm
14	alarm_esr_hi	ESR high alarm
15	alarm_cap_lo	Capacitance low alarm

REGISTER DESCRIPTIONS

meas_cap (0x1E)	336 μ F • R _T /R _{TST} per LSB
Measured capacitor stack capacitance value. When <code>ctl_cap_scale</code> is set to one the constant is 3.36 μ F • R _T /R _{TST} .	
meas_esr (0x1F)	R _{NSC} /64 per LSB
Measured capacitor stack equivalent series resistance (ESR) value	
meas_vcap1 (0x20)	183.5 μ V per LSB
Measured voltage between the CAP1 and CAPRTN pins.	
meas_vcap2 (0x21)	183.5 μ V per LSB
Measured voltage between the CAP2 and CAP1 pins.	
meas_vcap3 (0x22)	183.5 μ V per LSB
Measured voltage between the CAP3 and CAP2 pins.	
meas_vcap4 (0x23)	183.5 μ V per LSB
Measured voltage between the CAP4 and CAP3 pins.	
meas_gpi (0x24)	183.5 μ V per LSB
Measurement of GPI pin voltage.	
meas_vin (0x25)	2.21mV per LSB
Measured Input Voltage.	
meas_vcap (0x26)	1.476mV per LSB
Measured Capacitor Stack Voltage.	
meas_vout (0x27)	2.21mV per LSB
Measured Output Voltage.	
meas_iin (0x28)	1.983 μ V/R _{SNSI} per LSB
Measured Input Current.	
meas_ichg (0x29)	1.983 μ V/R _{NSC} per LSB
Measured Charge Current.	
meas_dtemp (0x2A)	Temperature = 0.028°C per LSB – 251.4°C
Measured die temperature.	

TYPICAL APPLICATIONS

Application Circuit 1. 25V to 35V, 6.4A Supercapacitor Charger with 2A Input Current Limit and 28V, 50W Backup Mode

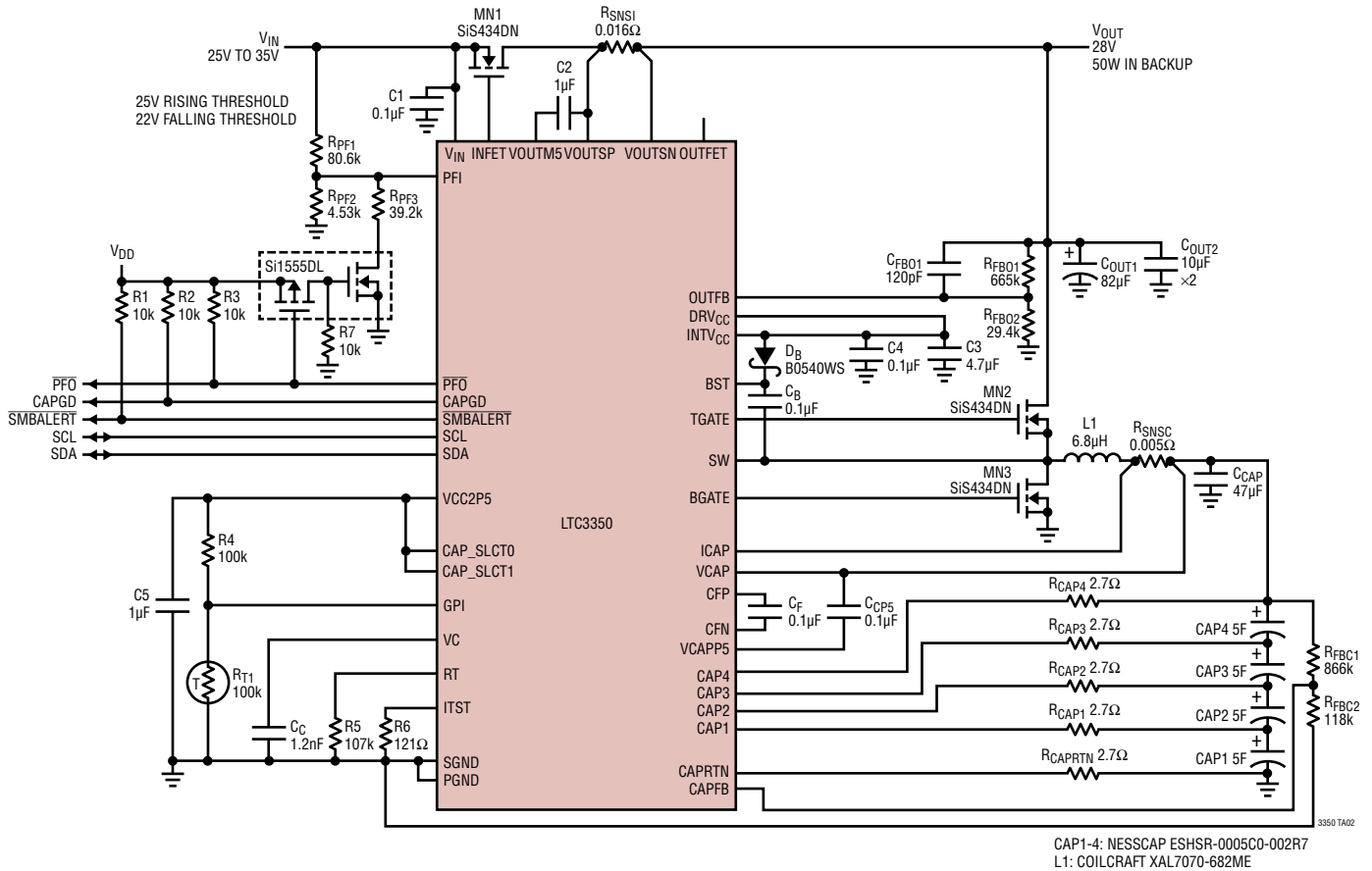

TYPICAL APPLICATIONS

Application Circuit 4. 11V to 35V, 4A Supercapacitor Charger with 2A Input Current Limit and 10V, 1A Backup Mode

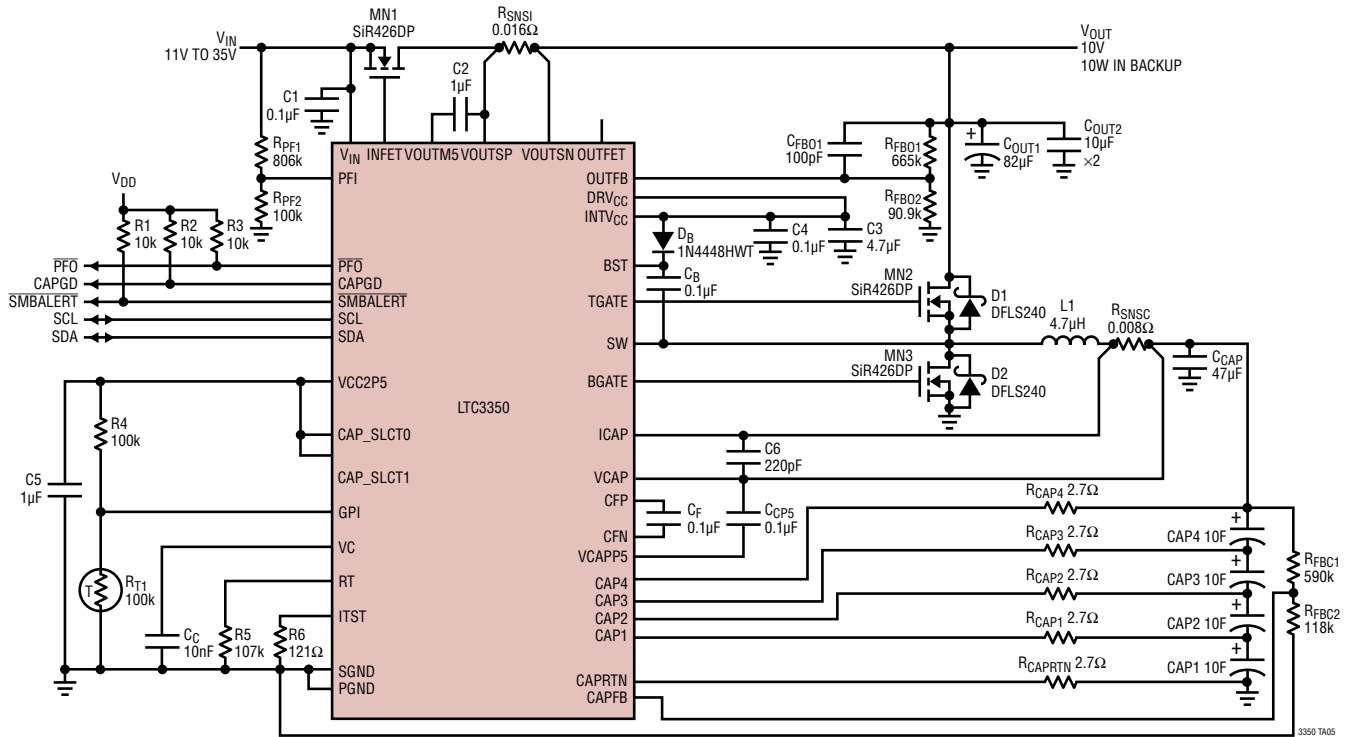

CAP1-4: NESSCAP ESHSR-0010C0-002R7
 L1: VISHAY IHLP5050FDER47M01

Application Circuit 5. 11V to 20V, 4A Supercapacitor Charger with 2A Input Current Limit and 5V, 2A Backup Mode

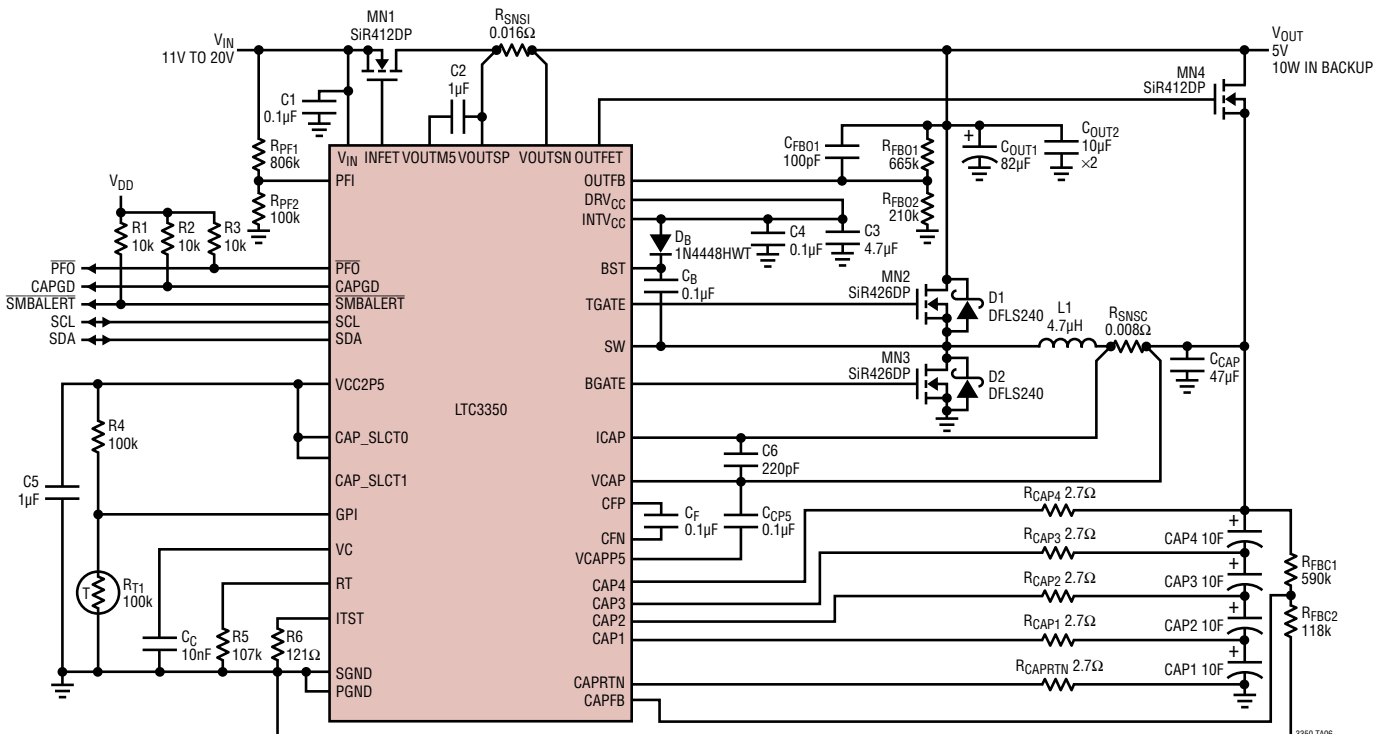

CAP1-4: NESSCAP ESHSR-0010C0-002R7
 L1: VISHAY IHLP5050FDER47M01

TYPICAL APPLICATIONS

Application Circuit 6. 11V to 15V, 2.3A Zeta-SEPIC High Voltage Capacitor Charger with 2A Input Current Limit and 10V, 25W Backup Mode

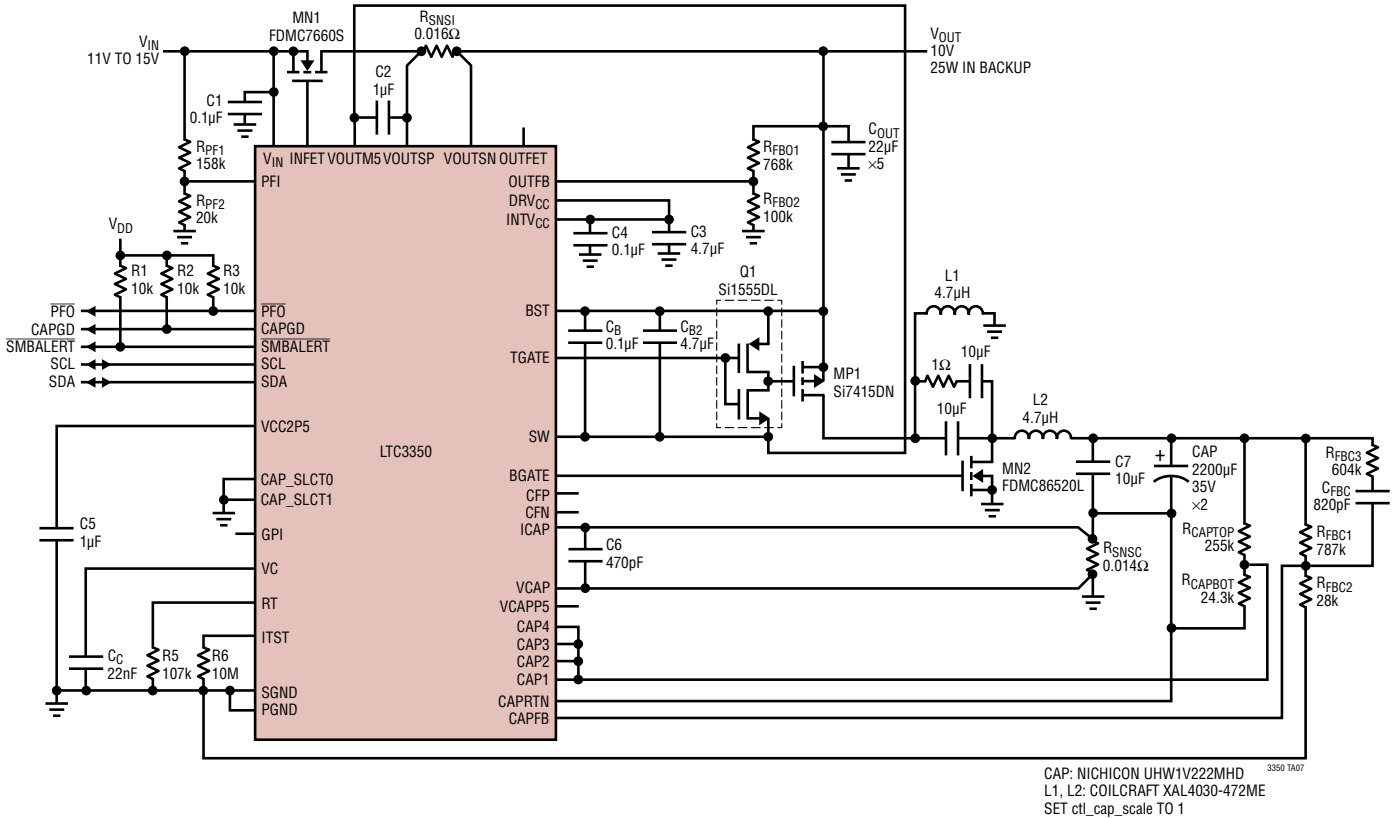

In a Zeta-SEPIC application there are several differences in the monitoring features due to differences in how the LTC3350 is configured. The capacitor voltage is measured differently, it is no longer measured in the meas_vcap register, but in the meas_vcap1 register. The scale factor for meas_vcap1 must be adjusted for the resistor divider connected to the CAP1 pin. Also in this configuration the precision current load (ITST) for the capacitance test cannot be used. The load on the capacitors are the external dividers only. A capacitance measurement may still be done. The results in the meas_cap_register will have an LSB in Farads of:

$$C_{\text{LSB}} = \frac{-5.6 \cdot 10^{-7}}{\ln \left[1 - \left(\frac{0.2}{V_{\text{CAP}}} \right) \left(1 + \frac{R_{\text{CAPTOP}}}{R_{\text{CAPBOT}}} \right) \right]} \frac{R_T}{R_L}$$

where R_L is the total resistance to ground in parallel with the capacitor, R_{CAPTOP} is the top divider resistor from the capacitor to CAP1 and R_{CAPBOT} is the bottom divider resistor from CAP1 to ground. The above equation is for when the `ctl_cap_scale` bit is set to one. ESR measurements may be possible with large capacitors with larger ESR's. However, the accuracy of the ESR measurement in this application is significantly reduced. The ESR measurement in the `meas_esr` register must be scaled up by the resistor divider ratio. The voltage at the CAP1 pin should be kept below the V_{SHUNT} setting.

The voltage at the CAP1 pin will be above the default shunt value (2.7V) when V_{CAP} is greater than 31V. In order to continue charging to 35V, the shunts should be disabled by setting `vshunt` to zero (0x0000).

TYPICAL APPLICATIONS

Application Circuit 7. 4.8V to 12V, 10A Supercapacitor Charger with 6.4A Input Current Limit and 5V, 30W Backup Mode

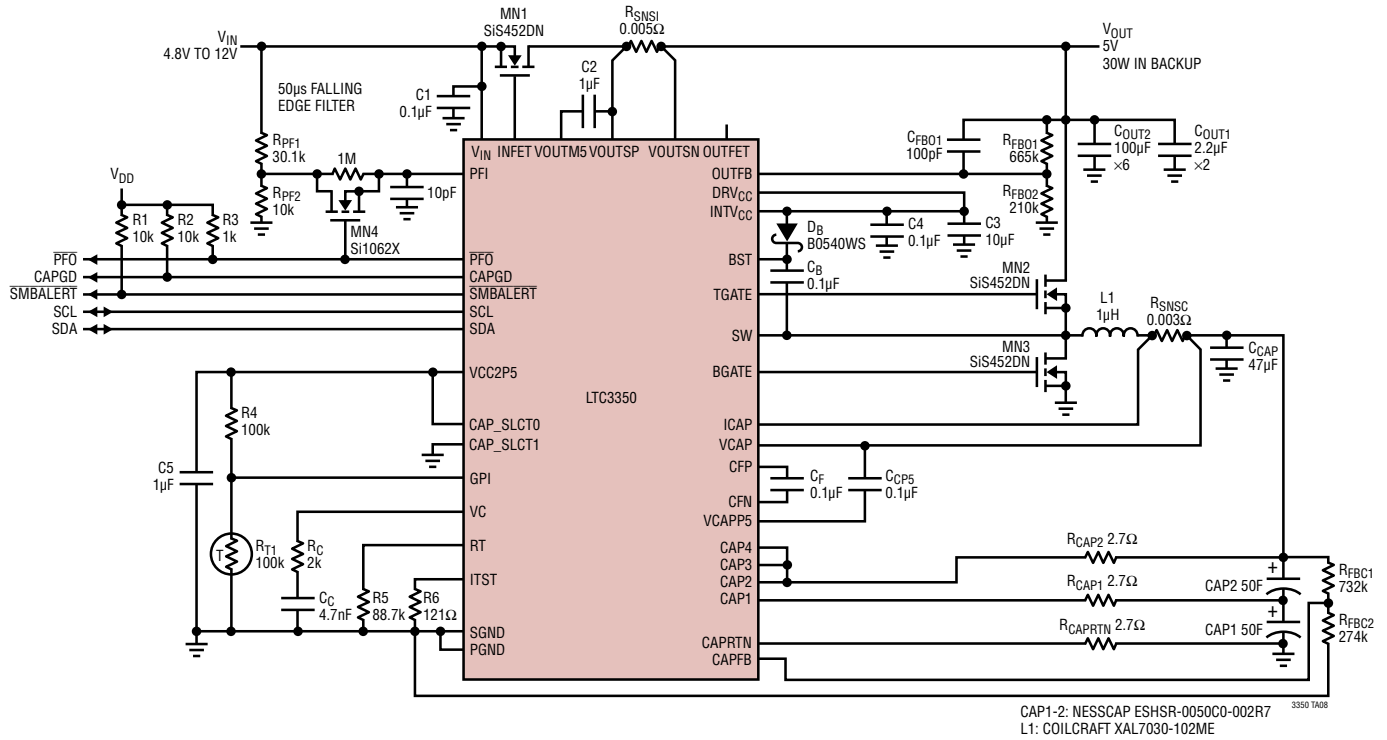

PACKAGE DESCRIPTION

Please refer to <http://www.linear.com/designtools/packaging/> for the most recent package drawings.

UHF Package
38-Lead Plastic QFN (5mm × 7mm)
 (Reference LTC DWG # 05-08-1701 Rev C)

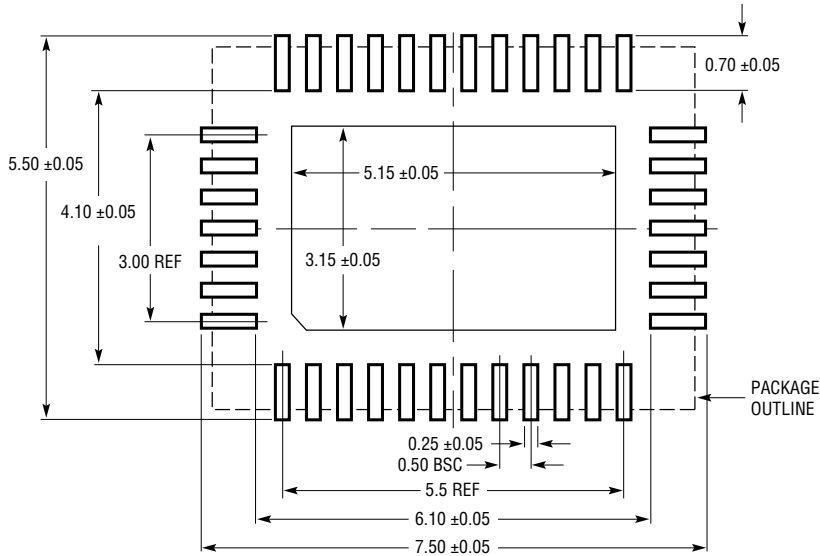

RECOMMENDED SOLDER PAD LAYOUT
 APPLY SOLDER MASK TO AREAS THAT ARE NOT SOLDERED

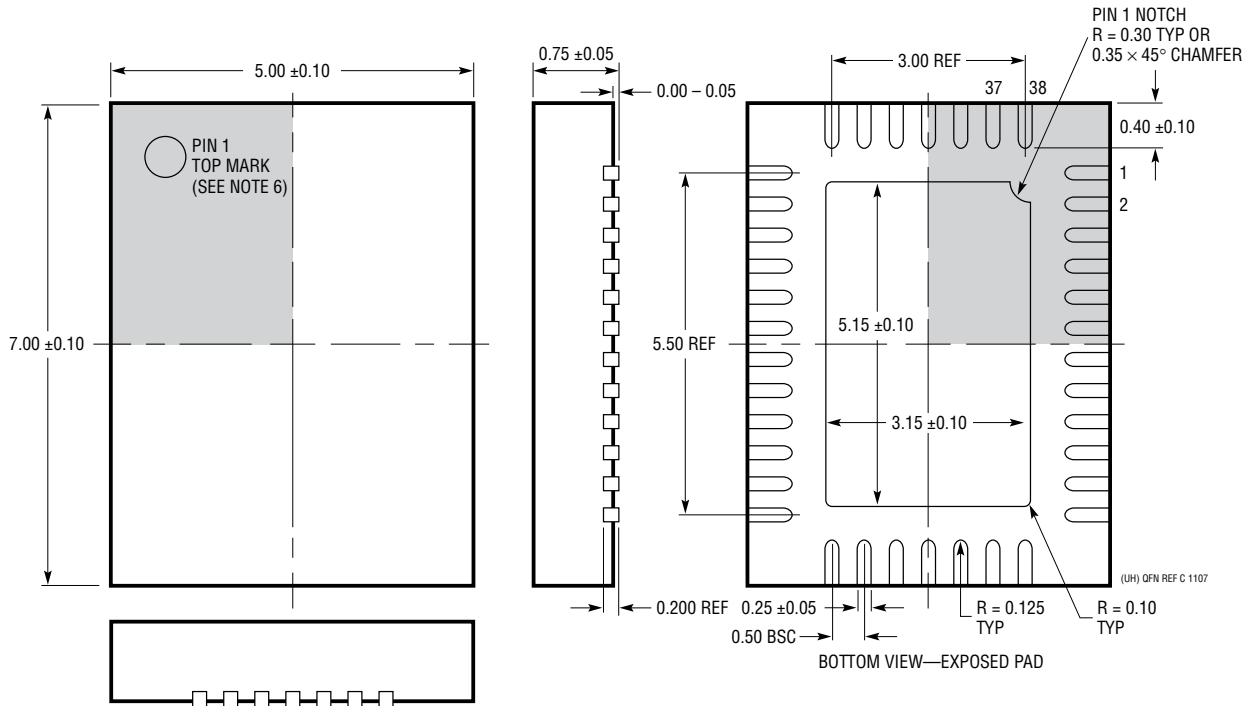

NOTE:

1. DRAWING CONFORMS TO JEDEC PACKAGE OUTLINE M0-220 VARIATION WHKD
2. DRAWING NOT TO SCALE
3. ALL DIMENSIONS ARE IN MILLIMETERS
4. DIMENSIONS OF EXPOSED PAD ON BOTTOM OF PACKAGE DO NOT INCLUDE MOLD FLASH. MOLD FLASH, IF PRESENT, SHALL NOT EXCEED 0.20mm ON ANY SIDE
5. EXPOSED PAD SHALL BE SOLDER PLATED
6. SHADED AREA IS ONLY A REFERENCE FOR PIN 1 LOCATION ON THE TOP AND BOTTOM OF PACKAGE

REVISION HISTORY

REV	DATE	DESCRIPTION	PAGE NUMBER
A	09/14	Modified I_{RMS} equations in C_{OUT} and C_{CAP} Capacitance section	27
		Changed 5V to 6V in back-up mode under the Power MOSFET Selection section	28
		Changed V_{CAP} voltage reference DAC setting	32
		Modified Application Circuit	42
B	01/15	Remove V_{CMI} Common Mode Range from Electrical Characteristics	4
		Remove Conditions on I_{PF0} Falling and Rising	5
		Change Analog-to-Digital Converter section	18
		Change range in the General Purpose Input section to 0V to 5V	20
		Change MN1 to MP1 just below Figure 6	23
		Change M1, M2 to MN1, MN2 in the PCB Layout Considerations section	30
		Increase page numbers to all entries on the Register Map	32
		For meas_vcap change μV to mV	38
Change name to Application Circuit 6	42		
C	08/15	Modified Order Information Table for temperature grade identified by label on shipping container	3
		Modified Input Overvoltage Protection Section	17
		Add sentence at the end of the first paragraph	18
		Add three sentences to the end of the Capacitance and ESR Measurements section	19
		Replace sentence in the Limit Checking and Alarms section	20
		Modified Figure 3	22
		Add new supplier to Table 2, Supercapacitor Suppliers	26
		Add Note 12 in the PCB Considerations Layout section	31
		Change reference from R_{TST}/R_T to R_T/R_{TST} on cap_lo_lvl description	35
		Change reference from R_{TST}/R_T to R_T/R_{TST} on meas_cap description	38
Change value of R_{CAPBOT} to 24.3k from 20k. Also add two sentences to the end of the text	42		

TYPICAL APPLICATION

12V PCIe Backup Controller

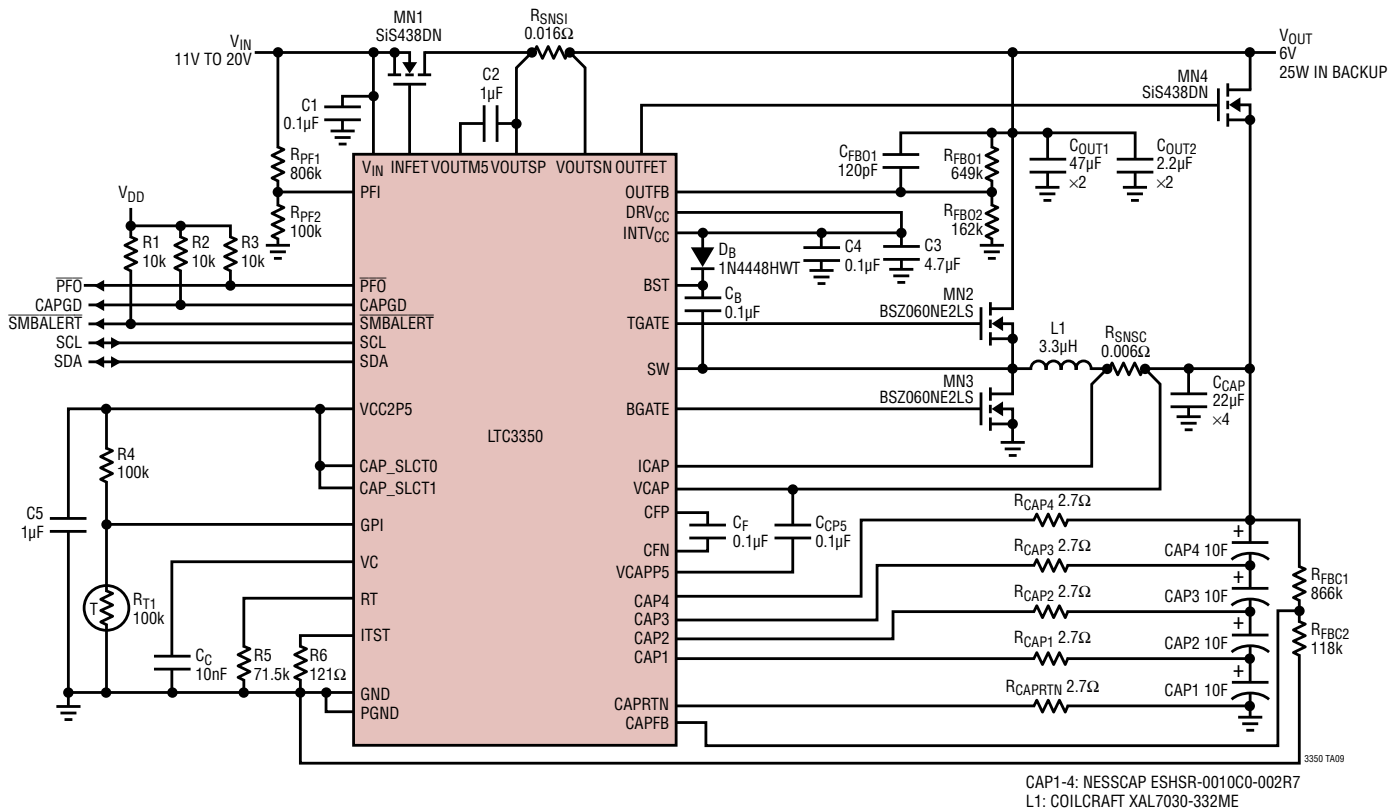

RELATED PARTS

PART NUMBER	DESCRIPTION	COMMENTS
Power Management		
LTC3128	3A Monolithic Buck-Boost Supercapacitor Charger and Balancer with Accurate Input Current Limit	±2% Accurate Average Input Current Limit Programmable to 3A, Active Charge Balancing, Charges 1 or 2 Capacitors, V_{IN} Range: 1.73V to 5.5V, V_{OUT} Range: 1.8V to 5.5V, 20-Lead (4mm × 5mm × 0.75mm) QFN and 24-Lead TSSOP Packages
LTC3226	2-Cell Supercapacitor Charger with Backup PowerPath Controller	1x/2x Multimode Charge Pump Supercapacitor Charger, Automatic Cell Balancing, PowerPath, 2A LDO Backup Supply, Automatic Main/Backup Switchover, 2.5V to 5.5V, 16-Lead 3mm × 3mm QFN Package
LTC3355	20V, 1A Buck DC/DC with Integrated SCAP Charger and Backup Regulator	V_{IN} : 3V to 20V, V_{OUT} : 2.7V to 5V, 1A Main Buck Regulator, 5A Boost Backup Regulator Powered from Single Supercapacitor, Overvoltage Protection, 20-Lead 4mm × 4mm QFN Package.
LTC3625	1A High Efficiency 2-Cell Supercapacitor Charger with Automatic Cell Balancing	High Efficiency Step-Up/Step-Down Charging of Two Series Supercapacitors. Automatic Cell Balancing. Programmable Charging Current to 500mA (Single Inductor), 1A (Dual Inductor). 12-Lead 3mm × 4mm DFN Package
LTC4110	Battery Backup System Manager	Complete Backup Battery Manager for Li-Ion/Polymer, Lead Acid, NiMH/ NiCd Batteries and Supercapacitors. Input Supply Range: 4.5V to 19V, Programmable Charge Current Up to 3A, 38-Lead 5mm × 7mm QFN Package.
LTC4425	Linear SuperCap Charger with Current-Limited Ideal Diode and V/I Monitor	Constant-Current/Constant-Voltage Linear Charger for 2-Cell Series Supercapacitor Stack. V_{IN} : Li-Ion/Polymer Battery, a USB Port, or a 2.7V to 5.5V Current-Limited Supply. 2A Charge Current, Automatic Cell Balancing, Shutdown Current <2µA. 12-Pin 3mm × 3mm DFN or 12-Lead MSOP Package

3350fc

Looking for pricing, stock, or lifecycle information?

Click below to explore more details on WIN SOURCE:

 [View LTC3350EUHF#PBF on WIN SOURCE](#)

 [Linear Technology](#) Information

Optimize Your Supply Chain with WIN SOURCE Solutions

-  Global Sourcing Solution
-  Obsolete Management
-  Cost Control Management
-  Shortage Management
-  Alternative Solution
-  Excess Inventory Management