



**THE DATASHEET OF  
DP83867IRPAPT**



# DP83867IR/CR Robust, High Immunity 10/100/1000 Ethernet Physical Layer Transceiver

## 1 Features

- Ultra Low RGMII Latency TX < 90ns, RX < 290ns
- Low Power consumption 457 mW
- Exceeds 8000 V IEC 61000-4-2 ESD Protection
- Meets EN55011 Class B Emission Standards
- 16 Programmable RGMII Delay Modes on RX/TX
- Integrated MDI Termination Resistors
- Programmable MII/GMII/RGMII Termination Impedance
- WoL (Wake-on-LAN) Packet Detection
- 25-MHz or 125-MHz Synchronized Clock Output
- IEEE 1588 Time Stamp Support
- RJ45 Mirror Mode
- Fully Compatible to IEEE 802.3 10BASE-Te, 100BASE-TX, and 1000BASE-T Specification
- Cable Diagnostics
- MII, GMII and RGMII MAC Interface Options
- Configurable I/O Voltage (3.3 V, 2.5 V, 1.8 V)
- Fast Link up / Link Drop Modes
- JTAG Support

## 2 Applications

- Motor and Motion Control
- Industrial Factory Automation
- Industrial Embedded Computing
- Wired and Wireless Communications Infrastructure
- Test and Measurement
- Consumer Electronics

## 3 Description

The DP83867 device is a robust, low power, fully featured Physical Layer transceiver with integrated PMD sublayers to support 10BASE-Te, 100BASE-TX and 1000BASE-T Ethernet protocols. Optimized for ESD protection, the DP83867 exceeds 8-kV IEC 61000-4-2 (direct contact).

The DP83867 is designed for easy implementation of 10/100/1000 Mbps Ethernet LANs. It interfaces directly to twisted pair media via an external transformer. This device interfaces directly to the MAC layer through the IEEE 802.3 Standard Media Independent Interface (MII), the IEEE 802.3 Gigabit Media Independent Interface (GMII) or Reduced GMII (RGMII). The QFP package supports MII/GMII/RGMII whereas the QFN package supports RGMII.

The DP83867 provides precision clock synchronization, including a synchronous Ethernet clock output. It has low latency and provides IEEE 1588 Start of Frame Detection.

The DP83867 consumes only 490mW (PAP) and 457mW (RGZ) under full operating power. Wake on LAN can be used to lower system power consumption.

### Device Information<sup>(1)</sup>

PART NUMBER	TEMPERATURE	PACKAGE	BODY SIZE (NOM)
DP83867IRPAP	-40°C to +85°C	QFP (64)	10 mm x 10 mm
DP83867IRRGZ	-40°C to +85°C	QFN (48)	7 mm x 7 mm
DP83867CRRGZ	0°C to +70°C	QFN (48)	7 mm x 7 mm

(1) For all available packages, see the orderable addendum at the end of the data sheet.

## System Diagram

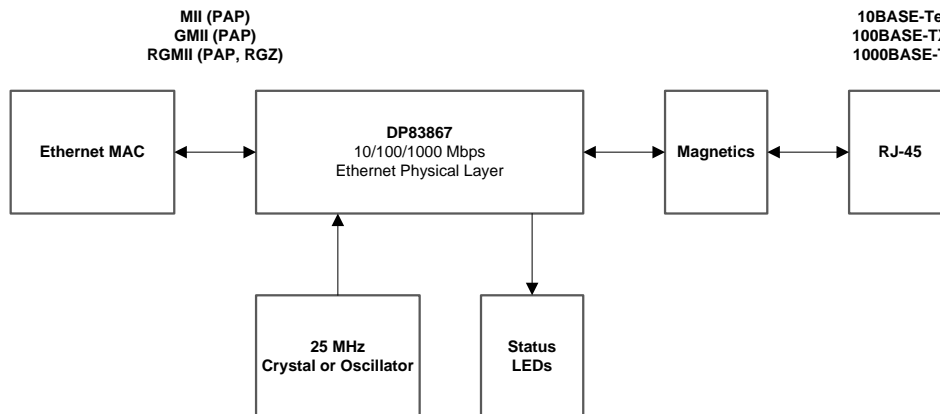

## Table of Contents

<b>1</b>	<b>Features</b> .....	<b>1</b>	<b>8</b>	<b>Detailed Description</b> .....	<b>24</b>
<b>2</b>	<b>Applications</b> .....	<b>1</b>	8.1	Overview .....	24
<b>3</b>	<b>Description</b> .....	<b>1</b>	8.2	Functional Block Diagram .....	25
<b>4</b>	<b>Revision History</b> .....	<b>3</b>	8.3	Feature Description .....	27
<b>5</b>	<b>Device Comparison</b> .....	<b>7</b>	8.4	Device Functional Modes .....	30
<b>6</b>	<b>Pin Configuration and Functions</b> .....	<b>7</b>	8.5	Programming .....	45
6.1	Unused Pins .....	12	8.6	Register Maps .....	54
<b>7</b>	<b>Specifications</b> .....	<b>13</b>	<b>9</b>	<b>Application and Implementation</b> .....	<b>109</b>
7.1	Absolute Maximum Ratings .....	13	9.1	Application Information .....	109
7.2	ESD Ratings .....	13	9.2	Typical Application .....	109
7.3	Recommended Operating Conditions .....	13	<b>10</b>	<b>Power Supply Recommendations</b> .....	<b>113</b>
7.4	Thermal Information .....	14	<b>11</b>	<b>Layout</b> .....	<b>115</b>
7.5	Electrical Characteristics .....	14	11.1	Layout Guidelines .....	115
7.6	Power-Up Timing .....	15	11.2	Layout Example .....	118
7.7	Reset Timing .....	16	<b>12</b>	<b>Device and Documentation Support</b> .....	<b>119</b>
7.8	MII Serial Management Timing .....	16	12.1	Documentation Support .....	119
7.9	RGMII Timing .....	16	12.2	Related Links .....	119
7.10	GMII Transmit Timing .....	17	12.3	Receiving Notification of Documentation Updates .....	119
7.11	GMII Receive Timing .....	17	12.4	Community Resources .....	119
7.12	100-Mbps MII Transmit Timing .....	17	12.5	Trademarks .....	119
7.13	100-Mbps MII Receive Timing .....	17	12.6	Electrostatic Discharge Caution .....	119
7.14	10-Mbps MII Transmit Timing .....	18	12.7	Glossary .....	119
7.15	10-Mbps MII Receive Timing .....	18	<b>13</b>	<b>Mechanical, Packaging, and Orderable Information</b> .....	<b>120</b>
7.16	DP83867IR/CR Start of Frame Detection Timing .....	18			
7.17	Typical Characteristics .....	23			

## 4 Revision History

NOTE: Page numbers for previous revisions may differ from page numbers in the current version.

Changes from Revision D (July 2016) to Revision E	Page
• Changed $\overline{\text{INT}}$ / $\overline{\text{PWN}}$ description in <i>Pin Functions</i> table .....	11
• Added <i>DP83867IR/CR Start of Frame Detection Timing</i> .....	18
• Added section <i>SFD Latency Variation and Determinism</i> .....	29
• Added a statement to 4-Level Strap Pins table note.....	48
• Changed <a href="#">Table 8</a> .....	48
• Changed <a href="#">Table 9</a> .....	48
• Changed bit 8:7 from RO to RW in <i>Configuration Register 4 (CFG4)</i> .....	83
• Added <i>Skew FIFO Status (SKEW_FIFO)</i> register.....	85
• Added note to STRAP_CLK_OUT_DIS bit in <a href="#">Table 44</a> register.....	86
• Added <i>Sync FIFO Control (SYNC_FIFO_CTRL)</i> register .....	88
• Clarified <a href="#">Figure 30</a> .....	110

Changes from Revision C (November 2015) to Revision D	Page
• Added '(Straps Required)' to RX_DV/RX_CTRL pin in <i>Pin Functions</i> table .....	10
• Changed '1nF' to '1 $\mu$ F' for VDD1P1 and VDD1P0 pin in <i>Pin Functions</i> table.....	12
• Added storage temperature to <i>Absolute Maximum Ratings</i> .....	13
• Added Operating Junction Temperature to <i>Recommended Operating Conditions</i> .....	13
• Changed parameter symbol from VIH to V <sub>IH</sub> in <i>Electrical Characteristics</i> .....	14
• Added MDC toggling clarification to <i>Reset Timing</i> <sup>(2)</sup> .....	16
• Changed target strap voltage thresholds in <a href="#">Table 4</a> .....	45
• Changed 'SPEED_SEL1' to 'ANEG_SEL1' in <a href="#">Table 5</a> .....	46
• Added '(Straps Required)' to RX_DV/RX_CTRL in <a href="#">Table 5</a> .....	46
• Changed 'SPEED_SEL0' to 'ANEG_SEL' in <a href="#">Table 5</a> .....	47
• Changed 'SPEED_SEL0' to 'ANEG_SEL0' in <a href="#">Table 5</a> .....	47
• Changed table name from 'PAP Speed Select Strap Details' to <a href="#">Table 6</a> .....	48
• Changed 'SPEED_SEL0' and 'SPEED_SEL' to 'ANEG_SEL0' and 'ANEG_SEL1' in <a href="#">Table 6</a> .....	48
• Changed table name from 'RGZ Speed Select Strap Details' to <a href="#">Table 7</a> .....	48
• Changed 'SPEED_SEL' to 'ANEG_SEL' in <a href="#">Table 7</a> .....	48
• Changed Default state of from 'Strap' to '0' for bit 13 in <a href="#">Table 10</a> .....	54
• Changed Default state of from 'Strap' to '1' for bit 6 in <a href="#">Table 10</a> .....	55
• Changed bit 9 name from 100BASE-T FULL DUPLEX to 1000BASE-T FULL DUPLEX in <a href="#">Table 19</a> .....	64
• Changed bit 9 descriptions from half duplex to full duplex in <a href="#">Table 19</a> .....	64
• Changed 'Interrupt Status and Event Control Register (ISR)' to 'MII Interrupt Control Register (MICR)' in <i>MII Interrupt Control Register (MICR)</i> .....	70
• Changed Register definition to move a statement from <i>Interrupt Status Register (ISR)</i> to <i>MII Interrupt Control Register (MICR)</i> .....	70
• Changed default of bit 9 from '1' to '0' in <i>Configuration Register 2 (CFG2)</i> , Address 0x0014.....	74
• Changed default of bits 5:0 from '0' to '0 0111' in <a href="#">Table 28</a> .....	74
• Added <i>Fast Link Drop Configuration Register (FLD_CFG)</i> register .....	83
• Changed Name of Bits 6:5 from 'STRAP_SPEED_SEL' to 'STRAP_ANEG_SEL' in <a href="#">Table 44</a> .....	86
• Changed Name of Bit 6 from 'RESERVED' to 'RESERVED (RGZ)' in <a href="#">Table 44</a> .....	86
• Changed Name of Bit 5 from 'STRAP_SPEED_SEL (PAP)' to 'STRAP_SPEED_SEL (RGZ)' in <a href="#">Table 44</a> .....	86
• Changed name of Bit 6:4 from 'RESERVED' to 'RESERVED (PAP)' in <a href="#">Table 45</a> .....	87

• Added description for 'STRAP_RGMII_CLK_SKEW_TX (RGZ)' in <a href="#">Table 45</a> .....	87
• Changed name of Bit 2:0 from 'RESERVED' to 'RESERVED (PAP)' in <a href="#">Table 45</a> .....	87
• Added description for 'STRAP_RGMII_CLK_SKEW_RX (RGZ)' in <a href="#">Table 45</a> .....	87
• Changed default value of bit 4:0 from '10000' to 'TRIM' in <a href="#">I/O Configuration (IO_MUX_CFG)</a> .....	97
• Changed description for IO_IMPEDANCE_CTRL bits in <a href="#">I/O Configuration (IO_MUX_CFG)</a> .....	97
• Changed <a href="#">Power Supply Recommendations</a> section .....	113
• Added "The 2.5-V VDDA2P5 can come up with or after the 1.8-V VDDA1P8 but not before it" to <a href="#">Power Supply Recommendations</a> .....	115
• Added <a href="#">Figure 35</a> .....	115
• Added <a href="#">Table 126</a> .....	115
• Added note regarding 1.8-V supply sequence if no load exists on 2.5-V supply in <a href="#">Layout</a> .....	115

**Changes from Revision B (August 2015) to Revision C**
**Page**

• Changed the title to add DP83867IRRGZ/CRRGZ in the datasheet. ....	1
• Added part numbers .....	1
• Changed latency bullet point in <a href="#">Features</a> for better description of the Low Latency Feature. ....	1
• Changed Power consumption number in <a href="#">Features</a> section.....	1
• Added Radiated Emissions performance to <a href="#">Features</a> .....	1
• Added MDI Termination Resistor in <a href="#">Features</a> .....	1
• Added Programmable MAC Interface Impedance in .....	1
• Added 'RJ45 Mirror Mode' to <a href="#">Features</a> .....	1
• Added compatibility to <a href="#">Features</a> .....	1
• Added MAC interface information in <a href="#">Description</a> .....	1
• Added Package information for the new devices in the <a href="#">Device Information</a> table .....	1
• Added <a href="#">Device Comparison</a> Table.....	7
• Changed <a href="#">Pin Functions</a> table to add information about new RGZ devices.....	9
• Added information about pull-up pull-down resistors in the table note of the <a href="#">Pin Functions</a> table .....	9
• Changed bypass capacitor information for power pins in <a href="#">Pin Functions</a> table.....	12
• Added <a href="#">Unused Pins</a> section .....	12
• Added <a href="#">Absolute Maximum Ratings</a> table.....	13
• Added ESD information about new RGZ devices in <a href="#">ESD Ratings</a> .....	13
• Added VDD1P0 information in <a href="#">Recommended Operating Conditions</a> .....	13
• Added temperature information about RGZ devices in <a href="#">Recommended Operating Conditions</a> .....	13
• Added thermal information for RGZ Devices in <a href="#">Thermal Information</a> .....	14
• Added PMD output voltage data for new RGZ devices in <a href="#">Electrical Characteristics</a> .....	14
• Added RGMII TX and RX Latency values in <a href="#">RGMII Timing</a> <sup>(4)</sup> .....	16
• Added FBD for new RGZ devices in <a href="#">Functional Block Diagram</a> .....	26
• Added "Magic Packet should be byte aligned" in <a href="#">Magic Packet Structure</a> section. ....	27
• Changed "Auto-MDIX is independent of Auto-Negotiation" to "For 10/100, Auto-MDIX is independent of Auto-Negotiation" in <a href="#">Auto-MDIX Resolution</a> .....	39
• Added <a href="#">Loopback Availability</a> table.....	39
• Changed description for <a href="#">Analog Loopback</a> .....	40
• Added description for <a href="#">External Loopback</a> .....	40
• Changed "improperly-terminated cables with ±1m accuracy" to "improperly-terminated cables, and crossed pairs wires with ±1m accuracy" in <a href="#">TDR</a> .....	41
• Added "0.5ms in 1000M mode" in <a href="#">Fast Link Drop</a> section .....	42
• Deleted mention of FLD_CFG and FLD_THR_CFG from <a href="#">Fast Link Drop</a> .....	42

• Changed <a href="#">Mirror Mode</a> Configuration table.....	43
• Added Added internal resistor to the diagram in <a href="#">Figure 24</a> .....	45
• Added Target voltage range in <a href="#">Table 4</a> .....	45
• Added strapping information for RGZ devices in <a href="#">Table 5</a> .....	46
• Changed incorrect pin number for LED_1 and LED_0 in <a href="#">Table 5</a> table.....	47
• Added RGMII TX and RX Skew Strap information to <a href="#">Table 5</a> .....	47
• Added <a href="#">Table 7</a> .....	48
• Added <a href="#">Table 8</a> .....	48
• Added <a href="#">Table 9</a> .....	48
• Added information regarding address configuration of RGZ devices to <a href="#">PHY Address Configuration</a> .....	50
• Added <a href="#">Power Saving Modes</a> section.....	52
• Changed Bit 13 description in <a href="#">Register 0x14</a> .....	74
• Deleted "in Robust Auto MDI-X modes" in bit 15 description of <a href="#">Configuration Register 3 (CFG3)</a> .....	80
• Added "ms" to timer values in bit 13:12 in <a href="#">Configuration Register 3 (CFG3)</a> .....	80
• Deleted Registers FLD_CFG and FLD_THR_CFG from Datasheet.....	82
• Changed description for bit 11 in <a href="#">100BASE-TX Configuration (100CR)</a> .....	85
• Added information in bit 10:7 description for <a href="#">100BASE-TX Configuration (100CR)</a> .....	85
• Added comment about RGZ devices in <a href="#">GPIO Mux Control Register 1 (GPIO_MUX_CTRL1)</a> .....	98
• Added comment about RGZ devices in <a href="#">GPIO Mux Control Register 2 (GPIO_MUX_CTRL2)</a> .....	100
• Added <a href="#">GPIO_MUX_CTRL</a> register for RGZ devices.....	101
• Added TDR registers .....	102
• Added footnote about voltage level for RGZ devices in <a href="#">Figure 33</a> .....	113
• Added Comment for VDDA1P8 pins in <a href="#">Figure 33</a> . .....	113
• Added footnote about Voltage level for RGZ devices in <a href="#">Figure 34</a> .....	114
• Added power down supply sequence sentence in <a href="#">Power Supply Recommendations</a> .....	115
• Changed <a href="#">Layout</a> section.....	115

**Changes from Revision A (June 2015) to Revision B**
**Page**

• Added "Power consumption as low as 490 mW" to the <a href="#">Features</a> list .....	1
• Changed <a href="#">Description</a> text From: "The DP83867 consumes only 565 mW" To: "The DP83867 consumes only 490 mW" ...	1
• Changed Pin RBIAS Description From: "A 10 kΩ +/-1% resistor" To: "A 11 kΩ ±1% resistor". .....	12
• Changed Power consumption, 2 supplies TYP value From 565 mW To 530 mW in the <a href="#">Electrical Characteristics</a> .....	15
• Changed Power consumption, optional 3rd supply TYP value From 545 mW To 490 mW in the <a href="#">Electrical Characteristics</a> .....	15
• Changed Register address: From: "BICSR1 register (0x0039)" To: "BICSR2 register (0x0072)", and changed From: "read from the BICSR register (0x0016h)" To: "read from the STS2 register (0x0017h)" in the <a href="#">BIST Configuration</a> .....	41
• Changed section <a href="#">BIST Control and Status Register 1 (BICSR1)</a> and <a href="#">Table 46</a> From: Address 0x0039 To: Address 0x0071 .....	87
• Changed section <a href="#">BIST Control and Status Register 2 (BICSR2)</a> and <a href="#">Table 47</a> From: Address 0x003A To: Address 0x0072 .....	87

<b>Changes from Original (February 2015) to Revision A</b>	<b>Page</b>
• Changed the document title From: "Robust, Low Power" To: "Robust, High Immunity" .....	1
• Changed the <i>Features</i> listed under "Highlights" .....	1
• Changed the <i>Applications</i> list .....	1
• Changed the <i>Description</i> text and layout .....	1
• Added $T_F$ fall time = 0.75 ns (Max) in <i>RGMI</i> Timing <sup>(4)</sup> .....	16
• Added T4, MDI to GMII Latency = 264 ns (NOM) to <i>GMII Receive Timing</i> <sup>(6)</sup> .....	17
• Changed the title of <b>Figure 23</b> From: Typical MDC/MDIO Read Operation To: Fast Link Drop Mechanism.....	42
• Moved text From the end of <b>Table 10</b> To <i>PHY Identifier Register #1 (PHYIDR1)</i> .....	57
• Changed format of loopback control bits in <b>Table 30</b> "BIST Control Register (BISCR)" .....	75
• Changed BIT NAME (11:8) From: "LED_ACT_SEL To: LED_2_SEL in <b>Table 32</b> .....	77
• Changed BIT NAME (7:4) From: "LED_SPD_SEL To: LED_1_SEL in <b>Table 32</b> .....	78
• Changed BIT NAME (3:0) From: "LED_LNK_SEL To: LED_0_SEL in <b>Table 32</b> .....	78
• Changed the title of <b>Table 45</b> from: Address 0x006FE to: Address 0x006F .....	87
• Changed default of bits 12:8 to 0 1100 in <b>Table 96</b> .....	97
• Deleted text "of the 64-HTQFP package" from the second paragraph in section <i>Cable Line Driver</i> .....	110
• Deleted text "for MII Mode" from the second paragraph in section <i>Clock In (XI) Recommendation</i> .....	111

## 5 Device Comparison

Table 1. Device Features Comparison

DEVICE	MAC	TEMPERATURE RANGE		TEMPERATURE GRADE
DP83867CRRGZ	RGMII	0°C	70°C	Commercial
DP83867IRRGZ	RGMII	-40°C	85°C	Industrial
DP83867IRPAP	MII/GMII/RGMII	-40°C	85°C	Industrial

## 6 Pin Configuration and Functions

PAP Package  
64-Pin HTQFP  
Top View

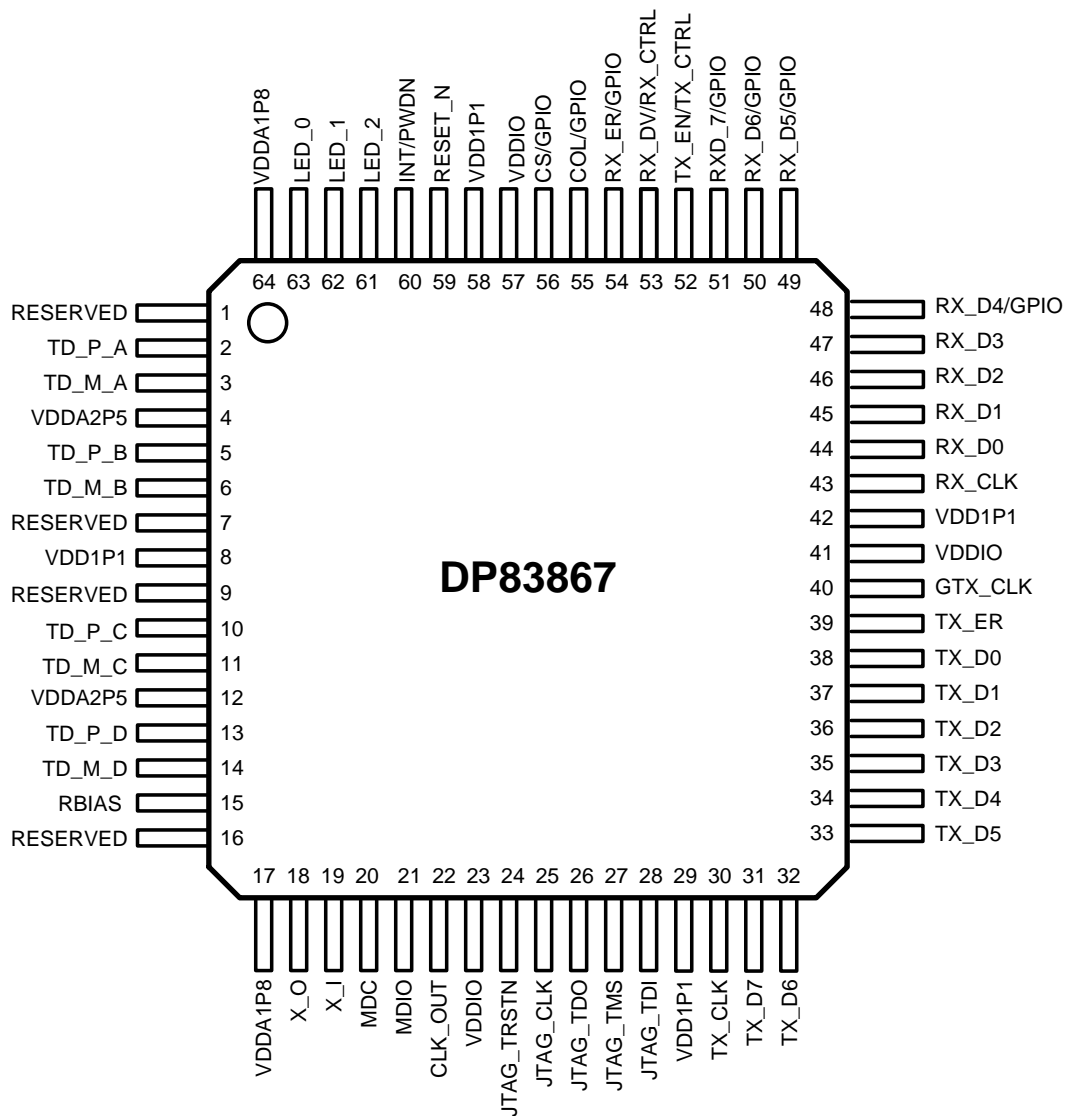

**RGZ Package  
48-Pin QFN  
Top View**

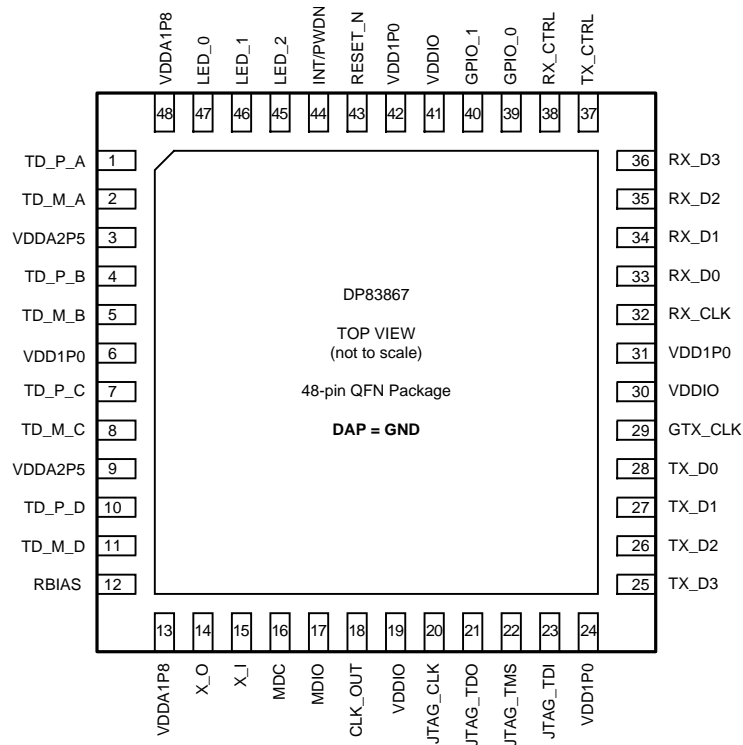

### Pin Functions

PIN			TYPE <sup>(1)</sup>	DESCRIPTION
NAME	HTQFP	VQFN		
<b>MAC INTERFACES</b>	<b>RGMII, GMII, MII</b>	<b>RGMII</b>		
TX_CLK	30		O	MII TRANSMIT CLOCK: TX_CLK is a continuous clock signal driven by the PHY during 10 Mbps or 100 Mbps MII mode. TX_CLK clocks the data or error out of the MAC layer and into the PHY.  The TX_CLK clock frequency is 2.5 MHz in 10BASE-T <sub>e</sub> and 25 MHz in 100BASE-TX mode.
TX_D7	31		I, PD	GMII TRANSMIT DATA Bit 7: This signal carries data from the MAC to the PHY in GMII mode. It is synchronous to the transmit clock GTX_CLK.
TX_D6	32		I, PD	GMII TRANSMIT DATA Bit 6: This signal carries data from the MAC to the PHY in GMII mode. It is synchronous to the transmit clock GTX_CLK.
TX_D5	33		I, PD	GMII TRANSMIT DATA Bit 5: This signal carries data from the MAC to the PHY in GMII mode. It is synchronous to the transmit clock GTX_CLK.
TX_D4	34		I, PD	GMII TRANSMIT DATA Bit 4: This signal carries data from the MAC to the PHY in GMII mode. It is synchronous to the transmit clock GTX_CLK.
TX_D3	35	25	I, PD	TRANSMIT DATA Bit 3: This signal carries data from the MAC to the PHY in GMII, RGMII, and MII modes. In GMII and RGMII modes, it is synchronous to the transmit clock GTX_CLK. In MII mode, it is synchronous to the transmit clock TX_CLK.
TX_D2	36	26	I, PD	TRANSMIT DATA Bit 2: This signal carries data from the MAC to the PHY in GMII, RGMII, and MII modes. In GMII and RGMII modes, it is synchronous to the transmit clock GTX_CLK. In MII mode, it is synchronous to the transmit clock TX_CLK.
TX_D1	37	27	I, PD	TRANSMIT DATA Bit 1: This signal carries data from the MAC to the PHY in GMII, RGMII, and MII modes. In GMII and RGMII modes, it is synchronous to the transmit clock GTX_CLK. In MII mode, it is synchronous to the transmit clock TX_CLK.
TX_D0	38	28	I, PD	TRANSMIT DATA Bit 0: This signal carries data from the MAC to the PHY in GMII, RGMII, and MII modes. In GMII and RGMII modes, it is synchronous to the transmit clock GTX_CLK. In MII mode, it is synchronous to the transmit clock TX_CLK.
TX_ER	39		I, PD	GMII TRANSMIT ERROR: This signal is used in GMII mode to force the PHY to transmit invalid symbols. The TX_ER signal is synchronous to the GMII transmit clock GTX_CLK.  In MII 4B nibble mode, assertion of Transmit Error by the controller causes the PHY to issue invalid symbols followed by Halt (H) symbols until deassertion occurs.  In GMII mode, assertion causes the PHY to emit one or more code-groups that are invalid data or delimiter in the transmitted frame.
GTX_CLK	40	29	I, PD	GMII and RGMII TRANSMIT CLOCK: This continuous clock signal is sourced from the MAC layer to the PHY. Nominal frequency is 125 MHz.
RX_CLK	43	32	O	RECEIVE CLOCK: Provides the recovered receive clocks for different modes of operation:  2.5 MHz in 10-Mbps mode.  25 MHz in 100-Mbps mode.  125 MHz in 1000-Mbps GMII and RGMII mode.
RX_D0	44	33	S, O, PD	RECEIVE DATA Bit 0: This signal carries data from the PHY to the MAC in GMII, RGMII, and MII modes. It is synchronous to the receive clock RX_CLK.

- (1) The functionalities of the pins are defined below.
- (a) Type I: Input
  - (b) Type O: Output
  - (c) Type I/O: Input /Output
  - (d) Type PD or PU: Internal Pull-down or Pull-up
  - (e) Type S: Strap Configuration Pin
  - (f) Type: A Analog pins

NOTE: Internal Pull-Up/Pull-Down resistors on the IO pins are disabled when the device enters functional mode after power up.

**Pin Functions (continued)**

PIN			TYPE <sup>(1)</sup>	DESCRIPTION
NAME	HTQFP	VQFN		
RX_D1	45	34	O, PD	RECEIVE DATA Bit 1: This signal carries data from the PHY to the MAC in GMII, RGMII, and MII modes. It is synchronous to the receive clock RX_CLK.
RX_D2	46	35	S, O, PD	RECEIVE DATA Bit 2: This signal carries data from the PHY to the MAC in GMII, RGMII, and MII modes. It is synchronous to the receive clock RX_CLK.
RX_D3	47	36	O, PD	RECEIVE DATA Bit 3: This signal carries data from the PHY to the MAC in GMII, RGMII, and MII modes. It is synchronous to the receive clock RX_CLK.
RX_D4	48		S, O, PD	RECEIVE DATA Bit 4: This signal carries data from the PHY to the MAC in GMII mode. It is synchronous to the receive clock RX_CLK.
RX_D5	49		S, O, PD	RECEIVE DATA Bit 5: This signal carries data from the PHY to the MAC in GMII mode. It is synchronous to the receive clock RX_CLK.
RX_D6	50		S, O, PD	RECEIVE DATA Bit 6: This signal carries data from the PHY to the MAC in GMII mode. It is synchronous to the receive clock RX_CLK.
RX_D7	51		S, O, PD	RECEIVE DATA Bit 7: This signal carries data from the PHY to the MAC in GMII mode. It is synchronous to the receive clock RX_CLK.
TX_EN / TX_CTRL	52	37	O, PD	<p>TRANSMIT ENABLE or TRANSMIT CONTROL: In MII or GMII mode, it is an active high input sourced from MAC layer to indicate transmission data is available on the TXD.</p> <p>In RGMII mode, it combines the transmit enable and the transmit error signals of GMII mode using both clock edges.</p>
RX_DV / RX_CTRL (Straps Required)	53	38	S, O, PD	<p>RECEIVE DATA VALID or RECEIVE CONTROL: In MII and GMII modes, it is asserted high to indicate that valid data is present on the corresponding RXD[3:0] in MII mode and RXD[7:0] in GMII mode.</p> <p>In RGMII mode, the receive data available and receive error are combined (RXDV_ER) using both rising and falling edges of the receive clock (RX_CLK).</p>
RX_ER / GPIO	54		O, PD	<p>RECEIVE ERROR: In 10 Mbps, 100 Mbps and 1000 Mbps mode this active high output indicates that the PHY has detected a Receive Error. The RX_ER signal is synchronous with the receive clock (RX_CLK).</p> <p>In RGMII, the RX_ER pin is not used.</p>
COL / GPIO	55		O, PD	<p>COLLISION DETECT: Asserted high to indicate detection of a collision condition (assertion of CRS due to simultaneous transmit and receive activity) in Half-Duplex modes. This signal is not synchronous to either MII clock (GTX_CLK, TX_CLK or RX_CLK).</p> <p>This signal is not defined and stays low for Full-Duplex modes.</p> <p>In RGMII mode, COL is not used.</p>
CRS	56		S, O, PD	<p>CARRIER SENSE: CRS is asserted high to indicate the presence of a carrier due to receive or transmit activity in Half-Duplex mode.</p> <p>For 10BASE-T<sub>e</sub> and 100BASE-TX Full-Duplex operation CRS is asserted when a received packet is detected. This signal is not defined for 1000BASE-T Full-Duplex mode.</p> <p>In RGMII mode, CRS is not used.</p>

**Pin Functions (continued)**

PIN			TYPE <sup>(1)</sup>	DESCRIPTION
NAME	HTQFP	VQFN		
<b>GENERAL PURPOSE I/O</b>				
GPIO_0		39	S, O, PD	General Purpose I/O: This signal provides a multi-function configurable I/O. Please refer to the GPIO_MUX_CTRL register for details.
GPIO_1		40	S, O, PD	General Purpose I/O: This signal provides a multi-function configurable I/O. Please refer to the GPIO_MUX_CTRL register for details.
<b>MANAGEMENT INTERFACE</b>				
MDC	20	16	I, PD	MANAGEMENT DATA CLOCK: Synchronous clock to the MDIO serial management input/output data. This clock may be asynchronous to the MAC transmit and receive clocks. The maximum clock rate is 25MHz and no minimum.
MDIO	21	17	I/O	MANAGEMENT DATA I/O: Bi-directional management instruction/data signal that may be sourced by the management station or the PHY. This pin requires pullup resistor. The IEEE specified resistor value is 1.5kΩ, but a 2.2kΩ is acceptable.
$\overline{\text{INT}} / \overline{\text{PWRDN}}$	60	44	I/O, PU	<p><b>INTERRUPT / POWER DOWN:</b></p> <p>The default function of this pin is POWER DOWN.</p> <p><b>POWER DOWN:</b> Asserting this signal low enables the Power Down mode of operation. In this mode, the device will power down and consume minimum power. Register access will be available through the Management Interface to configure and power up the device.</p> <p><b>INTERRUPT:</b> This pin may be programmed as an interrupt output instead of a Power down input. In this mode, Interrupts will be asserted low using this pin. When operating this pin as an interrupt, it is an open-drain architecture. Register access is required for the pin to be used as an interrupt mechanism. When operating this pin as an interrupt, an external 2.2kΩ connected to the VDDIO supply is recommended.</p>
<b>RESET</b>				
RESET_N	59	43	I, PU	RESET: The active low RESET initializes or re-initializes the DP83867. All internal registers will re-initialize to their default state upon assertion of RESET. The RESET input must be held low for a minimum of 1μs.
<b>CLOCK INTERFACE</b>				
XI	19	15	I	CRYSTAL/OSCILLATOR INPUT: 25 MHz oscillator or crystal input (50 ppm)
XO	18	14	O	CRYSTAL OUTPUT: Second terminal for 25 MHz crystal. Must be left floating if a clock oscillator is used.
CLK_OUT	22	18	O	CLOCK OUTPUT: Output clock
<b>JTAG INTERFACE</b>				
JTAG_CLK	25	20	I, PU	JTAG TEST CLOCK: IEEE 1149.1 Test Clock input, primary clock source for all test logic input and output controlled by the testing entity.
JTAG_TDO	26	21	O	JTAG TEST DATA OUTPUT: IEEE 1149.1 Test Data Output pin, the most recent test results are scanned out of the device via TDO.
JTAG_TMS	27	22	I, PU	JTAG TEST MODE SELECT: IEEE 1149.1 Test Mode Select pin, the TMS pin sequences the Tap Controller (16-state FSM) to select the desired test instruction.
JTAG_TDI	28	23	I, PU	JTAG TEST DATA INPUT: IEEE 1149.1 Test Data Input pin, test data is scanned into the device via TDI.
JTAG_TRSTN	24		I, PU	JTAG TEST RESET: IEEE 1149.1 Test Reset pin, active low reset provides for asynchronous reset of the Tap Controller. This reset has no effect on the device registers.

**Pin Functions (continued)**

PIN			TYPE <sup>(1)</sup>	DESCRIPTION
NAME	HTQFP	VQFN		
<b>LED INTERFACE</b>				
LED_2	61	45	S, I/O, PD	LED_2: By default, this pin indicates receive or transmit activity. Additional functionality is configurable via LEDCR1[11:8] register bits. NOTE: This pin is a Strap Configuration pin for RGZ devices only.
LED_1	62	46	S, I/O, PD	LED_1: By default, this pin indicates that 1000BASE-T link is established. Additional functionality is configurable via LEDCR1[7:4] register bits.
LED_0	63	47	S, I/O, PD	LED_0: By default, this pin indicates that link is established. Additional functionality is configurable via LEDCR1[3:0] register bits.
<b>MEDIA DEPENDENT INTERFACE</b>				
TD_P_A	2	1	A	Differential Transmit and Receive Signals
TD_M_A	3	2	A	Differential Transmit and Receive Signals
TD_P_B	5	4	A	Differential Transmit and Receive Signals
TD_M_B	6	5	A	Differential Transmit and Receive Signals
TD_P_C	10	7	A	Differential Transmit and Receive Signals
TD_M_C	11	8	A	Differential Transmit and Receive Signals
TD_P_D	13	10	A	Differential Transmit and Receive Signals
TD_M_D	14	11	A	Differential Transmit and Receive Signals
<b>OTHER PINS</b>				
Reserved	1, 7, 9, 16		A	Reserved
RBIAS	15	12	A	Bias Resistor Connection. A 11 kΩ +/-1% resistor should be connected from RBIAS to GND.
<b>POWER AND GROUND PINS</b>				
VDDIO	23, 41, 57	19, 30, 41	P	I/O Power: 1.8V (±5%), 2.5V (±5%) or 3.3V (±5%). Each pin requires a 1μF & 0.1μF capacitor to GND
VDDA1P8	17, 64	13, 48	P	1.8V Analog Supply (+/-5%). No external supply is required for this pin. When unused, no connections should be made to this pin. For additional power savings, an external 1.8V supply can be connected to these pins. When using an external supply, each pin requires a 1μF & 0.1μF capacitor to GND.
VDDA2P5	4, 12	3, 9	P	2.5V Analog Supply (+/-5%). Each pin requires a 1μF & 0.1μF capacitor to GND
VDD1P1	8, 29, 42, 58		P	1.1V Analog Supply (+/-5%). Each pin requires a 1μF & 0.1μF capacitor to GND
VDD1P0		6, 24, 31, 42	P	1.0V Analog Supply (+15.5%, -5%). Each pin requires a 1μF & 0.1μF capacitor to GND
GND	Die Attach Pad	Die Attach Pad	P	Ground

## 6.1 Unused Pins

DP83867 has internal pullups or pulldowns on most pins. The data sheet details which pins have internal pullups or pulldowns and which pins require external pull resistors.

Even though a device may have internal pullup or pulldown resistors, a good practice is to terminate unused inputs rather than allowing them to float. Floating inputs could result in unstable conditions. This recommendation does not apply to VDD1P8 pins. When unused, these pins should be left floating. It is considered a safer practice to pull an unused input pin high or low with a pullup or pulldown resistor. It is also possible to group together adjacent unused input pins, and as a group pull them up or down using a single resistor.

## 7 Specifications

### 7.1 Absolute Maximum Ratings

over operating free-air temperature range (unless otherwise noted) <sup>(1)</sup>

		MIN	MAX	UNIT	
Supply voltage	VDDA2P5	-0.3	3	V	
	VDDA1P8	-0.3	2.1		
	(VDD1P1/VDD1P0)	-0.3	1.3		
	VDDIO	3.3-V option	-0.3		3.8
		2.5-V option	-0.3		3
1.8-V option		-0.3	2.1		
Pins	MDI	-0.3	6.5	V	
	MAC interface, MDIO, MDC, GPIO	-0.3	VDDIO + 0.3		
	INT/PWDN, RESET	-0.3	VDDIO + 0.3		
	JTAG	-0.3	VDDIO + 0.3		
Storage temperature, T <sub>stg</sub>		-60	150	°C	

(1) Stresses beyond those listed under *Absolute Maximum Ratings* may cause permanent damage to the device. These are stress ratings only, which do not imply functional operation of the device at these or any other conditions beyond those indicated under *Recommended Operating Conditions*. Exposure to absolute-maximum-rated conditions for extended periods may affect device reliability.

### 7.2 ESD Ratings

			VALUE	UNIT
V <sub>(ESD)</sub> Electrostatic discharge	Human-body model (HBM), per ANSI/ESDA/JEDEC JS-001 <sup>(1)</sup>	All pins except Media Dependent Interface pins	±2500	V
		Media Dependent Interface pins (IRPAP/IRRGZ) <sup>(2)</sup>	±8000	
		Media Dependent Interface pins (CRRGZ)	±6000	
	Charged-device model (CDM), per JEDEC specification JESD22-C101 <sup>(3)</sup>	±1500 (RGZ) ±750 (PAP)		

- (1) JEDEC document JEP155 states that 500-V HBM allows safe manufacturing with a standard ESD control process. Manufacturing with less than 500-V HBM is possible with the necessary precautions. Pins listed as ±8 V and/or ±2 V may actually have higher performance.
- (2) MDI Pins tested as per IEC 61000-4-2 standards.
- (3) JEDEC document JEP157 states that 250-V CDM allows safe manufacturing with a standard ESD control process. Manufacturing with less than 250-V CDM is possible with the necessary precautions. Pins listed as ±500 V may actually have higher performance.

### 7.3 Recommended Operating Conditions

over operating free-air temperature range (unless otherwise noted)

		MIN	TYP	MAX	UNIT	
Supply voltage	VDDA2P5	2.375	2.5	2.625	V	
	VDDA1P8	1.71	1.8	1.89		
	VDD1P1 (PAP)	1.045	1.1	1.155		
	VDD1P0 (RGZ)	0.95	1	1.155		
	VDDIO	3.3-V option	3.15	3.3		3.45
		2.5-V option	2.375	2.5		2.625
1.8-V option		1.71	1.8	1.89		
Operating free air temperature	Commercial (DP83867CRRGZ)	0	25	70	°C	
	Operating free air temperature Industrial (DP83867IRPAP)	-40	25	85	°C	
Operating junction temperature	Commercial (DP83867CRRGZ)	0		90	°C	
	Industrial (DP83867IRRGZ)	-40		105	°C	
	Industrial (DP83867IRPAP)					

## 7.4 Thermal Information

THERMAL METRIC <sup>(1)</sup>		DP83867IR	DP83867IR, DP83867CR	UNIT
		PAP (HTQFP)	RGZ (QFN)	
		64 PINS	48 PINS	
R <sub>θJA</sub>	Junction-to-ambient thermal resistance	30.9	30.8	°C/W
R <sub>θJC(top)</sub>	Junction-to-case (top) thermal resistance	13.6	18.7	°C/W
R <sub>θJC(bot)</sub>	Junction-to-case (bottom) thermal resistance	0.9	1.4	°C/W
R <sub>θJB</sub>	Junction-to-board thermal resistance	15.6	7.5	°C/W
ψ <sub>JT</sub>	Junction-to-top characterization parameter	0.4	0.3	°C/W
ψ <sub>JB</sub>	Junction-to-board characterization parameter	15.5	7.5	°C/W

(1) For more information about traditional and new thermal metrics, see the [Semiconductor and IC Package Thermal Metrics](#) application report.

## 7.5 Electrical Characteristics

The electrical ratings specified in this section apply to all specifications in this document, unless otherwise noted. These specifications are interpreted as conditions that do not degrade the device parametric or functional specifications for the life of the product containing it.

PARAMETER	TEST CONDITIONS	MIN	TYP	MAX	UNIT	
<b>3.3-V V<sub>DDIO</sub></b>						
V <sub>OH</sub>	High level output voltage	I <sub>OH</sub> = -4 mA	2		V	
V <sub>OL</sub>	Low level output voltage	I <sub>OL</sub> = 4 mA		0.6	V	
V <sub>IH</sub>	High level input voltage		1.7		V	
V <sub>IL</sub>	Low level input voltage			0.7	V	
<b>2.5-V V<sub>DDIO</sub></b>						
V <sub>OH</sub>	High level output voltage	I <sub>OH</sub> = -4 mA	V <sub>DDIO</sub> × 0.8		V	
V <sub>OL</sub>	Low level output voltage	I <sub>OL</sub> = 4 mA		0.6	V	
V <sub>IH</sub>	High level input voltage		1.7		V	
V <sub>IL</sub>	Low level input voltage			0.7	V	
<b>1.8-V V<sub>DDIO</sub></b>						
V <sub>OH</sub>	High level output voltage	I <sub>OH</sub> = -1 mA	V <sub>DDIO</sub> - 0.2		V	
V <sub>OL</sub>	Low level output voltage	I <sub>OL</sub> = 1 mA		0.2	V	
V <sub>IH</sub>	High level input voltage		0.7 × V <sub>DDIO</sub>		V	
V <sub>IL</sub>	Low level input voltage			0.2 × V <sub>DDIO</sub>	V	
<b>DC CHARACTERISTICS</b>						
I <sub>IH</sub>	Input high current	V <sub>IN</sub> = V <sub>DD</sub> , T <sub>A</sub> = -40°C to +85°C	-10		10 μA	
I <sub>IL</sub>	Input low current	V <sub>IN</sub> = GND, T <sub>A</sub> = -40°C to +85°C	-10		10 μA	
I <sub>OZ</sub>	TRI-STATE output current	V <sub>OUT</sub> = V <sub>DD</sub> , V <sub>OUT</sub> = GND, T <sub>A</sub> = -40°C to +85°C	-10		10 μA	
C <sub>IN</sub>	Input capacitance	See <sup>(1)</sup>		5	pF	
<b>PMD OUTPUTS</b>						
V <sub>OD-10</sub>	MDI	IRPAP/IRRGZ	1.54	1.75	1.96	V Peak Differential
		CRRGZ		1.75		
V <sub>OD-100</sub>	MDI	IRPAP/IRRGZ	0.95	1	1.05	V Peak Differential
		CRRGZ		1		
V <sub>OD-1000</sub>	MDI	IRPAP/IRRGZ	0.67	0.745	0.82	V Peak Differential
		CRRGZ		0.745		

(1) Ensured by production test, characterization, or design.

## Electrical Characteristics (continued)

The electrical ratings specified in this section apply to all specifications in this document, unless otherwise noted. These specifications are interpreted as conditions that do not degrade the device parametric or functional specifications for the life of the product containing it.

PARAMETER		TEST CONDITIONS	MIN	TYP	MAX	UNIT
<b>POWER CONSUMPTION</b>						
<b>PAP</b>						
P1000	Power consumption, 2 supplies <sup>(2)(3)</sup>			530		mW
P1000	Power consumption, optional 3rd supply <sup>(2)(3)</sup>			490		mW
IDD25	Supply Current, 2 supplies			141		mA
IDD11				125		mA
IDDIO (1.8 V)				22		mA
IDD25	Supply Current, optional 3rd supply			90		mA
IDD11				125		mA
IDD18				51		mA
IDDIO (1.8 V)				19		mA
<b>RGZ</b>						
P1000	Power consumption, 2 supplies <sup>(2)(3)</sup>			495		mW
P1000	Power consumption, optional 3rd supply <sup>(2)(3)</sup>			457		mW
IDD25	Supply Current, 2 supplies			137		mA
IDD10				108		mA
IDDIO (1.8 V)				24		mA
IDD25	Supply Current, optional 3rd supply			86		mA
IDD10				108		mA
IDD18				50		mA
IDDIO (1.8 V)				24		mA

(2) Power consumption represents total operational power for 1000BASE-T.

(3) See [Power Supply Recommendations](#) for details on 2-supply and 3-supply configuration.

## 7.6 Power-Up Timing<sup>(1)</sup>

See [Figure 1](#).

PARAMETER		TEST CONDITIONS	MIN	NOM	MAX	UNIT
T1	Post power-up stabilization time prior to MDC preamble for register accesses	MDIO is pulled high for 32-bit serial management initialization.		200		ms
T2	Hardware configuration latch-in time from power up	Hardware Configuration Pins are described in <a href="#">Strap Configuration</a> .		200		ms
T3	Hardware configuration pins transition to output drivers			64		ns

(1) Ensured by production test, characterization, or design.

## 7.7 Reset Timing<sup>(1)</sup>

 See [Figure 2](#).

PARAMETER		TEST CONDITIONS	MIN	NOM	MAX	UNIT
T1	Post RESET stabilization time prior to MDC preamble for register accesses	MDIO is pulled high for 32-bit serial management initialization. MDC may toggle during this period when MDIO remains high.		195		μs
T2	Hardware configuration latch-in time from the deassertion of RESET (either soft or hard)	Hardware Configuration Pins are described in <a href="#">Strap Configuration</a> .		120		ns
T3	Hardware configuration pins transition to output drivers			64		ns
T4	RESET pulse width	X1 Clock must be stable for a minimum of 1 μs during RESET pulse low time	1			μs

(1) Ensured by production test, characterization, or design.

## 7.8 MII Serial Management Timing<sup>(1)</sup>

 See [Figure 3](#).

PARAMETER		TEST CONDITIONS	MIN	NOM	MAX	UNIT
T1	MDC to MDIO (output) delay time		0		10	ns
T2	MDIO (input) to MDC setup time		10			ns
T3	MDIO (input) to MDC hold time		10			ns
T4	MDC frequency			2.5	25	MHz

(1) Ensured by production test, characterization, or design.

## 7.9 RGMII Timing<sup>(1)</sup>

 See [Figure 4](#) and [Figure 4](#).

PARAMETER		TEST CONDITIONS	MIN	NOM	MAX	UNIT
T <sub>skewT</sub>	Data to Clock output Skew (at Transmitter)	See <sup>(2)</sup>	-500	0	500	ps
T <sub>skewR</sub>	Data to Clock input Skew (at Receiver)	See <sup>(2)</sup>	1	1.8	2.6	ns
T <sub>setupT</sub>	Data to Clock output Setup (at Transmitter – internal delay)	See <sup>(3)</sup>	1.2	2		ns
T <sub>holdT</sub>	Clock to Data output Hold (at Transmitter – internal delay)	See <sup>(3)</sup>	1.2	2		ns
T <sub>setupR</sub>	Data to Clock input Setup (at Receiver – internal delay)	See <sup>(3)</sup>	1	2		ns
T <sub>holdR</sub>	Data to Clock input Setup (at Receiver – internal delay)	See <sup>(3)</sup>	1	2		ns
T <sub>cyc</sub>	Clock Cycle Duration <sup>(4)</sup>	See <sup>(4)</sup>	7.2	8	8.8	ns
Duty_G	Duty Cycle for Gigabit <sup>(5)</sup>	See <sup>(5)</sup>	45	50	55%	
Duty_T	Duty Cycle for 10/100T <sup>(5)</sup>	See <sup>(5)</sup>	40	50	60%	
T <sub>R</sub>	Rise Time (20% to 80%)				0.75	ns
T <sub>F</sub>	Fall Time (20% to 80%)				0.75	ns
T <sub>TXLAT</sub>	RGMII to MDI Latency	See <sup>(6)</sup>		88		ns
T <sub>RXLAT</sub>	MDI to RGMII Latency	See <sup>(6)</sup>		288		ns

(1) Ensured by production test, characterization, or design.

(2) When operating without RGMII internal delay, the PCB design requires clocks to be routed such that an additional trace delay of greater than 1.5 ns is added to the associated clock signal.

(3) Device may operate with or without internal delay.

 (4) For 10-Mbps and 100-Mbps, T<sub>cyc</sub> will scale to 400 ns ± 40 ns and 40 ns ± 4 ns.

 (5) Duty cycle may be stretched or shrunk during speed changes or while transitioning to a received packet's clock domain as long as minimum duty cycle is not violated and stretching occurs for no more than three T<sub>cyc</sub> of the lowest speed transitioned between.

(6) Operating in 1000Base-T.

## 7.10 GMII Transmit Timing<sup>(1)</sup>

 See [Figure 6](#).

	PARAMETER	TEST CONDITIONS	MIN	NOM	MAX	UNIT
T1	GTX_CLK Duty Cycle		40%		60%	
T2	GTX_CLK Rise / Fall Time				1	ns
T3	Setup from valid TXD, TX_EN and TX_ER to rising edge of GTX_CLK		2			ns
T4	Hold from rising edge of GTX_CLK to invalid TXD, TX_EN, and TX_ER		0.5			ns
T5	GTX_CLK Stability		-100		100	ppm
T6	GMII to MDI Latency	See <sup>(2)</sup>		72		ns

(1) Ensured by production test, characterization, or design.

(2) Operating in 1000Base-T.

## 7.11 GMII Receive Timing<sup>(1)</sup>

 See [Figure 7](#).

	PARAMETER	TEST CONDITIONS	MIN	NOM	MAX	UNIT
T1	Rising edge of RX_CLK to RXD, RX_DV, and RX_ER delay		0.5		5.5	ns
T2	RX_CLK Duty Cycle		40%		60%	
T3	RX_CLK Rise / Fall Time				1	ns
T4	MDI to GMII Latency	See <sup>(2)</sup>		264		ns

(1) Ensured by production test, characterization, or design.

(2) Operating in 1000Base-T.

## 7.12 100-Mbps MII Transmit Timing<sup>(1)</sup>

 See [Figure 8](#).

	PARAMETER	TEST CONDITIONS	MIN	NOM	MAX	UNIT
T1	TX_CLK High/Low Time		16	20	24	ns
T2	TXD[3:0], TX_EN Data Setup to TX_CLK		10			ns
T3	TXD[3:0], TX_EN Data Hold from TX_CLK		0			ns

(1) Ensured by production test, characterization, or design.

## 7.13 100-Mbps MII Receive Timing<sup>(1)</sup>

 See [Figure 9](#).

	PARAMETER	TEST CONDITIONS	MIN	NOM	MAX	UNIT
T1	RX_CLK High/Low Time	See <sup>(2)</sup>	16	20	24	ns
T2	RX_CLK to RXD[3:0], RX_DV, RX_ER Delay		10		30	ns

(1) Ensured by production test, characterization, or design.

(2) RX\_CLK may be held low or high for a longer period of time during transition between reference and recovered clocks. Minimum high and low times will not be violated.

## 7.14 10-Mbps MII Transmit Timing<sup>(1)</sup>

 See [Figure 10](#).

PARAMETER		TEST CONDITIONS	MIN	NOM	MAX	UNIT
T1	TX_CLK High/Low Time	See <sup>(2)</sup>	190	200	210	ns
T2	TXD[3:0], TX_EN Data Setup to TX_CLK falling edge		25			ns
T3	TXD[3:0], TX_EN Data Hold from TX_CLK rising edge		0			ns

(1) Ensured by production test, characterization, or design.

(2) An attached MAC should drive the transmit signals using the positive edge of TX\_CLK. As shown below, the MII signals are sampled on the falling edge of TX\_CLK.

## 7.15 10-Mbps MII Receive Timing<sup>(1)</sup>

 See [Figure 11](#).

PARAMETER		TEST CONDITIONS	MIN	NOM	MAX	UNIT
T1	RX_CLK High/Low Time	See <sup>(2)</sup>	160	200	240	ns
T2	RXD[3:0], RX_DV transition delay from RX_CLK rising edge		100		300	ns
T3	RX_CLK rising edge delay from RXD[3:0], RX_DV valid data		100			

(1) Ensured by production test, characterization, or design.

(2) RX\_CLK may be held low for a longer period of time during transition between reference and recovered clocks. Minimum high and low times will not be violated.

## 7.16 DP83867IR/CR Start of Frame Detection Timing

 See [Figure 12](#).

PARAMETER		TEST CONDITIONS	MIN	NOM	MAX	UNIT
T1	Transmit SFD variation <sup>(1)(2)</sup>	1000-Mb Master	0		0	ns
		1000-Mb Slave	0		0	ns
		100-Mb	0		16	ns
T2	Receive SFD variation <sup>(1)(2)</sup>	1000-Mb Master	-8		8	ns
		1000-Mb Slave	-8		8	ns
		100-Mb	0		0	ns

(1) A larger variation may be seen on SFD pulses than the variation specified here. To achieve the determinism specification listed, see the [SFD Latency Variation and Determinism](#) section for a method to compensate for variation in the SFD pulses.

(2) Variation of SFD pulses occurs from link-up to link-up. Packet to packet variation is fixed using the estimation method in [SFD Latency Variation and Determinism](#).

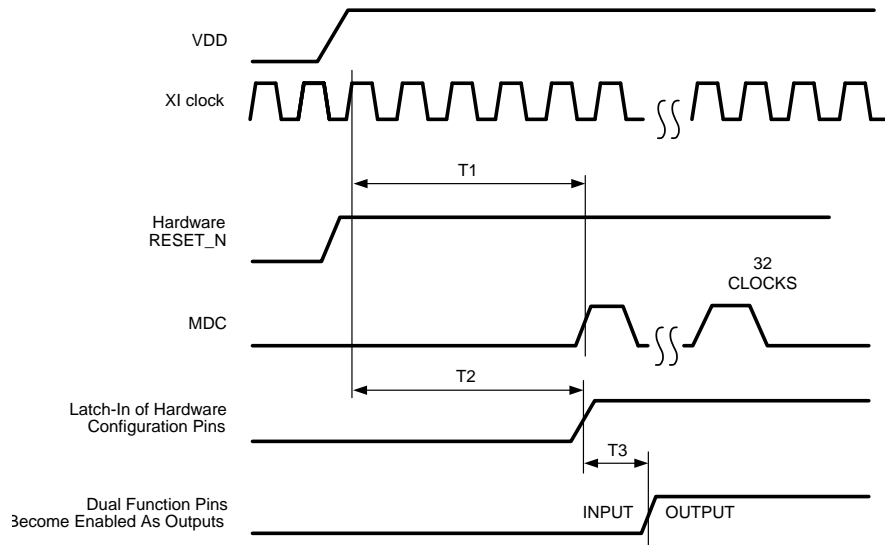

Figure 1. Power-Up Timing

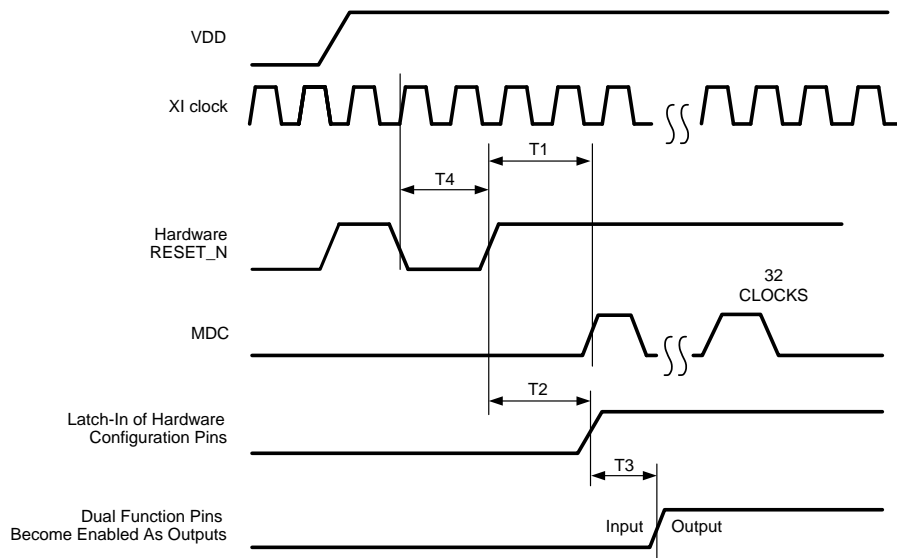

Figure 2. Reset Timing

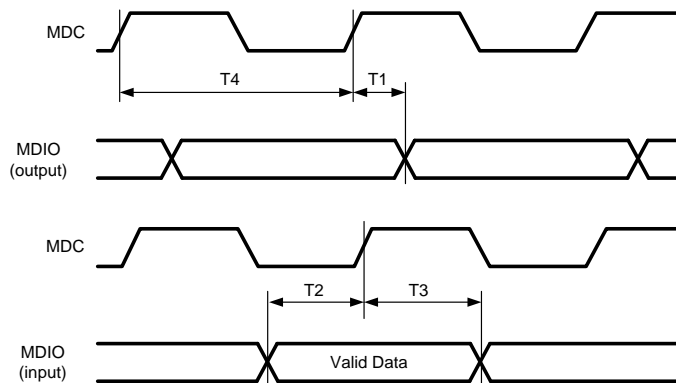

Figure 3. MII Serial Management Timing

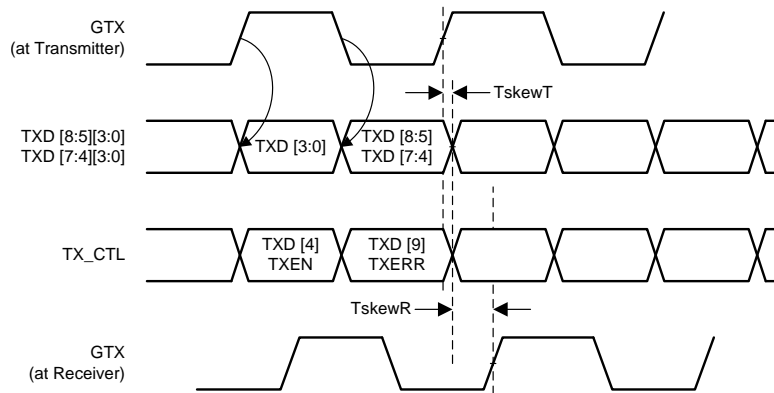

Figure 4. RGMII Transmit Multiplexing and Timing Diagram

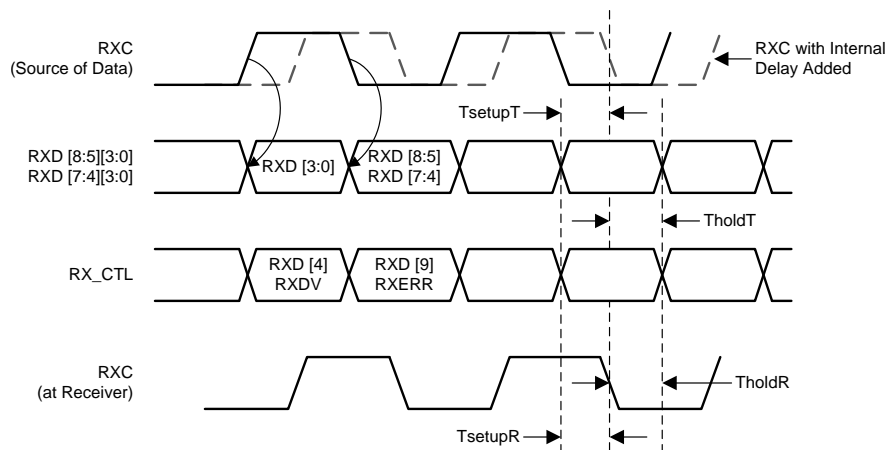

Figure 5. RGMII Receive Multiplexing and Timing Diagram

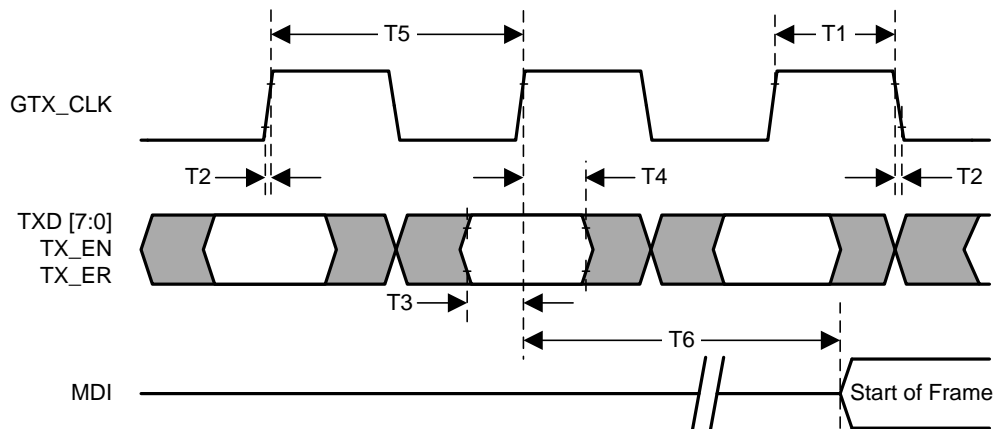

Figure 6. GMII Transmit Timing

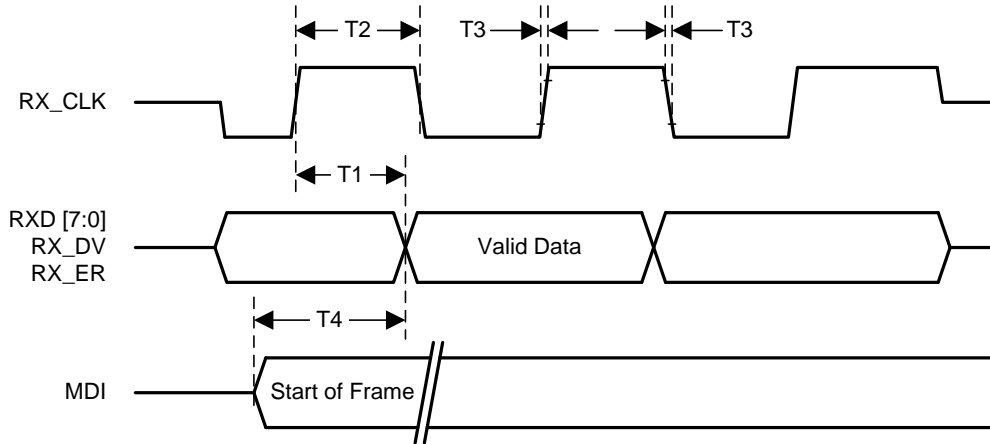

Figure 7. GMII Receive Timing

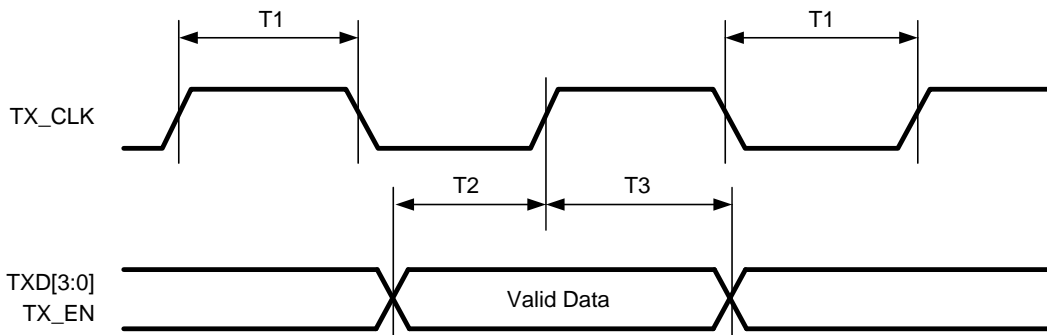

Figure 8. 100-Mbps MII Transmit Timing

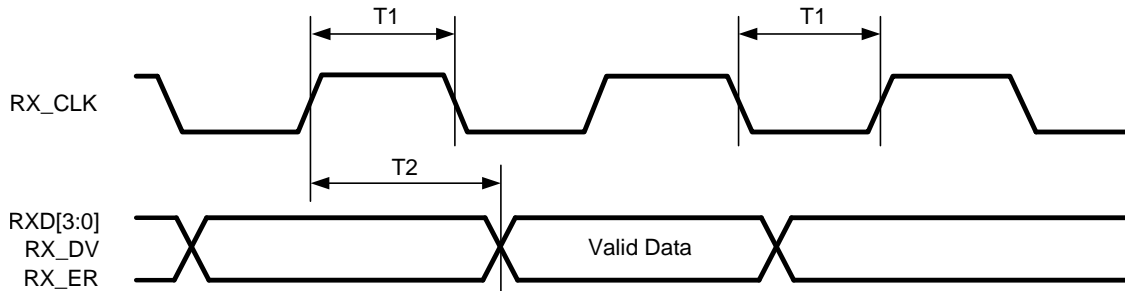

Figure 9. 100-Mbps MII Receive Timing

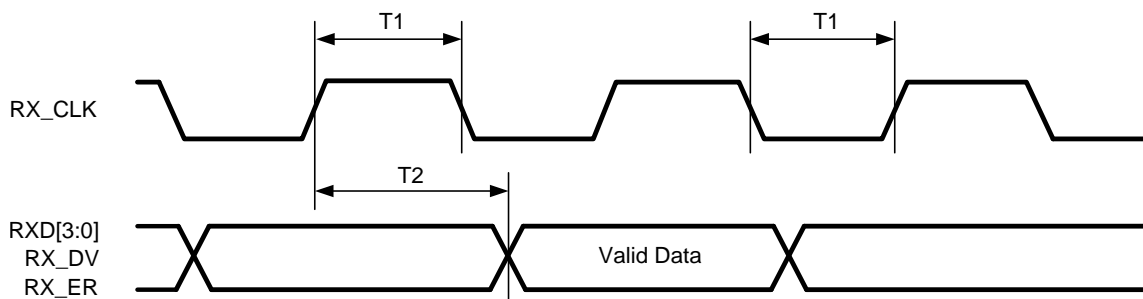
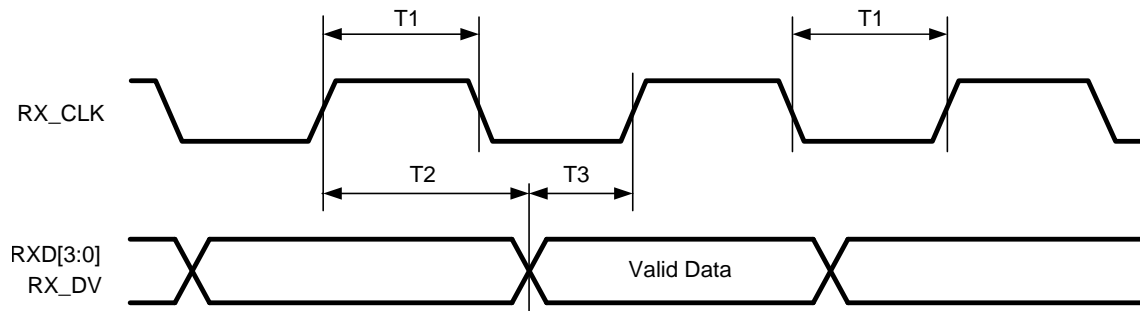
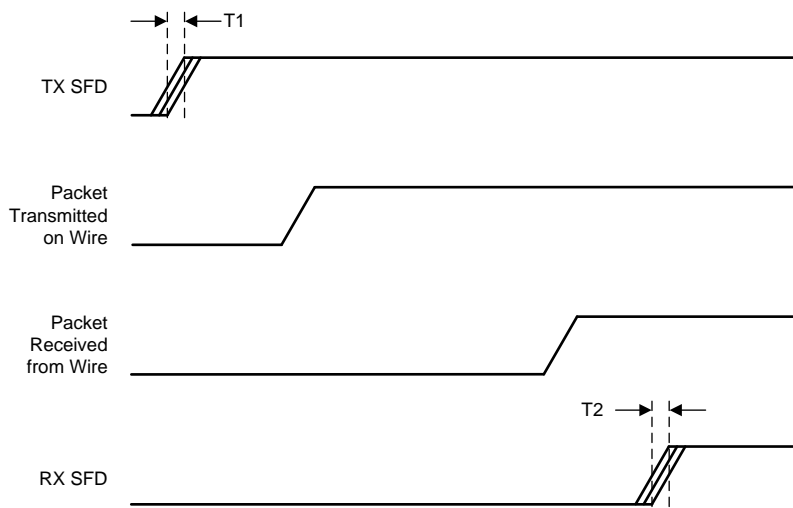

Figure 10. 10-Mbps MII Transmit Timing

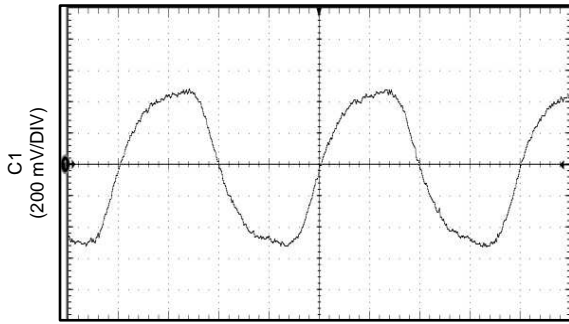

**Figure 11. 10-Mbps MII Receive Timing**



**Figure 12. DP83867IR/CR Start of Frame Delimiter Timing**

## 7.17 Typical Characteristics



1000Base-T Signaling  
(Test Mode TM2 Output)

Figure 13. 1000Base-T Signaling

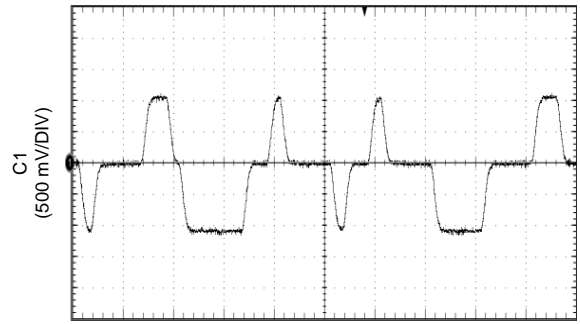

100Base-TX Signaling  
(Scrambled Idles)

Figure 14. 100Base-TX Signaling

## 8 Detailed Description

### 8.1 Overview

The DP83867 is a fully featured Physical Layer transceiver with integrated PMD sublayers to support 10BASE-T<sub>e</sub>, 100BASE-TX and 1000BASE-T Ethernet protocols.

The DP83867 is designed for easy implementation of 10/100/1000 Mbps Ethernet LANs. It interfaces directly to twisted pair media via an external transformer. This device interfaces directly to the MAC layer through the IEEE 802.3u Standard Media Independent Interface (MII), the IEEE 802.3z Gigabit Media Independent Interface (GMII), or Reduced GMII (RGMII).

The DP83867 provides precision clock synchronization, including a synchronous Ethernet clock output. It has low jitter, low latency and provides IEEE 1588 Start of Frame Detection for time sensitive protocols.

The DP83867 offers innovative diagnostic features including dynamic link quality monitoring for fault prediction during normal operation. It can support up to 130-m cable length.

## 8.2 Functional Block Diagram

### DP83867IRPAP

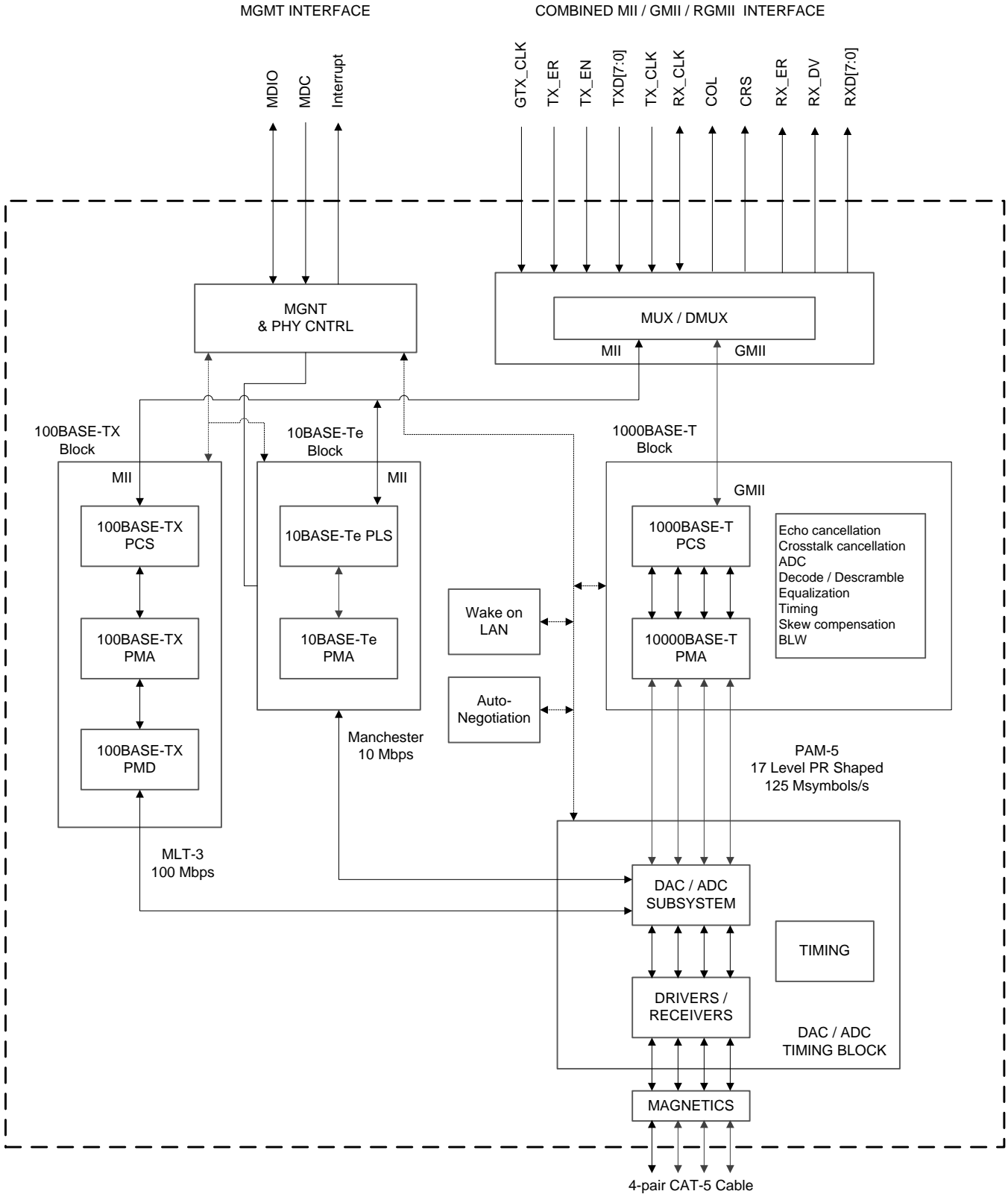

### Functional Block Diagram (continued)

#### DP83867IRRGZ, DP83867CRRGZ

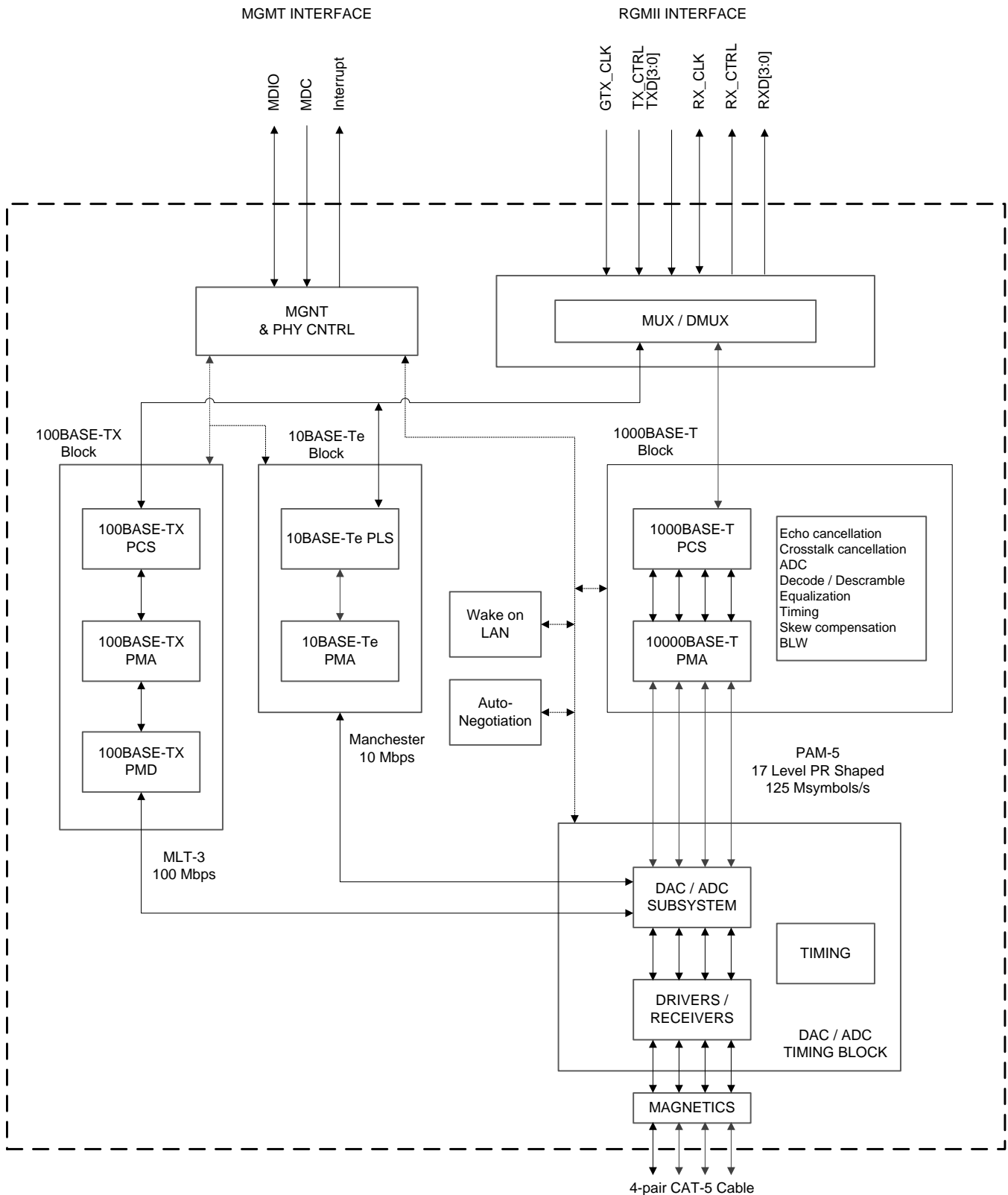

## 8.3 Feature Description

### 8.3.1 WoL (Wake-on-LAN) Packet Detection

Wake-on-LAN provides a mechanism for bringing the DP83867 out of a low-power state using a special Ethernet packet called a Magic Packet. The DP83867 can be configured to generate an interrupt to wake up the MAC when a qualifying packet is received. An option is also available to generate a signal on a GPIO when a qualifying signal is received.

The Wake-on-LAN feature includes the following functionality:

- Identification of magic packets in all supported speeds (1000BASE-T, 100BASE-TX, 10BASE-Te)
- Wakeup interrupt generation upon receiving a valid magic packet
- CRC checking of magic packets to prevent interrupt generation for invalid packets

In addition to the basic magic packet support, the DP83867 also supports:

- Magic packets that include secure-on password
- Pattern match – one configurable 64 byte pattern of that can wake up the MAC similar to magic packet
- Independent configuration for Wake on Broadcast and Unicast packet types.

#### 8.3.1.1 Magic Packet Structure

When configured for Magic Packet mode, the DP83867 scans all incoming frames addressed to the node for a specific data sequence. This sequence identifies the frame as a Magic Packet frame.

---

#### NOTE

The Magic Packet should be byte aligned.

---

A Magic Packet frame must also meet the basic requirements for the LAN technology chosen, such as SOURCE ADDRESS, DESTINATION ADDRESS (which may be the receiving station's IEEE address or a BROADCAST address), and CRC.

The specific Magic Packet sequence consists of 16 duplications of the IEEE address of this node, with no breaks or interruptions, followed by secure-on password if security is enabled. This sequence can be located anywhere within the packet, but must be preceded by a synchronization stream. The synchronization stream is defined as 6 bytes of FFh.

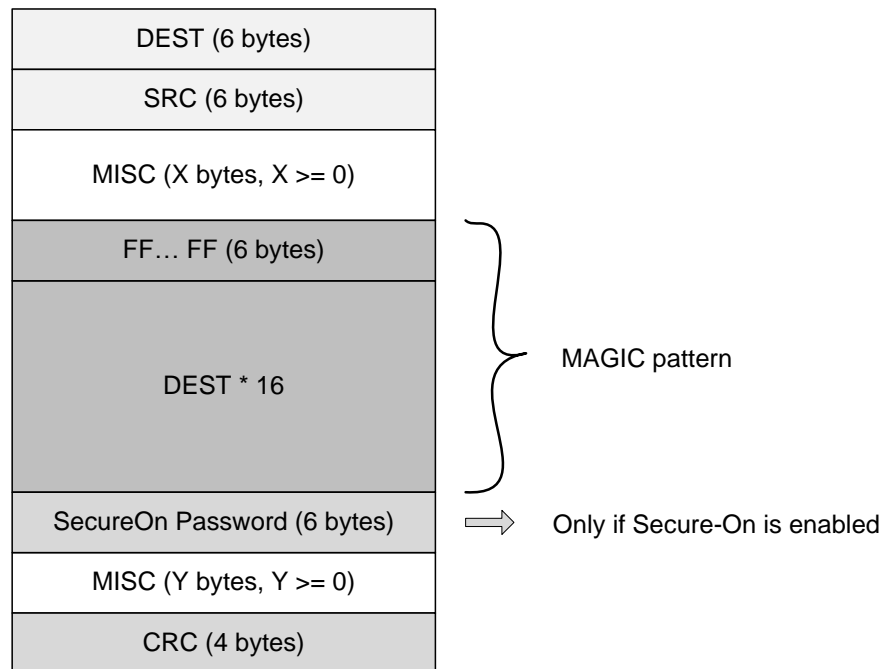
**Feature Description (continued)**

**Figure 15. Magic Packet Structure**
**8.3.1.2 Magic Packet Example**

The following is an example Magic Packet for a Destination Address of 11h 22h 33h 44h 55h 66h and a SecureOn Password 2Ah 2Bh 2Ch 2Dh 2Eh 2Fh:

```

DESTINATION SOURCE MISC FF FF FF FF FF FF 11 22 33 44 55 66 11 22 33 44 55 66 11 22 33 44 55 66 11 22
33 44 55 66 11 22 33 44 55 66 11 22 33 44 55 66 11 22 33 44 55 66 11 22 33 44 55 66 11 22 33 44 55 66
11 22 33 44 55 66 11 22 33 44 55 66 11 22 33 44 55 66 11 22 33 44 55 66 11 22 33 44 55 66 11 22 33 44
55 66 11 22 33 44 55 66 2A 2B 2C 2D 2E 2F MISC CRC
  
```

**8.3.1.3 Wake-on-LAN Configuration and Status**

Wake-on-LAN functionality is configured through the RXFCFG register (address 0x0134). Wake-on-LAN status is reported in the RXFSTS register (address 0x0135).

**8.3.2 Start of Frame Detect for IEEE 1588 Time Stamp**

The DP83867 supports an IEEE 1588 indication pulse at the SFD (start frame delimiter) for the receive and transmit paths. The pulse can be delivered to various pins. The pulse indicates the actual time the symbol is presented on the lines (for transmit), or the first symbol received (for receive). The exact timing of the pulse can be adjusted through register. Each increment of phase value is an 8-ns step.

Feature Description (continued)

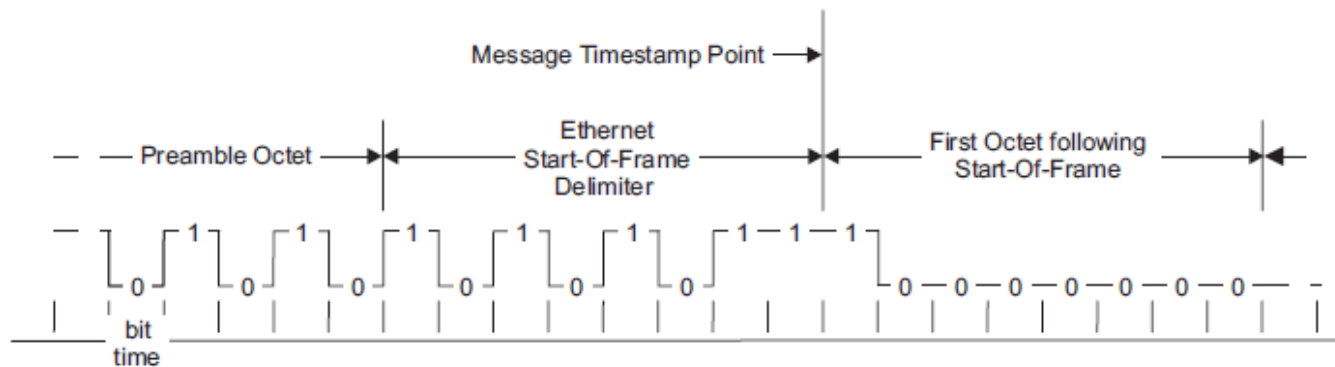

Figure 16. IEEE 1588 Message Timestamp Point

The SFD pulse output can be configured using the GPIO Mux Control registers, GPIO\_MUX\_CTRL1 (register address 0x0171) and GPIO\_MUX\_CTRL2 (register address 0x0172). The RGZ devices support only register GPIO\_MUX\_CTRL2 (address 0x172).

For more information about configuring the DP83867's SFD feature, see the [How to Configure DP83867 Start of Frame](#) application report (SNLA242).

8.3.2.1 SFD Latency Variation and Determinism

Time stamping packet transmission and reception using the RX\_CTRL and TX\_CTRL signals of RGMII is not accurate enough for latency sensitive protocols. SFD pulses offers system designers a method to improve the accuracy of packet time stamping. The SFD pulse, while varying less than RGMII signals inherently, still exhibits latency variation due to the defined architecture of 1000BASE-T. This section provides a method to determine when an SFD latency variation has occurred and how to compensate for the variation in system software to improve timestamp accuracy.

In the following section the terms baseline latency and SFD variation are used. Baseline latency is the time measured between the TX\_SFD pulse to the RX\_SFD pulse of a connected link partner, assuming an Ethernet cable with all 4 pairs perfectly matched in propagation time. In the scenario where all 4 pairs being perfectly matched, a 1000BASE-T PHY will not have to align the 4 received symbols on the wire and will not introduce extra latency due to alignment.

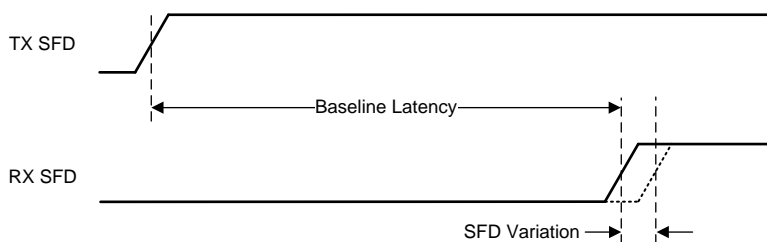

Figure 17. Baseline Latency and SFD Variation in Latency Measurement

SFD variation is additional time added to the baseline latency before the RX\_SFD pulse when the PHY must introduce latency to align the 4 symbols from the Ethernet cable. Variation can occur when a new link is established either by cable connection, auto-negotiation restart, PHY reset, or other external system effects. During a single, uninterrupted link, the SFD variation will remain constant.

## Feature Description (continued)

The DP83867 can limit and report the variation applied to the SFD pulse while in the 1000-Mb operating mode. Before a link is established in 1000-Mb mode, the Sync FIFO Control Register (register address 0x00E9) must be set to value 0xDF22. The below SFD variation compensation method can only be applied after the Sync FIFO Control Register has been initialized and a new link has been established. It is acceptable to set the Sync FIFO Control register value and then perform a software restart by setting the SW\_RESTART bit[14] in the Control Register (register address 0x001F) if a link is already present.

### 8.3.2.1.1 1000-Mb SFD Variation in Master Mode

When the DP83867 is operating in 1000-Mb master mode, variation of the RX\_SFD pulse can be estimated using the Skew FIFO Status register (register address 0x0055) bit[7:4]. The value read from the Skew FIFO Status register bit[7:4] must be multiplied by 8 ns to estimate the RX\_SFD variation added to the baseline latency.

Example: While operating in master 1000-Mb mode, a value of 0x2 is read from the Skew FIFO register bit[7:4].  $2 \times 8 \text{ ns} = 16 \text{ ns}$  is subtracted from the TX\_SFD to RX\_SFD measurement to determine the baseline latency.

### 8.3.2.1.2 1000-Mb SFD Variation in Slave Mode

When the DP83867 is operating in 1000-Mb slave mode, the variation of the RX\_SFD pulse can be determined using the Skew FIFO Status register (register address 0x0055) bit[3:0]. The value read from the Skew FIFO Status register bit[3:0] should be multiplied by 8ns to estimate the RX\_SFD variation added to the baseline latency.

Example: While operating in slave 1000-Mb mode, a value of 0x1 is read from the Skew FIFO register bit[3:0].  $1 \times 8 \text{ ns} = 8 \text{ ns}$  is subtracted from the TX\_SFD to RX\_SFD measurement to determine the baseline latency.

### 8.3.2.1.3 100-Mb SFD Variation

The latency variation in 100-Mb mode of operation is determined by random process and does not require any register readout or system level compensation of SFD pulses.

## 8.3.3 Clock Output

The DP83867 has several internal clocks, including the local reference clock, the Ethernet transmit clock, and the Ethernet receive clock. An external crystal or oscillator provides the stimulus for the local reference clock. The local reference clock acts as the central source for all clocking in the device.

The local reference clock is embedded into the transmit network packet traffic and is recovered from the network packet traffic at the receiver node. The receive clock is recovered from the received Ethernet packet data stream and is locked to the transmit clock in the partner.

Using the I/O Configuration register (address 0x0170), the DP83867 can be configured to output these internal clocks through the CLK\_OUT pin. By default, the output clock is synchronous to the XI oscillator / crystal input. Through registers, the output clock can be configured to be synchronous to the receive data at the 125-MHz data rate or at the divide by 5 rate of 25 MHz. It can also be configured to output the line driver transmit clock. When operating in 1000Base-T mode, the output clock can be configured for any of the four transmit or receive channels.

The output clock can be disabled using the CLK\_O\_DISABLE bit of the I/O Configuration register. It can also be disabled by default using the Clock Out Disable strap. This strap is only available for the PAP devices. For more information, see [Strap Configuration](#).

## 8.4 Device Functional Modes

### 8.4.1 MAC Interfaces

The DP83867 supports connection to an Ethernet MAC via the following interfaces: RGMII, GMII, and MII.

The RGMII Disable strap (RX\_D6) determines the default state of the MAC interface. The RGMII Disable strap corresponds to the RGMII Enable (bit 7) in the RGMIICTL register (address 0x0032). When RGMII mode is disabled, the DP83867 operates in GMII mode.

## Device Functional Modes (continued)

RGMIIE ENABLE (Register 0x0032, bit 7)	DEVICE FUNCTIONAL MODE
0x1	RGMIIE
0x0	GMII

The initial strap value for the RGMIIE disable is also available in the Strap Configuration Status Register 1 (STRAP\_STS1).

### 8.4.1.1 Reduced GMII (RGMIIE)

The Reduced Gigabit Media Independent Interface (RGMIIE) is designed to reduce the number of pins required to interconnect the MAC and PHY (12 pins for RGMIIE relative to 24 pins for GMII). To accomplish this goal, the data paths and all associated control signals are reduced and are multiplexed. Both rising and trailing edges of the clock are used. For Gigabit operation the GTX\_CLK and RX\_CLK clocks are 125 MHz, and for 10- and 100-Mbps operation, the clock frequencies are 2.5 MHz and 25 MHz, respectively.

For more information about RGMIIE timing, see the [RGMIIE Interface Timing Budgets](#) application report (SNLA243).

#### 8.4.1.1.1 1000-Mbps Mode Operation

All RGMIIE signals are positive logic. The 8-bit data is multiplexed by taking advantage of both clock edges. The lower 4 bits are latched on the positive clock edge and the upper 4 bits are latched on trailing clock edge. The control signals are multiplexed into a single clock cycle using the same technique.

To reduce power consumption of RGMIIE interface, TXEN\_ER and RXDV\_ER are encoded in a manner that minimizes transitions during normal network operation. This is done by following encoding method. Note that the value of GMII\_TX\_ER and GMII\_TX\_EN are valid at the rising edge of the clock. In RGMIIE mode, GMII\_TX\_ER is presented on TX\_CTRL at the falling edge of the GTX\_CLK clock. RX\_CTRL coding is implemented the same fashion.

When receiving a valid frame with no error, *RX\_CTRL = True* is generated as a logic high on the rising edge of RX\_CLK and *RX\_CTRL = False* is generated as a logic high at the falling edge of RX\_CLK. When no frame is being received, *RX\_CTRL = False* is generated as a logic low on the rising edge of RX\_CLK and *RX\_CTRL = False* is generated as a logic low on the falling edge of RX\_CLK.

TX\_CTRL is treated in a similar manner. During normal frame transmission, the signal stays at a logic high for both edges of GTX\_CLK and during the period between frames where no error is indicated, the signal stays low for both edges.

#### 8.4.1.1.2 1000-Mbps Mode Timing

The DP83867 provides configurable clock skew for the GTX\_CLK and RX\_CLK to optimize timing across the interface. The transmit and receive paths can be optimized independently. Both the transmit and receive path support 16 programmable RGMIIE delay modes via register configuration.

The timing paths can either be configured for Aligned mode or Shift mode. In Aligned mode, no clock skew is introduced. In Shift mode, the clock skew can be introduced in 0.25 ns increments (via register configuration). Configuration of the Aligned mode or Shift mode is accomplished via the RGMIIE Control Register (RGMIICTL), address 0x0032. In Shift mode, the clock skew can be adjusted using the RGMIIE Delay Control Register (RGMIIIDCTL), address 0x0086.

#### 8.4.1.1.3 10- and 100-Mbps Mode

When the RGMIIE interface is operating in the 100-Mbps mode, the Ethernet Media Independent Interface (MII) is implemented by reducing the clock rate to 25 MHz. For 10-Mbps operation, the clock is further reduced to 2.5 MHz. In the RGMIIE 10/100 mode, the transmit clock RGMIIE TX\_CLK is generated by the MAC and the receive clock RGMIIE RX\_CLK is generated by the PHY. During the packet receiving operation, the RGMIIE RX\_CLK may be stretched on either the positive or negative pulse to accommodate the transition from the free-running clock to a data synchronous clock domain. When the speed of the PHY changes, a similar stretching of the positive or negative pulses is allowed. No glitch is allowed on the clock signals during clock speed transitions.

This interface operates at 10- and 100-Mbps speeds the same way it does at 1000-Mbps mode with the exception that the data may be duplicated on the falling edge of the appropriate clock.

The MAC holds the RGMII TX\_CLK low until it has ensured that it is operating at the same speed as the PHY.

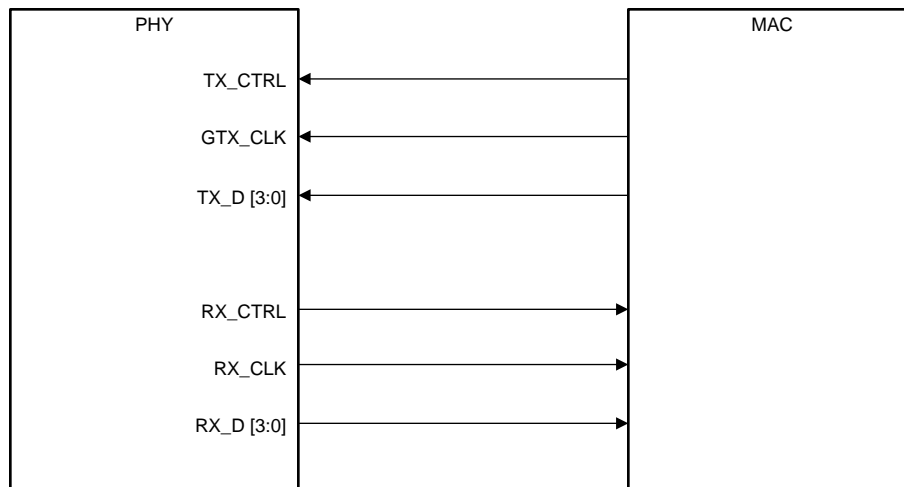

**Figure 18. RGMII Connections**

#### 8.4.1.2 Gigabit MII (GMII)

The Gigabit Media Independent Interface (GMII) is the IEEE defined interface for use between an Ethernet PHY and an Ethernet MAC. GMII is available on the PAP devices only. The purpose of GMII is to make various physical media transparent to the MAC layer. The GMII Interface accepts either GMII or MII data, control and status signals and routes them either to the 1000BASE-T, 100BASE-TX, or 10BASE-T<sub>e</sub> modules, respectively.

The GMII interface has the following characteristics:

- Supports 10/100/1000 Mbps operation
- Data and delimiters are synchronous to clock references
- Provides independent 8-bit wide transmit and receive data paths
- Provides a simple management interface
- Provides for Full-Duplex operation

The GMII interface is defined in IEEE 802.3 Clause 35. In each direction of data transfer, there are Data (an eight-bit bundle), Delimiter, Error, and Clock signals. GMII signals are defined such that an implementation may multiplex most GMII signals with the similar PCS service interface defined in IEEE 802.3 Clause 22. Two media status signals are provided. One indicates the presence of carrier (CRS), and the other indicates the occurrence of a collision (COL). The MII signal names have been retained and the functions of most signals are the same, but additional valid combinations of signals have been defined for 1000 Mbps operation.

The connection diagram for GMII is shown in [Figure 19](#).

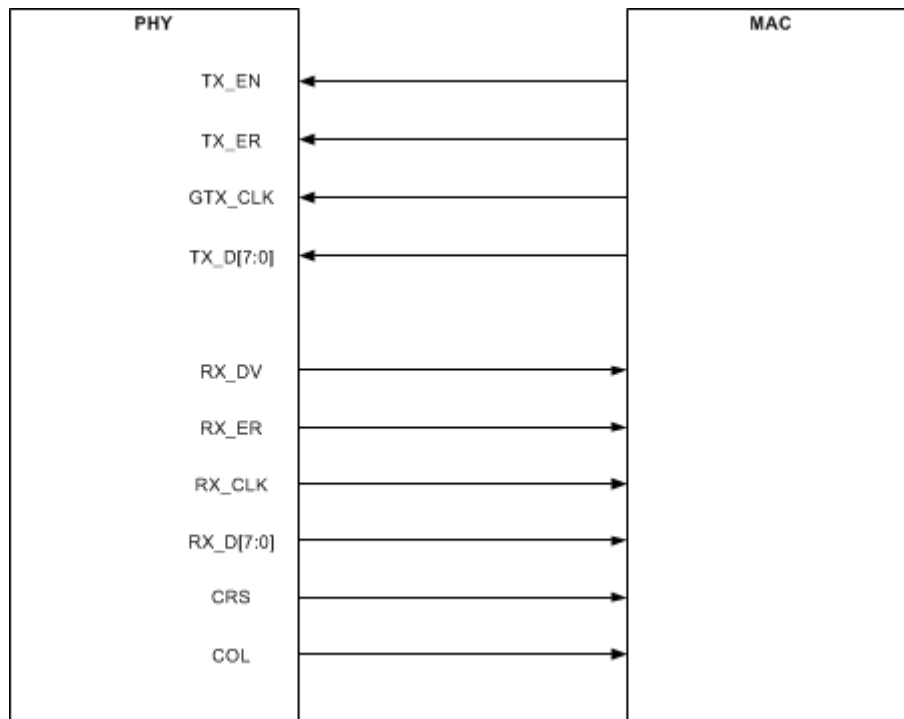

Figure 19. GMII Connections

#### 8.4.1.3 Media Independent Interface (MII)

MII connections are used for 10/100 data. MII is compatible with GMII and will be used for 10/100 data when the device is configured for GMII. MII is available on PAP devices only.

The DP83867 incorporates the Media Independent Interface (MII) as specified in Clause 22 of the IEEE 802.3 standard. This interface may be used to connect PHY devices to a MAC in 10/100 Mbps systems. This section describes the nibble wide MII data interface.

The nibble wide MII data interface consists of a receive bus and a transmit bus each with control signals to facilitate data transfer between the PHY and the upper layer (MAC).

##### 8.4.1.3.1 Nibble-wide MII Data Interface

Clause 22 of the IEEE 802.3 specification defines the Media Independent Interface. This interface includes a dedicated receive bus and a dedicated transmit bus. These two data buses, along with various control and status signals, allow for the simultaneous exchange of data between the DP83867 and the upper layer agent (MAC).

The receive interface consists of a nibble wide data bus RXD[3:0], a receive error signal RX\_ER, a receive data valid flag RX\_DV, and a receive clock RX\_CLK for synchronous transfer of the data. The receive clock operates at either 2.5 MHz to support 10 Mbps operation modes or at 25 MHz to support 100 Mbps operational modes.

The transmit interface consists of a nibble wide data bus TXD[3:0], a transmit enable control signal TX\_EN, and a transmit clock TX\_CLK which runs at either 2.5 MHz or 25 MHz. Additionally, the MII includes the carrier sense signal CRS, as well as a collision detect signal COL. The CRS signal asserts to indicate the reception of data from the network or as a function of transmit data in Half-Duplex mode. The COL signal asserts as an indication of a collision which can occur during Half-Duplex operation when both a transmit and receive operation occur simultaneously.

#### 8.4.1.3.2 Collision Detect

When in Half-Duplex mode, a 10BASE-Te or 100BASE-TX collision is detected when the receive and transmit channels are active simultaneously. Collisions are reported by the COL signal on the MII.

The COL signal remains set for the duration of the collision. If the PHY is receiving when a collision is detected, it is reported immediately (through the COL pin).

Collision is not indicated during Full-Duplex operation.

#### 8.4.1.3.3 Carrier Sense

In 10 Mbps operation, Carrier Sense (CRS) is asserted due to receive activity once valid data is detected via the squelch function. During 100 Mbps operation CRS is asserted when a valid link (SD) and two non-contiguous zeros are detected on the line.

For 10 or 100 Mbps Half-Duplex operation, CRS is asserted during either packet transmission or reception.

For 10 or 100 Mbps Full-Duplex operation, CRS is asserted only due to receive activity.

CRS is deasserted following an end of packet.

The connection diagram for MII is shown in [Figure 20](#).

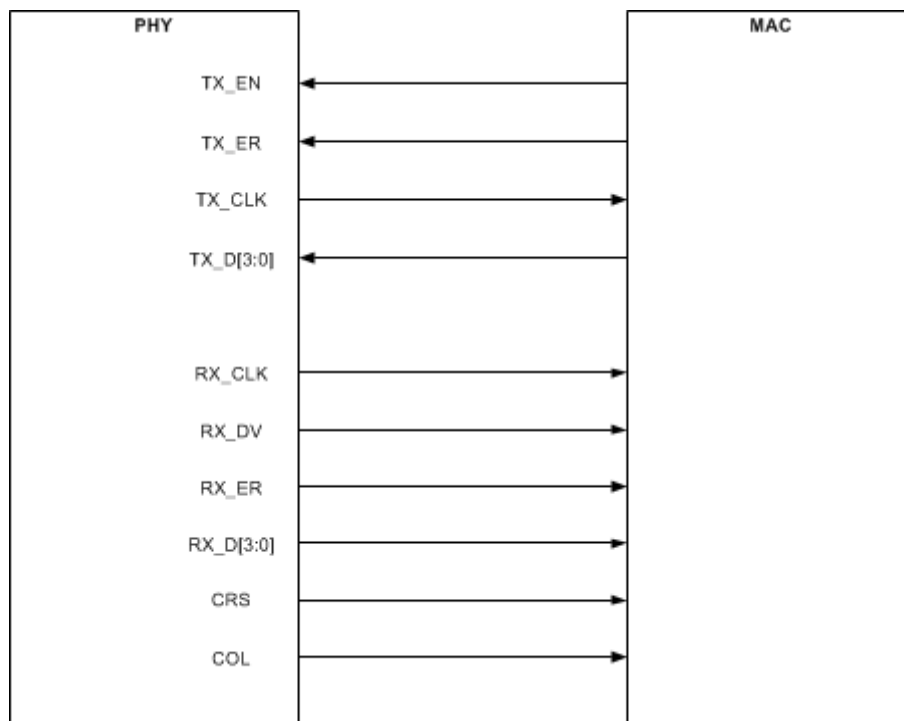

**Figure 20. MII Connections**

#### 8.4.2 Serial Management Interface

The Serial Management Interface (SMI), provides access to the DP83867 internal register space for status information and configuration. The SMI is compatible with IEEE 802.3-2002 clause 22. The implemented register set consists of the registers required by the IEEE 802.3, plus several others to provide additional visibility and controllability of the DP83867 device.

The SMI includes the MDC management clock input and the management MDIO data pin. The MDC clock is sourced by the external management entity, also called Station (STA), and can run at a maximum clock rate of 25 MHz. MDC is not expected to be continuous, and can be turned off by the external management entity when the bus is idle.

The MDIO is sourced by the external management entity and by the PHY. The data on the MDIO pin is latched on the rising edge of the MDC clock. The MDIO pin requires a pullup resistor (2.2 kΩ) which, during IDLE and turnaround, pulls MDIO high.

Up to 32 PHYs can share a common SMI bus. To distinguish between the PHYs, a 5-bit address is used. During power-up reset, the DP83867 latches the PHY\_ADD configuration pins to determine its address.

The management entity must not start an SMI transaction in the first cycle after power-up reset. To maintain valid operation, the SMI bus must remain inactive at least one MDC cycle after hard reset is deasserted. In normal MDIO transactions, the register address is taken directly from the management-frame reg\_addr field, thus allowing direct access to 32 16-bit registers (including those defined in IEEE 802.3 and vendor specific). The data field is used for both reading and writing. The Start code is indicated by a <01> pattern. This pattern makes sure that the MDIO line transitions from the default idle line state. Turnaround is defined as an idle bit time inserted between the Register Address field and the Data field. To avoid contention during a read transaction, no device may actively drive the MDIO signal during the first bit of turnaround. The addressed DP83867 drives the MDIO with a zero for the second bit of turnaround and follows this with the required data. Figure 21 shows the timing relationship between MDC and the MDIO as driven and received by the Station (STA) and the DP83867 (PHY) for a typical register read access.

For write transactions, the station-management entity writes data to the addressed DP83867, thus eliminating the requirement for MDIO turnaround. The turnaround time is filled by the management entity by inserting <10>. Figure 21 shows the timing relationship for a typical MII register write access. The frame structure and general read and write transactions are shown in Table 2, Figure 21, and Figure 22.

Table 2. Typical MDIO Frame Format

TYPICAL MDIO FRAME FORMAT	<idle><start><op code><device addr><reg addr><turnaround><data><idle>
Read Operation	<idle><01><10><AAAA><RRRR><Z0><xxxx xxxx xxxx xxx><idle>
Write Operation	<idle><01<01><AAAA><RRRR><10><xxxx xxxx xxxx xxx><idle>

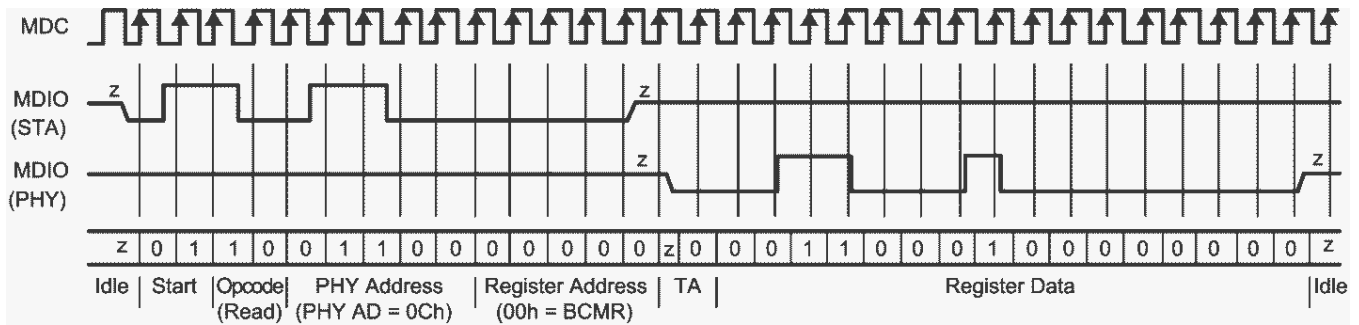

Figure 21. Typical MDC/MDIO Read Operation

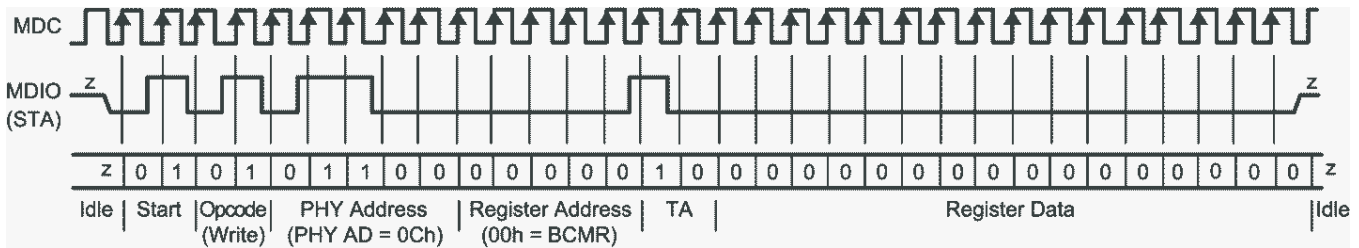

Figure 22. Typical MDC/MDIO Write Operation

#### 8.4.2.1 Extended Address Space Access

The DP83867 SMI function supports read or write access to the extended register set using registers REGCR (0x000Dh) and ADDAR (0x000Eh) and the MDIO Manageable Device (MMD) indirect method defined in IEEE 802.3ah Draft for clause 22 for accessing the clause 45 extended register set.

The standard register set, MDIO registers 0 to 31, is accessed using the normal direct-MDIO access or the indirect method, except for register REGCR (0x000Dh) and ADDAR (0x000Eh) which is accessed only using the normal MDIO transaction. The SMI function ignores indirect accesses to these registers.

REGCR (0x000Dh) is the MDIO Manageable MMD access control. In general, register REGCR(4:0) is the device address DEVAD that directs any accesses of ADDAR (0x000Eh) register to the appropriate MMD.

The DP83867 supports one MMD device address. The vendor-specific device address DEVAD[4:0] = 11111 is used for general MMD register accesses.

All accesses through registers REGCR and ADDAR must use the correct DEVAD. Transactions with other DEVAD are ignored. REGCR[15:14] holds the access function: address (00), data with no post increment (01), data with post increment on read and writes (10) and data with post increment on writes only (11).

- ADDAR is the address and data MMD register. ADDAR is used in conjunction with REGCR to provide the access to the extended register set. If register REGCR[15:1] is 00, then ADDAR holds the address of the extended address space register. Otherwise, ADDAR holds the data as indicated by the contents of its address register. When REGCR[15:14] is set to 00, accesses to register ADDAR modify the extended register set address register. This address register must always be initialized to access any of the registers within the extended register set.
- When REGCR[15:14] is set to 01, accesses to register ADDAR access the register within the extended register set selected by the value in the address register.
- When REGCR[15:14] is set to 10, access to register ADDAR access the register within the extended register set selected by the value in the address register. After that access is complete, for both reads and writes, the value in the address register is incremented.
- When REGCR[15:14] is set to 11, access to register ADDAR access the register within the extended register set selected by the value in the address register. After that access is complete, for write accesses only, the value in the address register is incremented. For read accesses, the value of the address register remains unchanged.

The following sections describe how to perform operations on the extended register set using register REGCR and ADDAR. The descriptions use the device address for general MMD register accesses (DEVAD[4:0] = 11111).

#### 8.4.2.1.1 Write Address Operation

1. Write the value 0x001F (address function field = 00, DEVAD = 31) to register REGCR.
2. Write the desired register address to register ADDAR.

Subsequent writes to register ADDAR (step 2) continue to write the address register.

#### 8.4.2.1.2 Read Address Operation

To read the address register:

1. Write the value 0x001F (address function field = 00, DEVAD = 31) to register REGCR.
2. Read the register address from register ADDAR.

#### 8.4.2.1.3 Write (No Post Increment) Operation

To write a register in the extended register set:

1. Write the value 0x001F (address function field = 00, DEVAD = 31) to register REGCR.
2. Write the desired register address to register ADDAR.
3. Write the value 0x401F (data, no post increment function field = 01, DEVAD = 31) to register REGCR.
4. Write the content of the desired extended register set register to register ADDAR.

Subsequent writes to register ADDAR (step 4) continue to rewrite the register selected by the value in the address register.

**Note:** steps (1) and (2) can be skipped if the address register was previously configured.

#### 8.4.2.1.4 Read (No Post Increment) Operation

To read a register in the extended register set:

1. Write the value 0x001F (address function field = 00, DEVAD = 31) to register REGCR.
2. Write the desired register address to register ADDAR.
3. Write the value 0x401F (data, no post increment function field = 01, DEVAD = 31) to register REGCR.
4. Read the content of the desired extended register set register to register ADDAR.

Subsequent reads from register ADDAR (step 4) continue reading the register selected by the value in the address register.

**Note:** steps (1) and (2) can be skipped if the address register was previously configured.

#### 8.4.2.1.5 Write (Post Increment) Operation

1. Write the value 0x001F (address function field = 00, DEVAD = 31) to register REGCR.
2. Write the register address from register ADDAR.
3. Write the value 0x801F (data, post increment on reads and writes function field = 10, DEVAD = 31) or the value 0xC01F (data, post increment on writes function field = 11, DEVAD = 31) to register REGCR.
4. Write the content of the desired extended register set register to register ADDAR.

Subsequent writes to register ADDAR (step 4) write the next higher addressed data register selected by the value of the address register; the address register is incremented after each access.

#### 8.4.2.1.6 Read (Post Increment) Operation

To read a register in the extended register set and automatically increment the address register to the next higher value following the write operation:

1. Write the value 0x001F (address function field = 00, DEVAD = 31) to register REGCR.
2. Write the desired register address to register ADDAR.
3. Write the value 0x801F (data, post increment on reads and writes function field = 10, DEVAD = 31) to register REGCR.
4. Read the content of the desired extended register set register to register ADDAR.

Subsequent reads to register ADDAR (step 4) read the next higher addressed data register selected by the value of the address register; the address register is incremented after each access.

#### 8.4.2.1.7 Example of Read Operation Using Indirect Register Access

Read register 0x0170.

1. Write register 0x0D to value 0x001F.
2. Write register 0x0E to value 0x0170
3. Write register 0x0D to value 0x401F.
4. Read register 0x0E.

The expected default value is 0x0C10.

#### 8.4.2.1.8 Example of Write Operation Using Indirect Register Access

Write register 0x0170 to value 0x0C50.

1. Write register 0x0D to value 0x001F.
2. Write register 0x0E to value 0x0170
3. Write register 0x0D to value 0x401F.
4. Write register 0x0E to value 0x0C50.

This write disables the output clock on the CLK\_OUT pin.

### 8.4.3 Auto-Negotiation

All 1000BASE-T PHYs are required to support Auto-Negotiation. The Auto-Negotiation function in 1000BASE-T has three primary purposes:

- Auto-Negotiation of Speed and Duplex Selection
- Auto-Negotiation of Master or Slave Resolution

- Auto-Negotiation of Pause or Asymmetrical Pause Resolution

#### **8.4.3.1 Speed and Duplex Selection - Priority Resolution**

The Auto-Negotiation function provides a mechanism for exchanging configuration information between the two ends of a link segment. This mechanism is implemented by exchanging Fast Link Pulses (FLP). FLPs are burst pulses that provide the signalling used to communicate the abilities between two devices at each end of a link segment. For further details regarding Auto-Negotiation, refer to Clause 28 of the IEEE 802.3 specification. The DP83867 supports 1000BASE-T, 100BASE-TX, and 100BASE-T modes of operation. The process of Auto-Negotiation ensures that the highest performance protocol is selected (that is, priority resolution) based on the advertised abilities of the Link Partner and the local device.

#### **8.4.3.2 Master and Slave Resolution**

If 1000BASE-T mode is selected during the priority resolution, the second goal of Auto-Negotiation is to resolve Master or Slave configuration. The Master mode priority is given to the device that supports multiport nodes, such as switches and repeaters. Single node devices such as DTE or NIC card takes lower Master mode priority.

#### **8.4.3.3 Pause and Asymmetrical Pause Resolution**

When Full-Duplex operation is selected during priority resolution, the Auto-Negotiation also determines the Flow Control capabilities of the two link partners. Flow control was originally introduced to force a busy station's Link Partner to stop transmitting data in Full-Duplex operation. Unlike Half-Duplex mode of operation where a link partner could be forced to back off by simply generating collisions, the Full-Duplex operation needed a mechanism to slow down transmission from a link partner in the event that the receiving station's buffers are becoming full. A new MAC control layer was added to handle the generation and reception of Pause Frames. Each MAC Controller has to advertise whether it is capable of processing Pause Frames. In addition, the MAC Controller advertises if Pause frames can be handled in both directions, that is, receive and transmit. If the MAC Controller only generates Pause frames but does not respond to Pause frames generated by a link partner, it is called Asymmetrical Pause. The advertisement of Pause and Asymmetrical Pause capabilities is enabled by writing 1 to bits 10 and 11 of ANAR (register address 0x0004). The link partner's Pause capabilities is stored in ANLPAR (register address 0x0005) bits 10 and 11. The MAC Controller has to read from ANLPAR to determine which Pause mode to operate. The PHY layer is not involved in Pause resolution other than simply advertising and reporting of Pause capabilities.

#### **8.4.3.4 Next Page Support**

The DP83867 supports the Auto-Negotiation Next Page protocol as required by IEEE 802.3 clause 28.2.4.1.7. The ANNPTR 0x07 allows for the configuration and transmission of the Next Page. Refer to clause 28 of the IEEE 802.3 standard for detailed information regarding the Auto-Negotiation Next Page function.

#### **8.4.3.5 Parallel Detection**

The DP83867 supports the Parallel Detection function as defined in the IEEE 802.3 specification. Parallel Detection requires the 10/100-Mbps receivers to monitor the receive signal and report link status to the Auto-Negotiation function. Auto-Negotiation uses this information to configure the correct technology in the event that the Link Partner does not support Auto-Negotiation, yet is transmitting link signals that the 10BASE-T or 100BASE-X PMA recognize as valid link signals.

If the DP83867 completes Auto-Negotiation as a result of Parallel Detection, without Next Page operation, bits 5 and 7 of ANLPAR (register address 0x0005) are set to reflect the mode of operation present in the Link Partner. Note that bits 4:0 of the ANLPAR are also set to 00001 based on a successful parallel detection to indicate a valid 802.3 selector field. Software may determine that the negotiation is completed through Parallel Detection by reading 0 in bit 0 of ANER (register address 0x0006) after Auto-Negotiation Complete, bit 5 of BMSR (register address 0x0001), is set. If the PHY is configured for parallel detect mode and any condition other than a good link occurs, the parallel detect fault, bit 4 of ANER (register address 0x0006), sets.

#### 8.4.3.6 Restart Auto-Negotiation

If a link is established by successful Auto-Negotiation and then lost, the Auto-Negotiation process resumes to determine the configuration for the link. This function ensures that a link can be re-established if the cable becomes disconnected and reconnected. After Auto-Negotiation is completed, it may be restarted at any time by writing 1 to bit 9 of the BMCR (register address 0x0000). A restart Auto-Negotiation request from any entity, such as a management agent, causes DP83867 to halt data transmission or link pulse activity until the `break_link_timer` expires. Consequently, the Link Partner goes into link fail mode and the resume Auto-Negotiation. The DP83867 resumes Auto-Negotiation after the `break_link_timer` has expired by transmitting FLP (Fast Link Pulse) bursts.

#### 8.4.3.7 Enabling Auto-Negotiation Through Software

If Auto-Negotiation is disabled by MDIO access, and the user desires to restart Auto-Negotiation, this could be accomplished by software access. Bit 12 of BMCR (register address 0x00) should be cleared and then set for Auto-Negotiation operation to take place.

If Auto-Negotiation is disabled by strap option, Auto-Negotiation can not be reenabled.

#### 8.4.3.8 Auto-Negotiation Complete Time

Parallel detection and Auto-Negotiation typically take 2-3 seconds to complete. In addition, Auto-Negotiation with next page exchange takes approximately 2-3 seconds to complete, depending on the number of next pages exchanged. Refer to Clause 28 of the IEEE 802.3 standard for a full description of the individual timers related to Auto-Negotiation

#### 8.4.3.9 Auto-MDIX Resolution

The DP83867 can determine if a *straight* or *crossover* cable is used to connect to the link partner. It can automatically re-assign channel A and B to establish link with the link partner, (and channel C and D in 100BASE-T mode). Auto-MDIX resolution precedes the actual Auto-Negotiation process that involves exchange of FLPs to advertise capabilities. Automatic MDI/MDIX is described in IEEE 802.3 Clause 40, section 40.8.2. It is not a required implementation for 10BASE-Te and 100BASE-TX.

Auto-MDIX can be enabled or disabled by strap, using the AMDIX Disable strap, or by register configuration, using bit 6 of the PHYCR register (address 0x0010). When Auto-MDIX is disabled, the PMA is forced to either MDI (*straight*) or MDIX (*crossed*). Manual configuration of MDI or MDIX can also be accomplished by strap, using the Force MDI/X strap, or by register configuration, using bit 5 of the PHYCR register.

For 10/100, Auto-MDIX is independent of Auto-Negotiation. Auto-MDIX works in both Auto-Negotiation mode and manual forced speed mode.

### 8.4.4 Loopback Mode

There are several options for Loopback that test and verify various functional blocks within the PHY. Enabling loopback mode allows in-circuit testing of the digital and analog data paths. Generally, the DP83867 may be configured to one of the Near-end loopback modes or to the Far-end (reverse) loopback. MII Loopback is configured using the BMCR (register address 0x0000). All other loopback modes are enabled using the BISCRCR (register address 0x16). Except where otherwise noted, loopback modes are supported for all speeds (10/100/1000) and all MAC interfaces (RGMI and GMII).

The availability of Loopback depends on the operational mode of the PHY. The Link Status in these loopback modes is also affected by the operational mode. [Table 3](#) lists out the availability of Loopback Modes and their corresponding Link Status indication.

**Table 3. Loopback Availability**

LOOPBACK MODE	MAC INTERFACE	1000M		100M		10M	
		AVAILABILITY	LINK STATUS	AVAILABILITY	LINK STATUS	AVAILABILITY	LINK STATUS
MII	GMII/RGMII	Yes	No	Yes	No	Yes	No
PCS	GMII/RGMII	Yes	No	Yes	Yes	No	No
Digital	GMII/RGMII	Yes	Yes	Yes	Yes	Yes	Yes

**Table 3. Loopback Availability (continued)**

LOOPBACK MODE	MAC INTERFACE	1000M		100M		10M	
		AVAILABILITY	LINK STATUS	AVAILABILITY	LINK STATUS	AVAILABILITY	LINK STATUS
Analog	GMII/RGMII	Yes	Yes	Yes	Yes	Yes	Yes
External	GMII/RGMII	No	No	Yes	Yes	Yes	Yes

#### 8.4.4.1 Near-End Loopback

Near-end loopback provides the ability to loop the transmitted data back to the receiver through the digital or analog circuitry. The point at which the signal is looped back is selected using loopback control bits with several options being provided.

When configuring loopback modes, the Loopback Configuration Register (LOOPCR), address 0x00FE, should be set to 0xE720.

To maintain the desired operating mode, Auto-Negotiation should be disabled before selecting the Near-End Loopback mode. This constraint does not apply for external-loopback mode.

Auto-MDIX should be disabled before selecting the Near-End Loopback mode. MDI or MDIX configuration should be manually configured.

##### 8.4.4.1.1 MII Loopback

MI Loopback is the shallowest loop through the PHY. It is a useful test mode to validate communications between the MAC and the PHY. While in MII Loopback mode the data is looped back, and can also be configured through register to transmit onto the media.

##### 8.4.4.1.2 PCS Loopback

PCS Loopback occurs in the PCS layer of the PHY. No signal processing is performed when using PCS Loopback.

##### 8.4.4.1.3 Digital Loopback

Digital Loopback includes the entire digital transmit – receive path. Data is looped back prior to the analog circuitry.

##### 8.4.4.1.4 Analog Loopback

Analog Loopback includes the entire analog transmit-receive path.

#### 8.4.4.2 External Loopback

When operating in 10BASE-T<sub>e</sub> or 100Base-T mode, signals can be looped back at the RJ-45 connector by wiring the transmit pins to the receive pins. Due to the nature of the signaling in 1000Base-T mode, this type of external loopback is not supported. Analog loopback provides a way to loop data back in the analog circuitry when operating in 1000Base-T mode. For proper operation in Analog Loopback mode, attach 100-Ω terminations to the RJ45 connector.

#### 8.4.4.3 Far-End (Reverse) Loopback

Far-end (Reverse) Loopback is a special test mode to allow testing the PHY from the link-partner side. In this mode, data that is received from the link partner passes through the PHY's receiver, is looped back at the MAC interface and is transmitted back to the link partner. While in Reverse Loopback mode, all data signals that come from the MAC are ignored. Through register configuration, data can also be transmitted onto the MAC Interface.

#### 8.4.5 BIST Configuration

The device incorporates an internal PRBS Built-in Self Test (BIST) circuit to accommodate in-circuit testing or diagnostics. The BIST circuit can be used to test the integrity of the transmit and receive data paths. The BIST can be performed using both internal loopback (digital or analog) or external loopback using a cable fixture. The BIST simulates pseudo-random data transfer scenarios in format of real packets and Inter-Packet Gap (IPG) on the lines. The BIST allows full control of the packet lengths and of the IPG.

The BIST is implemented with independent transmit and receive paths, with the transmit block generating a continuous stream of a pseudo-random sequence. The device generates a 15-bit pseudo-random sequence for the BIST. The received data is compared to the generated pseudo-random data by the BIST Linear Feedback Shift Register (LFSR) to determine the BIST pass or fail status. The number of error bytes that the PRBS checker received is stored in the BICSR2 register (0x0072). The status of whether the PRBS checker is locked to the incoming receive bit stream, whether the PRBS has lost sync, and whether the packet generator is busy, can be read from the STS2 register (0x0017h). While the lock and sync indications are required to identify the beginning of proper data reception, for any link failures or data corruption, the best indication is the contents of the error counter in the BICSR2 register (0x0072). The number of received bytes are stored in BICSR1 (0x0071).

The PRBS test can be put in a continuous mode by using bit 14 of the BICSR register (0x0016h). In continuous mode, when one of the PRBS counters reaches the maximum value, the counter starts counting from zero again. Packet transmission can be configured for one of two types, 64 and 1518 bytes, through register bit 13 of the BICSR register (0x0016).

### 8.4.6 Cable Diagnostics

With the vast deployment of Ethernet devices, the need for reliable, comprehensive and user-friendly cable diagnostic tool is more important than ever. The wide variety of cables, topologies, and connectors deployed results in the need to non-intrusively identify and report cable faults. The TI cable-diagnostic unit provides extensive information about cable integrity. The DP83867 offers the following capabilities in its Cable Diagnostic tools kit:

1. Time Domain Reflectometry (TDR)
2. Active Link Cable Diagnostic (ALCD)

#### 8.4.6.1 TDR

The DP83867 uses Time Domain Reflectometry (TDR) to determine the quality of the cables, connectors, and terminations in addition to estimating the cable length. Some of the possible problems that can be diagnosed include opens, shorts, cable impedance mismatch, bad connectors, termination mismatches, cross faults, cross shorts, and any other discontinuities along the cable.

The DP83867 transmits a test pulse of known amplitude (1 V or 2.5 V) down each of the two pairs of an attached cable. The transmitted signal continues down the cable and reflects from each cable imperfection, fault, bad connector, and from the end of the cable itself. After the pulse transmission, the DP83867 measures the return time and amplitude of all these reflected pulses. This technique enables measuring the distance and magnitude (impedance) of non-terminated cables (open or short), discontinuities (bad connectors), improperly-terminated cables, and crossed pairs wires with  $\pm 1$ -m accuracy.

The DP83867 also uses data averaging to reduce noise and improve accuracy. The DP83867 can record up to five reflections within the tested pair. If more than 5 reflections are recorded, the DP83867 saves the first 5 of them. If a cross fault is detected, the TDR saves the first location of the cross fault and up to 4 reflections in the tested channel. The DP83867 TDR can measure cables beyond 100 m in length.

For all TDR measurements, the transformation between time of arrival and physical distance is done by the external host using minor computations (such as multiplication, addition, and lookup tables). The host must know the expected propagation delay of the cable, which depends, among other things, on the cable category (for example, CAT5, CAT5e, or CAT6).

TDR measurement is allowed in the DP83867 in the following scenarios:

- While Link partner is disconnected – cable is unplugged at the other side
- Link partner is connected but remains *quiet* (for example, in power-down mode)
- TDR could be automatically activated when the link fails or is dropped by setting bit 7 of register 0x0009 (CFG1). The results of the TDR run after the link fails are saved in the TDR registers.

Software could read these registers at any time to apply post processing on the TDR results. This mode is designed for cases when the link dropped due to cable disconnections; after link failure, for instance, the line is quiet to allow a proper function of the TDR.

### 8.4.6.2 ALCD

The DP83867 also supports Active Link Cable Diagnostic (ALCD). The ALCD offers a passive method to estimate the cable length during active link. The ALCD uses passive digital signal processing based on adapted data, thus enabling measurement of cable length with an active link partner. The ALCD Cable length measurement accuracy is  $\pm 5$  m for the pair used in the Rx path (due to the passive nature of the test, only the receive path is measured).

### 8.4.6.3 Energy Detect

The energy-detector module provides signal-strength indication in various scenarios. Because it is based on an IIR filter, this robust energy detector has excellent reaction time and reliability. The filter output is compared to predefined thresholds to decide the presence or absence of an incoming signal. The energy detector also implements hysteresis to avoid jittering in signal-detect indication. Additionally, it has fully-programmable thresholds and listening-time periods, enabling shortening of the reaction time if required.

### 8.4.6.4 Fast Link Drop

The DP83867 includes advanced link-down capabilities that support various real-time applications. The link down mechanism is configurable and includes enhanced modes that allow extremely fast reaction times to link drops.

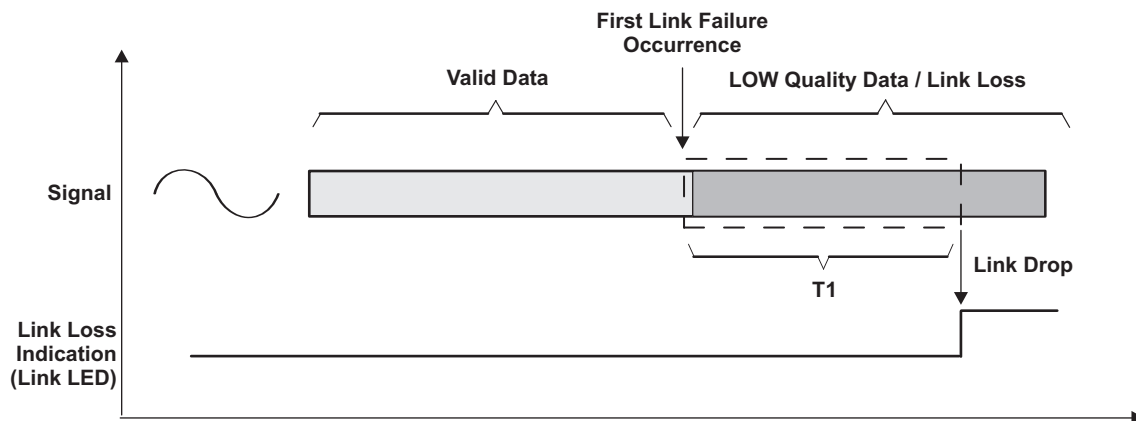

**Figure 23. Fast Link Drop Mechanism**

As described in [Figure 23](#), the link loss mechanism is based on a time window search period in which the signal behavior is monitored. The T1 window is set by default to reduce typical link drops to less than 1 ms in 100-M and 0.5 ms in 1000-M mode.

The DP83867 supports enhanced modes that shorten the window called Fast Link Down mode. In this mode, the T1 window is shortened significantly, in most cases less than 10  $\mu$ s. In this period of time, there are several criteria allowed to generate link loss event and drop the link:

1. Loss of descrambler sync
2. Receive errors
3. MLT3 errors
4. Mean Squared Error (MSE)
5. Energy loss

The Fast Link Down functionality allows the use of each of these options separately or in any combination. Note that because this mode enables extremely quick reaction time, it is more exposed to temporary bad link quality scenarios.

100-M Fast Link Down based on loss of energy can be configured by strap. Other modes require register configuration.

#### 8.4.6.5 Fast Link Detect

Several advanced modes are available for fast link establishment. Unlike the Auto-Negotiation and Auto-MDIX mechanisms defined by the IEEE 802.3 specification, these modes are specific to the DP83867. Take care when implementing these modes. For best operation, TI recommends implementing these modes with a DP83867 on both ends of the link.

These advanced link and crossover modes depend on the speed selected for the link. Some modes are intended for use in 1000Base-T operation. Others are intended for use in 100Base-TX operation.

Fast Link Detect functionality can be configured using the Configuration Register 3 (CFG3), address 0x001E.

#### 8.4.6.6 Speed Optimization

Speed optimization, also known as link downshift, enables fallback to 100-M operation after multiple consecutive failed attempts at Gigabit link establishment. Such a case could occur if cabling with only four wires (two twisted pairs) were connected instead of the standard cabling with eight wires (four twisted pairs).

The number of failed link attempts before falling back to 100-M operation is configurable. By default, four failed link attempts are required before falling back to 100 M.

In enhanced mode, fallback to 100 M can occur after one failed link attempt if energy is not detected on the C and D channels. Speed optimization also supports fallback to 10 M if link establishment fails in Gigabit and in 100-M mode.

Speed optimization can be enabled via strap or through register configuration.

#### 8.4.6.7 Mirror Mode

In some multiport applications, RJ-45 ports may be mirrored relative to one another. This mirroring can require crossing board traces. The DP83867 can resolve this issue by implementing mirroring of the ports inside the device.

In 10/100 operation, the mapping of the port mirroring is:

MDI MODE	MIRROR PORT CONFIGURATION
MDI	A → D
	B → C
MDIX	A → D
	B → C

In Gigabit operation, the mapping of the port mirroring is:

MDI MODE	MIRROR PORT CONFIGURATION
MDI or MDIX	A → D
	B → C
	C → B
	D → A

Mirror mode can be enabled through strap or through register configuration using the Port Mirror Enable bit in the CFG4 register (address 0x0031).

#### 8.4.6.8 Interrupt

The DP83867 can be configured to generate an interrupt when changes of internal status occur. The interrupt allows a MAC to act upon the status in the PHY without polling the PHY registers. The interrupt source can be selected through the interrupt registers, MICR (register address 0x0012) and ISR (register address 0x0013).

#### 8.4.6.9 IEEE 802.3 Test Modes

IEEE 802.3 specification for 1000BASE-T requires that the PHY layer be able to generate certain well defined test patterns on TX outputs. Clause 40 section 40.6.1.1.2 *Test Modes* describes these tests in detail. There are four test modes as well as the normal operation mode. These modes can be selected by writing to the CFG1 register (address 0x0009).

See IEEE 802.3 section 40.6.1.1.2 *Test modes* for more information on the nature of the test modes. The DP83867 provides a test clock synchronous to the IEEE test patterns. The test patterns are output on the MDI pins of the device and the transmit clock is output on the CLK\_OUT pin.

For more information about configuring the DP83867 for IEEE 802.3 compliance testing, see the [How to Configure DP838XX for Ethernet Compliance Testing](#) application report (SNLS239).

## 8.5 Programming

### 8.5.1 Strap Configuration

The DP83867 uses many of the functional pins as strap options to place the device into specific modes of operation. The values of these pins are sampled at power up or hard reset. During software resets, the strap options are internally reloaded from the values sampled at power up or hard reset. The strap option pin assignments are defined below. The functional pin name is indicated in parentheses.

The strap pins supported are 4-level straps, which are described in greater detail below.

#### NOTE

Because strap pins may have alternate functions after reset is deasserted, they should not be connected directly to VDD or GND.

Configuration of the device may be done through the 4-level strap pins or through the management register interface. A pullup resistor and a pulldown resistor of suggested values may be used to set the voltage ratio of the 4-level strap pin input and the supply to select one of the possible selected modes.

The MAC interface pins must support I/O voltages of 3.3 V, 2.5 V, and 1.8 V. As the strap inputs are implemented on these pins, the straps must also support operation at 3.3-V, 2.5-V, and 1.8-V supplies.

For more information about configuring 4-level straps, see the [Configuring Ethernet Devices with 4-Level Straps](#) application report (SNLA258).

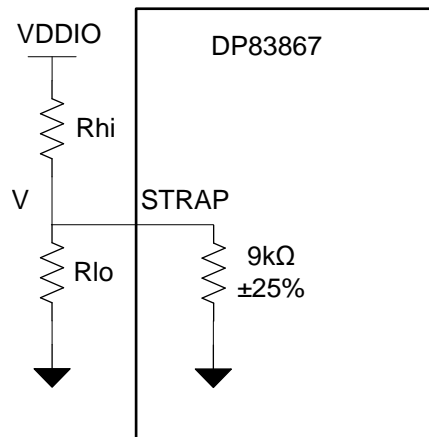

Figure 24. Strap Circuit

Table 4. 4-Level Strap Resistor Ratios

MODE	TARGET VOLTAGE			IDEAL Rhi (kΩ)	IDEAL Rlo (kΩ)
	Vmin (V)	Vtyp (V)	Vmax (V)		
1	0	0	0.098 × VDDIO	OPEN	OPEN
2	0.140 × VDDIO	0.165 × VDDIO	0.191 × VDDIO	10	2.49
3	0.225 × VDDIO	0.255 × VDDIO	0.284 × VDDIO	5.76	2.49
4	0.694 × VDDIO	0.783 × VDDIO	0.888 × VDDIO	2.49	OPEN

All straps have a 9 kΩ ±25% internal pulldown resistor. The voltage at strap pins should be between the Vmin and Vmax mentioned in the *Target Voltage* column in [Table 4](#). Strap resistors with 1% tolerance are recommended.

The following tables describes the DP83867 configuration straps:

**Table 5. 4-Level Strap Pins**

PIN NAME	64 HTQFP PIN #	48 QFN PIN #	DEFAULT	STRAP FUNCTION		
				MODE		
RX_D0	44	33	[00]		PHY_ADD1	PHY_ADD0
				1	0	0
				2	0	1
				3	1	0
				4	1	1
RX_D2	46	35	[00]		PHY_ADD3	PHY_ADD2
				1	0	0
				2	0	1
				3	1	0
				4	1	1
RX_D4	48		[00]		ANEG_SEL1	PHY_ADD4
				1	0	0
				2	0	1
				3	1	0
				4	1	1
RX_D5	49		[00]		Force MDI/X	Half-Duplex Enable (FD/HD)
				1	0	0
				2	0	1
				3	1	0
				4	1	1
RX_D6	50		[00]		RGMIIDisable	AMDIX Disable
				1	0	0
				2	0	1
				3	1	0
				4	1	1
RX_D7	51		[00]		Speed Optimization Enable	Clock Out Disable
				1	0	0
				2	0	1
				3	1	0
				4	1	1
RX_DV/RX_CTRL (Straps Required)	53	38	[0]			Autoneg Disable
				1		N/A
				2		N/A
				3		0
				4		1
CRS	56		[0]			Fast Link Detect (FLD)
				1		0
				2		1
				3		N/A
				4		N/A

**Table 5. 4-Level Strap Pins (continued)**

PIN NAME	64 HTQFP PIN #	48 QFN PIN #	DEFAULT	STRAP FUNCTION		
				MODE	RGMII Clock Skew TX[1]	RGMII Clock Skew TX[0]
LED_2 <sup>(1)</sup>		45	[00]	MODE	RGMII Clock Skew TX[1]	RGMII Clock Skew TX[0]
				1	0	0
				2	0	1
				3	1	0
				4	1	1
LED_1 (RGZ)		46	[00]	MODE	ANEG_SEL	RGMII Clock Skew TX[2]
				1	0	0
				2	0	1
				3	1	0
				4	1	1
LED_1 (PAP)	62		[0]	MODE	ANEG_SEL0	
				1	0	
				2	0	
				3	1	
				4	1	
LED_0	63	47	[0]	MODE	Mirror Enable	
				1	0	
				2	N/A	
				3	1	
				4	N/A	
GPIO_0 <sup>(1)</sup>		39	[00]	MODE	RGMII Clock Skew RX[0]	
				1	0	
				2	Not Applicable	
				3	1	
				4	Not Applicable	
GPIO_1		40	[00]	MODE	RGMII Clock Skew RX[2]	RGMII Clock Skew RX[1]
				1	0	0
				2	0	1
				3	1	0
				4	1	1

(1) NOTE: RGMII TX and RX DLL Skew straps are only available on RGZ devices.

**NOTE**

Strap modes 1 and 2 are not applicable for RX\_DV/RX\_CTRL. The RX\_DV/RX\_CTRL strap must be configured for strap mode 3 or strap mode 4. If the RX\_CTRL pin cannot be strapped to mode 3 or mode 4, bit[7] of Configuration Register 4 (address 0x0031) must be cleared to 0.

**NOTE**

Strap modes 3 and 4 are not applicable for CRS. The CRS strap must be configured for strap mode 1 or strap mode 2.

**NOTE**

Strap modes 2 and 4 are not applicable for LED\_0. The LED\_0 strap must be configured for strap mode 1 or strap mode 3.

**Table 6. PAP Auto-negotiation Select Strap Details**

MODE	ANEG_SELO	ANEG_SEL1	REMARKS
10/100/1000	0	0	advertise ability of 10/100/1000
100/1000	1	0	advertise ability of 100/1000 only
1000	0	1	advertise ability of 1000 only
10/100	1	1	advertise ability of 10/100 only

**Table 7. RGZ Auto-negotiation Select Strap Details**

MODE	ANEG_SEL	REMARKS
10/100/1000	0	advertise ability of 10/100/1000
100/1000	1	advertise ability of 100/1000 only

**Table 8. RGZ RGMII Transmit Clock Skew Details**

MODE	RGMII CLOCK SKEW TX[2]	RGMII CLOCK SKEW TX[1]	RGMII CLOCK SKEW TX[0]	RGMII TX CLOCK SKEW
1	0	0	0	2.0 ns
2	0	0	1	1.5 ns
3	0	1	0	1.0 ns
4	0	1	1	0.5 ns
5	1	0	0	0 ns
6	1	0	1	3.5 ns
7	1	1	0	3.0 ns
8	1	1	1	2.5 ns

**Table 9. RGZ RGMII Receive Clock Skew Details**

MODE	RGMII CLOCK SKEW RX[2]	RGMII CLOCK SKEW RX[1]	RGMII CLOCK SKEW RX[0]	RGMII RX CLOCK SKEW
1	0	0	0	2.0 ns
2	0	0	1	1.5 ns
3	0	1	0	1.0 ns
4	0	1	1	0.5 ns
5	1	0	0	0 ns
6	1	0	1	3.5 ns
7	1	1	0	3.0 ns
8	1	1	1	2.5 ns

## 8.5.2 LED Configuration

The DP83867 supports four configurable Light Emitting Diode (LED) pins: LED\_0, LED\_1, LED\_2, and RXD7/GPIO. Several functions can be multiplexed onto the LEDs for different modes of operation. The LED operation mode can be selected using the LEDCR1 register (address 0x0018).

Because the LED output pins are also used as straps, the external components required for strapping and LED usage must be considered to avoid contention. Specifically, when the LED outputs are used to drive LEDs directly, the active state of each output driver is dependent on the logic level sampled by the corresponding AN input upon power up or reset.

If a given strap input is resistively pulled low then the corresponding output is configured as an active high driver. In the context of the 4-level straps, this occurs for modes 1, 2, and 3. Conversely, if a given strap input is resistively pulled high, then the corresponding output is configured as an active low driver. In the context of the 4-level straps, this occurs only for mode 4.

Refer to [Figure 25](#) for an example of strap connections to external components. In this example, the strapping results in Mode 1 for LED\_0 and Mode 4 for LED\_1.

The adaptive nature of the LED outputs helps to simplify potential implementation issues of these dual purpose pins.

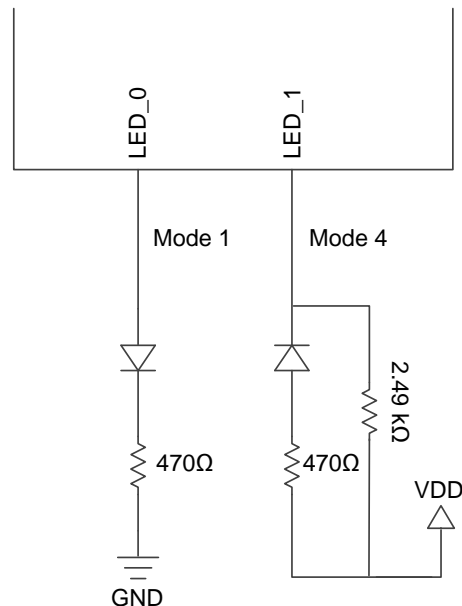
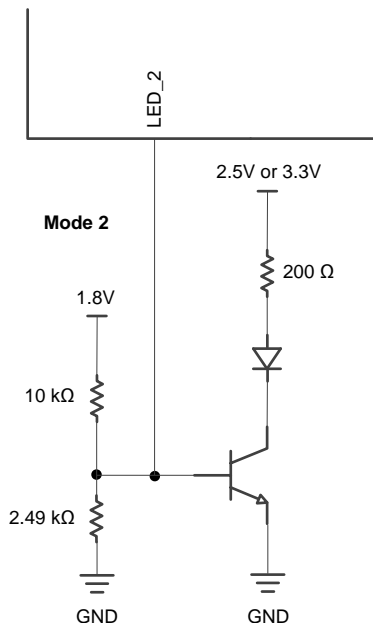

Figure 25. Example Strap Connections

## 8.5.3 LED Operation From 1.8-V I/O VDD Supply

Operation of LEDs from a 1.8-V supply results in dim LED lighting. For best results, the recommendation is to operate from a higher supply (2.5 V or 3.3 V). Refer to [Figure 26](#) for a possible implementation of this functionality.



**Figure 26. LED Operation From 1.8-V I/O VDD Supply**

#### 8.5.4 PHY Address Configuration

The DP83867IRPAP can be set to respond to any of 32 possible PHY addresses via strap pins. DP83867IRRGZ/CRRGZ support 16 addresses. The information is latched into the device at a device power up or hardware reset. Each DP83867 or port sharing an MDIO bus in a system must have a unique physical address. The DP83867IRPAP supports PHY address strapping values 0 (<00000>) through 31 (<11111>). DP83867IRRGZ/CRRGZ support PHY addresses from 0 (<00000>) to 16 (<11111>).

For further detail relating to the latch-in timing requirements of the PHY Address pins, as well as the other hardware configuration pins, refer to [Reset Operation](#).

Based on the default strap configuration of PHY\_ADD[4:0], the DP83867 PHY address will initialize to 0x00 without any external strap configuration.

Refer to [Figure 27](#) for an example of a PHY address connection to external components. In this example, the pins are configured as follows: RX\_D4 = Strap Mode 4, RX\_D2 = Strap Mode 3, and RX\_D0 = Strap Mode 2. Therefore, the PHY address strapping results in address 11001 (19h).

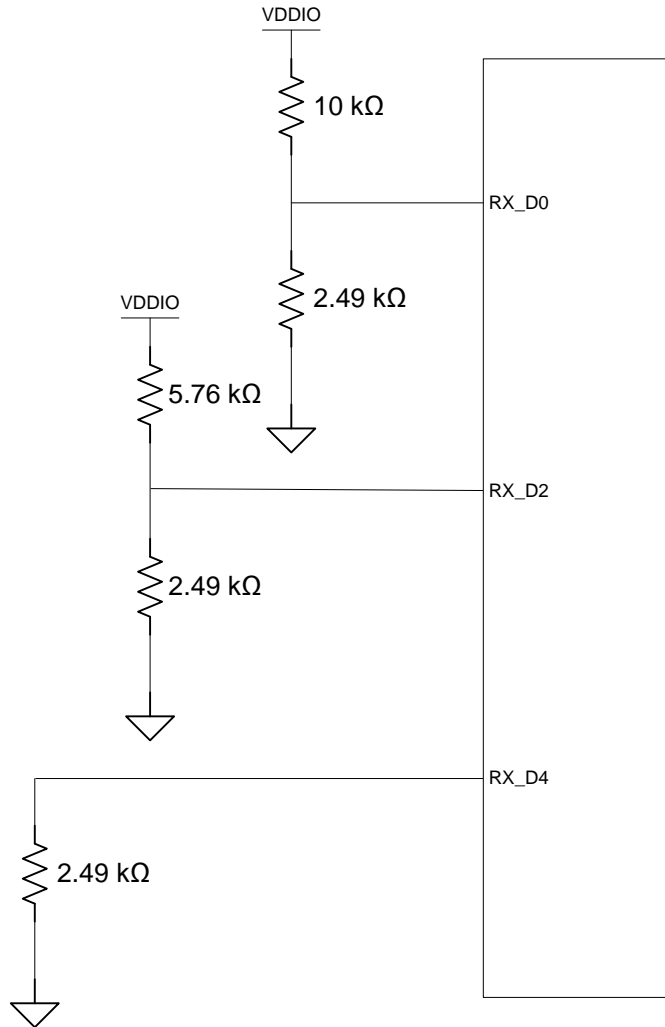

**Figure 27. IRPAP PHY Address Strapping Example**

Refer to [Figure 28](#) for an example of a PHY address connection to external components. In this example, the pins are configured as follows: RX\_D2 = Strap Mode 3 and RX\_D0 = Strap Mode 2. Therefore, the PHY address strapping results in address 1001 (09h).

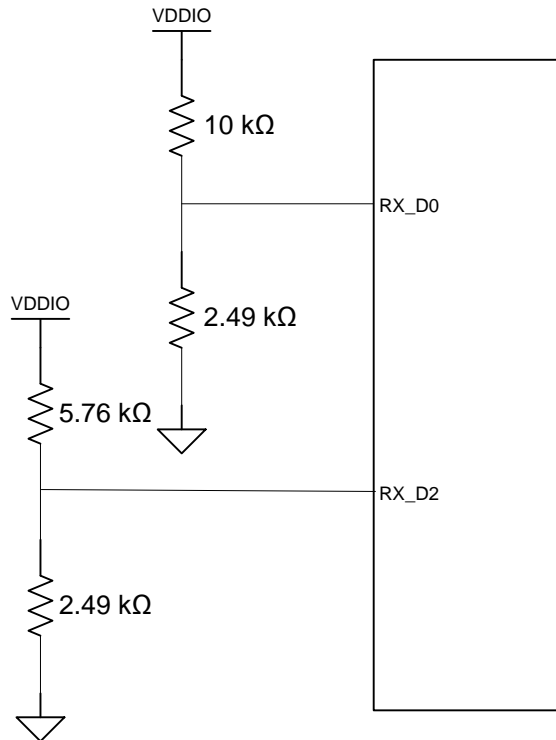

**Figure 28. RGZ PHY Address Strapping Example**

## 8.5.5 Reset Operation

The DP83867 includes an internal power-on-reset (POR) function and therefore does not need to be explicitly reset for normal operation after power up. If required during normal operation, the device can be reset by a hardware or software reset.

### 8.5.5.1 Hardware Reset

A hardware reset is accomplished by applying a low pulse, with a duration of at least 1  $\mu$ s, to the RESET\_N pin. This resets the device such that all registers are reinitialized to default values and the hardware configuration values are re-latched into the device (similar to the power up or reset operation).

### 8.5.5.2 IEEE Software Reset

An IEEE registers software reset is accomplished by setting the reset bit (bit 15) of the BMCR register (address 0x0000). This bit resets the IEEE-defined standard registers.

### 8.5.5.3 Global Software Reset

A global software reset is accomplished by setting bit 15 of register CTRL (address 0x001F) to 1. This bit resets all the internal circuits in the PHY including IEEE-defined registers and all the extended registers. The global software reset resets the device such that all registers are reset to default values and the hardware configuration values are maintained.

### 8.5.5.4 Global Software Restart

A global software restart is accomplished by setting bit 14 of register CTRL (0x001F) to 1. This action resets all the PHY circuits except the registers in the Register File.

## 8.5.6 Power-Saving Modes

DP83867 supports 4 power saving modes. The details are provided below.

### **8.5.6.1 IEEE Power Down**

The PHY is powered down but access to the PHY through MDIO-MDC pins is retained. This mode can be activated by asserting external PWDN pin or by setting bit 11 of BMCR (Register 0x00).

The PHY can be taken out of this mode by a power cycle, software reset, or by clearing the bit 11 in BMCR register. However, the external PWDN pin should be deasserted. If the PWDN pin is kept asserted then the PHY remains in power down.

### **8.5.6.2 Deep Power-Down Mode**

This same as IEEE power down but the XI pad is also turned off. This mode can be activated by asserting the external PWDN pin or by setting bit 11 of BMCR (Register 0x00). Before activating this mode, it is required to set bit 7 for PHYCR (Register 0x10).

The PHY can be taken out of this mode by a power cycle, software reset or by clearing the bit 11 in BMCR register. However, the external PWDN pin should be de-asserted. If the PWDN pin is kept asserted then the PHY remains in power down.

### **8.5.6.3 Active Sleep**

In this mode, all the digital and analog blocks are powered down. The PHY is automatically powered up when a link partner is detected. This mode is useful for saving power when the link partner is down or inactive, but PHY cannot be powered down. In Active Sleep mode, the PHY still routinely sends NLP to the link partner. This mode can be active by writing binary 10 to bits [9:8] for PHYCR (Register 0x10).

### **8.5.6.4 Passive Sleep**

This is just like Active sleep except the PHY does not send NLP. This mode can be activated by writing binary 11 to bits [9:8] PHYCR (Register 0x10).

## 8.6 Register Maps

In the register definitions under the 'Default' heading, the following definitions hold true:

<b>RW</b>	Read Write access
<b>SC</b>	Register sets on event occurrence and Self-Clears when event ends
<b>RW/SC</b>	ReadWrite access/Self Clearing bit
<b>RO</b>	Read Only access
<b>COR</b>	COR = Clear On Read
<b>RO/COR</b>	Read Only, Clear On Read
<b>RO/P</b>	Read Only, Permanently set to a default value
<b>LL</b>	Latched Low and held until read, based upon the occurrence of the corresponding event
<b>LH</b>	Latched High and held until read, based upon the occurrence of the corresponding event

### 8.6.1 Basic Mode Control Register (BMCR)

**Table 10. Basic Mode Control Register (BMCR), Address 0x0000**

BIT	BIT NAME	DEFAULT	DESCRIPTION
15	RESET	0, RW/SC	Reset: 1 = Initiate software Reset / Reset in Process. 0 = Normal operation. This bit, which is self-clearing, returns a value of one until the reset process is complete. The configuration is restrapped.
14	LOOPBACK	0, RW	Loopback: 1 = Loopback enabled. 0 = Normal operation. The loopback function enables MII transmit data to be routed to the MII receive data path. Setting this bit may cause the descrambler to lose synchronization and produce a 500- $\mu$ s dead time before any valid data will appear at the MII receive outputs.
13	SPEED SELECTION LSB	0, RW	Speed Select (Bits 6, 13): When auto-negotiation is disabled writing to this bit allows the port speed to be selected. 11 = Reserved 10 = 1000 Mbps 1 = 100 Mbps 0 = 10 Mbps
12	AUTO-NEGOTIATION ENABLE	Strap, RW	Auto-Negotiation Enable: Strap controls initial value at reset. 1 = Auto-Negotiation Enabled - bits 8 and 13 of this register are ignored when this bit is set. 0 = Auto-Negotiation Disabled - bits 8 and 13 determine the port speed and duplex mode.
11	POWER DOWN	0, RW	Power Down: 1 = Power down. 0 = Normal operation. Setting this bit powers down the PHY. Only the register block is enabled during a power down condition. This bit is OR'd with the input from the PWRDOWN_INT pin. When the active low PWRDOWN_INT pin is asserted, this bit will be set.

**Register Maps (continued)**
**Table 10. Basic Mode Control Register (BMCR), Address 0x0000 (continued)**

BIT	BIT NAME	DEFAULT	DESCRIPTION
10	ISOLATE	0, RW	Isolate: 1 = Isolates the Port from the MII with the exception of the serial management. 0 = Normal operation.
9	RESTART AUTO-NEGOTIATION	0, RW/SC	Restart Auto-Negotiation: 1 = Restart Auto-Negotiation. Reinitiates the Auto-Negotiation process. If Auto-Negotiation is disabled (bit 12 = 0), this bit is ignored. This bit is self-clearing and will return a value of 1 until Auto-Negotiation is initiated, whereupon it will self-clear. Operation of the Auto-Negotiation process is not affected by the management entity clearing this bit. 0 = Normal operation.
8	DUPLEX MODE	Strap, RW	Duplex Mode: When auto-negotiation is disabled writing to this bit allows the port Duplex capability to be selected. 1 = Full Duplex operation. 0 = Half Duplex operation.
7	COLLISION TEST	0, RW	Collision Test: 1 = Collision test enabled. 0 = Normal operation. When set, this bit will cause the COL signal to be asserted in response to the assertion of TX_EN within 512-bit times. The COL signal will be deasserted within 4-bit times in response to the deassertion of TX_EN.
6	SPEED SELECTION MSB	1, RW	Speed Select: See description for bit 13.
5:0	RESERVED	0 0000, RO	RESERVED: Write ignored, read as 0.

## 8.6.2 Basic Mode Status Register (BMSR)

**Table 11. Basic Mode Status Register (BMSR), Address 0x0001**

BIT	BIT NAME	DEFAULT	DESCRIPTION
15	100BASE-T4	0, RO/P	100BASE-T4 Capable: 0 = Device not able to perform 100BASE-T4 mode.
14	100BASE-TX FULL DUPLEX	1, RO/P	100BASE-TX Full Duplex Capable: 1 = Device able to perform 100BASE-TX in full duplex mode.
13	100BASE-TX HALF DUPLEX	1, RO/P	100BASE-TX Half Duplex Capable: 1 = Device able to perform 100BASE-TX in half duplex mode.
12	10BASE-Te FULL DUPLEX	1, RO/P	10BASE-Te Full Duplex Capable: 1 = Device able to perform 10BASE-Te in full duplex mode.
11	10BASE-Te HALF DUPLEX	1, RO/P	10BASE-Te Half Duplex Capable: 1 = Device able to perform 10BASE-Te in half duplex mode.
10	100BASE-T2 FULL DUPLEX	0, RO/P	100BASE-T2 Full Duplex Capable: 0 = Device not able to perform 100BASE-T2 in full duplex mode.
9	100BASE-T2 HALF DUPLEX	0, RO/P	100BASE-T2 Half Duplex Capable: 0 = Device not able to perform 100BASE-T2 in half duplex mode.
8	EXTENDED STATUS	1, RO/P	100BASE-T Extended Status Register: 1 = Device supports Extended Status Register 0x0F.
7	RESERVED	0, RO	RESERVED: Write as 0, read as 0.
6	MF PREAMBLE SUPPRESSION	1, RO/P	Preamble Suppression Capable: 1 = Device able to perform management transaction with preamble suppressed, 32-bits of preamble needed only once after reset, invalid opcode or invalid turnaround. 0 = Normal management operation.
5	AUTO-NEGOTIATION COMPLETE	0, RO	Auto-Negotiation Complete: 1 = Auto-Negotiation process complete. 0 = Auto-Negotiation process not complete.
4	REMOTE FAULT	0, RO/LH	Remote Fault: 1 = Remote Fault condition detected (cleared on read or by reset). Fault criteria: Far-End Fault Indication or notification from Link Partner of Remote Fault. 0 = No remote fault condition detected.
3	AUTO-NEGOTIATION ABILITY	1, RO/P	Auto Negotiation Ability: 1 = Device is able to perform Auto-Negotiation. 0 = Device is not able to perform Auto-Negotiation.
2	LINK STATUS	0, RO/LL	Link Status: 1 = Valid link established. 0 = Link not established. The criteria for link validity is implementation specific. The occurrence of a link failure condition will causes the Link Status bit to clear. Once cleared, this bit may only be set by establishing a good link condition and a read through the management interface.

**Table 11. Basic Mode Status Register (BMSR), Address 0x0001 (continued)**

BIT	BIT NAME	DEFAULT	DESCRIPTION
1	JABBER DETECT	0, RO/LH	Jabber Detect: This bit only has meaning in 10-Mbps mode. 1 = Jabber condition detected. 0 = No Jabber. This bit is implemented with a latching function, such that the occurrence of a jabber condition causes it to set until it is cleared by a read to this register by the management interface or by a reset.
0	EXTENDED CAPABILITY	1, RO/P	Extended Capability: 1 = Extended register capabilities. 0 = Basic register set capabilities only.

### 8.6.3 PHY Identifier Register #1 (PHYIDR1)

The PHY Identifier Registers #1 and #2 together form a unique identifier for the DP83867. The Identifier consists of a concatenation of the Organizationally Unique Identifier (OUI), the vendor's model number and the model revision number. A PHY may return a value of zero in each of the 32 bits of the PHY Identifier if desired. The PHY Identifier is intended to support network management. Texas Instruments' IEEE assigned OUI is 080028h.

**Table 12. PHY Identifier Register #1 (PHYIDR1), Address 0x0002**

BIT	BIT NAME	DEFAULT	DESCRIPTION
15:0	OUI_MSB	0010 0000 0000 0000, RO/P	OUI Most Significant Bits: Bits 3 to 18 of the OUI (080028h,) are stored in bits 15 to 0 of this register. The most significant two bits of the OUI are ignored (the IEEE standard refers to these as bits 1 and 2).

### 8.6.4 PHY Identifier Register #2 (PHYIDR2)

**Table 13. PHY Identifier Register #2 (PHYIDR2), Address 0x0003**

BIT	BIT NAME	DEFAULT	DESCRIPTION
15:10	OUI_LSB	1010 00, RO/P	OUI Least Significant Bits: Bits 19 to 24 of the OUI (080028h) are mapped from bits 15 to 10 of this register respectively.
9:4	VNDR_MDL	10 0011, RO/P	Vendor Model Number: The six bits of vendor model number are mapped from bits 9 to 4 (most significant bit to bit 9).
3:0	MDL_REV	0001, RO/P	Model Revision Number: Four bits of the vendor model revision number are mapped from bits 3 to 0 (most significant bit to bit 3). This field will be incremented for all major device changes.

### 8.6.5 Auto-Negotiation Advertisement Register (ANAR)

This register contains the advertised abilities of this device as they will be transmitted to its link partner during Auto-Negotiation. Any writes to this register prior to completion of Auto-Negotiation (as indicated in the Basic Mode Status Register (address 01h) Auto-Negotiation Complete bit, BMSR[5]) should be followed by a renegotiation. This will ensure that the new values are properly used in the Auto-Negotiation.

**Table 14. Auto-Negotiation Advertisement Register (ANAR), Address 0x0004**

BIT	BIT NAME	DEFAULT	DESCRIPTION
15	NP	0, RW	Next Page Indication: 0 = Next Page Transfer not desired. 1 = Next Page Transfer desired.
14	RESERVED	0, RO/P	RESERVED by IEEE: Writes ignored, Read as 0.
13	RF	0, RW	Remote Fault: 1 = Advertises that this device has detected a Remote Fault. 0 = No Remote Fault detected.
12	RESERVED	0, RW	RESERVED for Future IEEE use: Write as 0, Read as 0
11	ASM_DIR	0, RW	Asymmetric PAUSE Support for Full Duplex Links: The ASM_DIR bit indicates that asymmetric PAUSE is supported. Encoding and resolution of PAUSE bits is defined in IEEE 802.3 Annex 28B, Tables 28B-2 and 28B-3, respectively. Pause resolution status is reported in PHYCR[13:12]. 1 = Advertise that the DTE (MAC) has implemented both the optional MAC control sublayer and the pause function as specified in clause 31 and annex 31B of 802.3u. 0 = No MAC based full duplex flow control.
10	PAUSE	0, RW	PAUSE Support for Full Duplex Links: The PAUSE bit indicates that the device is capable of providing the symmetric PAUSE functions as defined in Annex 31B. Encoding and resolution of PAUSE bits is defined in IEEE 802.3 Annex 28B, Tables 28B-2 and 28B-3, respectively. Pause resolution status is reported in PHYCR[13:12]. 1 = Advertise that the DTE (MAC) has implemented both the optional MAC control sublayer and the pause function as specified in clause 31 and annex 31B of 802.3u. 0 = No MAC based full duplex flow control.
9	T4	0, RO/P	100BASE-T4 Support: 1 = 100BASE-T4 is supported by the local device. 0 = 100BASE-T4 not supported.
8	TX_FD	Strap, RW	100BASE-TX Full Duplex Support: 1 = 100BASE-TX Full Duplex is supported by the local device. 0 = 100BASE-TX Full Duplex not supported.
7	TX	Strap, RW	100BASE-TX Support: 1 = 100BASE-TX is supported by the local device. 0 = 100BASE-TX not supported.
6	10_FD	Strap, RW	10BASE-Te Full Duplex Support: 1 = 10BASE-Te Full Duplex is supported by the local device. 0 = 10BASE-Te Full Duplex not supported.

**Table 14. Auto-Negotiation Advertisement Register (ANAR), Address 0x0004 (continued)**

BIT	BIT NAME	DEFAULT	DESCRIPTION
5	10BASETe_EN	Strap, RW	10BASE-Te Support: 1 = 10BASE-Te is supported by the local device. 0 = 10BASE-Te not supported.
4:0	SELECTOR	0 0001, RW	Protocol Selection Bits: These bits contain the binary encoded protocol selector supported by this port. <00001> indicates that this device supports IEEE 802.3u.

### 8.6.6 Auto-Negotiation Link Partner Ability Register (ANLPAR) (BASE Page)

This register contains the advertised abilities of the Link Partner as received during Auto-Negotiation. The content changes after the successful Auto-Negotiation if Next pages are supported.

**Table 15. Auto-Negotiation Link Partner Ability Register (ANLPAR), Address 0x0005**

BIT	BIT NAME	DEFAULT	DESCRIPTION
15	NP	0, RO	Next Page Indication: 0 = Link Partner does not desire Next Page Transfer. 1 = Link Partner desires Next Page Transfer.
14	ACK	0, RO	Acknowledge: 1 = Link Partner acknowledges reception of the ability data word. 0 = Not acknowledged. The Auto-Negotiation state machine will automatically control this bit based on the incoming FLP bursts.
13	RF	0, RO	Remote Fault: 1 = Remote Fault indicated by Link Partner. 0 = No Remote Fault indicated by Link Partner.
12	RESERVED	0, RO	RESERVED for Future IEEE use: Write as 0, read as 0.
11	ASM_DIR	0, RO	ASYMMETRIC PAUSE: 1 = Asymmetric pause is supported by the Link Partner. 0 = Asymmetric pause is not supported by the Link Partner.
10	PAUSE	0, RO	PAUSE: 1 = Pause function is supported by the Link Partner. 0 = Pause function is not supported by the Link Partner.
9	T4	0, RO	100BASE-T4 Support: 1 = 100BASE-T4 is supported by the Link Partner. 0 = 100BASE-T4 not supported by the Link Partner.
8	TX_FD	0, RO	100BASE-TX Full Duplex Support: 1 = 100BASE-TX Full Duplex is supported by the Link Partner. 0 = 100BASE-TX Full Duplex not supported by the Link Partner.
7	TX	0, RO	100BASE-TX Support: 1 = 100BASE-TX is supported by the Link Partner. 0 = 100BASE-TX not supported by the Link Partner.
6	10_FD	0, RO	10BASE-Te Full Duplex Support: 1 = 10BASE-Te Full Duplex is supported by the Link Partner. 0 = 10BASE-Te Full Duplex not supported by the Link Partner.
5	10	0, RO	10BASE-Te Support: 1 = 10BASE-Te is supported by the Link Partner. 0 = 10BASE-Te not supported by the Link Partner.
4:0	SELECTOR	0 0000, RO	Protocol Selection Bits: Link Partner's binary encoded protocol selector.

### 8.6.7 Auto-Negotiate Expansion Register (ANER)

This register contains additional Local Device and Link Partner status information.

**Table 16. Auto-Negotiate Expansion Register (ANER), Address 0x0006**

BIT	BIT NAME	DEFAULT	DESCRIPTION
15:7	RESERVED	0, RO	RESERVED: Writes ignored, Read as 0.
6	RX_NEXT_PAGE_LOC_ABLE	1, RO	Receive Next Page Location Able: 1 = Received Next Page storage location is specified by bit 6.5. 0 = Received Next Page storage location is not specified by bit 6.5.
5	RX_NEXT_PAGE_STOR_LOC	1, RO	Receive Next Page Storage Location: 1 = Link Partner Next Pages are stored in register 8. 0 = Link Partner Next Pages are stored in register 5.
4	PDF	0, RO	Parallel Detection Fault: 1 = A fault has been detected via the Parallel Detection function. 0 = A fault has not been detected.
3	LP_NP_ABLE	0, RO	Link Partner Next Page Able: 1 = Link Partner does support Next Page. 0 = Link Partner does not support Next Page.
2	NP_ABLE	1, RO/P	Next Page Able: 1 = Indicates local device is able to send additional Next Pages.
1	PAGE_RX	0, RO/COR	Link Code Word Page Received: 1 = Link Code Word has been received, cleared on a read. 0 = Link Code Word has not been received.
0	LP_AN_ABLE	0, RO	Link Partner Auto-Negotiation Able: 1 = Indicates that the Link Partner supports Auto-Negotiation. 0 = Indicates that the Link Partner does not support Auto-Negotiation.

### 8.6.8 Auto-Negotiation Next Page Transmit Register (ANNPTR)

This register contains the next page information sent by this device to its Link Partner during Auto-Negotiation.

**Table 17. Auto-Negotiation Next Page Transmit Register (ANNPTR), Address 0x0007**

BIT	BIT NAME	DEFAULT	DESCRIPTION
15	NP	0, RW	Next Page Indication: 0 = No other Next Page Transfer desired. 1 = Another Next Page desired.
14	ACK	0, RO	Acknowledge: 1 = Acknowledge reception of link code word 0 = Do not acknowledge of link code word.
13	MP	1, RW	Message Page: 1 = Current page is a Message Page. 0 = Current page is an Unformatted Page.
12	ACK2	0, RW	Acknowledge2: 1 = Will comply with message. 0 = Cannot comply with message. Acknowledge2 is used by the next page function to indicate that Local Device has the ability to comply with the message received.
11	TOG_TX	0, RO	Toggle: 1 = Value of toggle bit in previously transmitted Link Code Word was 0. 0 = Value of toggle bit in previously transmitted Link Code Word was 1. Toggle is used by the Arbitration function within Auto-Negotiation to ensure synchronization with the Link Partner during Next Page exchange. This bit shall always take the opposite value of the Toggle bit in the previously exchanged Link Code Word.
10:0	CODE	000 0000 0001, RW	Code: This field represents the code field of the next page transmission. If the MP bit is set (bit 13 of this register), then the code shall be interpreted as a "Message Page", as defined in Annex 28C of IEEE 802.3u. Otherwise, the code shall be interpreted as an "Unformatted Page", and the interpretation is application specific. The default value of the CODE represents a Null Page as defined in Annex 28C of IEEE 802.3u.

### 8.6.9 Auto-Negotiation Next Page Receive Register (ANNPRR)

This register contains the next page information sent by the Link Partner during Auto-Negotiation.

**Table 18. Auto-Negotiation Next Page Transmit Register (ANNPTR), Address 0x0008**

BIT	BIT NAME	DEFAULT	DESCRIPTION
15	NP	0, RW	Next Page Indication: 0 = No other Next Page Transfer desired by the link partner. 1 = Another Next Page desired by the link partner.
14	ACK	0, RO	Acknowledge: 1 = Acknowledge reception of link code word by the link partner. 0 = Link partner does not acknowledge reception of link code word.
13	MP	1, RW	Message Page: 1 = Received page is a Message Page. 0 = Received page is an Unformatted Page.
12	ACK2	0, RW	Acknowledge2: 1 = Link partner sets the ACK2 bit. 0 = Link partner does not set the ACK2 bit. Acknowledge2 is used by the next page function to indicate that link partner has the ability to comply with the message received.
11	TOG_TX	0, RO	Toggle: 1 = Value of toggle bit in previously transmitted Link Code Word was 0. 0 = Value of toggle bit in previously transmitted Link Code Word was 1. Toggle is used by the Arbitration function within Auto-Negotiation to ensure synchronization with the Link Partner during Next Page exchange. This bit shall always take the opposite value of the Toggle bit in the previously exchanged Link Code Word.
10:0	CODE	000 0000 0001, RW	Code: This field represents the code field of the next page transmission. If the MP bit is set (bit 13 of this register), then the code shall be interpreted as a "Message Page", as defined in Annex 28C of IEEE 802.3u. Otherwise, the code shall be interpreted as an "Unformatted Page", and the interpretation is application specific. The default value of the CODE represents a Null Page as defined in Annex 28C of IEEE 802.3u.

**8.6.10 1000BASE-T Configuration Register (CFG1)**
**Table 19. Configuration Register 1 (CFG1), Address 0x0009**

BIT	BIT NAME	DEFAULT	DESCRIPTION
15:13	TEST MODE	000, RW	Test Mode Select: 111 = Test Mode 7 - Repetitive (Pulse, 63 zeros) 110 = Test Mode 6 - Repetitive 0001 sequence 101 = Test Mode 5 - Scrambled MLT3 Idles 100 = Test Mode 4 - Transmit Distortion Test 011 = Test Mode 3 - Transmit Jitter Test (Slave Mode) 010 = Test Mode 2 - Transmit Jitter Test (Master Mode) 001 = Test Mode 1 - Transmit Waveform Test 000 = Normal Mode
12	MASTER / SLAVE MANUAL CONFIGURATION	0, RW	Enable Manual Master / Slave Configuration: 1 = Enable Manual Master/Slave Configuration control. 0 = Disable Manual Master/Slave Configuration control. Using the manual configuration feature may prevent the PHY from establishing link in 1000Base-T mode if a conflict with the link partner's setting exists.
11	MASTER / SLAVE CONFIGURATION VALUE	0, RW	Manual Master / Slave Configuration Value: 1 = Set PHY as MASTER when register 09h bit 12 = 1. 0 = Set PHY as SLAVE when register 09h bit 12 = 1. Using the manual configuration feature may prevent the PHY from establishing link in 1000Base-T mode if a conflict with the link partner's setting exists.
10	PORT TYPE	0, RW	Advertise Device Type: Multi or single port: 1 = Multi-port device. 0 = Single-port device.
9	1000BASE-T FULL DUPLEX	1, RW	Advertise 1000BASE-T Full Duplex Capable: 1 = Advertise 1000Base-T Full Duplex ability. 0 = Do not advertise 1000Base-T Full Duplex ability.
8	1000BASE-T HALF DUPLEX	1, RW	Advertise 1000BASE-T Half Duplex Capable: 1 = Advertise 1000Base-T Half Duplex ability. 0 = Do not advertise 1000Base-T Half Duplex ability.
7	TDR AUTO RUN	0, RW	Automatic TDR on Link Down: 1 = Enable execution of TDR procedure after link down event. 0 = Disable automatic execution of TDR.
6:0	RESERVED	000 0000, RO	RESERVED: Write ignored, read as 0.

### 8.6.11 Status Register 1 (STS1)

**Table 20. Status Register 1 (STS1) Address 0x000A**

BIT	BIT NAME	DEFAULT	DESCRIPTION
15	MASTER / SLAVE CONFIGURATION FAULT	0, RO, LH, COR	Master / Slave Manual Configuration Fault Detected: 1 = Manual Master/Slave Configuration fault detected. 0 = No Manual Master/Slave Configuration fault detected.
14	MASTER / SLAVE CONFIGURATION RESOLUTION	0, RO	Master / Slave Configuration Results: 1 = Configuration resolved to MASTER. 0 = Configuration resolved to SLAVE.
13	LOCAL RECEIVER STATUS	0, RO	Local Receiver Status: 1 = Local receiver is OK. 0 = Local receiver is not OK.
12	REMOTE RECEIVER STATUS	0, RO	Remote Receiver Status: 1 = Remote receiver is OK. 0 = Remote receiver is not OK.
11	1000BASE-T FULL DUPLEX	0, RO	Link Partner 1000BASE-T Full Duplex Capable: 1 = Link Partner capable of 1000Base-T Full Duplex. 0 = Link partner not capable of 1000Base-T Full Duplex.
10	1000BASE-T HALF DUPLEX	0, RO	Link Partner 1000BASE-T Half Duplex Capable: 1 = Link Partner capable of 1000Base-T Half Duplex. 0 = Link partner not capable of 1000Base-T Half Duplex.
9:8	RESERVED	00, RO	RESERVED by IEEE: Writes ignored, read as 0.
7:0	IDLE ERROR COUNTER	0000 0000, RO, COR	1000BASE-T Idle Error Counter

### 8.6.12 Extended Register Addressing

REGCR (0x000D) and ADDAR (0x000E) allow read/write access to the extended register set (addresses above 0x001F) using indirect addressing.

- **REGCR [15:14] = 00:** A write to ADDAR modifies the extended register set address register. This address register must be initialized to access any of the registers within the extended register set.
- **REGCR [15:14] = 01:** A read or write to ADDAR operates on the register within the extended register set selected (pointed to) by the value in the address register. The address register contents (pointer) remain unchanged.
- **REGCR [15:14] = 10:** A read or write to ADDAR operates on the register within the extended register set selected (pointed to) by the value in the address register. After that access is complete, for both reads and writes, the value in the address register is incremented.
- **REGCR [15:14] = 11:** A read or write to ADDAR operates on the register within the extended register set selected (pointed to) by the value in the address register. After that access is complete, for write accesses only, the value in the address register is incremented. For read accesses, the value of the address register remains unchanged.

### 8.6.12.1 Register Control Register (REGCR)

This register is the MDIO Manageable MMD access control. In general, register REGCR (4:0) is the device address DEVAD that directs any accesses of the ADDAR (0x000E) register to the appropriate MMD. REGCR also contains selection bits for auto increment of the data register. This register contains the device address to be written to access the extended registers. Write 0x1F into bits 4:0 of this register. REGCR also contains selection bits (15:14) for the address auto-increment mode of ADDAR.

**Table 21. Register Control Register (REGCR), Address 0x000D**

BIT	BIT NAME	DEFAULT	DESCRIPTION
15:14	Function	0, RW	00 = Address 01 = Data, no post increment 10 = Data, post increment on read and write 11 = Data, post increment on write only
13:5	RESERVED	0, RO	RESERVED: Writes ignored, read as 0.
4:0	DEVAD	0, RW	Device Address: In general, these bits [4:0] are the device address DEVAD that directs any accesses of ADDAR register (0x000E) to the appropriate MMD. Specifically, the DP83867 uses the vendor specific DEVAD [4:0] = 11111 for accesses. All accesses through registers REGCR and ADDAR should use this DEVAD. Transactions with other DEVAD are ignored.

### 8.6.12.2 Address or Data Register (ADDAR)

This register is the address/data MMD register. ADDAR is used in conjunction with REGCR register (0x000D) to provide the access by indirect read/write mechanism to the extended register set.

**Table 22. Address or Data Register (ADDAR) address 0x000E**

BIT	BIT NAME	DEFAULT	DESCRIPTION
15:0	Address / Data	0, RW	If REGCR register 15:14 = 00, holds the MMD DEVAD's address register, otherwise holds the MMD DEVAD's data register

### 8.6.13 1000BASE-T Status Register (1KSCR)

**Table 23. 1000BASE-T Status Register (1KSCR) address 0x000F**

BIT	BIT NAME	DEFAULT	DESCRIPTION
15	1000BASE-X FULL DUPLEX	0, RO/P	1000BASE-X Full Duplex Support: 1 = 1000BASE-X Full Duplex is supported by the local device. 0 = 1000BASE-X Full Duplex is not supported by the local device.
14	1000BASE-X HALF DUPLEX	0, RO/P	1000BASE-X Half Duplex Support: 1 = 1000BASE-X Half Duplex is supported by the local device. 0 = 1000BASE-X Half Duplex is not supported by the local device.
13	1000BASE-T FULL DUPLEX	1, RO/P	1000BASE-T Full Duplex Support: 1 = 1000BASE-T Full Duplex is supported by the local device. 0 = 1000BASE-T Full Duplex is not supported by the local device.
12	1000BASE-T HALF DUPLEX	1, RO/P	1000BASE-T Half Duplex Support: 1 = 1000BASE-T Half Duplex is supported by the local device. 0 = 1000BASE-T Half Duplex is not supported by the local device.
11:0	RESERVED	00, RO	RESERVED by IEEE: Writes ignored, read as 0.

**8.6.14 PHY Control Register (PHYCR)**
**Table 24. PHY Control Register (PHYCR), Address 0x0010**

BIT	BIT NAME	DEFAULT	DESCRIPTION
15:14	TX FIFO Depth	1, RW	TX FIFO Depth: 11 = 8 bytes/nibbles (1000Mbps/Other Speeds) 10 = 6 bytes/nibbles (1000Mbps/Other Speeds) 01 = 4 bytes/nibbles (1000Mbps/Other Speeds) 00 = 3 bytes/nibbles (1000Mbps/Other Speeds) Note: FIFO is enabled only in the following modes: 1000BaseT + GMII
13:11	RESERVED	010, RO	RESERVED
10	FORCE_LINK_GOOD	0, RW	Force Link Good: 1 = Force link good according to the selected speed. 0 = Normal operation
9:8	POWER_SAVE_MODE	0, RW	Power-Saving Modes: 11 = Passive Sleep mode: Power down all digital and analog blocks. 10 = Active Sleep mode: Power down all digital and analog blocks. Automatic power-up is performed when link partner is detected. Link pulses are transmitted approximately once per 1.4 Sec in this mode to wake up any potential link partner. 01 = IEEE mode: power down all digital and analog blocks. Note: If DISABLE_CLK_125 (bit [4] of this register) is set to zero, the PLL is also powered down. 00 = Normal mode
7	DEEP_POWER_DOWN_EN	0, RW	Deep power-down mode enable 1 = When power down is initiated through assertion of the external power-down pin or through the POWER_DOWN bit in the BMCR, the device enters a deep power-down mode. 0 = Normal operation.
6:5	MDI_CROSSOVER	11, RO	MDI Crossover Mode: 1x = Enable automatic crossover 1 = Manual MDI-X configuration 0 = Manual MDI configuration
4	DISABLE_CLK_125	0, RW	Disable 125MHz Clock: This bit may be used in conjunction with POWER_SAVE_MODE (bits 9:8 of this register). 1 = Disable CLK125. 0 = Enable CLK125.
3	RESERVED	1, RO	RESERVED: Writes ignored, read as 1.
2	STANDBY_MODE	0, RW	Standby Mode: 1 = Enable standby mode. Digital and analog circuitry are powered up, but no link can be established. 0 = Normal operation.
1	LINE_DRIVER_INV_EN	0, RW	Line Driver Inversion Enable: 1 = Invert Line Driver Transmission. 0 = Normal operation.
0	DISABLE_JABBER	0, RW	Disable Jabber 1 = Disable Jabber function. 0 = Enable Jabber function.

### 8.6.15 PHY Status Register (PHYSTS)

This register provides a single location within the register set for quick access to commonly accessed information.

**Table 25. PHY Status Register (PHYSTS), Address 0x0011**

BIT	BIT NAME	DEFAULT	DESCRIPTION
15:14	SPEED SELECTION	0, RO	Speed Select Status: These two bits indicate the speed of operation as determined by Auto-Negotiation or as set by manual configuration. 11 = Reserved 10 = 1000 Mbps 01 = 100 Mbps 00 = 10 Mbps
13	DUPLEX MODE	0, RO	Duplex Mode Status: 1 = Full Duplex 0 = Half Duplex.
12	PAGE RECEIVED	0, RO, LH, COR	Page Received: This bit is latched high and will be cleared upon a read. 1 = Page received. 0 = No page received.
11	SPEED DUPLEX RESOLVED	0, RO	Speed Duplex Resolution Status: 1 = Auto-Negotiation has completed or is disabled. 0 = Auto-Negotiation is enabled and has not completed.
10	LINK_STATUS	0, RO	Link Status: 1 = Link is up. 0 = Link is down.
9	MDI_X_MODE_CD	0, RO	MDI/MDIX Resolution Status for C and D Line Driver Pairs: 1 = Resolved as MDIX 0 = Resolved as MDI.
8	MDI_X_MODE_AB	0, RO	MDI/MDIX Resolution Status for A and B Line Driver Pairs: 1 = Resolved as MDIX 0 = Resolved as MDI.
7	SPEED_OPT_STATUS	0, RO	Speed Optimization Status: 1 = Auto-Negotiation is currently being performed with Speed Optimization masking 1000BaseT abilities (Valid only during Auto-Negotiation). 0 = Auto-Negotiation is currently being performed without Speed Optimization.
6	SLEEP_MODE	0, RO	Sleep Mode Status: 1 = Device currently in sleep mode. 0 = Device currently in active mode.
5:2	WIRE_CROSS	0, RO	Crossed Wire Indication: Indicates channel polarity in 1000BASE-T linked status. Bits [5:2] correspond to channels [D,C,B,A], respectively. 1 = Channel polarity is reversed. 0 = Channel polarity is normal.

**Table 25. PHY Status Register (PHYSTS), Address 0x0011 (continued)**

BIT	BIT NAME	DEFAULT	DESCRIPTION
1	POLARITY STATUS	1, RO	10BASE-T <sub>e</sub> Polarity Status: 1 = Correct Polarity detected. 0 = Inverted Polarity detected.
0	JABBER DETECT	0, RO	Jabber Detect: This bit only has meaning in 10 Mbps mode. This bit is a duplicate of the Jabber Detect bit in the BMSR register, except that it is not cleared upon a read of the PHYSTS register. 1 = Jabber condition detected. 0 = No Jabber.

### 8.6.16 MII Interrupt Control Register (MICR)

This register implements the Interrupt PHY Specific Control register. The individual interrupt events must be enabled by setting bits in the MII Interrupt Control Register (MICR). If the corresponding enable bit in the register is set, an interrupt is generated if the event occurs.

**Table 26. MII Interrupt Control Register (MICR), Address 0x0012**

BIT	BIT NAME	DEFAULT	DESCRIPTION
15	AUTONEG_ERR_INT_EN	0, RW	Enable Auto-Negotiation Error Interrupt: 1 = Enable Auto-Negotiation Error interrupt. 0 = Disable Auto-Negotiation Error interrupt.
14	SPEED_CHNG_INT_EN	0, RW	Enable Speed Change Interrupt: 1 = Enable Speed Change interrupt. 0 = Disable Speed Change interrupt.
13	DUPLEX_MODE_CHNG_INT_EN	0, RW	Enable Duplex Mode Change Interrupt: 1 = Enable Duplex Mode Change interrupt. 0 = Disable Duplex Mode Change interrupt.
12	PAGE_RECEIVED_INT_EN	0, RW	Enable Page Received Interrupt: 1 = Enable Page Received Interrupt. 0 = Disable Page Received Interrupt.
11	AUTONEG_COMP_INT_EN	0, RW	Enable Auto-Negotiation Complete Interrupt: 1 = Enable Auto-Negotiation Complete Interrupt. 0 = Disable Auto-Negotiation Complete Interrupt.
10	LINK_STATUS_CHNG_INT_EN	0, RW	Enable Link Status Change Interrupt: 1 = Enable Link Status Change interrupt. 0 = Disable Link Status Change interrupt.
9	RESERVED	0, RO	RESERVED
8	FALSE_CARRIER_INT_EN	0, RW	Enable False Carrier Interrupt: 1 = Enable False Carrier interrupt. 0 = Disable False Carrier interrupt.
7	RESERVED	0, RO	RESERVED
6	MDI_CROSSOVER_CHNG_INT_EN	0, RW	Enable MDI Crossover Change Interrupt: 1 = Enable MDI Crossover Change interrupt. 0 = Disable MDI Crossover Change interrupt.
5	SPEED_OPT_EVENT_INT_EN	0, RW	Enable Speed Optimization Event Interrupt: 1 = Enable Speed Optimization Event Interrupt. 0 = Disable Speed Optimization Event Interrupt.
4	SLEEP_MODE_CHNG_INT_EN	0, RW	Enable Sleep Mode Change Interrupt: 1 = Enable Sleep Mode Change Interrupt. 0 = Disable Sleep Mode Change Interrupt.
3	WOL_INT_EN	0, RW	Enable Wake-on-LAN Interrupt: 1 = Enable Wake-on-LAN Interrupt. 0 = Disable Wake-on-LAN Interrupt.

**Table 26. MII Interrupt Control Register (MICR), Address 0x0012 (continued)**

BIT	BIT NAME	DEFAULT	DESCRIPTION
2	XGMII_ERR_INT_EN	0, RW	Enable xGMII Error Interrupt: 1 = Enable xGMII Error Interrupt. 0 = Disable xGMII Error Interrupt.
1	POLARITY_CHNG_INT_EN	0, RW	Enable Polarity Change Interrupt: 1 = Enable Polarity Change interrupt. 0 = Disable Polarity Change interrupt.
0	JABBER_INT_EN	0, RW	Enable Jabber Interrupt: 1 = Enable Jabber interrupt. 0 = Disable Jabber interrupt.

### 8.6.17 Interrupt Status Register (ISR)

This register contains event status for the interrupt function. If an event has occurred since the last read of this register, the corresponding status bit will be set. The status indications in this register will be set even if the interrupt is not enabled.

**Table 27. Interrupt Status Register (ISR), Address 0x0013**

BIT	BIT NAME	DEFAULT	DESCRIPTION
15	AUTONEG_ERR_INT	0, RO, LH, COR	Auto-Negotiation Error Interrupt: 1 = Auto-Negotiation Error interrupt is pending and is cleared by the current read. 0 = No Auto-Negotiation Error interrupt.
14	SPEED_CHNG_INT	0, RO, LH, COR	Speed Change Interrupt: 1 = Speed Change interrupt is pending and is cleared by the current read. 0 = No Speed Change interrupt.
13	DUPLEX_MODE_CHNG_INT	0, RO, LH, COR	Duplex Mode Change Interrupt: 1 = Duplex Mode Change interrupt is pending and is cleared by the current read. 0 = No Duplex Mode Change interrupt.
12	PAGE_RECEIVED_INT	0, RO, LH, COR	Page Received Interrupt: 1 = Page Received Interrupt is pending and is cleared by the current read. 0 = No Page Received Interrupt is pending.
11	AUTONEG_COMP_INT	0, RO, LH, COR	Auto-Negotiation Complete Interrupt: 1 = Auto-Negotiation Complete Interrupt is pending and is cleared by the current read. 0 = No Auto-Negotiation Complete Interrupt is pending.
10	LINK_STATUS_CHNG_INT	0, RO, LH, COR	Link Status Change Interrupt: 1 = Link Status Change interrupt is pending and is cleared by the current read. 0 = No Link Status Change interrupt is pending.
9	RESERVED	0, RO	RESERVED
8	FALSE_CARRIER_INT	0, RO, LH, COR	False Carrier Interrupt: 1 = False Carrier interrupt is pending and is cleared by the current read. 0 = No False Carrier interrupt is pending.
7	RESERVED	0, RO	RESERVED
6	MDI_CROSSOVER_CHNG_INT	0, RO, LH, COR	MDI Crossover Change Interrupt: 1 = MDI Crossover Change interrupt is pending and is cleared by the current read. 0 = No MDI Crossover Change interrupt is pending.

**Table 27. Interrupt Status Register (ISR), Address 0x0013 (continued)**

BIT	BIT NAME	DEFAULT	DESCRIPTION
5	SPEED_OPT_EVENT_INT	0, RO, LH, COR	Speed Optimization Event Interrupt: 1 = Speed Optimization Event Interrupt is pending and is cleared by the current read. 0 = No Speed Optimization Event Interrupt is pending.
4	SLEEP_MODE_CHNG_INT	0, RO, LH, COR	Sleep Mode Change Interrupt: 1 = Sleep Mode Change Interrupt is pending and is cleared by the current read. 0 = No Sleep Mode Change Interrupt is pending.
3	WOL_INT	0, RO, LH, COR	Wake-on-LAN Interrupt: 1 = Wake-on-LAN Interrupt is pending. 0 = No Wake-on-LAN Interrupt is pending.
2	XGMII_ERR_INT	0, RO, LH, COR	xGMII Error Interrupt: 1 = xGMII Error Interrupt is pending and is cleared by the current read. 0 = No xGMII Error Interrupt is pending.
1	POLARITY_CHNG_INT	0, RO, LH, COR	Polarity Change Interrupt: 1 = Polarity Change interrupt is pending and is cleared by the current read. 0 = No Polarity Change interrupt is pending.
0	JABBER_INT	0, RO, LH, COR	Jabber Interrupt: 1 = Jabber interrupt is pending and is cleared by the current read. 0 = No Jabber interrupt is pending.

### 8.6.18 Configuration Register 2 (CFG2)

**Table 28. Configuration Register 2 (CFG2), Address 0x0014**

BIT	BIT NAME	DEFAULT	DESCRIPTION
15:14	RESERVED	0, RO	RESERVED: Writes ignored, read as 0.
13	INTERRUPT_POLARITY	1, RW	Configure Interrupt Polarity: 1 = Interrupt pin is active low. 0 = Interrupt pin is active high.
12	RESERVED	0, RO	RESERVED
11:10	SPEED_OPT_ATTEMPT_CNT	10, RO	Speed Optimization Attempt Count: Selects the number of 1000BASE-T link establishment attempt failures prior to performing Speed Optimization. 11 = 8 10 = 4 01 = 2 00 = 1
9	SPEED_OPT_EN	0, RW	Speed Optimization Enable: 1 = Enable Speed Optimization. 0 = Disable Speed Optimization.
8	SPEED_OPT_ENHANCED_EN	1, RW	Speed Optimization Enhanced Mode Enable: In enhanced mode, speed is optimized if energy is not detected in channels C and D. 1 = Enable Speed Optimization enhanced mode. 0 = Disable Speed Optimization enhanced mode.
7	RESERVED	0, RO	RESERVED
6	SPEED_OPT_10M_EN	1, RW	Enable Speed Optimization to 10BASE-Te: 1 = Enable speed optimization to 10BASE-Te if link establishment fails in 1000BASE-T and 100BASE-TX . 0 = Disable speed optimization to 10BASE-Te.
5:0	RESERVED	0 0111, RO	RESERVED

### 8.6.19 Receiver Error Counter Register (RECR)

**Table 29. Receiver Error Counter Register (RECR), Address 0x0015**

BIT	BIT NAME	DEFAULT	DESCRIPTION
15:0	RXERCNT[15:0]	0, RO, WSC	RX_ER Counter: Receive error counter. This register saturates at the maximum value of 0xFFFF. It is cleared by dummy write to this register.

### 8.6.20 BIST Control Register (BISCR)

This register is used for Build-In Self Test (BIST) configuration. The BIST functionality provides Pseudo Random Bit Stream (PRBS) mechanism including packet generation generator and checker. Selection of the exact loopback point in the signal chain is also done in this register.

**Table 30. BIST Control Register (BISCR), Address 0x0016**

BIT	BIT NAME	DEFAULT	DESCRIPTION
15	PRBS_COUNT_MODE	0, RW	PRBS Continuous Mode: 1 = Continuous mode enabled. When one of the PRBS counters reaches the maximum value, a pulse is generated and the counter starts counting from zero again. This bit must be set for proper PRBS operation. 0 = PRBS continuous mode disabled. PRBS operation is not supported for this setting.
14	GEN_PRBS_PACKET	0, RW	Generated PRBS Packets: 1 = When the packet generator is enabled, it will generate continuous packets with PRBS data. When the packet generator is disabled, the PRBS checker is still enabled. 0 = When the packet generator is enabled, it will generate a single packet with constant data. PRBS generation and checking is disabled.
13	PACKET_GEN_64BIT_MODE	0, RW	BIST Packet Size: 1 = Transmit 64 byte packets in packet generation mode. 0 = Transmit 1518 byte packets in packet generation mode
12	PACKET_GEN_EN	0, RW	Packet BIST Enable: 1 = Enable packet/PRBS generator 0 = Disable packet/PRBS generator
11:8	RESERVED	0, RO	RESERVED: Writes ignored, read as 0.
7	REV_LOOP_RX_DATA_CTRL	0, RW	Reverse Loopback Receive Data Control: This bit may only be set in Reverse Loopback mode. 1 = Send RX packets to MAC in reverse loop 0 = Suppress RX packets to MAC in reverse loop
6	MII_LOOP_TX_DATA_CTRL	0, RW	MII Loopback Transmit Data Control: This bit may only be set in MII Loopback mode. 1 = Transmit data to MDI in MII loop 0 = Suppress data to MDI in MII loop
5:2	LOOPBACK_MODE	0, RW	Loopback Mode Select: PCS Loopback must be disabled (Bits [1:0] =00) prior to selecting the loopback mode. 1000: Reverse loop 0100: External loop 0010: Analog loop 0001: Digital loop

**Table 30. BIST Control Register (BISCR), Address 0x0016 (continued)**

BIT	BIT NAME	DEFAULT	DESCRIPTION
1:0	PCS_LOOPBACK	0, RW	PCS Loopback Select: When configured for 100Base-TX: 11: Loop after MLT3 encoder (full TX/RX path) 10: Loop after scrambler, before MLT3 encoder 01: Loop before scrambler When configured for 1000Base-T: x1: Loop before 1000Base-T signal processing.

### 8.6.21 Status Register 2 (STS2)

**Table 31. Status Register 2 (STS2), Address 0x0017**

BIT	BIT NAME	DEFAULT	DESCRIPTION
15:12	RESERVED	0, RO	RESERVED: Writes ignored, read as 0.
11	PRBS_LOCK	0, RO	PRBS Lock Status: 1 = PRBS checker is locked to the received byte stream. 0 = PRBS checker is not locked.
10	PRBS_LOCK_LOST	0, RO, LH, COR	PRBS Lock Lost: 1 = PRBS checker has lost lock. 0 = PRBS checker has not lost lock.
9	PKT_GEN_BUSY	0, RO	Packet Generator Busy: 1 = Packet generation is in process. 0 = Packet generation is not in process.
8	SCR_MODE_MASTER_1G	0, RO	Gigabit Master Scramble Mode: 1 = 1G PCS (master) is in legacy encoding mode. 0 = 1G PCS (master) is in normal encoding mode..
7	SCR_MODE_MASTER_1G	0, RO	Gigabit Slave Scramble Mode: 1 = 1G PCS (slave) is in legacy encoding mode. 0 = 1G PCS (slave) is in normal encoding mode..
6	CORE_PWR_MODE	0, RO	Core Power Mode: 1 = Core is in normal power mode. 0 = Core is power-down mode or in sleep mode.
5:0	RESERVED	0, RO	RESERVED: Writes ignored, read as 0.

### 8.6.22 LED Configuration Register 1 (LEDCR1)

This register maps the LED functions to the corresponding pins.

**Table 32. LED Configuration Register 1 (LEDCR1), Address 0x0018**

BIT	BIT NAME	DEFAULT	DESCRIPTION
15:12	LED_GPIO_SEL	RW, 0110	Source of the GPIO LED_3: 1111: Reserved 1110: Receive Error 1101: Receive Error or Transmit Error 1100: RESERVED 1011: Link established, blink for transmit or receive activity 1010: Full duplex 1001: 100/1000BT link established 1000: 10/100BT link established 0111: 10BT link established 0110: 100 BTX link established 0101: 1000BT link established 0100: Collision detected 0011: Receive activity 0010: Transmit activity 0001: Receive or Transmit activity 0000: Link established
11:8	LED_2_SEL	RW, 0001	Source of LED_2: 1111: Reserved 1110: Receive Error 1101: Receive Error or Transmit Error 1100: RESERVED 1011: Link established, blink for transmit or receive activity 1010: Full duplex 1001: 100/1000BT link established 1000: 10/100BT link established 0111: 10BT link established 0110: 100 BTX link established 0101: 1000BT link established 0100: Collision detected 0011: Receive activity 0010: Transmit activity 0001: Receive or Transmit activity 0000: Link established

**Table 32. LED Configuration Register 1 (LEDCR1), Address 0x0018 (continued)**

BIT	BIT NAME	DEFAULT	DESCRIPTION
7:4	LED_1_SEL	RW, 0101	Source of LED_1: 1111: Reserved 1110: Receive Error 1101: Receive Error or Transmit Error 1100: RESERVED 1011: Link established, blink for transmit or receive activity 1010: Full duplex 1001: 100/1000BT link established 1000: 10/100BT link established 0111: 10BT link established 0110: 100 BTX link established 0101: 1000BT link established 0100: Collision detected 0011: Receive activity 0010: Transmit activity 0001: Receive or Transmit activity 0000: Link established
3:0	LED_0_SEL	RW, 0000	Source of LED_0: 1111: Reserved 1110: Receive Error 1101: Receive Error or Transmit Error 1100: RESERVED 1011: Link established, blink for transmit or receive activity 1010: Full duplex 1001: 100/1000BT link established 1000: 10/100BT link established 0111: 10BT link established 0110: 100 BTX link established 0101: 1000BT link established 0100: Collision detected 0011: Receive activity 0010: Transmit activity 0001: Receive or Transmit activity 0000: Link established

### 8.6.23 LED Configuration Register 2 (LEDCR2)

This register provides the ability to directly control any or all LED outputs.

**Table 33. LED Configuration Register 2 (LEDCR2), Address 0x0019**

BIT	BIT NAME	DEFAULT	DESCRIPTION
15	RESERVED	0, RO	RESERVED: Writes ignored, read as 0.
14	LED_GPIO_POLARITY	1, RW	GPIO LED Polarity: 1 = Active high 0 = Active low
13	LED_GPIO_DRV_VAL	0, RW	GPIO LED Drive Value: Value to force on GPIO LED This bit is only valid if enabled through LED_GPIO_DRV_EN.
12	LED_GPIO_DRV_EN	0, RW	GPIO LED Drive Enable: 1 = Force the value of the LED_GPIO_DRV_VAL bit onto the GPIO LED. 0 = Normal operation
11	RESERVED	0, RO	RESERVED: Writes ignored, read as 0.
10	LED_2_POLARITY	1, RW	LED_2 Polarity: 1 = Active high 0 = Active low
9	LED_2_DRV_VAL	0, RW	LED_2 Drive Value: Value to force on LED_2 This bit is only valid if enabled through LED_2_DRV_EN.
8	LED_2_DRV_EN	0, RW	LED_2 Drive Enable: 1 = Force the value of the LED_2_DRV_VAL bit onto LED_2. 0 = Normal operation
7	RESERVED	0, RO	RESERVED: Writes ignored, read as 0.
6	LED_1_POLARITY	1, RW	LED_1 Polarity: 1 = Active high 0 = Active low
5	LED_1_DRV_VAL	0, RW	LED_1 Drive Value: Value to force on LED_1 This bit is only valid if enabled through LED_1_DRV_EN.
4	LED_1_DRV_EN	0, RW	LED_1 Drive Enable: 1 = Force the value of the LED_1_DRV_VAL bit onto LED_1. 0 = Normal operation
3	RESERVED	0, RO	RESERVED: Writes ignored, read as 0.
2	LED_0_POLARITY	1, RW	LED_0 Polarity: 1 = Active high 0 = Active low
1	LED_0_DRV_VAL	0, RW	LED_0 Drive Value: Value to force on LED_0 This bit is only valid if enabled through LED_0_DRV_EN.
0	LED_0_DRV_EN	0, RW	LED_0 Drive Enable: 1 = Force the value of the LED_0_DRV_VAL bit onto LED_0. 0 = Normal operation

### 8.6.24 LED Configuration Register (LEDCR3)

This register controls the LED blink rate and stretching.

**Table 34. LED Configuration Register 3 (LEDCR3), Address 0x001A**

BIT	BIT NAME	DEFAULT	DESCRIPTION
15:3	RESERVED	0, RO	RESERVED: Writes ignored, read as 0.
2	LEDS_BYPASS_STRETCHING	0, RW	Bypass LED Stretching: 1 = Bypass LED Stretching 0 = Normal operation

**Table 34. LED Configuration Register 3 (LEDCR3), Address 0x001A (continued)**

BIT	BIT NAME	DEFAULT	DESCRIPTION
1:0	LEDS_BLINK_RATE	10, RW	LED Blink Rate: 11: 2 Hz (500 ms) 10: 5 Hz (200 ms) 01: 10 Hz (100 ms) 00 = 20 Hz (50 ms)

**8.6.25 Configuration Register 3 (CFG3)**
**Table 35. Configuration Register 3 (CFG3), Address 0x001E**

BIT	BIT NAME	DEFAULT	DESCRIPTION																				
15	Fast Link-Up in Parallel Detect	0, RW	Fast Link-Up in Parallel Detect Mode: 1 = Enable Fast Link-Up time During Parallel Detection 0 = Normal Parallel Detection link establishment In Fast Auto MDI-X this bit is automatically set.																				
14	Fast AN Enable	0, RW	Fast Auto-Negotiation Enable: 1 = Enable Fast Auto-Negotiation mode – The PHY auto-negotiates using Timer setting according to Fast AN Sel bits 0 = Disable Fast Auto-Negotiation mode – The PHY auto-negotiates using normal Timer setting Adjusting these bits reduces the time it takes to Auto-negotiate between two PHYs. Note: When using this option care must be taken to maintain proper operation of the system. While shortening these timer intervals may not cause problems in normal operation, there are certain situations where this may lead to problems.																				
13:12	Fast AN Sel	0, RW	<p>Fast Auto-Negotiation Select bits:</p> <table border="1"> <thead> <tr> <th>Fast AN Select</th> <th>Break Link Timer(ms)</th> <th>Link Fall Inhibit Timer(ms)</th> <th>Auto-Neg Wait Timer(ms)</th> </tr> </thead> <tbody> <tr> <td>&lt;00&gt;</td> <td>80</td> <td>50</td> <td>35</td> </tr> <tr> <td>&lt;01&gt;</td> <td>120</td> <td>75</td> <td>50</td> </tr> <tr> <td>&lt;10&gt;</td> <td>240</td> <td>150</td> <td>100</td> </tr> <tr> <td>&lt;11&gt;</td> <td>NA</td> <td>NA</td> <td>NA</td> </tr> </tbody> </table> <p>Adjusting these bits reduces the time it takes to auto-negotiate between two PHYs. In Fast AN mode, both PHYs should be configured to the same configuration. These 2 bits define the duration for each state of the Auto-Negotiation process according to the table above. The new duration time must be enabled by setting <i>Fast AN En</i> - bit 4 of this register. Note: Using this mode in cases where both link partners are not configured to the same Fast Auto-Negotiation configuration might produce scenarios with unexpected behavior.</p>	Fast AN Select	Break Link Timer(ms)	Link Fall Inhibit Timer(ms)	Auto-Neg Wait Timer(ms)	<00>	80	50	35	<01>	120	75	50	<10>	240	150	100	<11>	NA	NA	NA
Fast AN Select	Break Link Timer(ms)	Link Fall Inhibit Timer(ms)	Auto-Neg Wait Timer(ms)																				
<00>	80	50	35																				
<01>	120	75	50																				
<10>	240	150	100																				
<11>	NA	NA	NA																				

**Table 35. Configuration Register 3 (CFG3), Address 0x001E (continued)**

BIT	BIT NAME	DEFAULT	DESCRIPTION
11	Extended FD Ability	0, RW	Extended Full-Duplex Ability: 1 = Force Full-Duplex while working with link partner in forced 100B-TX. When the PHY is set to Auto-Negotiation or Force 100B-TX and the link partner is operated in Force 100B-TX, the link is always Full Duplex 0 = Disable Extended Full Duplex Ability. Decision to work in Full Duplex or Half Duplex mode follows IEEE specification.
10	RESERVED	0, RO	RESERVED
9	Robust Auto-MDIX	0, RW	Robust Auto-MDIX: 1 = Enable Robust Auto MDI/MDIX resolution 0 = Normal Auto MDI/MDIX mode If link partners are configured to operational modes that are not supported by normal Auto MDI/MDIX mode (like Auto-Neg versus Force 100Base-TX or Force 100Base-TX versus Force 100Base-TX), this Robust Auto MDI/MDIX mode allows MDI/MDIX resolution and prevents deadlock.
8	Fast Auto-MDIX	0, RW	Fast Auto MDI/MDIX: 1 = Enable Fast Auto MDI/MDIX mode 0 = Normal Auto MDI/MDIX mode If both link partners are configured to work in Force 100Base-TX mode (Auto-Negotiation is disabled), this mode enables Automatic MDI/MDIX resolution in a short time.
7	INT_OE	0, RW	Interrupt Output Enable: 1 = INTN/PWDNN Pad is an Interrupt Output. 0 = INTN/PWDNN Pad in a Power-Down Input.
6	FORCE_INTERRUPT	0, RW	Force Interrupt: 1 = Assert interrupt pin. 0 = Normal interrupt mode.
5:3	RESERVED	0, RO	RESERVED: Writes ignored, read as 0.
2	TDR_FAIL	0, RO	TDR Failure: 1 = TDR failed. 0 = Normal TDR operation.
1	TDR_DONE	1, RO	TDR Done: 1 = TDR has completed. 0 = TDR has not completed.
0	TDR_START	0, RW	TDR Start: 1 = Start TDR. 0 = Normal operation

**8.6.26 Control Register (CTRL)**
**Table 36. Control Register (CTRL), Address 0x001F**

BIT	BIT NAME	DEFAULT	DESCRIPTION
15	SW_RESET	0, RW, SC	Software Reset: 1 = Perform a full reset, including registers. 0 = Normal operation.
14	SW_RESTART	0, RW, SC	Software Restart: 1 = Perform a full reset, not including registers. . 0 = Normal operation.
13:0	RESERVED	0, RO	RESERVED: Writes ignored, read as 0.

**8.6.27 Testmode Channel Control (TMCH\_CTRL)**
**Table 37. Testmode Channel Control (TMCH\_CTRL), Address 0x0025**

BIT	BIT NAME	DEFAULT	DESCRIPTION
15:8	RESERVED	0x04	RESERVED
7:5	TM_CH_SEL	0x0	Test mode Channel Select.
			If bit 7 is set then Test mode is driven on all 4 channels. If bit 7 is cleared then test modes are driven according to bits 6:5 as follows:
			00: Channel A
			01: Channel B
			10: Channel C
			11: Channel D
4:0	RESERVED	0x00	RESERVED

### 8.6.28 Fast Link Drop Configuration Register (FLD\_CFG)

**Table 38. Fast Link Drop Configuration Register (FLD\_CFG), Address 0x002D**

BIT	BIT NAME	DEFAULT	DESCRIPTION
15	FLD_EN	0, RW	Fast Link Drop Enable: 1 = Enable FLD. 0 = Normal operation.
14	FLD_1G	0, RW	1000BASE-T Fast Link Drop: 1 = Configure FLD for 1000BASE-T operation. 0 = Normal operation.
13	RESERVED	0, RO	RESERVED
12:8	FLD_STS	0, RO, LH	Fast Link Drop Status: Status Registers that latch high each time a given Fast Link Down mode is activated and causes a link drop (assuming this criterion was enabled): Bit 12: Descrambler Loss Sync Bit 11: RX Errors Bit 10: MLT3 Errors Bit 9: SNR level Bit 8: Signal/Energy Lost
7:5	RESERVED	0, RO	RESERVED
4:0	FLD_SRC_CFG	0, RW	Fast Link Drop Source Configuration: The following FLD sources can be configured independently: Bit 4: Descrambler Loss Sync Bit 3: RX Errors Bit 2: MLT3 Errors Bit 1: SNR level Bit 0: Signal/Energy Lost

### 8.6.29 Configuration Register 4 (CFG4)

**Table 39. Configuration Register 4 (CFG4), Address 0x0031**

BIT	BIT NAME	DEFAULT	DESCRIPTION
15:9	RESERVED	0000 000, RO	RESERVED
8:7	RESERVED	0 0, RW	RESERVED
6:1	RESERVED	001 000, RO	RESERVED
0	PORT_MIRROR_EN	0, RW	Port Mirror Enable: 1 = Enable port mirroring. 0 = Normal operation

### 8.6.30 RGMII Control Register (RGMIICTL)

This register provides access to the RGMII controls.

**Table 40. RGMII Control Register (RGMIICTL), Address 0x0032**

BIT	BIT NAME	DEFAULT	DESCRIPTION
15:8	RESERVED	0, RO	RESERVED: Writes ignored, read as 0.
7	RGMII_EN	1, RW	RGMII Enable: 1 = Enable RGMII interface. 0 = Disable RGMII interface.
6:5	RGMII_RX_HALF_FULL_THR	10, RW	RGMII Receive FIFO Half Full Threshold: This field controls the RGMII receive FIFO half full threshold.
4:3	RGMII_TX_HALF_FULL_THR	10, RW	RGMII Transmit FIFO Half Full Threshold: This field controls the RGMII transmit FIFO half full threshold.
2	RESERVED	0, RO	RESERVED: Writes ignored, read as 0.

**Table 40. RGMII Control Register (RGMIICTL), Address 0x0032 (continued)**

BIT	BIT NAME	DEFAULT	DESCRIPTION
1	RGMII_TX_CLK_DELAY	0, RW	RGMII Transmit Clock Delay: 1 = RGMII transmit clock is shifted relative to transmit data. 0 = RGMII transmit clock is aligned to transmit data.
0	RGMII_RX_CLK_DELAY	0, RW	RGMII Receive Clock Delay: 1 = RGMII receive clock is shifted relative to receive data. 0 = RGMII receive clock is aligned to receive data.

**8.6.31 RGMII Control Register 2 (RGMIICTL2)**
**Table 41. RGMII Control Register 2 (RGMIICTL2), Address 0x0033**

BIT	BIT NAME	DEFAULT	DESCRIPTION
15:5	RESERVED	0, RO	RESERVED
4	RGMII_AF_BYPASS_EN	0, RW	RGMII Async FIFO Bypass Enable: 1 = Enable RGMII Async FIFO Bypass. 0 = Normal operation.
3:0	RESERVED	0, RO	RESERVED

### 8.6.32 100BASE-TX Configuration (100CR)

**Table 42. 100BASE-TX Configuration Register (100CR), Address 0x0043**

BIT	BIT NAME	DEFAULT	DESCRIPTION
15:12	RESERVED	0, RO	RESERVED
11	DESCRAM_TIMEOUT_DIS	0, RW	Disable 100Base-TX Descrambler Timeout: 1 = Disable packet reception when received packet violates the descrambler timeout. This occurs when the packet is longer than 1.5 ms. 0 = Stops packet reception when received packet violates the descrambler timeout. This occurs when the packet is longer than 1.5 ms.
10:7	DESCRAM_TIMEOUT	1111, RW	Descrambler Timeout: Adjust the descrambler time out value. This value refers to the recovery time due to descrambler unlock. Timer is in ms units.
6	FORCE_100_OK	0, RW	Force 100-Mbps Good Link: 1 = Forces 100-Mbps good link. 0 = Normal operation.
5	ENH_MLT3_DET_EN	1, RW	Enhanced MLT-3 Detection Enable: 1 = Enable enhanced MLT-3 Detection. 0 = Normal operation.
4	ENH_IPG_DET_EN	0, RW	Enhanced Interpacket Gap Detection Enable: 1 = Enable enhanced interpacket gap detection. 0 = Normal operation.
3	BYPASS_4B5B_RX	0, RW	Bypass 4B/5B Receive Decoder: 1 = Bypass 4B/5B decoder in receive path. 0 = Normal operation.
2	SCR_DIS	0, RW	Disable Scrambler: 1 = Disable scrambler. 0 = Normal operation.
1	ODD_NIBBLE_DETECT	0, RW	Enable Odd Nibble Detection: 1 = Detect when an odd number of nibbles is received. 0 = Normal operation.
0	FAST_RX_DV	0, RW	Fast RX_DV Enable: 1 = Enable fast RX_DV. 0 = Normal operation.

### 8.6.33 Skew FIFO Status (SKEW\_FIFO)

**Table 43. Skew FIFO Status (SKEW\_FIFO), Address 0x0055**

BIT	BIT NAME	DEFAULT	DESCRIPTION
15:8	RESERVED	0, RO	RESERVED
7:4	CH_B_SKEW	0, RO	Skew of RX channel B to align symbols in # of clock cycles.
3:0	CH_A_SKEW	0, RO	Skew of RX channel A to align symbols in # of clock cycles.

**8.6.34 Strap Configuration Status Register 1 (STRAP\_STS1)**
**Table 44. Strap Configuration Status Register 1 (STRAP\_STS1), Address 0x006E**

BIT	BIT NAME	DEFAULT	DESCRIPTION
15	STRAP_MIRROR_EN	Strap, RO	Mirror Enable Strap: 1 = Port mirroring strapped to enable. 0 = Port mirroring strapped to disable.
14	STRAP_LINK_DOWNSHIFT_EN	Strap, RO	Link Downshift Enable Strap: 1 = Link Downshift strapped to enable. 0 = Link Downshift strapped to disable.
13	STRAP_CLK_OUT_DIS(PAP only)	Strap, RO	Clock Output Disable Strap: 1 = Clock output strapped to disable. 0 = Clock output strapped to enable.
12	STRAP_RGMII_DIS	Strap, RO	RGMII Disable Strap: 1 = RGMII strapped to disable. 0 = RGMII strapped to enable.
11	RESERVED	0, RO	RESERVED
10	STRAP_AMDIX_DIS	Strap, RO	Auto-MDIX Disable Strap: 1 = Auto-MDIX strapped to disable. 0 = Auto-MDIX strapped to enable.
9	STRAP_FORCE_MDI_X	Strap, RO	Force MDI/X Strap: 1 = Force MDIX strapped to enable. 0 = Force MDI strapped to enable.
8	STRAP_HD_EN	Strap, RO	Half Duplex Enable Strap: 1 = Half Duplex strapped to enable. 0 = Full Duplex strapped to enable.
7	STRAP_ANEG_DIS	Strap, RO	Auto-Negotiation Disable Strap: 1 = Auto-Negotiation strapped to disable. 0 = Auto-Negotiation strapped to enable.
6:5	STRAP_ANEG_SEL (PAP)	Strap, RO	Speed Select Strap: SPEED_SEL[1:0] values from straps for PAP devices See Speed Select Strap Details table.
4:0	STRAP_PHY_ADD (PAP)	Strap, RO	PHY Address Strap for PAP: PHY address value from straps.
6	RESERVED (RGZ)	0, RO	RESERVED
5	STRAP_SPEED_SEL (RGZ)	Strap, RO	SPEED_SEL value from strap for RGZ devices See Speed Select Strap Details table.
4	RESERVED	0, RO	RESERVED
3:0	STRAP_PHY_ADD (RGZ)	Strap, RO	PHY Address Strap for RGZ: PHY address value from straps.

### 8.6.35 Strap Configuration Status Register 2 (STRAP\_STS2)

**Table 45. Strap Configuration Status Register 2 (STRAP\_STS2), Address 0x006F**

BIT	BIT NAME	DEFAULT	DESCRIPTION
15:11	RESERVED	0, RO	RESERVED
10	STRAP_FLD	Strap, RO	Fast Link Detect (FLD) Enable Strap: 1 = FLD strapped to enable. 0 = FLD strapped to disable.
9	RESERVED	0, RO	RESERVED
8	RESERVED	0, RO	RESERVED
7	RESERVED	0, RO	RESERVED
6:4	RESERVED (PAP)	0, RO	RESERVED
6:4	STRAP_RGMII_CLK_SKEW_TX (RGZ)	Strap, RO	RGMII Transmit Clock Skew Strap: RGMII_TX_DELAY_CTRL[2:0] values from straps. See RGMII Transmit Clock Skew Details table for more information.
3	RESERVED	0, RO	RESERVED
2:0	RESERVED (PAP)	0, RO	RESERVED
2:0	STRAP_RGMII_CLK_SKEW_RX (RGZ)	Strap, RO	RGMII Receive Clock Skew Strap: RGMII_RX_DELAY_CTRL[2:0] values from straps. See RGMII Transmit Clock Skew Details table for more information.

### 8.6.36 BIST Control and Status Register 1 (BICSR1)

**Table 46. BIST Control and Status Register 1 (BICSR1), Address 0x0071**

BIT	BIT NAME	DEFAULT	DESCRIPTION
15:0	PRBS_BYTE_CNT	0x0000, RO	Holds the number of total bytes received by the PRBS checker. Value in this register is locked when write is done to register BICSR2 bit[0] or bit[1]. The count stops at 0xFFFF when PRBS_COUNT_MODE in BICSR register (0x0016) is set to 0.

### 8.6.37 BIST Control and Status Register 2 (BICSR2)

**Table 47. BIST Control and Status Register 2 (BICSR2), Address 0x0072**

BIT	BIT NAME	DEFAULT	DESCRIPTION
15:11	Reserved	0x00, RO	Ignored on Read
10	PRBS_PKT_CNT_OVF	0, RO	PRBS Checker Packet Count Overflow If set, PRBS Packet counter has reached overflow. Overflow is cleared when PRBS counters are cleared by setting bit #1 of this register.
9	PRBS_BYTE_CNT_OVF	0, RO	PRBS Byte Count Overflow If set, PRBS Byte counter has reached overflow. Overflow is cleared when PRBS counters are cleared by setting bit #1 of this register.
8	Reserved	0,RO	Ignore on Read
7:0	PRBS_ERR_CNT	0x00, RO	Holds number of error bytes that are received by PRBS checker. Value in this register is locked when write is done to bit[0] or bit[1] When PRBS Count Mode set to zero, count stops on 0xFF (see register 0x0016) Notes: Writing bit 0 generates a lock signal for the PRBS counters. Writing bit 1 generates a lock and clear signal for the PRBS counters

### 8.6.38 RGMII Delay Control Register (RGMIIIDCTL)

This register provides access to the RGMII delay controls.

**Table 48. RGMII Delay Control Register (RGMIIIDCTL), Address 0x0086**

BIT	BIT NAME	DEFAULT	DESCRIPTION
15:8	RESERVED	0, RO	RESERVED: Writes ignored, read as 0.
7:4	RGMII_TX_DELAY_CTRL	RW, 0111	RGMII Transmit Clock Delay: 1111: 4.00 ns 1110: 3.75 ns 1101: 3.50 ns 1100: 3.25 ns 1011: 3.00 ns 1010: 2.75 ns 1001: 2.50 ns 1000: 2.25 ns 0111: 2.00 ns 0110: 1.75 ns 0101: 1.50 ns 0100: 1.25 ns 0011: 1.00 ns 0010: 0.75 ns 0001: 0.50 ns 0000: 0.25 ns
3:0	RGMII_RX_DELAY_CTRL	RW, 0111	RGMII Receive Clock Delay: 1111: 4.00 ns 1110: 3.75 ns 1101: 3.50 ns 1100: 3.25 ns 1011: 3.00 ns 1010: 2.75 ns 1001: 2.50 ns 1000: 2.25 ns 0111: 2.00 ns 0110: 1.75 ns 0101: 1.50 ns 0100: 1.25 ns 0011: 1.00 ns 0010: 0.75 ns 0001: 0.50 ns 0000: 0.25 ns

### 8.6.39 Sync FIFO Control (SYNC\_FIFO\_CTRL)

**Table 49. Sync FIFO Control (SYNC\_FIFO\_CTRL), Address 0x00E9**

BIT	BIT NAME	DEFAULT	DESCRIPTION
15:0	RESERVED	0x9F22, RW	RESERVED

### 8.6.40 Loopback Configuration Register (LOOPCR)

**Table 50. Loopback Configuration Register (LOOPCR), Address 0x00FE**

BIT	BIT NAME	DEFAULT	DESCRIPTION
15:0	LOOP_CFG_VAL	1110 0111 0010 0001, RW	Loopback Configuration Value: 1110 0111 0010 000: Configuration for loopback modes. A software reset through bit 14 of the Control Register (CTRL), address 0x001F, is required after changes to this register value. Other values for this register are not recommended.

### 8.6.41 Receive Configuration Register (RXFCFG)

This register provides receive configuration for Wake-on-LAN (WoL).

**Table 51. Receive Configuration Register (RXFCFG), Address 0x0134**

BIT	BIT NAME	DEFAULT	DESCRIPTION
15:12	RESERVED	0, RO	RESERVED
11	WOL_OUT_CLEAR	0, RW, SC	Clear Wake-on-LAN Output: This bit is only applicable when configured for level mode. 1 = Clear Wake-on-LAN output
10:9	WOL_OUT_STRETCH	00, RW	Wake-on-LAN Output Stretch: If WoL out is configured for pulse mode, the pulse length is defined as the following number of 125-MHz clock cycles: 11 = 64 clock cycles 10 = 32 clock cycles 01 = 16 clock cycles 00 = 8 clock cycles
8	WOL_OUT_MODE	0, RW	Wake-on-LAN Output Mode: 1 = Level Mode. WoL is cleared by a write to WOL_OUT_CLEAR (bit 11). 0 = Pulse Mode. Pulse width is configured via WOL_OUT_STRETCH (bits 10:9).
7	ENHANCED_MAC_SUPPORT	0, RW	Enable Enhanced Receive Features: 1 = Enable for Wake-on-LAN, CRC check, and Receive 1588 indication. 0 = Normal operation.
6	RESERVED	0, RO	RESERVED
5	SCRON_EN	0, RW	Enable SecureOn Password: 1 = SecureOn Password enabled. 0 = SecureOn Password disabled.
4	WAKE_ON_UCAST	0, RW	Wake on Unicast Packet: 1 = Issue an interrupt upon reception of Unicast packet. 0 = Do not issue an interrupt upon reception of Unicast packet.
3	RESERVED	0, RO	RESERVED
2	WAKE_ON_BCAST	1, RW	Wake on Broadcast Packet: 1 = Issue an interrupt upon reception of Broadcast packet. 0 = Do not issue an interrupt upon reception of Broadcast packet.
1	WAKE_ON_PATTERN	0, RW	Wake on Pattern Match: 1 = Issue an interrupt upon pattern match. 0 = Do not issue an interrupt upon pattern match.
0	WAKE_ON_MAGIC	0, RW	Wake on Magic Packet: 1 = Issue an interrupt upon reception of Magic packet. 0 = Do not issue an interrupt upon reception of Magic packet.

### 8.6.42 Receive Status Register (RXFSTS)

This register provides status for receive functionality.

**Table 52. Receive Status Register (RXFSTS), Address 0x0135**

BIT	BIT NAME	DEFAULT	DESCRIPTION
15:8	RESERVED	0, RO	RESERVED
7	SFD_ERR	0, RO, LH, SC	SFD Error: 1 = Packet with SFD error (without an 0x5D SFD byte) received. 0 = No SFD error seen.
6	BAD_CRC	0, RO, LH, SC	Bad CRC: 1 = A packet with a bad CRC was received. 0 = No bad CRC seen.
5	SCRON_HACK	0, RO, LH, SC	SecureOn Hack Attempt Flag: 1 = SecureOn Hack attempt seen. 0 = No SecureOn Hack attempt seen.
4	UCAST_RCVD	0, RO, LH, SC	Unicast Packet Received: 1 = A valid Unicast packet was received. 0 = No valid Unicast packet was received.
3	RESERVED	0, RO	RESERVED
2	BCAST_RCVD	0, RO, LH, SC	Broadcast Packet Received: 1 = A valid Broadcast packet was received. 0 = No valid Broadcast packet was received.
1	PATTERN_RCVD	0, RO, LH, SC	Pattern Match Received: 1 = A valid packet with the configured pattern was received. 0 = No valid packet with the configured pattern was received.
0	MAGIC_RCVD	0, RO, LH, SC	Magic Packet Received: 1 = A valid Magic packet was received. 0 = No valid Magic packet was received.

### 8.6.43 Pattern Match Data Register 1 (RXFPMD1)

**Table 53. Pattern Match Data Register 1 (RXFPMD1), Address 0x0136**

BIT	BIT NAME	DEFAULT	DESCRIPTION
15:0	PMATCH_DATA_15_0	0, RW	Bits 15:0 of Perfect Match Data - used for DA (destination address) match

### 8.6.44 Pattern Match Data Register 2 (RXFPMD2)

**Table 54. Pattern Match Data Register 2 (RXFPMD2), address 0x0137**

BIT	BIT NAME	DEFAULT	DESCRIPTION
15:0	PMATCH_DATA_31_16	0, RW	Bits 31:16 of Perfect Match Data - used for DA (destination address) match

### 8.6.45 Pattern Match Data Register 3 (RXFPMD3)

**Table 55. Pattern Match Data Register 3 (RXFPMD3), address 0x0138**

BIT	BIT NAME	DEFAULT	DESCRIPTION
15:0	PMATCH_DATA_47_32	0, RW	Bits 47:32 of Perfect Match Data - used for DA (destination address) match

### 8.6.46 SecureOn Pass Register 2 (RXFSOP1)

**Table 56. SecureOn Pass Register 1 (RXFSOP1), Address 0x0139**

BIT	BIT NAME	DEFAULT	DESCRIPTION
15:0	SCRON_PASSWORD_15_0	0, RW	Bits 15:0 of secure-on password for magic packet

### 8.6.47 SecureOn Pass Register 2 (RXFSOP2)

**Table 57. SecureOn Pass Register 2 (RXFSOP2), Address 0x013A**

BIT	BIT NAME	DEFAULT	DESCRIPTION
15:0	SCRON_PASSWORD_31_16	0, RW	Bits 31:16 of secure-on password for magic packet

### 8.6.48 SecureOn Pass Register 3 (RXFSOP3)

**Table 58. SecureOn Pass Register 3 (RXFSOP3), Address 0x013B**

BIT	BIT NAME	DEFAULT	DESCRIPTION
15:0	SCRON_PASSWORD_47_32	0, RW	Bits 47:32 of secure-on password for magic packet

### 8.6.49 Receive Pattern Register 1 (RXFPAT1)

**Table 59. Receive Pattern Register 1 (RXFPAT1), Address 0x013C**

BIT	BIT NAME	DEFAULT	DESCRIPTION
15:0	PATTERN_BYTES_0_1	0, RW	Bytes 0 (LSbyte) + 1 of the configured pattern. Each byte can be masked separately through the RXF_PATTERN_BYTE_MASK registers.

### 8.6.50 Receive Pattern Register 2 (RXFPAT2)

**Table 60. Receive Pattern Register 2 (RXFPAT2), Address 0x013D**

BIT	BIT NAME	DEFAULT	DESCRIPTION
15:0	PATTERN_BYTES_2_3	0, RW	Bytes 2 + 3 of the configured pattern. Each byte can be masked separately through the RXF_PATTERN_BYTE_MASK registers.

**8.6.51 Receive Pattern Register 3 (RXFPAT3)**
**Table 61. Receive Pattern Register 3 (RXFPAT3), Address 0x013E**

BIT	BIT NAME	DEFAULT	DESCRIPTION
15:0	PATTERN_BYTES_4_5	0, RW	Bytes 4 + 5 of the configured pattern. Each byte can be masked separately through the RXF_PATTERN_BYTE_MASK registers.

**8.6.52 Receive Pattern Register 4 (RXFPAT4)**
**Table 62. Receive Pattern Register 4 (RXFPAT4), Address 0x013F**

BIT	BIT NAME	DEFAULT	DESCRIPTION
15:0	PATTERN_BYTES_6_7	0, RW	Bytes 6 + 7 of the configured pattern. Each byte can be masked separately through the RXF_PATTERN_BYTE_MASK registers.

**8.6.53 Receive Pattern Register 5 (RXFPAT5)**
**Table 63. Receive Pattern Register 5 (RXFPAT5), Address 0x0140**

BIT	BIT NAME	DEFAULT	DESCRIPTION
15:0	PATTERN_BYTES_8_9	0, RW	Bytes 8 + 9 of the configured pattern. Each byte can be masked separately through the RXF_PATTERN_BYTE_MASK registers.

**8.6.54 Receive Pattern Register 6 (RXFPAT6)**
**Table 64. Receive Pattern Register 6 (RXFPAT6), Address 0x0141**

BIT	BIT NAME	DEFAULT	DESCRIPTION
15:0	PATTERN_BYTES_10_11	0, RW	Bytes 10 + 11 of the configured pattern. Each byte can be masked separately through the RXF_PATTERN_BYTE_MASK registers.

**8.6.55 Receive Pattern Register 7 (RXFPAT7)**
**Table 65. Receive Pattern Register 7 (RXFPAT7), Address 0x0142**

BIT	BIT NAME	DEFAULT	DESCRIPTION
15:0	PATTERN_BYTES_12_13	0, RW	Bytes 12 + 13 of the configured pattern. Each byte can be masked separately through the RXF_PATTERN_BYTE_MASK registers.

**8.6.56 Receive Pattern Register 8 (RXFPAT8)**
**Table 66. Receive Pattern Register 8 (RXFPAT8), Address 0x0143**

BIT	BIT NAME	DEFAULT	DESCRIPTION
15:0	PATTERN_BYTES_14_15	0, RW	Bytes 0 14 + 15 of the configured pattern. Each byte can be masked separately through the RXF_PATTERN_BYTE_MASK registers.

**8.6.57 Receive Pattern Register 9 (RXFPAT9)**
**Table 67. Receive Pattern Register 9 (RXFPAT9), Address 0x0144**

BIT	BIT NAME	DEFAULT	DESCRIPTION
15:0	PATTERN_BYTES_16_17	0, RW.	Bytes 16 + 17 of the configured pattern. Each byte can be masked separately through the RXF_PATTERN_BYTE_MASK registers.

### 8.6.58 Receive Pattern Register 10 (RXFPAT10)

**Table 68. Receive Pattern Register 10 (RXFPAT10), Address 0x0145**

BIT	BIT NAME	DEFAULT	DESCRIPTION
15:0	PATTERN_BYTES_18_19	0, RW	Bytes 18 + 19 of the configured pattern. Each byte can be masked separately through the RXF_PATTERN_BYTE_MASK registers.

### 8.6.59 Receive Pattern Register 11 (RXFPAT11)

**Table 69. Receive Pattern Register 11 (RXFPAT11), Address 0x0146**

BIT	BIT NAME	DEFAULT	DESCRIPTION
15:0	PATTERN_BYTES_20_21	0, RW	Bytes 20 + 21 of the configured pattern. Each byte can be masked separately through the RXF_PATTERN_BYTE_MASK registers.

### 8.6.60 Receive Pattern Register 12 (RXFPAT12)

**Table 70. Receive Pattern Register 12 (RXFPAT12), Address 0x0147**

BIT	BIT NAME	DEFAULT	DESCRIPTION
15:0	PATTERN_BYTES_22_23	0, RW	Bytes 22 + 23 of the configured pattern. Each byte can be masked separately through the RXF_PATTERN_BYTE_MASK registers.

### 8.6.61 Receive Pattern Register 13 (RXFPAT13)

**Table 71. Receive Pattern Register 13 (RXFPAT13), Address 0x0148**

BIT	BIT NAME	DEFAULT	DESCRIPTION
15:0	PATTERN_BYTES_24_25	0, RW	Bytes 24 + 25 of the configured pattern. Each byte can be masked separately through the RXF_PATTERN_BYTE_MASK registers.

### 8.6.62 Receive Pattern Register 14 (RXFPAT14)

**Table 72. Receive Pattern Register 14 (RXFPAT14), Address 0x0149**

BIT	BIT NAME	DEFAULT	DESCRIPTION
15:0	PATTERN_BYTES_26_27	0, RW	Bytes 26 + 27 of the configured pattern. Each byte can be masked separately through the RXF_PATTERN_BYTE_MASK registers.

### 8.6.63 Receive Pattern Register 15 (RXFPAT15)

**Table 73. Receive Pattern Register 15 (RXFPAT15), address 0x014A**

BIT	BIT NAME	DEFAULT	DESCRIPTION
15:0	PATTERN_BYTES_28_29	0, RW	Bytes 28 + 29 of the configured pattern. Each byte can be masked separately through the RXF_PATTERN_BYTE_MASK registers.

### 8.6.64 Receive Pattern Register 16 (RXFPAT16)

**Table 74. Receive Pattern Register 16 (RXFPAT16), Address 0x014B**

BIT	BIT NAME	DEFAULT	DESCRIPTION
15:0	PATTERN_BYTES_30_31	0, RW	Bytes 30 + 31 of the configured pattern. Each byte can be masked separately through the RXF_PATTERN_BYTE_MASK registers.

**8.6.65 Receive Pattern Register 17 (RXFPAT17)**
**Table 75. Receive Pattern Register 17 (RXFPAT17), Address 0x014C**

BIT	BIT NAME	DEFAULT	DESCRIPTION
15:0	PATTERN_BYTES_32_33	0, RW	Bytes 32 + 33 of the configured pattern. Each byte can be masked separately through the RXF_PATTERN_BYTE_MASK registers.

**8.6.66 Receive Pattern Register 18 (RXFPAT18)**
**Table 76. Receive Pattern Register 18 (RXFPAT18), Address 0x014D**

BIT	BIT NAME	DEFAULT	DESCRIPTION
15:0	PATTERN_BYTES_34_35	0, RW	Bytes 34 + 35 of the configured pattern. Each byte can be masked separately through the RXF_PATTERN_BYTE_MASK registers.

**8.6.67 Receive Pattern Register 19 (RXFPAT19)**
**Table 77. Receive Pattern Register 19 (RXFPAT19), Address 0x014E**

BIT	BIT NAME	DEFAULT	DESCRIPTION
15:0	PATTERN_BYTES_36_37	0, RW	Bytes 36 + 37 of the configured pattern. Each byte can be masked separately through the RXF_PATTERN_BYTE_MASK registers.

**8.6.68 Receive Pattern Register 20 (RXFPAT20)**
**Table 78. Receive Pattern Register 20 (RXFPAT20), Address 0x014F**

BIT	BIT NAME	DEFAULT	DESCRIPTION
15:0	PATTERN_BYTES_38_39	0, RW	Bytes 38 + 39 of the configured pattern. Each byte can be masked separately through the RXF_PATTERN_BYTE_MASK registers.

**8.6.69 Receive Pattern Register 21 (RXFPAT21)**
**Table 79. Receive Pattern Register 21 (RXFPAT21), Address 0x0150**

BIT	BIT NAME	DEFAULT	DESCRIPTION
15:0	PATTERN_BYTES_38_39	0, RW	Bytes 38 + 39 of the configured pattern. Each byte can be masked separately through the RXF_PATTERN_BYTE_MASK registers.

**8.6.70 Receive Pattern Register 22 (RXFPAT22)**
**Table 80. Receive Pattern Register 22 (RXFPAT22), Address 0x0151**

BIT	BIT NAME	DEFAULT	DESCRIPTION
15:0	PATTERN_BYTES_42_43	0, RW	Bytes 42 + 43 of the configured pattern. Each byte can be masked separately through the RXF_PATTERN_BYTE_MASK registers.

**8.6.71 Receive Pattern Register 23 (RXFPAT23)**
**Table 81. Receive Pattern Register 23 (RXFPAT23), Address 0x0152**

BIT	BIT NAME	DEFAULT	DESCRIPTION
15:0	PATTERN_BYTES_44_45	0, RW	Bytes 44 + 45 of the configured pattern. Each byte can be masked separately through the RXF_PATTERN_BYTE_MASK registers.

### 8.6.72 Receive Pattern Register 24 (RXFPAT24)

**Table 82. Receive Pattern Register 24 (RXFPAT24), Address 0x0153**

BIT	BIT NAME	DEFAULT	DESCRIPTION
15:0	PATTERN_BYTES_46_47	0, RW	Bytes 46 + 47 of the configured pattern. Each byte can be masked separately through the RXF_PATTERN_BYTE_MASK registers.

### 8.6.73 Receive Pattern Register 25 (RXFPAT25)

**Table 83. Receive Pattern Register 25 (RXFPAT25), Address 0x0154**

BIT	BIT NAME	DEFAULT	DESCRIPTION
15:0	PATTERN_BYTES_48_49	0, RW	Bytes 48 + 49 of the configured pattern. Each byte can be masked separately through the RXF_PATTERN_BYTE_MASK registers.

### 8.6.74 Receive Pattern Register 26 (RXFPAT26)

**Table 84. Receive Pattern Register 26 (RXFPAT26), Address 0x0155**

BIT	BIT NAME	DEFAULT	DESCRIPTION
15:0	PATTERN_BYTES_50_51	0, RW	Bytes 50 + 51 of the configured pattern. Each byte can be masked separately through the RXF_PATTERN_BYTE_MASK registers.

### 8.6.75 Receive Pattern Register 27 (RXFPAT27)

**Table 85. Receive Pattern Register 27 (RXFPAT27), Address 0x0156**

BIT	BIT NAME	DEFAULT	DESCRIPTION
15:0	PATTERN_BYTES_52_53	0, RW	Bytes 52 + 53 of the configured pattern. Each byte can be masked separately through the RXF_PATTERN_BYTE_MASK registers.

### 8.6.76 Receive Pattern Register 28 (RXFPAT28)

**Table 86. Receive Pattern Register 28 (RXFPAT28), Address 0x0157**

BIT	BIT NAME	DEFAULT	DESCRIPTION
15:0	PATTERN_BYTES_54_55	0, RW	Bytes 54 + 55 of the configured pattern. Each byte can be masked separately through the RXF_PATTERN_BYTE_MASK registers.

### 8.6.77 Receive Pattern Register 29 (RXFPAT29)

**Table 87. Receive Pattern Register 29 (RXFPAT29), Address 0x0158**

BIT	BIT NAME	DEFAULT	DESCRIPTION
15:0	PATTERN_BYTES_56_57	0, RW	Bytes 56 + 57 of the configured pattern. Each byte can be masked separately through the RXF_PATTERN_BYTE_MASK registers.

### 8.6.78 Receive Pattern Register 30 (RXFPAT30)

**Table 88. Receive Pattern Register 30 (RXFPAT30), Address 0x0159**

BIT	BIT NAME	DEFAULT	DESCRIPTION
15:0	PATTERN_BYTES_58_59	0, RW	Bytes 58 + 59 of the configured pattern. Each byte can be masked separately through the RXF_PATTERN_BYTE_MASK registers.

**8.6.79 Receive Pattern Register 31 (RXFPAT31)**
**Table 89. Receive Pattern Register 31 (RXFPAT31), Address 0x015A**

BIT	BIT NAME	DEFAULT	DESCRIPTION
15:0	PATTERN_BYTES_0_1	0, RW	Bytes 60 + 61 of the configured pattern. Each byte can be masked separately through the RXF_PATTERN_BYTE_MASK registers.

**8.6.80 Receive Pattern Register 32 (RXFPAT32)**
**Table 90. Receive Pattern Register 32 (RXFPAT32), Address 0x015B**

BIT	BIT NAME	DEFAULT	DESCRIPTION
15:0	PATTERN_BYTES_62_63	0, RW	Bytes 62 + 63 of the configured pattern. Each byte can be masked separately through the RXF_PATTERN_BYTE_MASK registers.

**8.6.81 Receive Pattern Byte Mask Register 1 (RXFPBM1)**
**Table 91. Receive Pattern Byte Mask Register 1 (RXFPBM1), Address 0x015C**

BIT	BIT NAME	DEFAULT	DESCRIPTION
15:0	PATTERN_BYTES_MASK_0_15	0, RW	Masks for bytes 0 to 15 of the pattern. A 1 indicates a mask for the associated byte.

**8.6.82 Receive Pattern Byte Mask Register 2 (RXFPBM2)**
**Table 92. Receive Pattern Byte Mask Register 2 (RXFPBM2), Address 0x015D**

BIT	BIT NAME	DEFAULT	DESCRIPTION
15:0	PATTERN_BYTES_MASK_16_31	0, RW	Masks for bytes 16 to 31 of the pattern. A 1 indicates a mask for the associated byte.

**8.6.83 Receive Pattern Byte Mask Register 3 (RXFPBM3)**
**Table 93. Receive Pattern Byte Mask Register 3 (RXFPBM3), Address 0x015E**

BIT	BIT NAME	DEFAULT	DESCRIPTION
15:0	PATTERN_BYTES_MASK_32_47	0, RW	Masks for bytes 32 to 47 of the pattern. A 1 indicates a mask for the associated byte.

**8.6.84 Receive Pattern Byte Mask Register 4 (RXFPBM4)**
**Table 94. Receive Pattern Byte Mask Register 4 (RXFPBM4), Address 0x015F**

BIT	BIT NAME	DEFAULT	DESCRIPTION
15:0	PATTERN_BYTES_MASK_48_63	0, RW	Masks for bytes 48 to 63 of the pattern. A 1 indicates a mask for the associated byte.

**8.6.85 Receive Pattern Control (RXFPATC)**
**Table 95. Receive Status Register (RXFSTS), Address 0x0161**

BIT	BIT NAME	DEFAULT	DESCRIPTION
15:6	RESERVED	0, RO	RESERVED: Writes ignored, read as 0.
5:0	PATTERN_START_POINT	0, RW	Number of bytes after SFD where comparison of the RX packet to the configured pattern begins: 111111 - Start compare in the 64th byte after SFD 000000 - Start compare in the 1st byte after SFD

**8.6.86 I/O Configuration (IO\_MUX\_CFG)**
**Table 96. I/O Configuration (IO\_MUX\_CFG), Address 0x0170**

BIT	BIT NAME	DEFAULT	DESCRIPTION
15:13	RESERVED	0, RO	RESERVED
12:8	CLK_O_SEL	0 1100, RW	Clock Output Select: 01101 - 11111: RESERVED 01100: Reference clock (synchronous to XI input clock) 01011: Channel D transmit clock 01010: Channel C transmit clock 01001: Channel B transmit clock 01000: Channel A transmit clock 00111: Channel D receive clock divided by 5 00110: Channel C receive clock divided by 5 00101: Channel B receive clock divided by 5 00100: Channel A receive clock divided by 5 00011: Channel D receive clock 00010: Channel C receive clock 00001: Channel B receive clock 00000: Channel A receive clock
7	RESERVED	0, RO	RESERVED
6	CLK_O_DISABLE	PAP: Strap, RW RGZ: 0,RW	Clock Output Disable: 1 = Disable clock output on CLK_OUT pin. 0 = Enable clock output on CLK_OUT pin.
5	RESERVED	0, RO	RESERVED
4:0	IO_IMPEDANCE_CTRL	TRIM, RW	Impedance Control for MAC I/Os: Output impedance approximate range from 35-70 $\Omega$ in 32 steps. Lowest being 11111 and highest being 00000. Range and Step size will vary with process. Default is set to 50 $\Omega$ by trim. But the default register value can vary by process. Non default values of MAC I/O impedance can be used based on trace impedance. Mismatch between device and trace impedance can cause voltage overshoot and undershoot.

**8.6.87 GPIO Mux Control Register 1 (GPIO\_MUX\_CTRL1)**

This register is only available for PAP devices. It is not applicable to RGZ devices.

**Table 97. GPIO Mux Control Register 1 (GPIO\_MUX\_CTRL1), Address 0x0171**

BIT	BIT NAME	DEFAULT	DESCRIPTION
15:12	RX_D7_GPIO_CTRL	RW, 0000	RX_D7 GPIO Control: 1010 - 1111: RESERVED 1001: Constant '1' 1000: Constant '0' 0111: PRBS Errors / Loss of Sync 0110: LED_3 0101: RESERVED 0100: Energy Detect (1000Base-T and 100Base-TX only) 0011: WOL 0010: 1588 RX SFD 0001: 1588 TX SFD 0000: RX_D7
11:8	RX_D6_GPIO_CTRL	RW, 0000	RX_D6 GPIO Control: 1010 - 1111: RESERVED 1001: Constant '1' 1000: Constant '0' 0111: PRBS Errors / Loss of Sync 0110: LED_3 0101: RESERVED 0100: Energy Detect (1000Base-T and 100Base-TX only) 0011: WOL 0010: 1588 RX SFD 0001: 1588 TX SFD 0000: RX_D6
7:4	RX_D5_GPIO_CTRL	RW, 0000	RX_D5 GPIO Control: 1010 - 1111: RESERVED 1001: Constant '1' 1000: Constant '0' 0111: PRBS Errors / Loss of Sync 0110: LED_3 0101: RESERVED 0100: Energy Detect (1000Base-T and 100Base-TX only) 0011: WOL 0010: 1588 RX SFD 0001: 1588 TX SFD 0000: RX_D5

**Table 97. GPIO Mux Control Register 1 (GPIO\_MUX\_CTRL1), Address 0x0171 (continued)**

BIT	BIT NAME	DEFAULT	DESCRIPTION
3:0	RX_D4_GPIO_CTRL	RW, 0000	RX_D4 GPIO Control: 1010 - 1111: RESERVED 1001: Constant '1' 1000: Constant '0' 0111: PRBS Errors / Loss of Sync 0110: LED_3 0101: RESERVED 0100: Energy Detect (1000Base-T and 100Base-TX only) 0011: WOL 0010: 1588 RX SFD 0001: 1588 TX SFD 0000: RX_D4

**8.6.88 GPIO Mux Control Register 2 (GPIO\_MUX\_CTRL2)**

This description is only for PAP devices. For RGZ devices, refer to [GPIO Mux Control Register \(GPIO\\_MUX\\_CTRL\)](#)

**Table 98. GPIO Mux Control Register 2 (GPIO\_MUX\_CTRL2), Address 0x0172**

BIT	BIT NAME	DEFAULT	DESCRIPTION
15:12	RESERVED	0, RO	RESERVED
11:8	CRS_GPIO_CTRL	RW, 0000	CRS GPIO Control: 1010 - 1111: RESERVED 1001: Constant '1' 1000: Constant '0' 0111: PRBS Errors / Loss of Sync 0110: LED_3 0101: RESERVED 0100: Energy Detect (1000Base-T and 100Base-TX only) 0011: WOL 0010: 1588 RX SFD 0001: 1588 TX SFD 0000: CRS
7:4	COL_GPIO_CTRL	RW, 0000	COL GPIO Control: 1010 - 1111: RESERVED 1001: Constant '1' 1000: Constant '0' 0111: PRBS Errors / Loss of Sync 0110: LED_3 0101: RESERVED 0100: Energy Detect (1000Base-T and 100Base-TX only) 0011: WOL 0010: 1588 RX SFD 0001: 1588 TX SFD 0000: COL
3:0	RX_ER_GPIO_CTRL	RW, 0000	RX_ER GPIO Control: 1010 - 1111: RESERVED 1001: Constant '1' 1000: Constant '0' 0111: PRBS Errors / Loss of Sync 0110: LED_3 0101: RESERVED 0100: Energy Detect (1000Base-T and 100Base-TX only) 0011: WOL 0010: 1588 RX SFD 0001: 1588 TX SFD 0000: RX_ER

### 8.6.89 GPIO Mux Control Register (GPIO\_MUX\_CTRL)

This description is only for RGZ devices. For PAP devices refer to [GPIO Mux Control Register 2 \(GPIO\\_MUX\\_CTRL2\)](#)

**Table 99. GPIO Mux Control Register (GPIO\_MUX\_CTRL), Address 0x0172**

BIT	BIT NAME	DEFAULT	DESCRIPTION
15:8	RESERVED	0, RO	RESERVED
7:4	GPIO_1_CTRL	RW, 0000	GPIO_1 Control: 1010 - 1111: RESERVED 1001: Constant 1 1000: Constant 0 0111: PRBS Errors / Loss of Sync 0110: LED_3 0101: RESERVED 0100: Energy Detect (1000Base-T and 100Base-TX only) 0011: WOL 0010: 1588 RX SFD 0001: 1588 TX SFD 0000: COL
3:0	GPIO_0_CTRL	RW, 0000	GPIO_0 Control: 1010 - 1111: RESERVED 1001: Constant 1 1000: Constant 0 0111: PRBS Errors / Loss of Sync 0110: LED_3 0101: RESERVED 0100: Energy Detect (1000Base-T and 100Base-TX only) 0011: WOL 0010: 1588 RX SFD 0001: 1588 TX SFD 0000: RX_ER

**8.6.90 TDR General Configuration Register 1 (TDR\_GEN\_CFG1)**
**Table 100. TDR General Configuration Register 1 (TDR\_GEN\_CFG1), Address 0x0180**

BIT	BIT NAME	DEFAULT	DESCRIPTION
15:13	RESERVED	0, RO	RESERVED
12	TDR_CH_CD_BYPASS	0, RW	TDR Bypass for Channel C and D: 1 = Bypass channel C and D in TDR tests. 0 = Normal operation.
11	TDR_CROSS_MODE_DIS	0, RW	Disable TDR Cross Mode: 1 = Disable cross mode option. Do not check cross channels. Only listen to the channel being used for transmit. 0 = Normal operation.
10	TDR_NLP_CHECK	1, RW	TDR NLP Check: 1 = Check for NLPs during silence. 0 = Normal operation.
9:7	TDR_AVG_NUM	110, RW	Number Of TDR Cycles to Average: 111: RESERVED: Writes ignored, read as 0. 110: 64 TDR cycles 101: 32 TDR cycles 100: 16 TDR cycles 011: 8 TDR cycles 010: 4 TDR cycles 001: 2 TDR cycles 000: 1 TDR cycle
6:4	TDR_SEG_NUM	101, RW	Set the number of TDR segments to check.
3:0	TDR_CYCLE_TIME	010, RW	Set the time for each TDR cycle. Value is measured in microseconds.

**8.6.91 TDR Peak Locations Register 1 (TDR\_PEAKE\_LOC\_1)**
**Table 101. TDR Peak Locations Register 1 (TDR\_PEAKE\_LOC\_1), Address 0x0190**

BIT	BIT NAME	DEFAULT	DESCRIPTION
15:8	TDR_PEAKE_LOC_A_1	0, RO	Location of the second peak discovered by the TDR mechanism on channel A. The value of these bits is translated into distance from the PHY.
7:0	TDR_PEAKE_LOC_A_0	0, RO	Location of the first peak discovered by the TDR mechanism on channel A. The value of these bits is translated into distance from the PHY.

**8.6.92 TDR Peak Locations Register 2 (TDR\_PEAKE\_LOC\_2)**
**Table 102. TDR Peak Locations Register 2 (TDR\_PEAKE\_LOC\_2), Address 0x0191**

BIT	BIT NAME	DEFAULT	DESCRIPTION
15:8	TDR_PEAKE_LOC_A_3	0, RO	Location of the fourth peak discovered by the TDR mechanism on channel A. The value of these bits is translated into distance from the PHY.
7:0	TDR_PEAKE_LOC_A_2	0, RO	Location of the third peak discovered by the TDR mechanism on channel A. The value of these bits is translated into distance from the PHY.

**8.6.93 TDR Peak Locations Register 3 (TDR\_PEAKE\_LOC\_3)**
**Table 103. TDR Peak Locations Register 3 (TDR\_PEAKE\_LOC\_3), Address 0x0192**

BIT	BIT NAME	DEFAULT	DESCRIPTION
15:8	TDR_PEAKE_LOC_B_0	0, RO	Location of the first peak discovered by the TDR mechanism on channel B. The value of these bits is translated into distance from the PHY.
7:0	TDR_PEAKE_LOC_A_4	0, RO	Location of the fifth peak discovered by the TDR mechanism on channel A. The value of these bits is translated into distance from the PHY.

**8.6.94 TDR Peak Locations Register 4 (TDR\_PEAKE\_LOC\_4)**
**Table 104. TDR Peak Locations Register 4 (TDR\_PEAKE\_LOC\_4), Address 0x0193**

BIT	BIT NAME	DEFAULT	DESCRIPTION
15:8	TDR_PEAKE_LOC_B_2	0, RO	Location of the third peak discovered by the TDR mechanism on channel B. The value of these bits is translated into distance from the PHY.
7:0	TDR_PEAKE_LOC_B_1	0, RO	Location of the second peak discovered by the TDR mechanism on channel B. The value of these bits is translated into distance from the PHY.

**8.6.95 TDR Peak Locations Register 5 (TDR\_PEAKE\_LOC\_5)**
**Table 105. TDR Peak Locations Register 5 (TDR\_PEAKE\_LOC\_5), Address 0x0194**

BIT	BIT NAME	DEFAULT	DESCRIPTION
15:8	TDR_PEAKE_LOC_B_4	0, RO	Location of the fifth peak discovered by the TDR mechanism on channel B. The value of these bits is translated into distance from the PHY.
7:0	TDR_PEAKE_LOC_B_3	0, RO	Location of the fourth peak discovered by the TDR mechanism on channel B. The value of these bits is translated into distance from the PHY.

**8.6.96 TDR Peak Locations Register 6 (TDR\_PEAKE\_LOC\_6)**
**Table 106. TDR Peak Locations Register 6 (TDR\_PEAKE\_LOC\_6), Address 0x0195**

BIT	BIT NAME	DEFAULT	DESCRIPTION
15:8	TDR_PEAKE_LOC_C_1	0, RO	Location of the second peak discovered by the TDR mechanism on channel C. The value of these bits is translated into distance from the PHY.
7:0	TDR_PEAKE_LOC_C_0	0, RO	Location of the first peak discovered by the TDR mechanism on channel C. The value of these bits is translated into distance from the PHY.

**8.6.97 TDR Peak Locations Register 7 (TDR\_PEAKE\_LOC\_7)**
**Table 107. TDR Peak Locations Register 7 (TDR\_PEAKE\_LOC\_7), Address 0x0196**

BIT	BIT NAME	DEFAULT	DESCRIPTION
15:8	TDR_PEAKE_LOC_C_3	0, RO	Location of the fourth peak discovered by the TDR mechanism on channel C. The value of these bits is translated into distance from the PHY.
7:0	TDR_PEAKE_LOC_C_2	0, RO	Location of the third peak discovered by the TDR mechanism on channel C. The value of these bits is translated into distance from the PHY.

**8.6.98 TDR Peak Locations Register 8 (TDR\_PEAKE\_LOC\_8)**
**Table 108. TDR Peak Locations Register 8 (TDR\_PEAKE\_LOC\_8), Address 0x0197**

BIT	BIT NAME	DEFAULT	DESCRIPTION
15:8	TDR_PEAKE_LOC_D_0	0, RO	Location of the first peak discovered by the TDR mechanism on channel D. The value of these bits is translated into distance from the PHY.
7:0	TDR_PEAKE_LOC_C_4	0, RO	Location of the fifth peak discovered by the TDR mechanism on channel C. The value of these bits is translated into distance from the PHY.

**8.6.99 TDR Peak Locations Register 9 (TDR\_PEAKE\_LOC\_9)**
**Table 109. TDR Peak Locations Register 9 (TDR\_PEAKE\_LOC\_9), Address 0x0198**

BIT	BIT NAME	DEFAULT	DESCRIPTION
15:8	TDR_PEAKE_LOC_D_2	0, RO	Location of the third peak discovered by the TDR mechanism on channel D. The value of these bits is translated into distance from the PHY.
7:0	TDR_PEAKE_LOC_D_1	0, RO	Location of the second peak discovered by the TDR mechanism on channel D. The value of these bits is translated into distance from the PHY.

**8.6.100 TDR Peak Locations Register 10 (TDR\_PEAKE\_LOC\_10)**
**Table 110. TDR Peak Locations Register 10 (TDR\_PEAKE\_LOC\_10), Address 0x0199**

BIT	BIT NAME	DEFAULT	DESCRIPTION
15:8	TDR_PEAKE_LOC_D_4	0, RO	Location of the fifth peak discovered by the TDR mechanism on channel D. The value of these bits is translated into distance from the PHY.
7:0	TDR_PEAKE_LOC_D_3	0, RO	Location of the fourth peak discovered by the TDR mechanism on channel D. The value of these bits is translated into distance from the PHY.

**8.6.101 TDR Peak Amplitudes Register 1 (TDR\_PEAKE\_AMP\_1)**
**Table 111. TDR Peak Amplitudes Register 1 (TDR\_PEAKE\_AMP\_1), Address 0x019A**

BIT	BIT NAME	DEFAULT	DESCRIPTION
15	RESERVED	0, RO	RESERVED
14:8	TDR_PEAKE_AMP_A_1	0, RO	Amplitude of the second peak discovered by the TDR mechanism on channel A. The value of these bits is translated into type of cable fault and-or interference.
7	RESERVED	0, RO	RESERVED
6:0	TDR_PEAKE_AMP_A_0	0, RO	Amplitude of the first peak discovered by the TDR mechanism on channel A. The value of these bits is translated into type of cable fault and-or interference.

**8.6.102 TDR Peak Amplitudes Register 2 (TDR\_PEAKE\_AMP\_2)**
**Table 112. TDR Peak Amplitudes Register 2 (TDR\_PEAKE\_AMP\_2), Address 0x019B**

BIT	BIT NAME	DEFAULT	DESCRIPTION
15	RESERVED	0, RO	RESERVED
14:8	TDR_PEAKE_AMP_A_3	0, RO	Amplitude of the fourth peak discovered by the TDR mechanism on channel A. The value of these bits is translated into type of cable fault and-or interference.

**Table 112. TDR Peak Amplitudes Register 2 (TDR\_PEAKS\_AMP\_2), Address 0x019B (continued)**

BIT	BIT NAME	DEFAULT	DESCRIPTION
7	RESERVED	0, RO	RESERVED
6:0	TDR_PEAKS_AMP_A_2	0, RO	Amplitude of the third peak discovered by the TDR mechanism on channel A. The value of these bits is translated into type of cable fault and-or interference.

**8.6.103 TDR Peak Amplitudes Register 3 (TDR\_PEAKS\_AMP\_3)**
**Table 113. TDR Peak Amplitudes Register 3 (TDR\_PEAKS\_AMP\_3), Address 0x019C**

BIT	BIT NAME	DEFAULT	DESCRIPTION
15	RESERVED	0, RO	RESERVED
14:8	TDR_PEAKS_AMP_B_0	0, RO	Amplitude of the first peak discovered by the TDR mechanism on channel B. The value of these bits is translated into type of cable fault and-or interference.
7	RESERVED	0, RO	RESERVED
6:0	TDR_PEAKS_AMP_A_4	0, RO	Amplitude of the fifth peak discovered by the TDR mechanism on channel A. The value of these bits is translated into type of cable fault and-or interference.

**8.6.104 TDR Peak Amplitudes Register 4 (TDR\_PEAKS\_AMP\_4)**
**Table 114. TDR Peak Amplitudes Register 4 (TDR\_PEAKS\_AMP\_4), Address 0x019D**

BIT	BIT NAME	DEFAULT	DESCRIPTION
15	RESERVED	0, RO	RESERVED
14:8	TDR_PEAKS_AMP_B_2	0, RO	Amplitude of the third peak discovered by the TDR mechanism on channel B. The value of these bits is translated into type of cable fault and-or interference.
7	RESERVED	0, RO	RESERVED
6:0	TDR_PEAKS_AMP_B_1	0, RO	Amplitude of the second peak discovered by the TDR mechanism on channel B. The value of these bits is translated into type of cable fault and-or interference.

**8.6.105 TDR Peak Amplitudes Register 5 (TDR\_PEAKS\_AMP\_5)**
**Table 115. TDR Peak Amplitudes Register 5 (TDR\_PEAKS\_AMP\_5), Address 0x019E**

BIT	BIT NAME	DEFAULT	DESCRIPTION
15	RESERVED	0, RO	RESERVED
14:8	TDR_PEAKS_AMP_B_4	0, RO	Amplitude of the fifth peak discovered by the TDR mechanism on channel B. The value of these bits is translated into type of cable fault and-or interference.
7	RESERVED	0, RO	RESERVED
6:0	TDR_PEAKS_AMP_B_3	0, RO	Amplitude of the fourth peak discovered by the TDR mechanism on channel B. The value of these bits is translated into type of cable fault and-or interference.

**8.6.106 TDR Peak Amplitudes Register 6 (TDR\_PEAKS\_AMP\_6)**
**Table 116. TDR Peak Amplitudes Register 6 (TDR\_PEAKS\_AMP\_6), Address 0x019F**

BIT	BIT NAME	DEFAULT	DESCRIPTION
15	RESERVED	0, RO	RESERVED

**Table 116. TDR Peak Amplitudes Register 6 (TDR\_PEAKE\_AMP\_6), Address 0x019F (continued)**

BIT	BIT NAME	DEFAULT	DESCRIPTION
14:8	TDR_PEAKE_AMP_C_1	0, RO	Amplitude of the second peak discovered by the TDR mechanism on channel C. The value of these bits is translated into type of cable fault and-or interference.
7	RESERVED	0, RO	RESERVED
6:0	TDR_PEAKE_AMP_C_0	0, RO	Amplitude of the first peak discovered by the TDR mechanism on channel C. The value of these bits is translated into type of cable fault and-or interference.

**8.6.107 TDR Peak Amplitudes Register 7 (TDR\_PEAKE\_AMP\_7)**
**Table 117. TDR Peak Amplitudes Register 7 (TDR\_PEAKE\_AMP\_7), Address 0x01A0**

BIT	BIT NAME	DEFAULT	DESCRIPTION
15	RESERVED	0, RO	RESERVED
14:8	TDR_PEAKE_AMP_C_3	0, RO	Amplitude of the fourth peak discovered by the TDR mechanism on channel C. The value of these bits is translated into type of cable fault and-or interference.
7	RESERVED	0, RO	RESERVED
6:0	TDR_PEAKE_AMP_C_2	0, RO	Amplitude of the third peak discovered by the TDR mechanism on channel C. The value of these bits is translated into type of cable fault and-or interference.

**8.6.108 TDR Peak Amplitudes Register 8 (TDR\_PEAKE\_AMP\_8)**
**Table 118. TDR Peak Amplitudes Register 8 (TDR\_PEAKE\_AMP\_8), Address 0x01A1**

BIT	BIT NAME	DEFAULT	DESCRIPTION
15	RESERVED	0, RO	RESERVED
14:8	TDR_PEAKE_AMP_D_0	0, RO	Amplitude of the first peak discovered by the TDR mechanism on channel D. The value of these bits is translated into type of cable fault and-or interference.
7	RESERVED	0, RO	RESERVED
6:0	TDR_PEAKE_AMP_C_4	0, RO	Amplitude of the fifth peak discovered by the TDR mechanism on channel C. The value of these bits is translated into type of cable fault and-or interference.

**8.6.109 TDR Peak Amplitudes Register 9 (TDR\_PEAKE\_AMP\_9)**
**Table 119. TDR Peak Amplitudes Register 9 (TDR\_PEAKE\_AMP\_9), Address 0x01A2**

BIT	BIT NAME	DEFAULT	DESCRIPTION
15	RESERVED	0, RO	RESERVED
14:8	TDR_PEAKE_AMP_D_2	0, RO	Amplitude of the third peak discovered by the TDR mechanism on channel D. The value of these bits is translated into type of cable fault and-or interference.
7	RESERVED	0, RO	RESERVED
6:0	TDR_PEAKE_AMP_D_1	0, RO	Amplitude of the second peak discovered by the TDR mechanism on channel D. The value of these bits is translated into type of cable fault and-or interference.

**8.6.110 TDR Peak Amplitudes Register 10 (TDR\_PEAKS\_AMP\_10)**
**Table 120. TDR Peak Amplitudes Register 10 (TDR\_PEAKS\_AMP\_10), Address 0x01A3**

BIT	BIT NAME	DEFAULT	DESCRIPTION
15	RESERVED	0, RO	RESERVED
14:8	TDR_PEAKS_AMP_D_4	0, RO	Amplitude of the fifth peak discovered by the TDR mechanism on channel D. The value of these bits is translated into type of cable fault and-or interference.
7	RESERVED	0, RO	RESERVED
6:0	TDR_PEAKS_AMP_D_3	0, RO	Amplitude of the fourth peak discovered by the TDR mechanism on channel D. The value of these bits is translated into type of cable fault and-or interference.

**8.6.111 TDR General Status (TDR\_GEN\_STATUS)**
**Table 121. TDR General Status (TDR\_GEN\_STATUS), Address 0x01A4**

BIT	BIT NAME	DEFAULT	DESCRIPTION
15:12	RESERVED	0, RO	RESERVED
11	TDR_P_LOC_CROSS_MODE_D	0, RO	Cross Detect on Channel D: 1 = Cross reflection detected on channel D. Indicates a short between channels. 0 = No cross reflection detected.
10	TDR_P_LOC_CROSS_MODE_C	0, RO	Cross Detect on Channel C: 1 = Cross reflection detected on channel C. Indicates a short between channels. 0 = No cross reflection detected.
9	TDR_P_LOC_CROSS_MODE_B	0, RO	Cross Detect on Channel B: 1 = Cross reflection detected on channel B. Indicates a short between channels. 0 = No cross reflection detected.
8	TDR_P_LOC_CROSS_MODE_A	0, RO	Cross Detect on Channel A: 1 = Cross reflection detected on channel A. Indicates a short between channels. 0 = No cross reflection detected.
7	TDR_P_LOC_OVERFLOW_D	0, RO	Peak Overflow on Channel D: 1 = More than 5 reflections were detected on channel D. 0 = Normal operation.
6	TDR_P_LOC_OVERFLOW_C	0, RO	Peak Overflow on Channel C: 1 = More than 5 reflections were detected on channel C. 0 = Normal operation.
5	TDR_P_LOC_OVERFLOW_B	0, RO	Peak Overflow on Channel B: 1 = More than 5 reflections were detected on channel B. 0 = Normal operation.
4	TDR_P_LOC_OVERFLOW_A	0, RO	Peak Overflow on Channel A: 1 = More than 5 reflections were detected on channel A. 0 = Normal operation.
3:0	RESERVED	0, RO	RESERVED

**8.6.112 Advanced Link Cable Diagnostics Control Register (ALCD\_CTRL)**
**Table 122. Advanced Link Cable Diagnostics Control Register (ALCD\_CTRL), Address 0x01A7**

BIT	BIT NAME	DEFAULT	DESCRIPTION
15:8	ALCD_SUM	0000 0000, RO	ALCD result
7:6	RESERVED	0, RO	RESERVED
5	ALCD_SUM_DONE	0, RO	ALCD Complete: 1 = ALCD process has completed. 0 = ALCD process has not completed.
4	ALCD_CLEAR	0, RW, SC	Clear ALCD: 1 = Reset the ALCD results.
3:0	RESERVED	0, RO	RESERVED

## 9 Application and Implementation

### NOTE

Information in the following applications sections is not part of the TI component specification, and TI does not warrant its accuracy or completeness. TI's customers are responsible for determining suitability of components for their purposes. Customers should validate and test their design implementation to confirm system functionality.

### 9.1 Application Information

The DP83867 is a single port 10/100/1000 Ethernet PHY. It supports connections to an Ethernet MAC via RGMII or GMII. Connections to the Ethernet media are made via the IEEE 802.3 defined Media Dependent Interface. DP83867IRRGZ/CRRGZ support only RGMII.

When using the device for Ethernet application, it is necessary to meet certain requirements for normal operation of the device. The following typical application and design requirements can be used for selecting appropriate component values for DP83867.

### 9.2 Typical Application

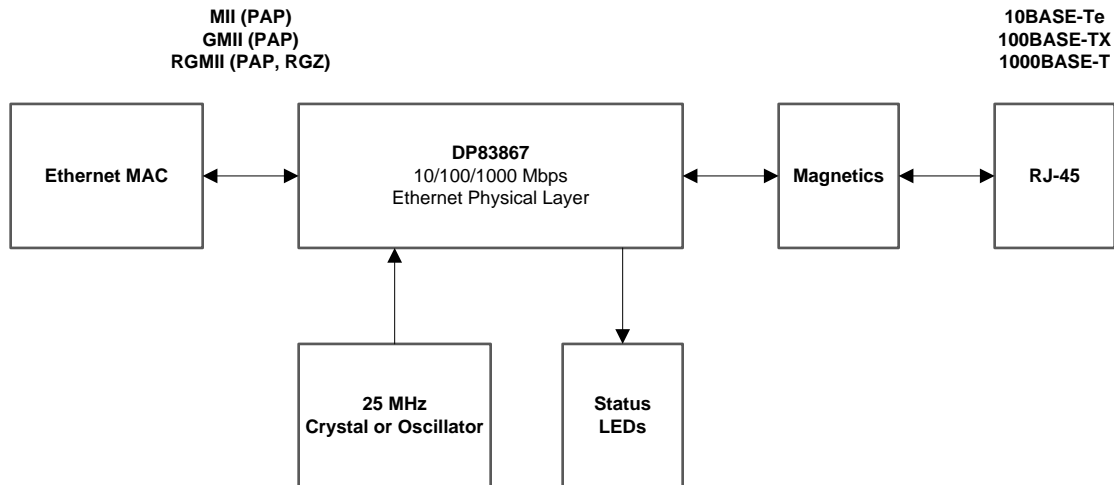

**Figure 29. Typical DP83867 Application**

#### 9.2.1 Design Requirements

The design requirements for the DP83867 are:

- VDDA2P5 = 2.5 V
- VDD1P1 (PAP) = 1.1 V
- VDD1P0 (RGZ) = 1.0 V
- VDDIO = 3.3 V, 2.5 V, or 1.8 V
- Clock Input = 25 MHz

**Typical Application (continued)**

**9.2.1.1 Cable Line Driver**

The line driver implementation is designed to support simple connections to the transformer and the connector. The DP83867 includes integrated terminations so no external termination resistors are required.

The connection diagram for the cable line driver is shown in [Figure 30](#).

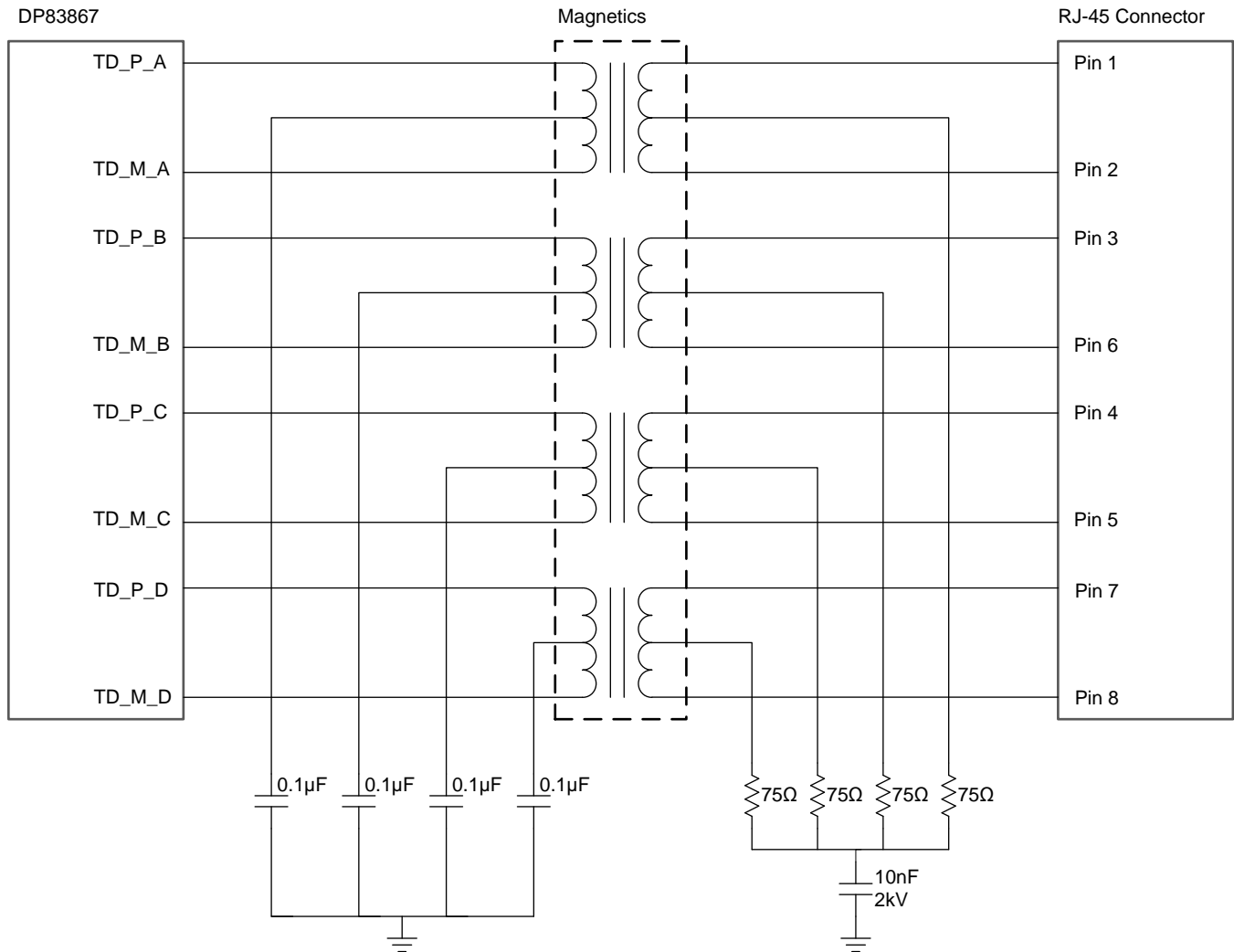

**Figure 30. Magnetics Connections**

## Typical Application (continued)

### 9.2.1.2 Clock In (XI) Recommendation

If an external clock source is used, XO should be left floating. For a 1.8-V clock source, XI should be tied to the clock source. For a 3.3-V or 2.5-V clock source, a capacitor divider is recommended as shown in [Figure 31](#). The recommended values for the C1 and C2 capacitors is 27 pF.

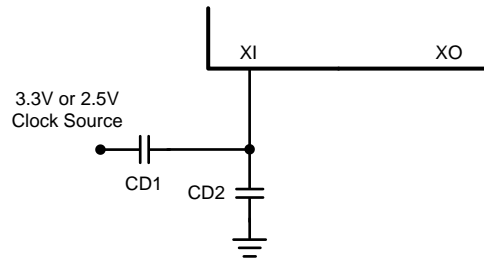

Figure 31. Clock Divider

The CMOS 25-MHz oscillator specifications are listed in [Table 123](#).

Table 123. 25-MHz Oscillator Specifications

PARAMETER	TEST CONDITION	MIN	TYP	MAX	UNIT
Frequency			25		MHz
Frequency Tolerance	Operational Temperature			±50	ppm
Frequency Stability	1 year aging			±50	ppm
Rise / Fall Time	20% - 80%			5	ns
Symmetry	Duty Cycle	40%		60%	

### 9.2.1.3 Crystal Recommendations

A 25-MHz, parallel, 18-pF load crystal resonator should be used if a crystal source is desired. [Figure 32](#) shows a typical connection for a crystal resonator circuit. The load capacitor values vary with the crystal vendors; check with the vendor for the recommended loads.

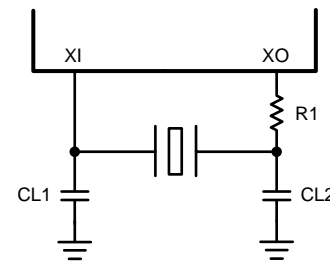

Figure 32. Crystal Oscillator Circuit

As a starting point for evaluating an oscillator circuit, if the requirements for the crystal are not known, CL1 and CL2 should be set at 27 pF, and R1 should be set at 0 Ω.

Specification for 25-MHz crystal are listed in [Table 124](#).

Table 124. 25-MHz Crystal Specifications

PARAMETER	TEST CONDITION	MIN	TYP	MAX	UNIT
Frequency			25		MHz
Frequency Tolerance	Operational Temperature			±50	ppm
Frequency Stability	1 year aging			±50	ppm

## 9.2.2 Detailed Design Procedure

### 9.2.2.1 MAC Interface

The Media Independent Interface (RGMII / GMII) connects the DP83867 to the Media Access Controller (MAC). The MAC may in fact be a discrete device, integrated into a microprocessor, CPU or FPGA.

#### 9.2.2.1.1 RGMII Layout Guidelines

- RGMII signals are single-ended signals.
- Traces must be routed with impedance of 50  $\Omega$  to ground.
- Skew between TXD[3:0] lines should be less than 11 ps, which correlates to 60 mil for standard FR4.
- Skew between RXD[3:0] lines should be less than 11 ps, which correlates to 60 mil for standard FR4.
- Keep trace lengths as short as possible; less than 2 inches is recommended with less than 6 inches as maximum length.
- Configurable clock skew for GTX\_CLK and RX\_CLK.
  - Clock skew for RX and TX paths can be optimized independently.
  - Clock skew is adjustable in 0.25-ns increments (through register).

#### 9.2.2.1.2 GMII Layout Guidelines

- GMII signals are single-ended signals.
- Traces should be routed with impedance of 50  $\Omega$  to ground.
- Keep trace lengths as short as possible, less than 2 inches recommended, less than 6 inches maximum length.

### 9.2.2.2 Media Dependent Interface (MDI)

The Media Dependent Interface (MDI) connects the DP83867 to the transformer and the Ethernet network.

#### 9.2.2.2.1 MDI Layout Guidelines

- MDI traces must be 50  $\Omega$  to ground and 100  $\Omega$ -differential controlled impedance.
- Route MDI traces to transformer on the same layer.
- Use a metal shielded RJ-45 connector, and connect the shield to chassis ground.
- Use magnetics with integrated common-mode choking devices.
- Void supplies and ground beneath magnetics.
- Do not overlap the circuit and chassis ground planes, keep them isolated. Instead, make chassis ground an isolated island and make a void between the chassis and circuit ground. Connecting circuit and chassis planes using a size 1206 resistor and capacitor on either side of the connector is a good practice.

## 9.2.3 Application Curves

[Table 125](#) lists the application curves for this application.

**Table 125. Table of Graphs**

TITLE	FIGURE
1000Base-T Signaling	<a href="#">Figure 13</a>
100Base-TX Signaling	<a href="#">Figure 14</a>

## 10 Power Supply Recommendations

The DP83867 is capable of operating with as few as two or three supplies. The I/O power supply can also be operated independently of the main device power supplies to provide flexibility for the MAC interface.

For detailed information about DP83867 power consumption for specific supplies under a wide set of conditions, see the [DP83867E/IS/CS/IR/CR RGZ Power Consumption Data](#) application report (SNLA241).

The connection diagrams for the two-supply and three-supply configurations are shown in [Figure 33](#) and [Figure 34](#).

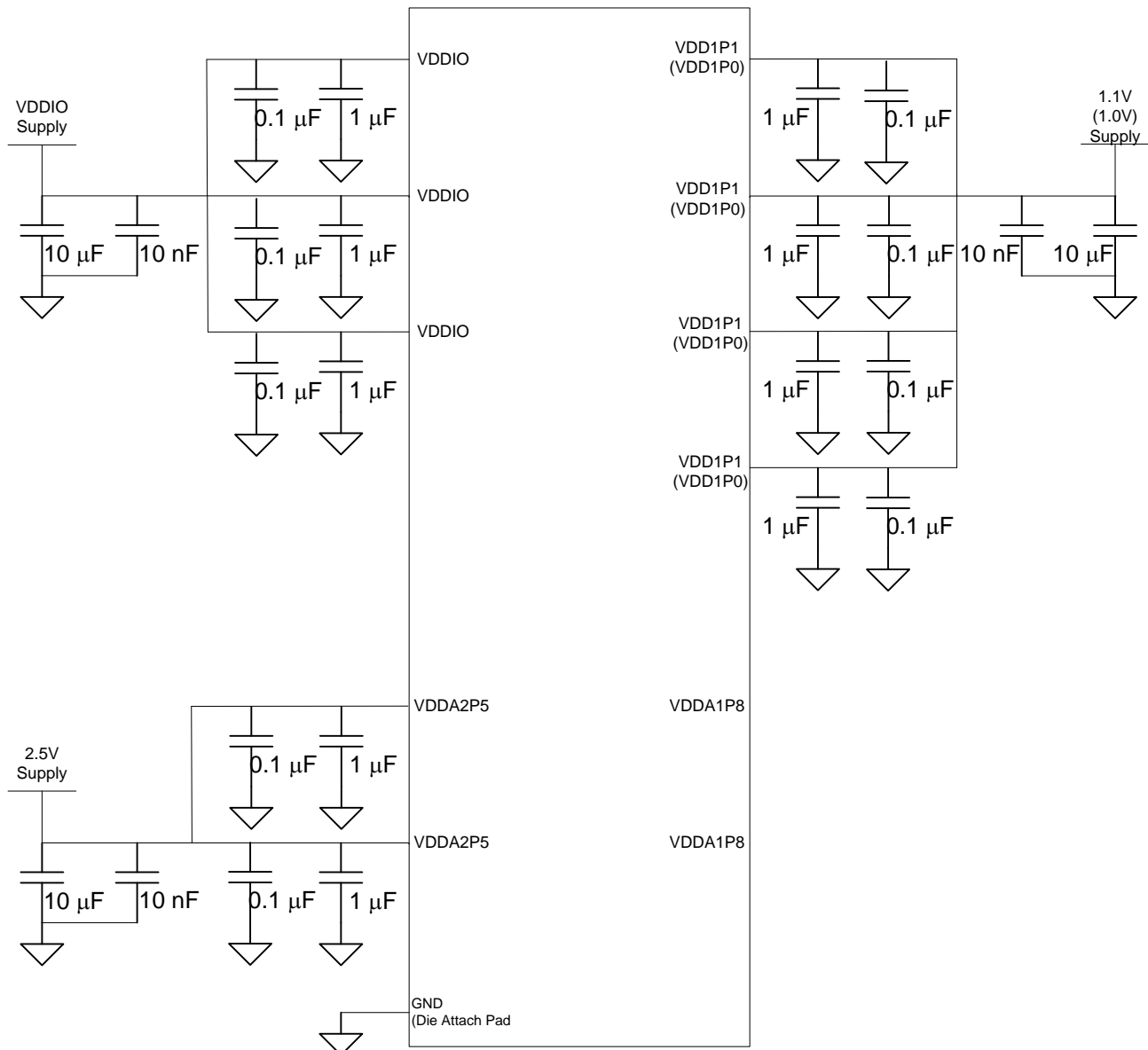

For two supply configuration, both VDDA1P8 pins must be left unconnected.

RGZ devices support 1.0V on VDD1P0 pins

Place 1µF decoupling capacitors as close as possible to component VDD pins.

VDDIO may be 3.3 V or 2.5 V or 1.8 V.

No Components should be connected to VDDA1P8 pins in Two Supply Configuration.

**Figure 33. Two Supply Configuration**

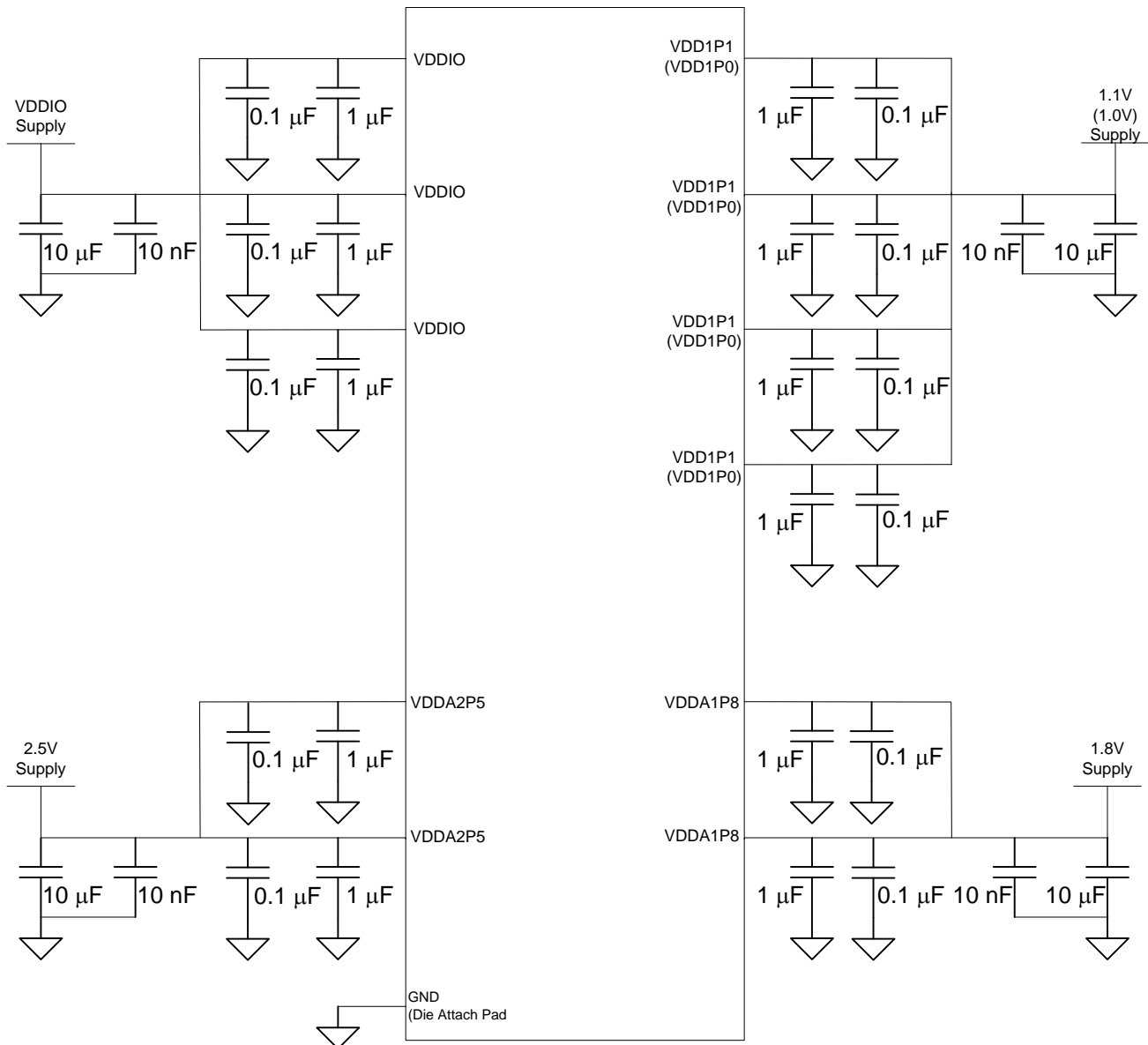

Place 1µF decoupling capacitors as close as possible to component VDD pins.

RGZ devices support 1.0V on VDD1P0 pins

Note: VDDIO may be 3.3 V or 2.5 V or 1.8 V.

**Figure 34. Three Supply Configuration**

There is no requirement for the sequence of the supplies when operating in two-supply mode.

When operating in three-supply mode, the 1.8-V VDDA1P8 supply must be stable within 25 ms of the 2.5-V VDDA2P5 supply ramping up. There is no sequencing requirement for other supplies when operating in three-supply mode.

When powering down the DP83867, the 1.8-V supply should be brought down before the 2.5-V supply.

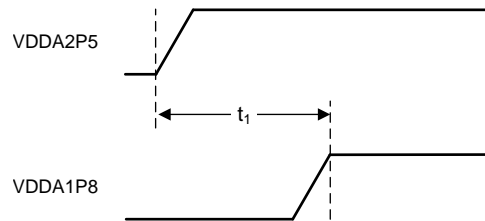

Figure 35. Three-Supply Mode Power Supply Sequence Diagram

Table 126. Three-Supply Mode Power Supply Sequence

PARAMETER	TEST CONDITIONS	MIN	NOM	MAX	UNIT
T1	Beginning of VDDA2P5 ramp up to VDDA1P8 stable	0		25	ms

**NOTE**

If the 2.5-V power supply provides power to DP83867 devices only, the 1.8-V supply may ramp up any time before 2.5-V.

## 11 Layout

### 11.1 Layout Guidelines

#### 11.1.1 Signal Traces

PCB traces are lossy and long traces can degrade the signal quality. Traces must be kept short as possible. Unless mentioned otherwise, all signal traces should be 50-Ω, single-ended impedance. Differential traces should be 50-Ω, single-ended and 100-Ω differential. Take care that the impedance is constant throughout. Impedance discontinuities cause reflections leading to EMI & signal integrity problems. Stubs must be avoided on all signal traces, especially the differential signal pairs. See [Figure 36](#)

Within the differential pairs, the trace lengths must run parallel to each other and matched in length. Matched lengths minimize delay differences, avoiding an increase in common-mode noise and increased EMI.

Length matching is also important on MAC interface. All Transmit signal trace lengths must match to each other and all Receive signal trace lengths must match to each other.

Ideally, there should be no crossover or via on the signal paths. Vias present impedance discontinuities and should be minimized. Route an entire trace pair on a single layer if possible.

## Layout Guidelines (continued)

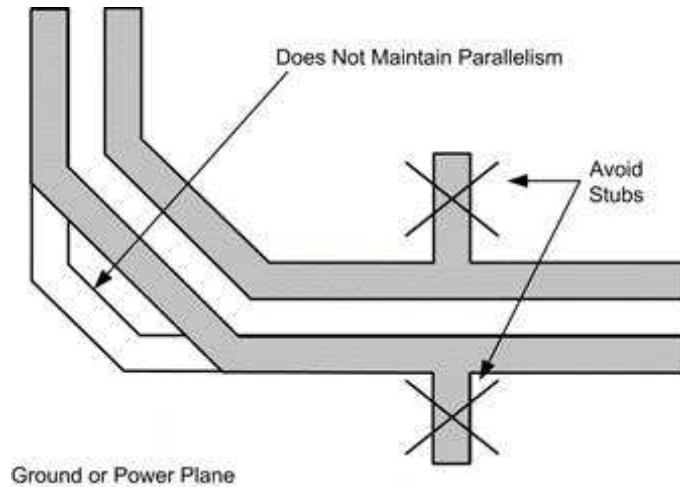

**Figure 36. Avoiding Stubs in a Differential Signal Pair**

Signals on different layers should not cross each other without at least one return path plane between them.

Coupling between traces is also an important factor. Unwanted coupling can cause cross talk problems. Differential pairs on the other hand, should have a constant coupling distance between them.

For convenience and efficient layout process, start by routing the critical signals first.

### 11.1.2 Return Path

A general best practice is to have a solid return path beneath all signal traces. This return path can be a continuous ground or DC power plane. Reducing the width of the return path width can potentially affect the impedance of the signal trace. This effect is more prominent when the width of the return path is comparable to the width of the signal trace. Breaks in return path beneath the signal traces should be avoided at all cost. A signal crossing a plane split may cause unpredictable return path currents and would likely impact signal quality as well, potentially creating EMI problems. See [Figure 37](#)

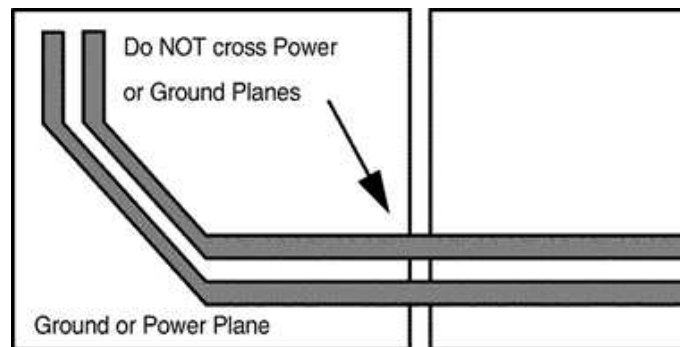

**Figure 37. Differential Signal Pair-Plane Crossing**

### 11.1.3 Transformer Layout

There should be no metal layer running beneath the transformer. Transformers can inject noise in metal beneath them which can affect the performance of the system.

### 11.1.4 Metal Pour

All metal pours which are not signals or power should be tied to ground. There should be no floating metal on the system. There should be no metal between the differential traces.

## Layout Guidelines (continued)

### 11.1.5 PCB Layer Stacking

To meet signal integrity and performance requirements, at minimum a 4-layer PCB should be used. However a 6-layer board is recommended. See [Figure 38](#) for the recommended layer stack ups for 4, 6 and 8-layer boards. These are recommendations not requirements, other configurations can be used as per system requirements.

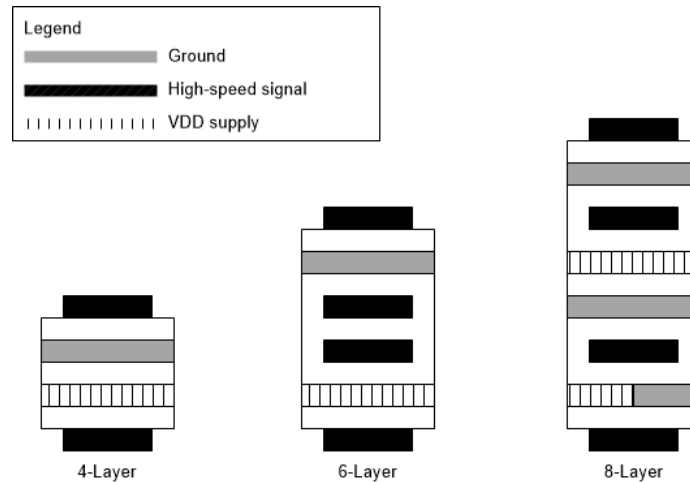

**Figure 38. Recommended Layer Stack Up**

Within a PCB, it may be desirable to run traces using different methods, microstrip vs. stripline, depending on the location of the signal on the PCB. For example, it may be desirable to change layer stacking where an isolated chassis ground plane is used. [Figure 39](#) illustrates alternative PCB stacking options.

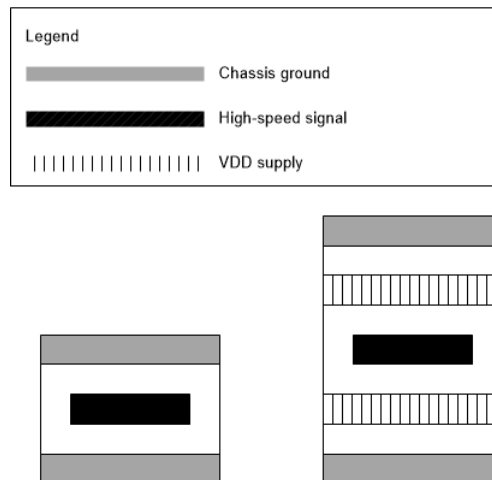

**Figure 39. Alternative Layer Stack Up**

## 11.2 Layout Example

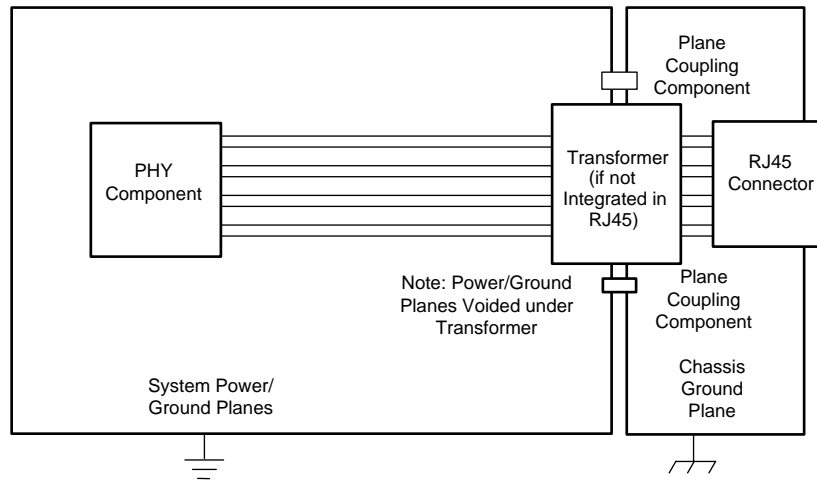

**Figure 40. Layout Example**

## 12 Device and Documentation Support

### 12.1 Documentation Support

#### 12.1.1 Related Documentation

For related documentation, see the following:

- [DP83867 Troubleshooting Guide](#) (SNLA246)
- [How to Configure DP838XX for Ethernet Compliance Testing](#) (SNLA239)
- [Configuring Ethernet Devices with 4-Level Straps](#) (SNLA258)
- [RGMII Interface Timing Budgets](#) (SNLA243)
- [DP83867E/IS/CS/IR/CR RGZ Power Consumption Data](#) (SNLA241)
- [How to Configure DP83867 Start of Frame](#) (SNLA242)

### 12.2 Related Links

The table below lists quick access links. Categories include technical documents, support and community resources, tools and software, and quick access to order now.

**Table 127. Related Links**

PARTS	PRODUCT FOLDER	ORDER NOW	TECHNICAL DOCUMENTS	TOOLS & SOFTWARE	SUPPORT & COMMUNITY
DP83867IR	<a href="#">Click here</a>	<a href="#">Click here</a>	<a href="#">Click here</a>	<a href="#">Click here</a>	<a href="#">Click here</a>
DP83867CR	<a href="#">Click here</a>	<a href="#">Click here</a>	<a href="#">Click here</a>	<a href="#">Click here</a>	<a href="#">Click here</a>

### 12.3 Receiving Notification of Documentation Updates

To receive notification of documentation updates, navigate to the device product folder on ti.com. In the upper right corner, click on *Alert me* to register and receive a weekly digest of any product information that has changed. For change details, review the revision history included in any revised document.

### 12.4 Community Resources

The following links connect to TI community resources. Linked contents are provided "AS IS" by the respective contributors. They do not constitute TI specifications and do not necessarily reflect TI's views; see TI's [Terms of Use](#).

**TI E2E™ Online Community** *TI's Engineer-to-Engineer (E2E) Community*. Created to foster collaboration among engineers. At [e2e.ti.com](http://e2e.ti.com), you can ask questions, share knowledge, explore ideas and help solve problems with fellow engineers.

**Design Support** *TI's Design Support* Quickly find helpful E2E forums along with design support tools and contact information for technical support.

### 12.5 Trademarks

E2E is a trademark of Texas Instruments.  
All other trademarks are the property of their respective owners.

### 12.6 Electrostatic Discharge Caution



These devices have limited built-in ESD protection. The leads should be shorted together or the device placed in conductive foam during storage or handling to prevent electrostatic damage to the MOS gates.

### 12.7 Glossary

**SLYZ022** — *TI Glossary*.

This glossary lists and explains terms, acronyms, and definitions.

### 13 Mechanical, Packaging, and Orderable Information

The following pages include mechanical, packaging, and orderable information. This information is the most current data available for the designated devices. This data is subject to change without notice and revision of this document. For browser-based versions of this data sheet, refer to the left-hand navigation.

**PACKAGING INFORMATION**

Orderable Device	Status (1)	Package Type	Package Drawing	Pins	Package Qty	Eco Plan (2)	Lead/Ball Finish (6)	MSL Peak Temp (3)	Op Temp (°C)	Device Marking (4/5)	Samples
DP83867CRRGZR	ACTIVE	VQFN	RGZ	48	2500	Green (RoHS & no Sb/Br)	CU NIPDAU	Level-3-260C-168 HR	0 to 70	DP83867CR	<a href="#">Samples</a>
DP83867CRRGZT	ACTIVE	VQFN	RGZ	48	250	Green (RoHS & no Sb/Br)	CU NIPDAU	Level-3-260C-168 HR	0 to 70	DP83867CR	<a href="#">Samples</a>
DP83867IRPAPR	ACTIVE	HTQFP	PAP	64	1000	Green (RoHS & no Sb/Br)	CU NIPDAU	Level-3-260C-168 HR	-40 to 85	DP83867IR	<a href="#">Samples</a>
DP83867IRPAPT	ACTIVE	HTQFP	PAP	64	250	Green (RoHS & no Sb/Br)	CU NIPDAU	Level-3-260C-168 HR	-40 to 85	DP83867IR	<a href="#">Samples</a>
DP83867IRRGZR	ACTIVE	VQFN	RGZ	48	2500	Green (RoHS & no Sb/Br)	CU NIPDAU	Level-3-260C-168 HR	-40 to 85	DP83867IR	<a href="#">Samples</a>
DP83867IRRGZT	ACTIVE	VQFN	RGZ	48	250	Green (RoHS & no Sb/Br)	CU NIPDAU	Level-3-260C-168 HR	-40 to 85	DP83867IR	<a href="#">Samples</a>

(1) The marketing status values are defined as follows:

**ACTIVE:** Product device recommended for new designs.

**LIFEBUY:** TI has announced that the device will be discontinued, and a lifetime-buy period is in effect.

**NRND:** Not recommended for new designs. Device is in production to support existing customers, but TI does not recommend using this part in a new design.

**PREVIEW:** Device has been announced but is not in production. Samples may or may not be available.

**OBSELETE:** TI has discontinued the production of the device.

(2) Eco Plan - The planned eco-friendly classification: Pb-Free (RoHS), Pb-Free (RoHS Exempt), or Green (RoHS & no Sb/Br) - please check <http://www.ti.com/productcontent> for the latest availability information and additional product content details.

**TBD:** The Pb-Free/Green conversion plan has not been defined.

**Pb-Free (RoHS):** TI's terms "Lead-Free" or "Pb-Free" mean semiconductor products that are compatible with the current RoHS requirements for all 6 substances, including the requirement that lead not exceed 0.1% by weight in homogeneous materials. Where designed to be soldered at high temperatures, TI Pb-Free products are suitable for use in specified lead-free processes.

**Pb-Free (RoHS Exempt):** This component has a RoHS exemption for either 1) lead-based flip-chip solder bumps used between the die and package, or 2) lead-based die adhesive used between the die and leadframe. The component is otherwise considered Pb-Free (RoHS compatible) as defined above.

**Green (RoHS & no Sb/Br):** TI defines "Green" to mean Pb-Free (RoHS compatible), and free of Bromine (Br) and Antimony (Sb) based flame retardants (Br or Sb do not exceed 0.1% by weight in homogeneous material)

(3) MSL, Peak Temp. - The Moisture Sensitivity Level rating according to the JEDEC industry standard classifications, and peak solder temperature.

(4) There may be additional marking, which relates to the logo, the lot trace code information, or the environmental category on the device.

(5) Multiple Device Markings will be inside parentheses. Only one Device Marking contained in parentheses and separated by a "~" will appear on a device. If a line is indented then it is a continuation of the previous line and the two combined represent the entire Device Marking for that device.

<sup>(6)</sup> Lead/Ball Finish - Orderable Devices may have multiple material finish options. Finish options are separated by a vertical ruled line. Lead/Ball Finish values may wrap to two lines if the finish value exceeds the maximum column width.

**Important Information and Disclaimer:** The information provided on this page represents TI's knowledge and belief as of the date that it is provided. TI bases its knowledge and belief on information provided by third parties, and makes no representation or warranty as to the accuracy of such information. Efforts are underway to better integrate information from third parties. TI has taken and continues to take reasonable steps to provide representative and accurate information but may not have conducted destructive testing or chemical analysis on incoming materials and chemicals. TI and TI suppliers consider certain information to be proprietary, and thus CAS numbers and other limited information may not be available for release.

In no event shall TI's liability arising out of such information exceed the total purchase price of the TI part(s) at issue in this document sold by TI to Customer on an annual basis.

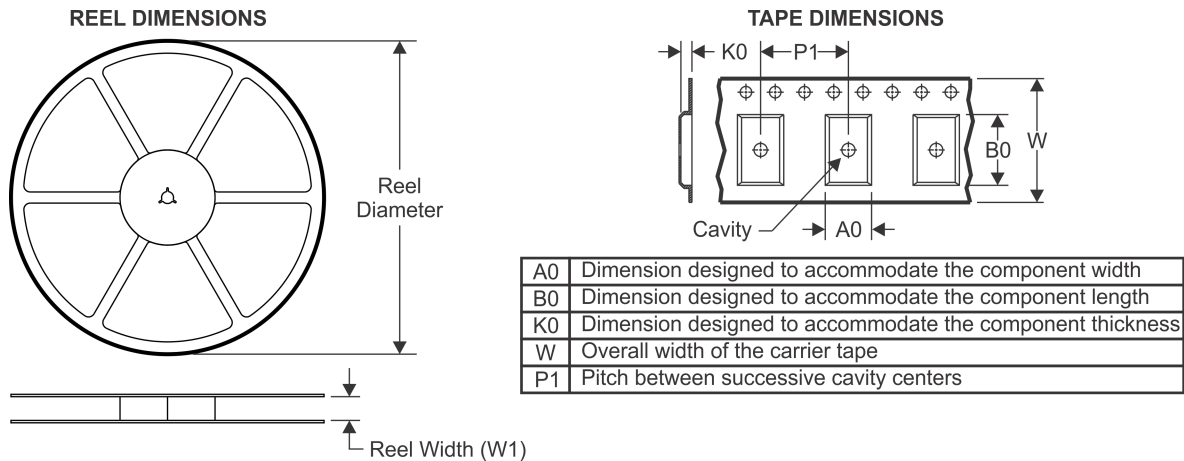
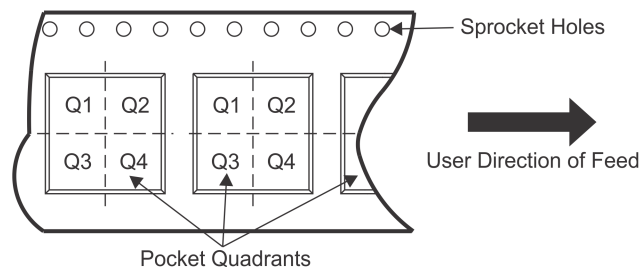
**TAPE AND REEL INFORMATION**

**QUADRANT ASSIGNMENTS FOR PIN 1 ORIENTATION IN TAPE**

\*All dimensions are nominal

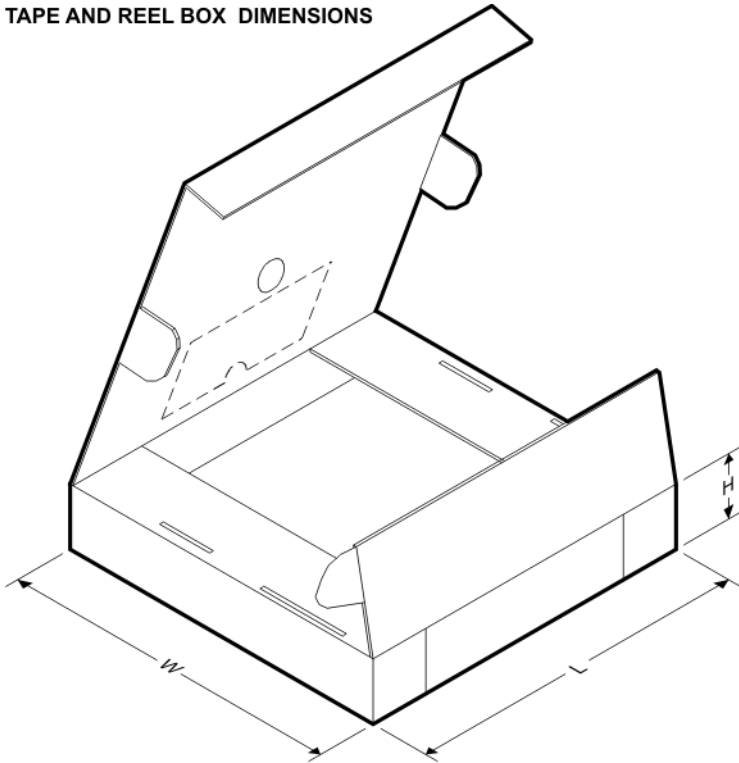
Device	Package Type	Package Drawing	Pins	SPQ	Reel Diameter (mm)	Reel Width W1 (mm)	A0 (mm)	B0 (mm)	K0 (mm)	P1 (mm)	W (mm)	Pin1 Quadrant
DP83867CRRGZR	VQFN	RGZ	48	2500	330.0	16.4	7.3	7.3	1.5	12.0	16.0	Q1
DP83867CRRGZT	VQFN	RGZ	48	250	178.0	16.4	7.3	7.3	1.5	12.0	16.0	Q1
DP83867IRPAPR	HTQFP	PAP	64	1000	330.0	24.4	13.0	13.0	1.5	16.0	24.0	Q2
DP83867IRPAPT	HTQFP	PAP	64	250	178.0	24.4	13.0	13.0	1.5	16.0	24.0	Q2
DP83867IRRGZR	VQFN	RGZ	48	2500	330.0	16.4	7.3	7.3	1.5	12.0	16.0	Q1
DP83867IRRGZT	VQFN	RGZ	48	250	178.0	16.4	7.3	7.3	1.5	12.0	16.0	Q1

**TAPE AND REEL BOX DIMENSIONS**

\*All dimensions are nominal

Device	Package Type	Package Drawing	Pins	SPQ	Length (mm)	Width (mm)	Height (mm)
DP83867CRRGZR	VQFN	RGZ	48	2500	367.0	367.0	38.0
DP83867CRRGZT	VQFN	RGZ	48	250	210.0	185.0	35.0
DP83867IRPAPR	HTQFP	PAP	64	1000	367.0	367.0	45.0
DP83867IRPAPT	HTQFP	PAP	64	250	213.0	191.0	55.0
DP83867IRRGZR	VQFN	RGZ	48	2500	367.0	367.0	38.0
DP83867IRRGZT	VQFN	RGZ	48	250	210.0	185.0	35.0

## THERMAL PAD MECHANICAL DATA

PAP (S-PQFP-G64)

PowerPAD™ PLASTIC QUAD FLATPACK

### THERMAL INFORMATION

This PowerPAD™ package incorporates an exposed thermal pad that is designed to be attached to a printed circuit board (PCB). The thermal pad must be soldered directly to the PCB. After soldering, the PCB can be used as a heatsink. In addition, through the use of thermal vias, the thermal pad can be attached directly to the appropriate copper plane shown in the electrical schematic for the device, or alternatively, can be attached to a special heatsink structure designed into the PCB. This design optimizes the heat transfer from the integrated circuit (IC).

For additional information on the PowerPAD package and how to take advantage of its heat dissipating abilities, refer to Technical Brief, PowerPAD Thermally Enhanced Package, Texas Instruments Literature No. SLMA002 and Application Brief, PowerPAD Made Easy, Texas Instruments Literature No. SLMA004. Both documents are available at [www.ti.com](http://www.ti.com).

The exposed thermal pad dimensions for this package are shown in the following illustration.

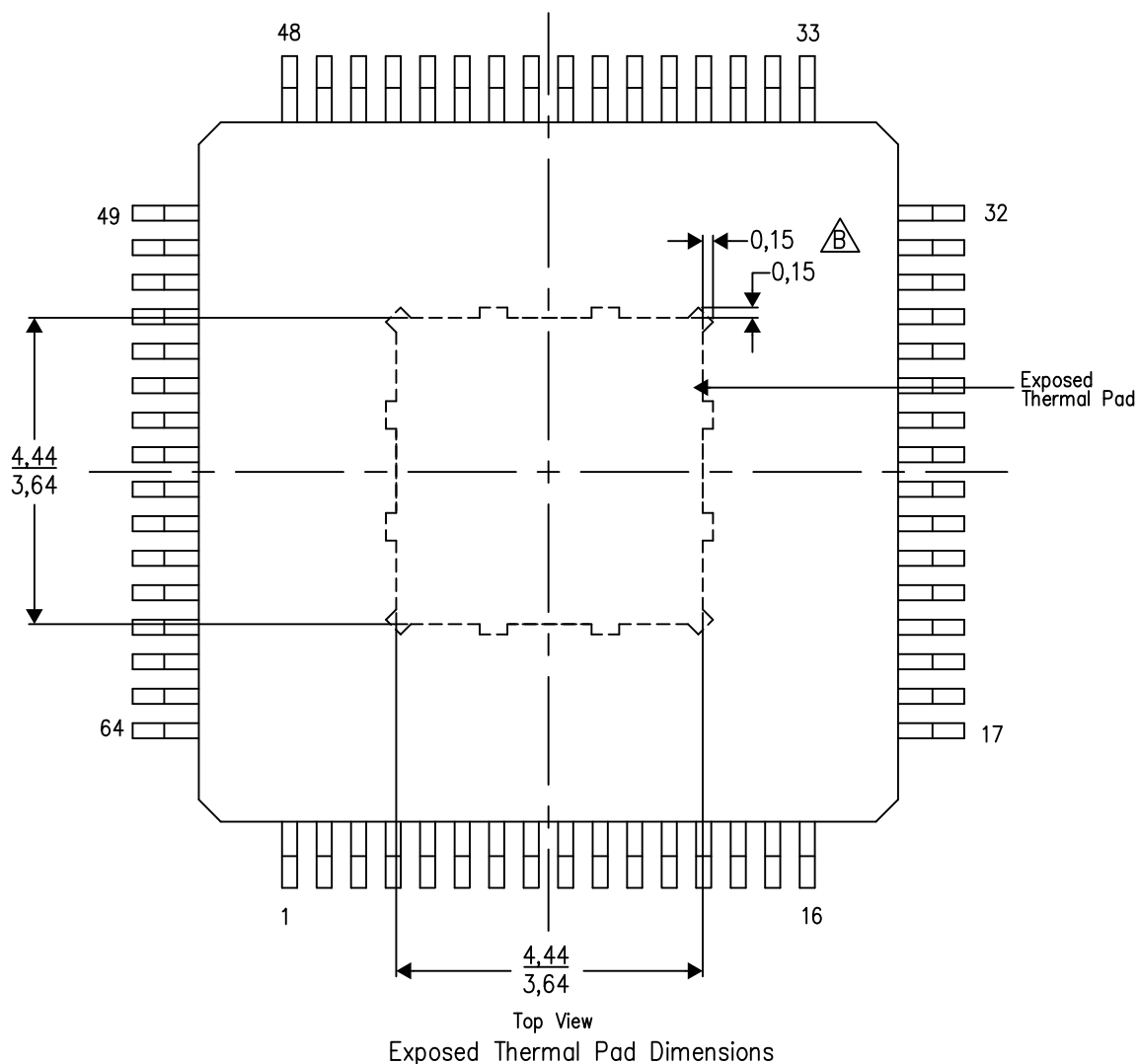

4206326-7/P 05/14

NOTES: A. All linear dimensions are in millimeters

 Tie strap features may not be present.

PowerPAD is a trademark of Texas Instruments

PAP (S-PQFP-G64)

PowerPAD™ PLASTIC QUAD FLATPACK

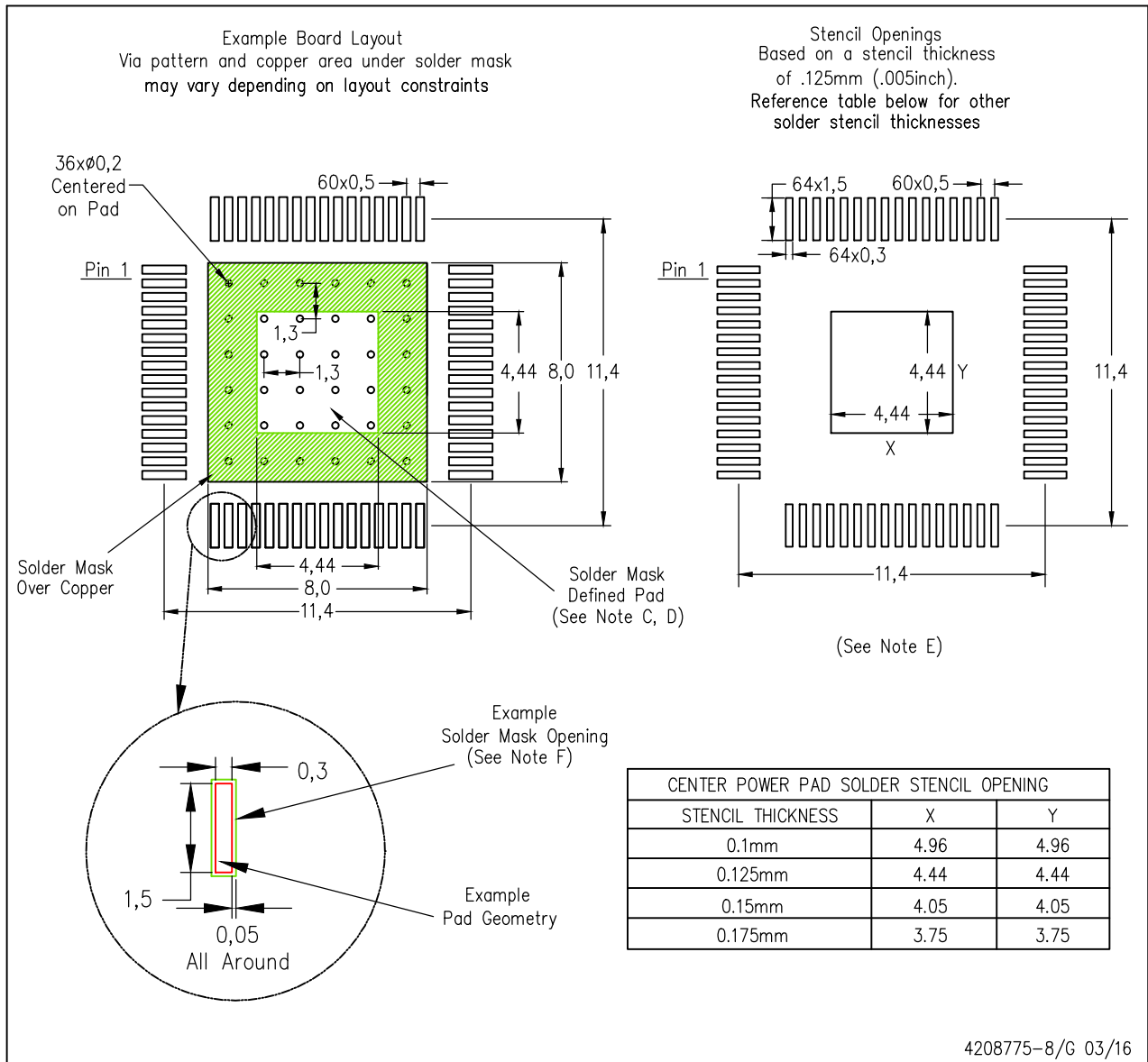

- NOTES:
- A. All linear dimensions are in millimeters.
  - B. This drawing is subject to change without notice.
  - C. Customers should place a note on the circuit board fabrication drawing not to alter the center solder mask defined pad.
  - D. This package is designed to be soldered to a thermal pad on the board. Refer to Technical Brief, PowerPad Thermally Enhanced Package, Texas Instruments Literature No. SLMA002, SLMA004, and also the Product Data Sheets for specific thermal information, via requirements, and recommended board layout. These documents are available at [www.ti.com](http://www.ti.com) <<http://www.ti.com>>. Publication IPC-7351 is recommended for alternate designs.
  - E. Laser cutting apertures with trapezoidal walls and also rounding corners will offer better paste release. Customers should contact their board assembly site for stencil design recommendations. Example stencil design based on a 50% volumetric metal load solder paste. Refer to IPC-7525 for other stencil recommendations.
  - F. Customers should contact their board fabrication site for solder mask tolerances between and around signal pads.
- PowerPAD is a trademark of Texas Instruments**

## GENERIC PACKAGE VIEW

**RGZ 48**

**VQFN - 1 mm max height**

7 x 7, 0.5 mm pitch

PLASTIC QUADFLAT PACK- NO LEAD

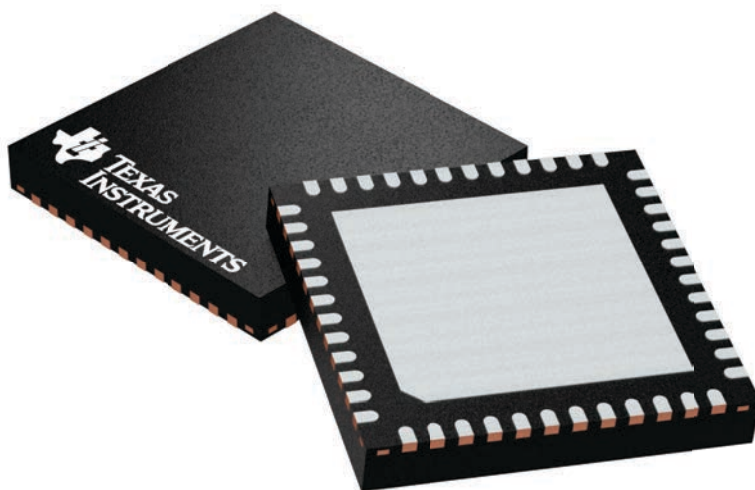

Images above are just a representation of the package family, actual package may vary.  
Refer to the product data sheet for package details.

4224671/A

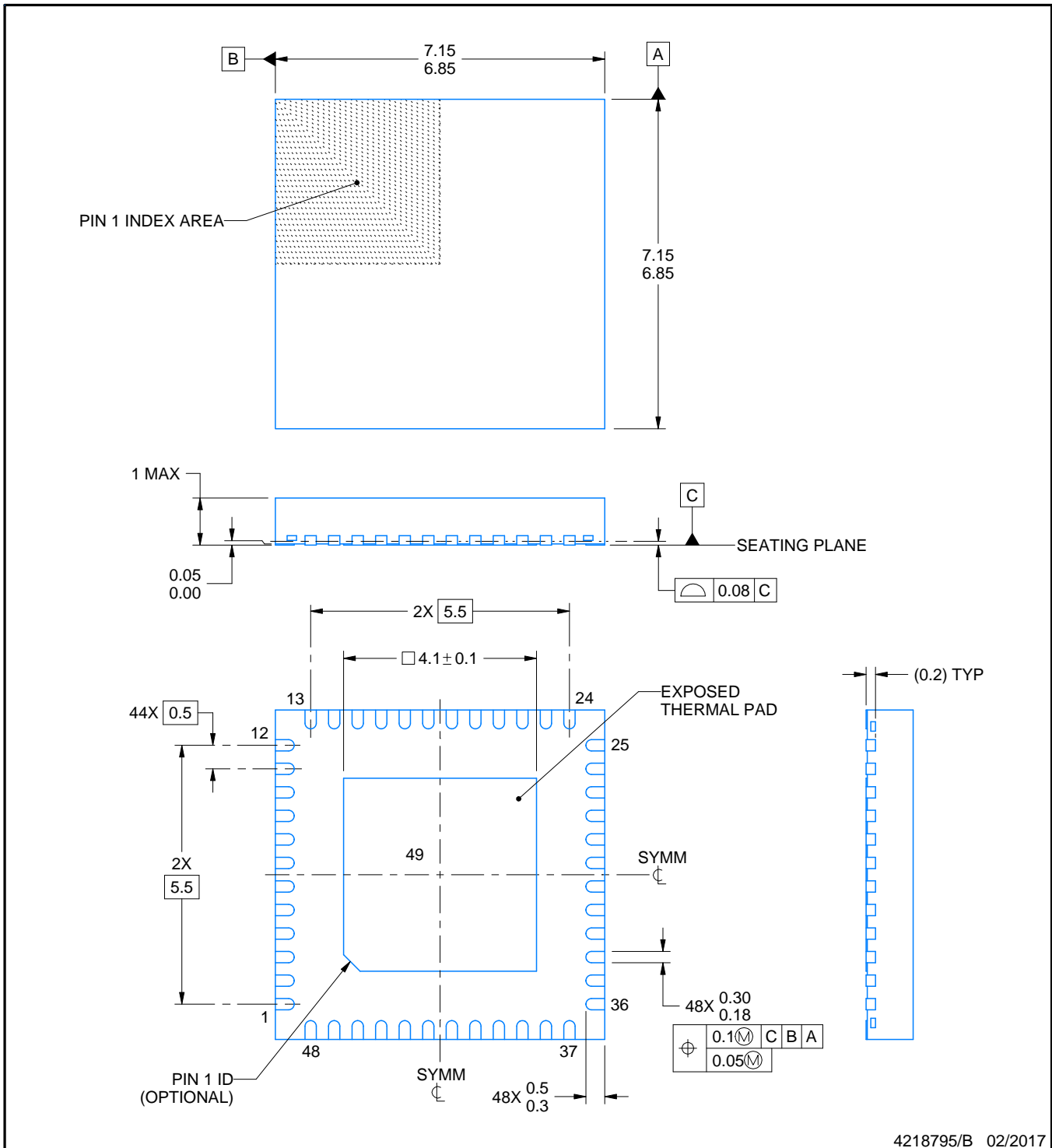
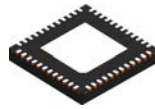

4218795/B 02/2017

NOTES:

1. All linear dimensions are in millimeters. Any dimensions in parenthesis are for reference only. Dimensioning and tolerancing per ASME Y14.5M.
2. This drawing is subject to change without notice.
3. The package thermal pad must be soldered to the printed circuit board for thermal and mechanical performance.

# EXAMPLE BOARD LAYOUT

**RGZ0048B**

**VQFN - 1 mm max height**

PLASTIC QUAD FLATPACK - NO LEAD

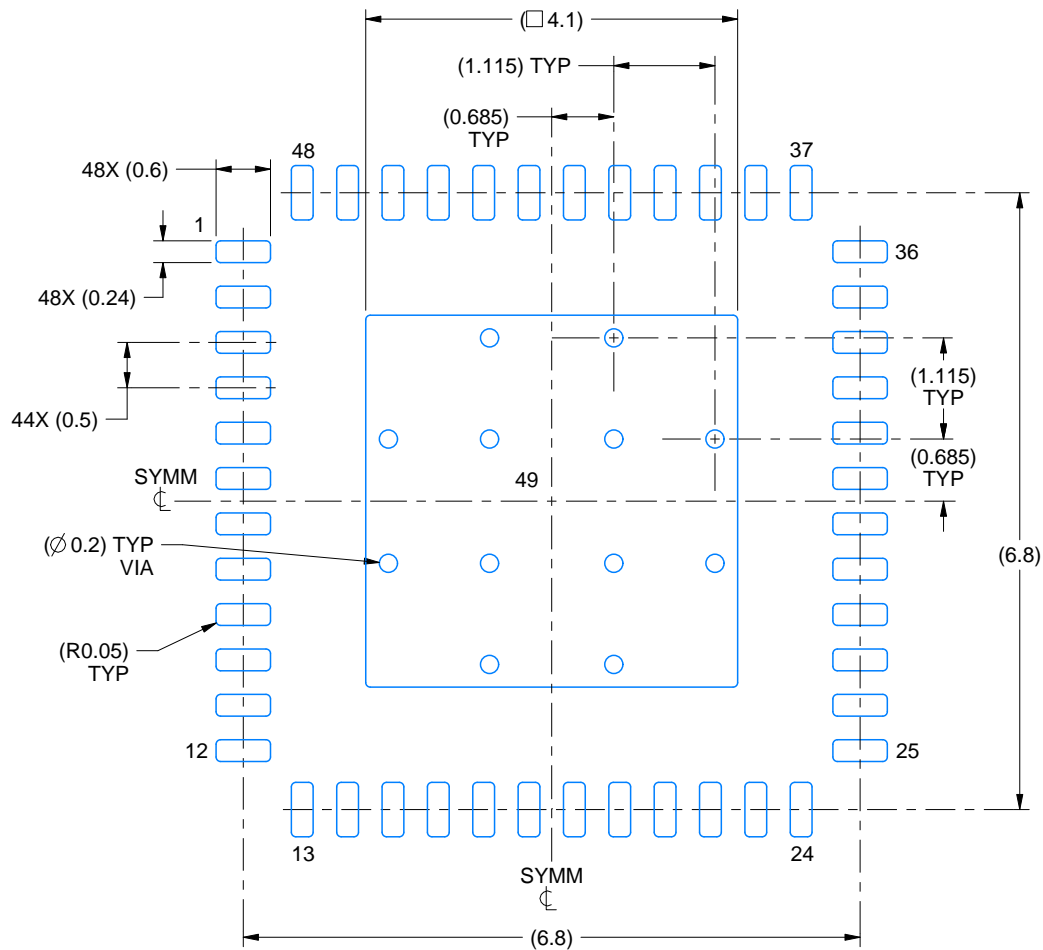

**LAND PATTERN EXAMPLE**  
EXPOSED METAL SHOWN  
SCALE:12X

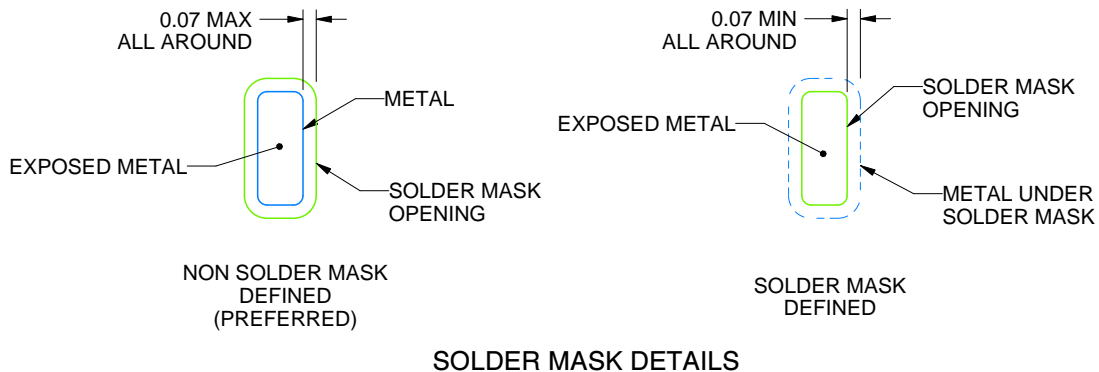

**SOLDER MASK DETAILS**

4218795/B 02/2017

NOTES: (continued)

4. This package is designed to be soldered to a thermal pad on the board. For more information, see Texas Instruments literature number SLUA271 ([www.ti.com/lit/sluea271](http://www.ti.com/lit/sluea271)).
5. Vias are optional depending on application, refer to device data sheet. If any vias are implemented, refer to their locations shown on this view. It is recommended that vias under paste be filled, plugged or tented.

# EXAMPLE STENCIL DESIGN

RGZ0048B

VQFN - 1 mm max height

PLASTIC QUAD FLATPACK - NO LEAD

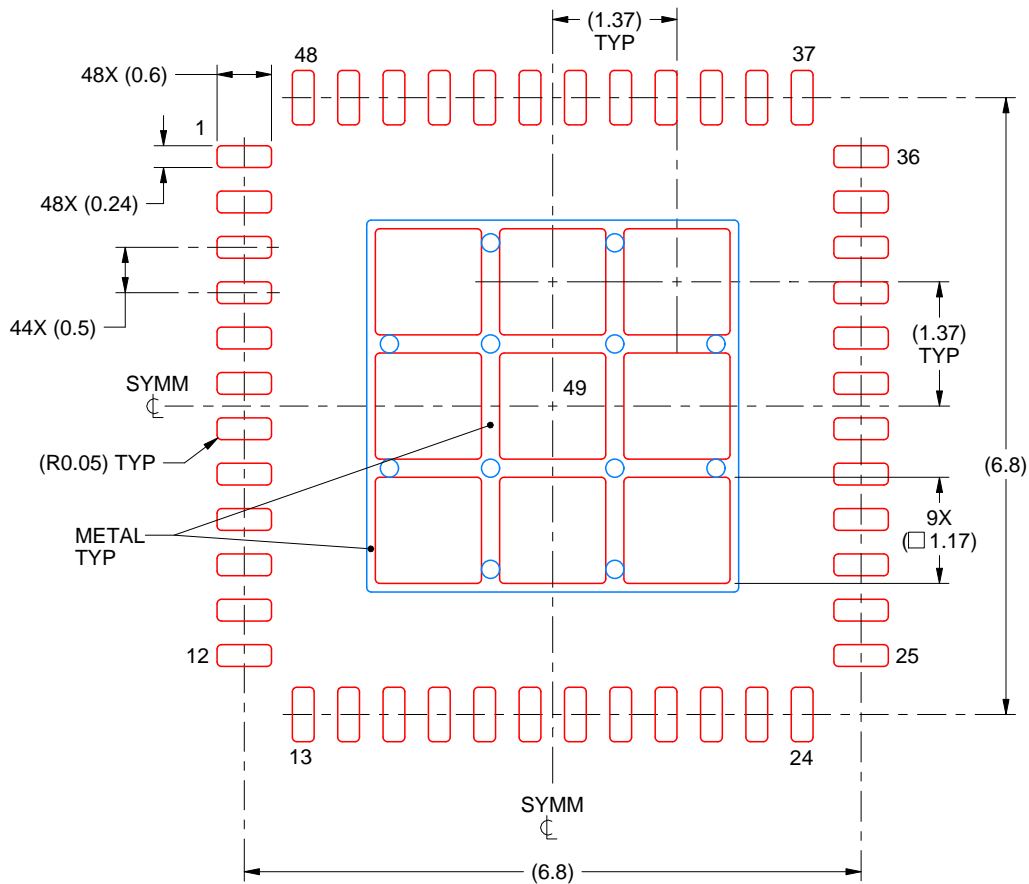

## SOLDER PASTE EXAMPLE BASED ON 0.125 mm THICK STENCIL

EXPOSED PAD 49  
73% PRINTED SOLDER COVERAGE BY AREA UNDER PACKAGE  
SCALE:12X

4218795/B 02/2017

NOTES: (continued)

6. Laser cutting apertures with trapezoidal walls and rounded corners may offer better paste release. IPC-7525 may have alternate design recommendations.

## IMPORTANT NOTICE AND DISCLAIMER

TI PROVIDES TECHNICAL AND RELIABILITY DATA (INCLUDING DATASHEETS), DESIGN RESOURCES (INCLUDING REFERENCE DESIGNS), APPLICATION OR OTHER DESIGN ADVICE, WEB TOOLS, SAFETY INFORMATION, AND OTHER RESOURCES "AS IS" AND WITH ALL FAULTS, AND DISCLAIMS ALL WARRANTIES, EXPRESS AND IMPLIED, INCLUDING WITHOUT LIMITATION ANY IMPLIED WARRANTIES OF MERCHANTABILITY, FITNESS FOR A PARTICULAR PURPOSE OR NON-INFRINGEMENT OF THIRD PARTY INTELLECTUAL PROPERTY RIGHTS.

These resources are intended for skilled developers designing with TI products. You are solely responsible for (1) selecting the appropriate TI products for your application, (2) designing, validating and testing your application, and (3) ensuring your application meets applicable standards, and any other safety, security, or other requirements. These resources are subject to change without notice. TI grants you permission to use these resources only for development of an application that uses the TI products described in the resource. Other reproduction and display of these resources is prohibited. No license is granted to any other TI intellectual property right or to any third party intellectual property right. TI disclaims responsibility for, and you will fully indemnify TI and its representatives against, any claims, damages, costs, losses, and liabilities arising out of your use of these resources.

TI's products are provided subject to TI's Terms of Sale ([www.ti.com/legal/termsofsale.html](http://www.ti.com/legal/termsofsale.html)) or other applicable terms available either on [ti.com](http://ti.com) or provided in conjunction with such TI products. TI's provision of these resources does not expand or otherwise alter TI's applicable warranties or warranty disclaimers for TI products.

Mailing Address: Texas Instruments, Post Office Box 655303, Dallas, Texas 75265  
Copyright © 2018, Texas Instruments Incorporated

## Looking for pricing, stock, or lifecycle information?

Click below to explore more details on WIN SOURCE:

 [View DP83867IRPAPT](#) on WIN SOURCE

 [Texas Instruments](#) Information

## Optimize Your Supply Chain with WIN SOURCE Solutions

-  Global Sourcing Solution
-  Obsolete Management
-  Cost Control Management
-  Shortage Management
-  Alternative Solution
-  Excess Inventory Management