



**THE DATASHEET OF
CD54NP-100MC**



SMD Power Inductor CD54



Description

- Ferrite drum core construction.
- Magnetically unshielded.
- L × W × H: 6.1 × 5.5 × 4.85mm Max.
- Product weight 0.4g(Ref.)
- Moisture Sensitivity Level: 1
- RoHS compliance.

Dimension - [mm]

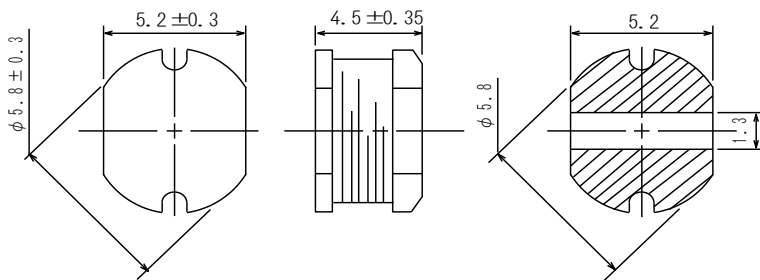

Land pattern and Schematics - [mm]

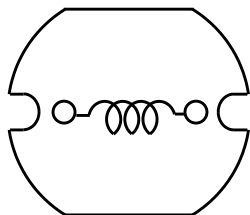
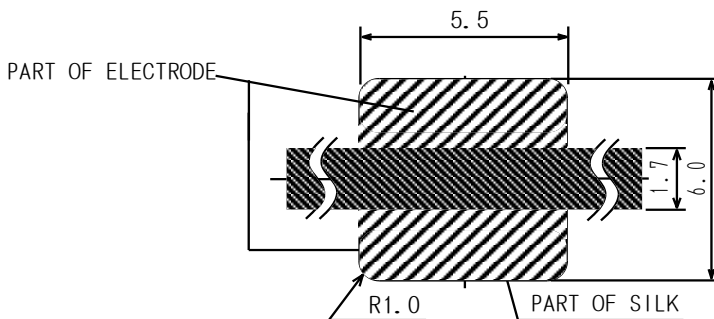

Environmental Data

- Operating temperature range: -40°C ~ +100°C (including coil's self temperature rise)
- Storage temperature range: -40°C ~ +100°C
- Solder reflow temperature: 260 °C peak.

Packaging

- Carrier tape and reel packaging.
- 13.0" diameter reel
- 1500pcs per reel

Applications

- Ideally used in Mobilephone, PDA, MP3, DSC/DVC, portable DVD etc as DC-DC Converter inductors.



Electrical Characteristics

| Part Name | Stamp | Inductance (μH) [within] ※1 | D.C.R (Ω) [Max.] (at 20°C) | Rated Current (A) ※2 |
|--------------|-------|--|--|-------------------------|
| CD54NP-100MC | 100 | 10 \pm 20% | 0.10 | 1.44 |
| CD54NP-120MC | 120 | 12 \pm 20% | 0.12 | 1.40 |
| CD54NP-150MC | 150 | 15 \pm 20% | 0.14 | 1.30 |
| CD54NP-180MC | 180 | 18 \pm 20% | 0.15 | 1.23 |
| CD54NP-220MC | 220 | 22 \pm 20% | 0.18 | 1.11 |
| CD54NP-270MC | 270 | 27 \pm 20% | 0.20 | 0.97 |
| CD54NP-330LC | 330 | 33 \pm 15% | 0.23 | 0.88 |
| CD54NP-390LC | 390 | 39 \pm 15% | 0.32 | 0.80 |
| CD54NP-470LC | 470 | 47 \pm 15% | 0.37 | 0.72 |
| CD54NP-560KC | 560 | 56 \pm 10% | 0.42 | 0.68 |
| CD54NP-680KC | 680 | 68 \pm 10% | 0.46 | 0.61 |
| CD54NP-820KC | 820 | 82 \pm 10% | 0.60 | 0.58 |
| CD54NP-101KC | 101 | 100 \pm 10% | 0.70 | 0.52 |
| CD54NP-121KC | 121 | 120 \pm 10% | 0.93 | 0.48 |
| CD54NP-151KC | 151 | 150 \pm 10% | 1.10 | 0.40 |
| CD54NP-181KC | 181 | 180 \pm 10% | 1.38 | 0.38 |
| CD54NP-221KC | 221 | 220 \pm 10% | 1.57 | 0.35 |

※1: Inductance measuring frequency: 10 μH ~ 82 μH , at 2.52MHz.
100 μH ~ 220 μH , at 1 kHz.

※2: Rated current: The DC current at which the inductance decreases to 90 % of it's initial value or when $\Delta t=40^\circ\text{C}$, whichever is lower ($T_a=20^\circ\text{C}$).

SMD Power Inductor CD54



Saturation Current & Temperature Rise Graph

— L (20°C) — L (105°C) — ΔT

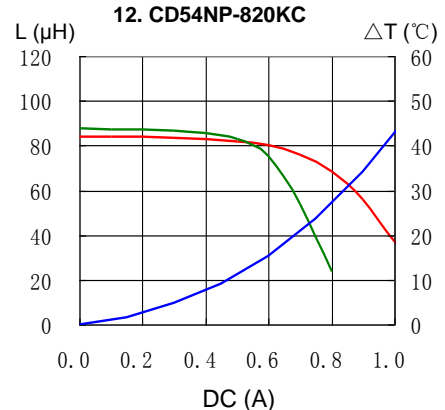
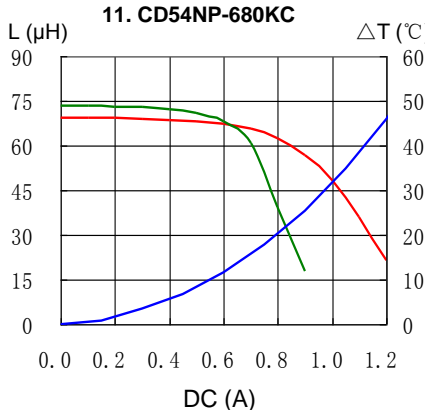
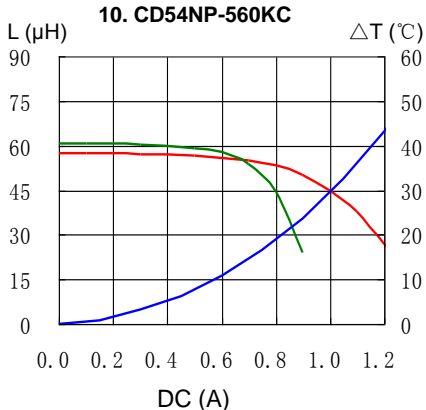
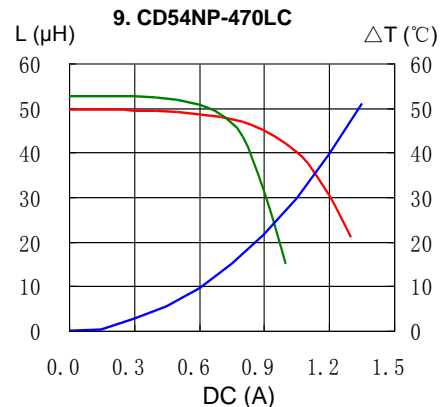
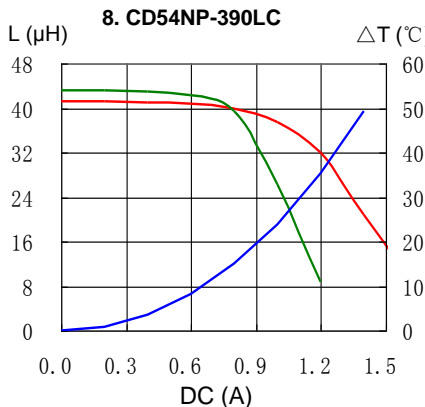
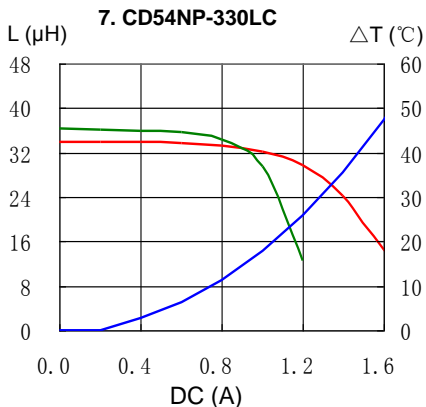
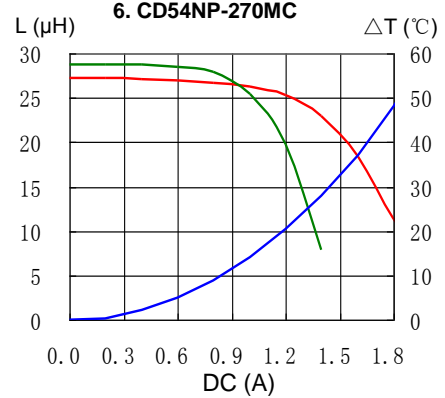
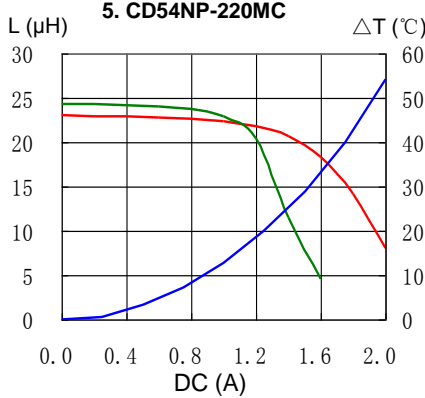
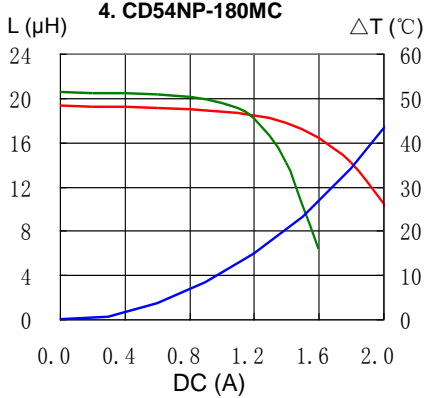
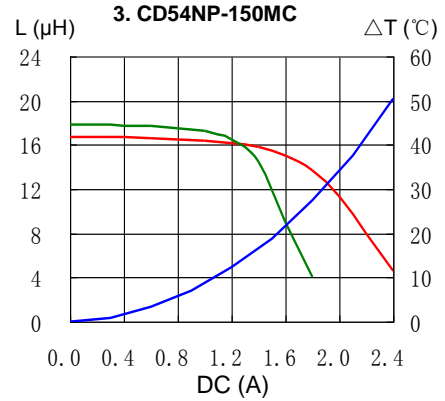
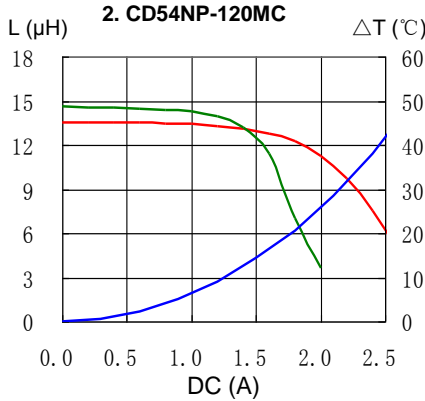
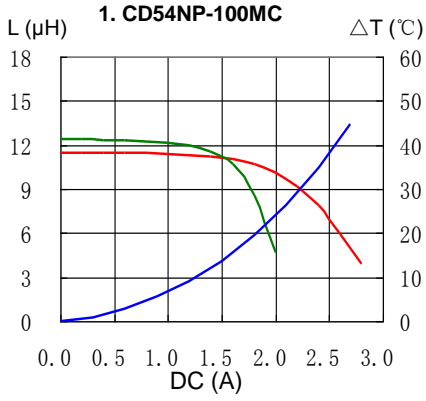

SMD Power Inductor CD54



Saturation Current & Temperature Rise Graph

— L (20°C) — L (105°C) — ΔT

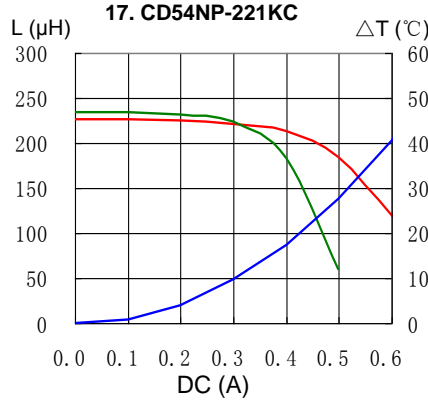
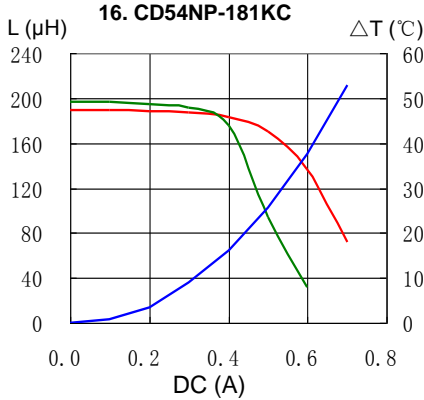
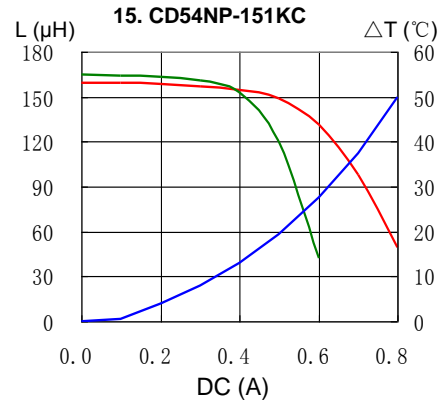
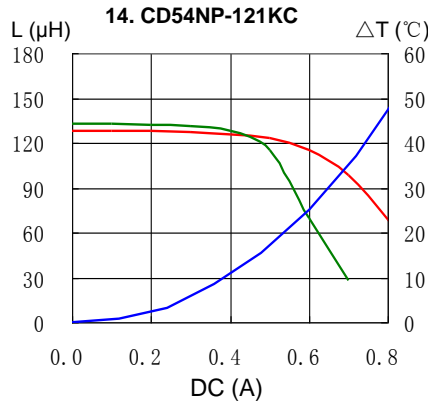
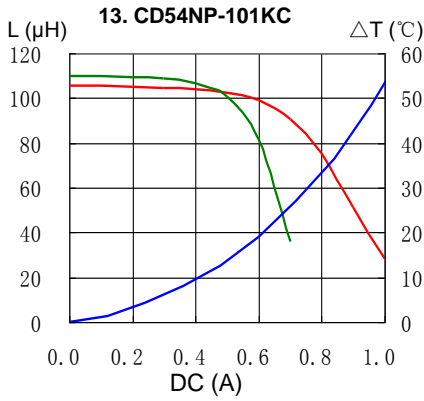

Solder Reflow Condition

Heat Endurance

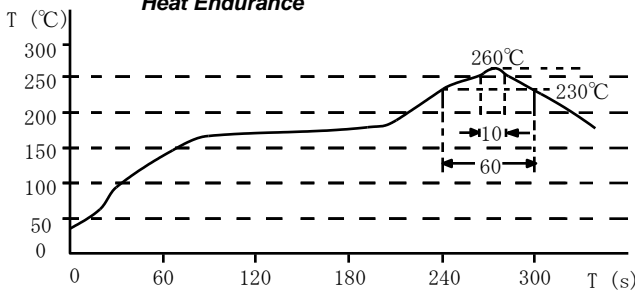

Temperature Chart

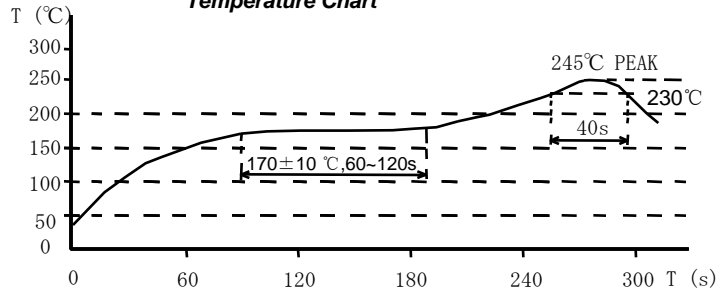

Please refer to the sales offices on our website - <http://www.sumida.com>

Hong Kong

Tel.+852-2880-6781
FAX.+852-2565-9600
sales@hk.sumida.com

Saitama(Japan)

Tel.+81-48-691-7300
FAX.+81-48-691-7340
sales@jp.sumida.com

Chicago

Tel.+1-847-545-6700
FAX. +1-847-545-6720
sales@us.sumida.com

Shanghai

Tel.+86-21-5836-3299
FAX.+86-21-5836-3266
shanghai.sales@cn.sumida.com

Seoul

Tel.+82-2-6237-0777
FAX.+82-2-6237-0778
sales@kr.sumida.com

Obernzell

Tel.+49-8591-937-0
FAX. +49-8591-937-103
contact@eu.sumida.com

Shenzhen

Tel.+86-755-8291-0228
FAX.+86-755-8291-0338
shenzhen.sales@cn.sumida.com

Singapore

Tel.+65-6296-3388
FAX.+65-6841-4426
sales@sg.sumida.com

Neumarkt

Tel.+49-9181-4509-110
FAX. +49-9181-4509-310
infocomp@eu.sumida.com

Taipei



Tel.+886-2-8751-2737
FAX.+886-2-8751-2738
sales@tw.sumida.com

San Jose







Tel.+1-408-321-9660
FAX.+1-408-321-9308
sales@us.sumida.com

Looking for pricing, stock, or lifecycle information?

Click below to explore more details on WIN SOURCE:

-  [View CD54NP-100MC on WIN SOURCE](#)
-  [Sumida America Components Inc. Information](#)

Optimize Your Supply Chain with WIN SOURCE Solutions

-  Global Sourcing Solution
-  Obsolete Management
-  Cost Control Management
-  Shortage Management
-  Alternative Solution
-  Excess Inventory Management