



THE DATASHEET OF CAT803RTBI-GT3



CAT803, CAT809, CAT810

3-Pin Microprocessor Power Supply Supervisors

Description

The CAT803, CAT809, and CAT810 are supervisory circuits that monitor power supplies in digital systems. The CAT803, CAT809, and CAT810 are direct replacements for the MAX803, MAX809 and MAX810 in applications operating over the industrial temperature range.

These devices generate a reset signal, which is asserted while the power supply voltage is below a preset threshold level and for at least 140 ms after the power supply level has risen above that level. The underlying floating gate technology, Analog EEPROM used by ON Semiconductor, makes it possible to offer any custom reset threshold value. Seven industry standard threshold levels are offered to support +5.0 V, +3.3 V, +3.0 V and +2.5 V systems.

The CAT803 has an open-drain $\overline{\text{RESET}}$ output (active LOW). The CAT803 requires a pull-up resistor on the reset output.

The CAT809 features a push-pull $\overline{\text{RESET}}$ output (active LOW) and the CAT810 features a push-pull RESET output (active HIGH).

Fast transients on the power supply are ignored and the output is guaranteed to be in the correct state at V_{CC} levels as low as 1.0 V.

The CAT803, CAT809, and CAT810 are available in both the compact 3-pin SOT-23 and SC-70 packages.

Features

- Precision Monitoring of
 - +5.0 V (–5%, –10%, –20%),
 - +3.3 V (–5%, –10%),
 - +3.0 V (–10%) and
 - +2.5 V (–5%) Power Supplies
- Offered in Three Output Configurations:
 - CAT803: Open-Drain Active LOW Reset
 - CAT809: Push-Pull Active LOW Reset
 - CAT810: Push-Pull Active HIGH Reset
- Direct Replacements for the MAX803, MAX809 and MAX810 in Applications Operating over the Industrial Temperature Range
- Reset Valid down to $V_{CC} = 1.0$ V
- 6 μA Power Supply Current
- Power Supply Transient Immunity
- Industrial Temperature Range: -40°C to $+85^{\circ}\text{C}$
- Available in SOT-23 and SC-70 Packages
- These Devices are Pb-Free and are RoHS Compliant

Applications

- Computers, Servers, Laptops, Cable Modems
- Wireless Communications
- Embedded Control Systems
- White Goods, Power Meters
- Intelligent Instruments
- PDAs and Handheld Equipment



ON Semiconductor®

<http://onsemi.com>



SOT-23
TB SUFFIX
CASE 527AG



SC-70
SD SUFFIX
CASE 419AB

PIN CONFIGURATION

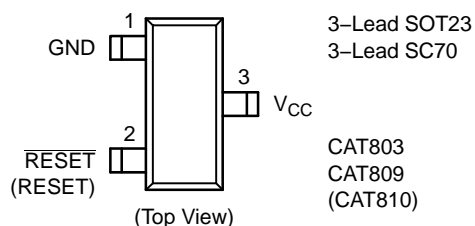

MARKING DIAGRAMS

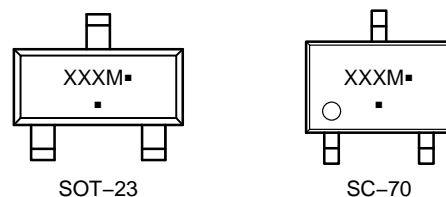

XXX = Specific Device Code
M = Month Code
▪ = Pb-Free Package

(*Note: Microdot may be in either location)

ORDERING INFORMATION

See detailed ordering and shipping information in the package dimensions section on page 8 of this data sheet.

CAT803, CAT809, CAT810

Table 1. THRESHOLD SUFFIX SELECTOR

Nominal Threshold Voltage	Threshold Suffix Designation
4.63 V	L
4.55 V	H
4.38 V	M
4.00 V	J
3.08 V	T
2.93 V	S
2.63 V	R
2.32 V	Z
1.60 V	V

Table 2. PIN DESCRIPTIONS

Pin Number			Name	Description
CAT803	CAT809	CAT810		
1	1	1	GND	Ground
2	2	–	RESET	Active LOW reset. RESET is asserted if V_{CC} falls below the reset threshold and remains low for at least 140 ms after V_{CC} rises above the reset threshold.
–	–	2	RESET	Active HIGH reset. RESET is asserted if V_{CC} falls below the reset threshold and remains high for at least 140 ms after V_{CC} rises above the reset threshold.
3	3	3	V_{CC}	Power supply voltage that is monitored.

Table 3. ABSOLUTE MAXIMUM RATINGS

Parameter	Rating	Units
Any pin with respect to ground	–0.3 to +6.0	V
Input Current, V_{CC}	20	mA
Output Current, RESET, $\overline{\text{RESET}}$	20	mA
Rate of Rise, V_{CC}	100	V/ μ s
Continuous Power Dissipation Derate 2.2 mW/ $^{\circ}$ C above 70 $^{\circ}$ C (SC70) Derate 4 mW/ $^{\circ}$ C above 70 $^{\circ}$ C (SOT23)	175 320	mW
Operating Temperature Range	–40 to +85	$^{\circ}$ C
Storage Temperature Range	–65 to +105	$^{\circ}$ C
Lead Soldering Temperature (10 sec)	300	$^{\circ}$ C

Stresses exceeding those listed in the Maximum Ratings table may damage the device. If any of these limits are exceeded, device functionality should not be assumed, damage may occur and reliability may be affected.

CAT803, CAT809, CAT810

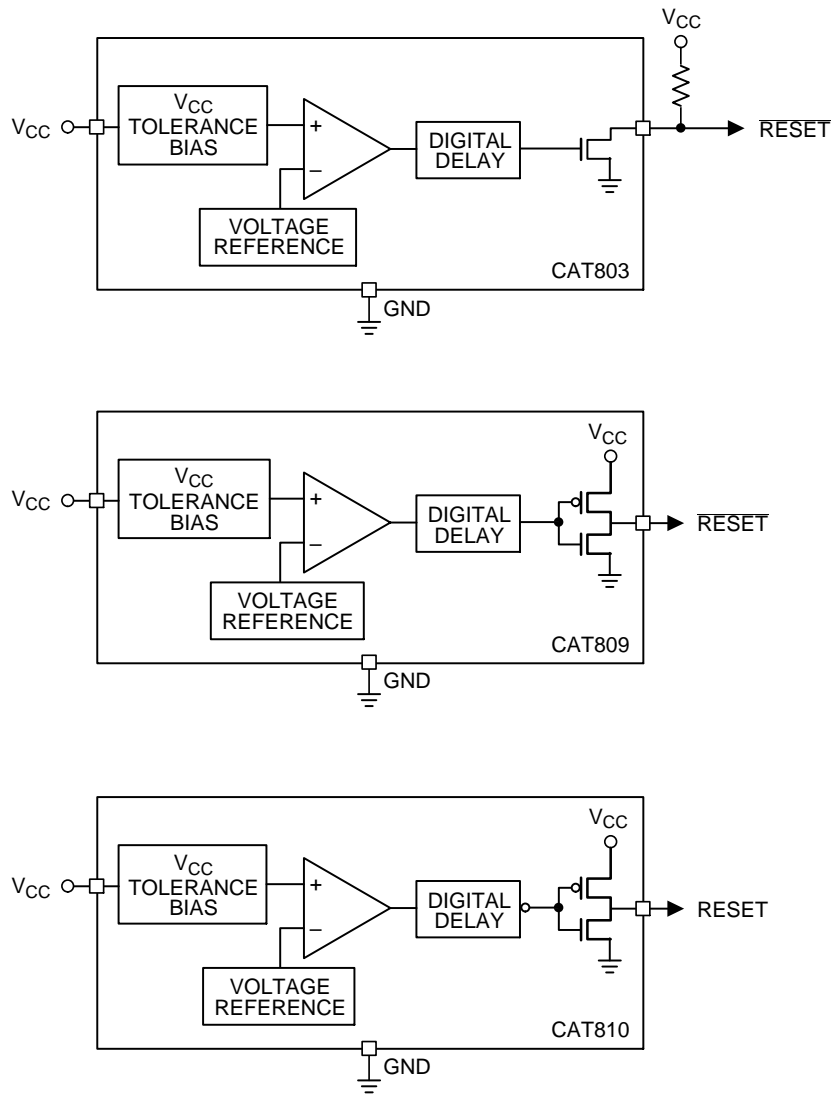

Figure 1. Block Diagrams

CAT803, CAT809, CAT810

Table 4. ELECTRICAL CHARACTERISTICS

(V_{CC} = Full range, T_A = -40°C to $+85^{\circ}\text{C}$, unless otherwise specified. Typical values at T_A = $+25^{\circ}\text{C}$ and V_{CC} = 5 V for the L/H/M/J versions, V_{CC} = 3.3 V for the T/S versions, V_{CC} = 3 V for the R version and V_{CC} = 2.5 V for the Z/V versions.)

Symbol	Parameter	Conditions	Min	Typ (Note 1)	Max	Units			
	V_{CC} Range	T_A = 0°C to $+70^{\circ}\text{C}$	1.0		5.5	V			
		T_A = -40°C to $+85^{\circ}\text{C}$	1.2		5.5				
I_{CC}	Supply Current	T_A = -40°C to $+85^{\circ}\text{C}$	V_{CC} < 5.5 V, J/L/M/H	8	20	μA			
			V_{CC} < 3.6 V, R/S/T/Z/V	6	15				
V_{TH}	Reset Threshold Voltage	L Threshold	T_A = $+25^{\circ}\text{C}$	4.56	4.63	4.70	V		
			T_A = -40°C to $+85^{\circ}\text{C}$	4.50		4.75			
		H Threshold	T_A = $+25^{\circ}\text{C}$	4.48	4.55	4.62			
			T_A = -40°C to $+85^{\circ}\text{C}$	4.43		4.67			
		M Threshold	T_A = $+25^{\circ}\text{C}$	4.31	4.38	4.45			
			T_A = -40°C to $+85^{\circ}\text{C}$	4.25		4.50			
		J Threshold	T_A = $+25^{\circ}\text{C}$	3.93	4.00	4.06			
			T_A = -40°C to $+85^{\circ}\text{C}$	3.89		4.10			
		T Threshold	T_A = $+25^{\circ}\text{C}$	3.04	3.08	3.11			
			T_A = -40°C to $+85^{\circ}\text{C}$	3.00		3.15			
		S Threshold	T_A = $+25^{\circ}\text{C}$	2.89	2.93	2.96			
			T_A = -40°C to $+85^{\circ}\text{C}$	2.85		3.00			
		R Threshold	T_A = $+25^{\circ}\text{C}$	2.59	2.63	2.66			
			T_A = -40°C to $+85^{\circ}\text{C}$	2.55		2.70			
		Z Threshold	T_A = $+25^{\circ}\text{C}$	2.28	2.32	2.35			
			T_A = -40°C to $+85^{\circ}\text{C}$	2.25		2.38			
		V Threshold	T_A = $+25^{\circ}\text{C}$	1.58	1.60	1.62			
			T_A = -40°C to $+85^{\circ}\text{C}$	1.56		1.64			
			Reset Threshold Tempco			30			ppm/ $^{\circ}\text{C}$
		T_D	V_{CC} to Reset Delay (Note 2)	$V_{CC} = V_{TH}$ to $(V_{TH} - 100\text{ mV})$		20			μs
T_R	Reset Active Timeout Period	T_A = -40°C to $+85^{\circ}\text{C}$	140	240	460	ms			
V_{OL}	RESE \bar{T} Output Voltage Low (Open-drain active LOW, CAT803 and push-pull, active LOW, CAT809)	$V_{CC} = V_{TH}$ min, $I_{SINK} = 1.2\text{ mA}$ CAT803R/S/T/Z, CAT809R/S/T/Z/V			0.3	V			
		$V_{CC} = V_{TH}$ min, $I_{SINK} = 3.2\text{ mA}$ CAT803J/L/M, CAT809J/L/M/H			0.4				
		$V_{CC} > 1.0\text{ V}$, $I_{SINK} = 50\ \mu\text{A}$			0.3				
V_{OH}	RESE \bar{T} Output Voltage High (Push-pull, active LOW, CAT809)	$V_{CC} = V_{TH}$ max, $I_{SOURCE} = 500\ \mu\text{A}$ CAT809R/S/T/Z/V	$0.8 V_{CC}$			V			
		$V_{CC} = V_{TH}$ max, $I_{SOURCE} = 800\ \mu\text{A}$ CAT809J/L/M/H	$V_{CC} - 1.5$						
V_{OL}	RESE \bar{T} Output Voltage Low (Push-pull, active HIGH, CAT810)	$V_{CC} > V_{TH}$ max, $I_{SINK} = 1.2\text{ mA}$ CAT810R/S/T/Z			0.3	V			
		$V_{CC} > V_{TH}$ max, $I_{SINK} = 3.2\text{ mA}$ CAT810J/L/M			0.4				
V_{OH}	RESE \bar{T} Output Voltage High (Push-pull, active HIGH, CAT810)	$1.8\text{ V} < V_{CC}$, V_{TH} min, $I_{SOURCE} = 150\ \mu\text{A}$	$0.8 V_{CC}$			V			

1. Production testing done at T_A = $+25^{\circ}\text{C}$; limits over temperature guaranteed by design only.
2. RESE \bar{T} output for the CAT809; RESE \bar{T} output for the CAT810.

CAT803, CAT809, CAT810

TYPICAL OPERATING CHARACTERISTICS

(V_{CC} = Full range, T_A = -40°C to $+85^{\circ}\text{C}$, unless otherwise specified. Typical values at T_A = $+25^{\circ}\text{C}$ and V_{CC} = 5 V for the L/M/J versions, V_{CC} = 3.3 V for the T/S versions, V_{CC} = 3 V for the R version and V_{CC} = 2.5 V for the Z version.)

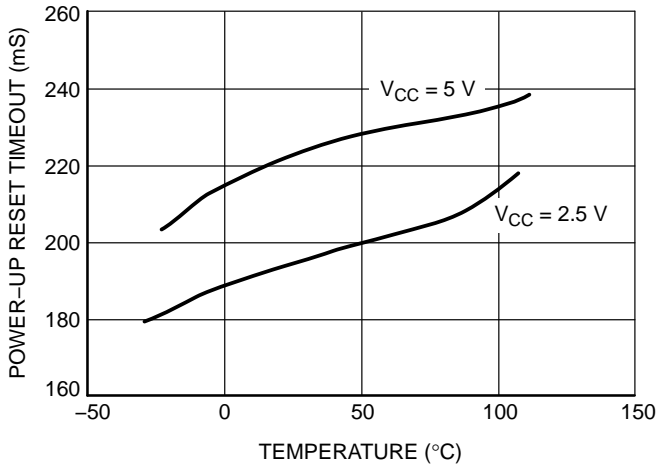

Figure 2. Power-up Reset Timeout vs. Temperature

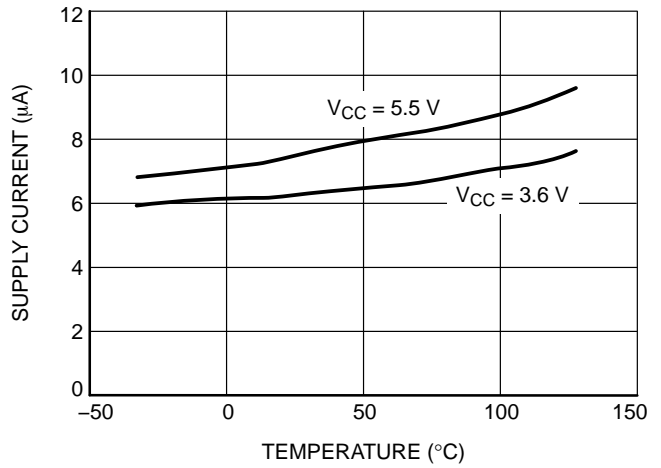

Figure 3. Supply Current vs. Temperature (No Load, CAT8xxR/S/T/Z)

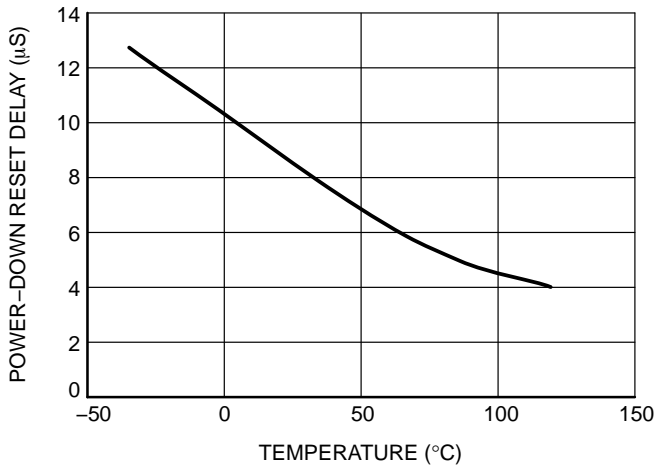

Figure 4. Power-down Reset Delay vs. Temperature (CAT8xxR/S/T/Z)

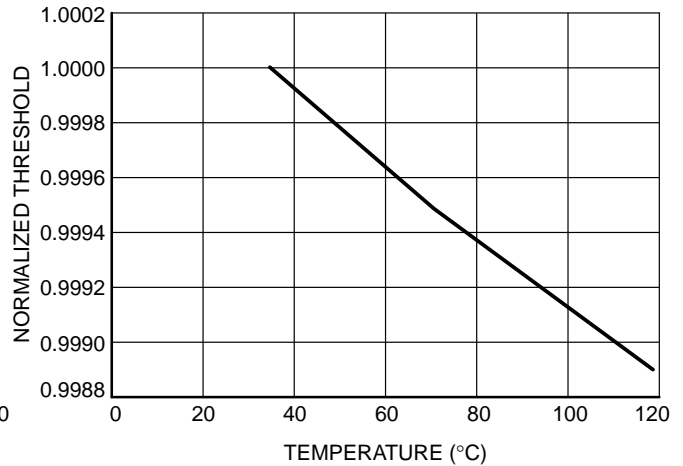

Figure 5. Normalized Reset Threshold vs. Temperature

CAT803, CAT809, CAT810

Detailed Descriptions

Reset Timing

The reset signal is asserted LOW for the CAT803/CAT809 and HIGH for the CAT810 when the power supply voltage falls below the threshold trip voltage and remains asserted for at least 140 ms after the power supply voltage has risen above the threshold.

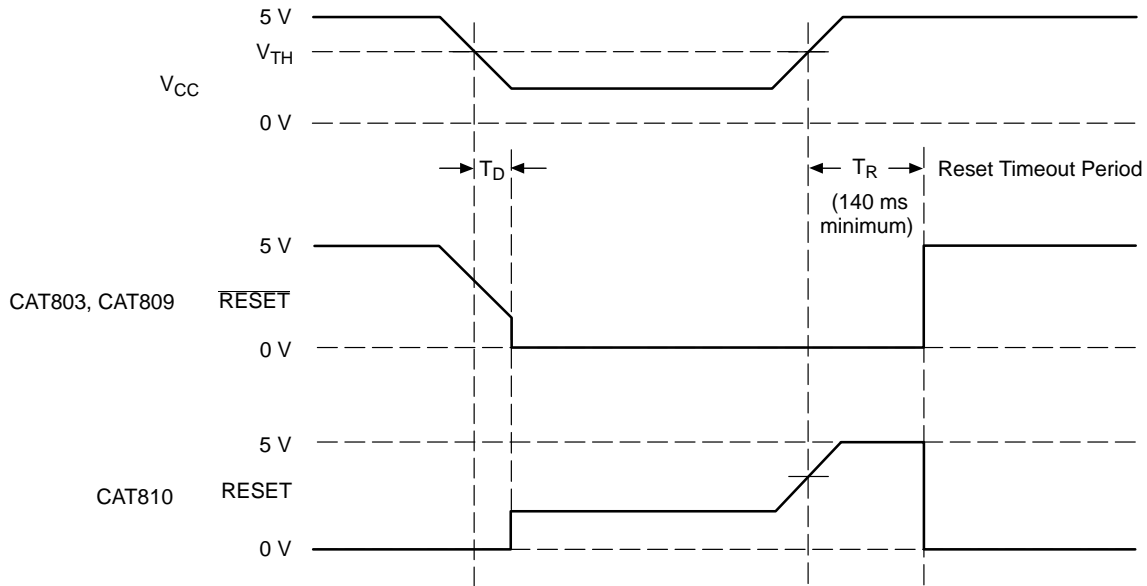

Figure 6. Reset Timing Diagram

V_{CC} Transient Response

The CAT803/CAT809/CAT810 protect μ Ps against brownout failure. Short duration transients of 4 μ sec or less and 100 mV amplitude typically do not cause a false RESET.

Figure 7 shows the maximum pulse duration of negative-going V_{CC} transients that do not cause a reset condition.

As the amplitude of the transient goes further below the threshold (increasing $V_{TH} - V_{CC}$), the maximum pulse duration decreases. In this test, the V_{CC} starts from an initial voltage of 0.5 V above the threshold and drops below it by the amplitude of the overdrive voltage ($V_{TH} - V_{CC}$).

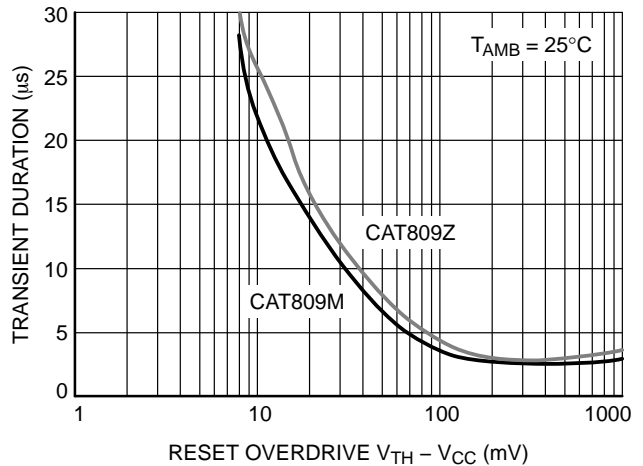

Figure 7. Maximum Transient Duration without Causing a Reset Pulse vs. Reset Comparator Overdrive

CAT803, CAT809, CAT810

Valid RESET with V_{CC} Under 1.0 V

To ensure that the CAT809 RESET pin is in a known state when V_{CC} is under 1.0 V, a $>10\text{ k}\Omega$ pull-down resistor between RESET pin and GND is recommended. For the CAT810, a pull-up resistor from RESET pin to V_{CC} is needed.

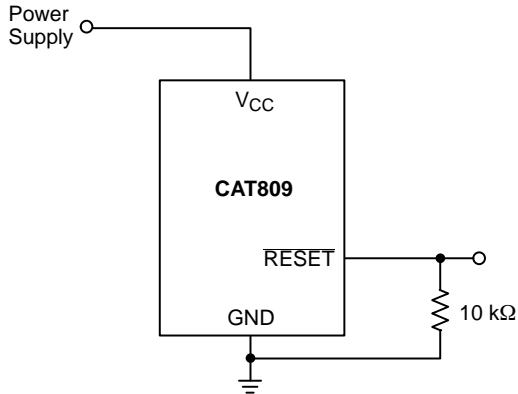

Figure 8. RESET Valid with V_{CC} Under 1.0 V

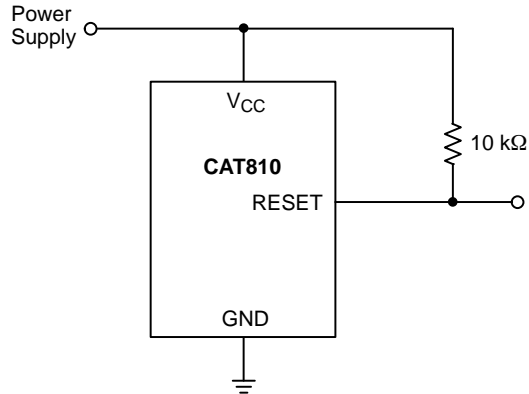

Figure 9. RESET Valid with V_{CC} Under 1.1 V

Bi-directional Reset Pin Interfacing

The CAT809/810 can interface with $\mu\text{P}/\mu\text{C}$ bi-directional reset pins by connecting a $4.7\text{ k}\Omega$ resistor in series with the CAT809/810 reset output and the $\mu\text{P}/\mu\text{C}$ bi-directional reset pin.

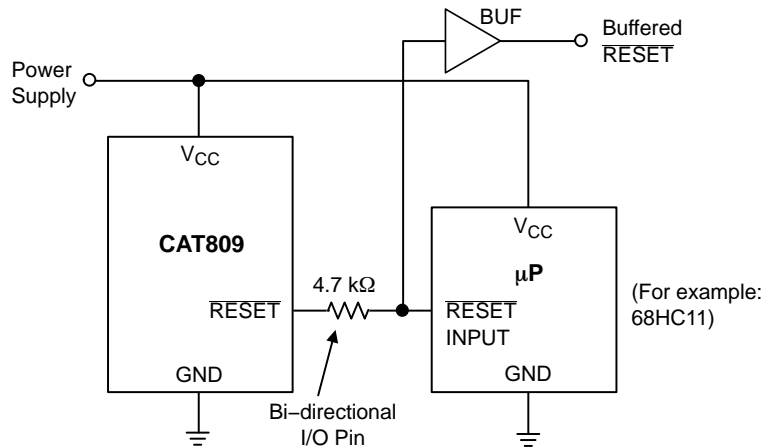

Figure 10. Bi-directional Reset Pin Interfacing

CAT803 Open-Drain RESET Application

The CAT803 features an open-drain RESET output and therefore needs a pull-up resistor on the output for proper operation, as shown on Figure 11. An advantage of the open-drain output includes the ability to “wire AND” several outputs together to form an inexpensive logic circuit. It is also possible to have the pull-up resistor connected to a different supply which can be higher than the CAT803 V_{CC} pin. The value of the pull-up resistor is not critical in most applications, typical values being between $5\text{ k}\Omega$ and $10\text{ k}\Omega$.

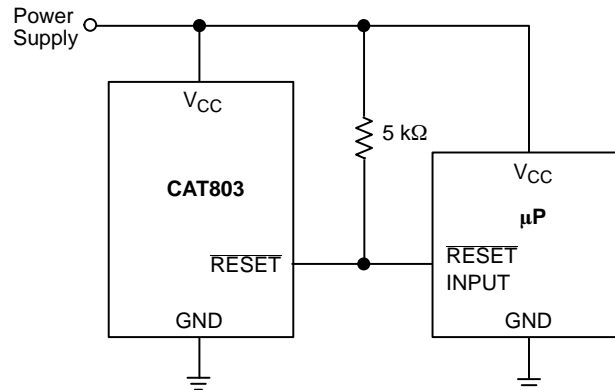

Figure 11. Typical CAT803 Open-Drain Circuit Configuration

CAT803, CAT809, CAT810

Table 5. ORDERING PART NUMBER

Order Number		Voltage	Top Mark (Note 3)		Output	Reset	Package	Quantity per Reel (Note 4)
NiPdAu	Matte-Tin		NiPdAu	Matte-Tin				
CAT803LSDI-GT3*		4.63 V	VKA	VKL	Open Drain	LOW	SC70-3	3,000
CAT803MSDI-GT3*		4.38 V	VKA	VKL				
CAT803JSDI-GT3*		4.00 V	VKA	VKL				
CAT803TSDI-GT3*	CAT803TSDI-T3*	3.08 V	VKA	VKL				
CAT803SSDI-GT3	CAT803SSDI-T3*	2.93 V	VKA	VKL				
CAT803RSDI-GT3*		2.63 V	VKA	VKL				
CAT803ZSDI-GT3*		2.32 V	VKA	VKL				
CAT803LTBI-GT3*		4.63 V	VKA	VKL	Open Drain	LOW	SOT-23-3	
CAT803MTBI-GT3*	CAT803MTBI-T3*	4.38 V	VKA	VKL				
CAT803JTBI-GT3*		4.00 V	VKA	VKL				
CAT803TTBI-GT3*	CAT803TTBI-T3*	3.08 V	VKA	VKL				
CAT803STBI-GT3*	CAT803STBI-T3*	2.93 V	VKA	VKL				
CAT803RTBI-GT3*	CAT803RTBI-T3*	2.63 V	VKA	VKL				
CAT803ZTBI-GT3*		2.32 V	VKA	VKL				
CAT809LSDI-GT3*		4.63 V	VLA	VLD	CMOS / Push-Pull	LOW	SC70-3	
CAT809MSDI-GT3*		4.38 V	VLA	VLD				
CAT809JSDI-GT3*		4.00 V	VLA	VLD				
CAT809TSDI-GT3*	CAT809TSDI-T3*	3.08 V	VLA	VLD				
CAT809SSDI-GT3*	CAT809SSDI-T3*	2.93 V	VLA	VLD				
CAT809RSDI-GT3*		2.63 V	VLA	VLD				
CAT809ZSDI-GT3*	CAT809ZSDI-T3*	2.32 V	VLA	VLD				
CAT809LTBI-GT3	CAT809LTBI-T3*	4.63 V	VLA	VLD	CMOS / Push-Pull	LOW	SOT-23-3	
CAT809HTBI-GT3*	CAT809HTBI-T3*	4.55 V	VLA	VLD				
CAT809MTBI-GT3	CAT809MTBI-T3*	4.38 V	VLA	VLD				
CAT809JTBI-GT3	CAT809JTBI-T3*	4.00 V	VLA	VLD				
CAT809TTBI-GT3	CAT809TTBI-T3*	3.08 V	VLA	VLD				
CAT809STBI-GT3	CAT809STBI-T3*	2.93 V	VLA	VLD				
CAT809RTBI-GT3	CAT809RTBI-T3*	2.63 V	VLA	VLD				
CAT809ZTBI-GT3	CAT809ZTBI-T3*	2.32 V	VLA	VLD				
CAT809VTBI-GT3		1.60 V	VLA	VLD				

3. Threshold and full part numbers will be provided on box and reel labels as well as all Shipping documents.
4. For information on tape and reel specifications, including part orientation and tape sizes, please refer to our Tape and Reel Packaging Specifications Brochure, BRD8011/D.
5. For detailed information and a breakdown of device nomenclature and numbering systems, please see the ON Semiconductor Device Nomenclature document, TND310/D, available at www.onsemi.com

*These devices are beginning End Of Life proceedings.

CAT803, CAT809, CAT810

Table 5. ORDERING PART NUMBER

Order Number		Voltage	Top Mark (Note 3)		Output	Reset	Package	Quantity per Reel (Note 4)
NiPdAu	Matte-Tin		NiPdAu	Matte-Tin				
CAT810LSDI-GT3*		4.63 V	VHA	VHT	CMOS / Push-Pull	HIGH	SC70-3	3,000
CAT810MSDI-GT3*		4.38 V	VHA	VHT				
CAT810JSDI-GT3*		4.00 V	VHA	VHT				
CAT810TSDI-GT3*		3.08 V	VHA	VHT				
CAT810SSDI-GT3*		2.93 V	VHA	VHT				
CAT810RSDI-GT3*		2.63 V	VHA	VHT				
CAT810ZSDI-GT3*		2.32 V	VHA	VHT				
CAT810LTBI-GT3*	CAT810LTBI-T3*	4.63 V	VHA	VHT	CMOS / Push-Pull	HIGH	SOT-23-3	
CAT810MTBI-GT3*	CAT810MTBI-T3*	4.38 V	VHA	VHT				
CAT810JTBI-GT3	CAT810JTBI-T3*	4.00 V	VHA	VHT				
CAT810TTBI-GT3	CAT810TTBI-T3*	3.08 V	VHA	VHT				
CAT810STBI-GT3*	CAT810STBI-T3*	2.93 V	VHA	VHT				
CAT810RTBI-GT3*	CAT810RTBI-T3*	2.63 V	VHA	VHT				
CAT810ZTBI-GT3*	CAT810ZTBI-T3*	2.32 V	VHA	VHT				

3. Threshold and full part numbers will be provided on box and reel labels as well as all Shipping documents.

4. For information on tape and reel specifications, including part orientation and tape sizes, please refer to our Tape and Reel Packaging Specifications Brochure, BRD8011/D.

5. For detailed information and a breakdown of device nomenclature and numbering systems, please see the ON Semiconductor Device Nomenclature document, TND310/D, available at www.onsemi.com

*These devices are beginning End Of Life proceedings.

CAT803, CAT809, CAT810

PACKAGE DIMENSIONS

SOT-23, 3 Lead
CASE 527AG-01
ISSUE O

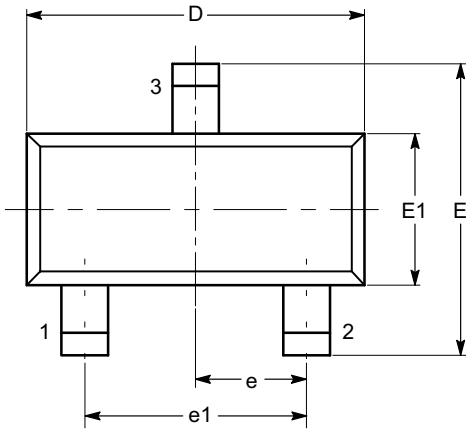

TOP VIEW

SYMBOL	MIN	NOM	MAX
A	0.89		1.12
A1	0.013		0.10
b	0.37		0.50
c	0.085		0.18
D	2.80		3.04
E	2.10		2.64
E1	1.20		1.40
e	0.95 BSC		
e1	1.90 BSC		
L	0.40 REF		
L1	0.54 REF		
θ	0°		8°

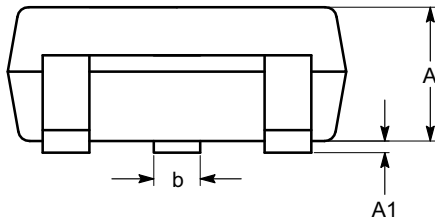

SIDE VIEW

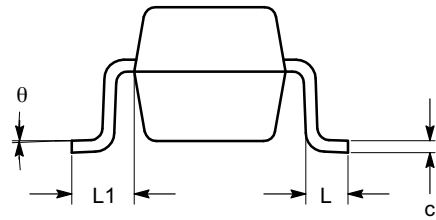

END VIEW

Notes:

- (1) All dimensions are in millimeters. Angles in degrees.
- (2) Complies with JEDEC TO-236.

CAT803, CAT809, CAT810

PACKAGE DIMENSIONS

SC-70, 3 Lead, 1.25x2
CASE 419AB-01
ISSUE O

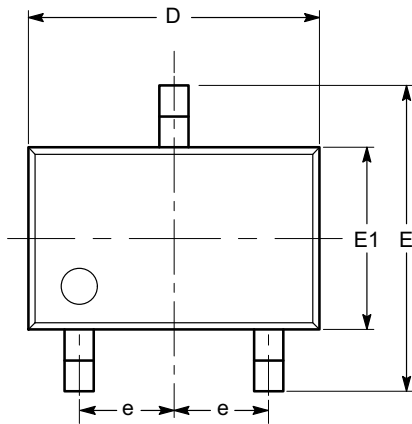

TOP VIEW

SYMBOL	MIN	NOM	MAX
A	0.80		1.10
A1	0.00		0.10
A2	0.80	0.90	1.00
b	0.15		0.30
c	0.08		0.22
D	1.80	2.00	2.20
E	1.80	2.10	2.40
E1	1.15	1.25	1.35
e	0.65 BSC		
L	0.26	0.36	0.46
L1	0.42 REF		
L2	0.15 BSC		
θ	0°		8°
$\theta 1$	4°		10°

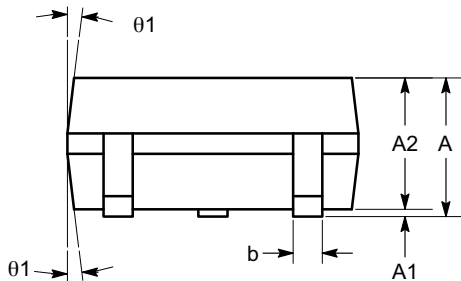

SIDE VIEW

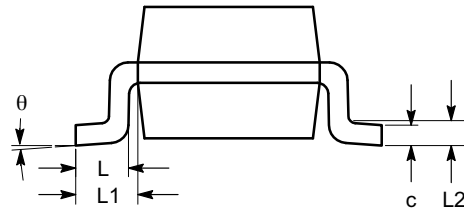

END VIEW

Notes:

- (1) All dimensions are in millimeters. Angles in degrees.
- (2) Complies with JEDEC MO-203.

ON Semiconductor and  are registered trademarks of Semiconductor Components Industries, LLC (SCILLC). SCILLC reserves the right to make changes without further notice to any products herein. SCILLC makes no warranty, representation or guarantee regarding the suitability of its products for any particular purpose, nor does SCILLC assume any liability arising out of the application or use of any product or circuit, and specifically disclaims any and all liability, including without limitation special, consequential or incidental damages. "Typical" parameters which may be provided in SCILLC data sheets and/or specifications can and do vary in different applications and actual performance may vary over time. All operating parameters, including "Typicals" must be validated for each customer application by customer's technical experts. SCILLC does not convey any license under its patent rights nor the rights of others. SCILLC products are not designed, intended, or authorized for use as components in systems intended for surgical implant into the body, or other applications intended to support or sustain life, or for any other application in which the failure of the SCILLC product could create a situation where personal injury or death may occur. Should Buyer purchase or use SCILLC products for any such unintended or unauthorized application, Buyer shall indemnify and hold SCILLC and its officers, employees, subsidiaries, affiliates, and distributors harmless against all claims, costs, damages, and expenses, and reasonable attorney fees arising out of, directly or indirectly, any claim of personal injury or death associated with such unintended or unauthorized use, even if such claim alleges that SCILLC was negligent regarding the design or manufacture of the part. SCILLC is an Equal Opportunity/Affirmative Action Employer. This literature is subject to all applicable copyright laws and is not for resale in any manner.

PUBLICATION ORDERING INFORMATION

LITERATURE FULFILLMENT:

Literature Distribution Center for ON Semiconductor
P.O. Box 5163, Denver, Colorado 80217 USA
Phone: 303-675-2175 or 800-344-3860 Toll Free USA/Canada
Fax: 303-675-2176 or 800-344-3867 Toll Free USA/Canada
Email: orderlit@onsemi.com

N. American Technical Support: 800-282-9855 Toll Free
USA/Canada
Europe, Middle East and Africa Technical Support:
Phone: 421 33 790 2910
Japan Customer Focus Center
Phone: 81-3-5817-1050

ON Semiconductor Website: www.onsemi.com

Order Literature: <http://www.onsemi.com/orderlit>

For additional information, please contact your local Sales Representative

Looking for pricing, stock, or lifecycle information?

Click below to explore more details on WIN SOURCE:

- ⊖ [View CAT803RTBI-GT3 on WIN SOURCE](#)
- ⊖ [ON Semiconductor Information](#)

Optimize Your Supply Chain with WIN SOURCE Solutions

- ✓ Global Sourcing Solution
- ✓ Obsolete Management
- ✓ Cost Control Management
- ✓ Shortage Management
- ✓ Alternative Solution
- ✓ Excess Inventory Management