



THE DATASHEET OF AS21P2TLRQ



Low voltage 0.5 Ω max dual single-pole double-throw analog switch with break-before-make

Datasheet - production data

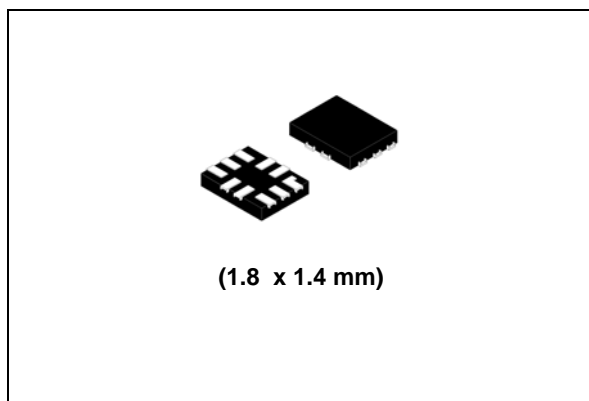

Description

The AS21P2TLR is a high-speed CMOS single-pole double-throw (SPDT) analog switch or dual 2:1 multiplexer/demultiplexer bus switch fabricated using silicon gate C²MOS technology. Designed to operate from 1.65 to 4.3 V, this device is ideal for portable applications.

It offers very low ON resistance ($R_{ON} < 0.5 \Omega$) at $V_{CC} = 3.6$ V. The n_{IN} inputs are provided to control the independent channel switches $nS1$ and $nS2$. The switches $nS1$ are ON (connected to common ports Dn) when the n_{IN} input is held high and OFF (state of high impedance exists between the two ports) when n_{IN} is held low. The switches $nS2$ are ON (connected to common ports Dn) when the n_{IN} input is held low and OFF (state of high impedance exists between the two ports) when n_{IN} is held high. Additional key features are fast switching speed, break-before-make delay time and ultralow power consumption. All inputs and outputs are equipped with protection circuits against static discharge, giving them ESD and excess transient voltage immunity.

Features

- Ultra low power dissipation: $I_{CC} = 0.2 \mu A$ (max.) at $T_A = 85 \text{ }^\circ C$
- Low ON resistance $V_{IN} = 0$ V:
 - $R_{ON} = 0.50 \Omega$ (max. $T_A = 25 \text{ }^\circ C$) at $V_{CC} = 4.3$ V
 - $R_{ON} = 0.50 \Omega$ (max. $T_A = 25 \text{ }^\circ C$) at $V_{CC} = 3.6$ V
- Wide operating voltage range: V_{CC} (OPR) = 1.65 to 4.3 V single supply
- 4.3 V tolerant and 1.8 V compatible threshold on digital control input at $V_{CC} = 2.3$ to 4.3 V
- Latch-up performance exceeds 300 mA (JESD 17)
- ESD performance: HMB > 2 kV (MIL STD 883 method 3015)

Table 1. Device summary

Order code	Package	Packing
AS21P2TLRQ	QFN10L (1.8 x 1.4 mm)	Tape and reel

Contents

1	Pin settings	3
	1.1 Pin connection	3
	1.2 Pin description	4
2	Input equivalent circuit and truth table	5
3	Maximum rating	6
4	Electrical characteristics	7
5	Test circuit	10
6	Package mechanical data	16
7	Revision history	21

1 Pin settings

1.1 Pin connection

Figure 1. Pin connection (top through view)

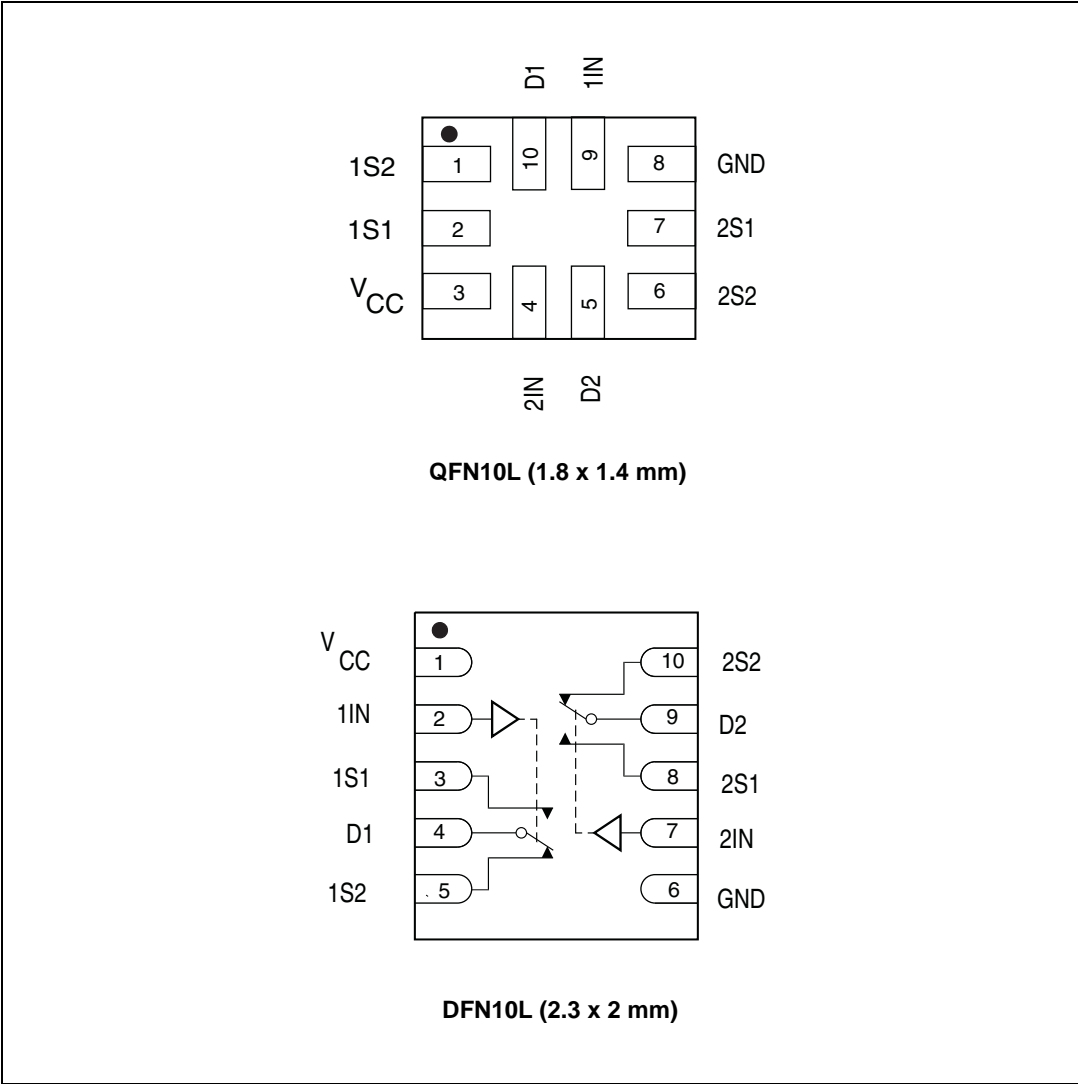

1.2 Pin description

Table 2. Pin description

Pin number	Symbol	Name and function
1	1S2	Independent channel
2	1S1	Independent channel
3	V _{CC}	Positive voltage supply
4	2IN	Control
5	D2	Common channel
6	2S2	Independent channel
7	2S1	Independent channel
8	GND	Ground (0 V)
9	1IN	Control
10	D1	Common channel

Note: Exposed pad must be soldered to a floating plane. Do NOT connect to power or ground.

2 Input equivalent circuit and truth table

Figure 2. Input equivalent circuit

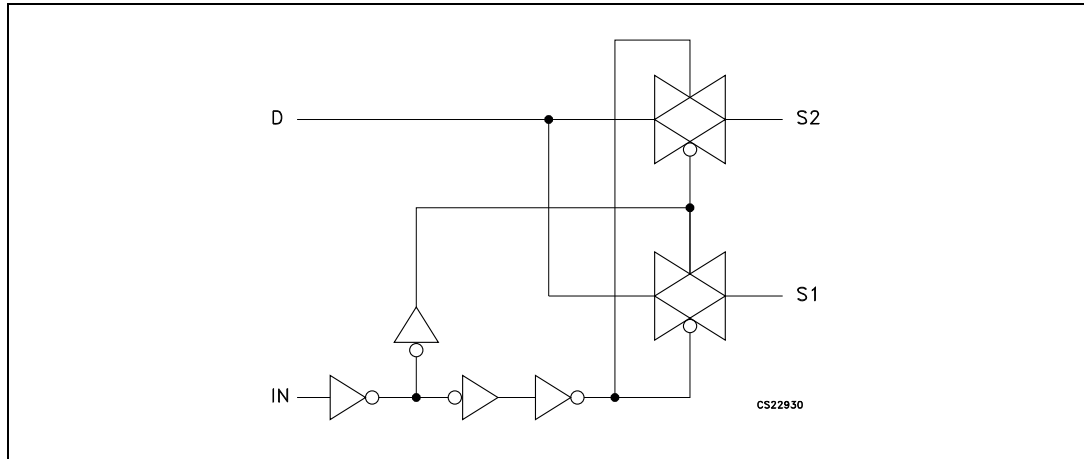

Table 3. Truth table

IN	Switch S1	Switch S2
H	ON	OFF ⁽¹⁾
L	OFF ⁽¹⁾	ON

1. High impedance.

3 Maximum rating

Stressing the device above the rating listed in the “Absolute maximum ratings” table may cause permanent damage to the device. These are stress ratings only and operation of the device at these or any other conditions above those indicated in the Operating sections of this specification is not implied. Exposure to absolute maximum rating conditions for extended periods may affect device reliability. Refer also to the STMicroelectronics SURE Program and other relevant quality documents.

Table 4. Absolute maximum ratings

Symbol	Parameter	Value	Unit
V_{CC}	Supply voltage	-0.5 to 5.5	V
V_I	DC input voltage	-0.5 to $V_{CC} + 0.5$	V
V_{IC}	DC control input voltage	-0.5 to 5.5	V
V_O	DC output voltage	-0.5 to $V_{CC} + 0.5$	V
I_{IKC}	DC input diode current on control pin ($V_{IN} < 0$ V)	-50	mA
I_{IK}	DC Input diode current ($V_{IN} < 0$ V)	± 50	mA
I_{OK}	DC output diode current	± 20	mA
I_O	DC output current	± 300	mA
I_{OP}	DC output current peak (pulse at 1 ms, 10% duty cycle)	± 500	mA
I_{CC} or I_{GND}	DC V_{CC} or ground current	± 100	mA
P_D	Power dissipation at $T_A = 70$ °C	1120	mW
T_{STG}	Storage temperature	-65 to 150	°C
T_L	Lead temperature (10 sec)	300	°C

Table 5. Recommended operating conditions

Symbol	Parameter	Value	Unit
V_{CC}	Supply voltage	1.65 to 4.3	V
V_I	Input voltage	0 to V_{CC}	V
V_{IC}	Control input voltage	0 to 4.3	V
V_O	Output voltage	0 to V_{CC}	V
T_{op}	Operating temperature	-40 to 85	°C
dt/dv	Input rise and fall time control input	$V_{CC} = 1.65$ to 2.7 V	0 to 20
		$V_{CC} = 3.0$ to 4.3 V	0 to 10
			ns/V

4 Electrical characteristics

Table 6. DC specifications

Symbol	Parameter	V _{CC} (V)	Test condition	Value					Unit
				T _A = 25 °C			-40 to 85 °C		
				Min	Typ	Max	Min	Max	
V _{IH}	High level input voltage	1.65 – 1.95		0.65 V _{CC}			0.65 V _{CC}		V
		2.3 – 2.5		1.2			1.2		
		2.7 – 3.0		1.3			1.3		
		3.0 – 3.6		1.4			1.4		
		4.3		1.5			1.5		
V _{IL}	Low level input voltage	1.65 – 1.95				0.25		0.25	V
		2.3 – 2.5				0.25		0.25	
		2.7 – 3.0				0.25		0.25	
		3.0 – 3.6				0.30		0.30	
		4.3				0.40		0.40	
R _{ON}	Switch ON resistance	4.3	V _S = 0 V to V _{CC} I _S = 100 mA		0.45	0.50		0.60	Ω
		3.6			0.45	0.50		0.60	
		3.0			0.50	0.55		0.60	
		2.3			0.60	0.70		0.80	
		1.8			0.80	0.9		1.0	
ΔR _{ON}	ON resistance match between channels ^{(1),(2)}	2.7	V _S = 1.5 V I _S = 100 mA		0.1			Ω	
R _{FLAT}	ON resistance flatness ⁽³⁾	4.3	V _S = 1.5 V I _S = 100 mA		0.15	0.20		0.20	Ω
		3.6			0.15	0.20		0.20	
		3.0			0.15	0.20		0.20	
		2.7			0.15	0.20		0.20	
		2.3			0.20	0.25		0.25	
		1.65			0.35	0.45		0.45	
I _{OFF}	OFF state leakage current (nSn), (Dn)	4.3	V _S = 0.3 or 4 V			±20		±100	nA
I _{IN}	Input leakage current	0 – 4.3	V _{IN} = 0 to 4.3 V			±0.05		±1	μA
I _{CC}	Quiescent supply current ⁽¹⁾	1.65 – 4.3	V _{IN} = V _{CC} or GND			±0.05		±0.2	μA

Table 6. DC specifications (continued)

Symbol	Parameter	V _{CC} (V)	Test condition	Value					Unit
				T _A = 25 °C			-40 to 85 °C		
				Min	Typ	Max	Min	Max	
I _{CCLV}	Quiescent supply current low voltage driving	4.3	V _{1IN} , V _{2IN} = 1.65 V		±37	±50		±100	μA
			V _{1IN} , V _{2IN} = 1.80 V		±33	±40		±50	
			V _{1IN} , V _{2IN} = 2.60 V		±12	±20		±30	

1. Guaranteed by design.
2. ΔR_{ON} = R_{ON(max)} - R_{ON(min)}.
3. Flatness is defined as the difference between the maximum and minimum value of on-resistance as measured over the specified analog signal ranges.

Table 7. AC electrical characteristics (C_L = 35 pF, R_L = 50 Ω, t_r = t_f ≤ 6 ns)

Symbol	Parameter	V _{CC} (V)	Test condition	Value					Unit
				T _A = 25 °C			-40 to 85 °C		
				Min	Typ	Max	Min	Max	
t _{PLH} , t _{PHL}	Propagation delay	1.65 – 1.95			0.45				ns
		2.3 – 2.7			0.40				
		3.0 – 3.3			0.30				
		3.6 – 4.3			0.30				
t _{ON}	Turn-ON time	1.65 – 1.95	V _S = 0.8 V		120				ns
		2.3 – 2.7	V _S = 1.5 V		65	85		90	
		3.0 – 3.3			42	55		65	
		3.6 – 4.3			40	55		65	
t _{OFF}	Turn-OFF time	1.65 – 1.95	V _S = 0.8 V		45				ns
		2.3 – 2.7	V _S = 1.5 V		18	30		40	
		3.0 – 3.3			16	30		40	
		3.6 – 4.3			15	30		40	
t _D	Break-before make time delay	1.65 – 1.95	C _L = 35 pF R _L = 50 Ω V _S = 1.5 V	2	80				ns
		2.3 – 2.7		2	60				
		3.0 – 3.3		2	55				
		3.6 – 4.3		2	50				

Table 7. AC electrical characteristics ($C_L = 35 \text{ pF}$, $R_L = 50 \text{ } \Omega$, $t_r = t_f \leq 6 \text{ ns}$) (continued)

Symbol	Parameter	V_{CC} (V)	Test condition	Value					Unit
				$T_A = 25 \text{ } ^\circ\text{C}$			$-40 \text{ to } 85 \text{ } ^\circ\text{C}$		
				Min	Typ	Max	Min	Max	
Q	Charge injection	1.65 – 1.95	$C_L = 100 \text{ pF}$ $R_L = 1 \text{ M}\Omega$ $V_{GEN} = 0 \text{ V}$ $R_{GEN} = 0 \text{ } \Omega$		43				pC
		2.3 – 2.7			51				
		3.0 – 3.3			51				
		3.6 – 4.3			49				

Table 8. Analog switch characteristics ($C_L = 5 \text{ pF}$, $R_L = 50 \text{ } \Omega$, $T_A = 25 \text{ } ^\circ\text{C}$)

Symbol	Parameter	V_{CC} (V)	Test condition	Value					Unit
				$T_A = 25 \text{ } ^\circ\text{C}$			$-40 \text{ to } 85 \text{ } ^\circ\text{C}$		
				Min	Typ	Max	Min	Max	
OIRR	Off isolation ⁽¹⁾	1.65 – 4.3	$V_S = 1 \text{ V}_{RMS}$ $f = 100 \text{ kHz}$		-66				dB
Xtalk	Crosstalk	1.65 – 4.3	$V_S = 1 \text{ V}_{RMS}$ $f = 100 \text{ kHz}$		-72				dB
THD	Total harmonic distortion	2.3 – 4.3	$R_L = 600 \text{ } \Omega$ $V_{IN} = 2V_{PP}$ $f = 20 \text{ Hz to } 20 \text{ kHz}$		0.02				%
BW	-3 dB bandwidth	1.65 – 4.3	$R_L = 50 \text{ } \Omega$		55				MHz
C_{IN}	Control pin input capacitance				5				pF
C_{Sn}	Sn port capacitance	3.3	$f = 1 \text{ MHz}$		40				
C_D	D port capacitance when switch is enabled	3.3	$f = 1 \text{ MHz}$		114				

1. Off Isolation = $20 \text{ Log}_{10} (V_D/V_S)$, V_D = output. V_S = input at off switch.

Figure 5. OFF isolation

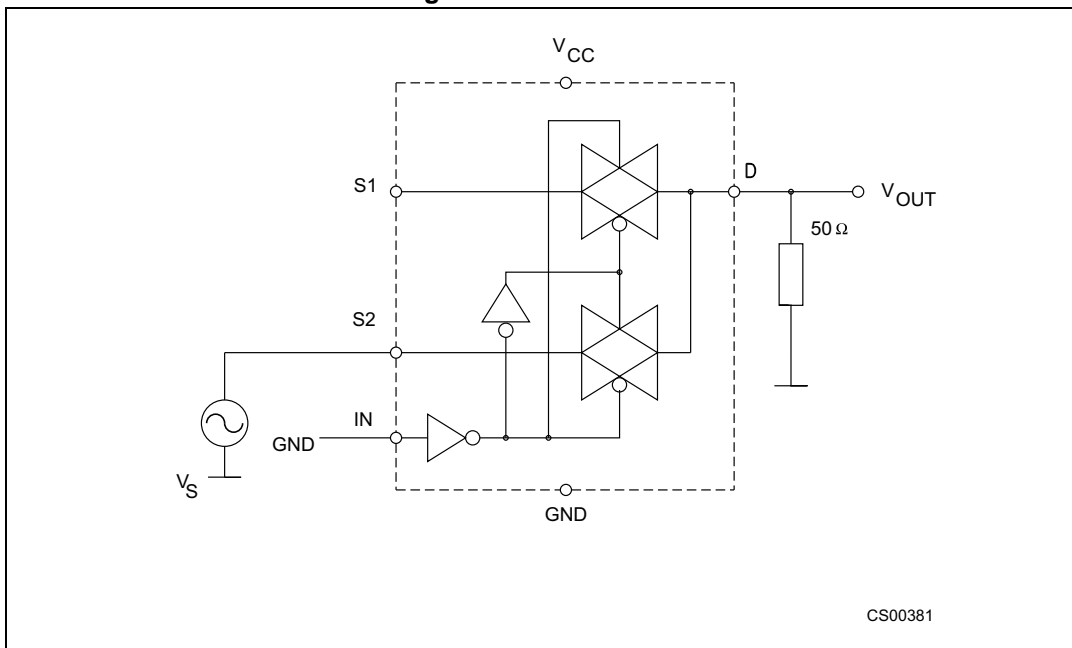

Figure 6. Bandwidth

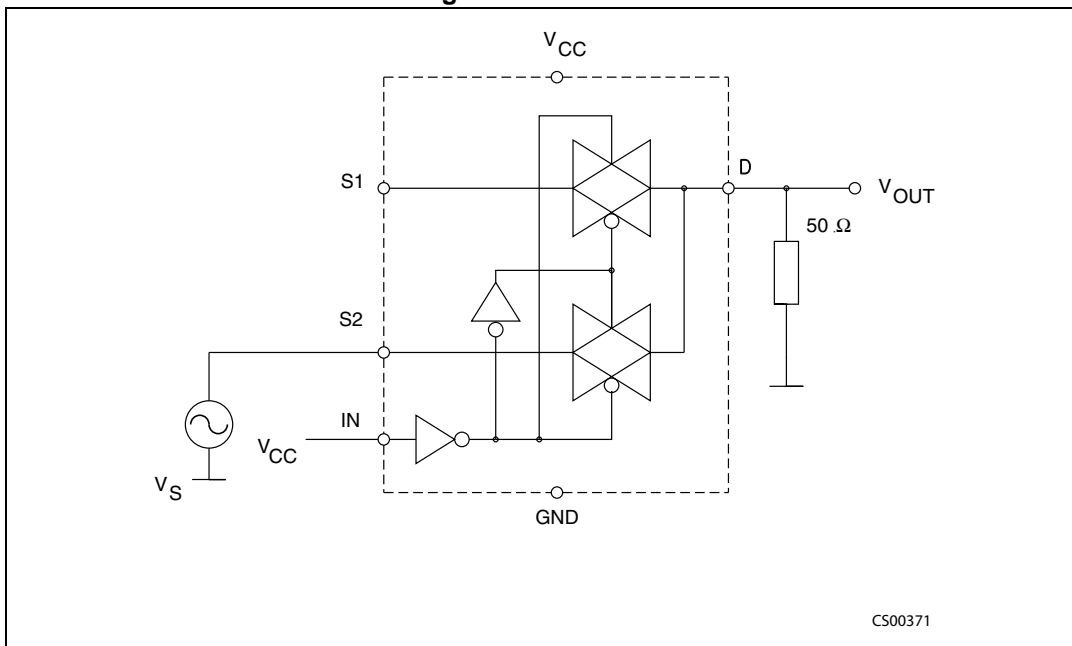

Figure 7. Channel-to-channel crosstalk

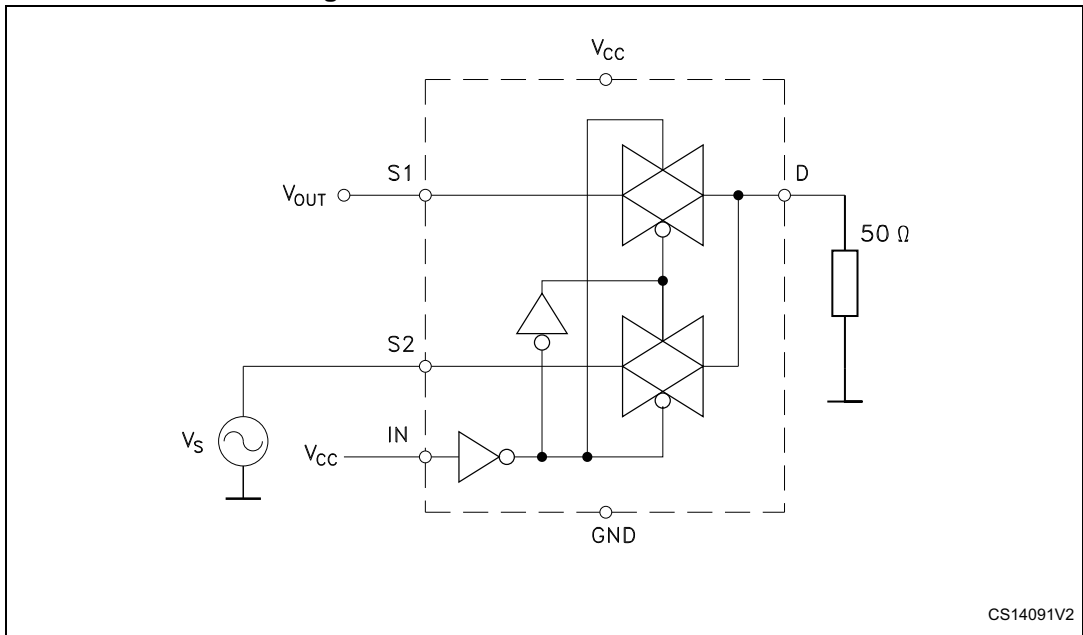
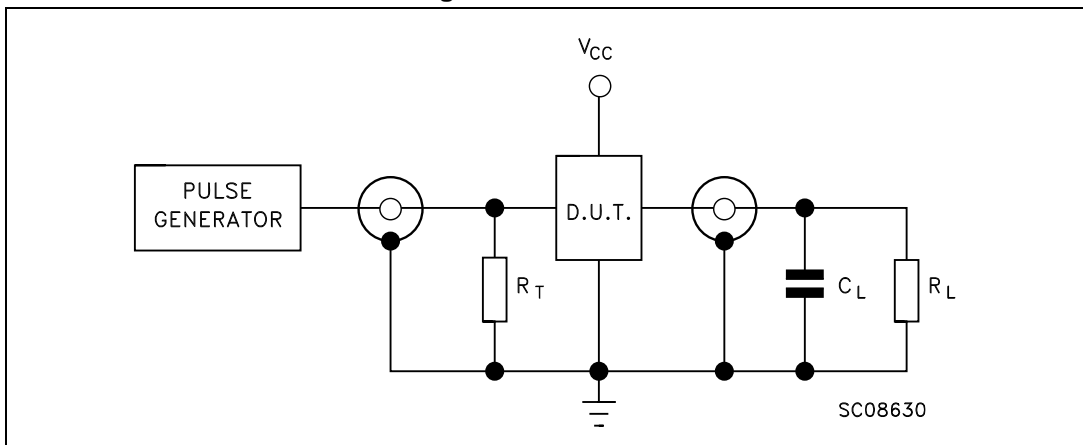

Figure 8. Test circuit



1. $C_L = 5/35$ pF or equivalent (includes jig and probe capacitance).
 $R_L = 50 \Omega$ or equivalent.
 $R_T = Z_{OUT}$ of pulse generator (typically 50Ω).

Figure 9. Break-before-make time delay

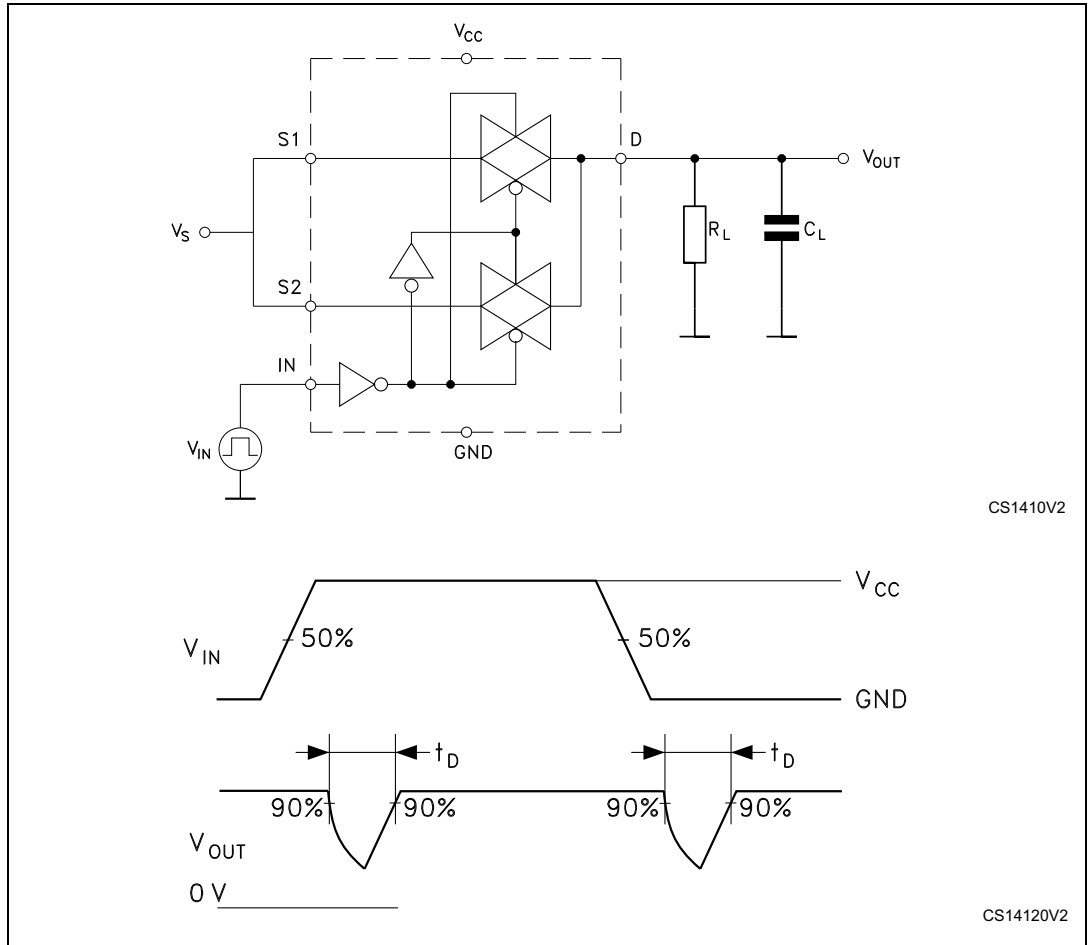

Figure 10. Charge injection ($V_{GEN} = 0\text{ V}$, $R_{GEN} = 0\ \Omega$, $R_L = 1\text{ M}\Omega$, $C_L = 100\text{ pF}$)

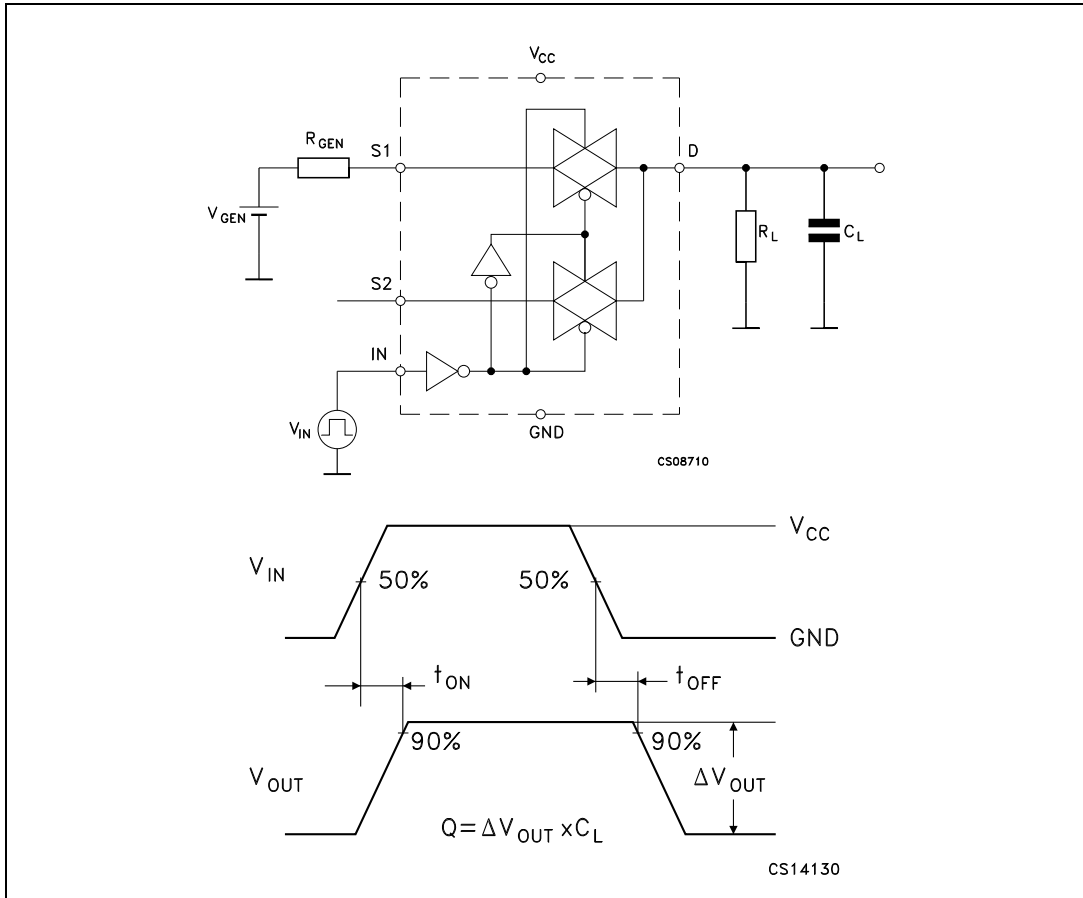

Figure 11. Turn-on, turn-off delay time

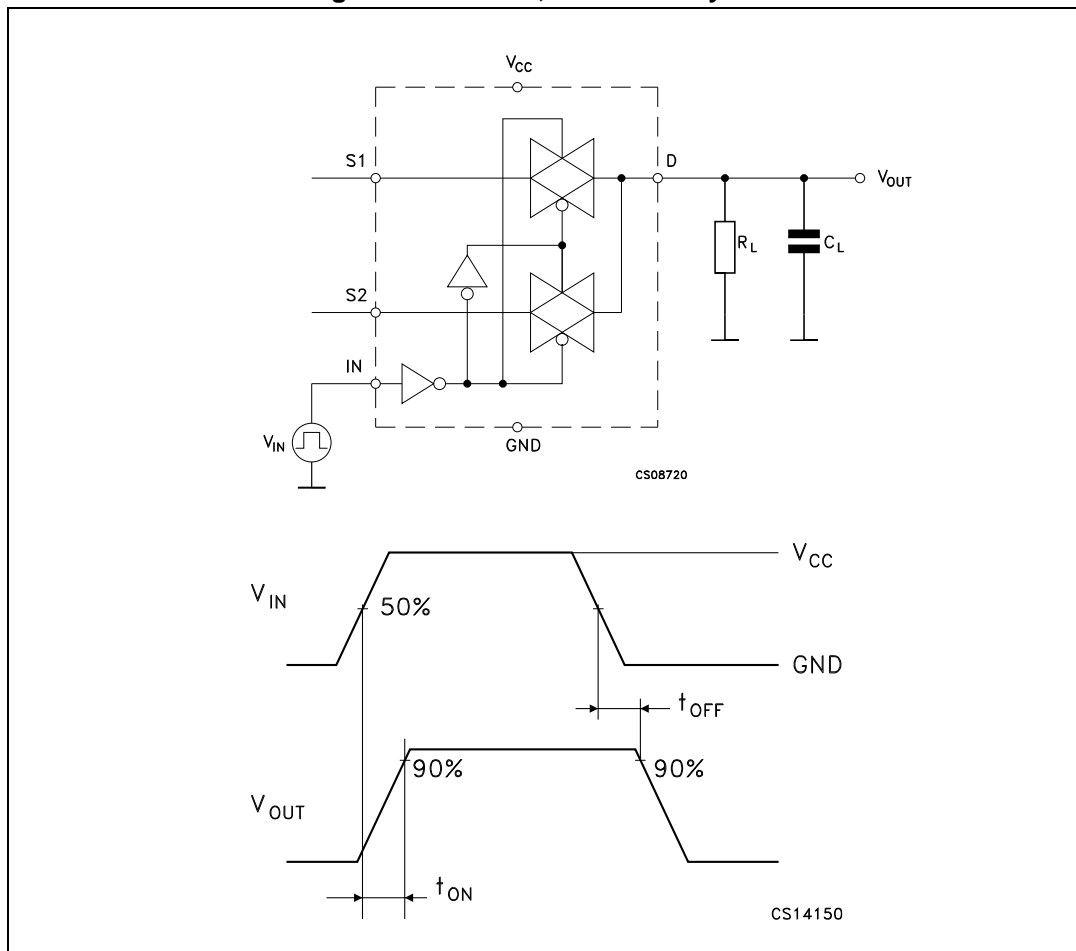
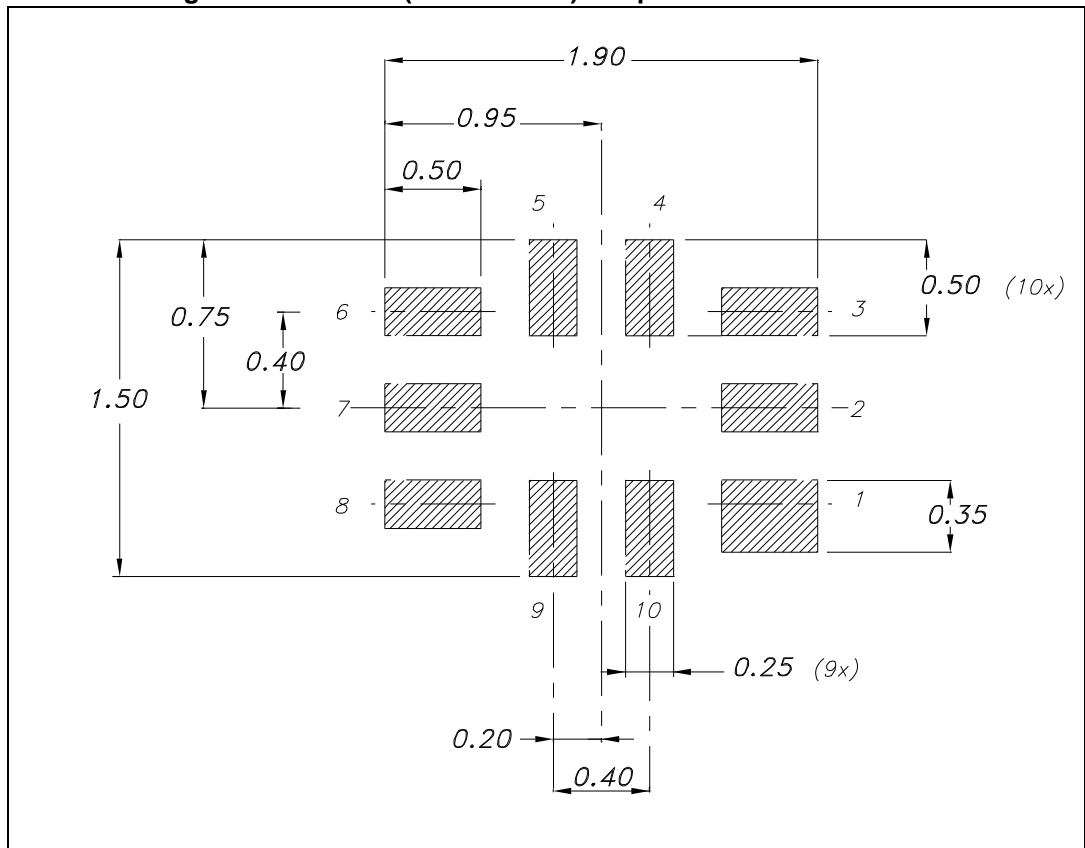

Table 9. QFN10L (1.8 x 1.4 mm) mechanical data

Symbol	millimeters			inches		
	Nom	Min	Max	Nom	Min	Max
A	0.50	0.45	0.55	0.020	0.017	0.021
A1	0.02	0	0.05	0.001	0	0.002
A3	0.127			0.005	0	0
b	0.20	0.15	0.25	0.007	0.006	0.010
D	1.80	1.70	1.90	0.070	0.066	0.074
E	1.40	1.30	1.50	0.055	0.051	0.059
e	0.40			0.015		
L	0.40	0.30	0.50	0.015	0.011	0.020

Figure 13. QFN10L (1.8 x 1.4 mm) footprint recommendations



1. Drawing not to scale.

Figure 14. QFN10L (1.8 x 1.4 mm) carrier type

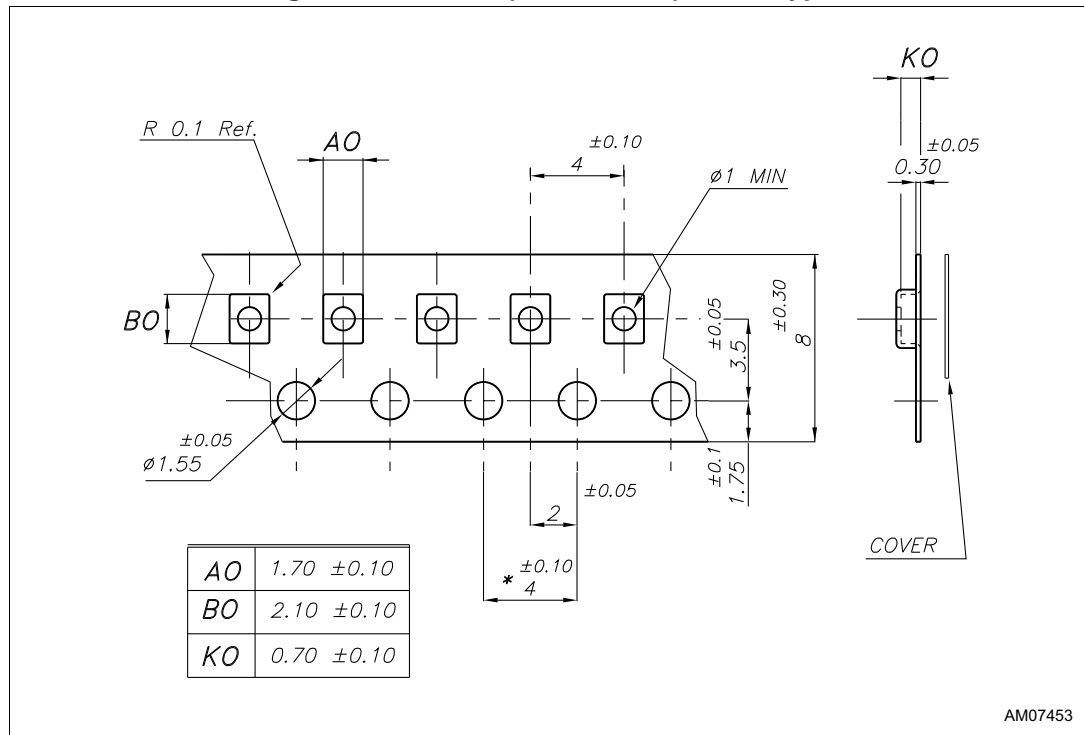

1. Drawing not to scale.

Figure 15. QFN10L (1.8 x 1.4 mm) reel information - back view

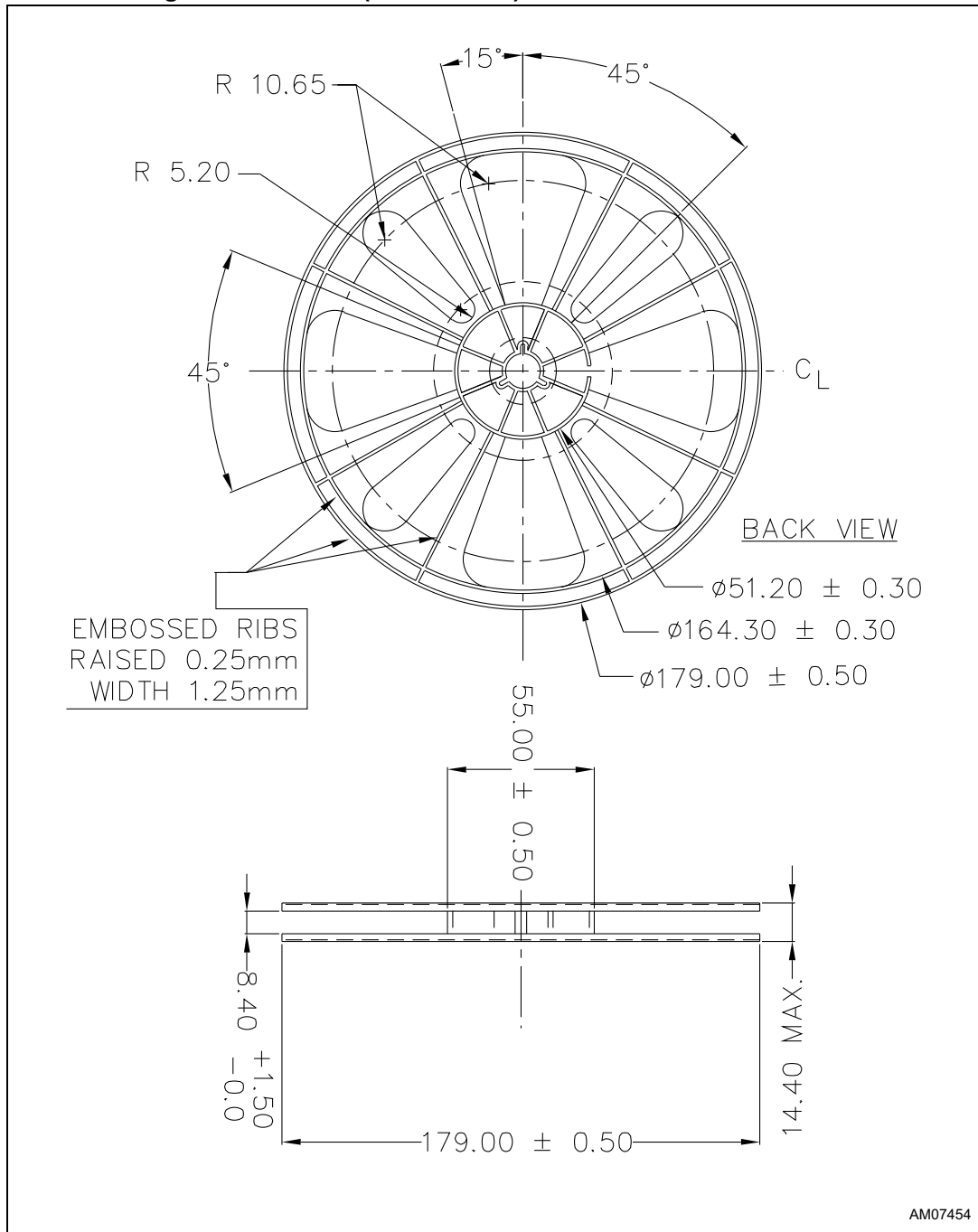

AM07454

1. Drawing not to scale.

Figure 16. QFN10L (1.8 x 1.4 mm) reel information - front side

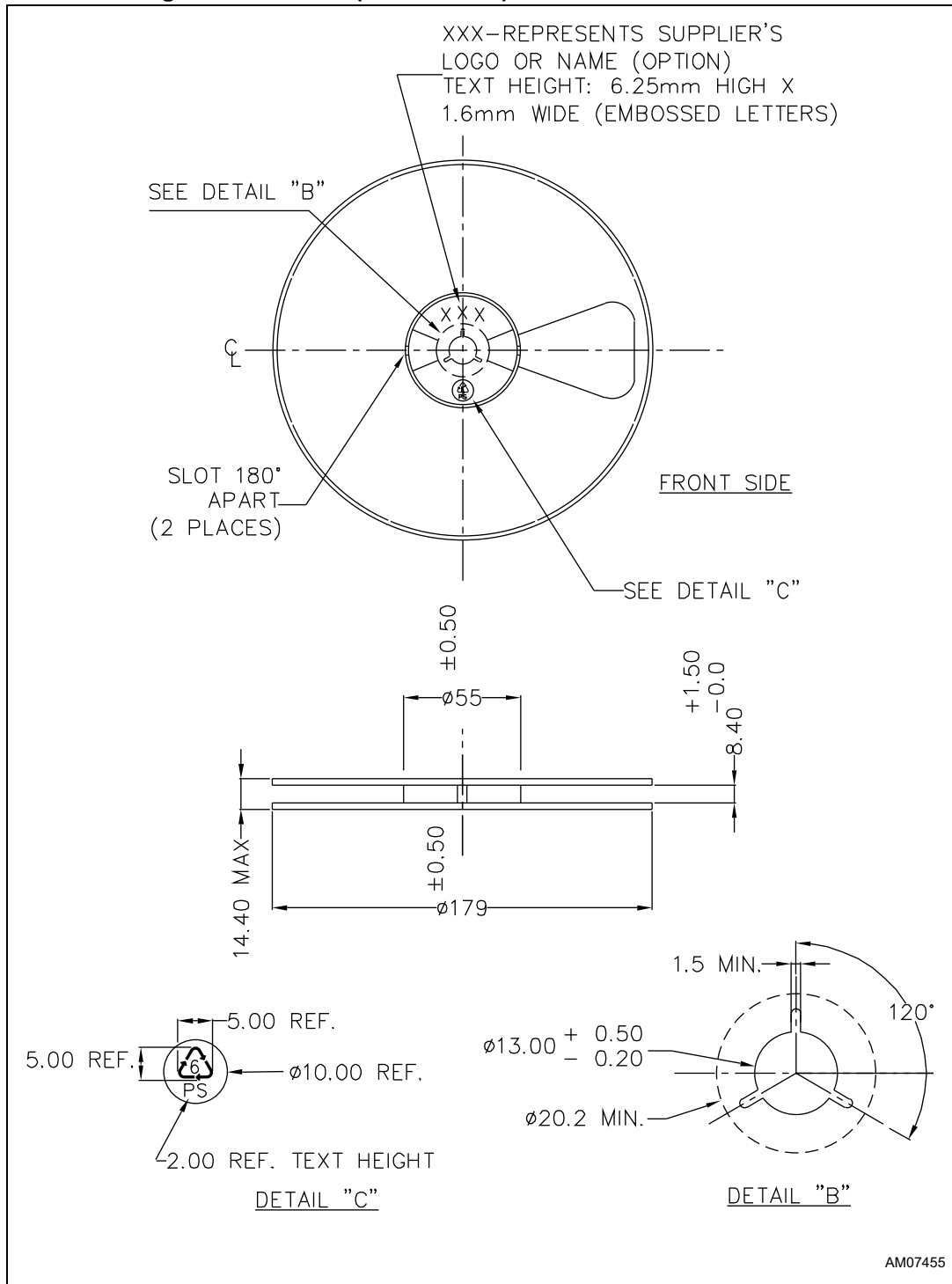

1. Drawing not to scale.

7 Revision history

Table 10. Document revision history

Date	Revision	Changes
07-Mar-2014	1	Initial release.

Please Read Carefully:

Information in this document is provided solely in connection with ST products. STMicroelectronics NV and its subsidiaries ("ST") reserve the right to make changes, corrections, modifications or improvements, to this document, and the products and services described herein at any time, without notice.

All ST products are sold pursuant to ST's terms and conditions of sale.

Purchasers are solely responsible for the choice, selection and use of the ST products and services described herein, and ST assumes no liability whatsoever relating to the choice, selection or use of the ST products and services described herein.

No license, express or implied, by estoppel or otherwise, to any intellectual property rights is granted under this document. If any part of this document refers to any third party products or services it shall not be deemed a license grant by ST for the use of such third party products or services, or any intellectual property contained therein or considered as a warranty covering the use in any manner whatsoever of such third party products or services or any intellectual property contained therein.

UNLESS OTHERWISE SET FORTH IN ST'S TERMS AND CONDITIONS OF SALE ST DISCLAIMS ANY EXPRESS OR IMPLIED WARRANTY WITH RESPECT TO THE USE AND/OR SALE OF ST PRODUCTS INCLUDING WITHOUT LIMITATION IMPLIED WARRANTIES OF MERCHANTABILITY, FITNESS FOR A PARTICULAR PURPOSE (AND THEIR EQUIVALENTS UNDER THE LAWS OF ANY JURISDICTION), OR INFRINGEMENT OF ANY PATENT, COPYRIGHT OR OTHER INTELLECTUAL PROPERTY RIGHT.

ST PRODUCTS ARE NOT DESIGNED OR AUTHORIZED FOR USE IN: (A) SAFETY CRITICAL APPLICATIONS SUCH AS LIFE SUPPORTING, ACTIVE IMPLANTED DEVICES OR SYSTEMS WITH PRODUCT FUNCTIONAL SAFETY REQUIREMENTS; (B) AERONAUTIC APPLICATIONS; (C) AUTOMOTIVE APPLICATIONS OR ENVIRONMENTS, AND/OR (D) AEROSPACE APPLICATIONS OR ENVIRONMENTS. WHERE ST PRODUCTS ARE NOT DESIGNED FOR SUCH USE, THE PURCHASER SHALL USE PRODUCTS AT PURCHASER'S SOLE RISK, EVEN IF ST HAS BEEN INFORMED IN WRITING OF SUCH USAGE, UNLESS A PRODUCT IS EXPRESSLY DESIGNATED BY ST AS BEING INTENDED FOR "AUTOMOTIVE, AUTOMOTIVE SAFETY OR MEDICAL" INDUSTRY DOMAINS ACCORDING TO ST PRODUCT DESIGN SPECIFICATIONS. PRODUCTS FORMALLY ESCC, QML OR JAN QUALIFIED ARE DEEMED SUITABLE FOR USE IN AEROSPACE BY THE CORRESPONDING GOVERNMENTAL AGENCY.

Resale of ST products with provisions different from the statements and/or technical features set forth in this document shall immediately void any warranty granted by ST for the ST product or service described herein and shall not create or extend in any manner whatsoever, any liability of ST.

ST and the ST logo are trademarks or registered trademarks of ST in various countries.

Information in this document supersedes and replaces all information previously supplied.

The ST logo is a registered trademark of STMicroelectronics. All other names are the property of their respective owners.

© 2014 STMicroelectronics - All rights reserved

STMicroelectronics group of companies

Australia - Belgium - Brazil - Canada - China - Czech Republic - Finland - France - Germany - Hong Kong - India - Israel - Italy - Japan - Malaysia - Malta - Morocco - Philippines - Singapore - Spain - Sweden - Switzerland - United Kingdom - United States of America

www.st.com

Looking for pricing, stock, or lifecycle information?

Click below to explore more details on WIN SOURCE:

-  [View AS21P2TLRQ](#) on WIN SOURCE
-  [STMicroelectronics](#) Information

Optimize Your Supply Chain with WIN SOURCE Solutions

-  Global Sourcing Solution
-  Obsolete Management
-  Cost Control Management
-  Shortage Management
-  Alternative Solution
-  Excess Inventory Management