

# 74VHC4051AFT, 74VHC4052AFT, 74VHC4053AFT

## 1. Functional Description

74VHC4051AFT: 8-Channel Analog Multiplexer/Demultiplexer  
 74VHC4052AFT: Dual 4-Channel Analog Multiplexer/Demultiplexer  
 74VHC4053AFT: Triple 2-Channel Analog Multiplexer/Demultiplexer

## 2. General

The 74VHC4051AFT, 74VHC4052AFT and 74VHC4053AFT are high-speed, low-voltage drive analog multiplexer/demultiplexers using silicon gate CMOS technology. In 3 V and 5 V systems these can achieve high-speed operation with the low power dissipation that is a feature of CMOS.

The 74VHC4051AFT, 74VHC4052AFT and 74VHC4053AFT offer analog/digital signal selection as well as mixed signals. The 74VHC4051AFT has an 8-channel configuration, the 74VHC4052AFT has an 4-channel  $\times 2$  configuration, and the 74VHC4053AFT has a 2-channel  $\times 3$  configuration.

The switches for each channel are turned ON by the control pin digital signals.

All control inputs are equipped with a newly developed input protection circuit that avoids the need for a diode on the plus side (forward side from the input to the  $V_{CC}$ ). As a result, for example, 5.5 V signals can be permitted on the inputs even when the power supply voltage to the circuits is off. As a result of this input power protection, the 74VHC4051AFT, 74VHC4052AFT and 74VHC4053AFT can be used in a variety of applications, including in the system which has two power supplies, and in battery backup circuits.

## 3. Features

- (1) AEC-Q100 (Rev. H) (Note 1)
- (2) Wide operating temperature range:  $T_{opr} = -40$  to  $125$  °C
- (3) Low ON-resistance:  $R_{ON} = 45$   $\Omega$  (typ.) ( $V_{CC} = 3.0$  V)  
 $R_{ON} = 24$   $\Omega$  (typ.) ( $V_{CC} = 4.5$  V)
- (4) Low power dissipation:  $I_{CC} = 2.0$   $\mu$ A (max) ( $T_a = 25$ °C)
- (5) High noise immunity:  $V_{IL} = 0.8$  V (max)  $V_{CC} = 3.0$  V  
 $V_{IH} = 2.0$  V (min)  $V_{CC} = 3.0$  V
- (6) Power down protection is provided on all control inputs.

Note 1: This device is compliant with the reliability requirements of AEC-Q100. For details, contact your Toshiba sales representative.

## 4. Packaging

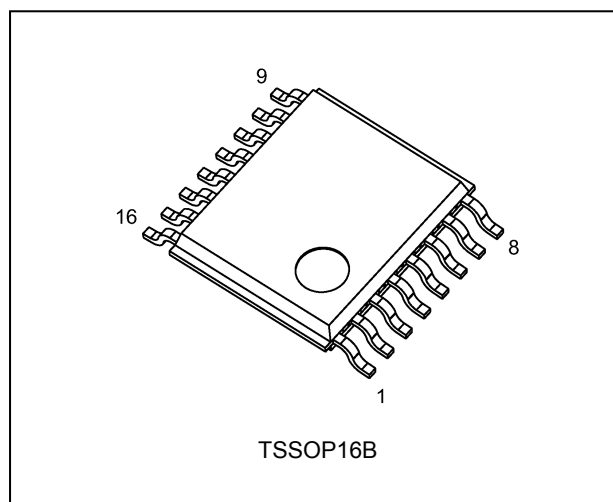

Start of commercial production

2013-06

### 5. Pin Assignment

74VHC4051AFT

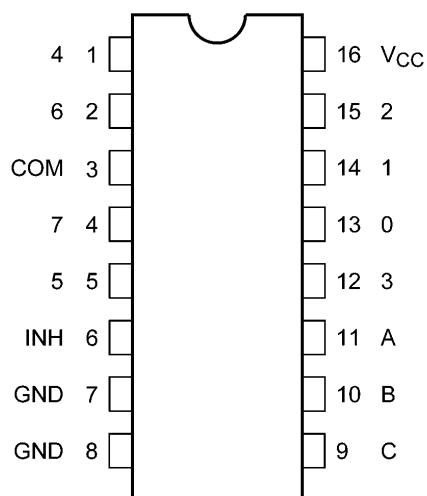

74VHC4052AFT

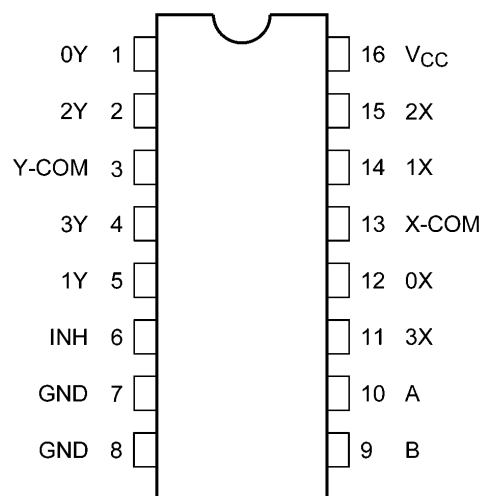

74VHC4053AFT

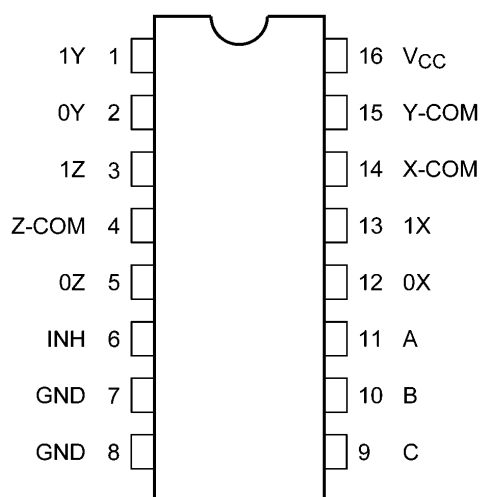

### 6. Marking

74VHC4051AFT

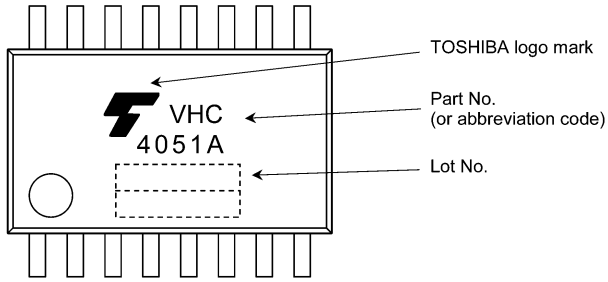

74VHC4052AFT

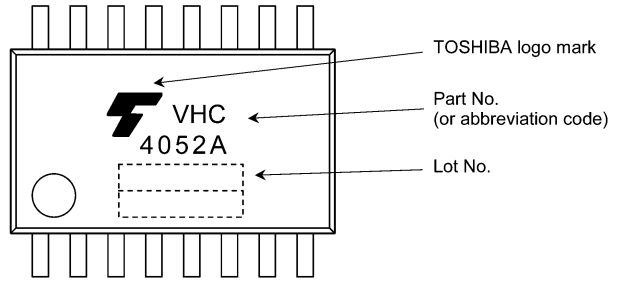

74VHC4053AFT

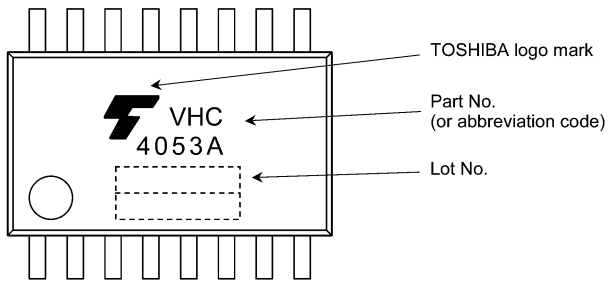

### 7. System Diagram

74VHC4051AFT

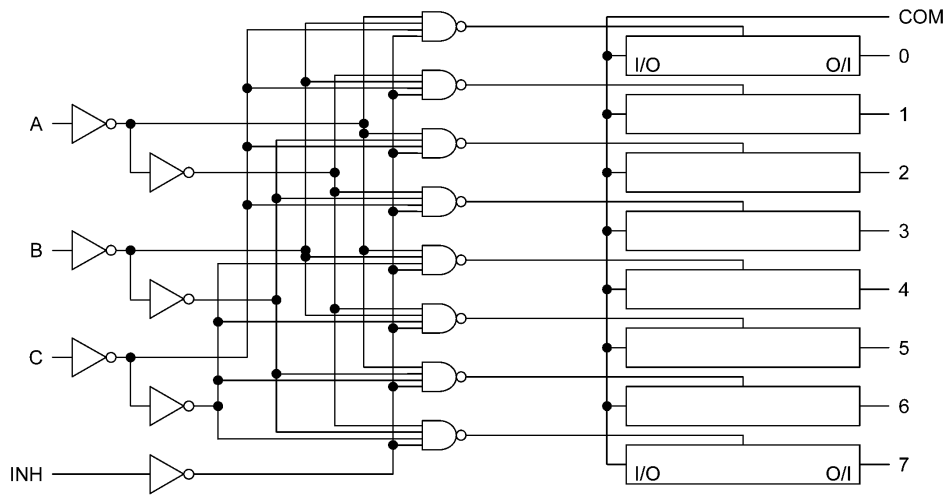

74VHC4052AFT

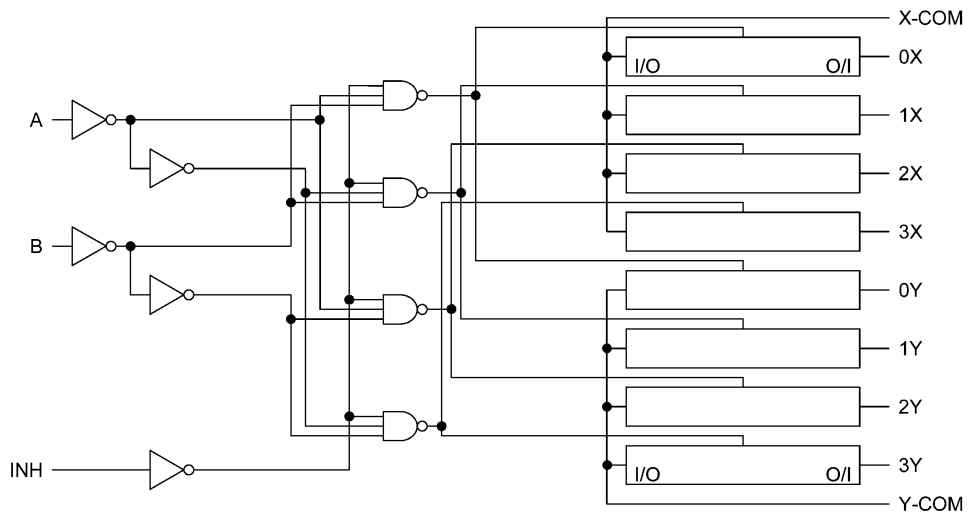

74VHC4053AFT

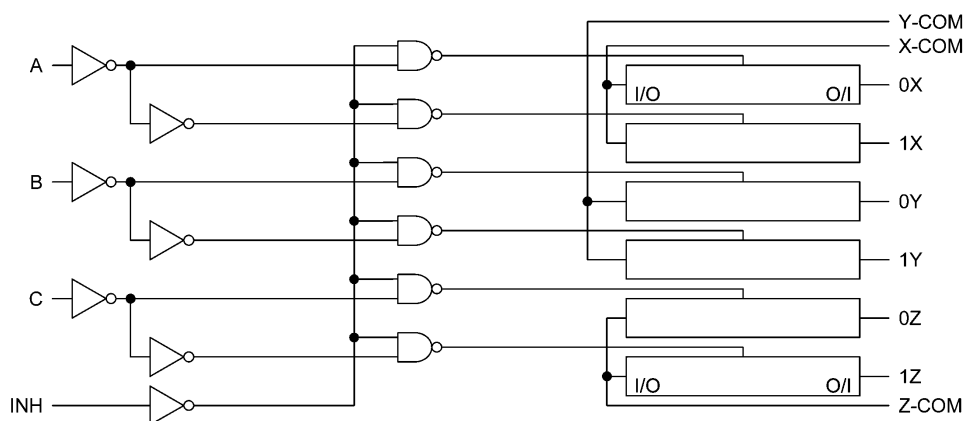

### 8. Truth Table

Input Inhibit	Input C*	Input B	Input A	ON Channel 74VHC4051AFT	ON Channel 74VHC4052AFT	ON Channel 74VHC4053AFT
L	L	L	L	0	0X, 0Y	0X, 0Y, 0Z
L	L	L	H	1	1X, 1Y	1X, 0Y, 0Z
L	L	H	L	2	2X, 2Y	0X, 1Y, 0Z
L	L	H	H	3	3X, 3Y	1X, 1Y, 0Z
L	H	L	L	4	—	0X, 0Y, 1Z
L	H	L	H	5	—	1X, 0Y, 1Z
L	H	H	L	6	—	0X, 1Y, 1Z
L	H	H	H	7	—	1X, 1Y, 1Z
H	X	X	X	None	None	None

X: Don't care

\*: Except 74VHC4052AFT

### 9. Absolute Maximum Ratings (Note)

Characteristics	Symbol	Note	Rating	Unit
Supply voltage	$V_{CC}$		-0.5 to 7.0	V
Input voltage	$V_{IN}$		-0.5 to 7.0	V
Switch I/O voltage	$V_{I/O}$		-0.5 to $V_{CC} + 0.5$	V
Input diode current	$I_{IK}$		-20	mA
I/O diode current	$I_{I/OK}$		$\pm 25$	mA
Switch through current	$I_T$		$\pm 25$	mA
$V_{CC}$ /ground current	$I_{CC}$		$\pm 50$	mA
Power dissipation	$P_D$	(Note 1)	180	mW
Storage temperature	$T_{stg}$		-65 to 150	°C

Note: Exceeding any of the absolute maximum ratings, even briefly, lead to deterioration in IC performance or even destruction.

Using continuously under heavy loads (e.g. the application of high temperature/current/voltage and the significant change in temperature, etc.) may cause this product to decrease in the reliability significantly even if the operating conditions (i.e. operating temperature/current/voltage, etc.) are within the absolute maximum ratings and the operating ranges.

Please design the appropriate reliability upon reviewing the Toshiba Semiconductor Reliability Handbook ("Handling Precautions"/"Derating Concept and Methods") and individual reliability data (i.e. reliability test report and estimated failure rate, etc).

Note 1: 180 mW in the range of  $T_a = -40$  to  $85$  °C. From  $T_a = 85$  to  $125$  °C a derating factor of  $-3.25$  mW/°C shall be applied until 50 mW.

### 10. Operating Ranges (Note)

Characteristics	Symbol	Test Condition	Rating	Unit
Supply voltage	$V_{CC}$		2.0 to 5.5	V
Input voltage	$V_{IN}$		0 to 5.5	V
Switch I/O voltage	$V_S$		0 to $V_{CC}$	V
Operating temperature	$T_{opr}$		-40 to 125	°C
Input rise and fall times	dt/dv	$V_{CC} = 2.5 \pm 0.2$ V	0 to 200	ns/V
		$V_{CC} = 3.3 \pm 0.3$ V	0 to 100	
		$V_{CC} = 5 \pm 0.5$ V	0 to 20	

Note: The operating ranges must be maintained to ensure the normal operation of the device.

Unused inputs must be tied to either  $V_{CC}$  or GND.

### 11. Electrical Characteristics

#### 11.1. DC Characteristics (Unless otherwise specified, $T_a = 25\text{ }^\circ\text{C}$ )

Characteristics	Symbol	Test Condition	$V_{CC}$ (V)	Min	Typ.	Max	Unit
High-level input voltage	$V_{IH}$	—	2.0	1.5	—	—	V
			3.0	2.0	—	—	
			4.5	3.15	—	—	
			5.5	3.85	—	—	
Low-level input voltage	$V_{IL}$	—	2.0	—	—	0.5	V
			3.0	—	—	0.8	
			4.5	—	—	1.35	
			5.5	—	—	1.65	
ON-resistance	$R_{ON}$	$V_{IN} = V_{IH}$ or $V_{IL}$ $V_{I/O} = V_{CC}$ to GND $I_{I/O} = 2\text{ mA}$	2.3	—	200	—	$\Omega$
			3.0	—	45	86	
			4.5	—	24	37	
		$V_{IN} = V_{IH}$ or $V_{IL}$ $V_{I/O} = V_{CC}$ or GND $I_{I/O} = 2\text{ mA}$	2.3	—	28	73	
			3.0	—	22	38	
			4.5	—	17	27	
Difference of ON-resistance between switches	$\Delta R_{ON}$	$V_{IN} = V_{IH}$ or $V_{IL}$ $V_{I/O} = V_{CC}$ to GND $I_{I/O} = 2\text{ mA}$	2.3	—	10	25	$\Omega$
			3.0	—	5	15	
			4.5	—	5	13	
Input/Output leakage current (Switch OFF)	$I_{OFF}$	$V_{OS} = V_{CC}$ or GND $V_{IS} = \text{GND}$ to $V_{CC}$ $V_{IN} = V_{IH}$ or $V_{IL}$	5.5	—	—	$\pm 0.1$	$\mu\text{A}$
Input/Output leakage current (Switch ON, Output OPEN)	$I_{I/O}$	$V_{OS} = V_{CC}$ or GND $V_{IN} = V_{IH}$ or $V_{IL}$	5.5	—	—	$\pm 0.1$	$\mu\text{A}$
Control input leakage current	$I_{IN}$	$V_{IN} = V_{CC}$ or GND	5.5	—	—	$\pm 0.1$	$\mu\text{A}$
Quiescent supply current	$I_{CC}$	$V_{IN} = V_{CC}$ or GND	5.5	—	—	2.0	$\mu\text{A}$

### 11.2. DC Characteristics (Unless otherwise specified, $T_a = -40$ to $85$ °C)

Characteristics	Symbol	Test Condition	$V_{CC}$ (V)	Min	Max	Unit
High-level input voltage	$V_{IH}$	—	2.0	1.5	—	V
			3.0	2.0	—	
			4.5	3.15	—	
			5.5	3.85	—	
Low-level input voltage	$V_{IL}$	—	2.0	—	0.50	V
			3.0	—	0.8	
			4.5	—	1.35	
			5.5	—	1.65	
ON-resistance	$R_{ON}$	$V_{IN} = V_{IH}$ or $V_{IL}$ $V_{I/O} = V_{CC}$ to GND $I_{I/O} = 2$ mA	2.3	—	—	$\Omega$
			3.0	—	108	
			4.5	—	46	
		$V_{IN} = V_{IH}$ or $V_{IL}$ $V_{I/O} = V_{CC}$ or GND $I_{I/O} = 2$ mA	2.3	—	84	
			3.0	—	44	
			4.5	—	31	
Difference of ON-resistance between switches	$\Delta R_{ON}$	$V_{IN} = V_{IH}$ or $V_{IL}$ $V_{I/O} = V_{CC}$ to GND $I_{I/O} = 2$ mA	2.3	—	35	$\Omega$
			3.0	—	20	
			4.5	—	18	
Input/Output leakage current (Switch OFF)	$I_{OFF}$	$V_{OS} = V_{CC}$ or GND $V_{IS} =$ GND to $V_{CC}$ $V_{IN} = V_{IH}$ or $V_{IL}$	5.5	—	$\pm 1.0$	$\mu A$
Input/Output leakage current (Switch ON, Output OPEN)	$I_{I/O}$	$V_{OS} = V_{CC}$ or GND $V_{IN} = V_{IH}$ or $V_{IL}$	5.5	—	$\pm 1.0$	$\mu A$
Control input leakage current	$I_{IN}$	$V_{IN} = V_{CC}$ or GND	5.5	—	$\pm 1.0$	$\mu A$
Quiescent supply current	$I_{CC}$	$V_{IN} = V_{CC}$ or GND	5.5	—	20.0	$\mu A$

### 11.3. DC Characteristics (Unless otherwise specified, $T_a = -40$ to $125$ °C)

Characteristics	Symbol	Test Condition	$V_{CC}$ (V)	Min	Max	Unit
High-level input voltage	$V_{IH}$	—	2.0	1.5	—	V
			3.0	2.0	—	
			4.5	3.15	—	
			5.5	3.85	—	
Low-level input voltage	$V_{IL}$	—	2.0	—	0.5	V
			3.0	—	0.8	
			4.5	—	1.35	
			5.5	—	1.65	
ON-resistance	$R_{ON}$	$V_{IN} = V_{IH}$ or $V_{IL}$ $V_{I/O} = V_{CC}$ to GND $I_{I/O} = 2$ mA	2.3	—	—	$\Omega$
			3.0	—	125	
			4.5	—	54	
		$V_{IN} = V_{IH}$ or $V_{IL}$ $V_{I/O} = V_{CC}$ or GND $I_{I/O} = 2$ mA	2.3	—	105	
			3.0	—	55	
			4.5	—	39	
Difference of ON-resistance between switches	$\Delta R_{ON}$	$V_{IN} = V_{IH}$ or $V_{IL}$ $V_{I/O} = V_{CC}$ to GND $I_{I/O} = 2$ mA	2.3	—	45	$\Omega$
			3.0	—	25	
			4.5	—	23	
Input/Output leakage current (Switch OFF)	$I_{OFF}$	$V_{OS} = V_{CC}$ or GND $V_{IS} = GND$ to $V_{CC}$ $V_{IN} = V_{IH}$ or $V_{IL}$	5.5	—	$\pm 4.0$	$\mu A$
Input/Output leakage current (Switch ON, Output OPEN)	$I_{I/O}$	$V_{OS} = V_{CC}$ or GND $V_{IN} = V_{IH}$ or $V_{IL}$	5.5	—	$\pm 4.0$	$\mu A$
Control input leakage current	$I_{IN}$	$V_{IN} = V_{CC}$ or GND	5.5	—	$\pm 2.0$	$\mu A$
Quiescent supply current	$I_{CC}$	$V_{IN} = V_{CC}$ or GND	5.5	—	40.0	$\mu A$

### 11.4. AC Characteristics (Unless otherwise specified, $T_a = 25\text{ }^\circ\text{C}$ , Input: $t_r = t_f = 3\text{ ns}$ )

Characteristics	Part Number	Symbol	Test Condition	$V_{CC}$ (V)	$C_L$ (pF)	Min	Typ.	Max	Unit	
Phase difference between input to output		$\phi_{I/O}$		$2.5 \pm 0.2$	15	—	1.2	10	ns	
					50	—	2.6	12		
				$3.3 \pm 0.3$	15	—	0.8	6		
					50	—	1.5	9		
				$5.0 \pm 0.5$	15	—	0.3	4		
					50	—	0.6	6		
Output enable time		$t_{PZL}, t_{PZH}$	$R_L = 1\text{ k}\Omega$ Figure 1	$2.5 \pm 0.2$	15	—	3.3	15	ns	
					50	—	4.2	25		
				$3.3 \pm 0.3$	15	—	2.3	11		
					50	—	3.0	18		
				$5.0 \pm 0.5$	15	—	1.6	7		
					50	—	2.1	12		
Output disable time		$t_{PLZ}, t_{PHZ}$	$R_L = 1\text{ k}\Omega$ Figure 1	$2.5 \pm 0.2$	15	—	6	15	ns	
					50	—	9.6	25		
				$3.3 \pm 0.3$	15	—	4.5	11		
					50	—	7.2	18		
				$5.0 \pm 0.5$	15	—	3.2	7		
					50	—	5.1	12		
Control input capacitance		$C_{IN}$	All types	—	—	—	2	—	pF	
Common terminal capacitance	74VHC4051AFT	$C_{IS}$	Figure 2	—	—	—	23.4	—	pF	
	74VHC4052AFT						—	13.1		—
	74VHC4053AFT						—	8.2		—
Switch terminal capacitance	74VHC4051AFT	$C_{OS}$	Figure 2	—	—	—	5.7	—	pF	
	74VHC4052AFT						—	5.6		—
	74VHC4053AFT						—	5.6		—
Feedthrough capacitance	74VHC4051AFT	$C_{IOS}$	Figure 2	—	—	—	0.5	—	pF	
	74VHC4052AFT						—	0.5		—
	74VHC4053AFT						—	0.5		—
Power dissipation capacitance	74VHC4051AFT	$C_{PD}$	Figure 2 (Note 1)	—	—	—	15	—	pF	
	74VHC4052AFT						—	24		—
	74VHC4053AFT						—	12		—

Note 1:  $C_{PD}$  is defined as the value of the internal equivalent capacitance which is calculated from the operating current consumption without load. Average operating current can be obtained by the equation.

$$I_{CC(opr)} = C_{PD} \times V_{CC} \times f_{IN} + I_{CC}$$

### 11.5. AC Characteristics

(Unless otherwise specified,  $T_a = -40$  to  $85$  °C, Input:  $t_r = t_f = 3$  ns)

Characteristics	Symbol	Test Condition	$V_{CC}$ (V)	$C_L$ (pF)	Min	Max	Unit				
Phase difference between input to output	$\phi_{I/O}$		$2.5 \pm 0.2$	15	—	16	ns				
				50	—	18					
			$3.3 \pm 0.3$	15	—	10					
				50	—	12					
			$5.0 \pm 0.5$	15	—	7					
				50	—	8					
			Output enable time	$t_{PZL}, t_{PZH}$	$R_L = 1$ k $\Omega$ Figure 1	$2.5 \pm 0.2$		15	—	20	ns
								50	—	32	
$3.3 \pm 0.3$	15	—				15					
	50	—				22					
$5.0 \pm 0.5$	15	—				10					
	50	—				16					
Output disable time	$t_{PLZ}, t_{PHZ}$	$R_L = 1$ k $\Omega$ Figure 1				$2.5 \pm 0.2$	15	—	23	ns	
							50	—	32		
			$3.3 \pm 0.3$	15	—	15					
				50	—	22					
			$5.0 \pm 0.5$	15	—	10					
				50	—	16					
			Control input capacitance	$C_{IN}$	—	—	—	10	pF		

### 11.6. AC Characteristics

(Unless otherwise specified,  $T_a = -40$  to  $125$  °C, Input:  $t_r = t_f = 3$  ns)

Characteristics	Symbol	Test Condition	$V_{CC}$ (V)	$C_L$ (pF)	Min	Max	Unit				
Phase difference between input to output	$\phi_{I/O}$		$2.5 \pm 0.2$	15	—	20	ns				
				50	—	22					
			$3.3 \pm 0.3$	15	—	13					
				50	—	14					
			$5.0 \pm 0.5$	15	—	9					
				50	—	9.5					
			Output enable time	$t_{PZL}, t_{PZH}$	$R_L = 1$ k $\Omega$ Figure 1	$2.5 \pm 0.2$		15	—	23.5	ns
								50	—	37	
$3.3 \pm 0.3$	15	—				18					
	50	—				25					
$5.0 \pm 0.5$	15	—				12					
	50	—				19					
Output disable time	$t_{PLZ}, t_{PHZ}$	$R_L = 1$ k $\Omega$ Figure 1				$2.5 \pm 0.2$	15	—	28.5	ns	
							50	—	37		
			$3.3 \pm 0.3$	15	—	18					
				50	—	25					
			$5.0 \pm 0.5$	15	—	12					
				50	—	19					
			Control input capacitance	$C_{IN}$	—	—	—	10	pF		

### 11.7. Analog Switch Characteristics ( $T_a = 25\text{ }^\circ\text{C}$ ) (Note)

Characteristics	Part Number	Symbol	Test Condition	$V_{CC}$ (V)	Typ.	Unit	
Sine Wave Distortion		THD	$R_L = 10\text{ k}\Omega$ , $C_L = 50\text{ pF}$ $f_{IN} = 1\text{ kHz}$	$V_{IN} = 2.0\text{ V}_{p-p}$	3.0	0.1	%
				$V_{IN} = 4.0\text{ V}_{p-p}$	4.5	0.03	
Maximum frequency response	74VHC4051AFT	$f_{MAX(I/O)}$	$V_{IN}$ is centered at $(V_{CC}/2)$ . Adjust input for 0 dBm. Increase $f_{IN}$ frequency until dB meter reads -3 dB. $R_L = 50\text{ }\Omega$ , $C_L = 10\text{ pF}$ , sine wave Figure 3	3.0	150	MHz	
	74VHC4052AFT				200		
	74VHC4053AFT			240			
	74VHC4051AFT			4.5	180		
	74VHC4052AFT				230		
	74VHC4053AFT				280		
Feed through attenuation (switch OFF)		FTH	$V_{IN}$ is centered at $(V_{CC}/2)$ . Adjust input for 0 dBm. $R_L = 600\text{ }\Omega$ , $C_L = 50\text{ pF}$ , $f_{IN} = 1\text{ MHz}$ , sine wave Figure 4	3.0	-45	dB	
				4.5	-45		
				3.0	-65		
				4.5	-65		
Crosstalk (control input to signal output)		$X_{talk}$	$R_L = 600\text{ }\Omega$ , $C_L = 50\text{ pF}$ , $f_{IN} = 1\text{ MHz}$ , square wave ( $t_r = t_f = 6\text{ ns}$ ) Figure 5	3.0	60	mV	
				4.5	100		
Crosstalk (between any switches)		$X_{talk}$	$V_{IN}$ is centered at $(V_{CC}/2)$ . Adjust input for 0 dBm. $R_L = 600\text{ }\Omega$ , $C_L = 50\text{ pF}$ , $f_{IN} = 1\text{ MHz}$ , sine wave Figure 6	3.0	-45	dB	
				4.5	-45		

Note: These characteristics are determined by design of devices.

### 12. AC Test Circuit

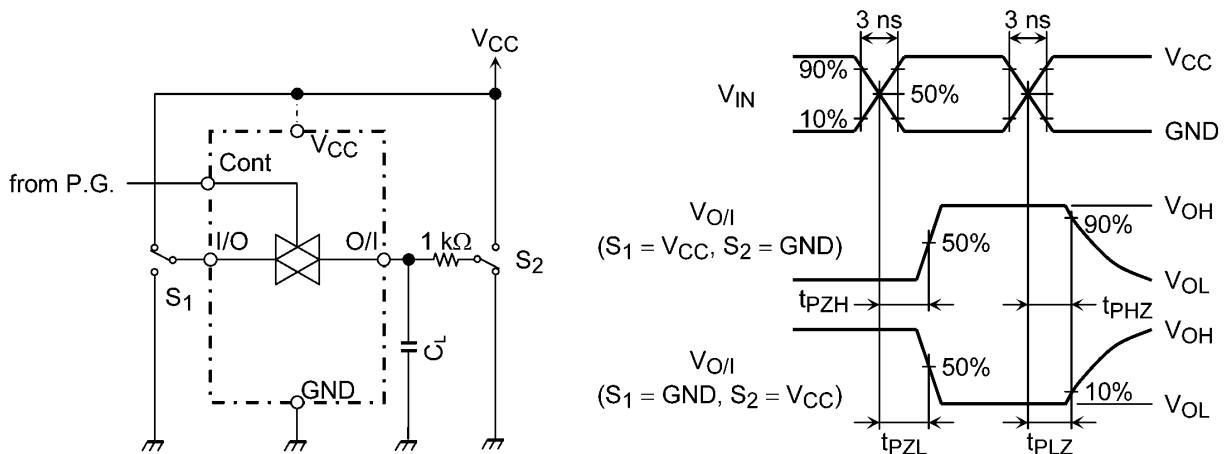

Cont : Control Inputs A or B or C or INH (C: Except VHC4052A)

P.G. : Pulse generator

**Figure 1**  $t_{PLZ}$ ,  $t_{PHZ}$ ,  $t_{PZL}$ ,  $t_{PZH}$

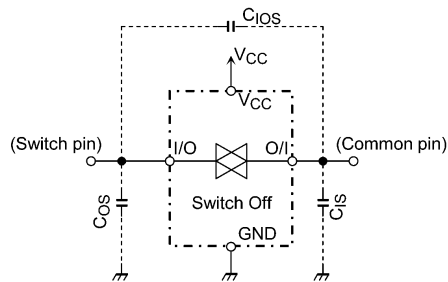

**Figure 2**  $C_{1OS}$ ,  $C_{1S}$ ,  $C_{2S}$

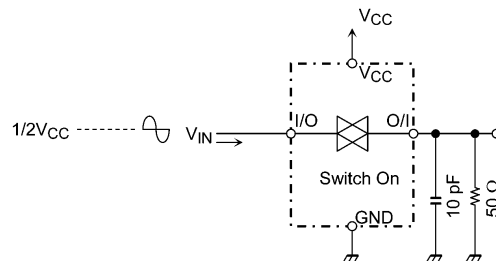

**Figure 3** Frequency Response

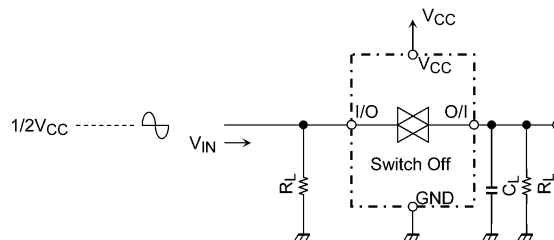

**Figure 4** Feedthrough Attenuation

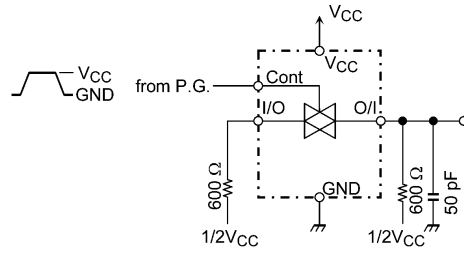

Cont : Control Inputs A or B or C or INH ( C:Except VHC4052A )

P.G. : Pulse generator

**Figure 5 Cross Talk (control input to output signal)**

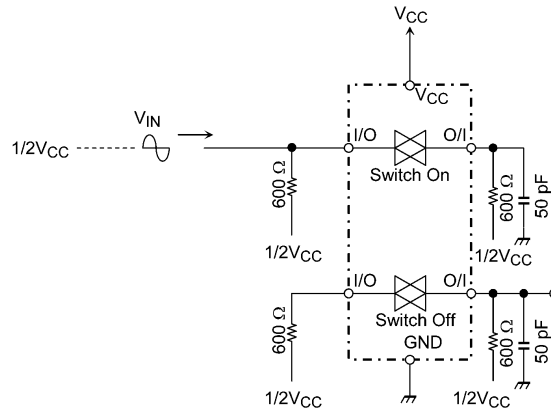

**Figure 6 Cross Talk (between any two switches)**

## Package Dimensions

Unit: mm

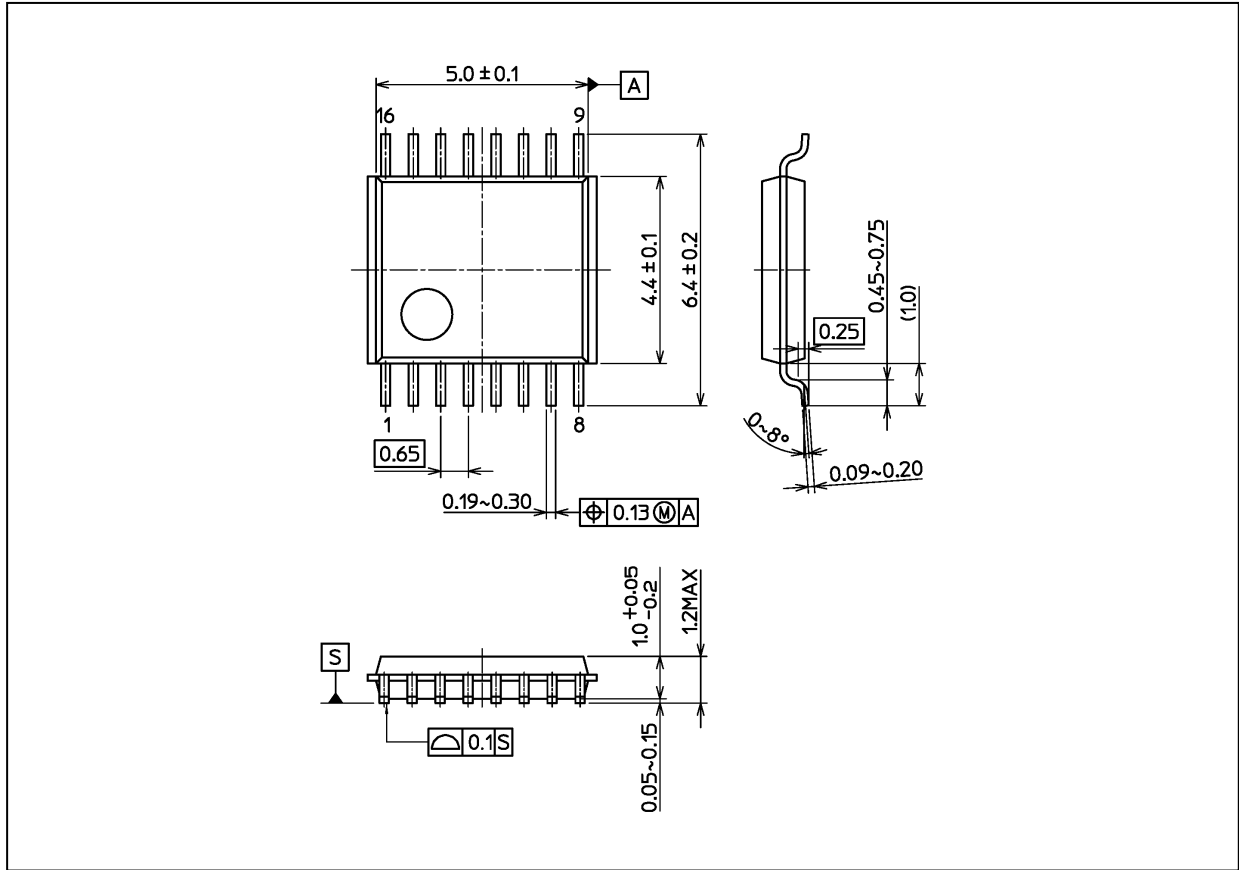

Weight: 0.055 g (typ.)

Package Name(s)
Nickname: TSSOP16B

### RESTRICTIONS ON PRODUCT USE

Toshiba Corporation and its subsidiaries and affiliates are collectively referred to as "TOSHIBA".

Hardware, software and systems described in this document are collectively referred to as "Product".

- TOSHIBA reserves the right to make changes to the information in this document and related Product without notice.
- This document and any information herein may not be reproduced without prior written permission from TOSHIBA. Even with TOSHIBA's written permission, reproduction is permissible only if reproduction is without alteration/omission.
- Though TOSHIBA works continually to improve Product's quality and reliability, Product can malfunction or fail. Customers are responsible for complying with safety standards and for providing adequate designs and safeguards for their hardware, software and systems which minimize risk and avoid situations in which a malfunction or failure of Product could cause loss of human life, bodily injury or damage to property, including data loss or corruption. Before customers use the Product, create designs including the Product, or incorporate the Product into their own applications, customers must also refer to and comply with (a) the latest versions of all relevant TOSHIBA information, including without limitation, this document, the specifications, the data sheets and application notes for Product and the precautions and conditions set forth in the "TOSHIBA Semiconductor Reliability Handbook" and (b) the instructions for the application with which the Product will be used with or for. Customers are solely responsible for all aspects of their own product design or applications, including but not limited to (a) determining the appropriateness of the use of this Product in such design or applications; (b) evaluating and determining the applicability of any information contained in this document, or in charts, diagrams, programs, algorithms, sample application circuits, or any other referenced documents; and (c) validating all operating parameters for such designs and applications.  
**TOSHIBA ASSUMES NO LIABILITY FOR CUSTOMERS' PRODUCT DESIGN OR APPLICATIONS.**

- **PRODUCT IS NEITHER INTENDED NOR WARRANTED FOR USE IN EQUIPMENTS OR SYSTEMS THAT REQUIRE EXTRAORDINARILY HIGH LEVELS OF QUALITY AND/OR RELIABILITY, AND/OR A MALFUNCTION OR FAILURE OF WHICH MAY CAUSE LOSS OF HUMAN LIFE, BODILY INJURY, SERIOUS PROPERTY DAMAGE AND/OR SERIOUS PUBLIC IMPACT ("UNINTENDED USE").**

Except for specific applications as expressly stated in this document, Unintended Use includes, without limitation, equipment used in nuclear facilities, equipment used in the aerospace industry, lifesaving and/or life supporting medical equipment, equipment used for automobiles, trains, ships and other transportation, traffic signaling equipment, equipment used to control combustions or explosions, safety devices, elevators and escalators, and devices related to power plant.

**IF YOU USE PRODUCT FOR UNINTENDED USE, TOSHIBA ASSUMES NO LIABILITY FOR PRODUCT.**

For details, please contact your TOSHIBA sales representative or contact us via our website.

- Do not disassemble, analyze, reverse-engineer, alter, modify, translate or copy Product, whether in whole or in part.
- Product shall not be used for or incorporated into any products or systems whose manufacture, use, or sale is prohibited under any applicable laws or regulations.
- The information contained herein is presented only as guidance for Product use. No responsibility is assumed by TOSHIBA for any infringement of patents or any other intellectual property rights of third parties that may result from the use of Product. No license to any intellectual property right is granted by this document, whether express or implied, by estoppel or otherwise.
- **ABSENT A WRITTEN SIGNED AGREEMENT, EXCEPT AS PROVIDED IN THE RELEVANT TERMS AND CONDITIONS OF SALE FOR PRODUCT, AND TO THE MAXIMUM EXTENT ALLOWABLE BY LAW, TOSHIBA (1) ASSUMES NO LIABILITY WHATSOEVER, INCLUDING WITHOUT LIMITATION, INDIRECT, CONSEQUENTIAL, SPECIAL, OR INCIDENTAL DAMAGES OR LOSS, INCLUDING WITHOUT LIMITATION, LOSS OF PROFITS, LOSS OF OPPORTUNITIES, BUSINESS INTERRUPTION AND LOSS OF DATA, AND (2) DISCLAIMS ANY AND ALL EXPRESS OR IMPLIED WARRANTIES AND CONDITIONS RELATED TO SALE, USE OF PRODUCT, OR INFORMATION, INCLUDING WARRANTIES OR CONDITIONS OF MERCHANTABILITY, FITNESS FOR A PARTICULAR PURPOSE, ACCURACY OF INFORMATION, OR NONINFRINGEMENT.**
- Do not use or otherwise make available Product or related software or technology for any military purposes, including without limitation, for the design, development, use, stockpiling or manufacturing of nuclear, chemical, or biological weapons or missile technology products (mass destruction weapons). Product and related software and technology may be controlled under the applicable export laws and regulations including, without limitation, the Japanese Foreign Exchange and Foreign Trade Law and the U.S. Export Administration Regulations. Export and re-export of Product or related software or technology are strictly prohibited except in compliance with all applicable export laws and regulations.
- Please contact your TOSHIBA sales representative for details as to environmental matters such as the RoHS compatibility of Product. Please use Product in compliance with all applicable laws and regulations that regulate the inclusion or use of controlled substances, including without limitation, the EU RoHS Directive. **TOSHIBA ASSUMES NO LIABILITY FOR DAMAGES OR LOSSES OCCURRING AS A RESULT OF NONCOMPLIANCE WITH APPLICABLE LAWS AND REGULATIONS.**

## Looking for pricing, stock, or lifecycle information?

Click below to explore more details on WIN SOURCE:

- [View 74VHC4051AFT on WIN SOURCE](#)
- [Toshiba Semiconductor and Storage Information](#)

## Optimize Your Supply Chain with WIN SOURCE Solutions

- ✓ Global Sourcing Solution
- ✓ Obsolete Management
- ✓ Cost Control Management
- ✓ Shortage Management
- ✓ Alternative Solution
- ✓ Excess Inventory Management