



**THE DATASHEET OF
LM3407MYX/NOPB**



LM3407 350-mA, Constant Current Output Floating Buck Switching Converter for High-Power LEDs

1 Features

- Input Operating Range 4.5 V to 30 V
- Output Voltage Range: 0.1 V_{IN} to 0.9 V_{IN}
- Accurate Constant Current Output
- Independent Device Enable (CMOS Compatible) and PWM Dimming Control
- Converter Switching Frequency Adjustable From 300 kHz to 1 MHz
- No External Control Loop Compensation Required
- Supports Ceramic and Low ESR Output Capacitors
- Input Undervoltage Lockout (UVLO)
- Thermal Shutdown Protection
- MSOP-8 PowerPAD Package

2 Applications

- LED Drivers
- Constant Current Sources
- Automotive Lighting
- General Illumination
- Industrial Lighting

3 Description

The LM3407 device is a constant current output floating buck switching converter designed to provide constant current to high-power LEDs. The device is ideal for automotive, industrial, and general lighting applications. The LM3407 has an integrated power N-channel MOSFET that makes the application solution compact and simple to implement. An external 1% thick-film resistor allows the converter output voltage to adjust as needed to deliver constant current within 10% accuracy to a serially connected LED string of varying number and type. Converter switching frequency is adjustable from 300 kHz to 1 MHz. The LM3407 features a dimming input to enable LED brightness control by Pulse Width Modulation (PWM). Additionally, a separate enable pin allows for low-power shutdown. An exposed pad MSOP-8 package provides excellent heat dissipation and thermal performance. Input UVLO and output open-circuit protection ensure a robust LED driver solution.

Device Information⁽¹⁾

PART NUMBER	PACKAGE	BODY SIZE (NOM)
LM3407	MSOP-PowerPAD (8)	3.00 mm x 3.00 mm

(1) For all available packages, see the orderable addendum at the end of the data sheet.

Simplified Application Schematic

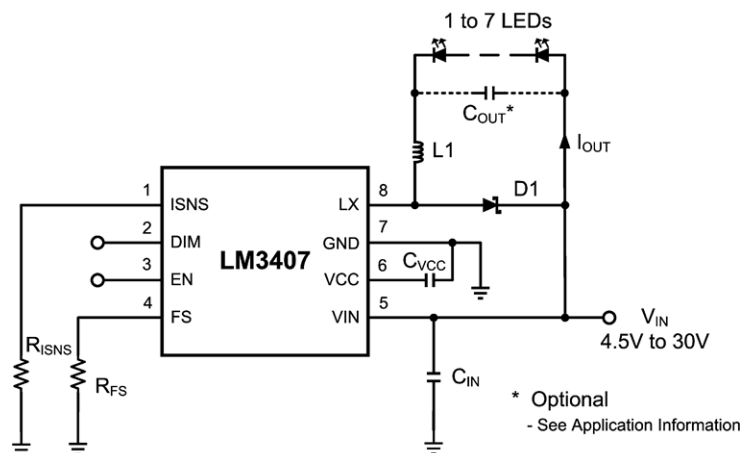

Copyright © 2016, Texas Instruments Incorporated



Table of Contents

1 Features	1	7.4 Device Functional Modes.....	13
2 Applications	1	8 Application and Implementation	14
3 Description	1	8.1 Application Information.....	14
4 Revision History	2	8.2 Typical Applications	17
5 Pin Configuration and Functions	3	9 Power Supply Recommendations	20
6 Specifications	4	10 Layout	20
6.1 Absolute Maximum Ratings	4	10.1 Layout Guidelines	20
6.2 ESD Ratings.....	4	10.2 Layout Example	20
6.3 Recommended Operating Conditions.....	4	11 Device and Documentation Support	21
6.4 Thermal Information	4	11.1 Documentation Support	21
6.5 Electrical Characteristics.....	5	11.2 Receiving Notification of Documentation Updates	21
6.6 Typical Characteristics	6	11.3 Community Resources.....	21
7 Detailed Description	9	11.4 Trademarks	21
7.1 Overview	9	11.5 Electrostatic Discharge Caution.....	21
7.2 Functional Block Diagram	9	11.6 Glossary	21
7.3 Feature Description.....	10	12 Mechanical, Packaging, and Orderable Information	21

4 Revision History

NOTE: Page numbers for previous revisions may differ from page numbers in the current version.

Changes from Revision B (May 2013) to Revision C	Page
<ul style="list-style-type: none"> Added <i>ESD Ratings</i> table, <i>Thermal Information</i> table, <i>Feature Description</i> section, <i>Device Functional Modes</i>, <i>Application and Implementation</i> section, <i>Power Supply Recommendations</i> section, <i>Layout</i> section, <i>Device and Documentation Support</i> section, and <i>Mechanical, Packaging, and Orderable Information</i> section..... 	1
<ul style="list-style-type: none"> Changed $R_{\theta JA}$ for DGN package from 50°C/W to 55.6°C/W 	4

Changes from Revision A (January 2009) to Revision B	Page
<ul style="list-style-type: none"> Changed layout of National Semiconductor Data Sheet to TI format. 	20

5 Pin Configuration and Functions

**DGN Package
8-Pin MSOP
Top View**

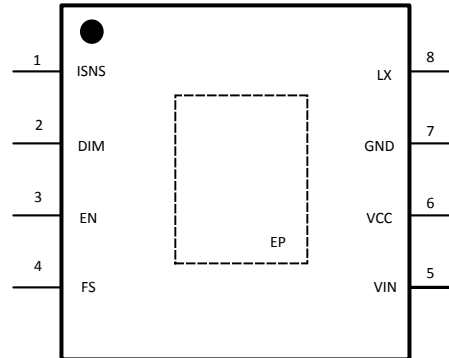

Pin Functions

PIN		I/O	DESCRIPTION
NO.	NAME		
1	ISNS	I	Connect resistor R_{ISNS} from this pin to ground for LED current sensing. The current sensing resistor should be placed close to this pin.
2	DIM	I	PWM Dimming Control Pin. Applying a logic level PWM signal to this pin controls the intended brightness of the LED string.
3	EN	I	Applying logic high to this pin or leaving it open enables the switcher. When pulled low the switcher is disabled and will enter low power shutdown mode.
4	FS	I	Switching Frequency Setting Pin. Connect resistor R_{FS} from this pin to ground to set the switching frequency.
5	VIN	I	Input Voltage Pin. The input voltage should be in the range of 4.5 V to 30 V
6	VCC	O	Internal Regulator Output Pin. This pin should be bypassed to ground by a ceramic capacitor with a minimum value of 1 μ F.
7	GND	—	This pin should be connected to the system ground.
8	LX	O	Drain of N-MOSFET Switch. Connect this pin to the output inductor and anode of the Schottky diode.
EP	EP	—	Thermal Pad (Power Ground). Used to dissipate heat from the package during operation. Must be electrically connected to GND external to the package.

6 Specifications

6.1 Absolute Maximum Ratings

over operating free-air temperature range (unless otherwise noted)⁽¹⁾

	MIN	MAX	UNIT
V _{IN} to GND	−0.3	36	V
V _{IN} to GND (transient)		42 (500 ms)	V
LX to GND	−0.3	36	V
LX to GND (transient)	−3 (2 ns)	42 (500 ms)	V
FS, ISNS, DIM, EN to GND	−0.3	7	V
Storage temperature, T _{stg}	−65	125	°C

- (1) Stresses beyond those listed under *Absolute Maximum Ratings* may cause permanent damage to the device. These are stress ratings only, which do not imply functional operation of the device at these or any other conditions beyond those indicated under *Recommended Operating Conditions*. Exposure to absolute-maximum-rated conditions for extended periods may affect device reliability.

6.2 ESD Ratings

		VALUE	UNIT
V _(ESD) Electrostatic discharge	Human-body model (HBM), per ANSI/ESDA/JEDEC JS-001 ⁽¹⁾	±2000	V
	Charged-device model (CDM), per JEDEC specification JESD22-C101 ⁽²⁾	±750	

- (1) JEDEC document JEP155 states that 500-V HBM allows safe manufacturing with a standard ESD control process.
 (2) JEDEC document JEP157 states that 250-V CDM allows safe manufacturing with a standard ESD control process.

6.3 Recommended Operating Conditions

over operating free-air temperature range (unless otherwise noted)

	MIN	MAX	UNIT
V _{IN}	4.5	30	V
Junction temperature	−40	125	°C

6.4 Thermal Information

THERMAL METRIC ⁽¹⁾		LM3407	UNIT
		DGN (MSOP)	
		8 PINS	
R _{θJA}	Junction-to-ambient thermal resistance	55.6	°C/W
R _{θJC(top)}	Junction-to-case (top) thermal resistance	50.7	°C/W
R _{θJB}	Junction-to-board thermal resistance	28.8	°C/W
ψ _{JT}	Junction-to-top characterization parameter	1.6	°C/W
ψ _{JB}	Junction-to-board characterization parameter	28.6	°C/W
R _{θJC(bot)}	Junction-to-case (bottom) thermal resistance	4.9	°C/W

- (1) For more information about traditional and new thermal metrics, see the [Semiconductor and IC Package Thermal Metrics](#) application report.

6.5 Electrical Characteristics

MIN and MAX limits apply for $T_J = -40^\circ\text{C}$ to $+125^\circ\text{C}$ unless specified otherwise. $V_{IN} = 12\text{ V}$ unless otherwise indicated.

PARAMETER		TEST CONDITIONS	MIN ⁽¹⁾	TYP ⁽²⁾	MAX ⁽¹⁾	UNIT
SYSTEM PARAMETERS						
I_{IN}	Operating input current	$4.5\text{ V} \leq V_{IN} \leq 30\text{ V}$, LX = open, $V_{PWM} = V_{EN} = 5\text{ V}$	0.58	0.78	0.98	mA
I_Q	Quiescent Input current	$4.5\text{ V} \leq V_{IN} \leq 30\text{ V}$, $V_{PWM} = 0\text{ V}$, $V_{EN} = 5\text{ V}$	0.2	0.27	0.39	mA
I_{SHUT}	Shutdown input current	$V_{EN} = 0\text{ V}$	36	48	60	μA
V_{UVLO}	Input undervoltage lockout threshold	V_{IN} Rising		3.6	4.5	V
$V_{UVLO-HYS}$	UVLO hysteresis	V_{IN} Falling		200		mV
V_{EN_H}	EN Pin HIGH threshold	V_{EN} Rising		1.9	2.4	V
V_{EN_L}	EN Pin LOW threshold	V_{EN} Falling	1.3	1.75		V
V_{DIM_H}	DIM Pin HIGH threshold	V_{DIM} Rising		1.9	2.4	V
V_{DIM_L}	DIM Pin LOW threshold	V_{DIM} Falling	1.3	1.75		V
f_{SW}	Switching frequency	$R_T = 80\text{ k}\Omega$		500		kHz
		$R_T = 40\text{ k}\Omega$		1000		
t_{ON-MIN}	Minimum on-time			200		ns
T_{SD}	Thermal shutdown threshold			165		$^\circ\text{C}$
T_{SD-HYS}	Thermal shutdown hysteresis			25		
INTERNAL VOLTAGE REGULATOR						
V_{CC}	V_{CC} regulator output voltage ⁽³⁾	$V_{IN} = 12\text{ V}$		4.5		V
MAIN SWITCH						
$R_{DS(ON)}$	Main switch ON resistance	$I_{SINK} = 80\text{ mA}$		0.77	1.45	Ω
CONTROL LOOP						
A_{EA}	Error amp open loop gain			60		dB

- (1) All limits specified at room temperature (TYP) and at temperature extremes (MIN/MAX). All room temperature limits are 100% production tested. All limits at temperature extremes are specified through correlation using standard Statistical Quality Control (SQC) methods. All limits are used to calculate Average Outgoing Quality Level (AOQL).
- (2) Typical specification represent the most likely parametric norm at 25°C operation.
- (3) V_{CC} provides self bias for the internal gate drive and control circuits. Device thermal limitations limit external loading to the pin.

6.6 Typical Characteristics

All curves taken at $V_{IN} = 12\text{ V}$ with configuration in typical application for driving two power LEDs with $I_{LED} = 0.35\text{ A}$ shown in this data sheet and $T_A = 25^\circ\text{C}$, unless otherwise specified.

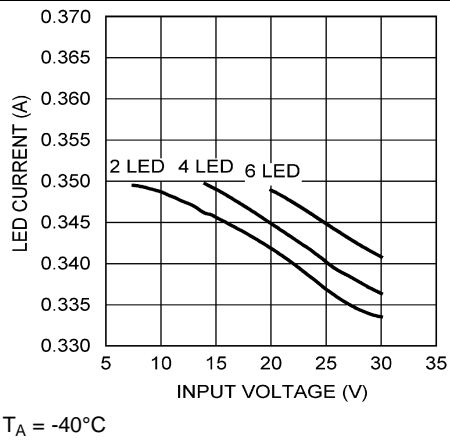

Figure 1. Output Current vs Input Voltage

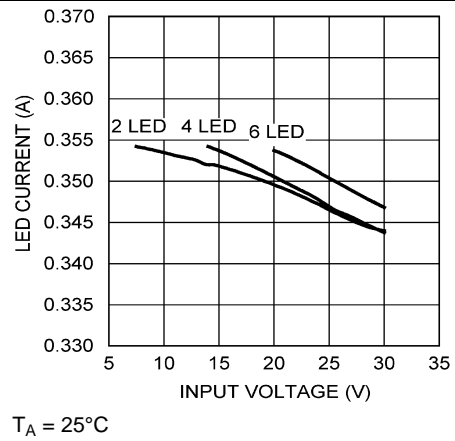

Figure 2. Output Current vs Input Voltage

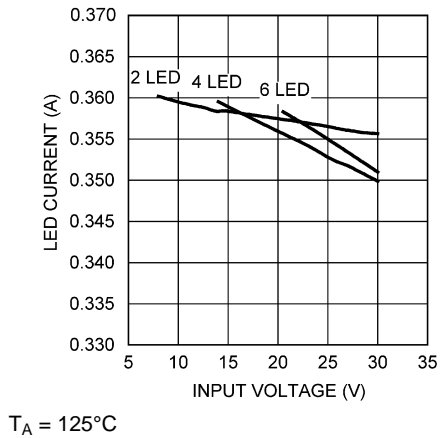

Figure 3. Output Current vs Input Voltage

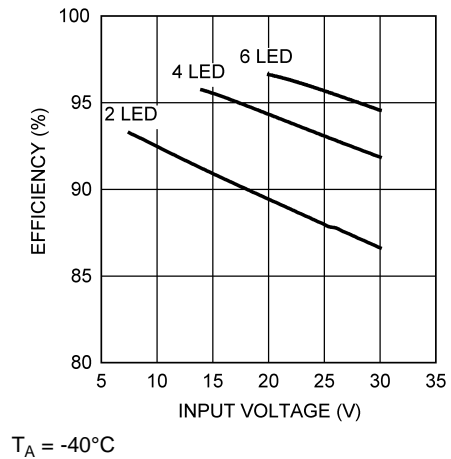

Figure 4. Efficiency vs Input Voltage

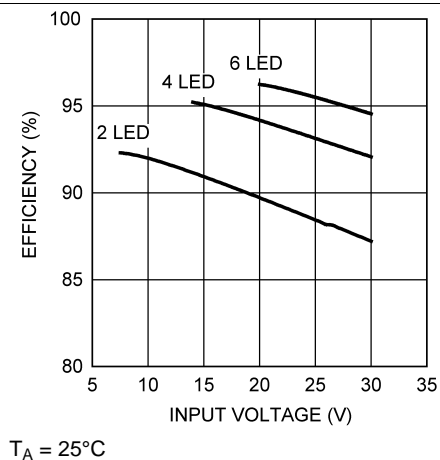

Figure 5. Efficiency vs Input Voltage

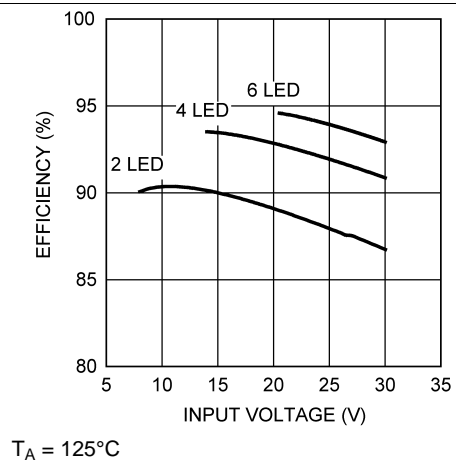

Figure 6. Efficiency vs Input Voltage

Typical Characteristics (continued)

All curves taken at $V_{IN} = 12\text{ V}$ with configuration in typical application for driving two power LEDs with $I_{LED} = 0.35\text{ A}$ shown in this data sheet and $T_A = 25^\circ\text{C}$, unless otherwise specified.

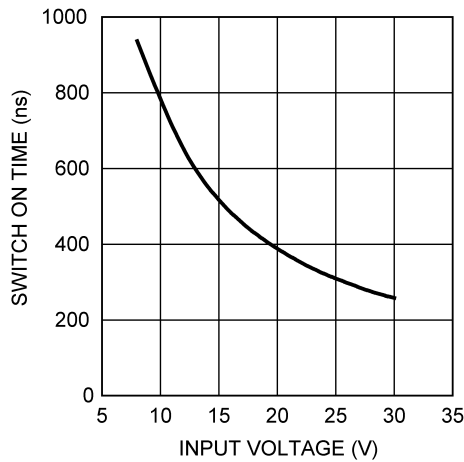

Figure 7. Switch On Time vs Input Voltage

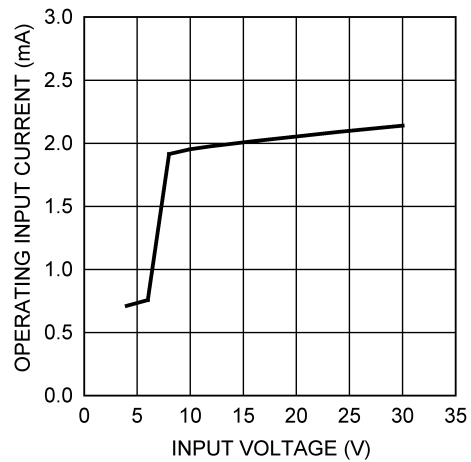

Figure 8. Operating Input Current vs Input Voltage

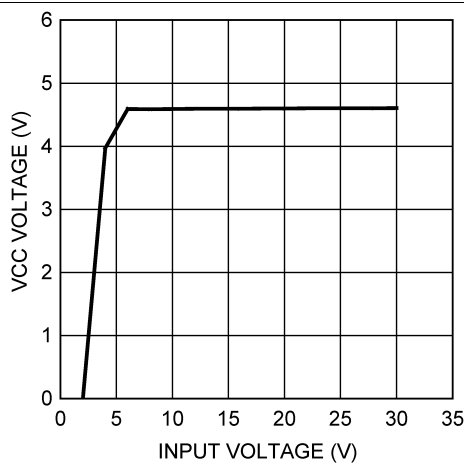

Figure 9. VCC Voltage vs Input Voltage

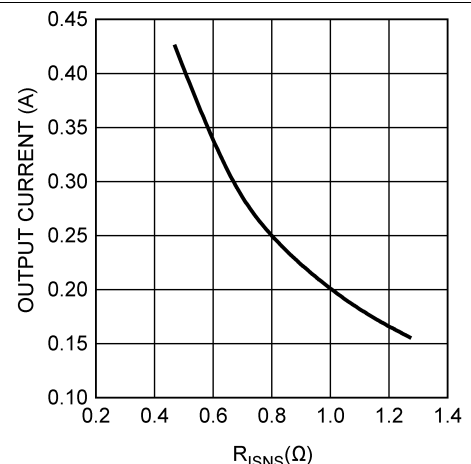

Figure 10. Output Current vs R_{ISNS}

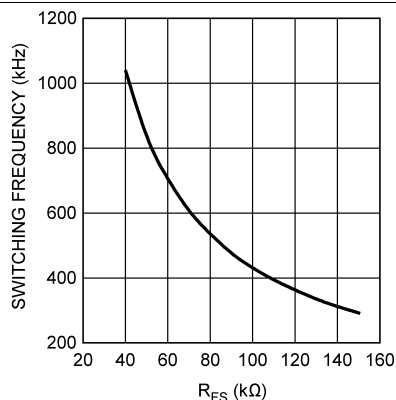

Figure 11. Switching Frequency vs R_{FS}

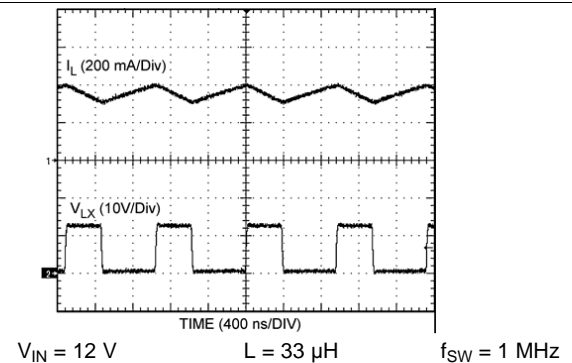
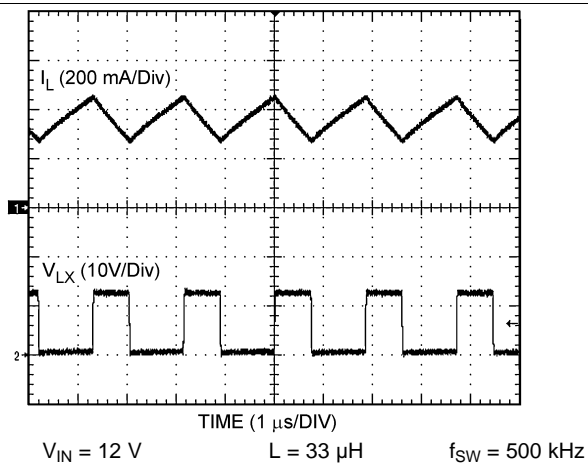
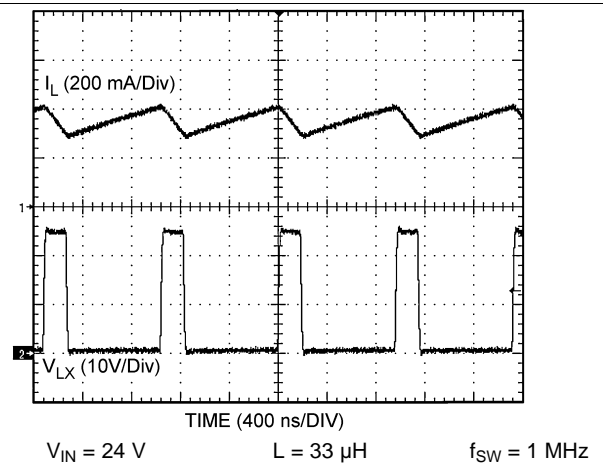
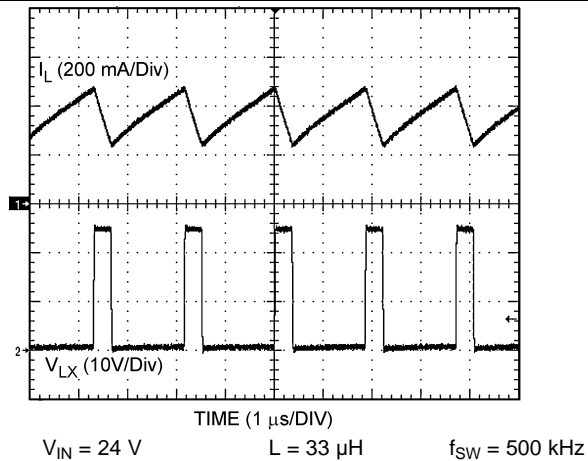
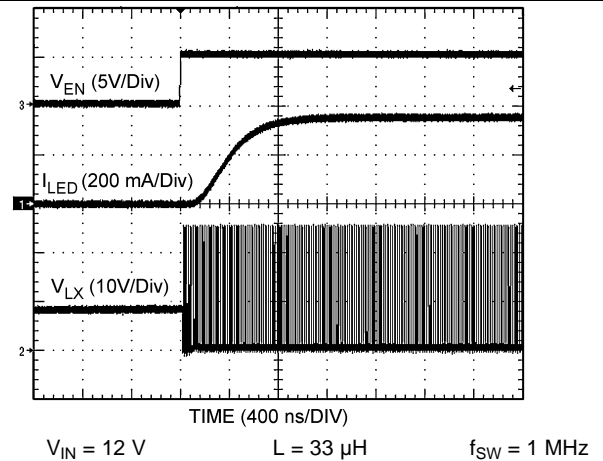
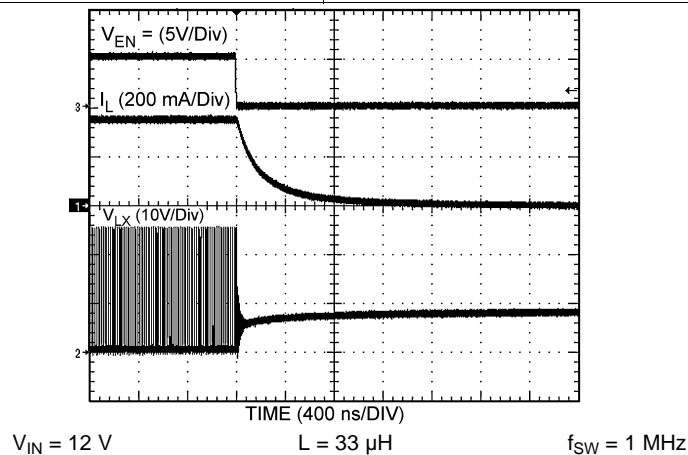

Figure 12. Continuous Mode Operation

Typical Characteristics (continued)

All curves taken at $V_{IN} = 12\text{ V}$ with configuration in typical application for driving two power LEDs with $I_{LED} = 0.35\text{ A}$ shown in this data sheet and $T_A = 25^\circ\text{C}$, unless otherwise specified.

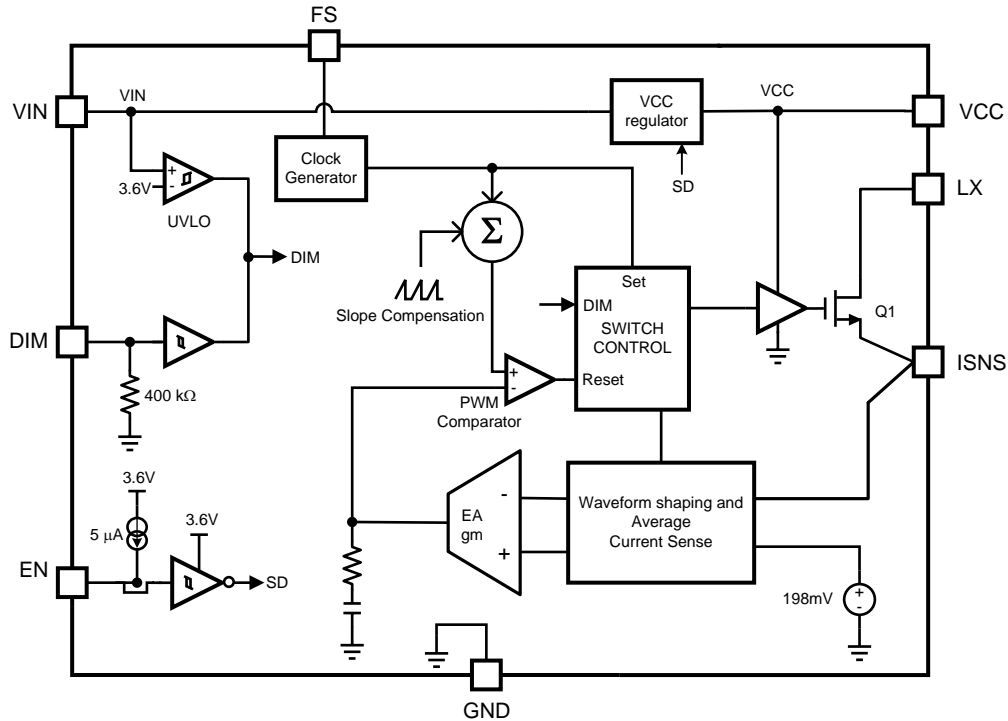

Figure 13. Continuous Mode Operation

Figure 14. Continuous Mode Operation

Figure 15. Continuous Mode Operation

Figure 16. DIM Pin Enable Transient

Figure 17. DIM Pin Disable Transient

7 Detailed Description

7.1 Overview

The LM3407 is a high power floating buck LED driver with a wide input voltage range. The device requires no loop compensation network. The integrated power N-MOSFET enables high-output power with up to 350-mA output current. The combination of Pulse Width Modulation (PWM), control architecture, and the proprietary Pulse Level Modulation (PLM) ensures accurate current regulation, good EMI performance, and provides high flexibility on inductor selection. High-speed dimming control input allows precision and high resolution brightness control for applications require fine brightness adjustment.

7.2 Functional Block Diagram



Copyright © 2016, Texas Instruments Incorporated

7.3 Feature Description

7.3.1 Floating Buck Switching Converter

The LM3407 is designed for floating buck configuration. Different from conventional buck converters, a low-side power N-MOSFET is used. The floating buck configuration simplifies the driver stage design and reduces the die size of the power MOSFET. Additionally, the connections of the power diode, inductor and output capacitor are switched to ground with a ground referenced power switch, Q1. The extraction of inductor current information can be easily realized by a simple current sensing resistor. These benefits combine to provide a high efficiency, low cost, and reliable solution for LED lighting applications.

The operation of the LM3407 constant current output floating buck converter is explained below. With the internal switch Q1 turned ON, current flows through the inductor L1 and the LED array. Energy is also stored in the magnetic field of the inductor during the ON cycle. The current flowing through R_{ISNS} during the ON cycle is monitored by the Average Current Sensing block. The switch will remain ON until the average inductor current equals $198 \text{ mV} / R_{ISNS}$. When the switch is turned OFF, the magnetic field starts to collapse and the polarity of the inductor voltage reverses. At the same time, the diode is forward biased and current flows through the LED, releasing the energy stored in the inductor to the output. True average output current is achieved as the switching cycle continuously repeats and the Average Current Sensing block controls the ON duty cycle. A constant current output floating buck converter only works in Continuous Conduction Mode (CCM); if the converter enters Discontinuous Conduction Mode (DCM) operation, the current regulation will deteriorate and the accuracy of LED current cannot be maintained. The operating waveforms for the typical application circuit are shown in [Figure 18](#).

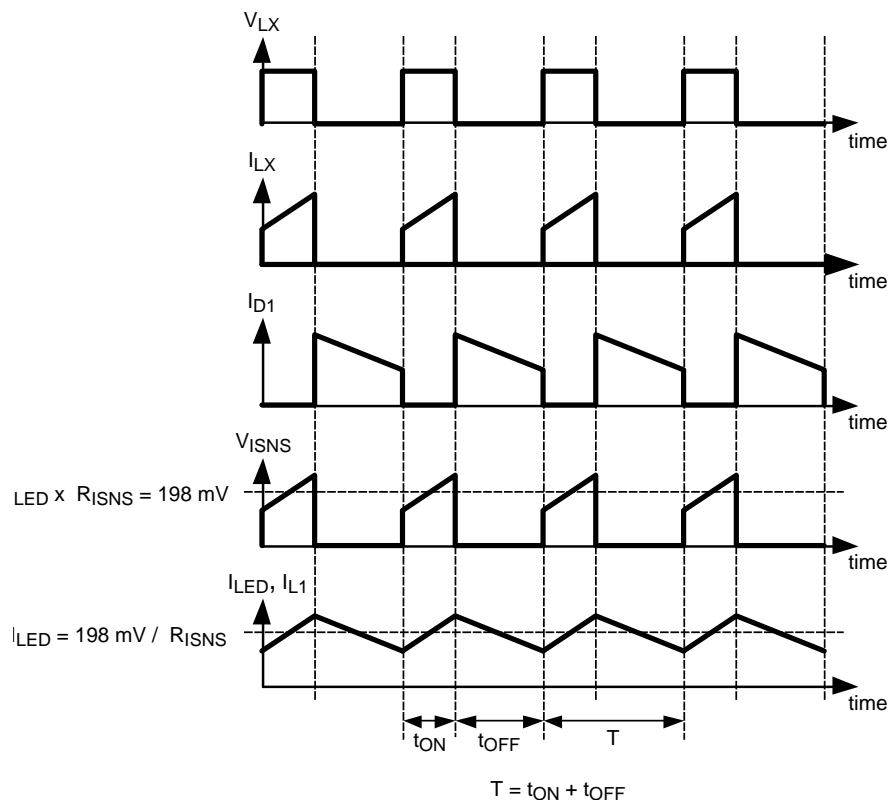

Figure 18. Operating Waveforms of a Floating Buck Converter

Feature Description (continued)

7.3.2 Pulse Level Modulation (PLM)

The LM3407 incorporates the innovative Pulse Level Modulation technique. With an external 1% thick film resistor connected to the ISNS pin, the converter output voltage can adjust automatically as needed to deliver constant current within 10% accuracy to a serially connected LED string of different number and type. Pulse Level Modulation is a novel method to provide precise constant current control with high efficiency. It allows the use of low side current sensing and facilitates true average output current regulation regardless of the input voltage and inductor value. Pulse Level Modulation can be treated as a process that transforms a trapezoidal pulse chain into a square pulse chain with an amplitude equal to the center of inductor current ramp. Figure 19 shows the waveform of the converter in steady state. In the figure, I_{L1} is the inductor current and I_{LX} is the switch current into the LX pin. V_{ISNS} is the voltage drop across the current sensing resistor R_{ISNS} . V_{MSL} is the center of the inductor current ramp and is a reference pulse that is synchronized and has an identical pulse width to V_{ISNS} .

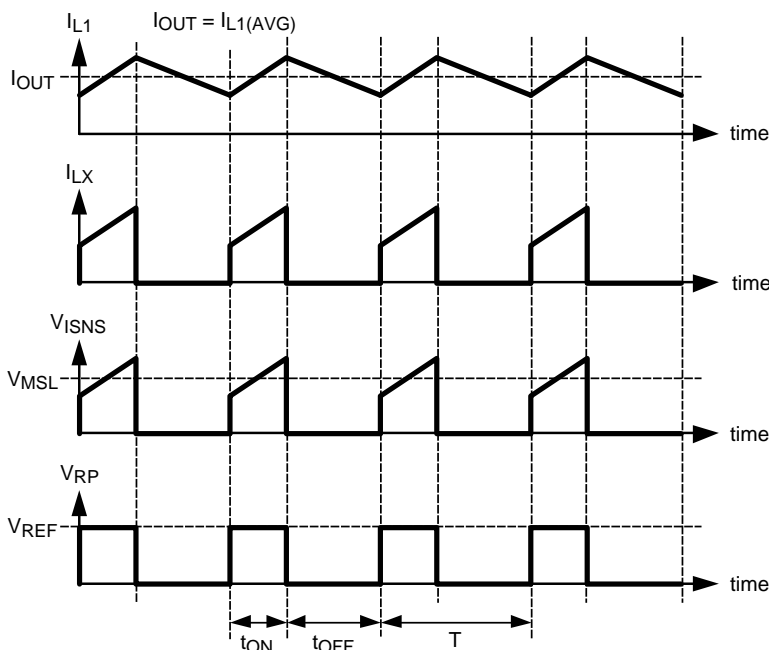

Figure 19. LM3407 Switching Waveforms

The switching frequency and duty ratio of the converter equal:

$$D = \frac{t_{ON}}{t_{ON} + t_{OFF}}$$

and

$$f_{SW} = \frac{1}{t_{ON} + t_{OFF}}$$

(1)

By comparing the area of V_{ISNS} and V_{RP} over the ON period, an error signal is generated. Such a comparison is functionally equivalent to comparing the middle level of I_{SNS} to V_{RP} during the ON-period of a switching cycle. The error signal is fed to a PWM comparator circuit to produce the PWM control pulse to drive the internal power N-MOSFET. Figure 20 shows the implementation of the PWM switching signal. The error signal is fed to a PWM comparator circuit to produce the PWM control pulse to drive the internal power N-MOSFET. Figure 20 shows the implementation of the PWM switching signal.

Feature Description (continued)

In closed-loop operation, the difference between V_{MSL} and V_{RP} is reflected in the changes of the switching duty cycle of the power switch. This behavior is independent of the inductance of the inductor and input voltage because for the same set of $I_{OUT} \times R_{ISNS}$, ON time, and switching period, there exists only one V_{MSL} . Figure 21 shows two sets of current sense signals named V_{ISNS1} and V_{ISNS2} that have identical frequencies and duty cycles but different shapes of trapezoidal waveforms, each generating identical PWM signals.

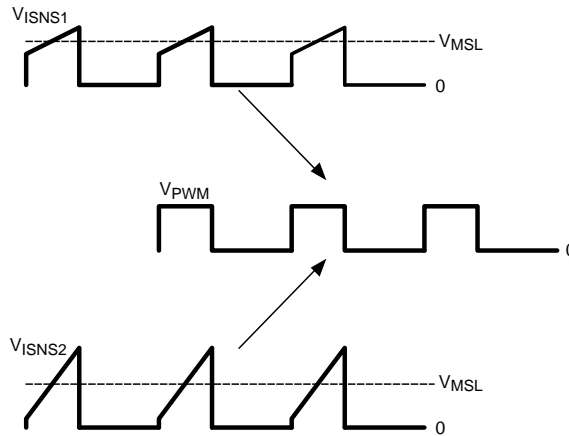

Figure 20. Pulse-Level Transformation

When V_{MSL} is higher than V_{REF} , the peak value of V_{RP} , the switching duty cycle of the power switch will be reduced to lower V_{MSL} . When V_{MSL} is lower than the peak value of V_{RP} , the switching duty cycle of the power switch will be increased to raise V_{MSL} . For example, when I_{OUT} is decreased, V_{MSL} will become lower than V_{REF} . In order to maintain output current regulation, the switching duty cycle of the power switch will be increased and eventually push up V_{MSL} until V_{MSL} equals V_{REF} . Because in typical floating buck regulators V_{MSL} is equal to $I_{OUT} \times R_{ISNS}$, true average output current regulation can be achieved by regulating V_{MSL} . Figure 22 shows the waveforms of V_{ISNS} and V_{RP} under closed loop operation.

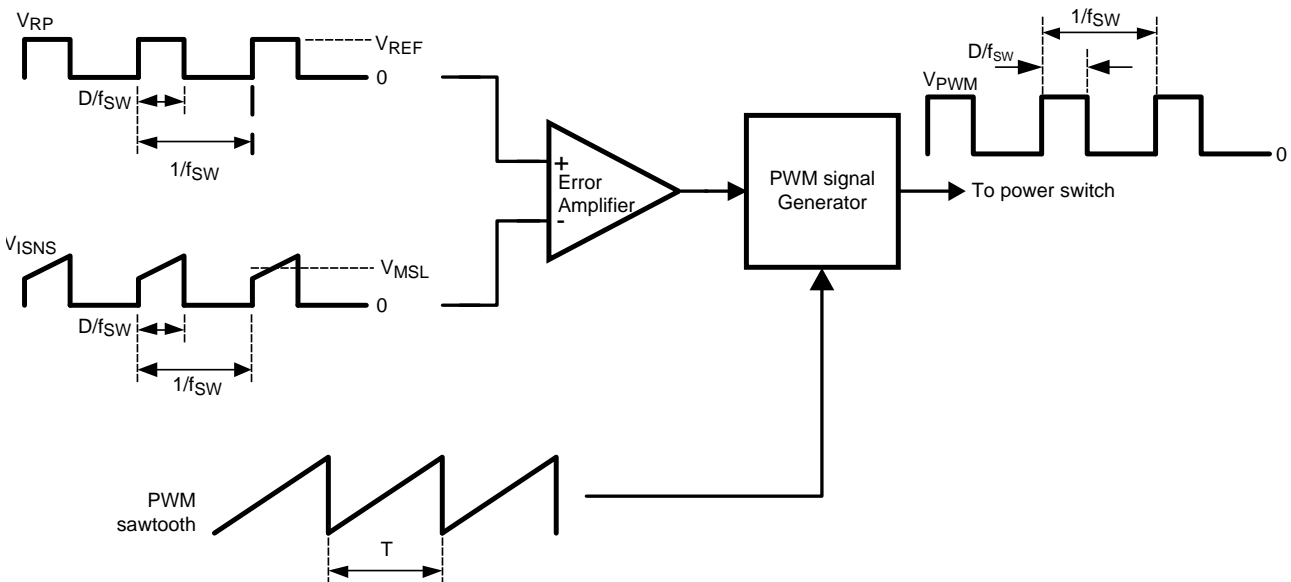

Figure 21. Implementation of the PWM Switching Signal

Feature Description (continued)

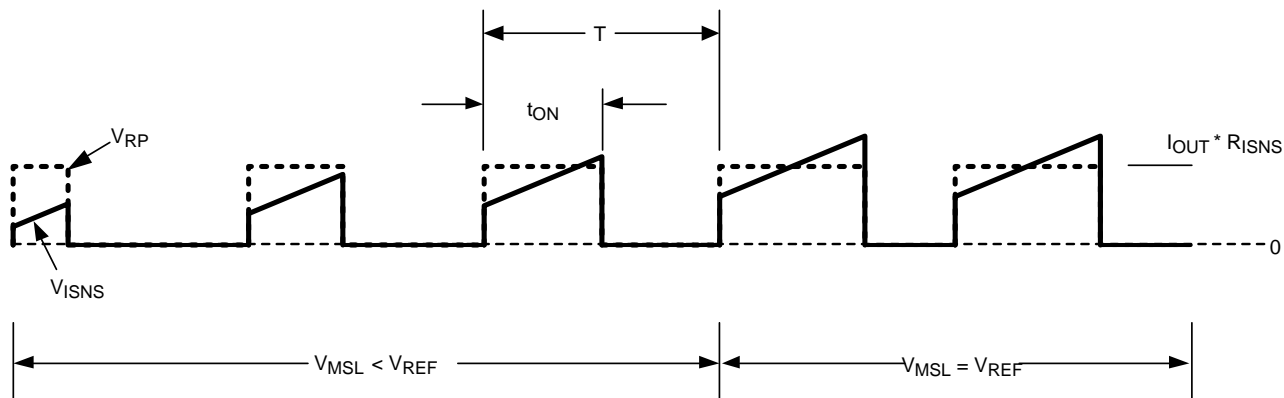

Figure 22. Waveforms of V_{ISNS} and V_{RP} Under Closed-Loop Operation

7.3.3 Internal VCC Regulator

The LM3407 has an internal 4.5 V linear regulator. This regulated voltage is used for powering the internal circuitry only and any external loading at the VCC pin is not recommended. The supply input (V_{IN}) can be connected directly to an input voltage up to 30 V. The VCC pin provides voltage regulated at 4.5 V for $V_{IN} \leq 6$ V. For 4.5 V $\leq V_{IN} \leq 6$ V, V_{IN} pin will be connected to VCC pin directly by an internal bypassing switch. For stability reason, an external capacitor C_{VCC} with at least 680 nF (1 μ F recommended) must be connected to the VCC pin.

7.3.4 Clock Generator

The LM3407 features an integrated clock generator to control the switching frequency of the converter, f_{SW} . An external resistor R_{FS} , connected to the FS pin and ground, determines the switching frequency. The oscillator frequency can be set in the range of 300 kHz to 1 MHz. The relationship between the frequency setting resistance and the oscillator frequency is described in the [Application Information](#) Section.

7.3.5 PWM Dimming of LED String

Dimming of LED brightness is achieved by Pulse Width Modulation (PWM) control of the LED current. Pulse Width Modulation control allows LED brightness to be adjusted while still maintaining accurate LED color temperature. The LM3407 accepts an external PWM dimming signal at the DIM pin. The signal is buffered before being applied to the internal switch control block responsible for controlling the ON/OFF of the power switch, Q1. The DIM pin is internally pulled low by a resistor and no LED current will be available when the DIM pin is floating or shorted to ground. Functionally, the DIM pin can also be used as an external device disable control. Device switching will be disabled if the DIM pin is not connected or tied to ground.

7.3.6 Input Under-Voltage Lock-Out (UVLO)

The LM3407 incorporates an input Under-Voltage Lock-Out (UVLO) circuit with hysteresis to keep the device disabled when the input voltage (V_{IN}) falls below the Lock-Out Low threshold, 3.4 V typical. During the device power-up, internal circuits are held inactive and the UVLO comparator monitors the voltage level at the V_{IN} pin continuously. When the V_{IN} pin voltage exceeds the UVLO threshold, 3.6 V typical, the internal circuits are then enabled and normal operation begins.

7.4 Device Functional Modes

7.4.1 Low-Power Shutdown Mode

The LM3407 comes with a dedicated device enable pin, EN, for low-power shutdown of the device. By putting the device in shutdown mode, most of the internal circuits will be disabled and the input current will reduced to below typically 50 μ A. The EN pin is internally pulled high by a 5- μ A current source. Connecting the EN pin to ground will force the device to enter low power shutdown mode. To resume normal operation, leave the EN pin open or drive with a logic high voltage.

8 Application and Implementation

NOTE

Information in the following applications sections is not part of the TI component specification, and TI does not warrant its accuracy or completeness. TI's customers are responsible for determining suitability of components for their purposes. Customers should validate and test their design implementation to confirm system functionality.

8.1 Application Information

8.1.1 Switching Frequency Selection

The selection of switching frequency is based on the consideration of the conversion efficiency, size of the passive components, and the total solution cost. In general, increasing the switching frequency allows the use of smaller external components but decreases the conversion efficiency. Thus, the selection of switching frequency is a compromise between the system requirements and may vary from design to design. The LM3407 switching frequency can be set in the range from 300 kHz to 1 MHz by adjusting the value of R_{FS} . The switching frequency is inversely proportional to the value of R_{FS} . To ensure good operation stability, a resistor with 1% tolerance between 40 k Ω and 96 k Ω and with good thermal stability is suggested.

The switching frequency is estimated by [Equation 2](#):

$$f_{SW} = \frac{40 \text{ Meg}}{R_{FS}} + 40 \text{ in kHz}$$

where

- f_{SW} is the oscillator frequency
 - R_{FS} is the frequency setting resistance
- (2)

[Equation 2](#) is only valid for oscillator frequencies in the range of 300 kHz to 1 MHz, so the frequency setting resistance will be in the range of about 40 k Ω to 150 k Ω .

8.1.2 LED Current Setting

The LED current setting is important to the lifetime, reliability, and color temperature of the LED string. The LED current should be properly selected according to the characteristics of the LED used. Over-driving the LED array can cause the color temperature to shift and will shorten the lifetime of the LEDs. The output current of the LM3407 can be set by R_{ISNS} , which is calculated from [Equation 3](#):

$$R_{ISNS} = \frac{0.198V}{I_{OUT}}$$
(3)

To ensure the accuracy of the output current, a resistor with 1% tolerance should be used for R_{ISNS} . It is also important for the designer to ensure that the rated power of the resistor is not exceeded with reasonable margin. For example, when I_{OUT} is set to 350 mA, the total power dissipation on R_{ISNS} in steady state is $(0.35 \text{ A})^2 \times 0.565 \Omega$, which equals 69 mW, indicating a resistor of 1/8W power rating is appropriate.

8.1.3 Input and Output Capacitors

The input capacitor supplies instantaneous current to the LM3407 converter when the internal power switch Q1 turns ON. The input capacitor filters the noise and transient voltage from the input power source. Using low ESR capacitors such as ceramic and tantalum capacitors is recommended. Similar to the selection criteria for the output capacitor, ceramic capacitors are the best choice for the input to the LM3407 due to their high ripple current rating, low ESR, and relatively small size compared to other types. A 4.7- μ F X7R ceramic capacitor for the input capacitor is recommended.

Application Information (continued)

The output capacitor C_{OUT} is used to reduce LED current ripple, filter noise, and smooth output voltage. This capacitor should have low ESR and adequate capacitance. Excessively large output capacitances create long enable and disable times, which is particularly significant when a high dimming frequency is used. Because the loading and input conditions differ from design to design, a 2.2- μ F X7R ceramic capacitor is a good initial selection. A DC voltage rating equal to or higher than twice the forward voltage of the LED string is recommended.

C_{OUT} is optional and can be omitted for applications where small brightness variation is acceptable. Omitting C_{OUT} also helps reduce the cost and board size of the converter. With the absence of C_{OUT} , the LED forward current equals the inductor current. To ensure proper operation of the converter, the peak inductor current must not exceed the rated forward current of the LEDs. Otherwise the LEDs may be damaged.

8.1.4 Selection of Inductor

To achieve accurate constant current output, the LM3407 is required to operate in Continuous Conduction Mode (CCM) under all operating conditions. In general, the magnitude of the inductor ripple current should be kept as small as possible. If the PCB size is not limited, higher inductance values result in better accuracy of the output current. However, to minimize the physical size of the circuit, an inductor with minimum physical outline should be selected such that the converter always operates in CCM and the peak inductor current does not exceed the saturation current limit of the inductor. The ripple and peak current of the inductor can be calculated as follows:

Inductor Peak to Peak Ripple Current:

$$I_{L(\text{ripple})} = \frac{\left[V_{IN} - (n \times V_F) - 0.198 \left(1 + \frac{1}{R_{ISNS}} \right) \right] \times (n \times V_F)}{L \times V_{IN} \times f_{SW}} \quad (4)$$

Peak Inductor Current:

$$I_{L(\text{peak})} = \frac{0.198}{R_{ISNS}} + \frac{I_{L(\text{ripple})}}{2}$$

where

- n is the number of LEDs in a string
- V_F is the forward voltage of one LED.

The minimum inductance required for the specific application can be calculated by [Equation 6](#):

$$L_{\text{min}} = \frac{\left[V_{IN} - (n \times V_F) - 0.198 \times \left(1 + \frac{1}{R_{ISNS}} \right) \right] \times (R_{ISNS} \times n \times V_F)}{0.197 \times V_{IN} \times f_{SW}} \quad (6)$$

For applications with no output capacitor in place, the magnitude of the inductor ripple current should not be more than 20% of the average inductor current, which is equivalent to the output current, I_{OUT} . However, in some situations the physical size of the required inductor may be too large and thus not allowed. The output capacitor can help absorb this current ripple to significantly reduce the ripple component along the LED string. With an output capacitor C_{OUT} in place, the magnitude of the inductor ripple current can be relaxed to 80% of the output current. [Figure 23](#) illustrates the relationship between I_{OUT} , $I_{L(\text{peak})}$, and $I_{L(\text{ripple})}$.

Application Information (continued)

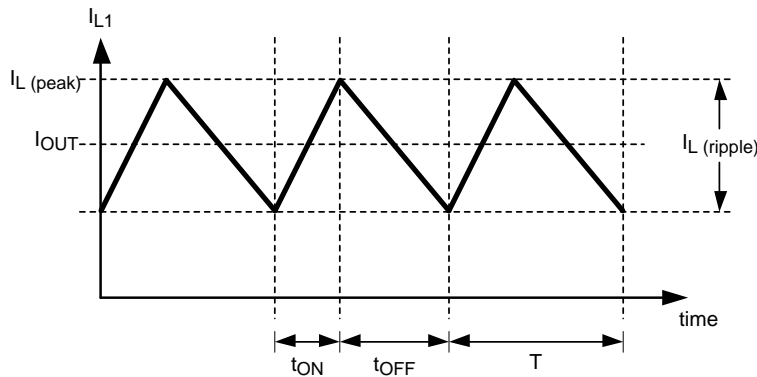

Figure 23. Relationship Between I_{OUT} , $I_{L(peak)}$ and $I_{L(ripple)}$

Table 1 provides the suggested inductance of the inductor for 500 kHz and 1 MHz switching frequency operation with $C_{OUT} = 4.7 \mu F$ and $I_{L(ripple)} = 0.8 \times I_{OUT}$

Table 1. Suggested Inductance Value of the Inductor

VIN / V	Number of LED						
	1	2	3	4	5	6	7
Inductor selection table for $F_{SW} = 500 \text{ kHz}$, $C_{OUT} = 4.7 \mu F$ (1 μF for 1 LED)							
5	22 μH						
10	22 μH	22 μH					
15	22 μH	22 μH	22 μH				
20	22 μH	33 μH	22 μH	22 μH	22 μH		
25	22 μH	33 μH	33 μH	22 μH	22 μH	22 μH	
30	22 μH	47 μH	33 μH	33 μH	33 μH	22 μH	22 μH
Inductor selection table for $F_{SW} = 1 \text{ MHz}$, $C_{OUT} = 4.7 \mu F$ (1 μF for 1 LED)							
5	22 μH						
10	22 μH	22 μH					
15	22 μH	22 μH	22 μH				
20	22 μH	22 μH	22 μH	22 μH	22 μH		
25	22 μH	33 μH	22 μH	22 μH	22 μH	22 μH	
30	22 μH	33 μH	33 μH	33 μH	22 μH	22 μH	22 μH

8.1.5 Free-Wheeling Diode

The LM3407 is a non-synchronous floating buck converter that requires an external free-wheeling diode to provide a path for recirculating current from the inductor to the LED array when the power switch is turned OFF. Selecting the free-wheeling diode depends on both the output voltage and current. The diode must have a rated reverse voltage higher than the input voltage of the converter and a peak current rating higher than the expected maximum inductor current. Using a schottky diode with a low forward voltage drop can reduce power dissipation and enhance conversion efficiency.

8.2 Typical Applications

8.2.1 LM3407 Design Example

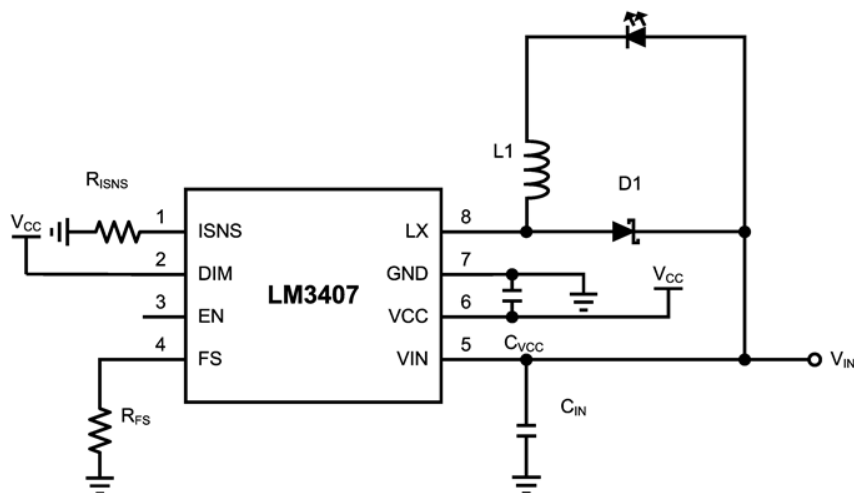

Copyright © 2016, Texas Instruments Incorporated

Figure 24. LM3407 Design Example Schematic

8.2.1.1 Design Requirements

- Input Voltage: $V_{IN} = 12\text{ V} \pm 10\%$
- LED String Voltage: $V_{LED} = 6.4\text{ V}$ (2 series white LEDs)
- LED Current: $I_{LED} = 350\text{ mA}$
- Switching Frequency: $f_{SW} = 1\text{ MHz}$

8.2.1.2 Detailed Design Procedure

This design is intended to be a small size, low-cost solution. An output capacitor will not be used to save on size and cost so a high switching frequency will be used and a higher value inductor than recommended in [Table 1](#) will be used to keep LED current ripple lower.

8.2.1.2.1 Calculate R_{ISNS}

For 350 mA LED current calculate the value for R_{ISNS} using [Equation 7](#).

$$R_{ISNS} = \frac{0.198\text{V}}{I_{OUT}} = \frac{0.198\text{V}}{0.35\text{A}} = 0.5657\Omega \quad (7)$$

Choose a standard value of $R_{ISNS} = 0.565\ \Omega$.

8.2.1.2.2 Calculate R_{FS}

Calculate the value of R_{FS} for 1-MHz switching frequency using [Equation 8](#).

$$R_{FS} = \frac{40 \times 10^6}{f_{SW} - 40} = \frac{40 \times 10^6}{1000 - 40} = 41.6\text{k}\Omega \quad (8)$$

Choose a standard value of $R_{FS} = 40.2\ \text{k}\Omega$.

8.2.1.2.3 Choose L

Referring to [Table 1](#) the recommended inductor value for 12 V input and 2 LED output is 22 μH .

Choose a higher standard value of $L = 33\ \mu\text{H}$ to reduce ripple since an output capacitor will not be used for this design.

Typical Applications (continued)

8.2.1.2.4 Choose C_{IN} and C_{VCC}

Choose the recommended values of $C_{IN} = 4.7 \mu\text{F}$ and $C_{VCC} = 1 \mu\text{F}$. C_{IN} should be a 16 V or greater ceramic capacitor and C_{VCC} should be a 10 V or greater ceramic capacitor. Both should use an X5R or X7R dielectric.

8.2.1.3 Application Curve

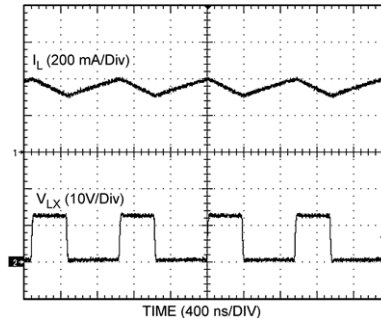
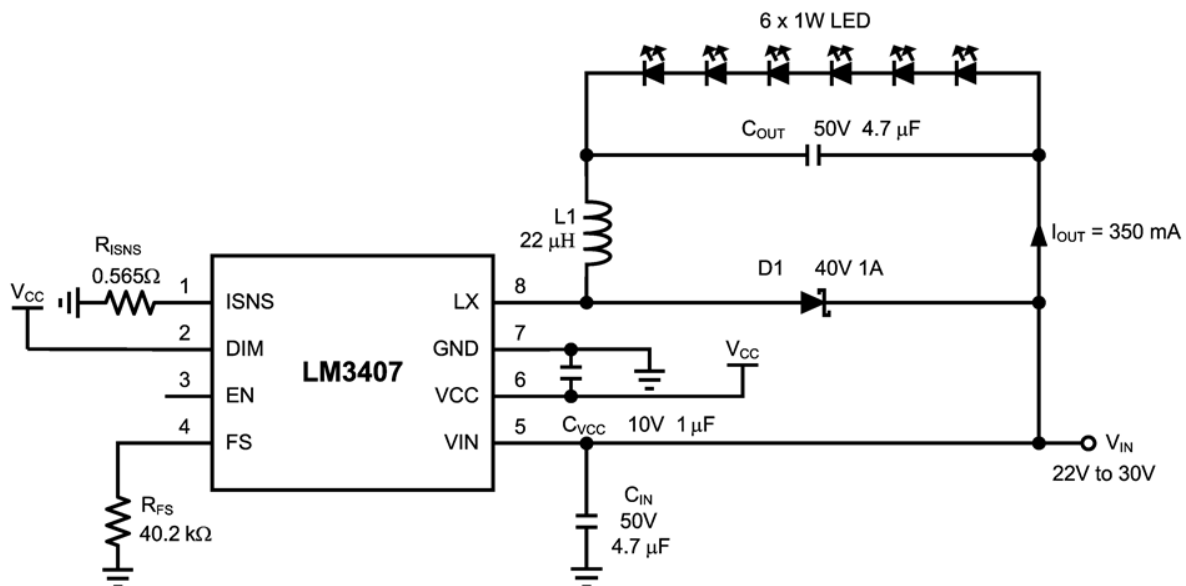

Figure 25. LED Current and Switch Voltage Waveforms

8.2.2 Typical Application for Driving 6 LEDs

Figure 26 shows a high voltage, 6-W application for driving 6 LEDs. The switching frequency is set at 1 MHz and the LED current is set at 350 mA.



Copyright © 2016, Texas Instruments Incorporated

Figure 26. LM3407 6 LED Example Schematic

Typical Applications (continued)

8.2.3 Typical Application for Driving 1 LED

Figure 27 shows a low voltage, 1-W application for driving 1 LED. The switching frequency is set at 1 MHz and the LED current is set at 350 mA.

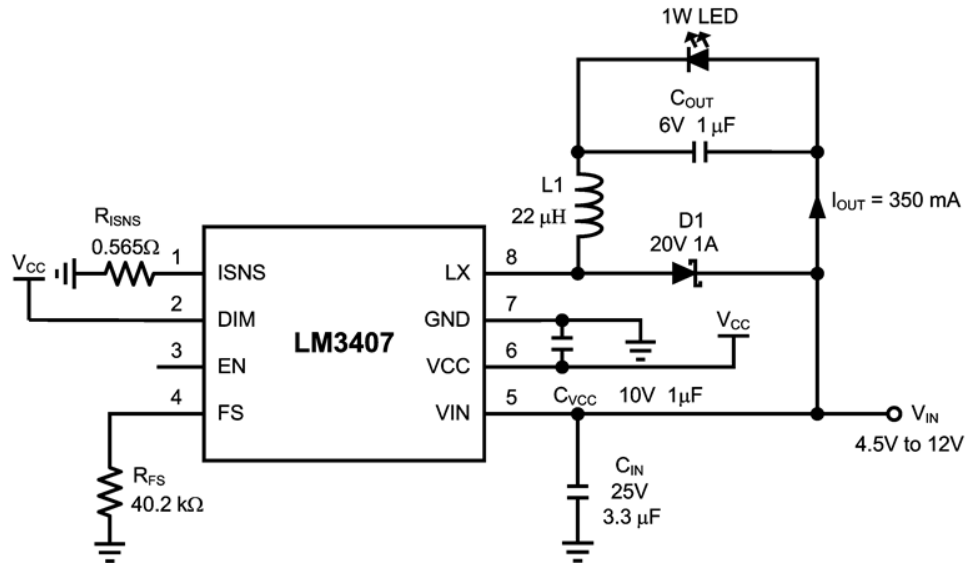

Copyright © 2016, Texas Instruments Incorporated

Figure 27. LM3407 1 LED Example Schematic

9 Power Supply Recommendations

Use any DC output power supply with a maximum voltage high enough for the application. The power supply should have a minimum current limit of at least 1 A.

10 Layout

10.1 Layout Guidelines

Because the copper traces of PCBs carry resistance and parasitic inductance, the longer the copper trace, the higher the resistance and inductance. These factors introduce voltage and current spikes to the switching nodes and may impair circuit performance. To optimize the performance of the LM3407, the rule of thumb is to keep the connections between components as short and direct as possible. Because true average current regulation is achieved by detecting the average switch current, the current setting resistor R_{ISNS} must be located as close as possible to the LM3407 to reduce the parasitic inductance of the copper trace and avoid noise pick-up. The connections between the LX pin, rectifier D1, inductor L1, and output capacitor C_{OUT} should be kept as short as possible to reduce the voltage spikes at the LX pin. TI recommends that C_{VCC} , the output filter capacitor for the internal linear regulator of the LM3407, be placed close to the VCC pin. The input filter capacitor C_{IN} should be located close to L1 and the cathode of D1. If C_{IN} is connected to the VIN pin by a long trace, a 0.1- μ F capacitor should be added close to VIN pin for noise filtering.

CAUTION

In normal operation, heat will be generated inside the LM3407 and may damage the device if no thermal management is applied. For more details on switching power supply layout considerations see [AN-1149 Layout Guidelines for Switching Power Supplies](#) (SNVA021).

10.2 Layout Example

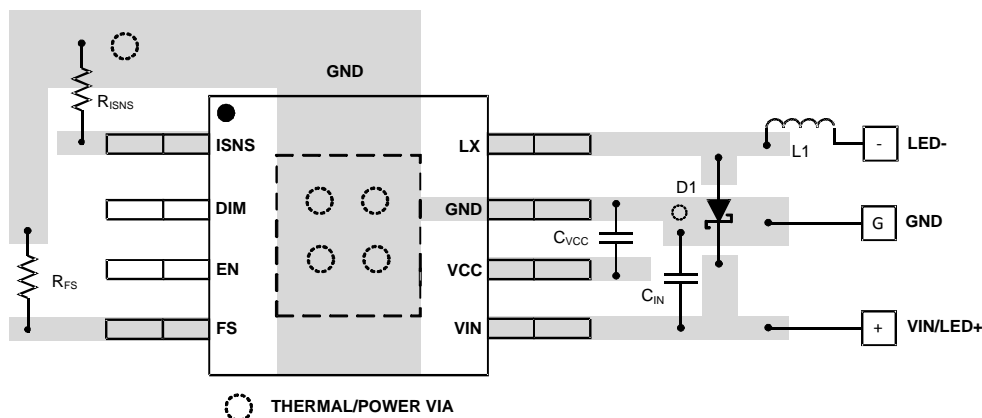

Figure 28. Layout Recommendation

11 Device and Documentation Support

11.1 Documentation Support

11.1.1 Related Documentation

For related documentation see the following:

[AN-1149 Layout Guidelines for Switching Power Supplies](#) (SNVA021).

11.2 Receiving Notification of Documentation Updates

To receive notification of documentation updates, navigate to the device product folder on ti.com. In the upper right corner, click on *Alert me* to register and receive a weekly digest of any product information that has changed. For change details, review the revision history included in any revised document.

11.3 Community Resources

The following links connect to TI community resources. Linked contents are provided "AS IS" by the respective contributors. They do not constitute TI specifications and do not necessarily reflect TI's views; see TI's [Terms of Use](#).

TI E2E™ Online Community *TI's Engineer-to-Engineer (E2E) Community*. Created to foster collaboration among engineers. At e2e.ti.com, you can ask questions, share knowledge, explore ideas and help solve problems with fellow engineers.

Design Support *TI's Design Support* Quickly find helpful E2E forums along with design support tools and contact information for technical support.

11.4 Trademarks

E2E is a trademark of Texas Instruments.
All other trademarks are the property of their respective owners.

11.5 Electrostatic Discharge Caution



These devices have limited built-in ESD protection. The leads should be shorted together or the device placed in conductive foam during storage or handling to prevent electrostatic damage to the MOS gates.

11.6 Glossary

[SLYZ022](#) — *TI Glossary*.

This glossary lists and explains terms, acronyms, and definitions.

12 Mechanical, Packaging, and Orderable Information

The following pages include mechanical, packaging, and orderable information. This information is the most current data available for the designated devices. This data is subject to change without notice and revision of this document. For browser-based versions of this data sheet, refer to the left-hand navigation.

PACKAGING INFORMATION

Orderable Device	Status (1)	Package Type	Package Drawing	Pins	Package Qty	Eco Plan (2)	Lead/Ball Finish (6)	MSL Peak Temp (3)	Op Temp (°C)	Device Marking (4/5)	Samples
LM3407MY/NOPB	ACTIVE	MSOP- PowerPAD	DGN	8	1000	Green (RoHS & no Sb/Br)	CU SN	Level-1-260C-UNLIM	-40 to 125	STZB	Samples
LM3407MYX/NOPB	ACTIVE	MSOP- PowerPAD	DGN	8	3500	Green (RoHS & no Sb/Br)	CU SN	Level-1-260C-UNLIM	-40 to 125	STZB	Samples

(1) The marketing status values are defined as follows:

ACTIVE: Product device recommended for new designs.

LIFEBUY: TI has announced that the device will be discontinued, and a lifetime-buy period is in effect.

NRND: Not recommended for new designs. Device is in production to support existing customers, but TI does not recommend using this part in a new design.

PREVIEW: Device has been announced but is not in production. Samples may or may not be available.

OBsolete: TI has discontinued the production of the device.

(2) Eco Plan - The planned eco-friendly classification: Pb-Free (RoHS), Pb-Free (RoHS Exempt), or Green (RoHS & no Sb/Br) - please check <http://www.ti.com/productcontent> for the latest availability information and additional product content details.

TBD: The Pb-Free/Green conversion plan has not been defined.

Pb-Free (RoHS): TI's terms "Lead-Free" or "Pb-Free" mean semiconductor products that are compatible with the current RoHS requirements for all 6 substances, including the requirement that lead not exceed 0.1% by weight in homogeneous materials. Where designed to be soldered at high temperatures, TI Pb-Free products are suitable for use in specified lead-free processes.

Pb-Free (RoHS Exempt): This component has a RoHS exemption for either 1) lead-based flip-chip solder bumps used between the die and package, or 2) lead-based die adhesive used between the die and leadframe. The component is otherwise considered Pb-Free (RoHS compatible) as defined above.

Green (RoHS & no Sb/Br): TI defines "Green" to mean Pb-Free (RoHS compatible), and free of Bromine (Br) and Antimony (Sb) based flame retardants (Br or Sb do not exceed 0.1% by weight in homogeneous material)

(3) MSL, Peak Temp. - The Moisture Sensitivity Level rating according to the JEDEC industry standard classifications, and peak solder temperature.

(4) There may be additional marking, which relates to the logo, the lot trace code information, or the environmental category on the device.

(5) Multiple Device Markings will be inside parentheses. Only one Device Marking contained in parentheses and separated by a "~" will appear on a device. If a line is indented then it is a continuation of the previous line and the two combined represent the entire Device Marking for that device.

(6) Lead/Ball Finish - Orderable Devices may have multiple material finish options. Finish options are separated by a vertical ruled line. Lead/Ball Finish values may wrap to two lines if the finish value exceeds the maximum column width.

Important Information and Disclaimer: The information provided on this page represents TI's knowledge and belief as of the date that it is provided. TI bases its knowledge and belief on information provided by third parties, and makes no representation or warranty as to the accuracy of such information. Efforts are underway to better integrate information from third parties. TI has taken and continues to take reasonable steps to provide representative and accurate information but may not have conducted destructive testing or chemical analysis on incoming materials and chemicals. TI and TI suppliers consider certain information to be proprietary, and thus CAS numbers and other limited information may not be available for release.

In no event shall TI's liability arising out of such information exceed the total purchase price of the TI part(s) at issue in this document sold by TI to Customer on an annual basis.

TAPE AND REEL INFORMATION

QUADRANT ASSIGNMENTS FOR PIN 1 ORIENTATION IN TAPE

*All dimensions are nominal

Device	Package Type	Package Drawing	Pins	SPQ	Reel Diameter (mm)	Reel Width W1 (mm)	A0 (mm)	B0 (mm)	K0 (mm)	P1 (mm)	W (mm)	Pin1 Quadrant
LM3407MY/NOPB	MSOP-Power PAD	DGN	8	1000	178.0	12.4	5.3	3.4	1.4	8.0	12.0	Q1
LM3407MYX/NOPB	MSOP-Power PAD	DGN	8	3500	330.0	12.4	5.3	3.4	1.4	8.0	12.0	Q1

TAPE AND REEL BOX DIMENSIONS

*All dimensions are nominal

Device	Package Type	Package Drawing	Pins	SPQ	Length (mm)	Width (mm)	Height (mm)
LM3407MY/NOPB	MSOP-PowerPAD	DGN	8	1000	210.0	185.0	35.0
LM3407MYX/NOPB	MSOP-PowerPAD	DGN	8	3500	367.0	367.0	35.0

DGN0008A

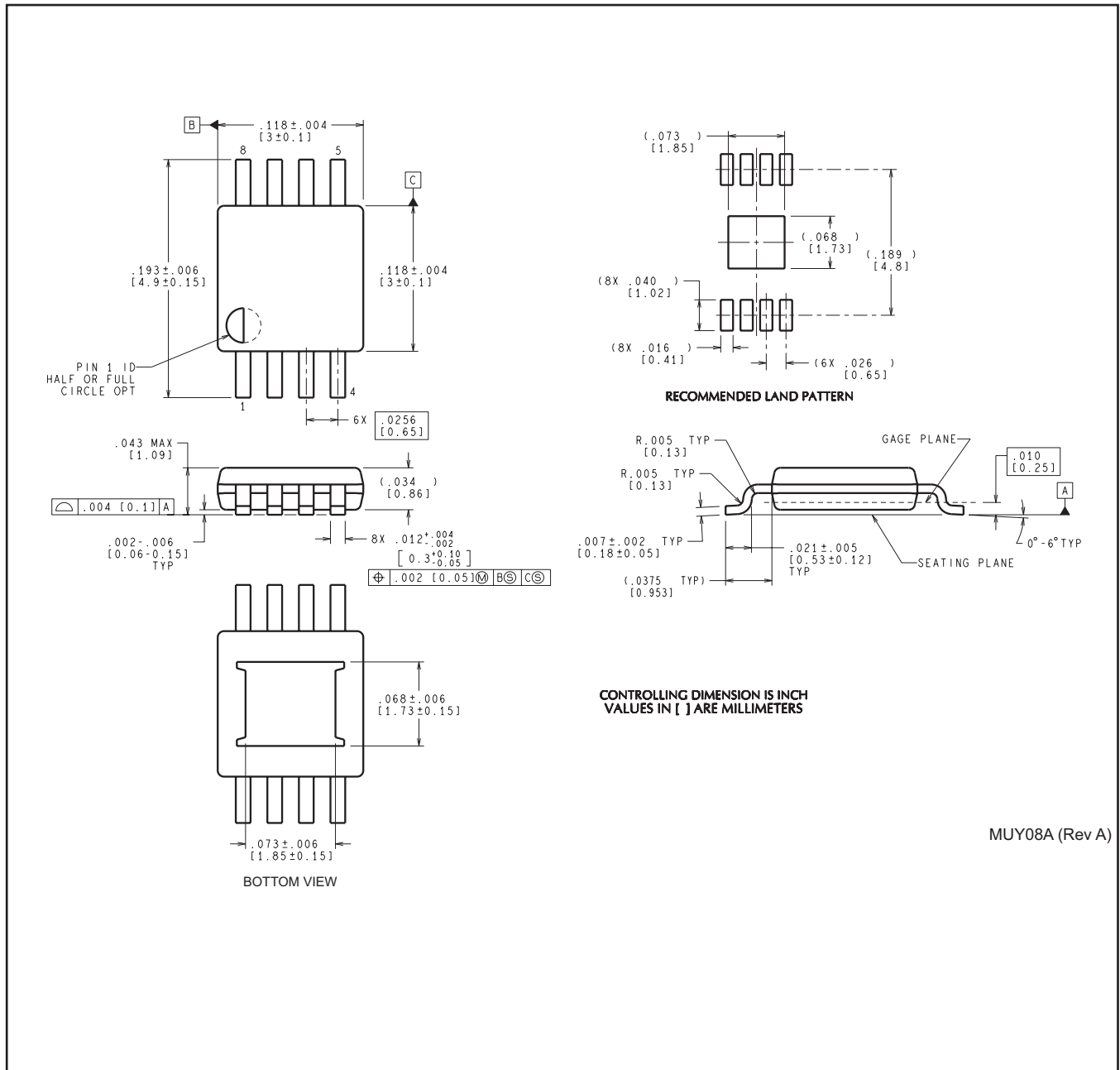

MUY08A (Rev A)

IMPORTANT NOTICE

Texas Instruments Incorporated and its subsidiaries (TI) reserve the right to make corrections, enhancements, improvements and other changes to its semiconductor products and services per JESD46, latest issue, and to discontinue any product or service per JESD48, latest issue. Buyers should obtain the latest relevant information before placing orders and should verify that such information is current and complete. All semiconductor products (also referred to herein as "components") are sold subject to TI's terms and conditions of sale supplied at the time of order acknowledgment.

TI warrants performance of its components to the specifications applicable at the time of sale, in accordance with the warranty in TI's terms and conditions of sale of semiconductor products. Testing and other quality control techniques are used to the extent TI deems necessary to support this warranty. Except where mandated by applicable law, testing of all parameters of each component is not necessarily performed.

TI assumes no liability for applications assistance or the design of Buyers' products. Buyers are responsible for their products and applications using TI components. To minimize the risks associated with Buyers' products and applications, Buyers should provide adequate design and operating safeguards.

TI does not warrant or represent that any license, either express or implied, is granted under any patent right, copyright, mask work right, or other intellectual property right relating to any combination, machine, or process in which TI components or services are used. Information published by TI regarding third-party products or services does not constitute a license to use such products or services or a warranty or endorsement thereof. Use of such information may require a license from a third party under the patents or other intellectual property of the third party, or a license from TI under the patents or other intellectual property of TI.

Reproduction of significant portions of TI information in TI data books or data sheets is permissible only if reproduction is without alteration and is accompanied by all associated warranties, conditions, limitations, and notices. TI is not responsible or liable for such altered documentation. Information of third parties may be subject to additional restrictions.

Resale of TI components or services with statements different from or beyond the parameters stated by TI for that component or service voids all express and any implied warranties for the associated TI component or service and is an unfair and deceptive business practice. TI is not responsible or liable for any such statements.

Buyer acknowledges and agrees that it is solely responsible for compliance with all legal, regulatory and safety-related requirements concerning its products, and any use of TI components in its applications, notwithstanding any applications-related information or support that may be provided by TI. Buyer represents and agrees that it has all the necessary expertise to create and implement safeguards which anticipate dangerous consequences of failures, monitor failures and their consequences, lessen the likelihood of failures that might cause harm and take appropriate remedial actions. Buyer will fully indemnify TI and its representatives against any damages arising out of the use of any TI components in safety-critical applications.

In some cases, TI components may be promoted specifically to facilitate safety-related applications. With such components, TI's goal is to help enable customers to design and create their own end-product solutions that meet applicable functional safety standards and requirements. Nonetheless, such components are subject to these terms.

No TI components are authorized for use in FDA Class III (or similar life-critical medical equipment) unless authorized officers of the parties have executed a special agreement specifically governing such use.

Only those TI components which TI has specifically designated as military grade or "enhanced plastic" are designed and intended for use in military/aerospace applications or environments. Buyer acknowledges and agrees that any military or aerospace use of TI components which have **not** been so designated is solely at the Buyer's risk, and that Buyer is solely responsible for compliance with all legal and regulatory requirements in connection with such use.

TI has specifically designated certain components as meeting ISO/TS16949 requirements, mainly for automotive use. In any case of use of non-designated products, TI will not be responsible for any failure to meet ISO/TS16949.

Products

Audio	www.ti.com/audio
Amplifiers	amplifier.ti.com
Data Converters	dataconverter.ti.com
DLP® Products	www.dlp.com
DSP	dsp.ti.com
Clocks and Timers	www.ti.com/clocks
Interface	interface.ti.com
Logic	logic.ti.com
Power Mgmt	power.ti.com
Microcontrollers	microcontroller.ti.com
RFID	www.ti-rfid.com
OMAP Applications Processors	www.ti.com/omap
Wireless Connectivity	www.ti.com/wirelessconnectivity

Applications

Automotive and Transportation	www.ti.com/automotive
Communications and Telecom	www.ti.com/communications
Computers and Peripherals	www.ti.com/computers
Consumer Electronics	www.ti.com/consumer-apps
Energy and Lighting	www.ti.com/energy
Industrial	www.ti.com/industrial
Medical	www.ti.com/medical
Security	www.ti.com/security
Space, Avionics and Defense	www.ti.com/space-avionics-defense
Video and Imaging	www.ti.com/video

TI E2E Community

e2e.ti.com

Looking for pricing, stock, or lifecycle information?

Click below to explore more details on WIN SOURCE:

 [View LM3407MYX/NOPB on WIN SOURCE](#)

 [Texas Instruments](#) Information

Optimize Your Supply Chain with WIN SOURCE Solutions

-  Global Sourcing Solution
-  Obsolete Management
-  Cost Control Management
-  Shortage Management
-  Alternative Solution
-  Excess Inventory Management