



**THE DATASHEET OF
ISO7221CQDRQ1**



DUAL DIGITAL ISOLATORS

1 FEATURES

- Qualified for Automotive Applications
- 1-Mbps and 25-Mbps Signaling Rate Options
 - Low Channel-to-Channel Output Skew: 1 ns (Max)
 - Low Pulse-Width Distortion (PWD): 1 ns (Max)
 - Low Jitter Content: 1 ns (Typ) at 150 Mbps
- 25-Year (Typ) Life at Rated Voltage (See Application Report [SLLA197](#) and [Figure 15](#))
- 4000- V_{peak} Isolation, 560 V_{peak} V_{IORM}
 - UL 1577, DIN VDE V 0884-11:2017-01, DIN EN 61010-1, IEC 60950-1, IEC 62368-1 and CSA Approved
 - 50 kV/ μs Typical Transient Immunity
- Operates with 3.3-V or 5-V Supplies
- 4 kV ESD Protection
- High Electromagnetic Immunity
- -40°C to 125°C Operating Free-Air Temperature Range

2 DESCRIPTION

The ISO7220 and ISO7221 are dual-channel digital isolators. To facilitate PCB layout, the channels are oriented in the same direction in the ISO7220 and in opposite directions in the ISO7221. These devices have a logic input and output buffer separated by TI's silicon-dioxide (SiO_2) isolation barrier, providing galvanic isolation of up to 4000 V. Used in conjunction with isolated power supplies, these devices block high voltage, isolate grounds, and prevent noise currents on a data bus or other circuits from entering the local ground and interfering with or damaging sensitive circuitry.

A binary input signal is conditioned, translated to a balanced signal, then differentiated by the capacitive isolation barrier. Across the isolation barrier, a differential comparator receives the logic transition information, then sets or resets a flip-flop and the output circuit accordingly. A periodic update pulse is sent across the barrier to ensure the proper dc level of the output. If this dc-refresh pulse is not received every 4 μs , the input is assumed to be unpowered or not being actively driven, and the failsafe circuit drives the output to a logic high state.

The small capacitance and resulting time constant provide fast operation with signaling rates available from 0 Mbps (dc) to 25 Mbps. ⁽¹⁾The A-option and C-option devices have TTL input thresholds and a noise filter at the input that prevents transient pulses from being passed to the output of the device.

These devices require two supply voltages of 3.3 V, 5 V, or any combination. All inputs are 5-V tolerant when supplied from a 3.3-V supply and all outputs are 4-mA CMOS.

These devices are characterized for operation over the ambient temperature range of -40°C to 125°C .

(1) The signaling rate of a line is the number of voltage transitions that are made per second expressed in the units bps (bits per second).

2.1 Electrostatic Discharge Caution



This integrated circuit can be damaged by ESD. Texas Instruments recommends that all integrated circuits be handled with appropriate precautions. Failure to observe proper handling and installation procedures can cause damage.

ESD damage can range from subtle performance degradation to complete device failure. Precision integrated circuits may be more susceptible to damage because very small parametric changes could cause the device not to meet its published specifications.



Table 1. ORDERING INFORMATION⁽¹⁾

T _A	SIGNALING RATE	PACKAGE ⁽²⁾		ORDERABLE PART NUMBER	TOP-SIDE MARKING
–40°C to 125°C	1 Mbps	SOIC – D	Reel of 2500	ISO7220AQDRQ1	7220AQ
	1 Mbps	SOIC – D	Reel of 2500	ISO7221AQDRQ1	7221AQ
	25 Mbps	SOIC – D	Reel of 2500	ISO7221CQDRQ1	7221CQ

(1) For the most current package and ordering information, see the Package Option Addendum at the end of this document, or see the TI web site at www.ti.com.

(2) Package drawings, thermal data, and symbolization are available at www.ti.com/packaging.

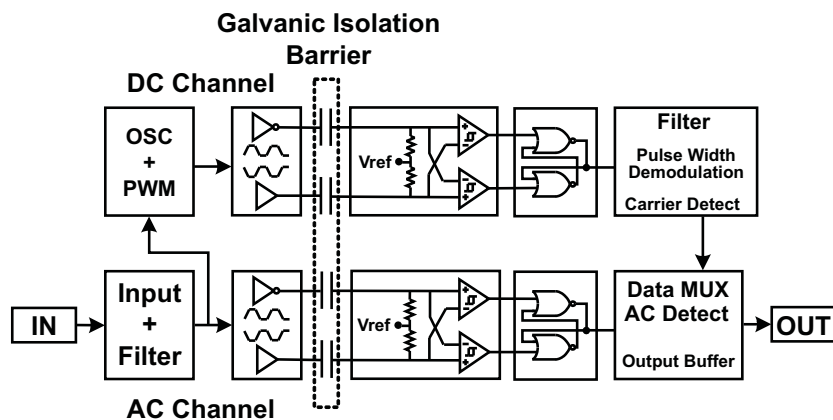
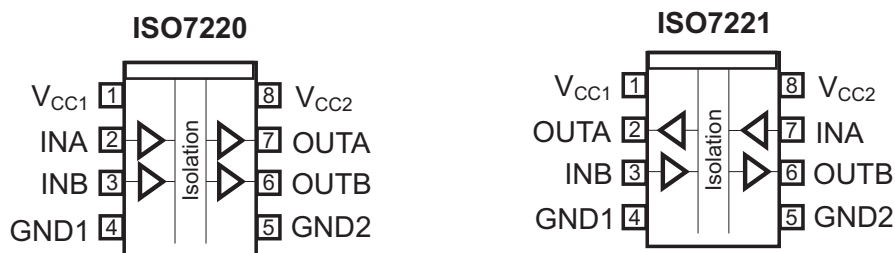

Figure 1. Single-Channel Function Diagram

2.1 REGULATORY INFORMATION

VDE	CSA	UL
Certified according to DIN VDE V 0884-11:2017-01 and DIN EN 61010-1	Certified according to IEC 60950-1 and IEC 62368-1	Recognized under UL 1577 Component Recognition Program ⁽¹⁾
File Number: 40047657	Master Contract Number: 220991	File Number: E181974

(1) Production tested $\geq 3000 V_{RMS}$ for 1 second in accordance with UL 1577.

2.2 ABSOLUTE MAXIMUM RATINGS⁽¹⁾

V_{CC}	Supply voltage ⁽²⁾ , V_{CC1} , V_{CC2}			–0.5 V to 6 V
V_I	Voltage at IN, OUT			–0.5 V to $V_{CC} + 0.5$ V ⁽³⁾
I_O	Output current			±15 mA
ESD	Electrostatic discharge	Human-Body Model	All pins	±4 kV
		Field-Induced Charged-Device Model		±1 kV
		Machine Model		±200 V
T_J	Maximum junction temperature			150°C
T_{stg}	Storage temperature			–65°C to 150°C

- (1) Stresses beyond those listed under *absolute maximum ratings* may cause permanent damage to the device. These are stress ratings only and functional operation of the device at these or any other conditions beyond those indicated under *recommended operating conditions* is not implied. Exposure to absolute-maximum-rated conditions for extended periods may affect device reliability.
- (2) All voltage values except differential I/O bus voltages are with respect to network ground terminal and are peak voltage values.
- (3) Maximum voltage must not exceed 6 V.

2.3 RECOMMENDED OPERATING CONDITIONS

			MIN	TYP	MAX	UNIT
V_{CC}	Supply voltage ⁽¹⁾	V_{CC1} , V_{CC2}	3		5.5	V
I_{OH}	High-level output current				4	mA
I_{OL}	Low-level output current		–4			mA
t_{ui}	Input pulse width	ISO722xA	1			µs
		ISO722xC	40			ns
1/ t_{ui}	Signaling rate	ISO722xA	0		1000	kbps
		ISO722xC	0		25	Mbps
V_{IH}	High-level input voltage		2		V_{CC}	V
V_{IL}	Low-level input voltage		0		0.8	V
T_A	Ambient temperature		–40		125	°C
T_J	Operating virtual-junction temperature		–40		150	°C
H	External magnetic field-strength immunity per IEC 61000-4-8 and IEC 61000-4-9 certification				1000	A/m

- (1) For the 5-V operation, V_{CC1} or V_{CC2} is specified from 4.5 V to 5.5 V.
For the 3.3-V operation, V_{CC1} or V_{CC2} is specified from 3 V to 3.6 V.

2.4 ELECTRICAL CHARACTERISTICS

V_{CC1} and V_{CC2} at 5 V⁽¹⁾, over recommended operating conditions (unless otherwise noted)

PARAMETER		TEST CONDITIONS		MIN	TYP	MAX	UNIT
I_{CC1}	Supply current, V_{CC1}	ISO7220x	Quiescent	$V_I = V_{CC}$ or 0 V, no load	1	2	mA
		ISO7221x			8.5	17	
		ISO7220A	1 Mbps		2	3	
		ISO7221A			10	18	
		ISO7221C			25 Mbps	12	
I_{CC2}	Supply current, V_{CC2}	ISO7220x	Quiescent	$V_I = V_{CC}$ or 0 V, no load	16	31	mA
		ISO7221x			8.5	17	
		ISO7220A	1 Mbps		17	32	
		ISO7221A			10	18	
		ISO7221C			25 Mbps	12	
V_{OH}	High-level output voltage	$I_{OH} = -4$ mA, See Figure 2		$V_{CC} - 0.8$	4.6		V
		$I_{OH} = -20$ μ A, See Figure 2		$V_{CC} - 0.1$	5		
V_{OL}	Low-level output voltage	$I_{OL} = 4$ mA, See Figure 2			0.2	0.4	V
		$I_{OL} = 20$ μ A, See Figure 2			0	0.1	
$V_{I(HYS)}$	Input voltage hysteresis				150		mV
I_{IH}	High-level input current	IN from 0 V to V_{CC}				10	μ A
I_{IL}	Low-level input current	IN from 0 V to V_{CC}		-10			μ A
C_I	Input capacitance to ground	IN at V_{CC} , $V_I = 0.4 \sin(4E6\pi t)$			1		pF
CMTI	Common-mode transient immunity	$V_I = V_{CC}$ or 0 V, See Figure 4		25	50		kV/ μ s

- (1) For the 5-V operation, V_{CC1} or V_{CC2} is specified from 4.5 V to 5.5 V.
For the 3.3-V operation, V_{CC1} or V_{CC2} is specified from 3 V to 3.6 V.

2.5 SWITCHING CHARACTERISTICS

$V_{CC1} = V_{CC2} = 5$ V \pm 10%, over recommended operating conditions (unless otherwise noted)

PARAMETER		TEST CONDITIONS		MIN	TYP	MAX	UNIT
t_{pLH} , t_{pHL}	Propagation delay	ISO722xA	See Figure 2	280	405	600	ns
PWD	Pulse-width distortion $ t_{pHL} - t_{pLH} ^{(1)}$			1	18	ns	
t_{pLH} , t_{pHL}	Propagation delay	ISO722xC	See Figure 2	22	32	42	ns
PWD	Pulse-width distortion $ t_{pHL} - t_{pLH} ^{(1)}$			1	2	ns	
$t_{sk(pp)}$	Part-to-part skew ⁽²⁾	ISO722xA				180	ns
		ISO722xC				10	
$t_{sk(o)}$	Channel-to-channel output skew ⁽³⁾	ISO7220A			3	15	ns
t_r	Output signal rise time	See Figure 2			1		ns
t_f	Output signal fall time	See Figure 2			1		ns
t_{fs}	Failsafe output delay time from input power loss	See Figure 3			3		μ s

- (1) Also referred to as pulse skew.
(2) $t_{sk(pp)}$ is the magnitude of the difference in propagation delay times between any specified terminals of two devices when both devices operate with the same supply voltages, at the same temperature, and have identical packages and test circuits.
(3) $t_{sk(o)}$ is the skew between specified outputs of a single device with all driving inputs connected together and the outputs switching in the same direction while driving identical specified loads.

2.6 ELECTRICAL CHARACTERISTICS

 $V_{CC1} = 5\text{ V}$, $V_{CC2} = 3.3\text{ V}^{(1)}$, over recommended operating conditions (unless otherwise noted)

PARAMETER		TEST CONDITIONS		MIN	TYP	MAX	UNIT
I_{CC1}	Supply current, V_{CC1}	ISO7220x	Quiescent	$V_I = V_{CC}$ or 0 V, no load	1	2	mA
		ISO7221x			8.5	17	
		ISO7220A	1 Mbps	$V_I = V_{CC}$ or 0 V, no load	2	3	
		ISO7221A			10	18	
		ISO7221C			25 Mbps	$V_I = V_{CC}$ or 0 V, no load	
I_{CC2}	Supply current, V_{CC2}	ISO7220x	Quiescent	$V_I = V_{CC}$ or 0 V, no load	8	18	mA
		ISO7221x			4.3	9.5	
		ISO7220A	1 Mbps	$V_I = V_{CC}$ or 0 V, no load	9	19	
		ISO7221A			5	11	
		ISO7221C			25 Mbps	$V_I = V_{CC}$ or 0 V, no load	
V_{OH}	High-level output voltage	ISO7220x	$I_{OH} = -4\text{ mA}$, See Figure 2	$V_{CC} - 0.4$		V	
		ISO7221x (5-V side)		$V_{CC} - 0.8$			
				$I_{OH} = -20\text{ }\mu\text{A}$, See Figure 2	$V_{CC} - 0.1$		
V_{OL}	Low-level output voltage		$I_{OL} = 4\text{ mA}$, See Figure 2	0.4		V	
			$I_{OL} = 20\text{ }\mu\text{A}$, See Figure 2	0.1			
$V_{I(HYS)}$	Input voltage hysteresis			150		mV	
I_{IH}	High-level input current		IN from 0 V to V_{CC}			10	μA
I_{IL}	Low-level input current		IN from 0 V to V_{CC}	-10			μA
C_1	Input capacitance to ground		IN at V_{CC} , $V_I = 0.4\text{ sin}(4E6\pi t)$		1		pF
CMTI	Common-mode transient immunity		$V_I = V_{CC}$ or 0 V, See Figure 4	15	40		kV/ μs

- (1) For the 5-V operation, V_{CC1} or V_{CC2} is specified from 4.5 V to 5.5 V.
For the 3.3-V operation, V_{CC1} or V_{CC2} is specified from 3 V to 3.6 V.

2.7 SWITCHING CHARACTERISTICS

 $V_{CC1} = 5\text{ V} \pm 10\%$, $V_{CC2} = 3.3\text{ V} \pm 10\%$, over recommended operating conditions (unless otherwise noted)

PARAMETER		TEST CONDITIONS		MIN	TYP	MAX	UNIT
t_{pLH} , t_{pHL}	Propagation delay	ISO722xA	See Figure 2	285	410	585	ns
PWD	Pulse-width distortion $ t_{pHL} - t_{pLH} ^{(1)}$			1	18	ns	
t_{pLH} , t_{pHL}	Propagation delay	ISO722xC	See Figure 2	25	36	48	ns
PWD	Pulse-width distortion $ t_{pHL} - t_{pLH} ^{(1)}$			1	2	ns	
$t_{sk(pp)}$	Part-to-part skew ⁽²⁾	ISO722xA				180	ns
		ISO722xC				10	
$t_{sk(o)}$	Channel-to-channel output skew ⁽³⁾	ISO7220A			3	15	ns
t_r	Output signal rise time		See Figure 2		2		ns
t_f	Output signal fall time		See Figure 2		2		
t_{fs}	Failsafe output delay time from input power loss		See Figure 3		3		μs

- (1) Also referred to as pulse skew.
(2) $t_{sk(pp)}$ is the magnitude of the difference in propagation delay times between any specified terminals of two devices when both devices operate with the same supply voltages, at the same temperature, and have identical packages and test circuits.
(3) $t_{sk(o)}$ is the skew between specified outputs of a single device with all driving inputs connected together and the outputs switching in the same direction while driving identical specified loads.

2.8 ELECTRICAL CHARACTERISTICS

$V_{CC1} = 3.3\text{ V}$, $V_{CC2} = 5\text{ V}^{(1)}$, over recommended operating conditions (unless otherwise noted)

PARAMETER		TEST CONDITIONS	MIN	TYP	MAX	UNIT				
I_{CC1}	Supply current, V_{CC1}	$V_I = V_{CC}$ or 0 V, no load				mA	ISO7220x	Quiescent	0.6	1
							ISO7221x	Quiescent	4.3	9.5
	ISO7220A						1 Mbps	1	2	
	ISO7221A						1 Mbps	5	11	
	ISO7221C						25 Mbps	6	12	
I_{CC2}	Supply current, V_{CC2}	$V_I = V_{CC}$ or 0 V, no load				mA	ISO7220x	Quiescent	16	31
							ISO7221x	Quiescent	8.5	17
	ISO7220A						1 Mbps	18	32	
	ISO7221A						1 Mbps	10	18	
	ISO7221C						25 Mbps	12	22	
V_{OH}	High-level output voltage	$I_{OH} = -4\text{ mA}$, See Figure 2				V	ISO7220x		$V_{CC} - 0.8$	
							ISO7221x (3.3-V side)		$V_{CC} - 0.4$	
								$I_{OH} = -20\text{ }\mu\text{A}$, See Figure 2	$V_{CC} - 0.1$	
V_{OL}	Low-level output voltage	$I_{OL} = 4\text{ mA}$, See Figure 2				V			0.4	
								$I_{OL} = 20\text{ }\mu\text{A}$, See Figure 2	0	0.1
$V_{I(HYS)}$	Input threshold voltage hysteresis							150		mV
I_{IH}	High-level input current	IN from 0 V or V_{CC}							10	μA
I_{IL}	Low-level input current	IN from 0 V or V_{CC}						-10		μA
C_1	Input capacitance to ground	IN at V_{CC} , $V_I = 0.4\text{ sin}(4E6\pi t)$							1	pF
CMTI	Common-mode transient immunity	$V_I = V_{CC}$ or 0 V, See Figure 4						15	40	kV/ μs

- (1) For the 5-V operation, V_{CC1} or V_{CC2} is specified from 4.5 V to 5.5 V.
For the 3.3-V operation, V_{CC1} or V_{CC2} is specified from 3 V to 3.6 V.

2.9 SWITCHING CHARACTERISTICS

$V_{CC1} = 3.3\text{ V} \pm 10\%$, $V_{CC2} = 5\text{ V} \pm 10\%$, over recommended operating conditions (unless otherwise noted)

PARAMETER		TEST CONDITIONS	MIN	TYP	MAX	UNIT
t_{pLH} , t_{pHL}	Propagation delay	ISO722xA See Figure 2	285	395	605	ns
PWD	Pulse-width distortion $ t_{pHL} - t_{pLH} ^{(1)}$					
t_{pLH} , t_{pHL}	Propagation delay	ISO722xC See Figure 2	24	36	48	ns
PWD	Pulse-width distortion $ t_{pHL} - t_{pLH} ^{(1)}$					
$t_{sk(pp)}$	Part-to-part skew ⁽²⁾	ISO722xA			190	ns
		ISO722xC			10	
$t_{sk(o)}$	Channel-to-channel output skew ⁽³⁾	ISO7220A		3	15	ns
t_r	Output signal rise time	See Figure 2		1		ns
t_f	Output signal fall time	See Figure 2		1		ns
t_{fs}	Failsafe output delay time from input power loss	See Figure 3		3		μs

- (1) Also referred to as pulse skew.
(2) $t_{sk(pp)}$ is the magnitude of the difference in propagation delay times between any specified terminals of two devices when both devices operate with the same supply voltages, at the same temperature, and have identical packages and test circuits.
(3) $t_{sk(o)}$ is the skew between specified outputs of a single device with all driving inputs connected together and the outputs switching in the same direction while driving identical specified loads.

2.10 ELECTRICAL CHARACTERISTICS

 $V_{CC1} = V_{CC2} = 3.3\text{ V}^{(1)}$, over recommended operating conditions (unless otherwise noted)

PARAMETER		TEST CONDITIONS		MIN	TYP	MAX	UNIT
I_{CC1}	Supply current, V_{CC1}	ISO7220x	Quiescent	$V_I = V_{CC}$ or 0 V, no load	0.6	1	mA
		ISO7221x			4.3	9.5	
		ISO7220A	1 Mbps		1	2	
		ISO7221A			5	11	
		ISO7221C			25 Mbps	6	
I_{CC2}	Supply current, V_{CC2}	ISO7220x	Quiescent	$V_I = V_{CC}$ or 0 V, no load	8	18	mA
		ISO7221x			4.3	9.5	
		ISO7220A	1 Mbps		9	19	
		ISO7221A			5	11	
		ISO7221C			25 Mbps	6	
V_{OH}	High-level output voltage	$I_{OH} = -4\text{ mA}$, See Figure 2		$V_{CC} - 0.4$	3	V	
		$I_{OH} = -20\text{ }\mu\text{A}$, See Figure 2		$V_{CC} - 0.1$	3.3		
V_{OL}	Low-level output voltage	$I_{OL} = 4\text{ mA}$, See Figure 2			0.2	0.4	V
		$I_{OL} = 20\text{ }\mu\text{A}$, See Figure 2			0	0.1	
$V_{I(HYS)}$	Input voltage hysteresis				150		mV
I_{IH}	High-level input current	IN from 0 V or V_{CC}				10	μA
I_{IL}	Low-level input current	IN from 0 V or V_{CC}		-10			μA
C_I	Input capacitance to ground	IN at V_{CC} , $V_I = 0.4\text{ sin}(4E6\pi t)$			1		pF
CMTI	Common-mode transient immunity	$V_I = V_{CC}$ or 0 V, See Figure 4		15	40		kV/ μs

- (1) For the 5-V operation, V_{CC1} or V_{CC2} is specified from 4.5 V to 5.5 V.
For the 3.3-V operation, V_{CC1} or V_{CC2} is specified from 3 V to 3.6 V.

2.11 SWITCHING CHARACTERISTICS

 $V_{CC1} = V_{CC2} = 3.3\text{ V} \pm 10\%$, over recommended operating conditions (unless otherwise noted)

PARAMETER		TEST CONDITIONS		MIN	TYP	MAX	UNIT
t_{pLH} , t_{pHL}	Propagation delay	ISO722xA	See Figure 2	290	400	610	ns
PWD	Pulse-width distortion $ t_{pHL} - t_{pLH} ^{(1)}$			1	22	ns	
t_{pLH} , t_{pHL}	Propagation delay	ISO722xC	See Figure 2	25	40	52	ns
PWD	Pulse-width distortion $ t_{pHL} - t_{pLH} ^{(1)}$			1	3	ns	
$t_{sk(pp)}$	Part-to-part skew ⁽²⁾	ISO722xA				190	ns
		ISO722xC				10	
$t_{sk(o)}$	Channel-to-channel output skew ⁽³⁾	ISO7220A			3	15	ns
t_r	Output signal rise time	See Figure 2			2		ns
t_f	Output signal fall time	See Figure 2			2		ns
t_{fs}	Failsafe output delay time from input power loss	See Figure 3			3		μs

- (1) Also referred to as pulse skew.
(2) $t_{sk(pp)}$ is the magnitude of the difference in propagation delay times between any specified terminals of two devices when both devices operate with the same supply voltages, at the same temperature, and have identical packages and test circuits.
(3) $t_{sk(o)}$ is the skew between specified outputs of a single device with all driving inputs connected together and the outputs switching in the same direction while driving identical specified loads.

3 PARAMETER MEASUREMENT INFORMATION

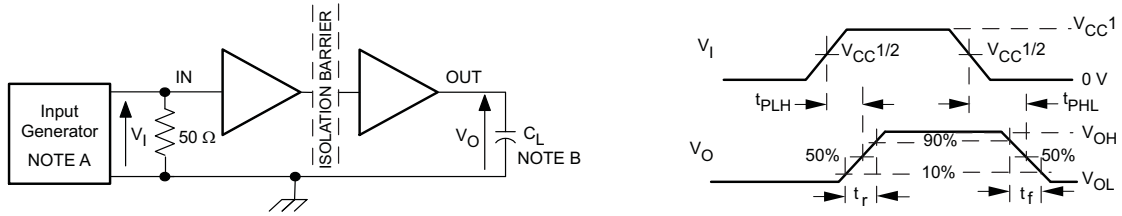

- A. The input pulse is supplied by a generator having the following characteristics: PRR \leq 50 kHz, 50% duty cycle, $t_r \leq$ 3 ns, $t_f \leq$ 3 ns, $Z_O = 50\Omega$.
- B. $C_L = 15$ pF and includes instrumentation and fixture capacitance within $\pm 20\%$.

Figure 2. Switching Characteristic Test Circuit and Voltage Waveforms

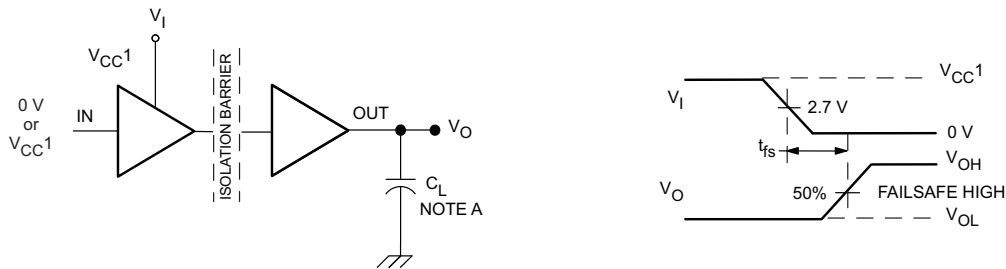

- A. $C_L = 15$ pF and includes instrumentation and fixture capacitance within $\pm 20\%$.

Figure 3. Failsafe Delay Time Test Circuit and Voltage Waveforms

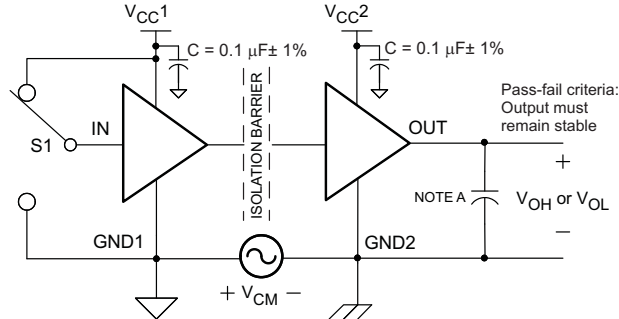

- A. $C_L = 15$ pF and includes instrumentation and fixture capacitance within $\pm 20\%$.

Figure 4. Common-Mode Transient Immunity Test Circuit

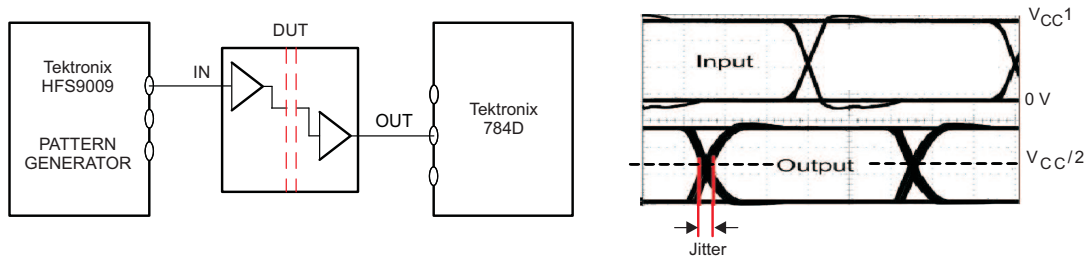

NOTE: PRBS bit pattern run length is $2^{16} - 1$. Transition time is 800 ps.

Figure 5. Peak-to-Peak Eye-Pattern Jitter Test Circuit and Voltage Waveform

4 DEVICE INFORMATION

4.1 IEC PACKAGE CHARACTERISTICS

PARAMETER		TEST CONDITIONS	MIN	TYP	MAX	UNIT
L(I01)	Minimum air gap (clearance)	Shortest terminal-to-terminal distance through air	4.8			mm
L(I02)	Minimum external tracking (creepage)	Shortest terminal-to-terminal distance across the package surface				
CTI	Tracking resistance (comparative tracking index)	DIN EN 60112 (VDE 0303-11)	≥175			V
	Minimum internal gap (internal clearance)	Distance through the insulation	0.008			mm
R _{IO}	Isolation resistance	Input to output, V _{IO} = 500 V, all pins on each side of the barrier tied together creating a two-terminal device, T _A < 100°C	>10 ¹²			Ω
		Input to output, V _{IO} = 500 V, 100°C ≤ T _A ≤ max	>10 ¹¹			Ω
C _{IO}	Barrier capacitance input to output	V _I = 0.4 sin (4E6πt)	1			pF
C _I	Input capacitance to ground	V _I = 0.4 sin (4E6πt)	1			pF

NOTE: Creepage and clearance requirements should be applied according to the specific equipment isolation standards of an application. Care should be taken to maintain the creepage and clearance distance of a board design to ensure that the mounting pads of the isolator on the printed circuit board do not reduce this distance.

Creepage and clearance on a printed circuit board become equal according to the measurement techniques shown in the [Isolation Glossary](#). Techniques such as inserting grooves and/or ribs on a printed circuit board are used to help increase these specifications.

4.2 IEC 60664-1 RATINGS TABLE

PARAMETER	TEST CONDITIONS	SPECIFICATION
Basic isolation group	Material group	IIIa
Installation classification	Rated mains voltage ≤150 V _{RMS}	I-IV
	Rated mains voltage ≤300 V _{RMS}	I-III
	Rated mains voltage ≤400 V _{RMS}	I-II

4.3 INSULATION CHARACTERISTICS⁽¹⁾

PARAMETER	TEST CONDITIONS	SPECIFICATION	UNIT
V _{IORM}	Maximum working insulation voltage	560	V _{PK}
V _{PR}	Input to output test voltage	Method b1, V _{PR} = V _{IORM} × 1.875, 100% Production test with t = 1 s, Partial discharge <5 pC	1050 V _{PK}
V _{IOTM}	Transient overvoltage	t = 60 s	4000 V _{PK}
R _S	Insulation resistance	V _{IO} = 500 V at T _S	>10 ⁹ Ω
	Pollution degree		2
V _{ISO}	Maximum withstanding isolation voltage	V _{TEST} = 2500 V _{RMS} , t = 60 s (qualification), V _{TEST} = 3000 V _{RMS} , t = 1 s (100% production)	2500 V _{RMS}

(1) Climatic Classification 40/125/21

4.4 DEVICE I/O SCHEMATICS

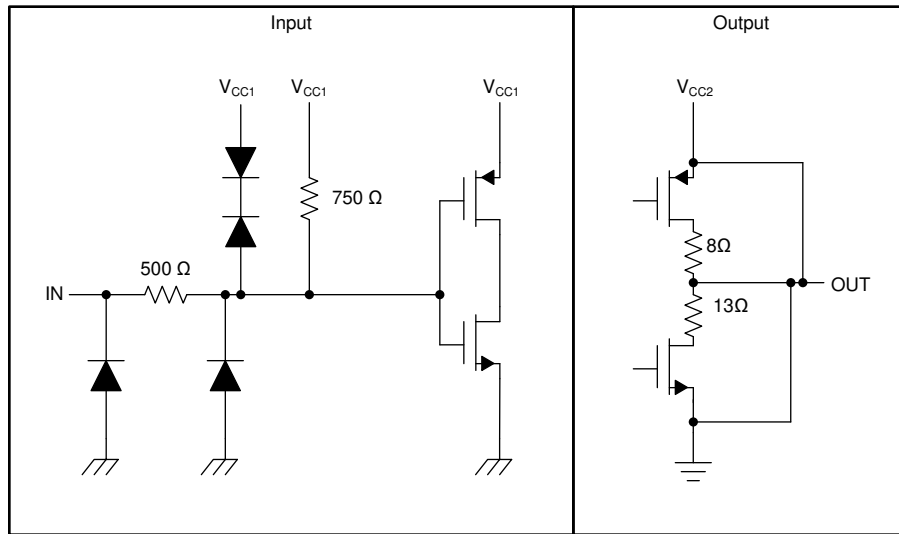

4.5 IEC SAFETY LIMITING VALUES

Safety limiting intends to prevent potential damage to the isolation barrier upon failure of input or output circuitry. A failure of the IO can allow low resistance to ground or the supply and, without current limiting, dissipate sufficient power to overheat the die and damage the isolation barrier potentially leading to secondary system failures.

PARAMETER		TEST CONDITIONS		MIN	MAX	UNIT
I_S	Safety input, output, or supply current	SOIC-8	$\theta_{JA} = 212^\circ\text{C/W}$, $V_I = 5.5\text{ V}$, $T_J = 170^\circ\text{C}$, $T_A = 25^\circ\text{C}$		124	mA
			$\theta_{JA} = 212^\circ\text{C/W}$, $V_I = 3.6\text{ V}$, $T_J = 170^\circ\text{C}$, $T_A = 25^\circ\text{C}$		190	
T_S	Maximum case temperature	SOIC-8			150	$^\circ\text{C}$

The safety-limiting constraint is the absolute maximum junction temperature specified in the absolute maximum ratings table. The power dissipation and junction-to-air thermal impedance of the device installed in the application hardware determines the junction temperature. The assumed junction-to-air thermal resistance in the Thermal Characteristics table is that of a device installed in the JESD51-3, Low Effective Thermal Conductivity Test Board for Leaded Surface Mount Packages and is conservative. The power is the recommended maximum input voltage times the current. The junction temperature is then the ambient temperature plus the power times the junction-to-air thermal resistance.

4.6 SOIC-8 PACKAGE THERMAL CHARACTERISTICS

over recommended operating conditions (unless otherwise noted)

PARAMETER		TEST CONDITIONS	MIN	TYP	MAX	UNIT
θ_{JA}	Junction-to-air thermal resistance	Low-K thermal resistance ⁽¹⁾		212		°C/W
		High-K thermal resistance		122		
θ_{JB}	Junction-to-board thermal resistance			37		°C/W
θ_{JC}	Junction-to-case thermal resistance			69.1		°C/W

(1) Tested in accordance with the Low-K or High-K thermal metric definitions of EIA/JESD51-3 for leaded surface mount packages.

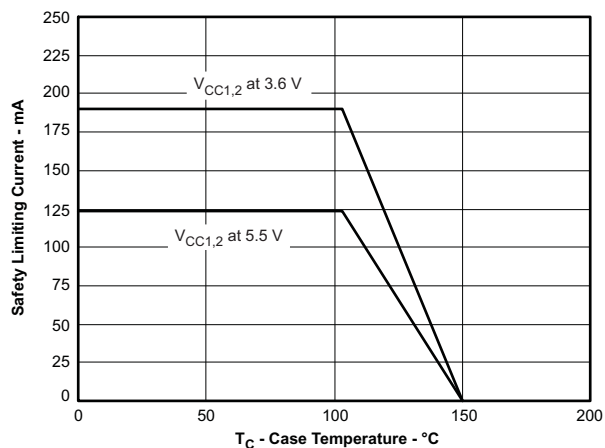

Figure 6. SOIC-8 THERMAL DERATING CURVE

4.7 DEVICE FUNCTION TABLE

Table 2. ISO7220x or ISO7221x⁽¹⁾

INPUT SIDE V_{CC}	OUTPUT SIDE V_{CC}	INPUT IN	OUTPUT OUT
PU	PU	H	H
		L	L
		Open	H
PD	PU	X	H

(1) PU = Powered up ($V_{CC} \geq 3.0$ V), PD = Powered down ($V_{CC} \leq 2.5$ V), X = Irrelevant, H = High level, L = Low level

5 TYPICAL CHARACTERISTIC CURVES

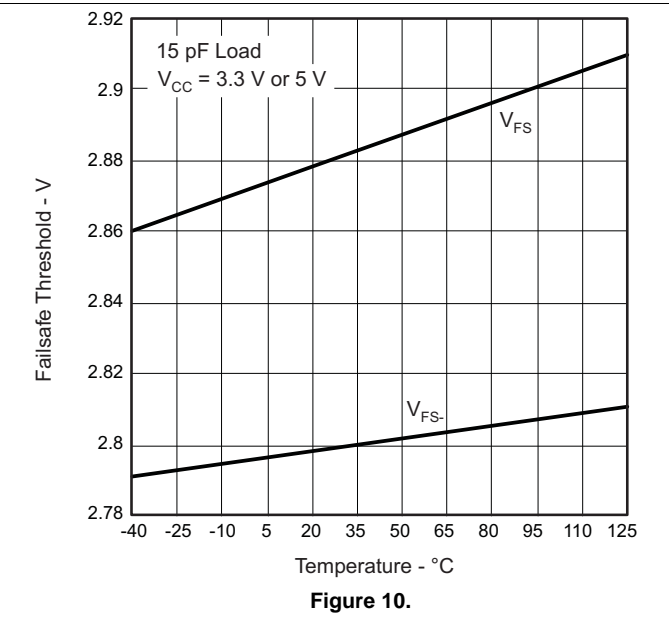
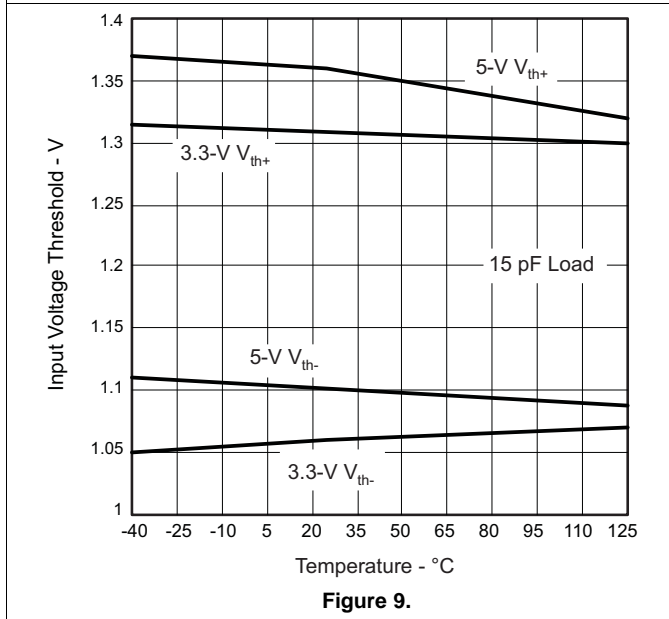
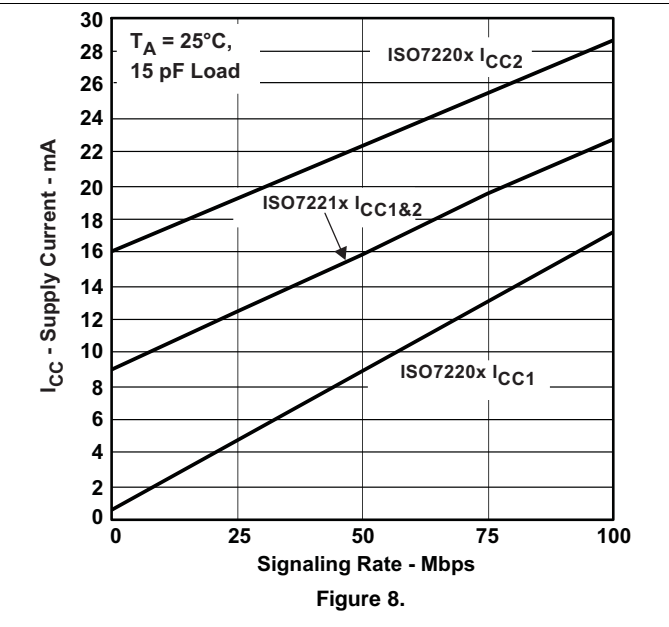
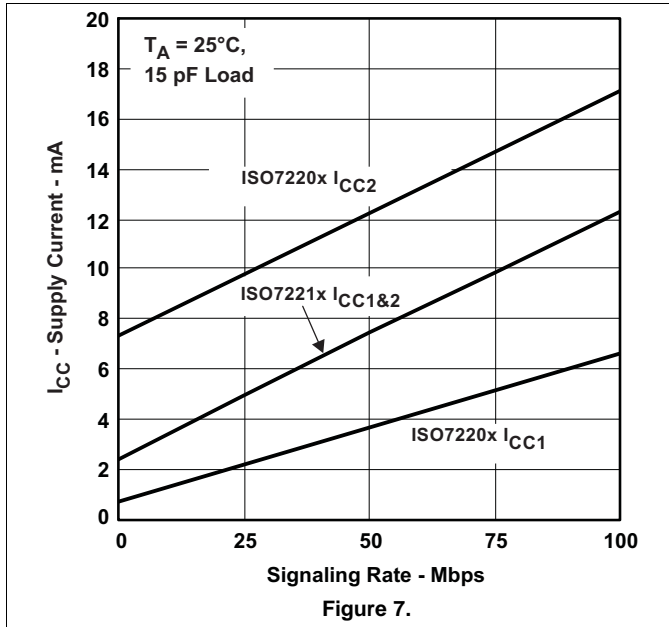

TYPICAL CHARACTERISTIC CURVES (continued)

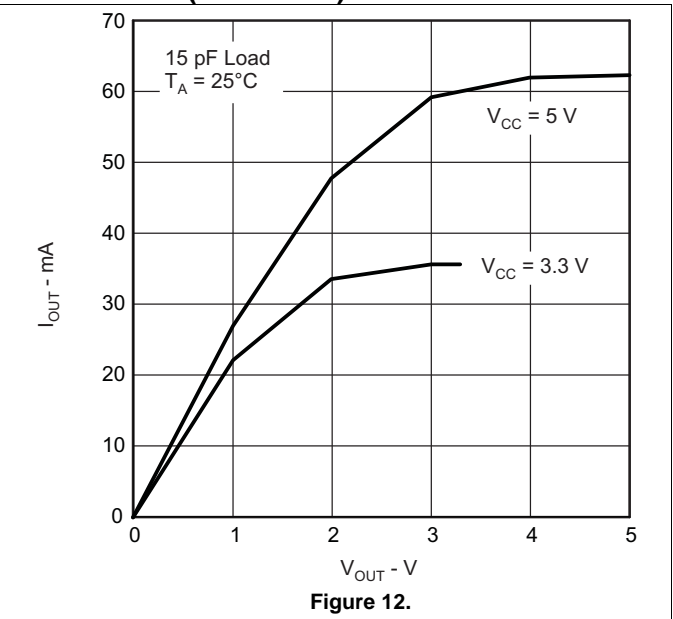
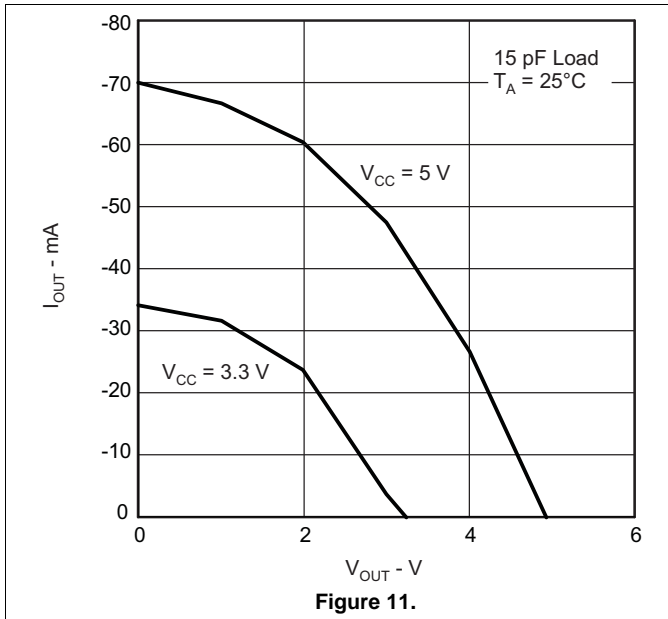

6 APPLICATION INFORMATION

6.1 Typical Applications

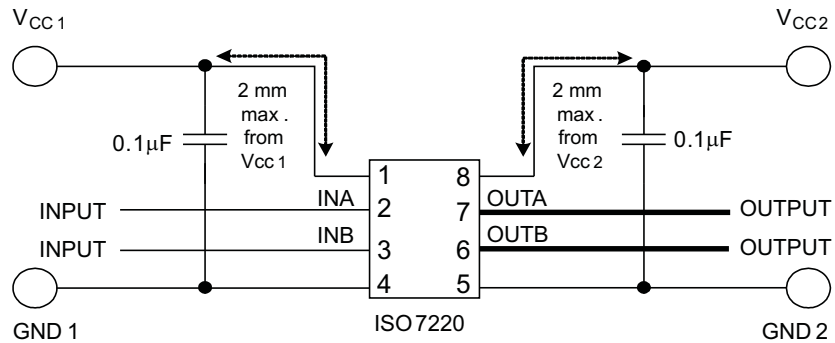

Figure 13. Typical ISO7220 Application Circuit

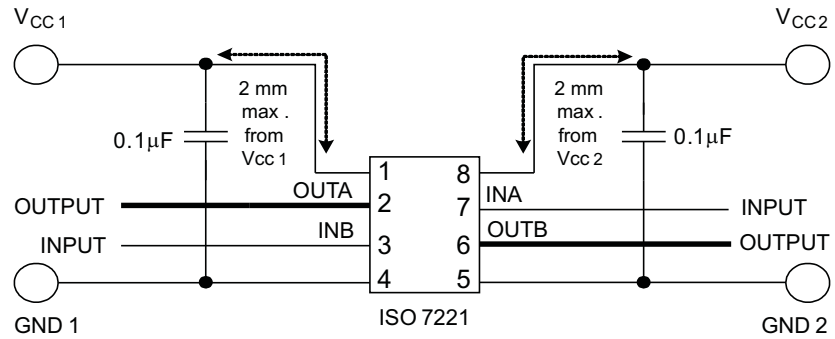

Figure 14. Typical ISO7221 Application Circuit

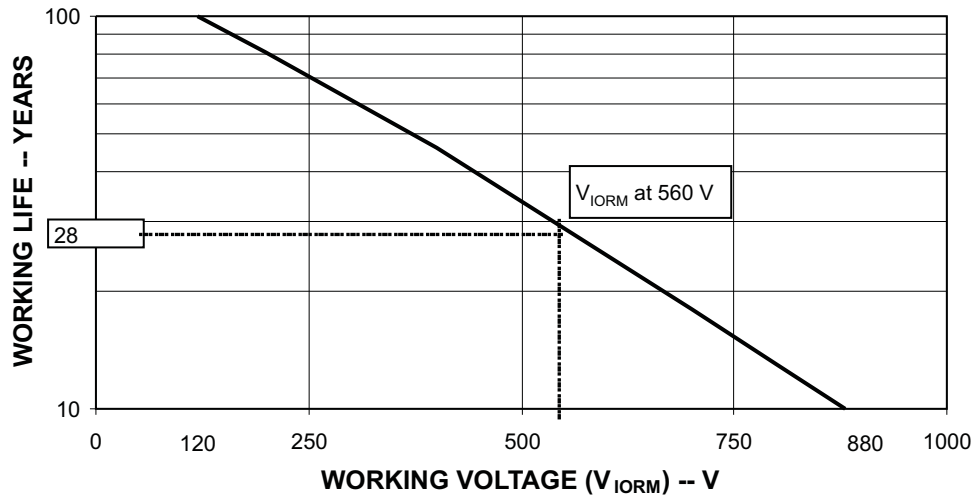
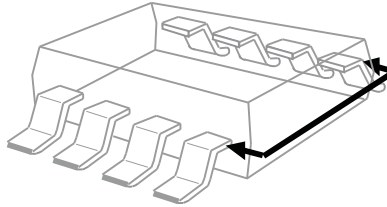

Figure 15. Time-Dependent Dielectric Breakdown Test Results

7 ISOLATION GLOSSARY

Creepage Distance — The shortest path between two conductive input to output leads measured along the surface of the insulation. The shortest distance path is found around the end of the package body.



Clearance — The shortest distance between two conductive input to output leads measured through air (line of sight).

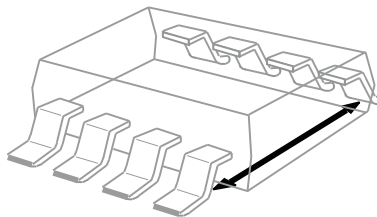

Input-to Output Barrier Capacitance — The total capacitance between all input terminals connected together, and all output terminals connected together.

Input-to Output Barrier Resistance — The total resistance between all input terminals connected together, and all output terminals connected together.

Primary Circuit — An internal circuit directly connected to an external supply mains or other equivalent source which supplies the primary circuit electric power.

Secondary Circuit — A circuit with no direct connection to primary power, and derives its power from a separate isolated source.

Comparative Tracking Index (CTI) — CTI is an index used for electrical insulating materials which is defined as the numerical value of the voltage which causes failure by tracking during standard testing. Tracking is the process that produces a partially conducting path of localized deterioration on or through the surface of an insulating material as a result of the action of electric discharges on or close to an insulation surface -- the higher CTI value of the insulating material, the smaller the minimum creepage distance.

Generally, insulation breakdown occurs either through the material, over its surface, or both. Surface failure may arise from flashover or from the progressive degradation of the insulation surface by small localized sparks. Such sparks are the result of the breaking of a surface film of conducting contaminant on the insulation. The resulting break in the leakage current produces an overvoltage at the site of the discontinuity, and an electric spark is generated. These sparks often cause carbonization on insulation material and lead to a carbon track between points of different potential. This process is known as *tracking*.

7.0.1 Insulation:

Operational insulation — Insulation needed for the correct operation of the equipment.

Basic insulation — Insulation to provide basic protection against electric shock.

Supplementary insulation — Independent insulation applied in addition to basic insulation in order to ensure protection against electric shock in the event of a failure of the basic insulation.

Double insulation — Insulation comprising both basic and supplementary insulation.

Reinforced insulation — A single insulation system which provides a degree of protection against electric shock equivalent to double insulation.

7.0.2 Pollution Degree:

Pollution Degree 1 — No pollution, or only dry, nonconductive pollution occurs. The pollution has no influence.

Pollution Degree 2 — Normally, only nonconductive pollution occurs. However, a temporary conductivity caused by condensation must be expected.

Pollution Degree 3 — Conductive pollution occurs or dry nonconductive pollution occurs which becomes conductive due to condensation which is to be expected.

Pollution Degree 4 — Continuous conductivity occurs due to conductive dust, rain, or other wet conditions.

7.0.3 Installation Category:

Overvoltage Category — This section is directed at insulation co-ordination by identifying the transient overvoltages which may occur, and by assigning 4 different levels as indicated in IEC 60664.

I: Signal Level — Special equipment or parts of equipment.

II: Local Level — Portable equipment etc.

III: Distribution Level — Fixed installation

IV: Primary Supply Level — Overhead lines, cable systems

Each category should be subject to smaller transients than the category above.

8 REVISION HISTORY

NOTE: Page numbers for previous revisions may differ from page numbers in the current version.

Changes from Revision B (March 2010) to Revision C	Page
• Added storage temperature to Abs Max table.....	3

Changes from Revision C (May 2012) to Revision D	Page
• Made editorial and cosmetic changes throughout the document	1
• Change standard names From: 'IEC 60747-5-2 (VDE 0884, Rev 2), IEC 61010-1' To: 'DIN VDE V 0884-11:2017-01, DIN EN 61010-1' and add 'IEC 62368-1' in FEATURES	1
• Updated REGULATORY INFORMATION table	2
• Changed V_I voltage rating From: '-0.5 V to 6 V' To: '-0.5 V to $V_{CC} + 0.5 V$ ' in ABSOLUTE MAXIMUM RATINGS table	3
• Added the following note to V_I parameter: 'Maximum voltage must not exceed 6V' in ABSOLUTE MAXIMUM RATINGS table.....	3
• Deleted typical values (TYP) for 'Input pulse width' and 'Signaling rate' specifications in RECOMMENDED OPERATING CONDITIONS table.....	3
• Added 'Ambient temperature' specification in RECOMMENDED OPERATING CONDITIONS table	3
• Changed 'Propagation delay' maximum (MAX) limit for ISO722xA From: 480 ns To: 600 ns in SWITCHING CHARACTERISTICS at $V_{CC1} = V_{CC2} = 5 V \pm 10\%$	4
• Changed 'Pulse-width distortion' maximum (MAX) limit for ISO722xA From: 14 ns To: 18 ns in SWITCHING CHARACTERISTICS at $V_{CC1} = V_{CC2} = 5 V \pm 10\%$	4
• Changed 'ISO722xA' to 'ISO7220A' and deleted 'ISO722xC' row from 'Channel-to-channel output skew' specification in SWITCHING CHARACTERISTICS at $V_{CC1} = V_{CC2} = 5 V \pm 10\%$	4
• Changed 'Propagation delay' maximum (MAX) limit for ISO722xA From: 480 ns To: 585 ns in SWITCHING CHARACTERISTICS at $V_{CC1} = 5 V \pm 10\%$, $V_{CC2} = 3.3 V \pm 10\%$	5
• Changed 'Pulse-width distortion' maximum (MAX) limit for ISO722xA From: 14 ns To: 18 ns in SWITCHING CHARACTERISTICS at $V_{CC1} = 5 V \pm 10\%$, $V_{CC2} = 3.3 V \pm 10\%$	5
• Changed 'ISO722xA' to 'ISO7220A' and deleted 'ISO722xC' row from 'Channel-to-channel output skew' specification in SWITCHING CHARACTERISTICS at $V_{CC1} = 5 V \pm 10\%$, $V_{CC2} = 3.3 V \pm 10\%$	5
• Changed 'Propagation delay' maximum (MAX) limit for ISO722xA From: 480 ns To: 605 ns in SWITCHING CHARACTERISTICS at $V_{CC1} = 3.3 V \pm 10\%$, $V_{CC2} = 5 V \pm 10\%$	6
• Changed 'Pulse-width distortion' maximum (MAX) limit for ISO722xA From: 18 ns To: 22 ns in SWITCHING CHARACTERISTICS at $V_{CC1} = 3.3 V \pm 10\%$, $V_{CC2} = 5 V \pm 10\%$	6
• Changed 'ISO722xA' to 'ISO7220A' and deleted 'ISO722xC' row from 'Channel-to-channel output skew' specification in SWITCHING CHARACTERISTICS at $V_{CC1} = 3.3 V \pm 10\%$, $V_{CC2} = 5 V \pm 10\%$	6
• Changed 'Propagation delay' maximum (MAX) limit for ISO722xA From: 485 ns To: 610 ns in SWITCHING CHARACTERISTICS at $V_{CC1} = V_{CC2} = 3.3 V \pm 10\%$	7
• Changed 'Pulse-width distortion' maximum (MAX) limit for ISO722xA From: 18 ns To: 22 ns in SWITCHING CHARACTERISTICS at $V_{CC1} = V_{CC2} = 3.3 V \pm 10\%$	7
• Changed 'ISO722xA' to 'ISO7220A' and deleted 'ISO722xC' row from 'Channel-to-channel output skew' specification in SWITCHING CHARACTERISTICS at $V_{CC1} = V_{CC2} = 3.3 V \pm 10\%$	7
• Changed 'Tracking resistance' TEST CONDITIONS From: DIN IEC 60112 / VDE 0303 Part 1 To: DIN EN 60112 (VDE 0303-11) in IEC PACKAGE CHARACTERISTICS table	9
• Deleted 'IEC 60747-5-2' from INSULATIONS CHARACTERISTICS table title.....	9
• Added 'Maximum withstanding isolation voltage' specification of $2500 V_{RMS}$ in INSULATION CHARACTERISTICS table	9
• Deleted ' θ_{JC} ' and 'per IEC 60747-5-2' from Figure 6 title.	11

PACKAGING INFORMATION

Orderable Device	Status (1)	Package Type	Package Drawing	Pins	Package Qty	Eco Plan (2)	Lead finish/ Ball material (6)	MSL Peak Temp (3)	Op Temp (°C)	Device Marking (4/5)	Samples
ISO7220AQDRQ1	ACTIVE	SOIC	D	8	2500	RoHS & Green	NIPDAU	Level-3-260C-168 HR	-40 to 125	7220AQ	Samples
ISO7221AQDRQ1	ACTIVE	SOIC	D	8	2500	RoHS & Green	NIPDAU	Level-3-260C-168 HR	-40 to 125	7221AQ	Samples
ISO7221CQDRQ1	ACTIVE	SOIC	D	8	2500	RoHS & Green	NIPDAU	Level-3-260C-168 HR	-40 to 125	7221CQ	Samples

(1) The marketing status values are defined as follows:

ACTIVE: Product device recommended for new designs.

LIFEBUY: TI has announced that the device will be discontinued, and a lifetime-buy period is in effect.

NRND: Not recommended for new designs. Device is in production to support existing customers, but TI does not recommend using this part in a new design.

PREVIEW: Device has been announced but is not in production. Samples may or may not be available.

OBSOLETE: TI has discontinued the production of the device.

(2) **RoHS:** TI defines "RoHS" to mean semiconductor products that are compliant with the current EU RoHS requirements for all 10 RoHS substances, including the requirement that RoHS substance do not exceed 0.1% by weight in homogeneous materials. Where designed to be soldered at high temperatures, "RoHS" products are suitable for use in specified lead-free processes. TI may reference these types of products as "Pb-Free".

RoHS Exempt: TI defines "RoHS Exempt" to mean products that contain lead but are compliant with EU RoHS pursuant to a specific EU RoHS exemption.

Green: TI defines "Green" to mean the content of Chlorine (Cl) and Bromine (Br) based flame retardants meet JS709B low halogen requirements of <=1000ppm threshold. Antimony trioxide based flame retardants must also meet the <=1000ppm threshold requirement.

(3) MSL, Peak Temp. - The Moisture Sensitivity Level rating according to the JEDEC industry standard classifications, and peak solder temperature.

(4) There may be additional marking, which relates to the logo, the lot trace code information, or the environmental category on the device.

(5) Multiple Device Markings will be inside parentheses. Only one Device Marking contained in parentheses and separated by a "~" will appear on a device. If a line is indented then it is a continuation of the previous line and the two combined represent the entire Device Marking for that device.

(6) Lead finish/Ball material - Orderable Devices may have multiple material finish options. Finish options are separated by a vertical ruled line. Lead finish/Ball material values may wrap to two lines if the finish value exceeds the maximum column width.

Important Information and Disclaimer:The information provided on this page represents TI's knowledge and belief as of the date that it is provided. TI bases its knowledge and belief on information provided by third parties, and makes no representation or warranty as to the accuracy of such information. Efforts are underway to better integrate information from third parties. TI has taken and continues to take reasonable steps to provide representative and accurate information but may not have conducted destructive testing or chemical analysis on incoming materials and chemicals. TI and TI suppliers consider certain information to be proprietary, and thus CAS numbers and other limited information may not be available for release.

In no event shall TI's liability arising out of such information exceed the total purchase price of the TI part(s) at issue in this document sold by TI to Customer on an annual basis.

OTHER QUALIFIED VERSIONS OF ISO7220A-Q1, ISO7221A-Q1, ISO7221C-Q1 :

- Catalog: [ISO7220A](#), [ISO7221A](#), [ISO7221C](#)

NOTE: Qualified Version Definitions:

- Catalog - TI's standard catalog product

TAPE AND REEL INFORMATION

QUADRANT ASSIGNMENTS FOR PIN 1 ORIENTATION IN TAPE

*All dimensions are nominal

Device	Package Type	Package Drawing	Pins	SPQ	Reel Diameter (mm)	Reel Width W1 (mm)	A0 (mm)	B0 (mm)	K0 (mm)	P1 (mm)	W (mm)	Pin1 Quadrant
ISO7220AQDRQ1	SOIC	D	8	2500	330.0	12.4	6.4	5.2	2.1	8.0	12.0	Q1
ISO7221AQDRQ1	SOIC	D	8	2500	330.0	12.4	6.4	5.2	2.1	8.0	12.0	Q1
ISO7221CQDRQ1	SOIC	D	8	2500	330.0	12.4	6.4	5.2	2.1	8.0	12.0	Q1

TAPE AND REEL BOX DIMENSIONS

*All dimensions are nominal

Device	Package Type	Package Drawing	Pins	SPQ	Length (mm)	Width (mm)	Height (mm)
ISO7220AQDRQ1	SOIC	D	8	2500	350.0	350.0	43.0
ISO7221AQDRQ1	SOIC	D	8	2500	350.0	350.0	43.0
ISO7221CQDRQ1	SOIC	D	8	2500	350.0	350.0	43.0

EXAMPLE BOARD LAYOUT

D0008A

SOIC - 1.75 mm max height

SMALL OUTLINE INTEGRATED CIRCUIT



LAND PATTERN EXAMPLE
 EXPOSED METAL SHOWN
 SCALE:8X



SOLDER MASK DETAILS

4214825/C 02/2019

NOTES: (continued)

- 6. Publication IPC-7351 may have alternate designs.
- 7. Solder mask tolerances between and around signal pads can vary based on board fabrication site.

EXAMPLE STENCIL DESIGN

D0008A

SOIC - 1.75 mm max height

SMALL OUTLINE INTEGRATED CIRCUIT



SOLDER PASTE EXAMPLE
BASED ON .005 INCH [0.125 MM] THICK STENCIL
SCALE:8X

4214825/C 02/2019

NOTES: (continued)

8. Laser cutting apertures with trapezoidal walls and rounded corners may offer better paste release. IPC-7525 may have alternate design recommendations.
9. Board assembly site may have different recommendations for stencil design.

IMPORTANT NOTICE AND DISCLAIMER

TI PROVIDES TECHNICAL AND RELIABILITY DATA (INCLUDING DATA SHEETS), DESIGN RESOURCES (INCLUDING REFERENCE DESIGNS), APPLICATION OR OTHER DESIGN ADVICE, WEB TOOLS, SAFETY INFORMATION, AND OTHER RESOURCES "AS IS" AND WITH ALL FAULTS, AND DISCLAIMS ALL WARRANTIES, EXPRESS AND IMPLIED, INCLUDING WITHOUT LIMITATION ANY IMPLIED WARRANTIES OF MERCHANTABILITY, FITNESS FOR A PARTICULAR PURPOSE OR NON-INFRINGEMENT OF THIRD PARTY INTELLECTUAL PROPERTY RIGHTS.

These resources are intended for skilled developers designing with TI products. You are solely responsible for (1) selecting the appropriate TI products for your application, (2) designing, validating and testing your application, and (3) ensuring your application meets applicable standards, and any other safety, security, regulatory or other requirements.

These resources are subject to change without notice. TI grants you permission to use these resources only for development of an application that uses the TI products described in the resource. Other reproduction and display of these resources is prohibited. No license is granted to any other TI intellectual property right or to any third party intellectual property right. TI disclaims responsibility for, and you will fully indemnify TI and its representatives against, any claims, damages, costs, losses, and liabilities arising out of your use of these resources.

TI's products are provided subject to [TI's Terms of Sale](#) or other applicable terms available either on [ti.com](https://www.ti.com) or provided in conjunction with such TI products. TI's provision of these resources does not expand or otherwise alter TI's applicable warranties or warranty disclaimers for TI products.

TI objects to and rejects any additional or different terms you may have proposed.

Mailing Address: Texas Instruments, Post Office Box 655303, Dallas, Texas 75265
Copyright © 2023, Texas Instruments Incorporated

Looking for pricing, stock, or lifecycle information?

Click below to explore more details on WIN SOURCE:

 [View ISO7221CQDRQ1](#) on WIN SOURCE

 [Texas Instruments](#) Information

Optimize Your Supply Chain with WIN SOURCE Solutions

-  Global Sourcing Solution
-  Obsolete Management
-  Cost Control Management
-  Shortage Management
-  Alternative Solution
-  Excess Inventory Management