



**THE DATASHEET OF
DRV8823QDCARQ1**



DRV8823-Q1 4-Bridge Serial Interface Motor Driver

1 Features

- Qualified for Automotive Applications
- AEC-Q100 Qualified with the Following Results:
 - Device Temperature Grade 1: –40°C to 125°C Ambient Operating Temperature Range
 - Device HBM ESD Classification Level H2
 - Device CDM ESD Classification Level C4B
- PWM Motor Driver with Four H-Bridges
 - Drives Two Stepper Motors, One Stepper and Two DC Motors, or Four DC Motors
 - Up to 1.5-A Current Per Winding
 - Low On-Resistance
 - Programmable Maximum Winding Current
 - Three-Bit Winding Current Control Allows up to Eight Current Levels
 - Selectable Slow or Mixed Decay Modes
- 8-V to 32-V Operating Supply Voltage Range
- Internal Charge Pump for Gate Drive
- Built-in 3.3-V Reference
- Serial Digital Control Interface
- Fully Protected Against Undervoltage, Overtemperature, and Overcurrent
- Thermally-Enhanced Surface Mount Package

2 Applications

Automotive

3 Description

The DRV8823-Q1 device provides an integrated motor driver solution for printers and other office automation equipment applications.

The motor driver circuit includes four H-bridge drivers. Each of the motor driver blocks employ N-channel power MOSFETs configured as an H-bridge to drive the motor windings.

A simple serial interface allows control of all functions of the motor driver with only a few digital signals. A low-power sleep function is also provided.

The motor drivers provide PWM current control capability. The current is programmable, based on an externally supplied reference voltage and an external current sense resistor. In addition, eight current levels (set through the serial interface) allow microstepping with bipolar stepper motors.

Internal shutdown functions are provided for overcurrent protection, short-circuit protection, undervoltage lockout, and overtemperature.

The DRV8823-Q1 is packaged in a 48-pin HTSSOP package (Eco-friendly: RoHS and no Sb/Br).

Device Information⁽¹⁾

PART NUMBER	PACKAGE	BODY SIZE (NOM)
DRV8823-Q1	HTSSOP (48)	12.50 mm x 6.10 mm

(1) For all available packages, see the orderable addendum at the end of the data sheet.

Simplified Schematic

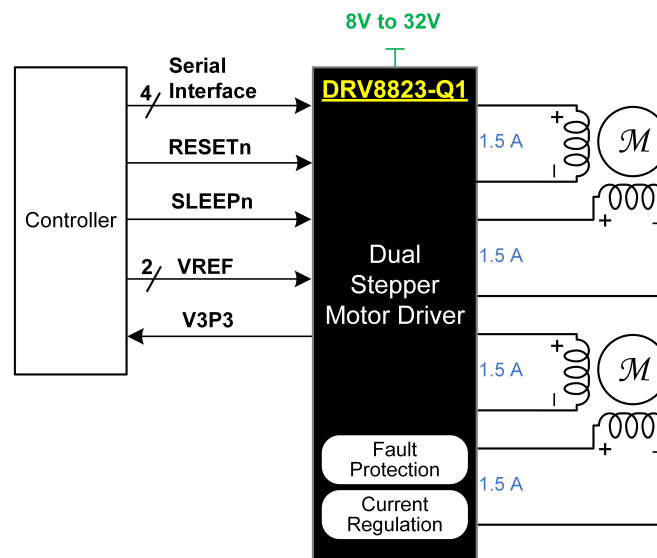

Table of Contents

1 Features 1 2 Applications 1 3 Description 1 4 Revision History 2 5 Pin Configuration and Functions 3 6 Specifications 5 6.1 Absolute Maximum Ratings 5 6.2 ESD Ratings 5 6.3 Recommended Operating Conditions 5 6.4 Thermal Information 5 6.5 Electrical Characteristics 6 6.6 Timing Requirements 6 6.7 Dissipation Ratings 7 6.8 Typical Characteristics 7 7 Detailed Description 9 7.1 Overview 9 7.2 Functional Block Diagram 10 7.3 Feature Description 11	7.4 Device Functional Modes 12 7.5 Programming 14 8 Application and Implementation 16 8.1 Application Information 16 8.2 Typical Application 16 9 Power Supply Recommendations 19 10 Layout 19 10.1 Layout Guidelines 19 10.2 Layout Example 20 10.3 Thermal Considerations 20 11 Device and Documentation Support 22 11.1 Documentation Support 22 11.2 Community Resources 22 11.3 Trademarks 22 11.4 Electrostatic Discharge Caution 22 11.5 Glossary 22 12 Mechanical, Packaging, and Orderable Information 22
---	---

4 Revision History

NOTE: Page numbers for previous revisions may differ from page numbers in the current version.

Changes from Revision B (January 2013) to Revision C	Page
<ul style="list-style-type: none"> • Added <i>ESD Ratings</i> table, <i>Feature Description</i> section, <i>Device Functional Modes</i>, <i>Application and Implementation</i> section, <i>Power Supply Recommendations</i> section, <i>Layout</i> section, <i>Device and Documentation Support</i> section, and <i>Mechanical, Packaging, and Orderable Information</i> section 	5

Changes from Original (June 2012) to Revision A	Page
<ul style="list-style-type: none"> • Updated electrical characteristics table 	6

5 Pin Configuration and Functions

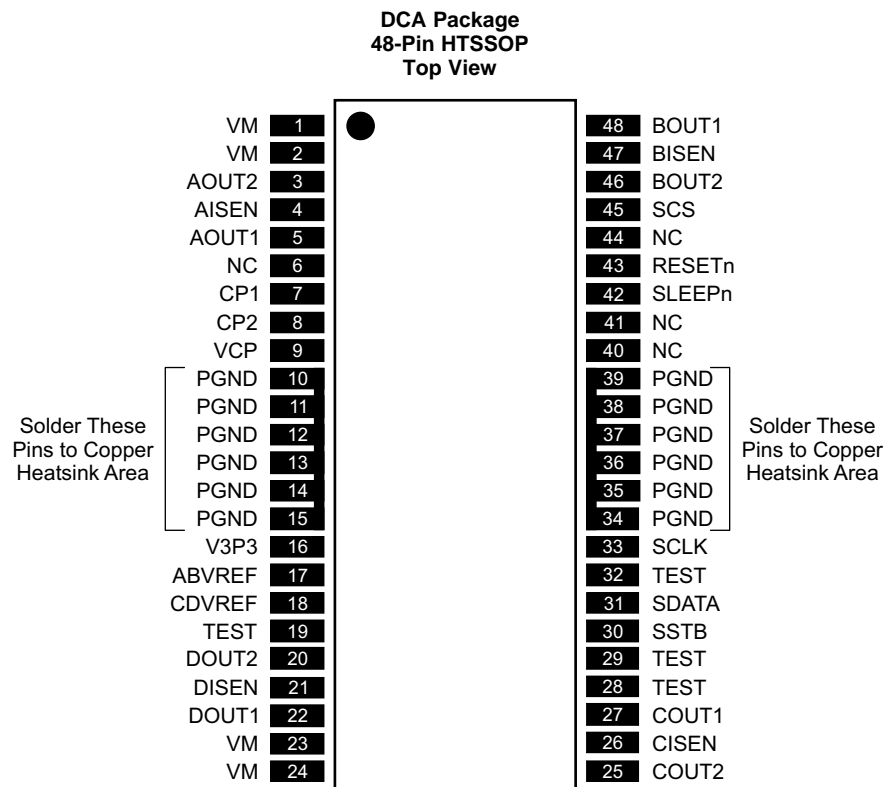

Pin Functions

PIN		I/O ⁽¹⁾	DESCRIPTION	EXTERNAL COMPONENTS OR CONNECTIONS
NAME	NO.			
POWER AND GROUND				
VM	1, 2, 23, 24	–	Motor supply voltage (multiple pins)	Connect all VM pins together to motor supply voltage. Bypass to GND with several 0.1- μ F, 35-V ceramic capacitors.
V3P3	16	–	3.3 V regulator output	Bypass to GND with 0.47- μ F, 6.3-V ceramic capacitor.
GND	10–15, 34–39	–	Power ground (multiple pins)	Connect all PGND pins to GND and solder to copper heatsink areas.
CP1	7	IO	Charge pump flying capacitor	Connect a 0.01- μ F capacitor between CP1 and CP2.
CP2	8	IO		
VCP	9	IO	Charge pump storage capacitor	Connect a 0.1- μ F, 16 V ceramic capacitor to V _M .
MOTOR DRIVERS				
ABVREF	17	I	Bridge A & B current set reference voltage	Sets current trip threshold
AOUT1	5	O	Bridge A output 1	Connect to first coil of bipolar stepper motor 1, or DC motor winding.
AOUT2	3	O	Bridge A output 2	
ISENA	4	–	Bridge A current sense	Connect to current sense resistor for bridge A.
BOUT1	48	O	Bridge B output 1	Connect to second coil of bipolar stepper motor 1, or DC motor winding.
BOUT2	46	O	Bridge B output 2	
ISENB	47	–	Bridge B current sense	Connect to current sense resistor for bridge B.
CDVREF	18	I	Bridge C & D current set reference voltage	Sets current trip threshold
COU1	27	O	Bridge C output 1	Connect to first coil of bipolar stepper motor 2, or DC motor winding.
COU2	25	O	Bridge C output 2	
ISENC	26	–	Bridge C current sense	Connect to current sense resistor for bridge C.
DOUT1	22	O	Bridge D output 1	Connect to second coil of bipolar stepper motor 2, or DC motor winding.
DOUT2	20	O	Bridge D output 2	
ISEND	22	–	Bridge D current sense	Connect to current sense resistor for bridge D.
SERIAL INTERFACE				
SDATA	31	I	Serial data input	Data is clocked in on rising edge of SCLK.
SCLK	33	I	Serial input clock	Logic high enables serial data to be clocked in.
SCS	45	I	Serial chip select	Logic high latches serial data.
SSTB	30	I	Serial data strobe	Active low resets serial interface and disables outputs.
RESETn	43	I	Reset input	Active low input disables outputs and charge pump.
SLEEPn	42	I	Sleep input	
TEST PINS				
TEST	19, 28, 29, 32	I	Test inputs	Do not connect these pins - used for factory test only.

(1) Directions: I = input, O = output, OZ = 3-state output, OD = open-drain output, IO = input/output, PU = internal pullup

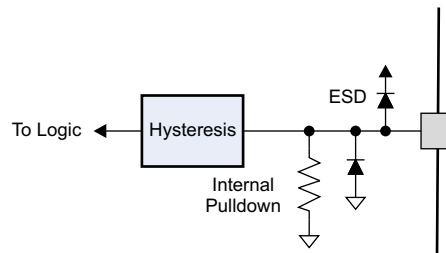

Figure 1. Logic Inputs

6 Specifications

6.1 Absolute Maximum Ratings

over operating free-air temperature range (unless otherwise noted)⁽¹⁾⁽²⁾

		MIN	MAX	UNIT
V _M	Power supply voltage	-0.3	34	V
V _I	Logic input voltage ⁽³⁾	-0.5	5.75	V
I _{O(peak)}	Peak motor drive output current, t < 1 μs	Internally limited		
I _O	Motor drive output current ⁽⁴⁾	1.5		A
P _D	Continuous total power dissipation	See Dissipation Ratings		
T _A	Operating ambient temperature	-40	125	°C
T _J	Operating virtual junction temperature	-40	150	°C
T _{stg}	Storage temperature	-60	150	°C

- (1) Stresses beyond those listed under *absolute maximum ratings* may cause permanent damage to the device. These are stress ratings only, and functional operation of the device at these or any other conditions beyond those indicated under *recommended operating conditions* is not implied. Exposure to absolute maximum rated conditions for extended periods may affect device reliability.
- (2) All voltage values are with respect to network ground terminal.
- (3) Input pins may be driven in this voltage range regardless of presence or absence of V_M.
- (4) Power dissipation and thermal limits must be observed.

6.2 ESD Ratings

		VALUE	UNIT	
V _(ESD)	Electrostatic discharge	Human body model (HBM), per AEC Q100-002 ⁽¹⁾	±2000	
		Charged device model (CDM), per AEC Q100-011	Corner pins (1, 2, 23, 24, 48, and 27)	±750
			Other pins	±1000

- (1) AEC Q100-002 indicates HBM stressing is done in accordance with the ANSI/ESDA/JEDEC JS-001 specification.

6.3 Recommended Operating Conditions

over operating free-air temperature range (unless otherwise noted)

		MIN	NOM	MAX	UNIT
V _M	Motor power supply voltage	8		32	V
V _{REF}	VREF input voltage	1		4	V
I _{MOT}	Continuous motor drive output current ⁽¹⁾		1	1.5	A

- (1) Power dissipation and thermal limits must be observed.

6.4 Thermal Information

THERMAL METRIC ⁽¹⁾		DRV8823-Q1	UNIT
		DCA (HTSSOP)	
		48 PINS	
R _{θJA}	Junction-to-ambient thermal resistance	31.3	°C/W
R _{θJC(top)}	Junction-to-case (top) thermal resistance	16.3	°C/W
R _{θJB}	Junction-to-board thermal resistance	15	°C/W
ψ _{JT}	Junction-to-top characterization parameter	0.6	°C/W
ψ _{JB}	Junction-to-board characterization parameter	14.9	°C/W
R _{θJC(bot)}	Junction-to-case (bottom) thermal resistance	0.6	°C/W

- (1) For more information about traditional and new thermal metrics, see the *Semiconductor and IC Package Thermal Metrics* application report, [SPRA953](#).

6.5 Electrical Characteristics

over operating free-air temperature range (unless otherwise noted)

PARAMETER		TEST CONDITIONS	MIN	TYP	MAX	UNIT
POWER SUPPLIES						
I_{VM}	V_M operating supply current	$V_M = 24\text{ V}$, no loads		5	8	mA
V_{UVLO}	V_M undervoltage lockout voltage	V_M rising		6.5	8	V
V_{CP}	Charge pump voltage	Relative to V_M		12		V
V_{V3P3}	V_{V3P3} output voltage		3.20	3.30	3.40	V
LOGIC-LEVEL INPUTS (INTERNAL PULLDOWNS)						
V_{IL}	Input low voltage				0.7	V
V_{IH}	Input high voltage		2			V
V_{HYS}	Input hysteresis		0.3	0.45	0.6	V
I_{IN}	Input current (internal pulldown current)	$V_{IN} = 3.3\text{ V}$			100	μA
OVERTEMPERATURE PROTECTION						
T_{TSD}	Thermal shutdown temperature	Die temperature	150			$^{\circ}\text{C}$
MOTOR DRIVERS						
$R_{DS(ON)}$	Motor number 1 FET on resistance (each individual FET)	$V_M = 24\text{ V}$, $I_O = 0.8\text{ A}$, $T_A = 25^{\circ}\text{C}$		0.25		Ω
		$V_M = 24\text{ V}$, $I_O = 0.8\text{ A}$, $T_A = 85^{\circ}\text{C}$		0.31	0.37	
		$V_M = 24\text{ V}$, $I_O = 0.8\text{ A}$, $T_A = 85^{\circ}\text{C}$ to 125°C		.435	.570	
$R_{DS(ON)}$	Motor number 2 FET on resistance (each individual FET)	$V_M = 24\text{ V}$, $I_O = 0.8\text{ A}$, $T_A = 25^{\circ}\text{C}$		0.30		Ω
		$V_M = 24\text{ V}$, $I_O = 0.8\text{ A}$, $T_A = 85^{\circ}\text{C}$		0.38	0.45	
		$V_M = 24\text{ V}$, $I_O = 0.8\text{ A}$, $T_A = 85^{\circ}\text{C}$ to 125°C		.446	.570	
I_{OFF}	Off-state leakage current				± 12	μA
f_{PWM}	Motor PWM frequency ⁽¹⁾		42	50	57	kHz
t_{BLANK}	ITRIP blanking time ⁽²⁾			3.75		μs
t_F	Output fall time		50		350	ns
t_R	Output rise time		50		350	ns
I_{OCP}	Overcurrent protect level		1.5	3	4.5	A
t_{OCP}	Overcurrent protect trip time		2.7			μs
t_{MD}	Mixed decay percentage	Measured from beginning of PWM cycle		75%		
CURRENT CONTROL						
I_{REF}	xVREF input current	xVREF = 3.3 V	-3%		3	μA
ΔI_{CHOP}	Chopping current accuracy	xVREF = 2.5 V, derived from V3P3; 71% to 100% current	-5%		5%	
		xVREF = 2.5 V, derived from V3P3; 20% to 56% current	-10%		10%	

(1) Factory option 100 kHz.

 (2) Factory options for 2.5 μs , 5 μs or 6.25 μs .

6.6 Timing Requirements

over operating free-air temperature range (unless otherwise noted)

			MIN	MAX	UNIT
1	t_{CYC}	Clock cycle time	62		ns
2	t_{CLKH}	Clock high time	25		ns
3	t_{CLKL}	Clock low time	25		ns
4	$t_{SU(SDATA)}$	Setup time, SDATA to SCLK	5		ns
5	$t_{H(DATA)}$	Hold time, SDATA to SCLK	1		ns
6	$t_{SU(SCS)}$	Setup time, SCS to SCLK	5		ns
7	$t_{H(SCS)}$	Hold time, SCS to SCLK	1		ns

6.7 Dissipation Ratings

BOARD	PACKAGE	R _{θJA}	DERATING FACTOR ABOVE T _A = 25°C	T _A < 25°C	T _A = 70°C	T _A = 85°C	T _A = 125°C
Low-K ⁽¹⁾	DCA	75.7°C/W	13.2 mW/°C	1.65 W	1.06 W	0.86 W	0.332 W
Low-K ⁽²⁾		32°C/W	31.3 mW/°C	3.91 W	2.50 W	2.03 W	0.778 W
High-K ⁽³⁾		30.3°C/W	33 mW/°C	4.13 W	2.48 W	2.15 W	0.83 W
High-K ⁽⁴⁾		22.3°C/W	44.8 mW/°C	5.61 W	3.59 W	2.91 W	1.118 W

- (1) The JEDEC Low-K board used to derive this data was a 76-mm x 114-mm, 2-layer, 1.6-mm thick PCB with no backside copper.
- (2) The JEDEC Low-K board used to derive this data was a 76-mm x 114-mm, 2-layer, 1.6-mm thick PCB with 25-cm² 2-oz copper on back side.
- (3) The JEDEC High-K board used to derive this data was a 76-mm x 114-mm, 4-layer, 1.6-mm thick PCB with no backside copper and solid 1-oz internal ground plane.
- (4) The JEDEC High-K board used to derive this data was a 76-mm x 114-mm, 4-layer, 1.6-mm thick PCB with 25-cm² 1-oz copper on back side and solid 1-oz internal ground plane.

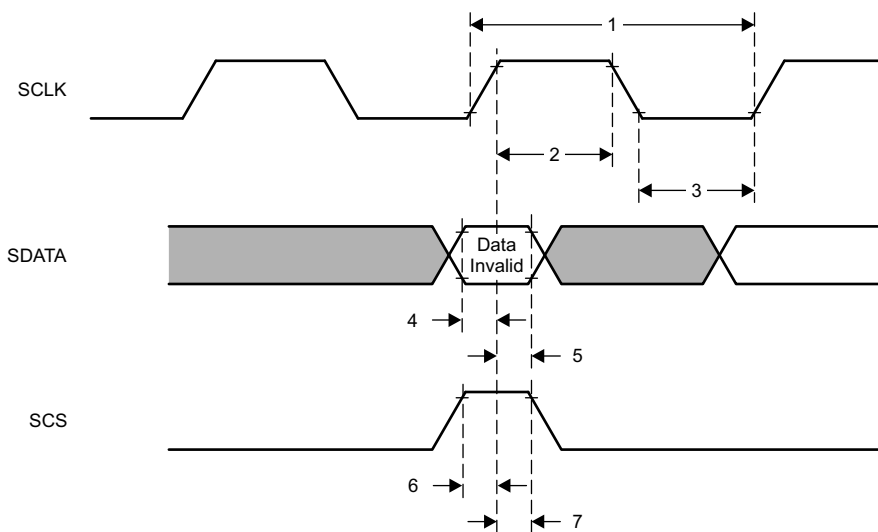

Figure 2. Timing Diagram

6.8 Typical Characteristics

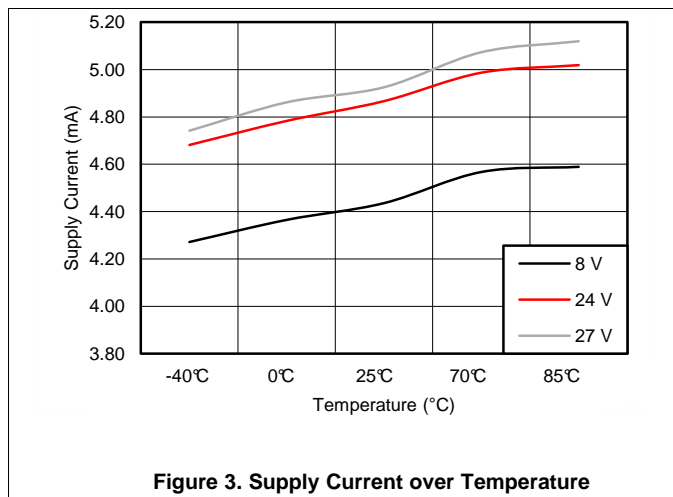

Figure 3. Supply Current over Temperature

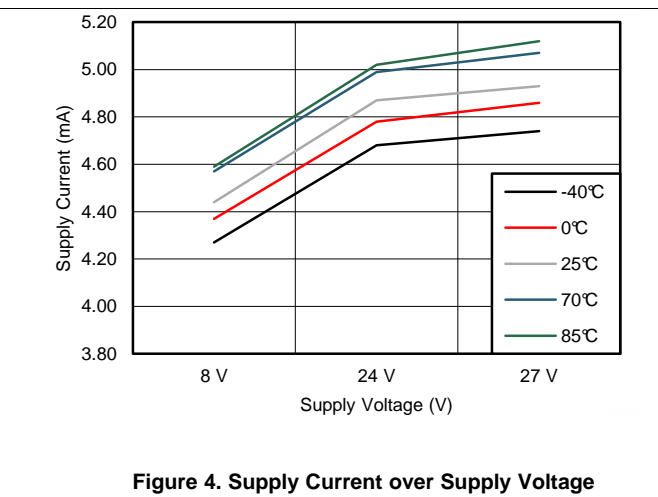
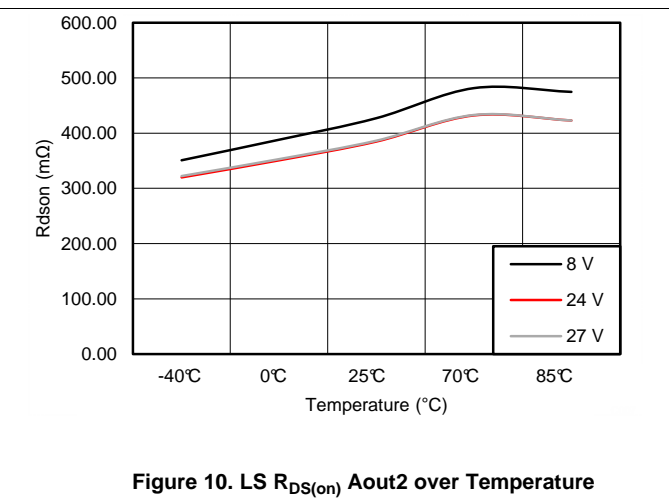
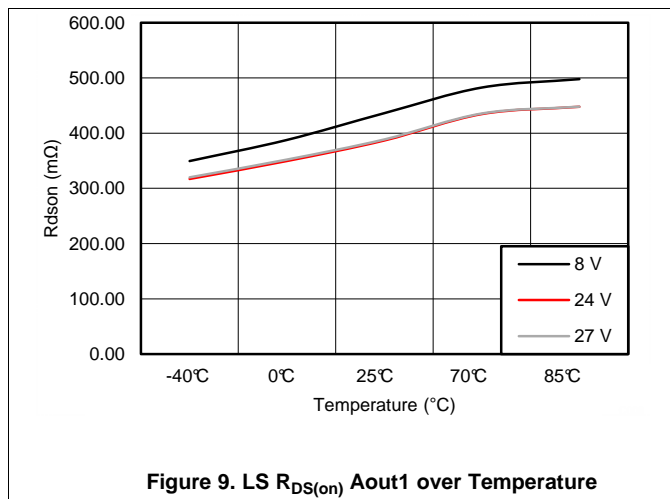
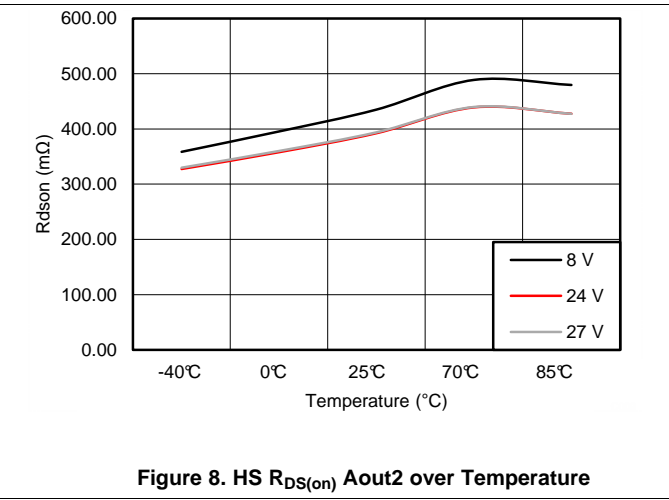
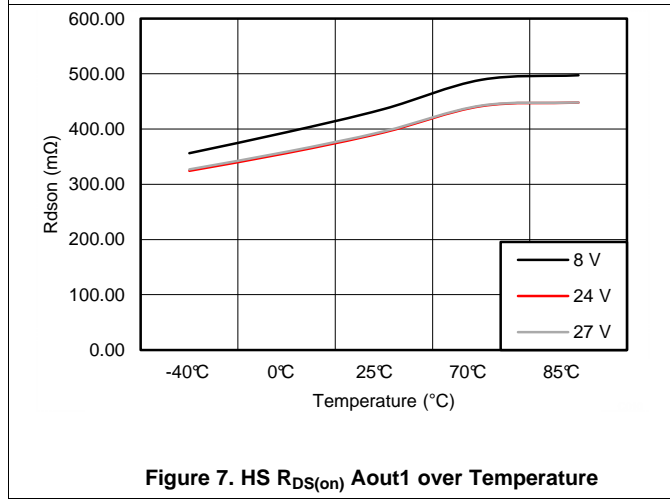
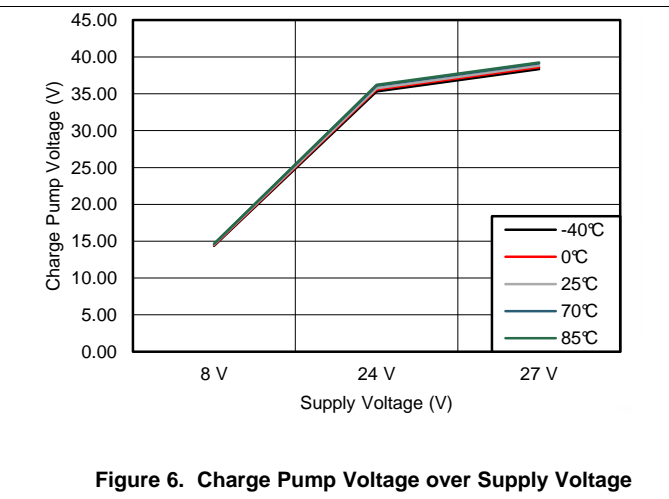
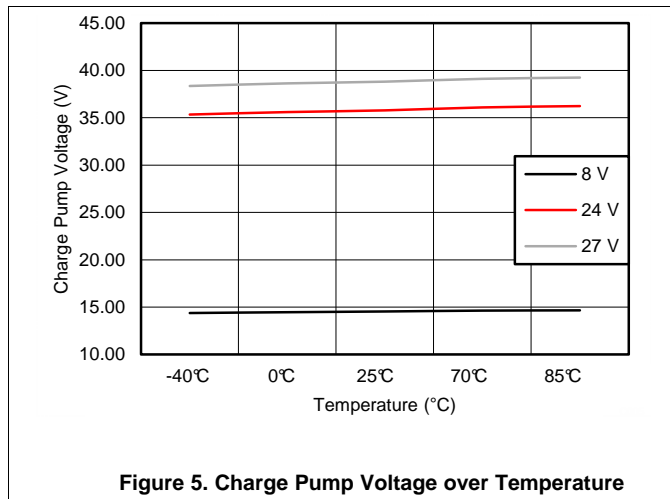

Figure 4. Supply Current over Supply Voltage

Typical Characteristics (continued)



7 Detailed Description

7.1 Overview

The DRV8823-Q1 is a dual stepper motor driver solution for automotive applications that require independent control of two different motors. The device integrates four NMOS H-bridges, a microstepping indexer, and various fault protection features. The DRV8823-Q1 can be powered with a supply voltage between 8 V and 32 V, and is capable of providing an output current up to 1.5-A full scale. Actual full-scale current will depend on ambient temperature, supply voltage and PCB ground size.

A serial data interface is included to control all functions of the motor driver. Current regulation through all four H-bridges is achieved using three register bits per H-bridge. The three register bits are used to scale the current in each bridge as a percentage of the full-scale current set by VREF input pin and sense resistor. The current regulation is configurable with two different decay modes; slow decay and mixed decay.

The gate drive to each FET in all four H-Bridges is controlled to prevent any cross-conduction (shoot-through current) during transitions.

7.2 Functional Block Diagram

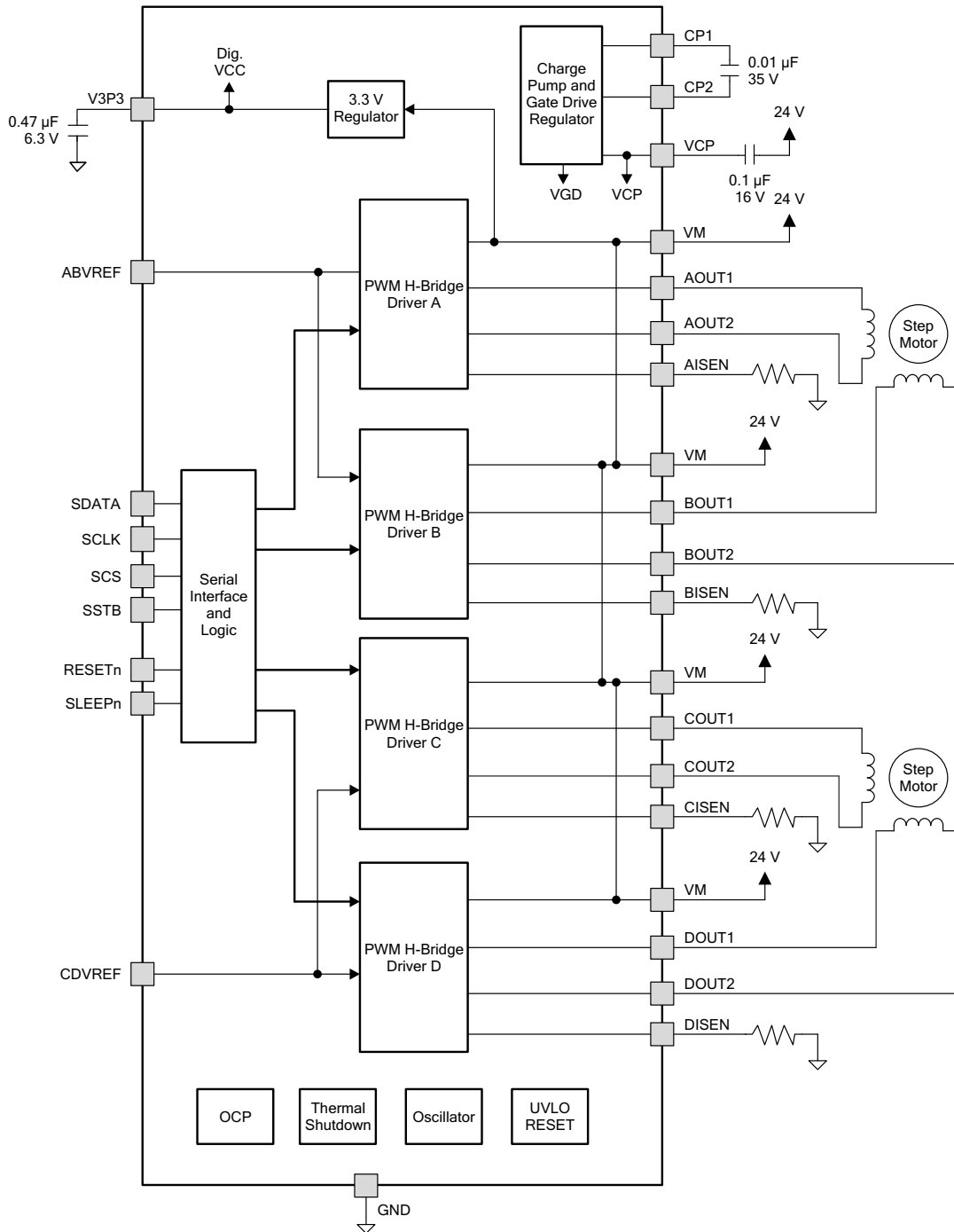

7.3 Feature Description

7.3.1 PWM Motor Drivers

The DRV8823-Q1 device contains four H-bridge motor drivers with current-control PWM circuitry. A block diagram showing drivers A and B of the motor control circuitry (as typically used to drive a bipolar stepper motor) is shown in Figure 11. Drivers C and D are the same as A and B (though the $R_{DS(ON)}$ of the output FETs is different).

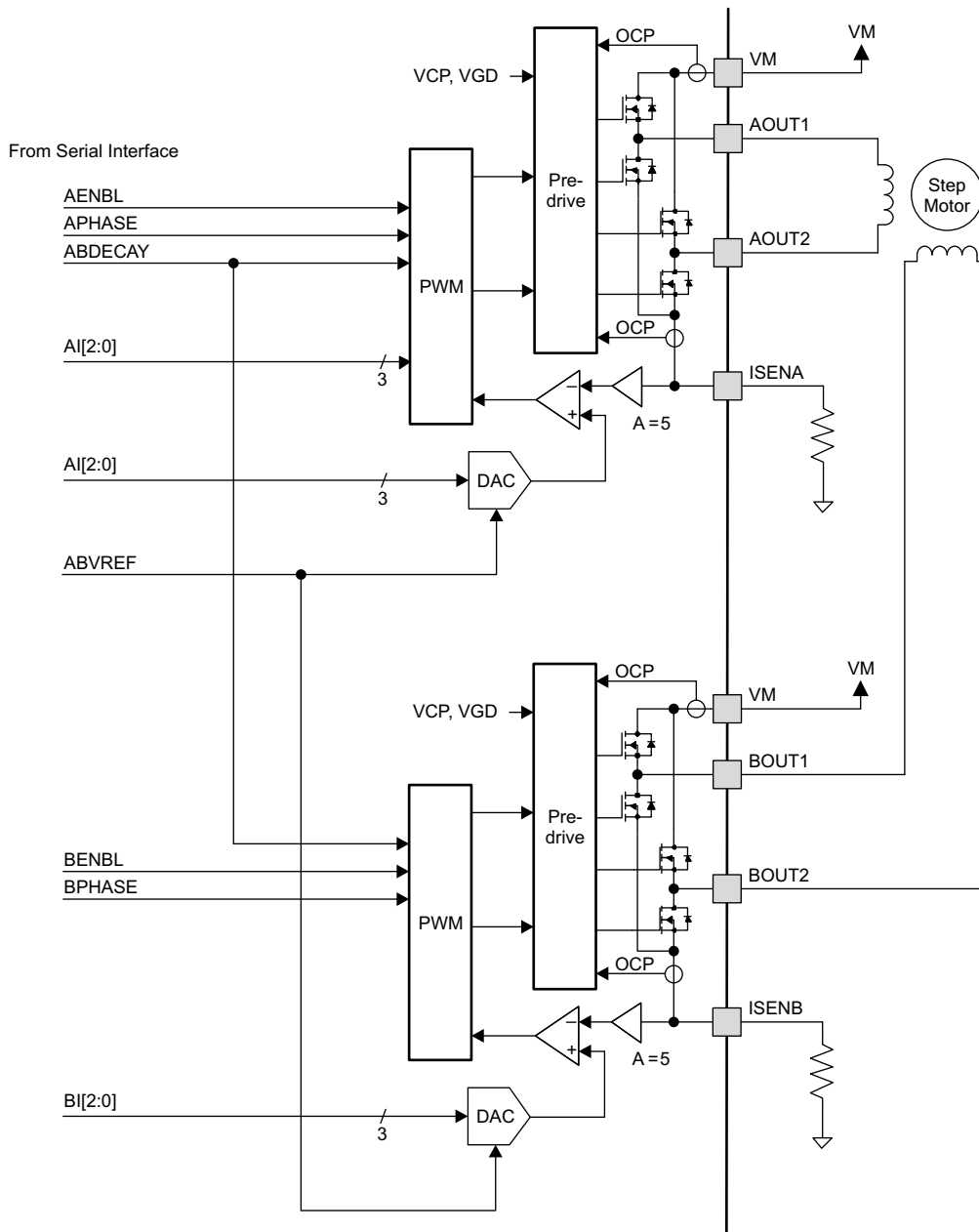

Figure 11. Motor Driver Circuit

Note that there are multiple VM motor power supply pins. All VM pins must be connected together to the motor supply voltage.

Feature Description (continued)

7.3.2 Protection Circuits

The DRV8823-Q1 device is fully protected against undervoltage, overcurrent, and overtemperature events.

7.3.2.1 Overcurrent Protection (OCP)

All of the drivers in the DRV8823-Q1 device are protected with an overcurrent protection (OCP) circuit.

The OCP circuit includes an analog current limit circuit, which acts by removing the gate drive from each output FET if the current through it exceeds a preset level. This circuit limits the current to a level that is safe to prevent damage to the FET.

A digital circuit monitors the analog current limit circuits. If any analog current limit condition exists for longer than a preset period, all drivers in the device are disabled.

The device is re-enabled upon the removal and re-application of power at the VM pins.

7.3.2.2 Thermal Shutdown (TSD)

If the die temperature exceeds safe limits, all drivers in the device are shut down.

The device remains disabled until the die temperature falls to a safe level. After the temperature falls, the device may be re-enabled upon the removal and re-application of power at the VM pin.

7.3.2.3 Undervoltage Lockout (UVLO)

If at any time the voltage on the VM pins falls below the undervoltage lockout threshold voltage, all circuitry in the device is disabled. Operation resumes when VM rises above the UVLO threshold. The indexer logic is reset to its initial condition in the event of a UVLO.

7.3.2.4 Shoot-Through Current Prevention

The gate drive to each FET in the H-bridge is controlled to prevent any cross-conduction (shoot-through current) during transitions.

7.4 Device Functional Modes

7.4.1 Bridge Control

The xENBL bits in the serial interface registers enable current flow in each H-bridge when set to 1.

The xPHASE bits in the serial interface registers control the direction of current flow through each H-bridge. [Table 1](#) shows the logic.

Table 1. H-Bridge Logic

xPHASE	xOUT1	xOUT2
1	H	L
0	L	H

7.4.2 Current Regulation

The motor driver employs fixed-frequency PWM current regulation (also called current chopping). When a winding is activated, the current through it rises until it reaches a threshold, then the current is switched off until the next PWM period.

The PWM frequency is fixed at 50 kHz, but it may also be set to 100 kHz through the factory option.

The PWM chopping current is set by a comparator which compares the voltage across a current sense resistor connected to the xISEN pins, multiplied by a factor of 5, with a reference voltage. The reference voltage is input from the VREF pin.

The full-scale (100%) chopping current is calculated as follows:

$$I_{\text{CHOP}} = \frac{V_{\text{REFX}}}{5 \times R_{\text{ISENSE}}} \quad (1)$$

Example:

If a 0.5-Ω sense resistor is used and the V_{REFX} pin is 2.5 V, the full-scale (100%) chopping current is: 2.5 V/(5 × 0.5 Ω) = 1 A.

Three serial interface register bits per H-bridge (x12, x11 and x10) are used to scale the current in each bridge as a percentage of the full-scale current set by the VREF input pin and sense resistance. The function of the bits is shown in [Table 2](#).

Table 2. H-Bridge Bit Functions

x12	x11	x10	RELATIVE CURRENT (% FULL-SCALE CHOPPING CURRENT)
0	0	0	20
0	0	1	38
0	1	0	56
0	1	1	71
1	0	0	83
1	0	1	92
1	1	0	98
1	1	1	100

7.4.3 Decay Mode

During PWM current chopping, the H-bridge is enabled to drive through the motor winding until the PWM current chopping threshold is reached. This is shown in [Figure 12](#) as case 1. The current flow direction shown indicates positive current flow in [Figure 12](#).

Once the chopping current threshold is reached, the H-bridge can operate in two different states, fast decay or slow decay.

In fast decay mode, once the PWM chopping current level has been reached, the H-bridge reverses state to allow winding current to flow in a reverse direction. As the winding current approaches zero, the bridge is disabled to prevent any reverse current flow. Fast decay mode is shown in [Figure 12](#) as case 2.

In slow decay mode, winding current is recirculated by enabling both of the low-side FETs in the bridge. This is shown in [Figure 12](#) as case 3.

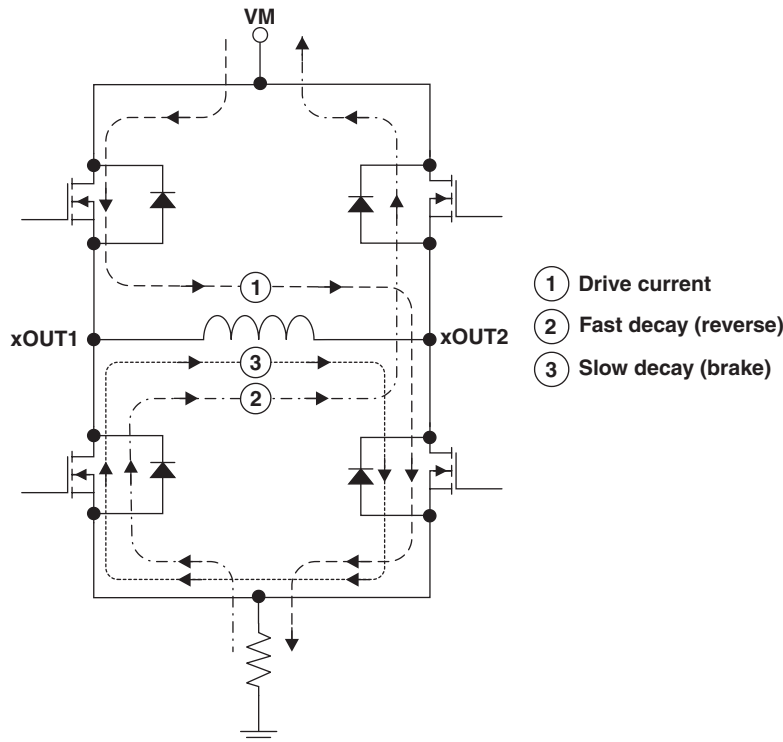

Figure 12. Decay Mode

The DRV8823-Q1 device supports slow decay and a mixed decay mode. Mixed decay mode begins as fast decay, but at a fixed period of time (75% of the PWM cycle) switches to slow decay mode for the remainder of the fixed PWM period.

Slow or mixed decay mode is selected by the state of the xDECAY bits in the serial interface registers. If the xDECAY bit is 0, slow decay is selected. If the xDECAY bit is 1, mixed decay is selected.

7.4.4 Blanking Time

After the current is enabled in an H-bridge, the voltage on the xISEN pin is ignored for a fixed period of time before enabling the current sense circuitry. This blanking time is fixed at 3.75 μ s. Note that the blanking time also sets the minimum on time of the PWM.

7.5 Programming

7.5.1 Serial Data Transmission

Data transfers consist of 16 bits of serial data, shifted into the SDATA pin LSB first.

On serial writes to the DRV8823-Q1 device, additional clock edges following the final data bit continues to shift data bits into the data register; therefore, the last 16 bits presented are latched and used.

One of two registers is selected by setting bits in an address field in the four upper bits in the serial data transferred (ADDR in the tables below). One 16-bit register is used to control motor number 1 (bridges A and B), and a second 16-bit register is used to control motor 2 (bridges C and D).

Data can only be transferred into the serial interface if the SCS input pin is active high.

Data is initially clocked in to a temporary holding register. This data is latched into the motor driver on the rising edge of the SSTB pin. If the SSTB pin is tied high at all times, the data will be latched in after all 16 bits have been transferred.

Programming (continued)

Table 3. Motor 1 Command (Bridges A and B)

Bit	D15–D12	D11	D10	D9	D8	D7	D6	D5	D4	D3	D2	D1	D0
Name	ADDR (= 0000)	BDECAY	B12	B11	B10	BPHASE	BENBL	ADECAY	A12	A11	A10	APHASE	AENBL
Reset Value	x	0	0	0	0	0	0	0	0	0	0	0	0

Table 4. Motor 2 Command (Bridges C and D)

Bit	D15–D12	D11	D10	D9	D8	D7	D6	D5	D4	D3	D2	D1	D0
Name	ADDR (= 0001)	DDECAY	D12	D11	D10	DPHASE	DENBL	CDECAY	C12	C11	C10	CPHASE	CENBL
Reset Value	x	0	0	0	0	0	0	0	0	0	0	0	0

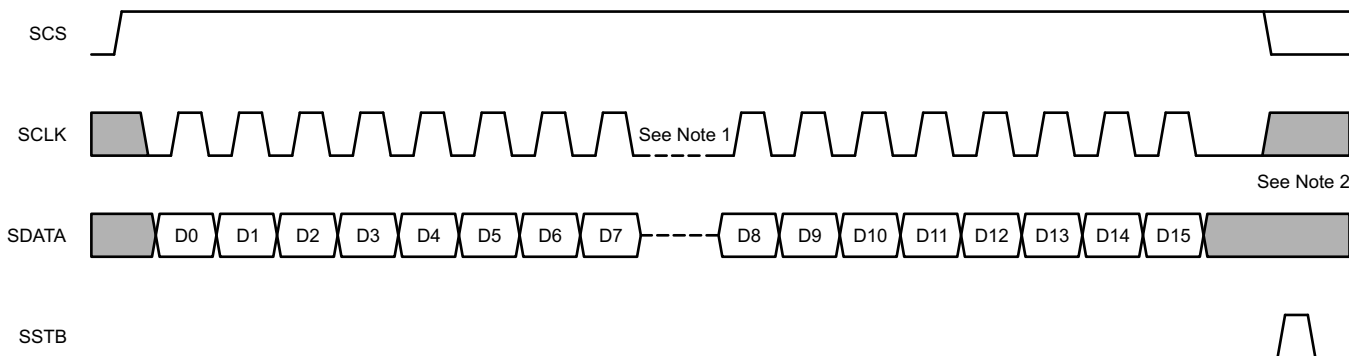

Note 1: Any amount of time is allowed between clocks, or groups of clocks, as long as SCS stays active. This allows 8- or 16-bit transfers.

Note 2: If more than 16 clock edges are presented while transferring data (while SCS is still high), data continues to be shifted into the data register.

Figure 13. Serial Data Timing Diagram

Typical Application (continued)

8.2.1 Design Requirements

Table 5 lists the design requirements for this design example.

Table 5. Design Parameters

DESIGN PARAMETER	REFERENCE	EXAMPLE VALUE
Supply voltage	V_M	24 V
Motor winding resistance	R_L	7.4 Ω /phase
Motor full-step angle	θ_{step}	1.8°/step
Target microstepping angle	η_M	1/8 step
Target motor speed	V	120 rpm
Target full-scale current	I_{FS}	1 A

8.2.2 Detailed Design Procedure

8.2.2.1 Motor Voltage

The appropriate motor voltage will depend on the ratings of the motor selected and the desired torque. A higher voltage shortens the current rise time in the coils of the stepper motor allowing a greater average torque. Using a higher voltage also allows the motor to operate at a faster speed than a lower voltage.

8.2.2.2 Drive Current

The current path running to the motor starts from the supply V_M , then goes through the high-side sourcing NMOS power FET, moves through the inductive winding load of the motor, then through the low-side sinking NMOS power FET, and finally going through the external sense resistor. Power dissipation losses in both NMOS power FETs inside of the DRV8823-Q1 are shown in the following equation.

$$P = I^2 \times (R_{DS(on)} \times 2) \tag{2}$$

The DRV8823-Q1 has been measured to be capable of 1.5-A continuous current with the HTSSOP package at 25°C on standard FR-4 PCBs. The max continuous current will vary based on PCB design and the ambient temperature.

8.2.3 Application Curves

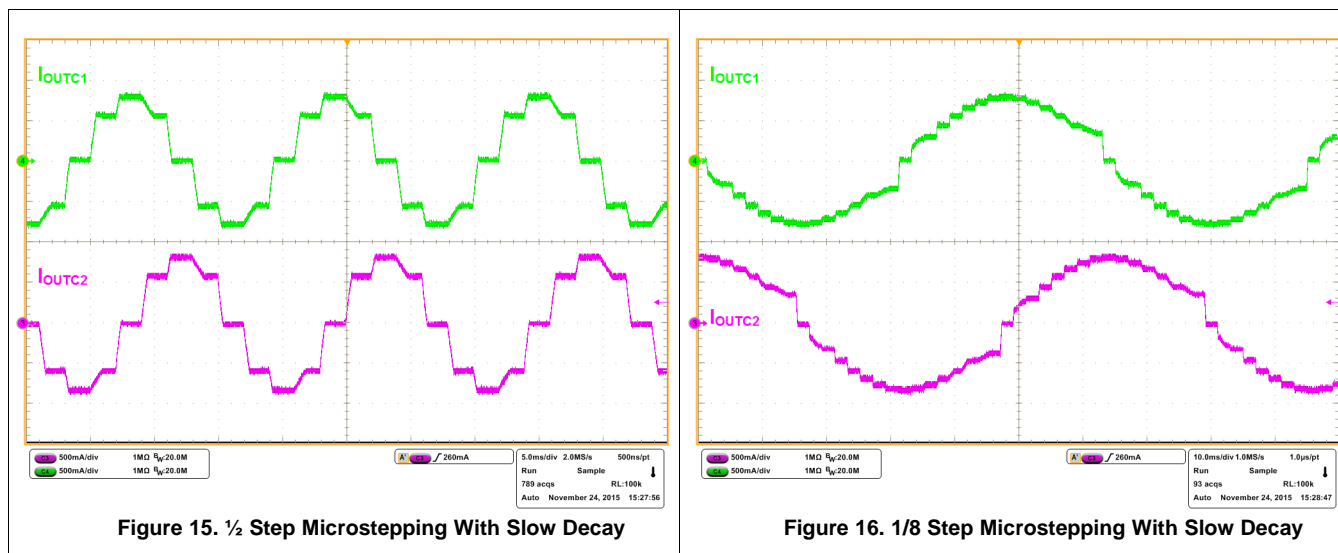

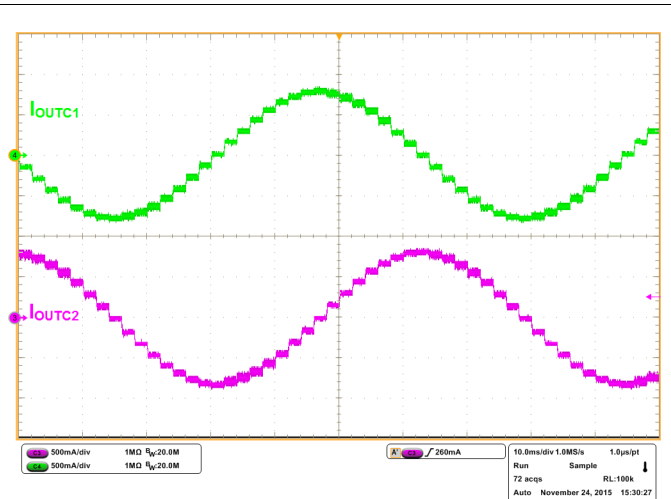
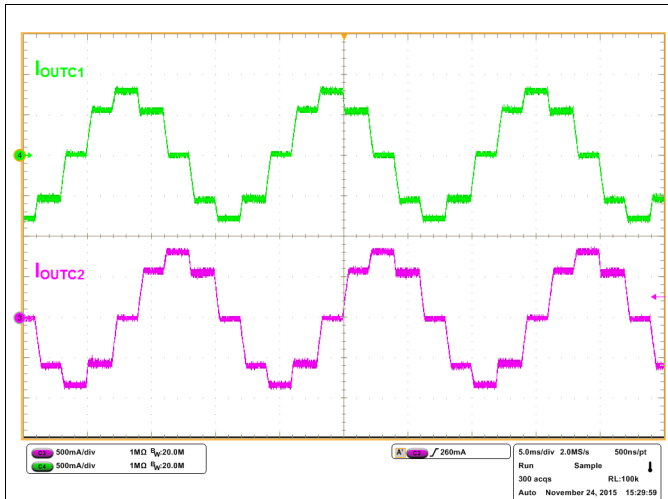

9 Power Supply Recommendations

Having appropriate local bulk capacitance is an important factor in motor drive system design. It is generally beneficial to have more bulk capacitance, while the disadvantages are increased cost and physical size. The amount of local capacitance needed depends on a variety of factors, including

- Highest current required by the motor system
- Power supply's capacitance and ability to source current
- Amount of parasitic inductance between the power supply and motor system
- Acceptable voltage ripple
- Type of motor used (brushed DC, brushless DC, stepper)
- Motor braking method

The inductance between the power supply and motor drive system will limit the rate current can change from the power supply. If the local bulk capacitance is too small, the system will respond to excessive current demands or dumps from the motor with a change in voltage. When adequate bulk capacitance is used, the motor voltage remains stable and high current can be quickly supplied.

The data sheet generally provides a recommended value, but system-level testing is required to determine the appropriate sized bulk capacitor.

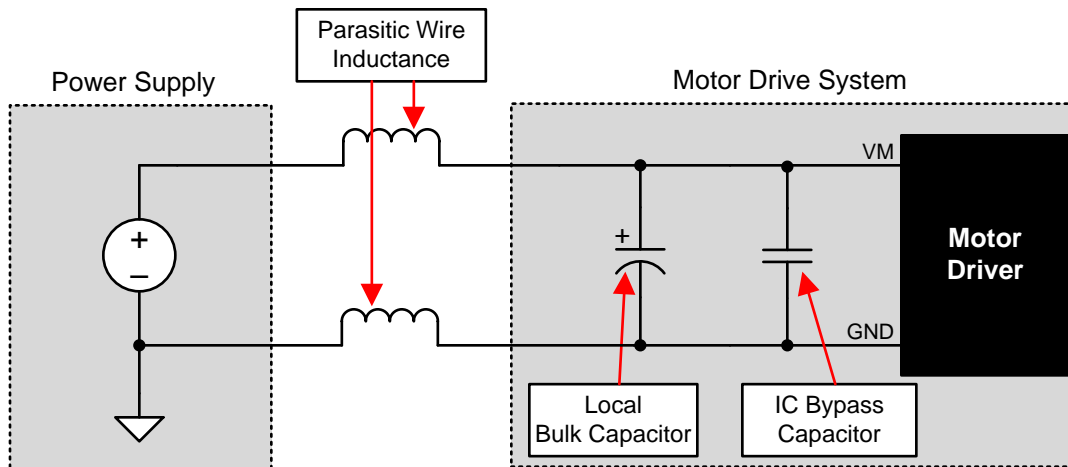

Figure 19. Example Setup of Motor Drive System With External Power Supply

The voltage rating for bulk capacitors should be higher than the operating voltage, to provide margin for cases when the motor transfers energy to the supply.

10 Layout

10.1 Layout Guidelines

The bulk capacitor should be placed to minimize the distance of the high-current path through the motor driver device. The connecting metal trace widths should be as wide as possible, and numerous vias should be used when connecting PCB layers. These practices minimize inductance and allow the bulk capacitor to deliver high current.

Small-value capacitors should be ceramic, and placed closely to device pins.

The high-current device outputs should use wide metal traces.

The device thermal pad should be soldered to the PCB top-layer ground plane. Multiple vias should be used to connect to a large bottom-layer ground plane. The use of large metal planes and multiple vias help dissipate the $I^2 \times RDS(on)$ heat that is generated in the device.

10.2 Layout Example

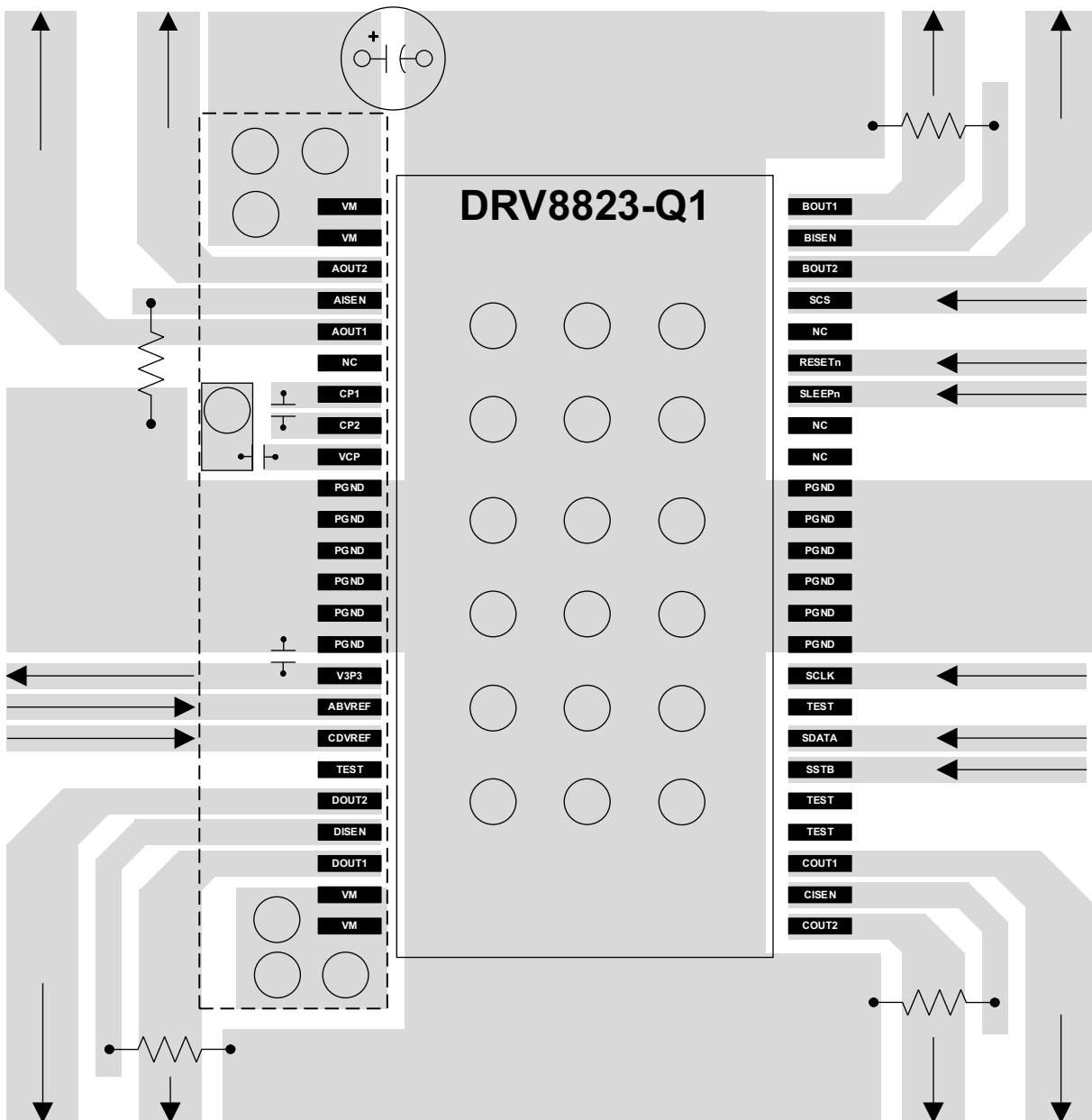

Figure 20. Typical Layout of DRV8823-Q1

10.3 Thermal Considerations

The DRV8823-Q1 device has thermal shutdown (TSD) as described above. If the die temperature exceeds approximately 150°C, the device is disabled until the temperature drops to a safe level.

Any tendency of the device to enter thermal shutdown is an indication of either excessive power dissipation, insufficient heatsinking, or too high an ambient temperature.

10.3.1 Power Dissipation

Power dissipation in the DRV8823-Q1 device is dominated by the power dissipated in the output FET resistance, or $R_{DS(ON)}$. Average power dissipation when running a stepper motor can be roughly estimated by [Equation 3](#).

Thermal Considerations (continued)

$$P_{TOT} = 4 \times R_{DS(ON)} \times (I_{OUT(RMS)})^2 \quad (3)$$

Where: P_{TOT} is the total power dissipation, $R_{DS(ON)}$ is the resistance of each FET, and $I_{OUT(RMS)}$ is the RMS output current applied to each winding. $I_{OUT(RMS)}$ is equal to approximately 0.7x the full-scale output current setting. The factor of 4 is derived from the two motor windings, and at any instant two FETs are conducting winding current for each winding (one high-side and one low-side). The DRV8823-Q1 device has two stepper motor drivers, so the power dissipation of each must be added together to determine the total device power dissipation.

The maximum amount of power that can be dissipated in the DRV8823-Q1 device is dependent on ambient temperature and heatsinking. The thermal dissipation ratings table in the datasheet can be used to estimate the temperature rise for typical PCB constructions.

Note that $R_{DS(ON)}$ increases with temperature, so as the device heats, the power dissipation increases. This must be taken into consideration when sizing the heatsink.

10.3.2 Heatsinking

The PowerPAD integrated circuit package uses an exposed pad to remove heat from the device. For proper operation, this pad must be thermally connected to copper on the PCB to dissipate heat. On a multi-layer PCB with a ground plane, this can be accomplished by adding a number of vias to connect the thermal pad to the ground plane. On PCBs without internal planes, copper area can be added on either side of the PCB to dissipate heat. If the copper area is on the opposite side of the PCB from the device, thermal vias are used to transfer the heat between top and bottom layers.

For details about how to design the PCB, refer to TI application report [SLMA002, PowerPAD™ Thermally Enhanced Package](#) and TI application brief [SLMA004, PowerPAD™ Made Easy](#), available at www.ti.com.

In general, the more copper area that can be provided, the more power can be dissipated. [Figure 21](#) shows thermal resistance versus copper plane area for both a single-sided PCB with 2-oz copper heatsink area, and a 4-layer PCB with 1-oz copper and a solid ground plane. Both PCBs are 76 mm x 114 mm, and 1.6 mm thick. The heatsink effectiveness increases rapidly to about 20 cm², then levels off somewhat for larger areas.

Six pins on the center of each side of the package are also connected to the device ground. A copper area can be used on the PCB that connects to the PowerPAD integrated circuit package as well as to all the ground pins on each side of the device, which is especially useful for single-layer PCB designs.

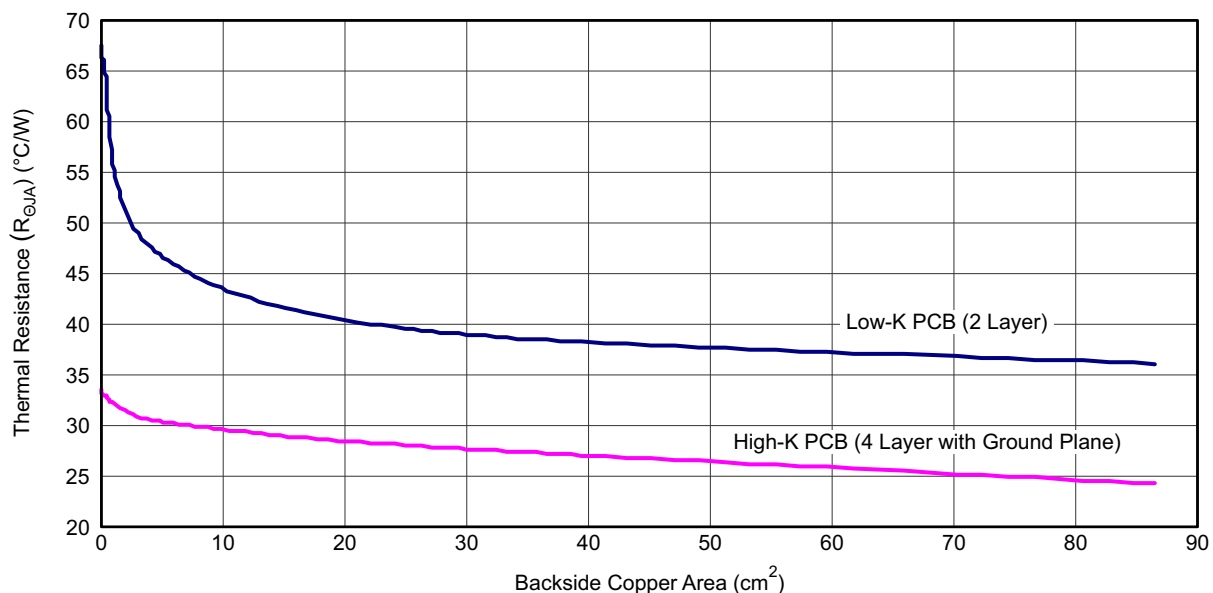

Figure 21. Thermal Resistance vs Copper Plane Area

11 Device and Documentation Support

11.1 Documentation Support

11.1.1 Related Documentation

For related documentation see the following:

- *PowerPAD™ Thermally Enhanced Package* [SLMA002](#)
- *PowerPAD™ Made Easy* [SLMA004](#)
- *Current Recirculation and Decay Modes*, [SLVA321](#)
- *Calculating Motor Driver Power Dissipation*, [SLVA504](#)
- *Understanding Motor Driver Current Ratings*, [SLVA505](#)

11.2 Community Resources

The following links connect to TI community resources. Linked contents are provided "AS IS" by the respective contributors. They do not constitute TI specifications and do not necessarily reflect TI's views; see TI's [Terms of Use](#).

TI E2E™ Online Community *TI's Engineer-to-Engineer (E2E) Community*. Created to foster collaboration among engineers. At e2e.ti.com, you can ask questions, share knowledge, explore ideas and help solve problems with fellow engineers.

Design Support *TI's Design Support* Quickly find helpful E2E forums along with design support tools and contact information for technical support.

11.3 Trademarks

E2E is a trademark of Texas Instruments.

All other trademarks are the property of their respective owners.

11.4 Electrostatic Discharge Caution



These devices have limited built-in ESD protection. The leads should be shorted together or the device placed in conductive foam during storage or handling to prevent electrostatic damage to the MOS gates.

11.5 Glossary

[SLYZ022](#) — *TI Glossary*.

This glossary lists and explains terms, acronyms, and definitions.

12 Mechanical, Packaging, and Orderable Information

The following pages include mechanical, packaging, and orderable information. This information is the most current data available for the designated devices. This data is subject to change without notice and revision of this document. For browser-based versions of this data sheet, refer to the left-hand navigation.

PACKAGING INFORMATION

Orderable Device	Status (1)	Package Type	Package Drawing	Pins	Package Qty	Eco Plan (2)	Lead/Ball Finish (6)	MSL Peak Temp (3)	Op Temp (°C)	Device Marking (4/5)	Samples
DRV8823QDCARQ1	ACTIVE	HTSSOP	DCA	48	2000	Green (RoHS & no Sb/Br)	CU NIPDAU	Level-3-260C-168 HR	-40 to 125	DRV8823Q	Samples

(1) The marketing status values are defined as follows:

ACTIVE: Product device recommended for new designs.

LIFEBUY: TI has announced that the device will be discontinued, and a lifetime-buy period is in effect.

NRND: Not recommended for new designs. Device is in production to support existing customers, but TI does not recommend using this part in a new design.

PREVIEW: Device has been announced but is not in production. Samples may or may not be available.

OBSELETE: TI has discontinued the production of the device.

(2) Eco Plan - The planned eco-friendly classification: Pb-Free (RoHS), Pb-Free (RoHS Exempt), or Green (RoHS & no Sb/Br) - please check <http://www.ti.com/productcontent> for the latest availability information and additional product content details.

TBD: The Pb-Free/Green conversion plan has not been defined.

Pb-Free (RoHS): TI's terms "Lead-Free" or "Pb-Free" mean semiconductor products that are compatible with the current RoHS requirements for all 6 substances, including the requirement that lead not exceed 0.1% by weight in homogeneous materials. Where designed to be soldered at high temperatures, TI Pb-Free products are suitable for use in specified lead-free processes.

Pb-Free (RoHS Exempt): This component has a RoHS exemption for either 1) lead-based flip-chip solder bumps used between the die and package, or 2) lead-based die adhesive used between the die and leadframe. The component is otherwise considered Pb-Free (RoHS compatible) as defined above.

Green (RoHS & no Sb/Br): TI defines "Green" to mean Pb-Free (RoHS compatible), and free of Bromine (Br) and Antimony (Sb) based flame retardants (Br or Sb do not exceed 0.1% by weight in homogeneous material)

(3) MSL, Peak Temp. - The Moisture Sensitivity Level rating according to the JEDEC industry standard classifications, and peak solder temperature.

(4) There may be additional marking, which relates to the logo, the lot trace code information, or the environmental category on the device.

(5) Multiple Device Markings will be inside parentheses. Only one Device Marking contained in parentheses and separated by a "~" will appear on a device. If a line is indented then it is a continuation of the previous line and the two combined represent the entire Device Marking for that device.

(6) Lead/Ball Finish - Orderable Devices may have multiple material finish options. Finish options are separated by a vertical ruled line. Lead/Ball Finish values may wrap to two lines if the finish value exceeds the maximum column width.

Important Information and Disclaimer:The information provided on this page represents TI's knowledge and belief as of the date that it is provided. TI bases its knowledge and belief on information provided by third parties, and makes no representation or warranty as to the accuracy of such information. Efforts are underway to better integrate information from third parties. TI has taken and continues to take reasonable steps to provide representative and accurate information but may not have conducted destructive testing or chemical analysis on incoming materials and chemicals. TI and TI suppliers consider certain information to be proprietary, and thus CAS numbers and other limited information may not be available for release.

In no event shall TI's liability arising out of such information exceed the total purchase price of the TI part(s) at issue in this document sold by TI to Customer on an annual basis.

OTHER QUALIFIED VERSIONS OF DRV8823-Q1 :

- Catalog: [DRV8823](#)

NOTE: Qualified Version Definitions:

- Catalog - TI's standard catalog product

TAPE AND REEL INFORMATION



QUADRANT ASSIGNMENTS FOR PIN 1 ORIENTATION IN TAPE



*All dimensions are nominal

Device	Package Type	Package Drawing	Pins	SPQ	Reel Diameter (mm)	Reel Width W1 (mm)	A0 (mm)	B0 (mm)	K0 (mm)	P1 (mm)	W (mm)	Pin1 Quadrant
DRV8823QDCARQ1	HTSSOP	DCA	48	2000	330.0	24.4	8.6	13.0	1.8	12.0	24.0	Q1

TAPE AND REEL BOX DIMENSIONS



*All dimensions are nominal

Device	Package Type	Package Drawing	Pins	SPQ	Length (mm)	Width (mm)	Height (mm)
DRV8823QDCARQ1	HTSSOP	DCA	48	2000	350.0	350.0	43.0

MECHANICAL DATA

DCA (R-PDSO-G48)

PowerPAD™ PLASTIC SMALL-OUTLINE

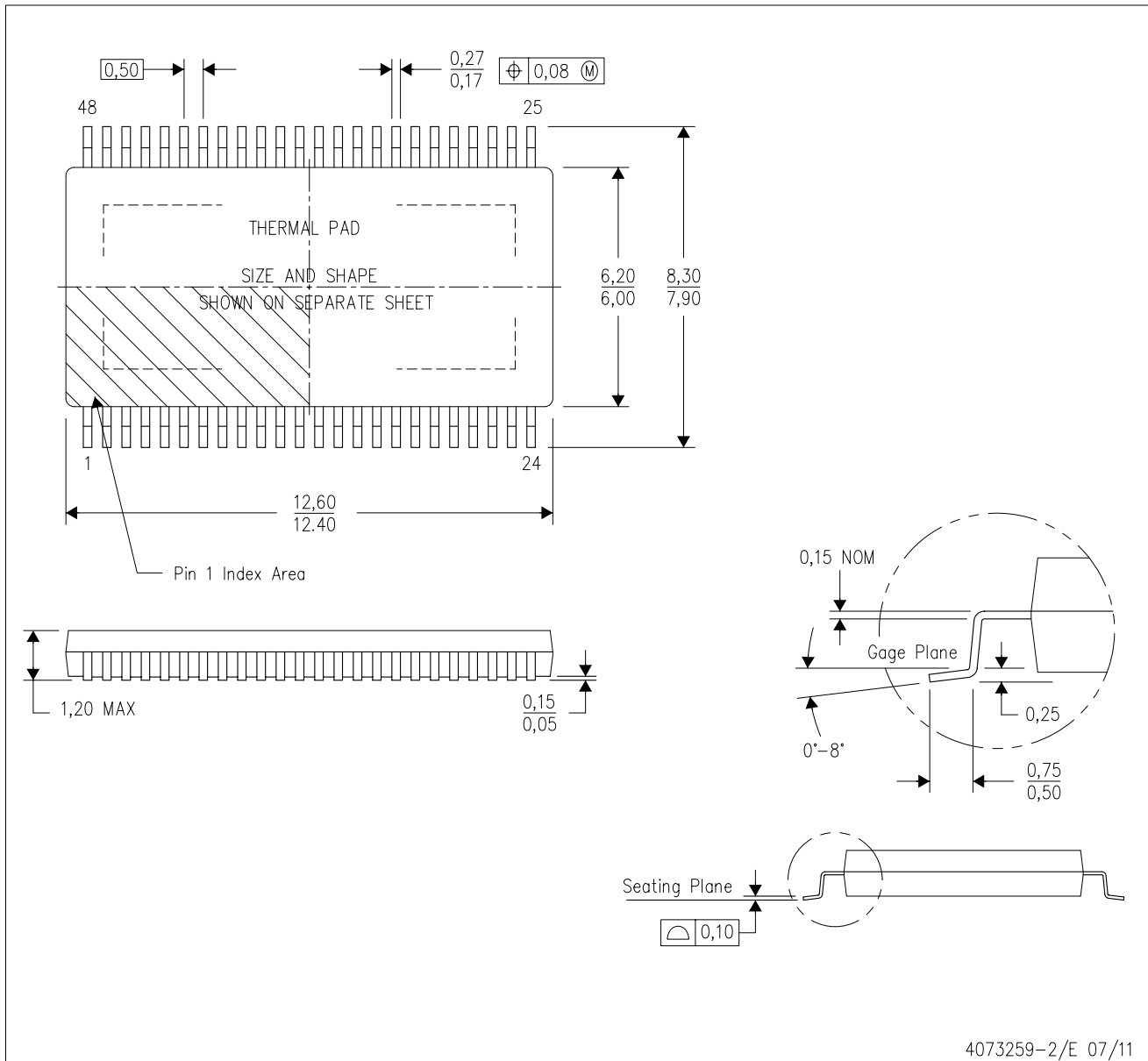

- NOTES:
- A. All linear dimensions are in millimeters. Dimensioning and tolerancing per ASME Y14.5M-1994.
 - B. This drawing is subject to change without notice.
 - C. Body dimensions do not include mold flash or protrusion not to exceed 0,15.
 - D. This package is designed to be soldered to a thermal pad on the board. Refer to Technical Brief, PowerPad Thermally Enhanced Package, Texas Instruments Literature No. SLMA002 for information regarding recommended board layout. This document is available at www.ti.com <<http://www.ti.com>>.
 - E. See the additional figure in the Product Data Sheet for details regarding the exposed thermal pad features and dimensions.
 - F. Falls within JEDEC MO-153

PowerPAD is a trademark of Texas Instruments.

THERMAL PAD MECHANICAL DATA

DCA (R-PDSO-G48)

PowerPAD™ PLASTIC SMALL OUTLINE

THERMAL INFORMATION

This PowerPAD™ package incorporates an exposed thermal pad that is designed to be attached to a printed circuit board (PCB). The thermal pad must be soldered directly to the PCB. After soldering, the PCB can be used as a heatsink. In addition, through the use of thermal vias, the thermal pad can be attached directly to the appropriate copper plane shown in the electrical schematic for the device, or alternatively, can be attached to a special heatsink structure designed into the PCB. This design optimizes the heat transfer from the integrated circuit (IC).

For additional information on the PowerPAD package and how to take advantage of its heat dissipating abilities, refer to Technical Brief, PowerPAD Thermally Enhanced Package, Texas Instruments Literature No. SLMA002 and Application Brief, PowerPAD Made Easy, Texas Instruments Literature No. SLMA004. Both documents are available at www.ti.com.

The exposed thermal pad dimensions for this package are shown in the following illustration.

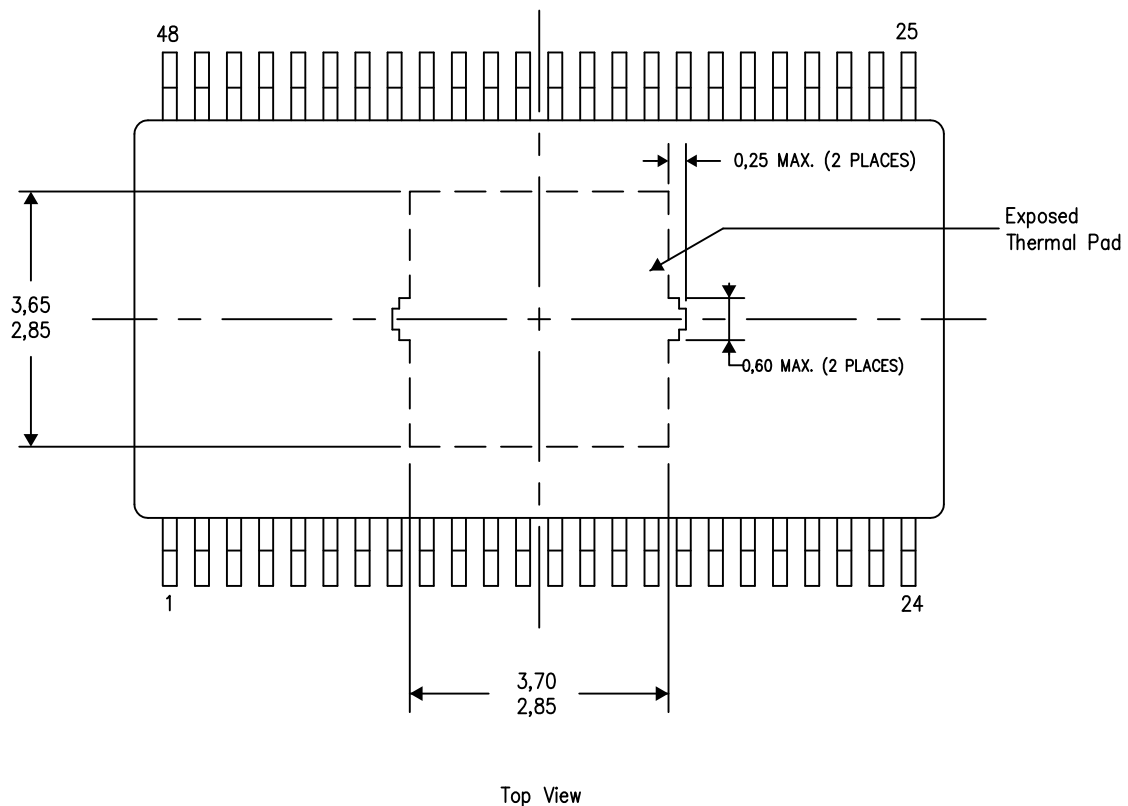

Exposed Thermal Pad Dimensions

4206320-6/S 11/14

NOTE: A. All linear dimensions are in millimeters

PowerPAD is a trademark of Texas Instruments.

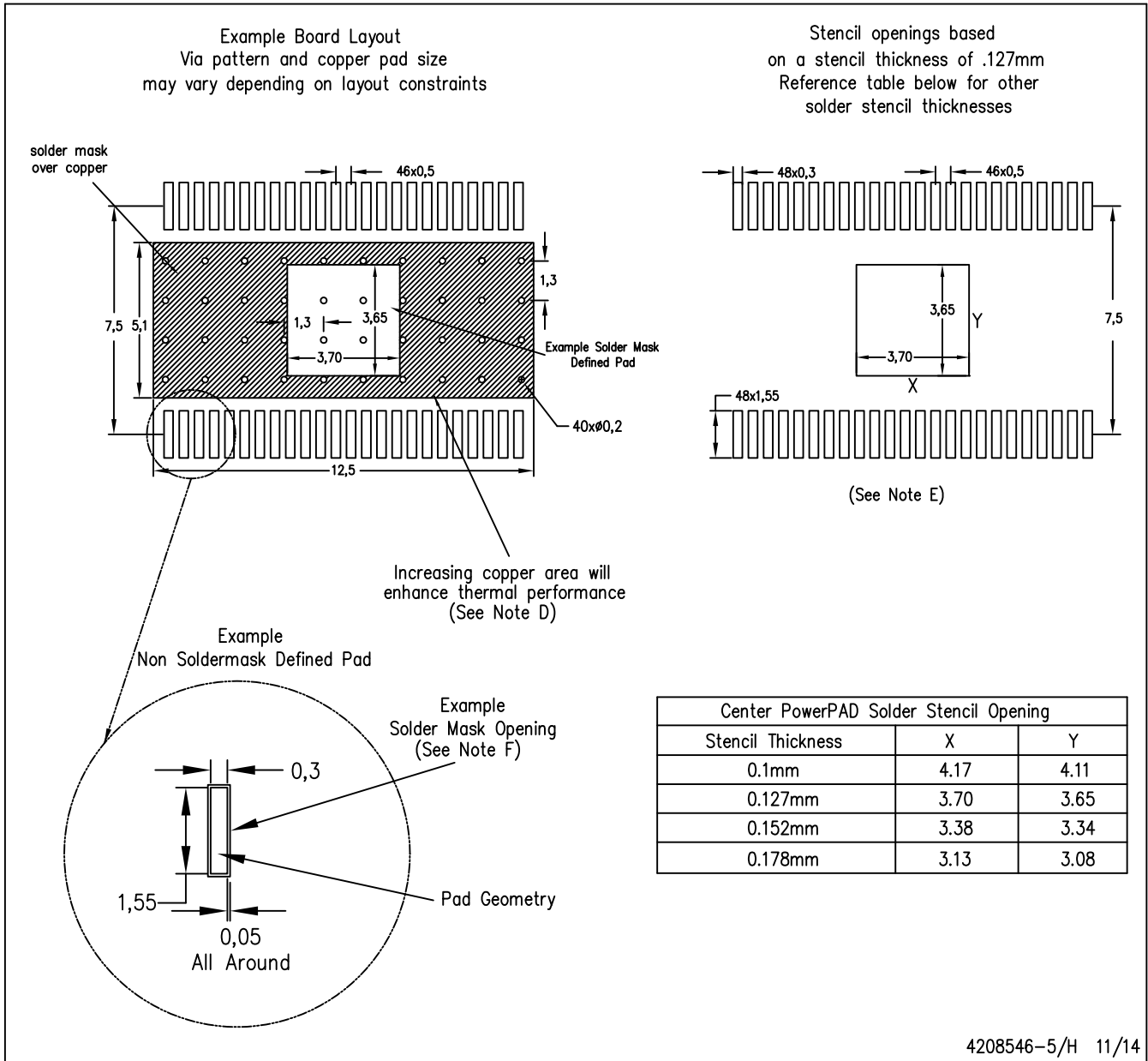

- NOTES:
- A. All linear dimensions are in millimeters.
 - B. This drawing is subject to change without notice.
 - C. Customers should place a note on the circuit board fabrication drawing not to alter the center solder mask defined pad.
 - D. This package is designed to be soldered to a thermal pad on the board. Refer to Technical Brief, PowerPAD Thermally Enhanced Package, Texas Instruments Literature No. SLMA002, SLMA004, and also the Product Data Sheets for specific thermal information, via requirements, and recommended board layout. These documents are available at www.ti.com <<http://www.ti.com>>. Publication IPC-7351 is recommended for alternate designs.
 - E. Laser cutting apertures with trapezoidal walls and also rounding corners will offer better paste release. Customers should contact their board assembly site for stencil design recommendations. Example stencil design based on a 50% volumetric metal load solder paste. Refer to IPC-7525 for other stencil recommendations.
 - F. Customers should contact their board fabrication site for solder mask tolerances between and around signal pads.

IMPORTANT NOTICE AND DISCLAIMER

TI PROVIDES TECHNICAL AND RELIABILITY DATA (INCLUDING DATASHEETS), DESIGN RESOURCES (INCLUDING REFERENCE DESIGNS), APPLICATION OR OTHER DESIGN ADVICE, WEB TOOLS, SAFETY INFORMATION, AND OTHER RESOURCES "AS IS" AND WITH ALL FAULTS, AND DISCLAIMS ALL WARRANTIES, EXPRESS AND IMPLIED, INCLUDING WITHOUT LIMITATION ANY IMPLIED WARRANTIES OF MERCHANTABILITY, FITNESS FOR A PARTICULAR PURPOSE OR NON-INFRINGEMENT OF THIRD PARTY INTELLECTUAL PROPERTY RIGHTS.

These resources are intended for skilled developers designing with TI products. You are solely responsible for (1) selecting the appropriate TI products for your application, (2) designing, validating and testing your application, and (3) ensuring your application meets applicable standards, and any other safety, security, or other requirements. These resources are subject to change without notice. TI grants you permission to use these resources only for development of an application that uses the TI products described in the resource. Other reproduction and display of these resources is prohibited. No license is granted to any other TI intellectual property right or to any third party intellectual property right. TI disclaims responsibility for, and you will fully indemnify TI and its representatives against, any claims, damages, costs, losses, and liabilities arising out of your use of these resources.

TI's products are provided subject to TI's Terms of Sale (www.ti.com/legal/termsofsale.html) or other applicable terms available either on ti.com or provided in conjunction with such TI products. TI's provision of these resources does not expand or otherwise alter TI's applicable warranties or warranty disclaimers for TI products.

Mailing Address: Texas Instruments, Post Office Box 655303, Dallas, Texas 75265
Copyright © 2019, Texas Instruments Incorporated

Looking for pricing, stock, or lifecycle information?

Click below to explore more details on WIN SOURCE:

 [View DRV8823QDCARQ1](#) on WIN SOURCE

 [Texas Instruments](#) Information

Optimize Your Supply Chain with WIN SOURCE Solutions

-  Global Sourcing Solution
-  Obsolete Management
-  Cost Control Management
-  Shortage Management
-  Alternative Solution
-  Excess Inventory Management