



**THE DATASHEET OF
TEA1708T/1J**





TEA1708T

GreenChip X capacitor discharge IC

Rev. 1.1 — 6 April 2020

Product data sheet

1 General description

The TEA1708 is an automatic discharge IC for X capacitors with a low power consumption (typically 1 mW at 230 V (AC)).

A 500 V clamping circuit is integrated, protecting the IC during mains surges. In a typical application with only two 200 k Ω resistors, the maximum differential mode mains surge voltage allowed exceeds 6 kV. A metal-oxide varistor is not required to protect the IC.

The X-capacitor discharge current is internally limited to 2.3 mA. The discharge delay timer is set externally using a low-voltage capacitor.

To reduce EMI while retaining the low standby power, the very low power consumption with a high discharge current enables the use of a high value X-capacitor.

2 Features and benefits

- 1 mW power consumption at 230 V (AC)
- Integrated 500 V clamp; no metal oxide varistor required to protect the IC
- Self-Supplied, no external bias required
- Discharge current internally limited
- Adjustable discharge delay
- Very high differential surge: 6 kV with two 200 k Ω resistors
- Easier application design, resolving EMI issues while retaining the efficiency level

3 Applications

- All AC-connected power supplies with X-capacitors > 100 nF requiring a low load standby power.

4 Ordering information

Table 1. Ordering information

| Type number | Package | | |
|-------------|---------|---|---------|
| | Name | Description | Version |
| TEA1708T/1 | SO8 | plastic small outline package; 8 leads; body width 3.9 mm | SOT96-1 |



5 Marking

Table 2. Marking codes

| Type number | Marking code |
|-------------|--------------|
| TEA1708T/1 | TEA1708 |

6 Block diagram

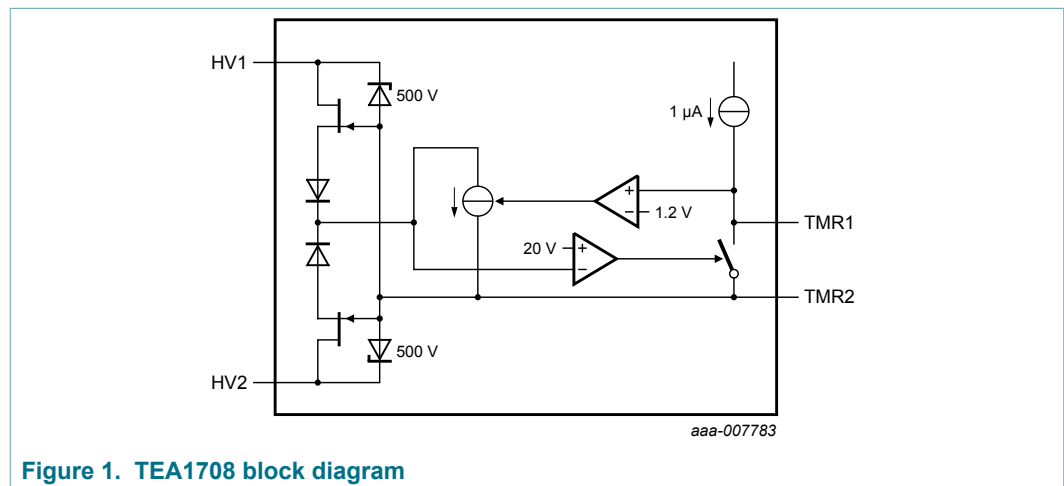

7 Pinning information

7.1 Pinning

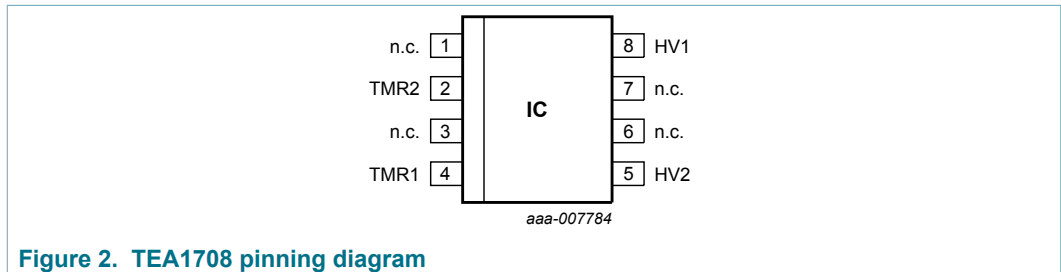

Figure 2. TEA1708 pinning diagram

7.2 Pin description

Table 3. Pin description

| Symbol | Pin | Description |
|--------|-----|---------------------------------|
| n.c. | 1 | not connected |
| TMR2 | 2 | timer pin 2 |
| n.c. | 3 | not connected |
| TMR1 | 4 | timer pin 1 |
| HV2 | 5 | high-voltage mains connection 2 |
| n.c. | 6 | not connected |
| n.c. | 7 | not connected |
| HV1 | 8 | high-voltage mains connection 1 |

8 Functional description

The TEA1708 incorporates a timer and a zero-crossing mains voltage detector. If a positive or negative voltage exceeding the threshold zero-crossing mains voltage (20 V) is applied between the high-voltage pins, the timer charges the external capacitor on the TMR1 and TMR2 pins. If the voltage between the TMR1 and TMR2 pins reaches 1.2 V, a discharge current is activated. If the voltage applied between the high-voltage pins, is below the threshold zero-crossing mains voltage, the external capacitor is discharged and the discharging stops. The discharge current is internally limited.

When an AC mains voltage is applied, the timer capacitor is charged between the mains zero crossings and discharged during the mains zero crossings. When the AC mains is disconnected and a high voltage remains on the X-capacitor, the timer charges the external capacitor above its discharge activation threshold voltage point (1.2 V), switching on the internally limited discharge current of the external X-capacitor.

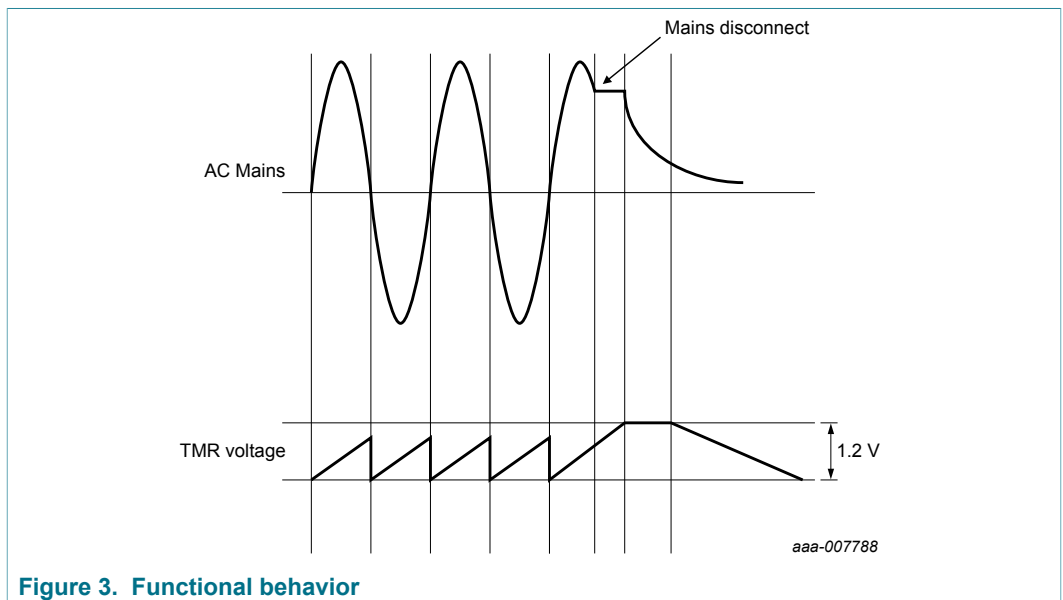

Figure 3. Functional behavior

To protect the IC during mains surges, a high-voltage clamping circuit is integrated. The clamping circuit is activated for positive and negative voltages > 500 V. The high-voltage pins HV1 and HV2 are fully symmetrical.

9 Limiting values

Table 4. Limiting values

In accordance with the Absolute Maximum Rating System (IEC 60134).

| Symbol | Parameter | Conditions | Min | Max | Unit |
|-----------------|---------------------------------------|--|------------------|------|------|
| Voltages | | | | | |
| $V_{TMR1-TMR2}$ | voltage between pin TMR1 and pin TMR2 | $0 \mu A > I_{dch(tmr)} < 10 \mu A$ | -0.4 | +3.5 | V |
| $V_{HV1-HV2}$ | voltage between pin HV1 and pin HV2 | normal operation, so no mains surge | -410 | +410 | V |
| Currents | | | | | |
| I_{HV} | current on pin HV | both HV pins; $t < 2$ ms, during mains surge | -15 | +15 | mA |
| General | | | | | |
| P_{tot} | total power dissipation | $T_{amb} < 75$ °C | - | 0.5 | W |
| T_{stg} | storage temperature | | -55 | +150 | °C |
| T_j | junction temperature | | -40 | +150 | °C |
| ESD | | | | | |
| V_{ESD} | electrostatic discharge voltage | class 1 | | | |
| | | human body model (HBM); pins HV1 and HV2 | ^[1] - | 1000 | V |
| | | human body model(HBM); all other pins | - | 4000 | V |
| | charged device model (CDM); all pins | ^[2] - | 750 | V | |

[1] Equivalent to discharging a 100 pF capacitor through a 1.5 kΩ series resistor.

[2] Equivalent to discharging a 200 pF capacitor through a 0.75 μH coil and a 10 Ω resistor.

10 Thermal characteristics

Table 5. Thermal characteristics

| Symbol | Parameter | Conditions | Typ | Unit |
|---------------|---|-------------------------------|-----|------|
| $R_{th(j-a)}$ | thermal resistance from junction to ambient | in free air; JEDEC test board | 160 | K/W |
| $R_{th(j-c)}$ | thermal resistance from junction to case | in free air; JEDEC test board | 72 | K/W |

11 Characteristics

Table 6. Characteristics

$T_{amb} = 25\text{ }^{\circ}\text{C}$; currents are positive when flowing into the IC; unless otherwise specified.

| Symbol | Parameter | Conditions | Min | Typ | Max | Unit |
|--|--|---|-------|-------|-------|---------------|
| High voltage (pins HV1 and HV2) | | | | | | |
| I_{HV} | current on pin HV | both HV pins; $V_{HV1} > 50\text{ V}$; $V_{HV2} > 50\text{ V}$ | | | | |
| | | $V_{TMR} < 1.2\text{ V}$ | 2.5 | 3.5 | 4.5 | μA |
| | | current limited; $V_{TMR} > 1.2\text{ V}$ | 1.8 | 2.3 | 2.8 | mA |
| V_{clamp} | clamp voltage | | 475 | 500 | 525 | V |
| $V_{th(ch)}$ | charge threshold voltage | threshold zero-crossing mains voltage | 19 | 21 | 23 | V |
| Timer (pins TMR1 and TMR2) | | | | | | |
| $V_{th(act)dch}$ | discharge activation threshold voltage | to discharge the X-capacitor | 1.1 | 1.2 | 1.3 | V |
| $I_{dch(tmr)}$ | timer discharge current | | -1.20 | -0.95 | -0.70 | μA |

12 Application information

The TEA1708 is typically connected across the X-capacitor. A metal-oxide varistor is not required to protect the IC because the device incorporates a high-voltage clamping circuit. The IC is sufficiently protected for differential mode surge voltages up to 4 kV with only two 200 k Ω resistors (see [Figure 4](#)).

The discharge delay time is set externally using a low-voltage capacitor connected between the TMR1 and TMR2 pins. Select a value between 10 nF and 22 nF for a mains frequency of 50 Hz or 60 Hz. The minimum value is 10 nF which gives the smallest delay time. Do not use values < 10 nF. They can lead to unwanted discharge of the X-capacitor.

The delay time (t_d) for discharge can be calculated with [Equation 1](#):

$$t_d = C_{tmr} \times \frac{V_{th(act)dch}}{I_{dch(tmr)}} \tag{1}$$

If the low-voltage capacitor value is 22 nF the delay time is:

$$22\text{ nF} \times \frac{1.2\text{ V}}{1\mu\text{ A}} = 26\text{ ms}$$

When the voltage across the device exceeds the threshold zero-crossing mains voltage, the discharge current is activated. The current is limited to $\approx 2.3\text{ mA}$. When the current < the current limit, I_{HV} is calculated with [Equation 2](#):

$$I_{HV1} = I_{HV2} \approx \frac{V_{xcap(t)} - (V_{th(ch)} + 4\text{ V})}{(R1 + R2)} \tag{2}$$

When the X-capacitor value is 330 nF and $R1 = R2 = 200\text{ k}\Omega$, the capacitor is discharged to a voltage $< 60\text{ V}$ at a mains of 230 V (AC) in 300 ms.

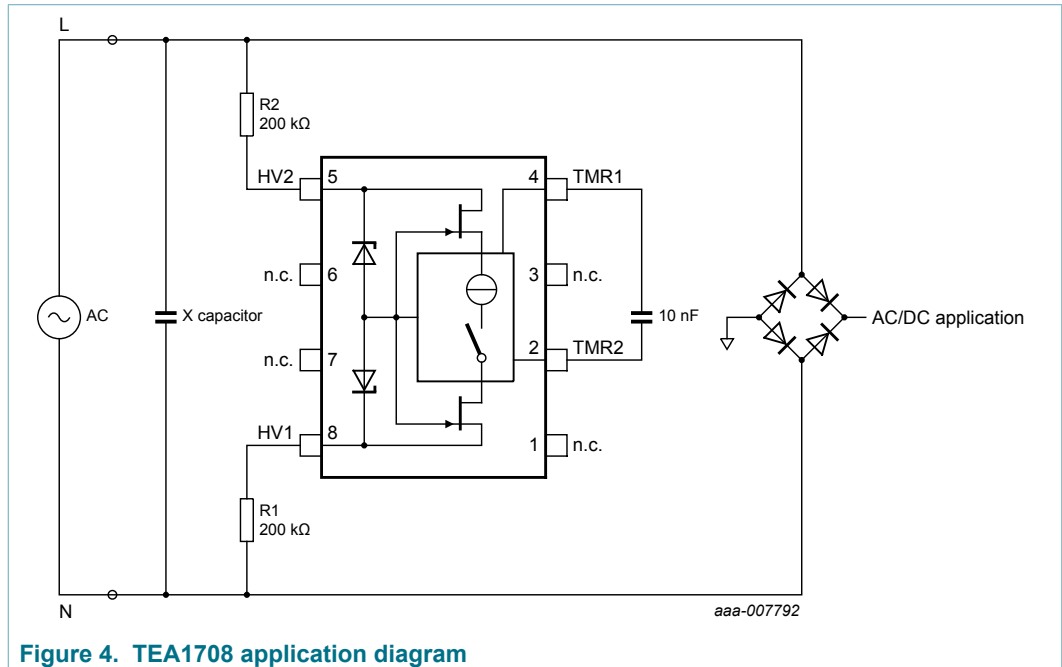

Figure 4. TEA1708 application diagram

To ensure that the capacitor is discharged to a voltage $< 60\text{ V}$ within 2 seconds, use $R1 = R2 = 200\text{ k}\Omega$ for X-capacitor values $< 1.8\text{ }\mu\text{F}$. Lowering $R1 + R2$, for faster discharge or when a higher value for the X-capacitor is required, is possible but it decreases the surge protection level.

13 Package outline

SO8: plastic small outline package; 8 leads; body width 3.9 mm

SOT96-1

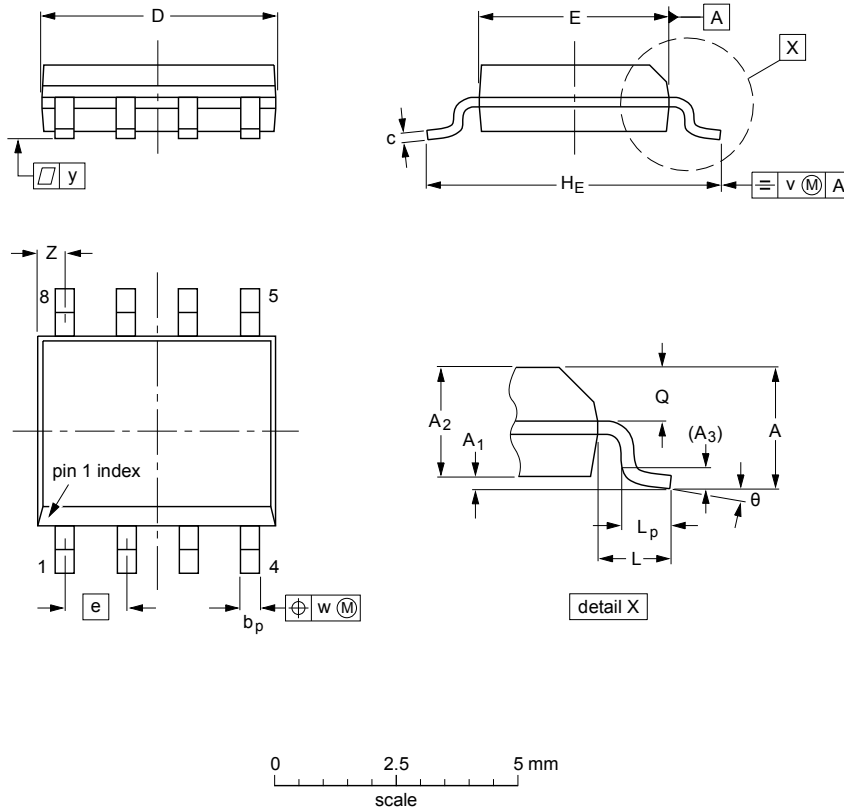

DIMENSIONS (inch dimensions are derived from the original mm dimensions)

| UNIT | A max. | A ₁ | A ₂ | A ₃ | b _p | c | D ⁽¹⁾ | E ⁽²⁾ | e | H _E | L | L _p | Q | v | w | y | Z ⁽¹⁾ | θ |
|--------|--------|----------------|----------------|----------------|----------------|------------------|------------------|------------------|------|----------------|-------|----------------|----------------|------|------|-------|------------------|----------|
| mm | 1.75 | 0.25 0.10 | 1.45 1.25 | 0.25 | 0.49 0.36 | 0.25 0.19 | 5.0 4.8 | 4.0 3.8 | 1.27 | 6.2 5.8 | 1.05 | 1.0 0.4 | 0.7 0.6 | 0.25 | 0.25 | 0.1 | 0.7 0.3 | 8° 0° |
| inches | 0.069 | 0.010 0.004 | 0.057 0.049 | 0.01 | 0.019 0.014 | 0.0100 0.0075 | 0.20 0.19 | 0.16 0.15 | 0.05 | 0.244 0.228 | 0.041 | 0.039 0.016 | 0.028 0.024 | 0.01 | 0.01 | 0.004 | 0.028 0.012 | |

Notes

1. Plastic or metal protrusions of 0.15 mm (0.006 inch) maximum per side are not included.
2. Plastic or metal protrusions of 0.25 mm (0.01 inch) maximum per side are not included.

| OUTLINE VERSION | REFERENCES | | | EUROPEAN PROJECTION | ISSUE DATE |
|-----------------|------------|--------|-------|---------------------|----------------------|
| | IEC | JEDEC | JEITA | | |
| SOT96-1 | 076E03 | MS-012 | | | 99-12-27 03-02-18 |

Figure 5. Package outline SOT96-1 (SO8)

14 Revision history

Table 7. Revision history

| Document ID | Release date | Data sheet status | Change notice | Supersedes |
|------------------|--------------|--------------------|---------------|----------------|
| TEA1708T_1 v.1.1 | 20200406 | Product data sheet | - | TEA1708T_1 v.1 |
| TEA1708T_1 v.1 | 20130925 | Product data sheet | - | - |

15 Legal information

15.1 Data sheet status

| Document status ^{[1][2]} | Product status ^[3] | Definition |
|-----------------------------------|-------------------------------|---|
| Objective [short] data sheet | Development | This document contains data from the objective specification for product development. |
| Preliminary [short] data sheet | Qualification | This document contains data from the preliminary specification. |
| Product [short] data sheet | Production | This document contains the product specification. |

[1] Please consult the most recently issued document before initiating or completing a design.

[2] The term 'short data sheet' is explained in section "Definitions".

[3] The product status of device(s) described in this document may have changed since this document was published and may differ in case of multiple devices. The latest product status information is available on the Internet at URL <http://www.nxp.com>.

15.2 Definitions

Draft — The document is a draft version only. The content is still under internal review and subject to formal approval, which may result in modifications or additions. NXP Semiconductors does not give any representations or warranties as to the accuracy or completeness of information included herein and shall have no liability for the consequences of use of such information.

Short data sheet — A short data sheet is an extract from a full data sheet with the same product type number(s) and title. A short data sheet is intended for quick reference only and should not be relied upon to contain detailed and full information. For detailed and full information see the relevant full data sheet, which is available on request via the local NXP Semiconductors sales office. In case of any inconsistency or conflict with the short data sheet, the full data sheet shall prevail.

Product specification — The information and data provided in a Product data sheet shall define the specification of the product as agreed between NXP Semiconductors and its customer, unless NXP Semiconductors and customer have explicitly agreed otherwise in writing. In no event however, shall an agreement be valid in which the NXP Semiconductors product is deemed to offer functions and qualities beyond those described in the Product data sheet.

15.3 Disclaimers

Limited warranty and liability — Information in this document is believed to be accurate and reliable. However, NXP Semiconductors does not give any representations or warranties, expressed or implied, as to the accuracy or completeness of such information and shall have no liability for the consequences of use of such information. NXP Semiconductors takes no responsibility for the content in this document if provided by an information source outside of NXP Semiconductors. In no event shall NXP Semiconductors be liable for any indirect, incidental, punitive, special or consequential damages (including - without limitation - lost profits, lost savings, business interruption, costs related to the removal or replacement of any products or rework charges) whether or not such damages are based on tort (including negligence), warranty, breach of contract or any other legal theory. Notwithstanding any damages that customer might incur for any reason whatsoever, NXP Semiconductors' aggregate and cumulative liability towards customer for the products described herein shall be limited in accordance with the Terms and conditions of commercial sale of NXP Semiconductors.

Right to make changes — NXP Semiconductors reserves the right to make changes to information published in this document, including without limitation specifications and product descriptions, at any time and without

notice. This document supersedes and replaces all information supplied prior to the publication hereof.

Suitability for use — NXP Semiconductors products are not designed, authorized or warranted to be suitable for use in life support, life-critical or safety-critical systems or equipment, nor in applications where failure or malfunction of an NXP Semiconductors product can reasonably be expected to result in personal injury, death or severe property or environmental damage. NXP Semiconductors and its suppliers accept no liability for inclusion and/or use of NXP Semiconductors products in such equipment or applications and therefore such inclusion and/or use is at the customer's own risk.

Applications — Applications that are described herein for any of these products are for illustrative purposes only. NXP Semiconductors makes no representation or warranty that such applications will be suitable for the specified use without further testing or modification. Customers are responsible for the design and operation of their applications and products using NXP Semiconductors products, and NXP Semiconductors accepts no liability for any assistance with applications or customer product design. It is customer's sole responsibility to determine whether the NXP Semiconductors product is suitable and fit for the customer's applications and products planned, as well as for the planned application and use of customer's third party customer(s). Customers should provide appropriate design and operating safeguards to minimize the risks associated with their applications and products. NXP Semiconductors does not accept any liability related to any default, damage, costs or problem which is based on any weakness or default in the customer's applications or products, or the application or use by customer's third party customer(s). Customer is responsible for doing all necessary testing for the customer's applications and products using NXP Semiconductors products in order to avoid a default of the applications and the products or of the application or use by customer's third party customer(s). NXP does not accept any liability in this respect.

Limiting values — Stress above one or more limiting values (as defined in the Absolute Maximum Ratings System of IEC 60134) will cause permanent damage to the device. Limiting values are stress ratings only and (proper) operation of the device at these or any other conditions above those given in the Recommended operating conditions section (if present) or the Characteristics sections of this document is not warranted. Constant or repeated exposure to limiting values will permanently and irreversibly affect the quality and reliability of the device.

Terms and conditions of commercial sale — NXP Semiconductors products are sold subject to the general terms and conditions of commercial sale, as published at <http://www.nxp.com/profile/terms>, unless otherwise agreed in a valid written individual agreement. In case an individual agreement is concluded only the terms and conditions of the respective agreement shall apply. NXP Semiconductors hereby expressly objects to applying the customer's general terms and conditions with regard to the purchase of NXP Semiconductors products by customer.

No offer to sell or license — Nothing in this document may be interpreted or construed as an offer to sell products that is open for acceptance or the grant, conveyance or implication of any license under any copyrights, patents or other industrial or intellectual property rights.

Export control — This document as well as the item(s) described herein may be subject to export control regulations. Export might require a prior authorization from competent authorities.

Non-automotive qualified products — Unless this data sheet expressly states that this specific NXP Semiconductors product is automotive qualified, the product is not suitable for automotive use. It is neither qualified nor tested in accordance with automotive testing or application requirements. NXP Semiconductors accepts no liability for inclusion and/or use of non-automotive qualified products in automotive equipment or applications. In the event that customer uses the product for design-in and use in automotive applications to automotive specifications and standards, customer (a) shall use the product without NXP Semiconductors' warranty of the product for such automotive applications, use and specifications, and (b) whenever customer uses the product for automotive applications beyond NXP Semiconductors' specifications such use shall be solely at customer's own risk, and (c) customer fully indemnifies NXP Semiconductors for any liability, damages or failed product claims resulting from customer design and use

of the product for automotive applications beyond NXP Semiconductors' standard warranty and NXP Semiconductors' product specifications.

Translations — A non-English (translated) version of a document is for reference only. The English version shall prevail in case of any discrepancy between the translated and English versions.

Security — While NXP Semiconductors has implemented advanced security features, all products may be subject to unidentified vulnerabilities. Customers are responsible for the design and operation of their applications and products to reduce the effect of these vulnerabilities on customer's applications and products, and NXP Semiconductors accepts no liability for any vulnerability that is discovered. Customers should implement appropriate design and operating safeguards to minimize the risks associated with their applications and products.

15.4 Trademarks

Notice: All referenced brands, product names, service names and trademarks are the property of their respective owners.

GreenChip — is a trademark of NXP B.V.

Contents

1 General description 1

2 Features and benefits1

3 Applications1

4 Ordering information 1

5 Marking2

6 Block diagram 2

7 Pinning information 3

7.1 Pinning3

7.2 Pin description 3

8 Functional description4

9 Limiting values5

10 Thermal characteristics5

11 Characteristics 6

12 Application information6

13 Package outline8

14 Revision history 9

15 Legal information 10

Please be aware that important notices concerning this document and the product(s) described herein, have been included in section 'Legal information'.

© NXP B.V. 2020.

All rights reserved.

For more information, please visit: <http://www.nxp.com>

For sales office addresses, please send an email to: salesaddresses@nxp.com

Date of release: 6 April 2020
 Document identifier: TEA1708T

Looking for pricing, stock, or lifecycle information?

Click below to explore more details on WIN SOURCE:

- ⊖ [View TEA1708T/1J on WIN SOURCE](#)
- ⊖ [NXP / Nexperia Information](#)

Optimize Your Supply Chain with WIN SOURCE Solutions

- ✓ Global Sourcing Solution
- ✓ Obsolete Management
- ✓ Cost Control Management
- ✓ Shortage Management
- ✓ Alternative Solution
- ✓ Excess Inventory Management