

AM26LV32 Low-Voltage, High-Speed Quadruple Differential Line Receiver

1 Features

- Switching rates up to 32 MHz
- Operates from single 3.3-V supply
- Ultra-low power dissipation: 27 mW typical
- Open-circuit, short-circuit, and terminated fail-safe
- -0.3-V to 5.5-V Common-mode range with $\pm 200\text{-mV}$ sensitivity
- Accepts 5-V logic inputs with 3.3-V V_{CC}
- Input hysteresis: 50 mV typical
- 235 mW With four receivers at 32 MHz
- Pin-to-pin compatible with AM26C32 and AM26LS32

2 Applications

- High-reliability automotive applications
- Factory automation
- ATM and cash counters
- Smart grid
- AC and servo motor drives

3 Description

The AM26LV32 device is a BiCMOS, quadruple differential line receiver with 3-state outputs, which is designed to be similar to the TIA/EIA-422-B and ITU Recommendation V.11 receivers with reduced common-mode voltage range due to reduced supply voltage.

The device is optimized for balanced bus transmission at switching rates up to 32 MHz. The enable function is common to all four receivers and offers a choice of active-high or active-low inputs. The 3-state outputs permit connection directly to a bus-organized system. Each device features high input impedance, input hysteresis for increased noise immunity, and input sensitivity of $\pm 200\text{ mV}$ over a common-mode input voltage range from -0.3 V to 5.5 V . When the inputs are open-circuit, the outputs are in the high logic state.

The AM26LV32C is characterized for operation from 0°C to 70°C . The AM26LV32I is characterized for operation from -40°C to 85°C .

Package Information

PART NUMBER	PACKAGE ⁽¹⁾	PACKAGE SIZE ⁽²⁾
AM26LV32	SOIC (16)	9.9 mm × 6 mm
	SO (16)	10.2 mm × 7.8 mm

(1) For all available packages, see the orderable addendum at the end of the data sheet.

(2) The package size (length × width) is a nominal value and includes pins, where applicable.

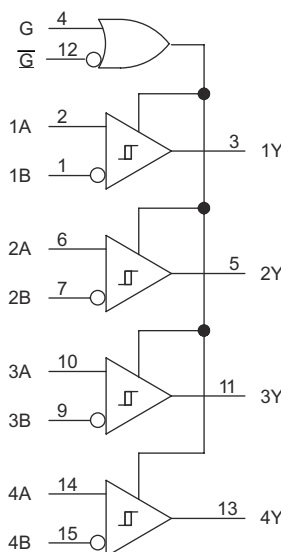

Logic Diagram (Positive Logic)



Table of Contents

1 Features	1	8.2 Functional Block Diagram.....	10
2 Applications	1	8.3 Feature Description.....	10
3 Description	1	8.4 Device Functional Modes.....	11
4 Revision History	2	9 Application and Implementation	18
5 Pin Configuration and Functions	3	9.1 Application Information.....	18
6 Specifications	4	9.2 Typical Application.....	18
6.1 Absolute Maximum Ratings.....	4	9.3 Power Supply Recommendations.....	19
6.2 ESD Ratings.....	4	9.4 Layout.....	19
6.3 Recommended Operating Conditions.....	4	10 Device and Documentation Support	21
6.4 Thermal Information.....	5	10.1 Receiving Notification of Documentation Updates.....	21
6.5 Electrical Characteristics.....	5	10.2 Support Resources.....	21
6.6 Switching Characteristics.....	6	10.3 Trademarks.....	21
6.7 Typical Characteristics.....	7	10.4 Electrostatic Discharge Caution.....	21
7 Parameter Measurement Information	8	10.5 Glossary.....	21
8 Detailed Description	10	11 Mechanical, Packaging, and Orderable Information	21
8.1 Overview.....	10		

4 Revision History

NOTE: Page numbers for previous revisions may differ from page numbers in the current version.

Changes from Revision G (October 2017) to Revision H (August 2023)	Page
• Changed the Device Information table to the <i>Package Information</i> table.....	1
• Changed the AM26LV32I temperature from: –45°C to 85°C to: –40°C to 85°C in the <i>Description</i>	1
• Changed the <i>Thermal Information</i> table.....	5
• Changed the <i>Typical Characteristics</i>	7
Changes from Revision F (November 2016) to Revision G (October 2017)	Page
• Changed the MAX value of $t_{sk(p)}$ From: 6 ns To: 14 ns in the <i>Switching Characteristics</i> table.....	6
• Changed the MAX value of $t_{sk(o)}$ From: 6 ns To: 14 ns in the <i>Switching Characteristics</i> table.....	6
Changes from Revision E (June 2005) to Revision F (November 2016)	Page
• Added <i>ESD Ratings</i> table, <i>Thermal Information</i> table, <i>Feature Description</i> section, <i>Device Functional Modes</i> , <i>Application and Implementation</i> section, <i>Power Supply Recommendations</i> section, <i>Layout</i> section, <i>Device and Documentation Support</i> section, and <i>Mechanical, Packaging, and Orderable Information</i> section.....	1
• Deleted MB570 from <i>Features</i> list.....	1
• Deleted <i>Ordering Information</i> table; see <i>Mechanical, Packaging, and Orderable Information</i> at the end of the data sheet.....	1
• Deleted Lead temperature (260°C maximum) from <i>Absolute Maximum Ratings</i> table.....	4
• Changed Package thermal impedance, $R_{\theta JA}$, values in <i>Thermal Information</i> table From: 73°C To: 72.9°C (D) and From: 64°C To: 74°C (NS).....	5

5 Pin Configuration and Functions

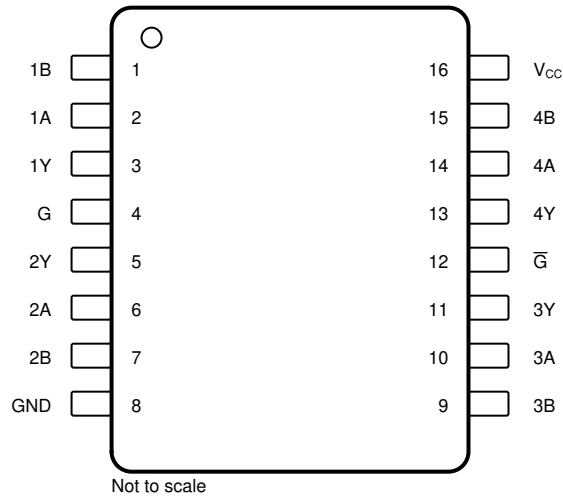

Figure 5-1. D and NS Package, 16-Pin SOIC and SO (Top View)

Table 5-1. Pin Functions

PIN		I/O	DESCRIPTION
NAME	NO.		
1A	2	I	RS422, RS485 differential input (noninverting)
1B	1	I	RS422, RS485 differential input (inverting)
1Y	3	O	Logic level output
2A	6	I	RS422, RS485 differential input (noninverting)
2B	7	I	RS422, RS485 differential input (inverting)
2Y	5	O	Logic level output
3A	10	I	RS422, RS485 differential input (noninverting)
3B	9	I	RS422, RS485 differential input (inverting)
3Y	11	O	Logic level output
4A	14	I	RS422, RS485 differential input (noninverting)
4B	15	I	RS422, RS485 differential input (inverting)
4Y	13	O	Logic level output
\bar{G}	12	I	Active-low select
G	4	I	Active-high select
GND	8	—	Ground
V _{CC}	16	—	Power supply

6 Specifications

6.1 Absolute Maximum Ratings

Over operating free-air temperature range (unless otherwise noted)⁽¹⁾

	MIN	MAX	UNIT
Supply voltage, V_{CC} ⁽²⁾	-0.3	6	V
Input voltage, V_I	-4	8	V
Differential input voltage, V_{ID} ⁽³⁾		±12	V
Enable input voltage	-0.3	6	V
Output voltage, V_O	-0.3	6	V
Maximum output current, I_O		±25	mA
Storage temperature, T_{stg}	-65	150	°C

- (1) Stresses beyond those listed under *Absolute Maximum Ratings* may cause permanent damage to the device. These are stress ratings only, which do not imply functional operation of the device at these or any other conditions beyond those indicated under *Recommended Operating Conditions*. Exposure to absolute-maximum-rated conditions for extended periods may affect device reliability.
- (2) All voltage values are with respect to the GND terminal.
- (3) Differential input voltage is measured at the noninverting input with respect to the corresponding inverting input.

6.2 ESD Ratings

		VALUE	UNIT
$V_{(ESD)}$ Electrostatic discharge	Human-body model (HBM), per ANSI/ESDA/JEDEC JS-001 ⁽¹⁾	±500	V
	Charged-device model (CDM), per JEDEC specification JESD22-C101 ⁽²⁾	±500	

- (1) JEDEC document JEP155 states that 500-V HBM allows safe manufacturing with a standard ESD control process.
- (2) JEDEC document JEP157 states that 250-V CDM allows safe manufacturing with a standard ESD control process.

6.3 Recommended Operating Conditions

over operating free-air temperature range (unless otherwise noted)

		MIN	NOM	MAX	UNIT
Supply voltage, V_{CC}		3	3.3	3.6	V
High-level input voltage, $V_{IH(EN)}$		2			V
Low-level input voltage, $V_{IL(EN)}$				0.8	V
Common-mode input voltage, V_{IC}		-0.3		5.5	V
Differential input voltage, V_{ID}				±5.8	V
High-level output current, I_{OH}				-5	mA
Low-level output current, I_{OL}				5	mA
Operating free-air temperature, T_A	AM26LV32C	0		70	°C
	AM26LV32I	-40		85	

6.4 Thermal Information

THERMAL METRIC ^{(1) (2)}		AM26LV32				UNIT
		D (SOIC)	DR (SOIC-Reel)	NS (SO)	NSR (SO-Reel)	
		16 PINS	16 PINS	16 PINS	16 PINS	
R _{θJA}	Junction-to-ambient thermal resistance	72.9	84.6	74	88.5	°C/W
R _{θJC(top)}	Junction-to-case (top) thermal resistance	32.4	43.5	31.1	46.2	°C/W
R _{θJB}	Junction-to-board thermal resistance	30.4	43.2	34.8	50.7	°C/W
ψ _{JT}	Junction-to-top characterization parameter	5.4	10.4	5.1	13.5	°C/W
ψ _{JB}	Junction-to-board characterization parameter	30.1	42.8	34.5	50.3	°C/W

- (1) For more information about traditional and new thermal metrics, see the [Semiconductor and IC Package Thermal Metrics](#) application report.
- (2) The package thermal impedance is calculated in accordance with JESD 51.

6.5 Electrical Characteristics

over operating free-air temperature range (unless otherwise noted)

PARAMETER		TEST CONDITIONS	MIN	TYP ⁽¹⁾	MAX	UNIT
V _{IT+}	Differential input high-threshold voltage				0.2	V
V _{IT-}	Differential input low-threshold voltage		-0.2			V
V _{IK}	Enable input clamp voltage	I _I = -18 mA		-0.8	-1.5	V
V _{OH}	High-level output voltage	V _{ID} = 200 mV, I _{OH} = -5 mA	2.4	3.2		V
V _{OL}	Low-level output voltage	V _{ID} = 200 mV, I _{OH} = 5 mA		0.17	0.5	V
I _{OZ}	High-impedance-state output current	V _O = 0 to V _{CC}			±50	μA
I _{IH(E)}	High-level enable input current	V _{CC} = 0 or 3 V, V _I = 5.5 V			10	μA
I _{IL(E)}	Low-level enable input current	V _{CC} = 3.6 V, V _I = 0 V			-10	μA
r _I	Input resistance		7	12		kΩ
I _I	Input current	V _I = 5.5 V or -0.3 V, all other inputs GND			±700	μA
I _{CC}	Supply current	V _{I(E)} = V _{CC} or GND, no load, line inputs open		8	17	mA
C _{pd}	Power dissipation capacitance ⁽²⁾	One channel		150		pF

- (1) All typical values are at V_{CC} = 3.3 V and T_A = 25°C.
- (2) C_{pd} determines the no-load dynamic current: I_S = C_{pd} × V_{CC} × f + I_{CC}.

6.6 Switching Characteristics

over operating free-air temperature range (unless otherwise noted)

PARAMETER		TEST CONDITIONS	MIN	TYP	MAX	UNIT
t_{PLH}	Propagation delay time, low- to high-level output	See Figure 7-1	8	16	20	ns
t_{PHL}	Propagation delay time, high- to low-level output	See Figure 7-1	8	16	20	ns
t_t	Transition time (t_r or t_f)	See Figure 7-1		5		ns
t_{PZH}	Output-enable time to high level	See Figure 7-2		17	40	ns
t_{PZL}	Output-enable time to low level	See Figure 7-3		10	40	ns
t_{PHZ}	Output-disable time from high level	See Figure 7-2		20	40	ns
t_{PLZ}	Output-disable time from low level	See Figure 7-3		16	40	ns
$t_{sk(p)}$ ⁽¹⁾	Pulse skew			4	14	ns
$t_{sk(o)}$ ⁽²⁾	Pulse skew			4	14	ns
$t_{sk(pp)}$ ⁽³⁾	Pulse skew (device to device)			6	9	ns

(1) $t_{sk(p)}$ is $|t_{PLH} - t_{PHL}|$ of each channel of the same device.

(2) $t_{sk(o)}$ is the maximum difference in propagation delay times between any two channels of the same device switching in the same direction.

(3) $t_{sk(pp)}$ is the maximum difference in propagation delay times between any two channels of any two devices switching in the same direction.

6.7 Typical Characteristics

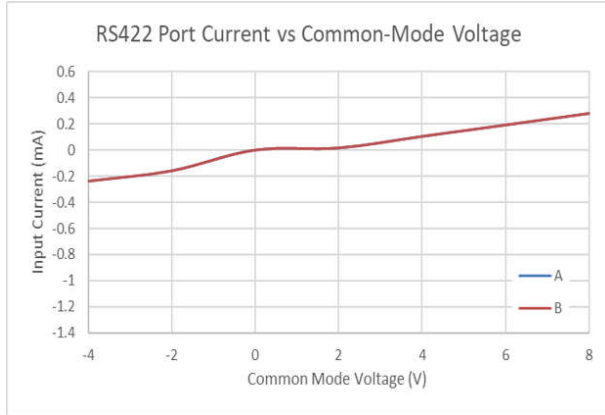

Figure 6-1. RS422 Port Current vs Common-Mode Voltage

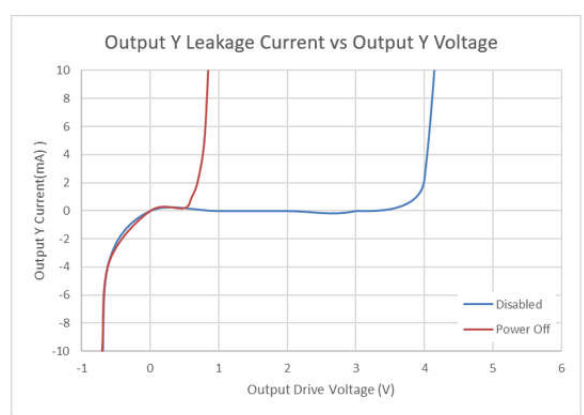

Figure 6-2. Output Y Leakage Current vs Output Y Voltage

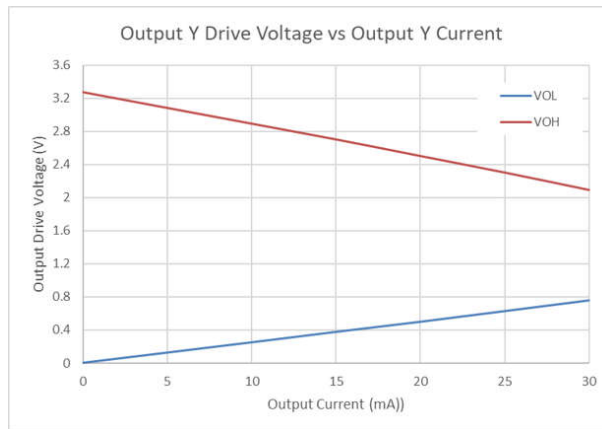
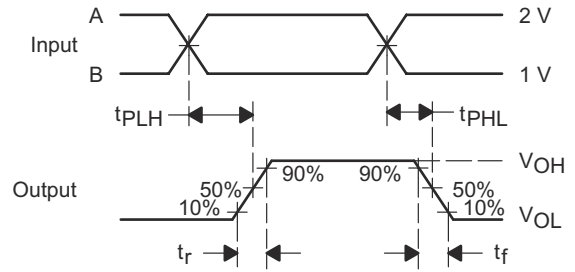
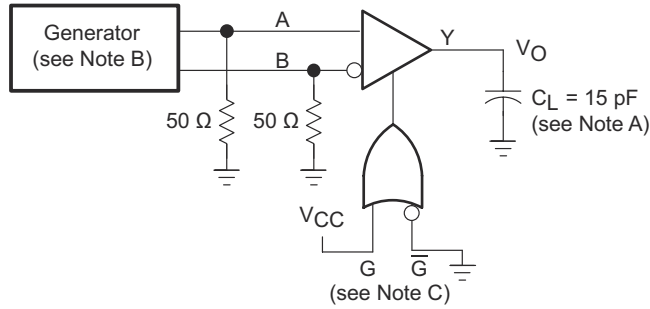

Figure 6-3. Output Y Drive Voltage vs Output Y Current

7 Parameter Measurement Information



- A. C_L includes probe and jig capacitance.
- B. The input pulse is supplied by a generator having the following characteristics: $Z_O = 50 \Omega$, PRR = 10 MHz, t_r and t_f (10% to 90%) ≤ 2 ns, 50% duty cycle.
- C. To test the active-low enable \bar{G} , ground G and apply an inverted waveform \bar{G} .

Figure 7-1. t_{PLH} and t_{PHL} Test Circuit and Voltage Waveforms

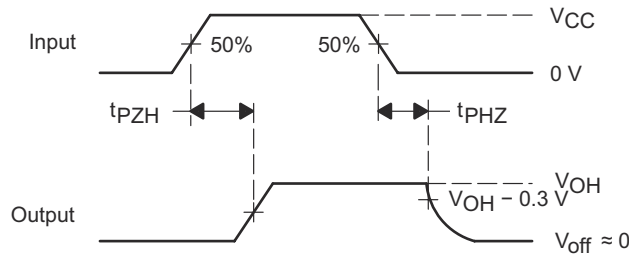
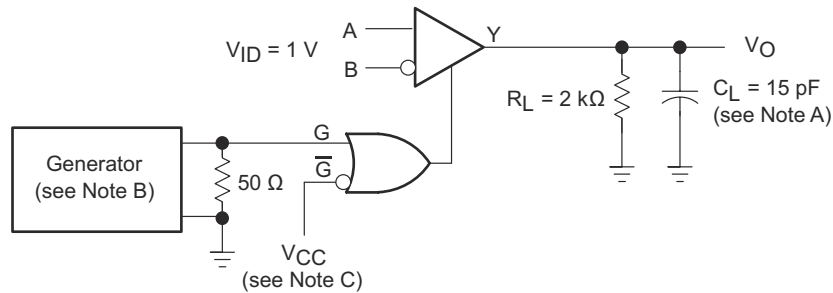

- A. C_L includes probe and jig capacitance.
- B. The input pulse is supplied by a generator having the following characteristics: $Z_O = 50 \Omega$, PRR = 10 MHz, t_r and t_f (10% to 90%) ≤ 2 ns, 50% duty cycle.
- C. To test the active-low enable \bar{G} , ground G and apply an inverted waveform \bar{G} .

Figure 7-2. t_{PZH} and t_{PHZ} Test Circuit and Voltage Waveforms

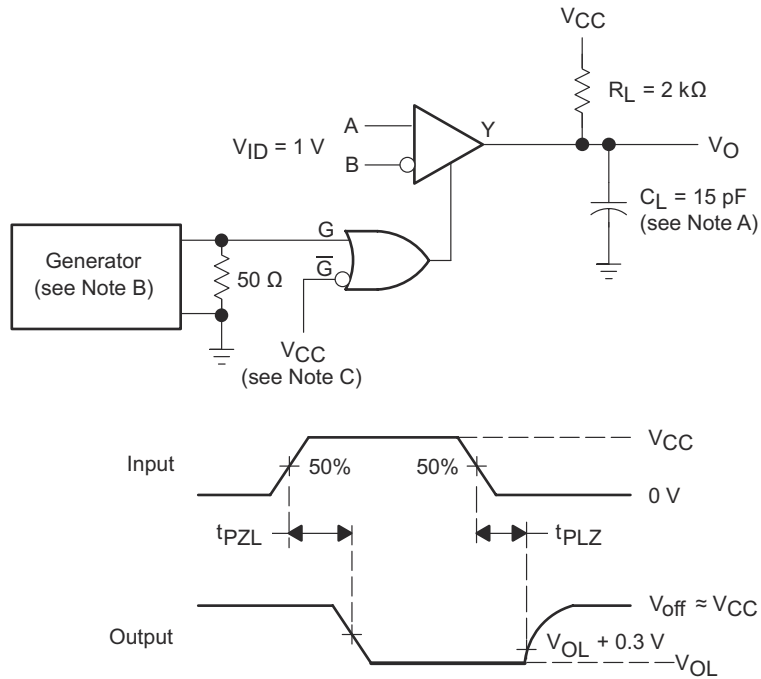

- A. C_L includes probe and jig capacitance.
- B. The input pulse is supplied by a generator having the following characteristics: $Z_O = 50\ \Omega$, PRR = 10 MHz, t_r and t_f (10% to 90%) $\leq 2\ \text{ns}$, 50% duty cycle.
- C. To test the active-low enable \overline{G} , ground G and apply an inverted waveform \overline{G} .

Figure 7-3. t_{PZL} and t_{PLZ} Test Circuit and Voltage Waveforms

8 Detailed Description

8.1 Overview

The AM26LV32 device is a quadruple differential line receiver that meets the necessary requirements for NSI TIA/EIA-422-B, TIA/EIA-423-B, and ITU Recommendation V.10 and V.11. This device allows a low-power or low-voltage MCU to interface with heavy machinery, subsystems, and other devices through long wires of up to 1000 m, giving any design a reliable and easy-to-use connection. As with any RS422 interface, the AM26LV32 works in a differential voltage range, which enables very good signal integrity.

8.2 Functional Block Diagram

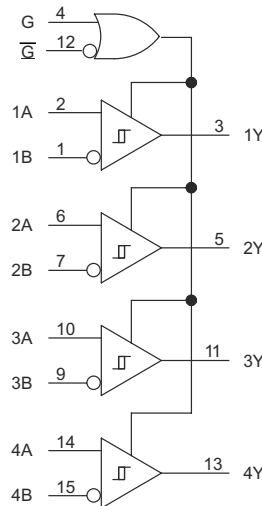
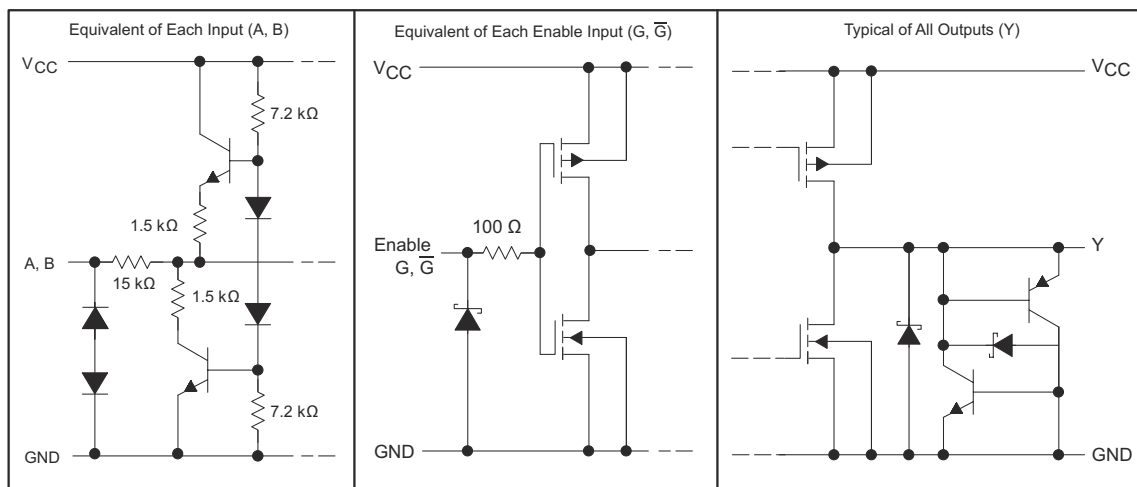

Figure 8-1. Logic Diagram (Positive Logic)

8.3 Feature Description

The device can be configured using the G and \bar{G} logic inputs to select receiver output. The high voltage or logic 1 on the G pin allows the device to operate on an active-high, and having a low voltage or logic 0 on the \bar{G} enables active-low operation. These are simple ways to configure the logic to match that of the receiving or transmitting controller or microprocessor.



Copyright © 2016, Texas Instruments Incorporated

Figure 8-2. Schematics of Equivalent Inputs and Outputs

8.4 Device Functional Modes

The receivers implemented in these RS422 devices can be configured using the G and \bar{G} logic pins to be enabled or disabled. This allows the option to ignore or filter out transmissions as desired. [Table 8-1](#) lists the function of each receiver.

Table 8-1. Function Table (Each Receiver)

DIFFERENTIAL INPUT	ENABLES		OUTPUT ⁽¹⁾
	G	\bar{G}	
$V_{ID} \geq 0.2 \text{ V}$	H	X	H
	X	L	H
$-0.2 \text{ V} < V_{ID} < 0.2 \text{ V}$	H	X	?
	X	L	?
$V_{ID} \leq -0.2 \text{ V}$	H	X	L
	X	L	L
Open, shorted, or terminated ⁽²⁾	H	X	H
	X	L	H
X	L	H	Z

(1) H = high level, L = low level, X = irrelevant, Z = high impedance (off), ? = indeterminate

(2) See [Section 9](#) section

8.4.1 Fail-Safe Conditions

The AM26LV32 is a quadruple differential line receiver that is designed to function properly when appropriately connected to active drivers. Applications do not always have ideal situations where all bits are being used, the receiver inputs are never left floating, and fault conditions do not exist. In actuality, most applications have the capability to either place the drivers in a high-impedance mode or power down the drivers altogether, and cables may be purposely (or inadvertently) disconnected, both of which lead to floating receiver inputs. Furthermore, even though measures are taken to avoid fault conditions like a short between the differential signals, this does occur. The AM26LV32 device has an internal fail-safe circuitry which prevents the device from putting an unknown voltage signal at the receiver outputs. In the following three cases, a high-state is produced at the respective output:

1. Open fail-safe: Unused input pins are left open. Do not tie unused pins to ground or any other voltage. Internal circuitry places the output in the high state.
2. 100- Ω terminated fail-safe: Disconnected cables, drivers in high-impedance state, or powered-down drivers does not cause the AM26LV32 to malfunction. The outputs remain in a high state under these conditions. When the drivers are either turned-off or placed into the high-impedance state, the receiver input may still be able to pick up noise due to the cable acting as an antenna. To avoid having a large differential voltage being generated, the use of twisted-pair cable induces the noise as a common-mode signal and is rejected.
3. Shorted fail-safe: Fault conditions that short the differential input pairs together does not cause incorrect data at the outputs. A differential voltage (V_{ID}) of 0 V forces a high state at the outputs. Shorted fail-safe, however, is not supported across the recommended common-mode input voltage (V_{IC}) range. An unwanted state can be induced to all outputs when an input is shorted and is biased with a voltage between -0.3 V and $+5.5 \text{ V}$. The shorted fail-safe circuitry functions properly when an input is shorted, but with no external common-mode voltage applied.

8.4.2 Fail-Safe Precautions

The internal fail-safe circuitry was designed such that the input common-mode (V_{IC}) and differential (V_{ID}) voltages must be observed. To ensure the outputs of unused or inactive receivers remain in a high state when the inputs are open-circuited, shorted, or terminated, extra precaution must be taken on the active signal. In applications where the drivers are placed in a high-impedance mode or are powered-down, TI recommends that for 1, 2, or 3 active receiver inputs, the low-level input voltage (V_{IL}) must be greater than 0.4 V. As in all data transmission applications, it is necessary to provide a return ground path between the two remote grounds (driver and receiver ground references) to avoid ground differences. [Table 8-2](#) and [Figure 8-3](#) through [Figure 8-5](#)

are examples of active input voltages with their respective waveforms and the effect each have on unused or inactive outputs. Note that the active receivers behave as expected, regardless of the input levels.

Table 8-2. Active Receiver Inputs vs Outputs

1, 2, OR 3 ACTIVE INPUTS			SEE FIGURE	1, 2, OR 3 ACTIVE OUTPUTS	3, 2, OR 1 UNUSED OR INACTIVE OUTPUTS
V_{IL}	V_{ID}	V_{IC}			
900 mV	200 mV	1 V	Figure 8-3	Known state	High state
-100 mV	200 mV	0 V	Figure 8-4	Known state	?
600 mV	800 mV	1 V	Figure 8-5	Known state	High state
0 mV	800 mV	400 mV	Figure 8-6	Known state	?

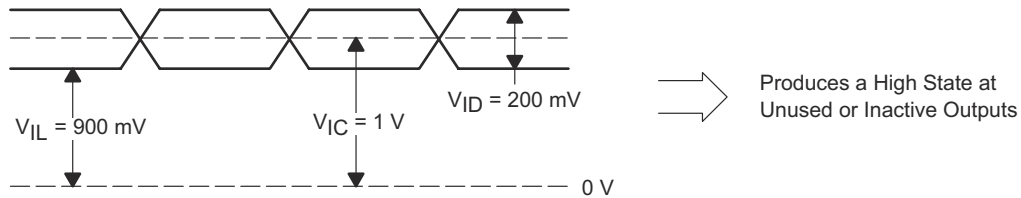

Figure 8-3. Waveform 1

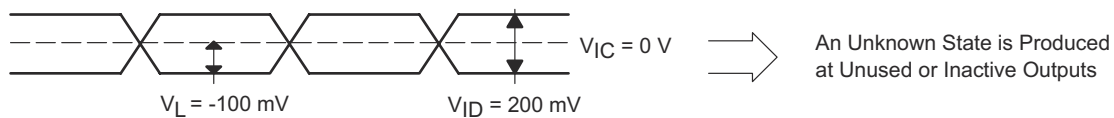

Figure 8-4. Waveform 2

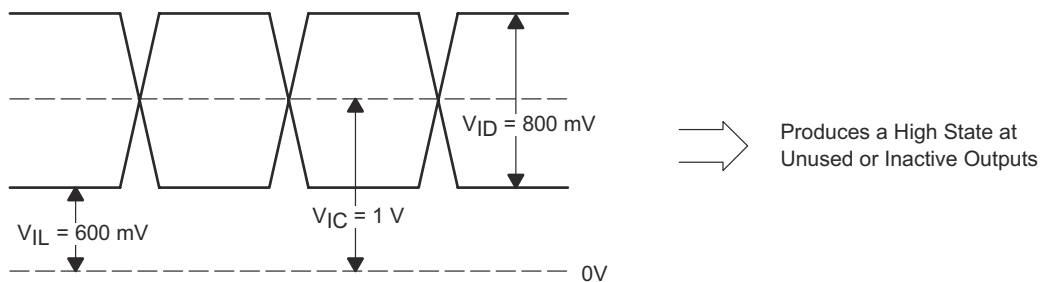

Figure 8-5. Waveform 3

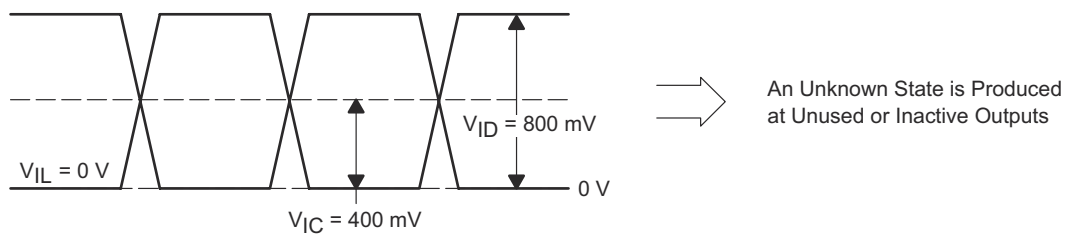

Figure 8-6. Waveform 4

In most applications, having a common-mode input close to ground and a differential voltage larger than 2 V is not customary. Because the common-mode input voltage is typically around 1.5 V, a 2-V V_{ID} would result in a V_{IL} of 0.5 V, thus satisfying the recommended V_{IL} level of greater than 0.4 V.

Figure 8-7 plots seven different input threshold curves from a variety of production lots and shows how the fail-safe circuitry behaves with the input common-mode voltage levels. These input threshold curves are representative samples of production devices. The curves specifically illustrate a typical range of input threshold variation. The AM26LV32 is specified with ± 200 mV of input sensitivity to account for the variance in input threshold. Each data point represents the input's ability to produce a known state at the output for a given V_{IC} .

and V_{ID} . Applying a differential voltage at or above a certain point on a curve would produce a known state at the output. Applying a differential voltage less than a certain point on a curve would activate the fail-safe circuit and the output would be in a high state. For example, inspecting the top input threshold curve reveals that for a V_{IC} that is approximately 1.6 V, V_{ID} yields around 87 mV. Applying 90 mV of differential voltage to this particular production lot generates a known receiver output voltage. Applying a V_{ID} of 80 mV activates the input fail-safe circuitry and the receiver output is placed in the high state. Texas Instruments specifies the input threshold at ± 200 mV, because normal process variations affect this parameter. Note that at common-mode input voltages around 0.2 V, the input differential voltages are low compared to their respective data points. This phenomenon points to the fact that the inputs are very sensitive to small differential voltages around 0.2 V V_{IC} . TI recommends that V_{IC} levels be kept greater than 0.5 V to avoid this increased sensitivity at $V_{IC} \approx 0.2$ V. In most applications, because V_{IC} typically is 1.5 V, the fail-safe circuitry functions properly to provide a high state at the receiver output.

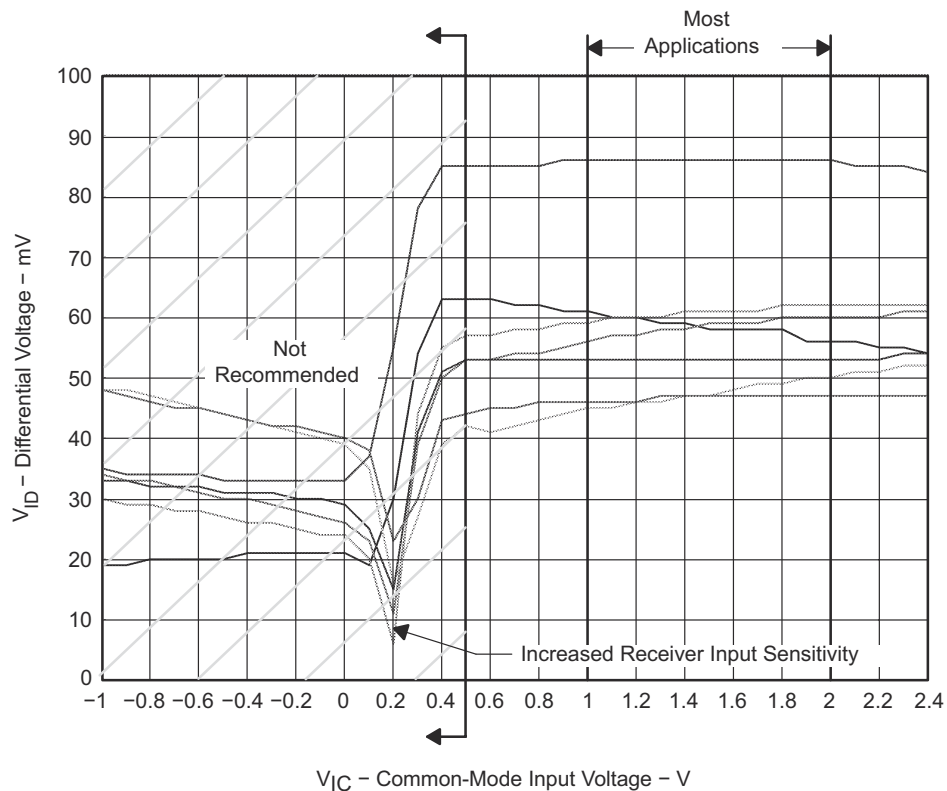

Figure 8-7. V_{IC} vs V_{ID} Receiver Sensitivity Levels

Figure 8-8 represents a typical application where two receivers are not used. In this case, there is no need to worry about the output voltages of the unused receivers because these are not connected in the system architecture.

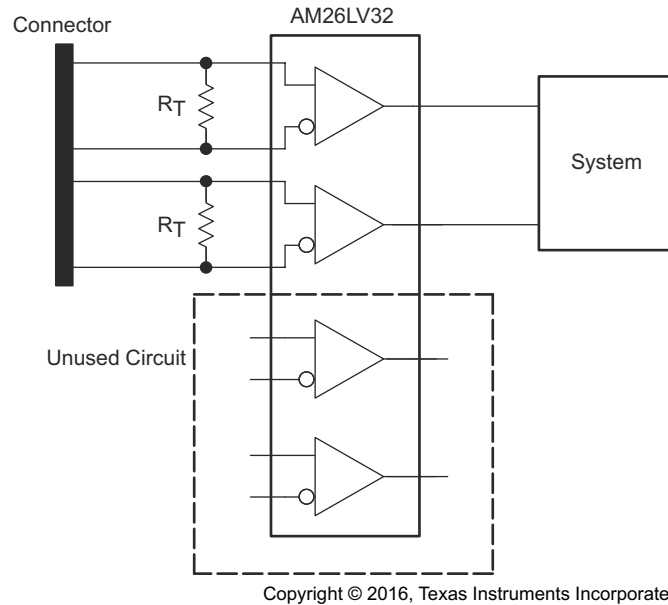

Figure 8-8. Typical Application With Unused Receivers

Figure 8-9 shows a common application where one or more drivers are either disabled or powered down. To ensure the inactive receiver outputs are in a high state, the active receiver inputs must have $V_{IL} > 0.4\text{ V}$ and $V_{IC} > 0.5\text{ V}$.

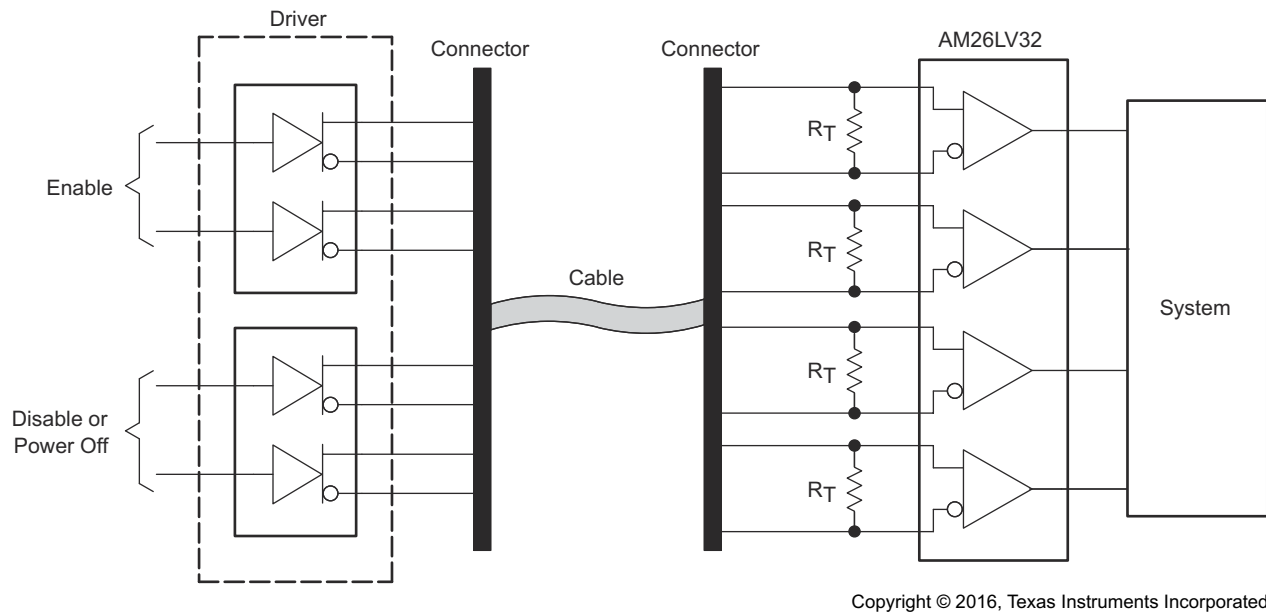
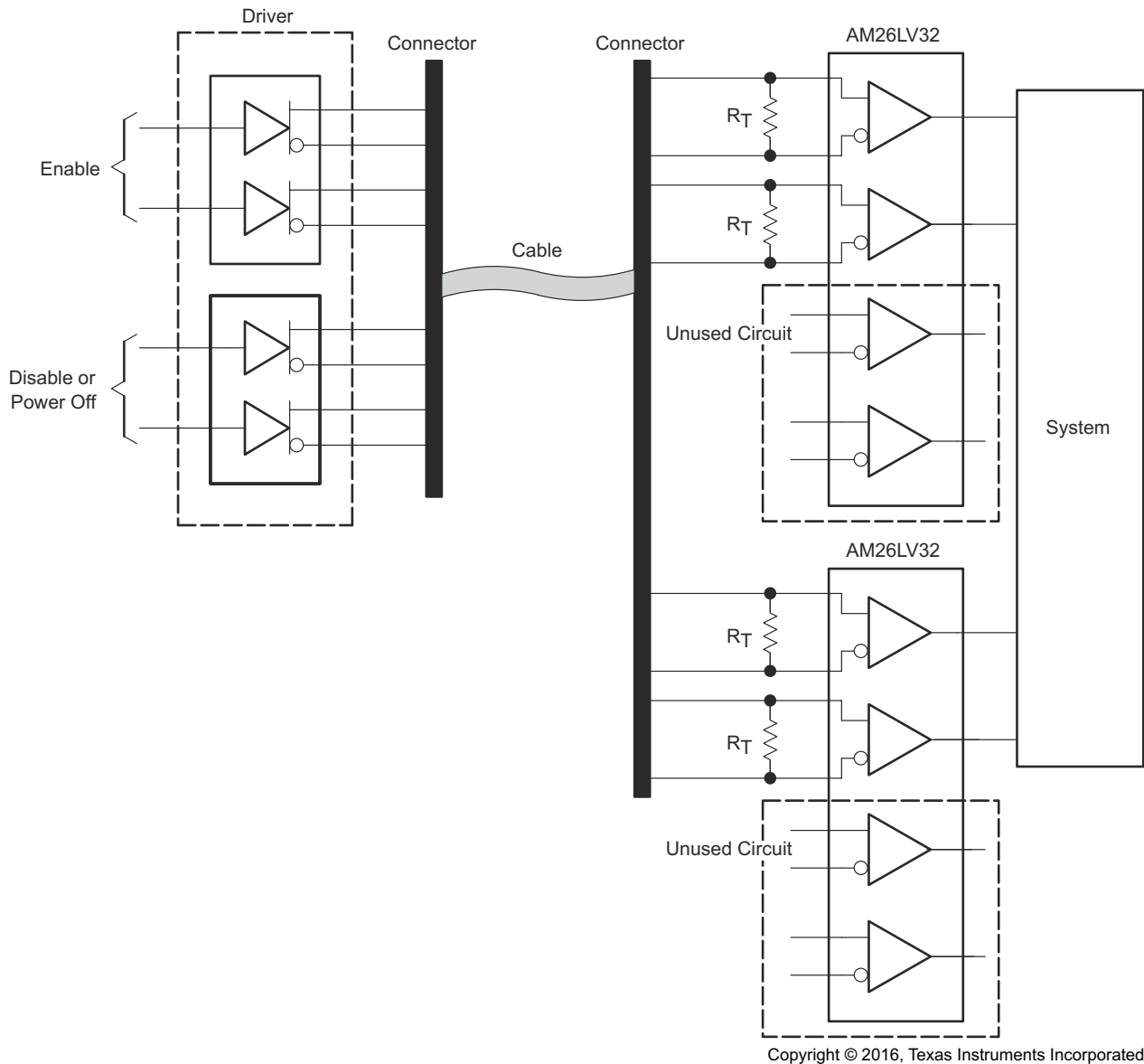

Figure 8-9. Typical Application Where Two or More Drivers Are Disabled

Figure 8-10 is an alternative application design to replace the application in Figure 8-9. This design uses two AM26LV32 devices instead of one. However, this design does not require the input levels be monitored to ensure the outputs are in the correct state, only that they comply to the RS-232 standard.



Copyright © 2016, Texas Instruments Incorporated

Figure 8-10. Alternative Solution for Figure 8-9

Figure 8-11 and Figure 8-12 show typical applications where a disconnected cable occurs. Figure 8-11 illustrates a typical application where a cable is disconnected. Similar to Figure 8-9, the active input levels must be monitored to make sure the inactive receiver outputs are in a high state. An alternative solution is shown in Figure 8-12.

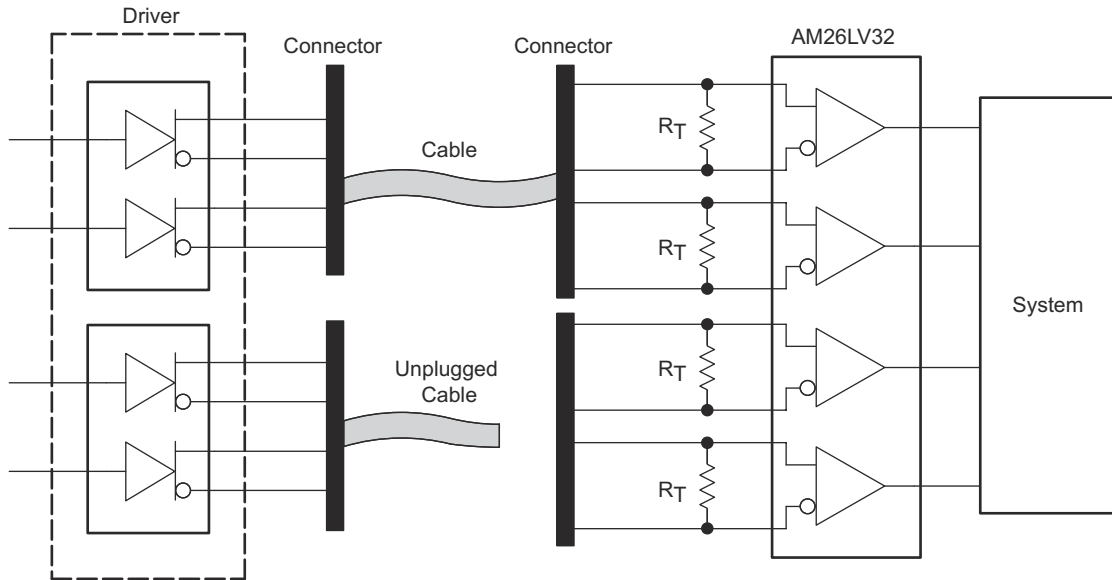

Copyright © 2016, Texas Instruments Incorporated

Figure 8-11. Typical Application Where Two or More Drivers Are Disconnected

Figure 8-12 is an alternative solution so the receiver inputs do not have to be monitored. This solution also requires the use of two AM26LV32 devices instead of one.

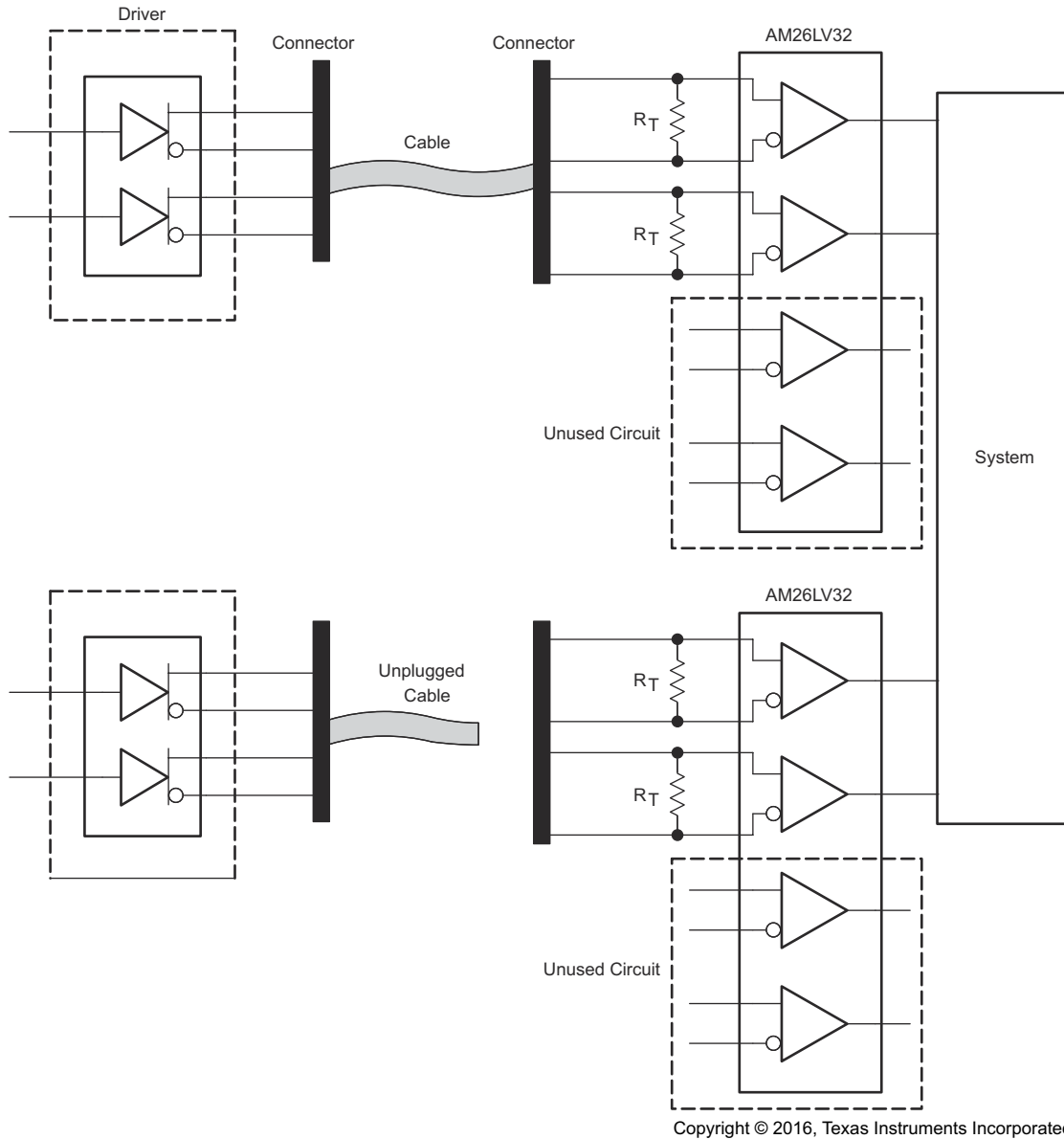

Copyright © 2016, Texas Instruments Incorporated

Figure 8-12. Alternative Solution to [Figure 8-11](#)

When designing a system using the AM26LV32, the device provides a robust solution where fail-safe and fault conditions are of concern. The RS422-like inputs accept common-mode input levels from -0.3 V to 5.5 V with a specified sensitivity of $\pm 200\text{ mV}$. As previously shown, take care with active input levels because this can affect the outputs of unused or inactive bits. However, most applications meet or exceed the requirements to allow the device to perform properly.

9 Application and Implementation

Note

Information in the following applications sections is not part of the TI component specification, and TI does not warrant its accuracy or completeness. TI's customers are responsible for determining suitability of components for their purposes, as well as validating and testing their design implementation to confirm system functionality.

9.1 Application Information

When designing a system that uses drivers, receivers, and transceivers that comply with RS422 or RS485, proper cable termination is essential for highly reliable applications with reduced reflections in the transmission line. Because RS422 allows only one driver on the bus, if termination is used, it is placed only at the end of the cable near the last receiver. In general, RS485 requires termination at both ends of the cable. Factors to consider when determining the type of termination usually are performance requirements of the application and the ever-present factor, cost. The different types of termination techniques include unterminated lines, parallel termination, ac termination, and multipoint termination.

9.2 Typical Application

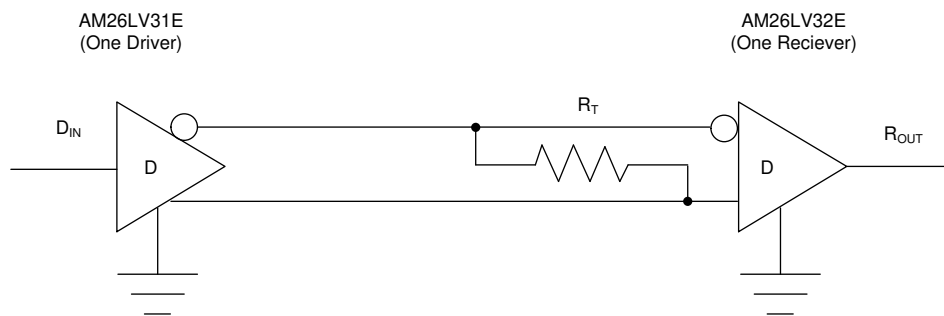

Copyright © 2016, Texas Instruments Incorporated

Figure 9-1. Differential Terminated Configuration

9.2.1 Design Requirements

Resistor and capacitor (if used) termination values vary from system to system. The termination resistor, R_T , must be within 20% of the characteristic impedance, R_{OUT} , of the cable and can vary from about 80 Ω to 120 Ω .

9.2.2 Detailed Design Procedure

Figure 9-1 shows a configuration with R_T as termination. Although reflections are present at the receiver inputs at a data signaling rate of 200 kbps with no termination, the RS422-compliant receiver reads only the input differential voltage and produces a clean signal at the output.

9.2.3 Application Curve

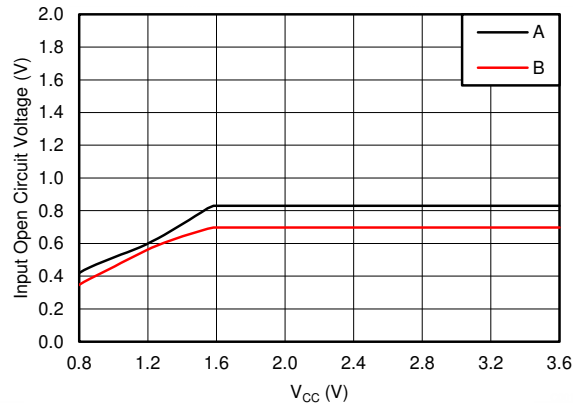

Figure 9-2. RS422 Port Open-Circuit Voltage vs V_{CC}

9.3 Power Supply Recommendations

Place 0.1- μ F bypass capacitors close to the power-supply pins to reduce errors coupling in from noisy or high-impedance power supplies.

9.4 Layout

9.4.1 Layout Guidelines

For best operational performance of the device, use good PCB layout practices including:

- Noise can propagate into analog circuitry through the power pins of the circuit as a whole, as well as the operational amplifier. Bypass capacitors are used to reduce the coupled noise by providing low impedance power sources local to the analog circuitry.
- Connect low-ESR, 0.1- μ F ceramic bypass capacitors between each supply pin and ground, placed as close to the device as possible. A single bypass capacitor from V+ to ground is applicable for single-supply applications.
- Separate grounding for analog and digital portions of circuitry is one of the simplest and most-effective methods of noise suppression. One or more layers on multilayer PCBs are usually devoted to ground planes. A ground plane helps distribute heat and reduces EMI noise pickup. Make sure to physically separate digital and analog grounds, and pay attention to the flow of the ground current.
- To reduce parasitic coupling, run the input traces as far away from the supply or output traces as possible. If it is not possible to keep them separate, it is much better to cross the sensitive trace perpendicular as opposed to in parallel with the noisy trace.
- Place the external components as close to the device as possible. Keeping RF and RG close to the inverting input minimizes parasitic capacitance.
- Keep the length of input traces as short as possible. Always remember that the input traces are the most sensitive part of the circuit.
- Consider a driven, low-impedance guard ring around the critical traces. A guard ring can significantly reduce leakage currents from nearby traces that are at different potentials.

9.4.2 Layout Example

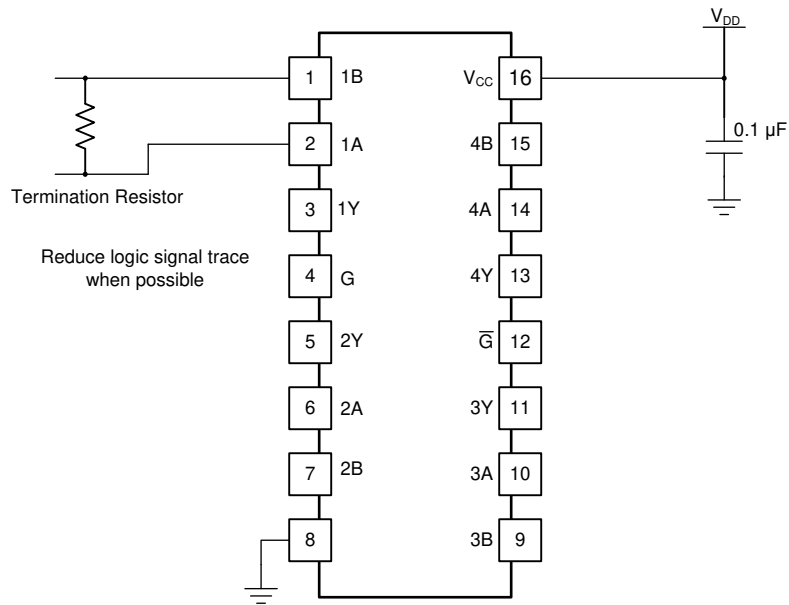

Figure 9-3. Layout With PCB Recommendations

10 Device and Documentation Support

10.1 Receiving Notification of Documentation Updates

To receive notification of documentation updates, navigate to the device product folder on ti.com. In the upper right corner, click on *Alert me* to register and receive a weekly digest of any product information that has changed. For change details, review the revision history included in any revised document.

10.2 Support Resources

[TI E2E™ support forums](#) are an engineer's go-to source for fast, verified answers and design help — straight from the experts. Search existing answers or ask your own question to get the quick design help you need.

Linked content is provided "AS IS" by the respective contributors. They do not constitute TI specifications and do not necessarily reflect TI's views; see TI's [Terms of Use](#).

10.3 Trademarks

TI E2E™ is a trademark of Texas Instruments.
All trademarks are the property of their respective owners.

10.4 Electrostatic Discharge Caution



This integrated circuit can be damaged by ESD. Texas Instruments recommends that all integrated circuits be handled with appropriate precautions. Failure to observe proper handling and installation procedures can cause damage.

ESD damage can range from subtle performance degradation to complete device failure. Precision integrated circuits may be more susceptible to damage because very small parametric changes could cause the device not to meet its published specifications.

10.5 Glossary

[TI Glossary](#) This glossary lists and explains terms, acronyms, and definitions.

11 Mechanical, Packaging, and Orderable Information

The following pages include mechanical, packaging, and orderable information. This information is the most current data available for the designated devices. This data is subject to change without notice and revision of this document. For browser-based versions of this data sheet, refer to the left-hand navigation.

PACKAGING INFORMATION

Orderable Device	Status (1)	Package Type	Package Drawing	Pins	Package Qty	Eco Plan (2)	Lead finish/ Ball material (6)	MSL Peak Temp (3)	Op Temp (°C)	Device Marking (4/5)	Samples
AM26LV32CD	LIFEBUY	SOIC	D	16	40	RoHS & Green	NIPDAU	Level-1-260C-UNLIM	0 to 70	AM26LV32C	
AM26LV32CDE4	LIFEBUY	SOIC	D	16	40	RoHS & Green	NIPDAU	Level-1-260C-UNLIM	0 to 70	AM26LV32C	
AM26LV32CDG4	LIFEBUY	SOIC	D	16	40	RoHS & Green	NIPDAU	Level-1-260C-UNLIM	0 to 70	AM26LV32C	
AM26LV32CDR	LIFEBUY	SOIC	D	16	2500	RoHS & Green	NIPDAU	Level-1-260C-UNLIM	0 to 70	AM26LV32C	
AM26LV32CDRE4	LIFEBUY	SOIC	D	16	2500	RoHS & Green	NIPDAU	Level-1-260C-UNLIM	0 to 70	AM26LV32C	
AM26LV32CDRG4	LIFEBUY	SOIC	D	16	2500	RoHS & Green	NIPDAU	Level-1-260C-UNLIM	0 to 70	AM26LV32C	
AM26LV32CNSR	LIFEBUY	SO	NS	16	2000	RoHS & Green	NIPDAU	Level-1-260C-UNLIM	0 to 70	26LV32	
AM26LV32CNSRG4	LIFEBUY	SO	NS	16	2000	RoHS & Green	NIPDAU	Level-1-260C-UNLIM	0 to 70	26LV32	
AM26LV32ID	LIFEBUY	SOIC	D	16	40	RoHS & Green	NIPDAU	Level-1-260C-UNLIM	-40 to 85	AM26LV32I	
AM26LV32IDE4	LIFEBUY	SOIC	D	16	40	RoHS & Green	NIPDAU	Level-1-260C-UNLIM	-40 to 85	AM26LV32I	
AM26LV32IDG4	LIFEBUY	SOIC	D	16	40	RoHS & Green	NIPDAU	Level-1-260C-UNLIM	-40 to 85	AM26LV32I	
AM26LV32IDR	ACTIVE	SOIC	D	16	2500	RoHS & Green	NIPDAU	Level-1-260C-UNLIM	-40 to 85	AM26LV32I	Samples
AM26LV32INS	LIFEBUY	SO	NS	16	50	RoHS & Green	NIPDAU	Level-1-260C-UNLIM	-40 to 85	26LV32I	
AM26LV32INSG4	LIFEBUY	SO	NS	16	50	RoHS & Green	NIPDAU	Level-1-260C-UNLIM	-40 to 85	26LV32I	
AM26LV32INSR	ACTIVE	SO	NS	16	2000	RoHS & Green	NIPDAU	Level-1-260C-UNLIM	-40 to 85	26LV32I	Samples

(1) The marketing status values are defined as follows:

ACTIVE: Product device recommended for new designs.

LIFEBUY: TI has announced that the device will be discontinued, and a lifetime-buy period is in effect.

NRND: Not recommended for new designs. Device is in production to support existing customers, but TI does not recommend using this part in a new design.

PREVIEW: Device has been announced but is not in production. Samples may or may not be available.

OBSELETE: TI has discontinued the production of the device.

(2) **RoHS:** TI defines "RoHS" to mean semiconductor products that are compliant with the current EU RoHS requirements for all 10 RoHS substances, including the requirement that RoHS substance do not exceed 0.1% by weight in homogeneous materials. Where designed to be soldered at high temperatures, "RoHS" products are suitable for use in specified lead-free processes. TI may reference these types of products as "Pb-Free".

RoHS Exempt: TI defines "RoHS Exempt" to mean products that contain lead but are compliant with EU RoHS pursuant to a specific EU RoHS exemption.

Green: TI defines "Green" to mean the content of Chlorine (Cl) and Bromine (Br) based flame retardants meet JS709B low halogen requirements of <=1000ppm threshold. Antimony trioxide based flame retardants must also meet the <=1000ppm threshold requirement.

(3) MSL, Peak Temp. - The Moisture Sensitivity Level rating according to the JEDEC industry standard classifications, and peak solder temperature.

(4) There may be additional marking, which relates to the logo, the lot trace code information, or the environmental category on the device.

(5) Multiple Device Markings will be inside parentheses. Only one Device Marking contained in parentheses and separated by a "~" will appear on a device. If a line is indented then it is a continuation of the previous line and the two combined represent the entire Device Marking for that device.

(6) Lead finish/Ball material - Orderable Devices may have multiple material finish options. Finish options are separated by a vertical ruled line. Lead finish/Ball material values may wrap to two lines if the finish value exceeds the maximum column width.

Important Information and Disclaimer:The information provided on this page represents TI's knowledge and belief as of the date that it is provided. TI bases its knowledge and belief on information provided by third parties, and makes no representation or warranty as to the accuracy of such information. Efforts are underway to better integrate information from third parties. TI has taken and continues to take reasonable steps to provide representative and accurate information but may not have conducted destructive testing or chemical analysis on incoming materials and chemicals. TI and TI suppliers consider certain information to be proprietary, and thus CAS numbers and other limited information may not be available for release.

In no event shall TI's liability arising out of such information exceed the total purchase price of the TI part(s) at issue in this document sold by TI to Customer on an annual basis.

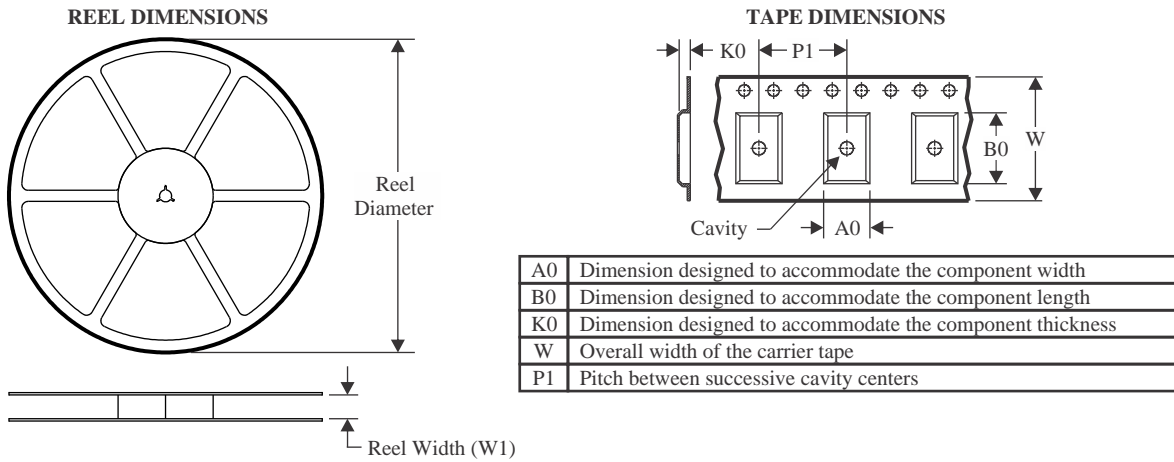
TAPE AND REEL INFORMATION

QUADRANT ASSIGNMENTS FOR PIN 1 ORIENTATION IN TAPE



*All dimensions are nominal

Device	Package Type	Package Drawing	Pins	SPQ	Reel Diameter (mm)	Reel Width W1 (mm)	A0 (mm)	B0 (mm)	K0 (mm)	P1 (mm)	W (mm)	Pin1 Quadrant
AM26LV32CDR	SOIC	D	16	2500	330.0	16.4	6.5	10.3	2.1	8.0	16.0	Q1
AM26LV32CDRG4	SOIC	D	16	2500	330.0	16.4	6.5	10.3	2.1	8.0	16.0	Q1
AM26LV32CDRG4	SOIC	D	16	2500	330.0	16.4	6.5	10.3	2.1	8.0	16.0	Q1
AM26LV32CNSR	SO	NS	16	2000	330.0	16.4	8.2	10.5	2.5	12.0	16.0	Q1
AM26LV32IDR	SOIC	D	16	2500	330.0	16.4	6.5	10.3	2.1	8.0	16.0	Q1
AM26LV32IDR	SOIC	D	16	2500	330.0	16.4	6.5	10.3	2.1	8.0	16.0	Q1
AM26LV32INSR	SO	NS	16	2000	330.0	16.4	8.2	10.5	2.5	12.0	16.0	Q1
AM26LV32INSR	SO	NS	16	2000	330.0	16.4	8.2	10.5	2.5	12.0	16.0	Q1

TAPE AND REEL BOX DIMENSIONS

*All dimensions are nominal

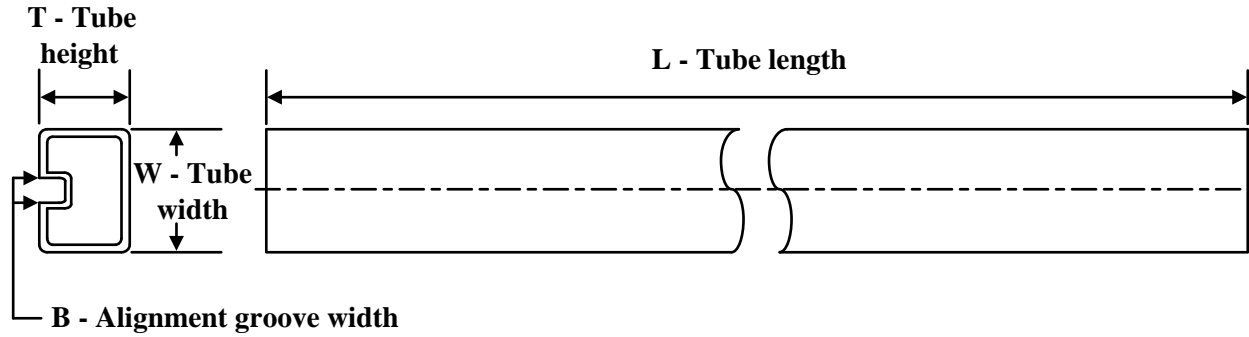
Device	Package Type	Package Drawing	Pins	SPQ	Length (mm)	Width (mm)	Height (mm)
AM26LV32CDR	SOIC	D	16	2500	340.5	336.1	32.0
AM26LV32CDRG4	SOIC	D	16	2500	356.0	356.0	35.0
AM26LV32CDRG4	SOIC	D	16	2500	340.5	336.1	32.0
AM26LV32CNSR	SO	NS	16	2000	356.0	356.0	35.0
AM26LV32IDR	SOIC	D	16	2500	353.0	353.0	32.0
AM26LV32IDR	SOIC	D	16	2500	340.5	336.1	32.0
AM26LV32INSR	SO	NS	16	2000	367.0	367.0	38.0
AM26LV32INSR	SO	NS	16	2000	353.0	353.0	32.0

TUBE

*All dimensions are nominal

Device	Package Name	Package Type	Pins	SPQ	L (mm)	W (mm)	T (μm)	B (mm)
AM26LV32CD	D	SOIC	16	40	506.6	8	3940	4.32
AM26LV32CD	D	SOIC	16	40	507	8	3940	4.32
AM26LV32CDE4	D	SOIC	16	40	507	8	3940	4.32
AM26LV32CDE4	D	SOIC	16	40	506.6	8	3940	4.32
AM26LV32CDG4	D	SOIC	16	40	506.6	8	3940	4.32
AM26LV32CDG4	D	SOIC	16	40	507	8	3940	4.32
AM26LV32ID	D	SOIC	16	40	507	8	3940	4.32
AM26LV32IDE4	D	SOIC	16	40	507	8	3940	4.32
AM26LV32IDG4	D	SOIC	16	40	507	8	3940	4.32
AM26LV32INS	NS	SOP	16	50	530	10.5	4000	4.1
AM26LV32INSG4	NS	SOP	16	50	530	10.5	4000	4.1



PACKAGE OUTLINE

NS0016A

SOP - 2.00 mm max height

SOP



4220735/A 12/2021

NOTES:

1. All linear dimensions are in millimeters. Dimensions in parenthesis are for reference only. Dimensioning and tolerancing per ASME Y14.5M.
2. This drawing is subject to change without notice.
3. This dimension does not include mold flash, protrusions, or gate burrs. Mold flash, protrusions, or gate burrs shall not exceed 0.15 mm, per side.
4. This dimension does not include interlead flash. Interlead flash shall not exceed 0.25 mm, per side.

EXAMPLE BOARD LAYOUT

NS0016A

SOP - 2.00 mm max height

SOP



4220735/A 12/2021

NOTES: (continued)

5. Publication IPC-7351 may have alternate designs.

6. Solder mask tolerances between and around signal pads can vary based on board fabrication site.

EXAMPLE STENCIL DESIGN

NS0016A

SOP - 2.00 mm max height

SOP



SOLDER PASTE EXAMPLE
BASED ON 0.125 mm THICK STENCIL
SCALE:7X

4220735/A 12/2021

NOTES: (continued)

7. Laser cutting apertures with trapezoidal walls and rounded corners may offer better paste release. IPC-7525 may have alternate design recommendations.
8. Board assembly site may have different recommendations for stencil design.

D (R-PDSO-G16)

PLASTIC SMALL OUTLINE



- NOTES:
- A. All linear dimensions are in inches (millimeters).
 - B. This drawing is subject to change without notice.
 - C. Body length does not include mold flash, protrusions, or gate burrs. Mold flash, protrusions, or gate burrs shall not exceed 0.006 (0,15) each side.
 - D. Body width does not include interlead flash. Interlead flash shall not exceed 0.017 (0,43) each side.
 - E. Reference JEDEC MS-012 variation AC.

MECHANICAL DATA

NS (R-PDSO-G**)

PLASTIC SMALL-OUTLINE PACKAGE

14-PINS SHOWN



- NOTES:
- A. All linear dimensions are in millimeters.
 - B. This drawing is subject to change without notice.
 - C. Body dimensions do not include mold flash or protrusion, not to exceed 0,15.

IMPORTANT NOTICE AND DISCLAIMER

TI PROVIDES TECHNICAL AND RELIABILITY DATA (INCLUDING DATA SHEETS), DESIGN RESOURCES (INCLUDING REFERENCE DESIGNS), APPLICATION OR OTHER DESIGN ADVICE, WEB TOOLS, SAFETY INFORMATION, AND OTHER RESOURCES "AS IS" AND WITH ALL FAULTS, AND DISCLAIMS ALL WARRANTIES, EXPRESS AND IMPLIED, INCLUDING WITHOUT LIMITATION ANY IMPLIED WARRANTIES OF MERCHANTABILITY, FITNESS FOR A PARTICULAR PURPOSE OR NON-INFRINGEMENT OF THIRD PARTY INTELLECTUAL PROPERTY RIGHTS.

These resources are intended for skilled developers designing with TI products. You are solely responsible for (1) selecting the appropriate TI products for your application, (2) designing, validating and testing your application, and (3) ensuring your application meets applicable standards, and any other safety, security, regulatory or other requirements.

These resources are subject to change without notice. TI grants you permission to use these resources only for development of an application that uses the TI products described in the resource. Other reproduction and display of these resources is prohibited. No license is granted to any other TI intellectual property right or to any third party intellectual property right. TI disclaims responsibility for, and you will fully indemnify TI and its representatives against, any claims, damages, costs, losses, and liabilities arising out of your use of these resources.

TI's products are provided subject to [TI's Terms of Sale](#) or other applicable terms available either on [ti.com](https://www.ti.com) or provided in conjunction with such TI products. TI's provision of these resources does not expand or otherwise alter TI's applicable warranties or warranty disclaimers for TI products.

TI objects to and rejects any additional or different terms you may have proposed.

Mailing Address: Texas Instruments, Post Office Box 655303, Dallas, Texas 75265
Copyright © 2024, Texas Instruments Incorporated

Looking for pricing, stock, or lifecycle information?

Click below to explore more details on WIN SOURCE:

 [View AM26LV32CDRG4](#) on WIN SOURCE

 [Texas Instruments](#) Information

Optimize Your Supply Chain with WIN SOURCE Solutions

-  Global Sourcing Solution
-  Obsolete Management
-  Cost Control Management
-  Shortage Management
-  Alternative Solution
-  Excess Inventory Management