



**THE DATASHEET OF**  
**8538BG-31LFT**



### General Description

The 8538-31 is a low skew, high performance 1-to-8 Crystal Oscillator/LVCMOS-to-3.3V LVPECL Fanout Buffer. The 8538-31 has selectable single ended clock or crystal inputs. The single ended clock input accepts LVCMOS or LVTTTL input levels and translate them to 3.3V LVPECL levels. The output enable is internally synchronized to eliminate runt pulses on the outputs during asynchronous assertion/deassertion of the clock enable pin.

Guaranteed output and part-to-part skew characteristics make the 8538-31 ideal for those applications demanding well defined performance and repeatability.

### Features

- Eight differential 3.3V LVPECL outputs
- Selectable LVCMOS/LVTTTL clock or crystal inputs
- CLK can accept the following input levels: LVCMOS, LVTTTL
- Maximum output frequency: 266MHz
- Crystal frequency range: 14MHz - 40MHz
- Output skew: 50ps (maximum)
- Part-to-part skew: 250ps (maximum)
- Propagation delay: 2.2ns (maximum)
- 3.3V operating supply mode
- 0°C to 70°C ambient operating temperature
- Industrial temperature information available upon request
- Available in lead-free (RoHS 6) package

### Block Diagram

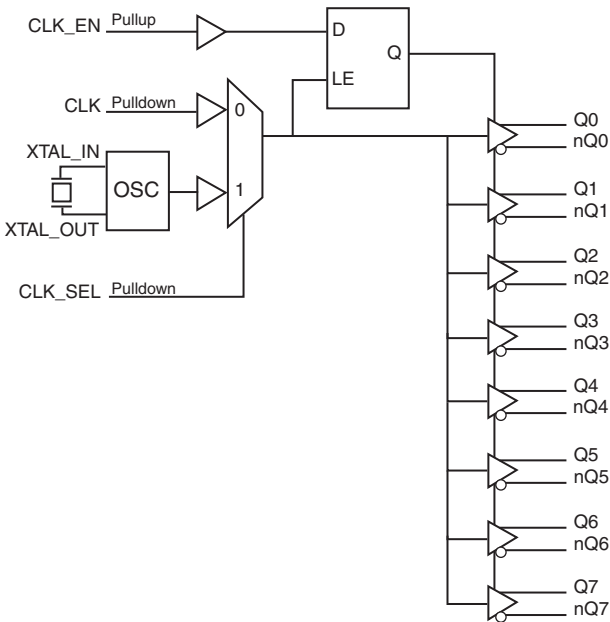

### Pin Assignment

CLK	1	28	Vcc
CLK_SEL	2	27	XTAL_IN
CLK_EN	3	26	XTAL_OUT
VEE	4	25	VEE
nQ7	5	24	Q0
Q7	6	23	nQ0
Vcco	7	22	Vcco
nQ6	8	21	Q1
Q6	9	20	nQ1
nQ5	10	19	Q2
Q5	11	18	nQ2
VEE	12	17	Vcco
nQ4	13	16	Q3
Q4	14	15	nQ3

**28-Lead TSSOP, 173MIL**  
**4.4mm x 9.7mm x 0.925mm package body**  
**G Package**  
**Top View**

**Table 1. Pin Descriptions**

Number	Name	Type		Description
1	CLK	Input	Pulldown	Single-ended clock input. LVCMOS/LVTTL interface levels.
2	CLK_SEL	Input	Pulldown	
3	CLK_EN	Input	Pullup	
4, 12, 25	V <sub>EE</sub>	Power		Negative supply pins.
5, 6	nQ7, Q7	Output		Differential output pair. LVPECL interface levels.
7, 17, 22	V <sub>CC0</sub>	Power		Output supply pins.
8, 9	nQ6, Q6	Output		Differential output pair. LVPECL interface levels.
10, 11	nQ5, Q5	Output		Differential output pair. LVPECL interface levels.
13, 14	nQ4, Q4	Output		Differential output pair. LVPECL interface levels.
15, 16	nQ3, Q3	Output		Differential output pair. LVPECL interface levels.
18, 19	nQ2, Q2	Output		Differential output pair. LVPECL interface levels.
20, 21	nQ1, Q1	Output		Differential output pair. LVPECL interface levels.
23, 24	nQ0, Q0	Output		Differential output pair. LVPECL interface levels.
26, 27	XTAL_OUT XTAL_IN	Input		Crystal oscillator interface. XTAL_IN is the input, XTAL_OUT is the output.
28	V <sub>CC</sub>	Power		Positive supply pin.

NOTE: Pullup and Pulldown refer to internal input resistors. See Table 2, Pin Characteristics, for typical values.

**Table 2. Pin Characteristics**

Symbol	Parameter	Test Conditions	Minimum	Typical	Maximum	Units
C <sub>IN</sub>	Input Capacitance			4		pF
R <sub>PULLUP</sub>	Input Pullup Resistor			51		kΩ
R <sub>PULLDOWN</sub>	Input Pulldown Resistor			51		kΩ

## Function Tables

**Table 3A. Control Input Function Table**

Inputs			Outputs	
CLK_EN	CLK_SEL	Selected Source	Q0:Q7	nQ0:nQ7
0	0	CLK	Disabled; Low	Disabled; High
0	1	XTAL_IN, XTAL_OUT	Disabled; Low	Disabled; High
1	0	CLK	Enabled	Enabled
1	1	XTAL_IN, XTAL_OUT	Enabled	Enabled

After CLK\_EN switches, the clock outputs are disabled or enabled following a rising and falling input clock or crystal oscillator edge as shown in Figure 1. In the active mode, the state of the outputs are a function of the CLK input as described in Table 3B.

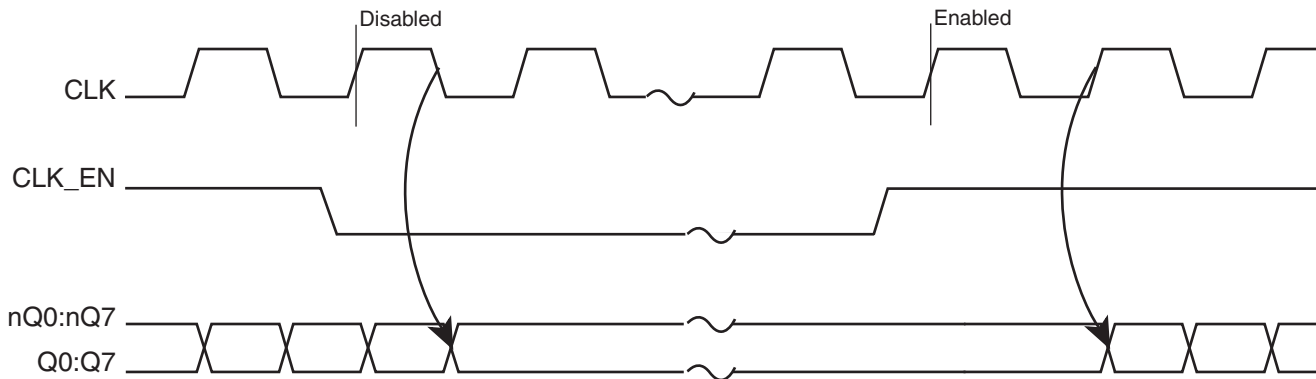

**Figure 1. CLK\_EN Timing Diagram**

**Table 3B. Clock Input Function Table**

Inputs	Outputs	
CLK	Q0:Q7	nQ0:nQ7
0	LOW	HIGH
1	HIGH	LOW

## Absolute Maximum Ratings

NOTE: Stresses beyond those listed under *Absolute Maximum Ratings* may cause permanent damage to the device. These ratings are stress specifications only. Functional operation of product at these conditions or any conditions beyond those listed in the *DC Characteristics* or *AC Characteristics* is not implied. Exposure to absolute maximum rating conditions for extended periods may affect product reliability.

Item	Rating
Supply Voltage, $V_{CC}$	4.6V
Inputs, $V_I$	-0.5V to $V_{CC} + 0.5V$
Outputs, $I_O$ Continuous Current Surge Current	50mA 100mA
Package Thermal Impedance, $\theta_{JA}$	49.8°C/W (0 lfpn)
Storage Temperature, $T_{STG}$	-65°C to 150°C

## DC Electrical Characteristics

**Table 4A. Power Supply DC Characteristics,  $V_{CC} = V_{CCO} = 3.3V \pm 5\%$ ,  $V_{EE} = 0V$ ,  $T_A = 0^\circ C$  to  $70^\circ C$**

Symbol	Parameter	Test Conditions	Minimum	Typical	Maximum	Units
$V_{CC}$	Positive Supply Voltage		3.135	3.3	3.465	V
$V_{CCO}$	Output Supply Voltage		3.135	3.3	3.465	V
$I_{EE}$	Power Supply Current				110	mA
$I_{CCO}$	Output Supply Current				50	mA

**Table 4B. LVCMOS/LVTTL DC Characteristics,  $V_{CC} = V_{CCO} = 3.3V \pm 5\%$ ,  $V_{EE} = 0V$ ,  $T_A = 0^\circ C$  to  $70^\circ C$**

Symbol	Parameter	Test Conditions	Minimum	Typical	Maximum	Units
$V_{IH}$	Input High Voltage		2		$V_{CC} + 0.3$	V
$V_{IL}$	Input Low Voltage		-0.3		0.8	V
$I_{IH}$	Input High Current	CLK, CLK_SEL	$V_{CC} = V_{IN} = 3.465V$		150	$\mu A$
		CLK_EN	$V_{CC} = V_{IN} = 3.465V$		5	$\mu A$
$I_{IL}$	Input Low Current	CLK, CLK_SEL	$V_{CC} = 3.465V, V_{IN} = 0V$	-5		$\mu A$
		CLK_EN	$V_{CC} = 3.465V, V_{IN} = 0V$	-150		$\mu A$

**Table 4C. LVPECL DC Characteristics,  $V_{CC} = V_{CCO} = 3.3V \pm 5\%$ ,  $V_{EE} = 0V$ ,  $T_A = 0^\circ C$  to  $70^\circ C$**

Symbol	Parameter	Test Conditions	Minimum	Typical	Maximum	Units
$V_{OH}$	Output High Current; NOTE 1		$V_{CCO} - 1.4$		$V_{CCO} - 0.9$	$\mu A$
$V_{OL}$	Output Low Current; NOTE 1		$V_{CCO} - 2.0$		$V_{CCO} - 1.7$	$\mu A$
$V_{SWING}$	Peak-to-Peak Output Voltage Swing		0.6		1.0	V

NOTE 1: Outputs terminated with  $50\Omega$  to  $V_{CCO} - 2V$ .

**Table 5. Crystal Characteristics**

Parameter	Test Conditions	Minimum	Typical	Maximum	Units
Mode of Oscillation		Fundamental			
Frequency		14		40	MHz
Equivalent Series Resistance (ESR)				50	$\Omega$
Shunt Capacitance				7	pF
Drive Level				1	mW

## AC Electrical Characteristics

**Table 6. AC Characteristics,  $V_{CC} = V_{CCO} = 3.3V \pm 5\%$ ,  $V_{EE} = 0V$ ,  $T_A = 0^\circ C$  to  $70^\circ C$** 

Parameter	Symbol	Test Conditions	Minimum	Typical	Maximum	Units
$f_{MAX}$	Output Frequency				266	MHz
$t_{PD}$	Propagation Delay; NOTE 1				2.2	ns
$t_{sk(o)}$	Output Skew; NOTE 2, 4				50	ps
$t_{sk(pp)}$	Part-to-Part Skew; NOTE 3, 4				250	ps
$t_R / t_F$	Output Rise/Fall Time	20% to 80%	200		700	ps
odc	Output Duty Cycle		45		55	%

All parameters measured at  $f_{MAX}$  unless noted otherwise.

NOTE 1: Measured from  $V_{CC}/2$  input crossing point to the differential output crossing point.

NOTE 2: Defined as skew between outputs at the same supply voltage and with equal load conditions. Measured at the output differential cross points.

NOTE 3: Defined as skew between outputs on different devices operating at the same supply voltages and with equal load conditions. Using the same type of inputs on each device, the outputs are measured at the differential cross points.

NOTE 4: This parameter is defined in accordance with JEDEC Standard 65.

### Parameter Measurement Information

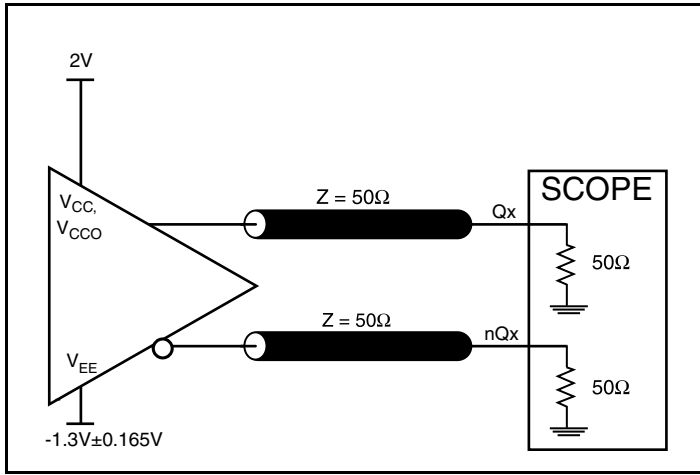

3.3/3.3V LVPECL Output Load AC Test Circuit

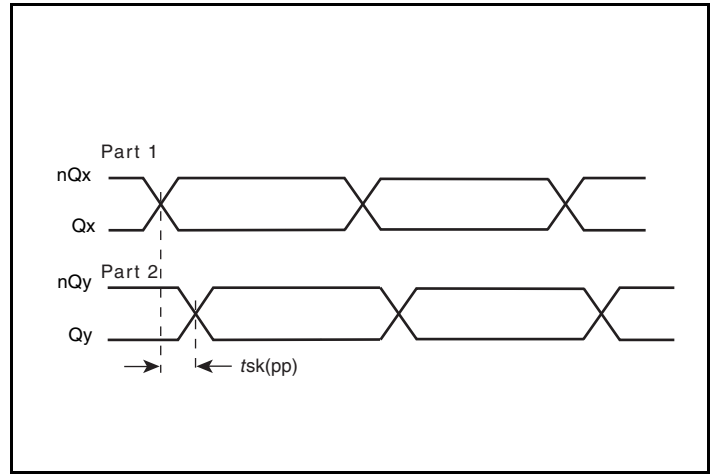

Part-to-Part Skew

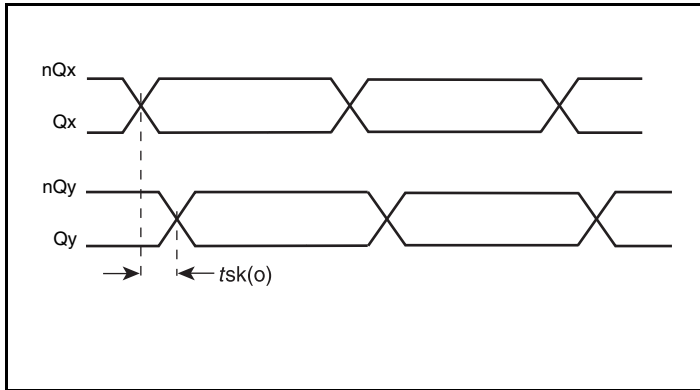

Output Skew

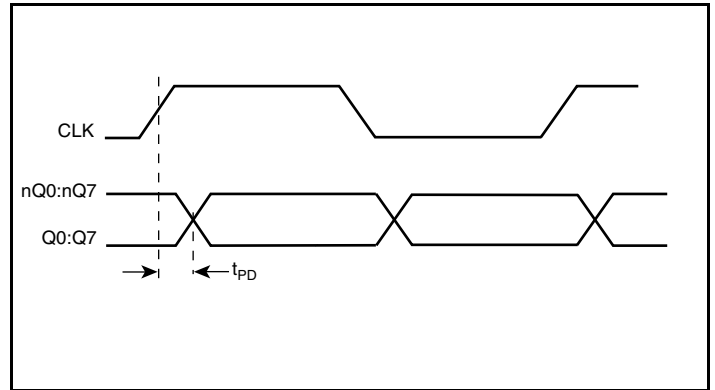

Propagation Delay

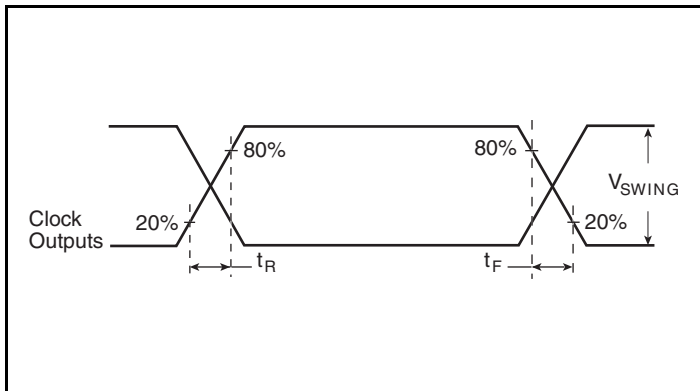

Output Rise/Fall Time

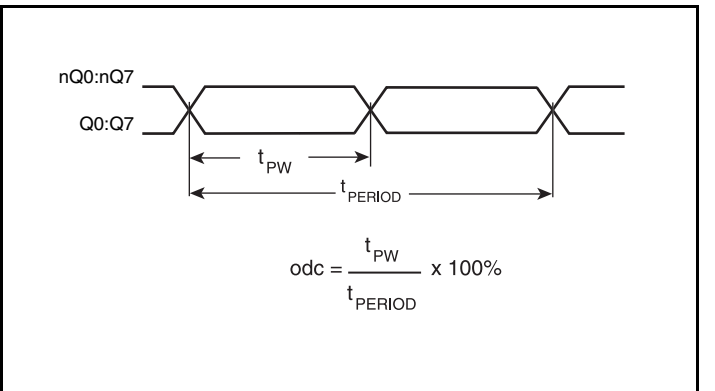

Output Duty Cycle/Pulse Width/Period

### Application Information

## Crystal Input Interface

The 8538-31 has been characterized with 18pF parallel resonant crystals. The capacitor values, C1 and C2, shown in *Figure 2* below were determined using an 18pF parallel resonant crystal and were chosen to minimize the ppm error. These same capacitor values will

tune any 18pF parallel resonant crystal over the frequency range and other parameters specified in this data sheet. The optimum C1 and C2 values can be slightly adjusted for different board layouts.

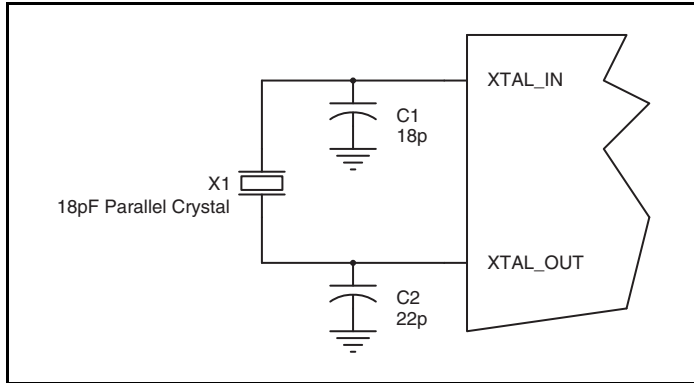
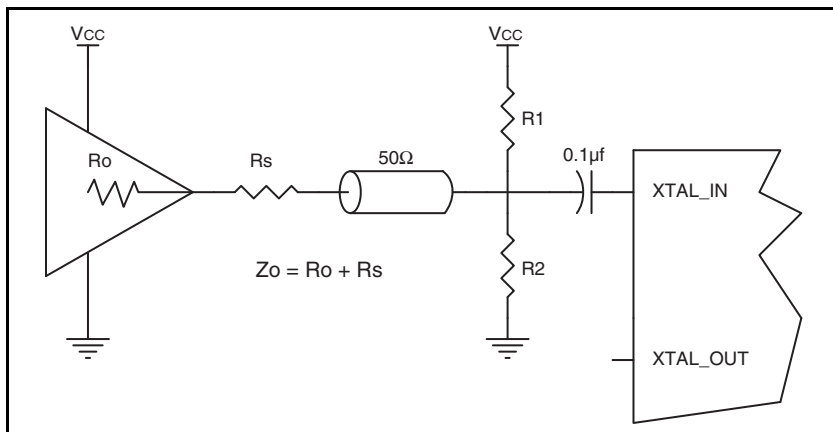

**Figure 2. Crystal Input Interface**

## LVC MOS to XTAL Interface

The XTAL\_IN input can accept a single-ended LVC MOS signal through an AC coupling capacitor. A general interface diagram is shown in *Figure 3*. The XTAL\_OUT pin can be left floating. The input edge rate can be as slow as 10ns. For LVC MOS inputs, it is recommended that the amplitude be reduced from full swing to half swing in order to prevent signal interference with the power rail and to reduce noise. This configuration requires that the output

impedance of the driver ( $R_o$ ) plus the series resistance ( $R_s$ ) equals the transmission line impedance. In addition, matched termination at the crystal input will attenuate the signal in half. This can be done in one of two ways. First, R1 and R2 in parallel should equal the transmission line impedance. For most 50Ω applications, R1 and R2 can be 100Ω. This can also be accomplished by removing R1 and making R2 50Ω.



**Figure 3. General Diagram for LVC MOS Driver to XTAL Input Interface**

## Recommendations for Unused Input and Output Pins

### Inputs:

#### Crystal Inputs

For applications not requiring the use of the crystal oscillator input, both XTAL\_IN and XTAL\_OUT can be left floating. Though not required, but for additional protection, a 1kΩ resistor can be tied from XTAL\_IN to ground.

#### CLK Input

For applications not requiring the use of a clock input, it can be left floating. Though not required, but for additional protection, a 1kΩ resistor can be tied from the CLK input to ground.

#### LVC MOS Control Pins

All control pins have internal pull-ups or pull-downs; additional resistance is not required but can be added for additional protection. A 1kΩ resistor can be used.

### Outputs:

#### LVPECL Outputs

All unused LVPECL outputs can be left floating. We recommend that there is no trace attached. Both sides of the differential output pair should either be left floating or terminated.

## Termination for 3.3V LVPECL Outputs

The clock layout topology shown below is a typical termination for LVPECL outputs. The two different layouts mentioned are recommended only as guidelines.

FOUT and nFOUT are low impedance follower outputs that generate ECL/LVPECL compatible outputs. Therefore, terminating resistors (DC current path to ground) or current sources must be used for functionality. These outputs are designed to drive 50Ω transmission

lines. Matched impedance techniques should be used to maximize operating frequency and minimize signal distortion. *Figures 4A and 4B* show two different layouts which are recommended only as guidelines. Other suitable clock layouts may exist and it would be recommended that the board designers simulate to guarantee compatibility across all printed circuit and clock component process variations.

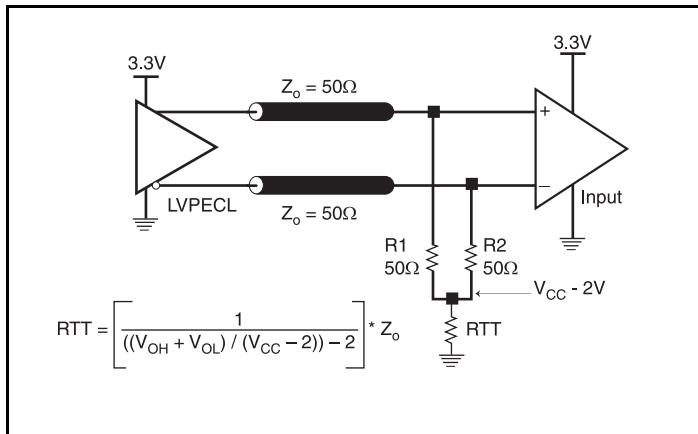

Figure 4A. 3.3V LVPECL Output Termination

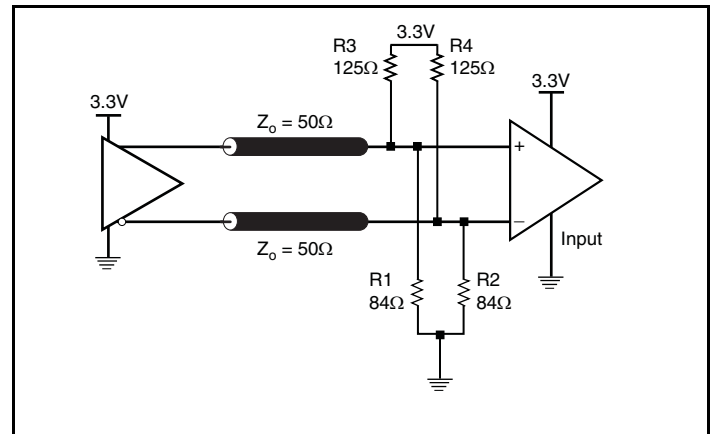

Figure 4B. 3.3V LVPECL Output Termination

## Power Considerations

This section provides information on power dissipation and junction temperature for the 8538-31. Equations and example calculations are also provided.

### 1. Power Dissipation.

The total power dissipation for the 8538-31 is the sum of the core power plus the power dissipated in the load(s). The following is the power dissipation for  $V_{CC} = 3.3V + 5\% = 3.465V$ , which gives worst case results.

NOTE: Please refer to Section 3 for details on calculating power dissipated in the load.

- Power (core)<sub>MAX</sub> =  $V_{CC\_MAX} * I_{EE\_MAX} = 3.465V * 110mA = \mathbf{381.15mW}$
- Power (outputs)<sub>MAX</sub> = **30mW/Loaded Output pair**  
If all outputs are loaded, the total power is  $8 * 30mW = \mathbf{240mW}$

**Total Power<sub>MAX</sub>** (3.3V, with all outputs switching) =  $381.15mW + 240mW = \mathbf{621.15mW}$

### 2. Junction Temperature.

Junction temperature,  $T_j$ , is the temperature at the junction of the bond wire and bond pad and directly affects the reliability of the device. The maximum recommended junction temperature for HiPerClockS devices is 125°C.

The equation for  $T_j$  is as follows:  $T_j = \theta_{JA} * Pd\_total + T_A$

$T_j$  = Junction Temperature

$\theta_{JA}$  = Junction-to-Ambient Thermal Resistance

$Pd\_total$  = Total Device Power Dissipation (example calculation is in section 1 above)

$T_A$  = Ambient Temperature

In order to calculate junction temperature, the appropriate junction-to-ambient thermal resistance  $\theta_{JA}$  must be used. Assuming no air flow and a multi-layer board, the appropriate value is 49.8°C/W per Table 7 below.

Therefore,  $T_j$  for an ambient temperature of 70°C with all outputs switching is:

$$70^\circ\text{C} + 0.621\text{W} * 49.8^\circ\text{C/W} = 100.9^\circ\text{C}. \text{ This is well below the limit of } 125^\circ\text{C}.$$

This calculation is only an example.  $T_j$  will obviously vary depending on the number of loaded outputs, supply voltage, air flow and the type of board (single layer or multi-layer).

**Table 7. Thermal Resistance  $\theta_{JA}$  for 28 Lead TSSOP, Forced Convection**

Linear Feet per Minute	$\theta_{JA}$ by Velocity		
	0	200	500
Single-Layer PCB, JEDEC Standard Test Boards	82.9°C/W	68.7°C/W	60.5°C/W
Multi-Layer PCB, JEDEC Standard Test Boards	49.8°C/W	43.9°C/W	41.2°C/W

NOTE: Most modern PCB design use multi-layered boards. The data in the second row pertains to most designs.

### 3. Calculations and Equations.

The purpose of this section is to derive the power dissipated into the load.

LVPECL output driver circuit and termination are shown in *Figure 5*.

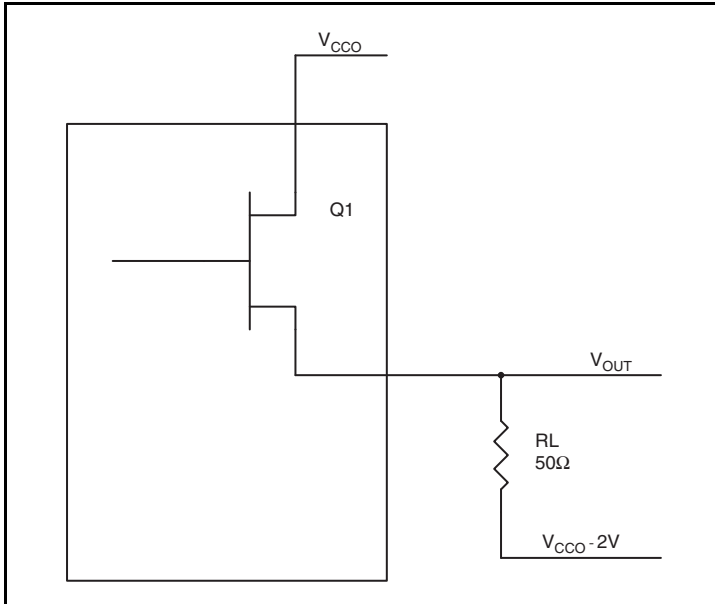

**Figure 5. LVPECL Driver Circuit and Termination**

To calculate worst case power dissipation into the load, use the following equations which assume a  $50\Omega$  load, and a termination voltage of  $V_{CCO} - 2V$ .

- For logic high,  $V_{OUT} = V_{OH\_MAX} = V_{CCO\_MAX} - 0.9V$   
 $(V_{CCO\_MAX} - V_{OH\_MAX}) = 0.9V$
- For logic low,  $V_{OUT} = V_{OL\_MAX} = V_{CCO\_MAX} - 1.7V$   
 $(V_{CCO\_MAX} - V_{OL\_MAX}) = 1.7V$

$Pd\_H$  is power dissipation when the output drives high.

$Pd\_L$  is the power dissipation when the output drives low.

$$Pd\_H = [(V_{OH\_MAX} - (V_{CCO\_MAX} - 2V))/R_L] * (V_{CCO\_MAX} - V_{OH\_MAX}) = [(2V - (V_{CCO\_MAX} - V_{OH\_MAX}))/R_L] * (V_{CCO\_MAX} - V_{OH\_MAX}) = [(2V - 0.9V)/50\Omega] * 0.9V = \mathbf{19.8mW}$$

$$Pd\_L = [(V_{OL\_MAX} - (V_{CCO\_MAX} - 2V))/R_L] * (V_{CCO\_MAX} - V_{OL\_MAX}) = [(2V - (V_{CCO\_MAX} - V_{OL\_MAX}))/R_L] * (V_{CCO\_MAX} - V_{OL\_MAX}) = [(2V - 1.7V)/50\Omega] * 1.7V = \mathbf{10.2mW}$$

$$\text{Total Power Dissipation per output pair} = Pd\_H + Pd\_L = \mathbf{30mW}$$

## Reliability Information

**Table 8.  $\theta_{JA}$  vs. Air Flow Table for a 282 Lead TSSOP**

$\theta_{JA}$ by Velocity			
Linear Feet per Minute	0	200	500
Single-Layer PCB, JEDEC Standard Test Boards	82.9°C/W	68.7°C/W	60.5°C/W
Multi-Layer PCB, JEDEC Standard Test Boards	49.8°C/W	43.9°C/W	41.2°C/W

NOTE: Most modern PCB design use multi-layered boards. The data in the second row pertains to most designs.

## Transistor Count

The transistor count for ICS8430-62 is: 4258

## Package Outline and Package Dimension

**Package Outline - G Suffix for 28 Lead TSSOP**

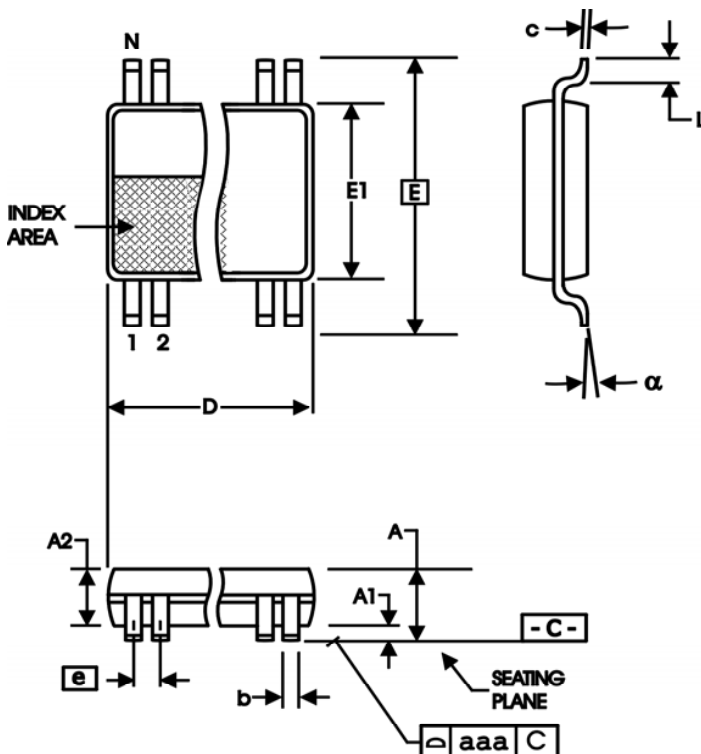

All Dimensions in Millimeters		
Symbol	Minimum	Maximum
b	0.19	0.30
c	0.09	0.20
D	9.60	9.80
E	6.40 Basic	
E1	4.30	4.50
e	0.65 Basic	
L	0.45	0.75
$\alpha$	0°	8°
aaa		0.10

Reference Document: JEDEC Publication 95, MO-153

**Table 9. Package Dimensions**

All Dimensions in Millimeters		
Symbol	Minimum	Maximum
N	28	
A		1.20
A1	0.5	0.15
A2	0.80	1.05

## Ordering Information

Table 10. Ordering Information

Part/Order Number	Marking	Package	Shipping Packaging	Temperature
ICS8538BG-31LF	ICS8538BG-31LF	"Lead-Free" 28 Lead TSSOP	Tube	0°C to 70°C
ICS8538BG-31LFT	ICS8538BG-31LF	"Lead-Free" 28 Lead TSSOP	Tape & Reel	0°C to 70°C

NOTE: Parts that are ordered with an "LF" suffix to the part number are the Pb-Free configuration and are RoHS compliant.

## Revision History Sheet

Rev	Table	Page	Description of Change	Date
A	T10	13	Ordering Information table - added Lead-Free marking.	1/18/08
B	T6	5 9	AC Characteristics Table - changed Output Rise/Fall parameters from 500ps min. to 200ps min., and 850ps max. to 700ps max. Power Considerations - updated Junction Temperature equation with worst case thermal resistance of 0 lfm at 49.8°C/W.	2/5/08
B	T10	12	Ordering Information - removed leaded devices. Updated data sheet format.	7/10/15



**Corporate Headquarters**  
6024 Silver Creek Valley Road  
San Jose, CA 95138 USA

**Sales**  
1-800-345-7015 or 408-284-8200  
Fax: 408-284-2775  
www.IDT.com

**Tech Support**  
email: [clocks@idt.com](mailto:clocks@idt.com)

DISCLAIMER Integrated Device Technology, Inc. (IDT) and its subsidiaries reserve the right to modify the products and/or specifications described herein at any time and at IDT's sole discretion. All information in this document, including descriptions of product features and performance, is subject to change without notice. Performance specifications and the operating parameters of the described products are determined in the independent state and are not guaranteed to perform the same way when installed in customer products. The information contained herein is provided without representation or warranty of any kind, whether express or implied, including, but not limited to, the suitability of IDT's products for any particular purpose, an implied warranty of merchantability, or non-infringement of the intellectual property rights of others. This document is presented only as a guide and does not convey any license under intellectual property rights of IDT or any third parties.

IDT's products are not intended for use in applications involving extreme environmental conditions or in life support systems or similar devices where the failure or malfunction of an IDT product can be reasonably expected to significantly affect the health or safety of users. Anyone using an IDT product in such a manner does so at their own risk, absent an express, written agreement by IDT.

While the information presented herein has been checked for both accuracy and reliability, Integrated Device Technology (IDT) assumes no responsibility for either its use or for the infringement of any patents or other rights of third parties, which would result from its use. No other circuits, patents, or licenses are implied. This product is intended for use in normal commercial applications. Any other applications, such as those requiring extended temperature ranges, high reliability or other extraordinary environmental requirements are not recommended without additional processing by IDT. IDT reserves the right to change any circuitry or specifications without notice. IDT does not authorize or warrant any IDT product for use in life support devices or critical medical instruments.

Integrated Device Technology, IDT and the IDT logo are registered trademarks of IDT. Product specification subject to change without notice. Other trademarks and service marks used herein, including protected names, logos and designs, are the property of IDT or their respective third party owners.

Copyright ©2015 Integrated Device Technology, Inc.. All rights reserved.

## Looking for pricing, stock, or lifecycle information?

Click below to explore more details on WIN SOURCE:

-  [View 8538BG-31LFT on WIN SOURCE](#)
-  [IDT, Integrated Device Technology Inc Information](#)

## Optimize Your Supply Chain with WIN SOURCE Solutions

-  Global Sourcing Solution
-  Obsolete Management
-  Cost Control Management
-  Shortage Management
-  Alternative Solution
-  Excess Inventory Management