



**THE DATASHEET OF
LT1001ACN8#PBF**



FEATURES

- **Guaranteed Low Offset Voltage**

LT1001AM	15 μ V max
LT1001C	60 μ V max
- **Guaranteed Low Drift**

LT1001AM	0.6 μ V/ $^{\circ}$ C max
LT1001C	1.0 μ V/ $^{\circ}$ C max
- **Guaranteed Low Bias Current**

LT1001AM	2nA max
LT1001C	4nA max
- **Guaranteed CMRR**

LT1001AM	114dB min
LT1001C	110dB min
- **Guaranteed PSRR**

LT1001AM	110dB min
LT1001C	106dB min
- **Low Power Dissipation**

LT1001AM	75mW max
LT1001C	80mW max
- **Low Noise 0.3 μ V_{p-p}**

APPLICATIONS

- Thermocouple amplifiers
- Strain gauge amplifiers
- Low level signal processing
- High accuracy data acquisition

DESCRIPTION

The LT[®]1001 significantly advances the state-of-the-art of precision operational amplifiers. In the design, processing, and testing of the device, particular attention has been paid to the optimization of the entire distribution of several key parameters. Consequently, the specifications of the lowest cost, commercial temperature device, the LT1001C, have been dramatically improved when compared to equivalent grades of competing precision amplifiers.

Essentially, the input offset voltage of all units is less than 50 μ V (see distribution plot below). This allows the LT1001AM/883 to be specified at 15 μ V. Input bias and offset currents, common-mode and power supply rejection of the LT1001C offer guaranteed performance which were previously attainable only with expensive, selected grades of other devices. Power dissipation is nearly halved compared to the most popular precision op amps, without adversely affecting noise or speed performance. A beneficial by-product of lower dissipation is decreased warm-up drift. Output drive capability of the LT1001 is also enhanced with voltage gain guaranteed at 10mA of load current. For similar performance in a dual precision op amp, with guaranteed matching specifications, see the LT1002. Shown below is a platinum resistance thermometer application.

LT, LTC and LT are registered trademarks of Linear Technology Corporation.

TYPICAL APPLICATION

**Linearized Platinum Resistance Thermometer
with $\pm 0.025^{\circ}$ C Accuracy Over 0 to 100 $^{\circ}$ C**

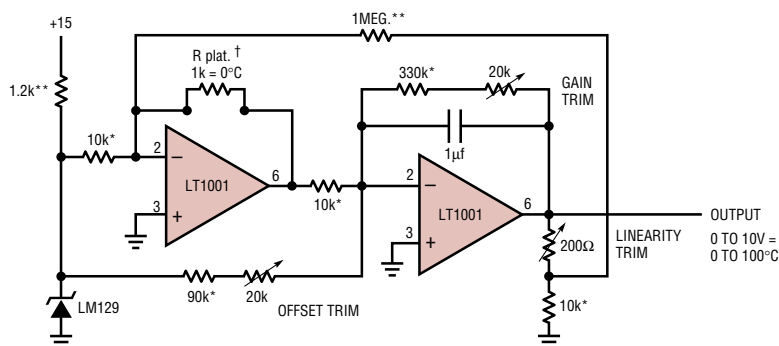

* ULTRONIX 105A WIREWOUND
 ** 1% FILM
 † PLATINUM RTD
 118MF (ROSEMOUNT, INC.)

‡ Trim sequence: trim offset (0 $^{\circ}$ C = 1000.0 Ω),
 trim linearity (35 $^{\circ}$ C = 1138.7 Ω), trim gain
 (100 $^{\circ}$ C = 1392.6 Ω). Repeat until all three
 points are fixed with $\pm 0.025^{\circ}$ C.

1001 TA01

**Typical Distribution
of Offset Voltage
 $V_S = \pm 15V, T_A = 25^{\circ}C$**

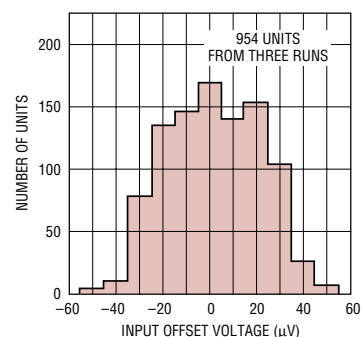

1001 TA02

LT1001

ABSOLUTE MAXIMUM RATINGS

(Note 1)

Supply Voltage	±22V
Differential Input Voltage	±30V
Input Voltage	±22V
Output Short Circuit Duration	Indefinite

Operating Temperature Range

LT1001AM/LT1001M (OBSOLETE) ..	-55°C to 150°C
LT1001AC/LT1001C	0°C to 125°C
Storage: All Devices	-65°C to 150°C
Lead Temperature (Soldering, 10 sec.)	300°C

PACKAGE/ORDER INFORMATION

<p>TOP VIEW</p> <p>OFFSET ADJUST</p> <p>1 8</p> <p>2 7</p> <p>3 6</p> <p>4 5</p> <p>5 NC</p> <p>6 OUT</p> <p>7 V+</p> <p>8 Vos TRIM</p> <p>-IN 2</p> <p>+IN 3</p> <p>V- (CASE) 4</p> <p>H PACKAGE METAL CAN</p> <p>$T_{JMAX} = 150^{\circ}C, \theta_{JA} = 150^{\circ}C/W, \theta_{JC} = 45^{\circ}C/W$</p>	ORDER PART NUMBER	<p>TOP VIEW</p> <p>1 8</p> <p>2 7</p> <p>3 6</p> <p>4 5</p> <p>5 NC</p> <p>6 OUT</p> <p>7 V+</p> <p>8 Vos TRIM</p> <p>-IN 2</p> <p>+IN 3</p> <p>V- 4</p> <p>N8 PACKAGE 8 PIN PLASTIC DIP</p> <p>S8 PACKAGE 8 PIN PLASTIC SO</p> <p>$T_{JMAX} = 150^{\circ}C, \theta_{JA} = 130^{\circ}C/W (N)$</p> <p>$T_{JMAX} = 150^{\circ}C, \theta_{JA} = 150^{\circ}C/W (S)$</p>	ORDER PART NUMBER
	<p>LT1001AMH/883</p> <p>LT1001MH</p> <p>LT1001ACH</p> <p>LT1001CH</p>		<p>LT1001ACN8</p> <p>LT1001CN8</p> <p>LT1001CS8</p>
<p>OBSOLETE PACKAGE</p> <p>Consider the N8 and S8 Packages for Alternate Source</p>		<p>J8 PACKAGE 8 PIN HERMETIC DIP</p> <p>$T_{JMAX} = 150^{\circ}C, \theta_{JA} = 100^{\circ}C/W (J)$</p>	S8 PART MARKING
			<p>1001</p>
			ORDER PART NUMBER
			<p>LT1001AMJ8/883</p> <p>LT1001MJ8</p> <p>LT1001ACJ8</p> <p>LT1001CJ8</p>
			<p>OBSOLETE PACKAGE</p> <p>Consider the N8 and S8 Packages for Alternate Source</p>

Consult LTC Marketing for parts specified with wider operating temperature ranges.

ELECTRICAL CHARACTERISTICS

The ● denotes the specifications which apply over the full operating temperature range, otherwise specifications are at $T_A = 25^{\circ}C$. $V_S = \pm 15V$, unless otherwise noted

SYMBOL	PARAMETER	CONDITIONS	LT1001AM/883 LT1001AC			LT1001M/LT1001C			UNITS	
			MIN	TYP	MAX	MIN	TYP	MAX		
V_{OS}	Input Offset Voltage	Note 2	LT1001AM/883		7	15	18		60	μV
			LT1001AC		10	25				
$\frac{\Delta V_{OS}}{\Delta Time}$	Long Term Input Offset Voltage Stability	Notes 3 and 4			0.2	1.0	0.3	1.5		μV/month
I_{OS}	Input Offset Current				0.3	2.0	0.4	3.8		nA
I_b	Input Bias Current				±0.5	±2.0	±0.7	±4.0		nA
e_n	Input Noise Voltage	0.1Hz to 10Hz (Note 3)			0.3	0.6	0.3	0.6		μV _{p-p}
e_n	Input Noise Voltage Density	$f_0 = 10Hz$ (Note 6) $f_0 = 1000Hz$ (Note 3)			10.3	18.0	10.5	18.0		nV \sqrt{Hz}
					9.6	11.0	9.8	11.0		nV \sqrt{Hz}
A_{VOL}	Large Signal Voltage Gain	$R_L \geq 2k\Omega, V_0 = \pm 12V$ $R_L \geq 1k\Omega, V_0 = \pm 10V$	450	800	400	800				V/mV
			300	500	250	500				V/mV
CMRR	Common Mode Rejection Ratio	$V_{CM} = \pm 13V$	114	126	110	126				dB
PSRR	Power Supply Rejection Ratio	$V_S = \pm 3V$ to $\pm 18V$	110	123	106	123				dB
R_{in}	Input Resistance Differential Mode		30	100	15	80				MΩ

1001fb

ELECTRICAL CHARACTERISTICS The ● denotes the specifications which apply over the full operating temperature range, otherwise specifications are at $T_A = 25^\circ\text{C}$. $V_S = \pm 15\text{V}$, $T_A = 25^\circ\text{C}$, unless otherwise noted

SYMBOL	PARAMETER	CONDITIONS	LT1001AM/883			LT1001M/LT1001C			UNITS	
			MIN	TYP	MAX	MIN	TYP	MAX		
	Input Voltage Range		±13	±14		±13	±14		V	
V_{OUT}	Maximum Output Voltage Swing	$R_L \geq 2\text{k}\Omega$	±13	±14		±13	±14		V	
		$R_L \geq 1\text{k}\Omega$	±12	±13.5		±12	±13.5		V	
S_R	Slew Rate	$R_L \geq 2\text{k}\Omega$ (Note 5)	0.1	0.25		0.1	0.25		V/ μs	
GBW	Gain-Bandwidth Product	(Note 5)	0.4	0.8		0.4	0.8		MHz	
P_d	Power Dissipation	No load		46	75		48	80		mW
		No load, $V_S = \pm 3\text{V}$		4	6		4	8		mW

$V_S = \pm 15\text{V}$, $-55^\circ\text{C} \leq T_A \leq 125^\circ\text{C}$, unless otherwise noted

SYMBOL	PARAMETER	CONDITIONS	LT1001AM/883			LT1001M			UNITS
			MIN	TYP	MAX	MIN	TYP	MAX	
V_{OS}	Input Offset Voltage		●	30	60		45	160	μV
$\frac{\Delta V_{OS}}{\Delta \text{Temp}}$	Average Offset Voltage Drift		●	0.2	0.6		0.3	1.0	$\mu\text{V}/^\circ\text{C}$
I_{OS}	Input Offset Current		●	0.8	4.0		1.2	7.6	nA
I_B	Input Bias Current		●	±1.0	±4.0		±1.5	±8.0	nA
A_{VOL}	Large Signal Voltage Gain	$R_L \geq 2\text{k}\Omega$, $V_O = \pm 10\text{V}$	●	300	700		200	700	V/mV
CMRR	Common Mode Rejection Ratio	$V_{CM} = \pm 13\text{V}$	●	110	122		106	120	dB
PSRR	Power Supply Rejection Ratio	$V_S = \pm 3$ to $\pm 18\text{V}$	●	104	117		100	117	dB
	Input Voltage Range		●	±13	±14		±13	±14	V
V_{OUT}	Output Voltage Swing	$R_L \geq 2\text{k}\Omega$	●	±12.5	±13.5		±12.0	±13.5	V
P_d	Power Dissipation	No load	●	55	90		60	100	mW

$V_S = \pm 15\text{V}$, $0^\circ\text{C} \leq T_A \leq 70^\circ\text{C}$, unless otherwise noted

SYMBOL	PARAMETER	CONDITIONS	LT1001AC			LT1001C			UNITS
			MIN	TYP	MAX	MIN	TYP	MAX	
V_{OS}	Input Offset Voltage		●	20	60		30	110	μV
$\frac{\Delta V_{OS}}{\Delta \text{Temp}}$	Average Offset Voltage Drift		●	0.2	0.6		0.3	1.0	$\mu\text{V}/^\circ\text{C}$
I_{OS}	Input Offset Current		●	0.5	3.5		0.6	5.3	nA
I_B	Input Bias Current		●	±0.7	±3.5		±1.0	±5.5	nA
A_{VOL}	Large Signal Voltage Gain	$R_L \geq 2\text{k}\Omega$, $V_O = \pm 10\text{V}$	●	350	750		250	750	V/mV
CMRR	Common Mode Rejection Ratio	$V_{CM} = \pm 13\text{V}$	●	110	124		106	123	dB
PSRR	Power Supply Rejection Ratio	$V_S = \pm 3\text{V}$ to $\pm 18\text{V}$	●	106	120		103	120	dB
	Input Voltage Range		●	±13	±14		±13	±14	V
V_{OUT}	Output Voltage Swing	$R_L \geq 2\text{k}\Omega$	●	±12.5	±13.8		±12.5	±13.8	V
P_d	Power Dissipation	No load	●	50	85		55	90	mW

Note 1: Absolute Maximum Ratings are those values beyond which the life of a device may be impaired.

Note 2: Offset voltage for the LT1001AM/883 and LT1001AC are measured after power is applied and the device is fully warmed up. All other grades are measured with high speed test equipment, approximately 1 second after power is applied. The LT1001AM/883 receives 168 hr. burn-in at 125°C . or equivalent.

Note 3: This parameter is tested on a sample basis only.

Note 4: Long Term Input Offset Voltage Stability refers to the averaged trend line of V_{OS} versus Time over extended periods after the first 30 days of operation. Excluding the initial hour of operation, changes in V_{OS} during the first 30 days are typically $2.5\mu\text{V}$.

Note 5: Parameter is guaranteed by design.

Note 6: 10Hz noise voltage density is sample tested on every lot. Devices 100% tested at 10Hz are available on request.

TYPICAL PERFORMANCE CHARACTERISTICS

Typical Distribution of Offset Voltage Drift with Temperature

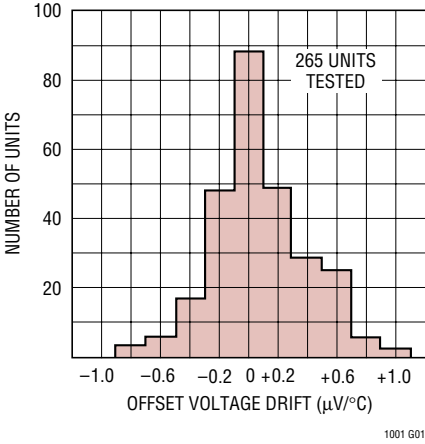

Offset Voltage Drift with Temperature of Representative Units

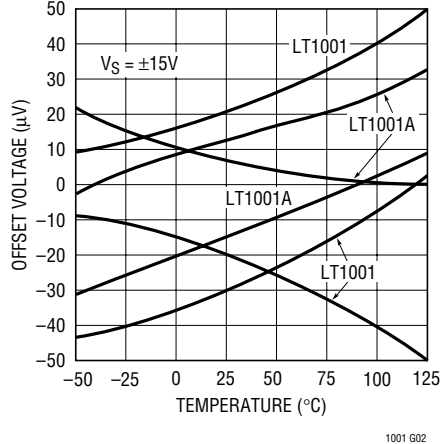

Warm-Up Drift

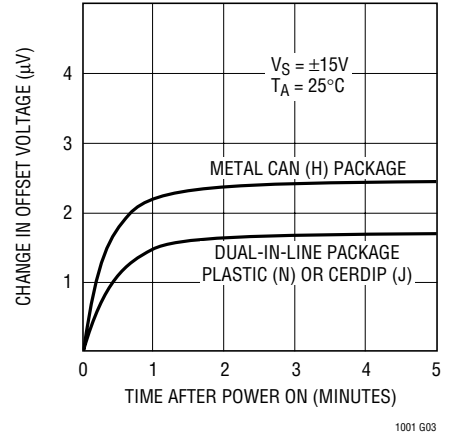

0.1Hz to 10Hz Noise

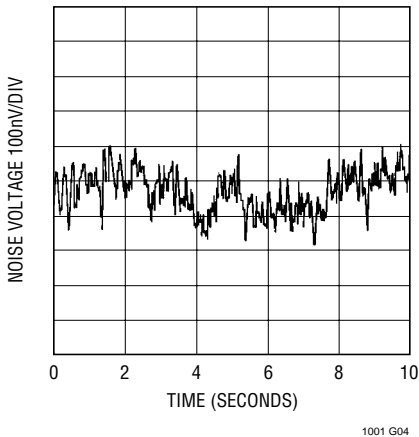

Noise Spectrum

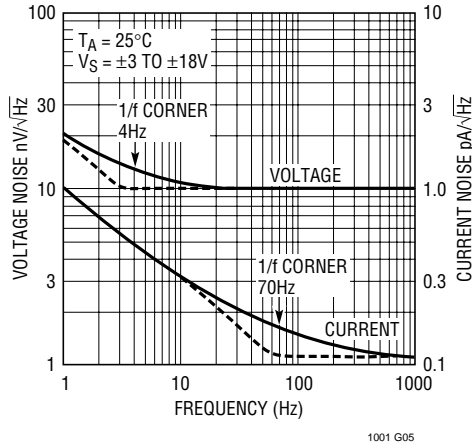

Long Term Stability of Four Representative Units

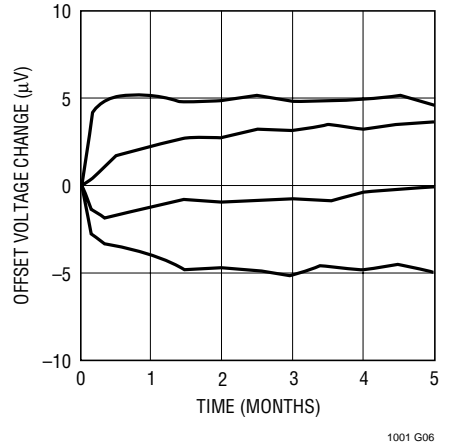

Input Bias and Offset Current vs Temperature

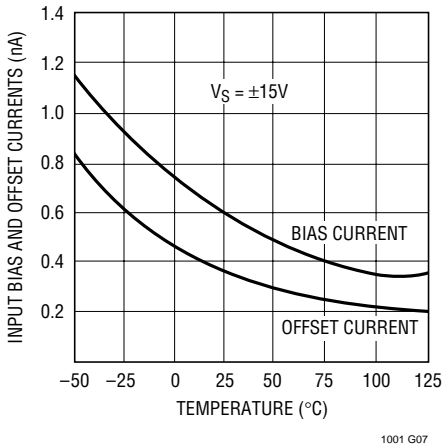

Input Bias Current Over the Common Mode Range

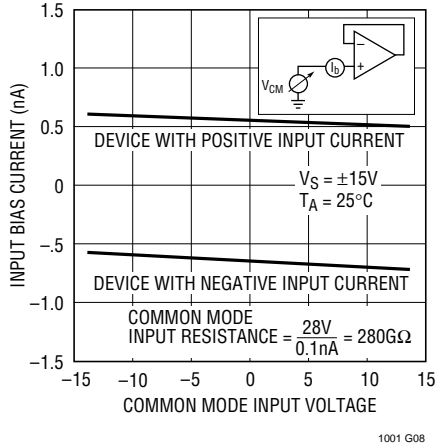

Input Bias Current vs Differential Input Voltage

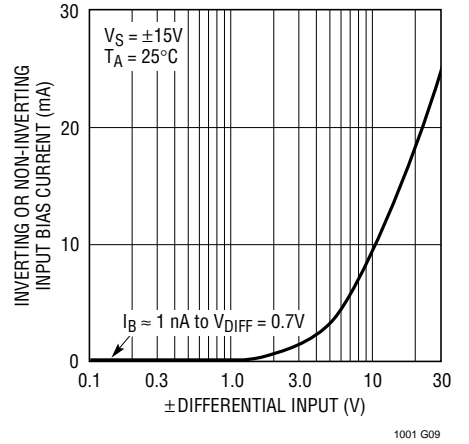

TYPICAL PERFORMANCE CHARACTERISTICS

Open Loop Voltage Gain vs Temperature

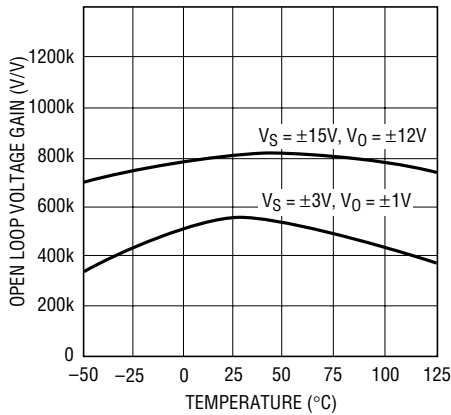

Open Loop Voltage Gain Frequency Response

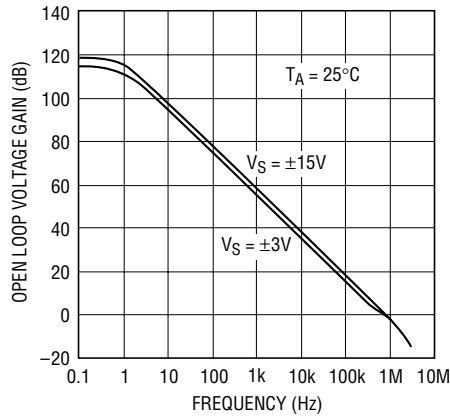

Gain, Phase Shift vs Frequency

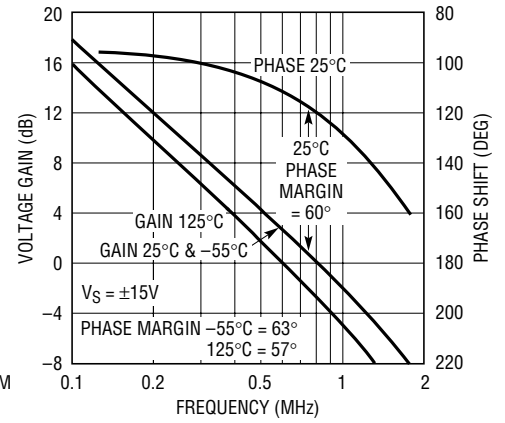

Common Mode Limit vs Temperature

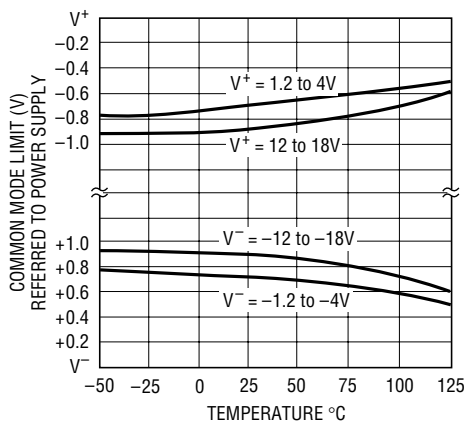

Common Mode Rejection Ratio vs Frequency

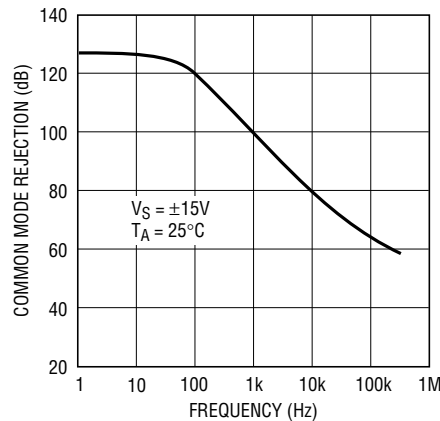

Power Supply Rejection Ratio vs Frequency

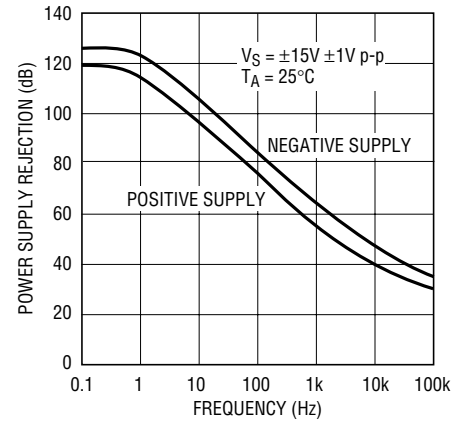

Supply Current vs Supply Voltage

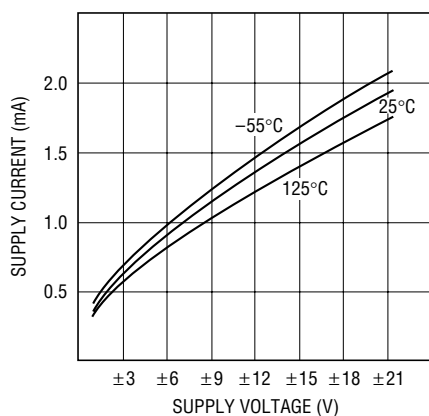

Output Swing vs Load Resistance

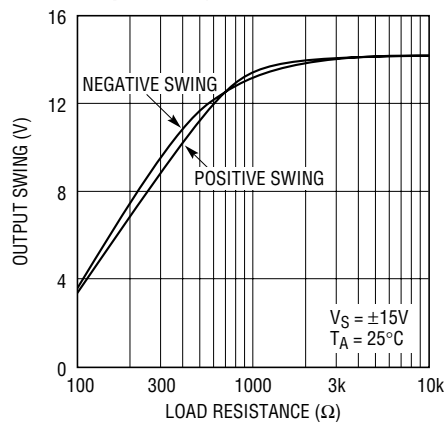

Output Short-Circuit Current vs Time

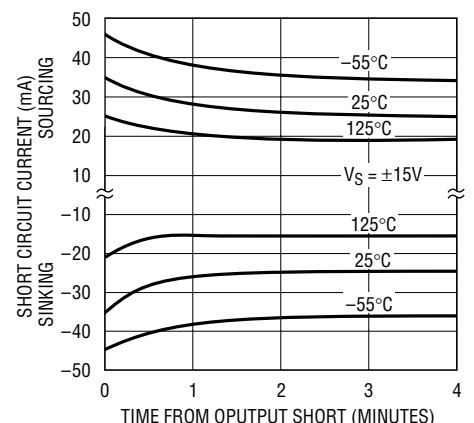

TYPICAL PERFORMANCE CHARACTERISTICS

Small Signal Transient Response

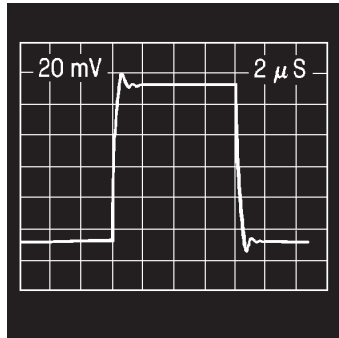

$A_V = +1, C_L = 50\text{pF}$

1001 G19

Voltage Follower Overshoot vs Capacitive Load

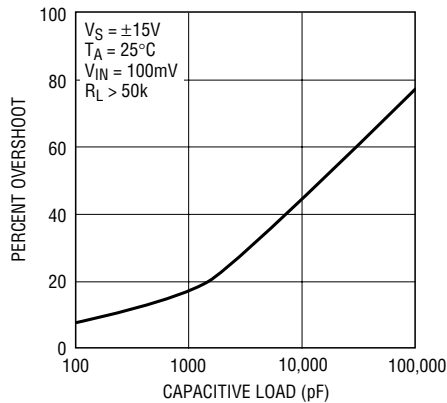

1001 G20

Small Signal Transient Response

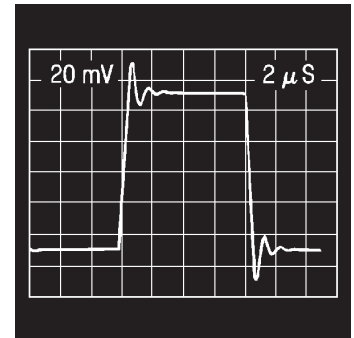

$A_V = +1, C_L = 1000\text{pF}$

1001 G21

Large Signal Transient Response

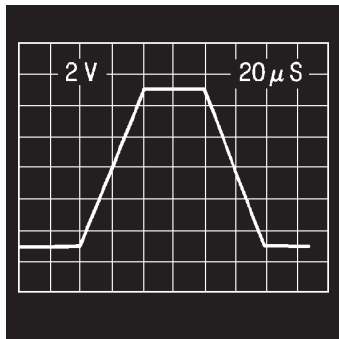

1001 G22

Maximum Undistorted Output vs. Frequency

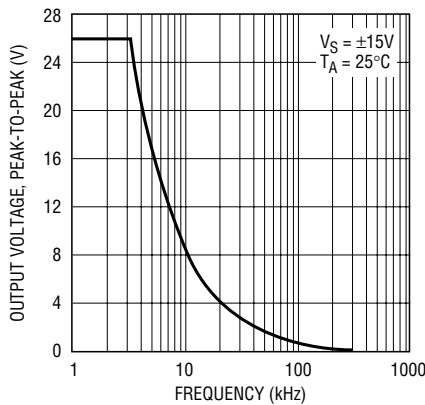

1001 G23

Closed Loop Output Impedance

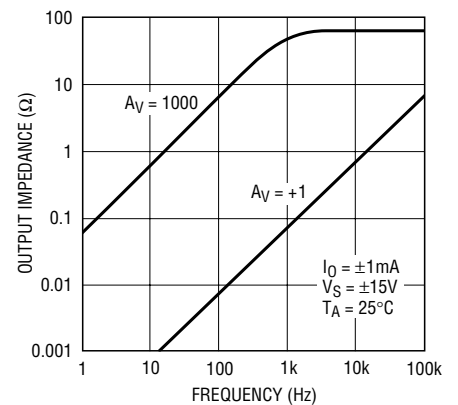

1001 G24

APPLICATIONS INFORMATION

Application Notes and Test Circuits

The LT1001 series units may be inserted directly into OP-07, OP-05, 725, 108A or 101A sockets with or without removal of external frequency compensation or nulling components. The LT1001 can also be used in 741, LF156 or OP-15 applications provided that the nulling circuitry is removed.

The LT1001 is specified over a wide range of power supply voltages from $\pm 3\text{V}$ to $\pm 18\text{V}$. Operation with lower supplies is possible down to $\pm 1.2\text{V}$ (two Ni-Cad batteries). However, with $\pm 1.2\text{V}$ supplies, the device is stable only in closed loop gains of +2 or higher (or inverting gain of one or higher).

Unless proper care is exercised, thermocouple effects caused by temperature gradients across dissimilar metals at the contacts to the input terminals, can exceed the inherent drift of the amplifier. Air currents over device leads should be minimized, package leads should be short, and the two input leads should be as close together as possible and maintained at the same temperature.

Test Circuit for Offset Voltage and its Drift with Temperature

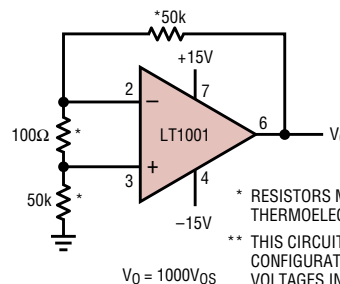

* RESISTORS MUST HAVE LOW THERMOELECTRIC POTENTIAL.

** THIS CIRCUIT IS ALSO USED AS THE BURN-IN CONFIGURATION FOR THE LT1001, WITH SUPPLY VOLTAGES INCREASED TO $\pm 20\text{V}$.

$V_O = 1000V_{OS}$

1001 F01 1001fb

APPLICATIONS INFORMATION

Offset Voltage Adjustment

The input offset voltage of the LT1001, and its drift with temperature, are permanently trimmed at wafer test to a low level. However, if further adjustment of V_{os} is necessary, nulling with a 10k or 20k potentiometer will not degrade drift with temperature. Trimming to a value other than zero creates a drift of $(V_{os}/300)\mu V/^\circ C$, e.g., if V_{os} is

adjusted to $300\mu V$, the change in drift will be $1\mu V/^\circ C$. The adjustment range with a 10k or 20k pot is approximately $\pm 2.5mV$. If less adjustment range is needed, the sensitivity and resolution of the nulling can be improved by using a smaller pot in conjunction with fixed resistors. The example below has an approximate null range of $\pm 100\mu V$.

Improved Sensitivity Adjustment

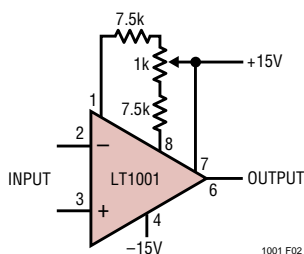

0.1Hz to 10Hz Noise Test Circuit

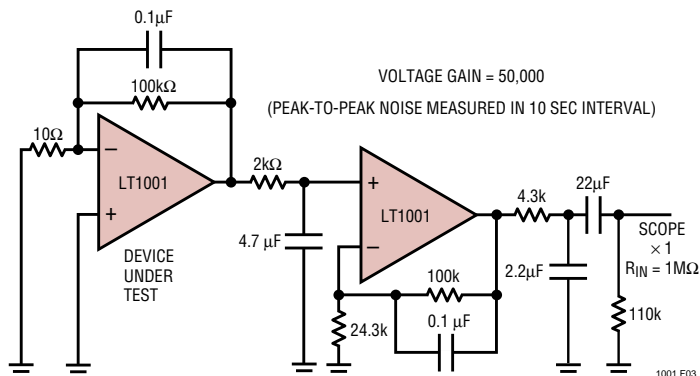

The device under test should be warmed up for three minutes and shielded from air currents.

DC Stabilized 1000v/μsec Op Amp

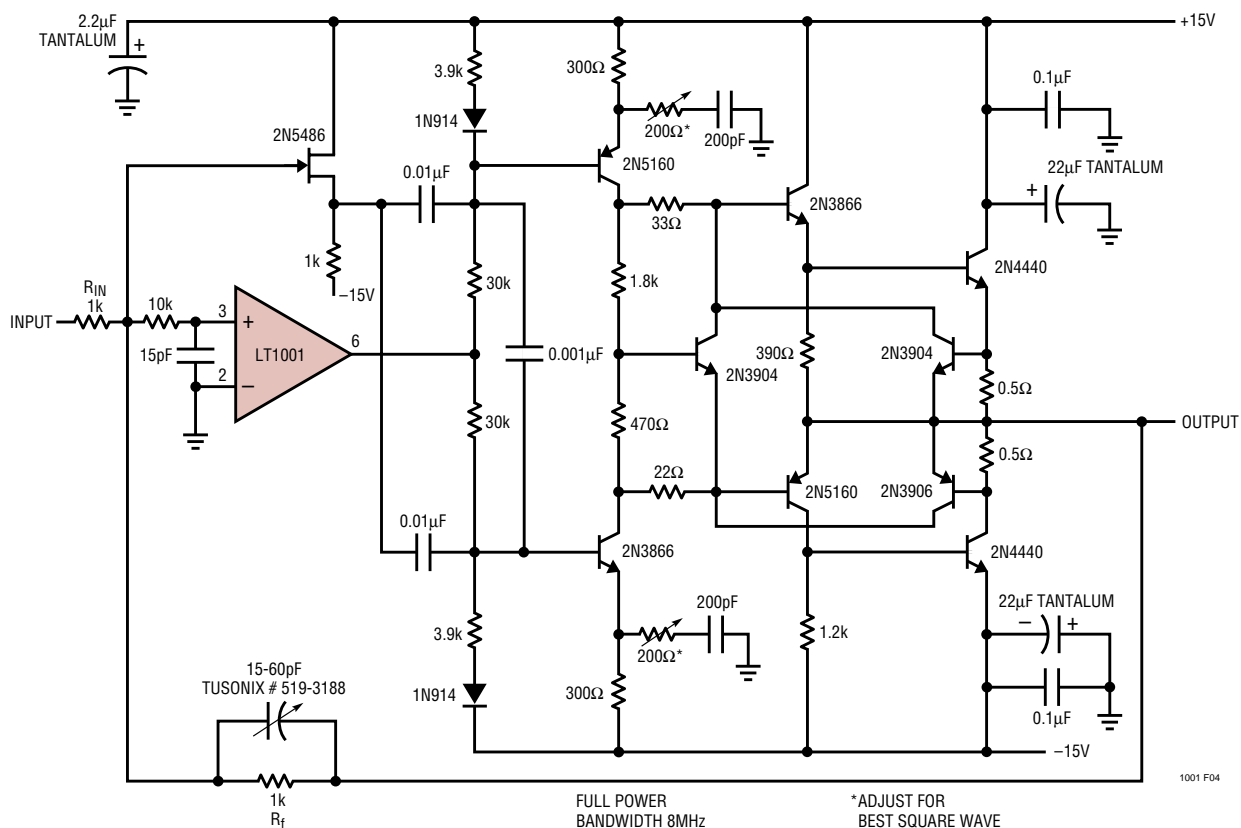

FULL POWER BANDWIDTH 8MHz

*ADJUST FOR BEST SQUARE WAVE AT OUTPUT

TYPICAL APPLICATIONS

Microvolt Comparator with TTL Output

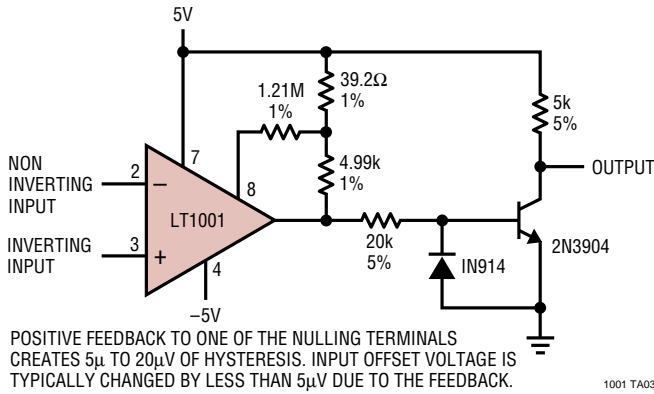

Photodiode Amplifier

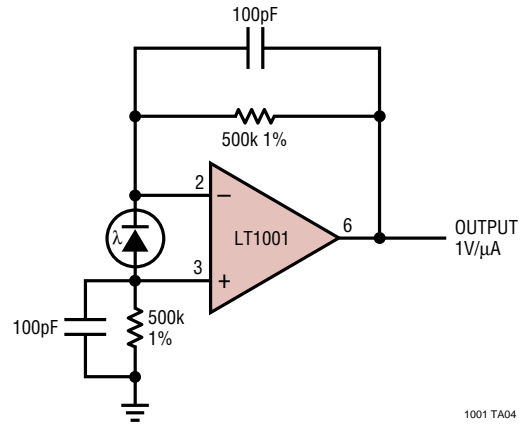

Precision Current Source

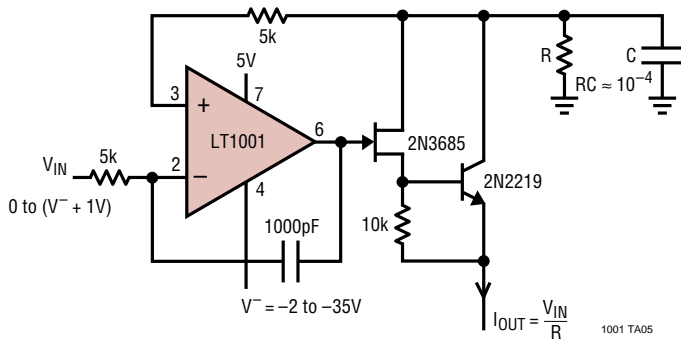

Precision Current Sink

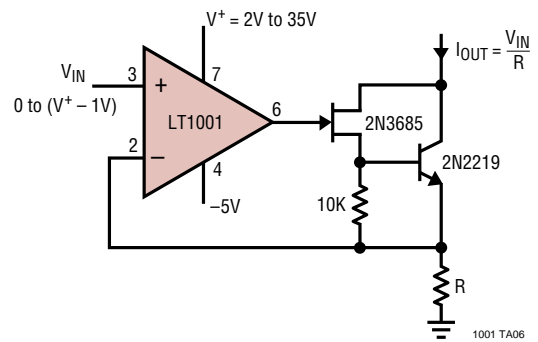

Strain Gauge Signal Conditioner with Bridge Excitation

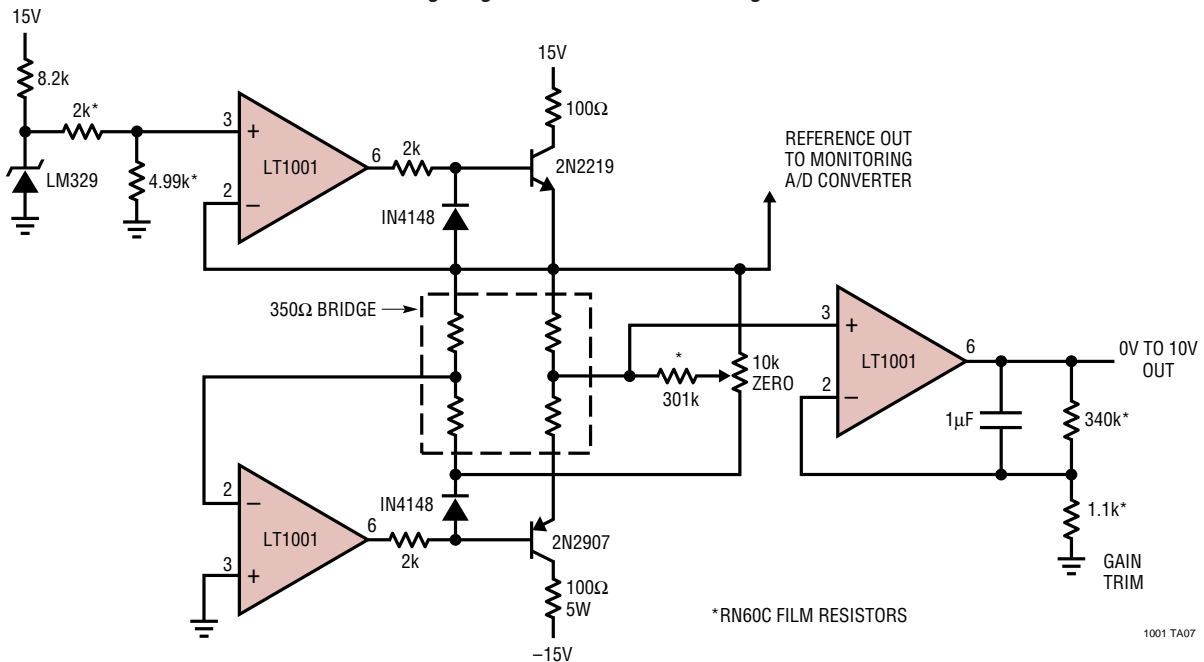

TYPICAL APPLICATIONS

Large Signal Voltage Follower With 0.001% Worst Case Accuracy

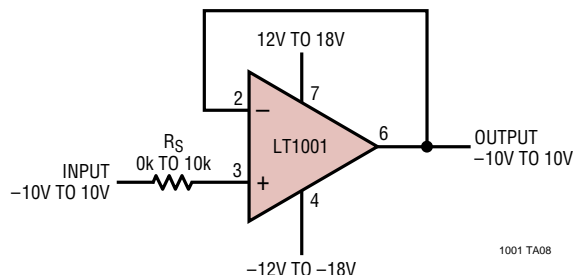

The voltage follower is an ideal example illustrating the overall excellence of the LT1001. The contributing error terms are due to offset voltage, input bias current, voltage gain, common mode and power-supply

rejections. Worst-case summation of guaranteed specifications is tabulated below.

Error	OUTPUT ACCURACY			
	LT1001AM /883 25°C Max.	LT1001C 25°C Max.	LT1001AM /883 -55 to 125°C Max.	LT1001C 0 to 70°C Max.
Offset Voltage	15μV	60μV	60μV	110μV
Bias Current	20μV	40μV	40μV	55μV
Common Mode Rejection	20μV	30μV	30μV	50μV
Power Supply Rejection	18μV	30μV	36μV	42μV
Voltage Gain	22μV	25μV	33μV	40μV
Worst-case Sum	95μV	185μV	199μV	297μV
Percent of Full Scale (=20V)	0.0005%	0.0009%	0.0010%	0.0015%

Thermally Controlled NiCad Charger

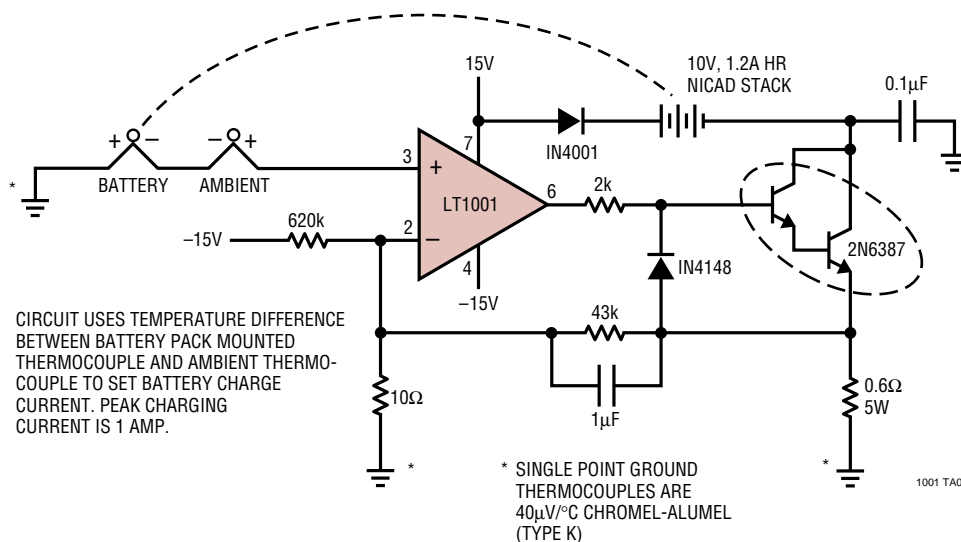

Precision Absolute Value Circuit

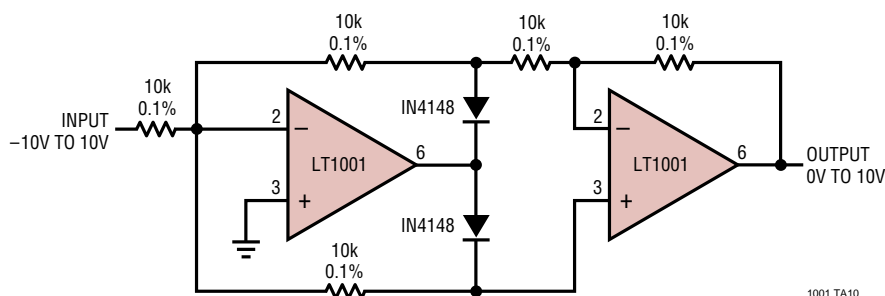

TYPICAL APPLICATIONS

Instrumentation Amplifier with $\pm 300V$ Common Mode Range and CMRR > 150dB

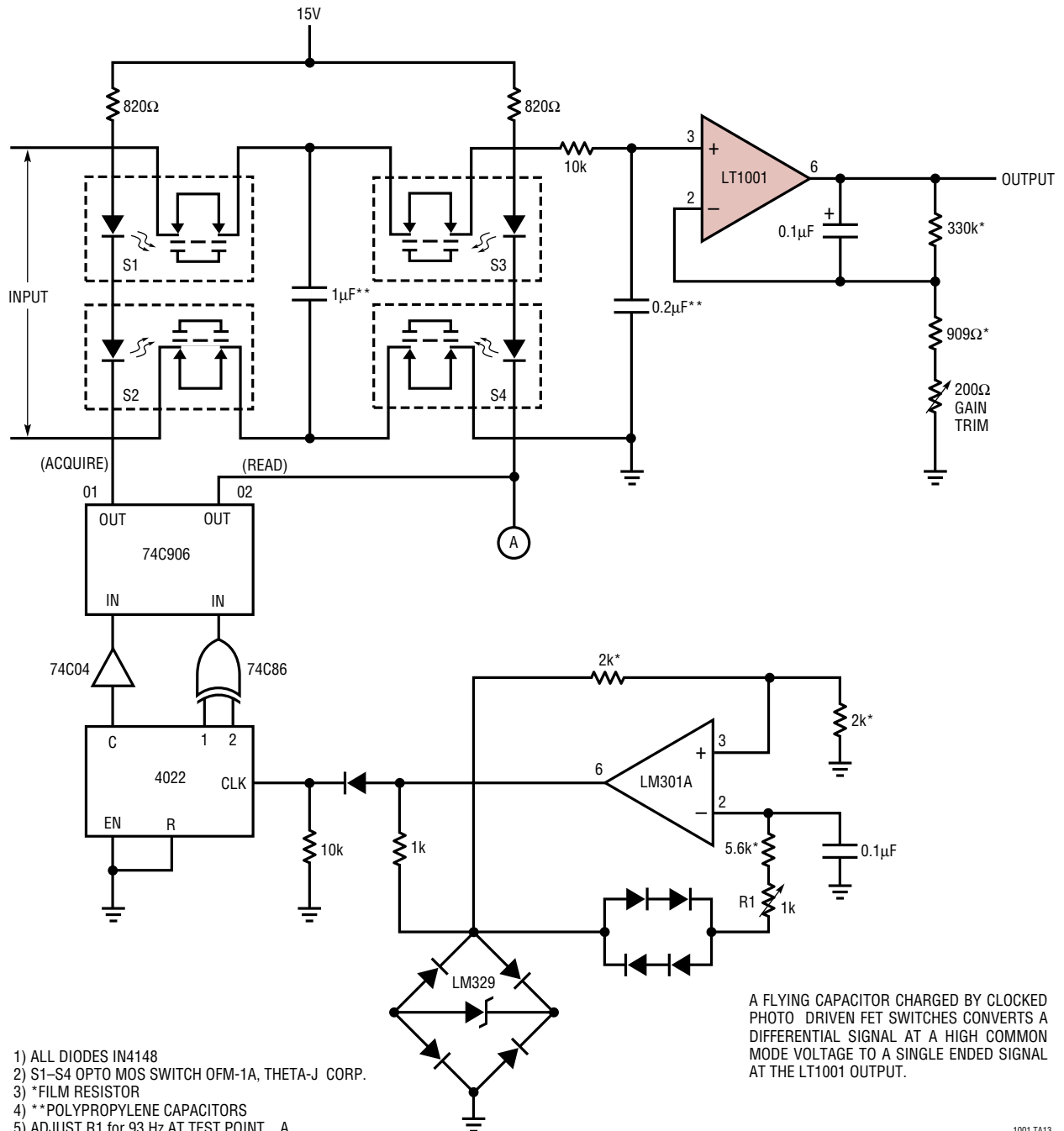

1001 TA13

SCHEMATIC DIAGRAM

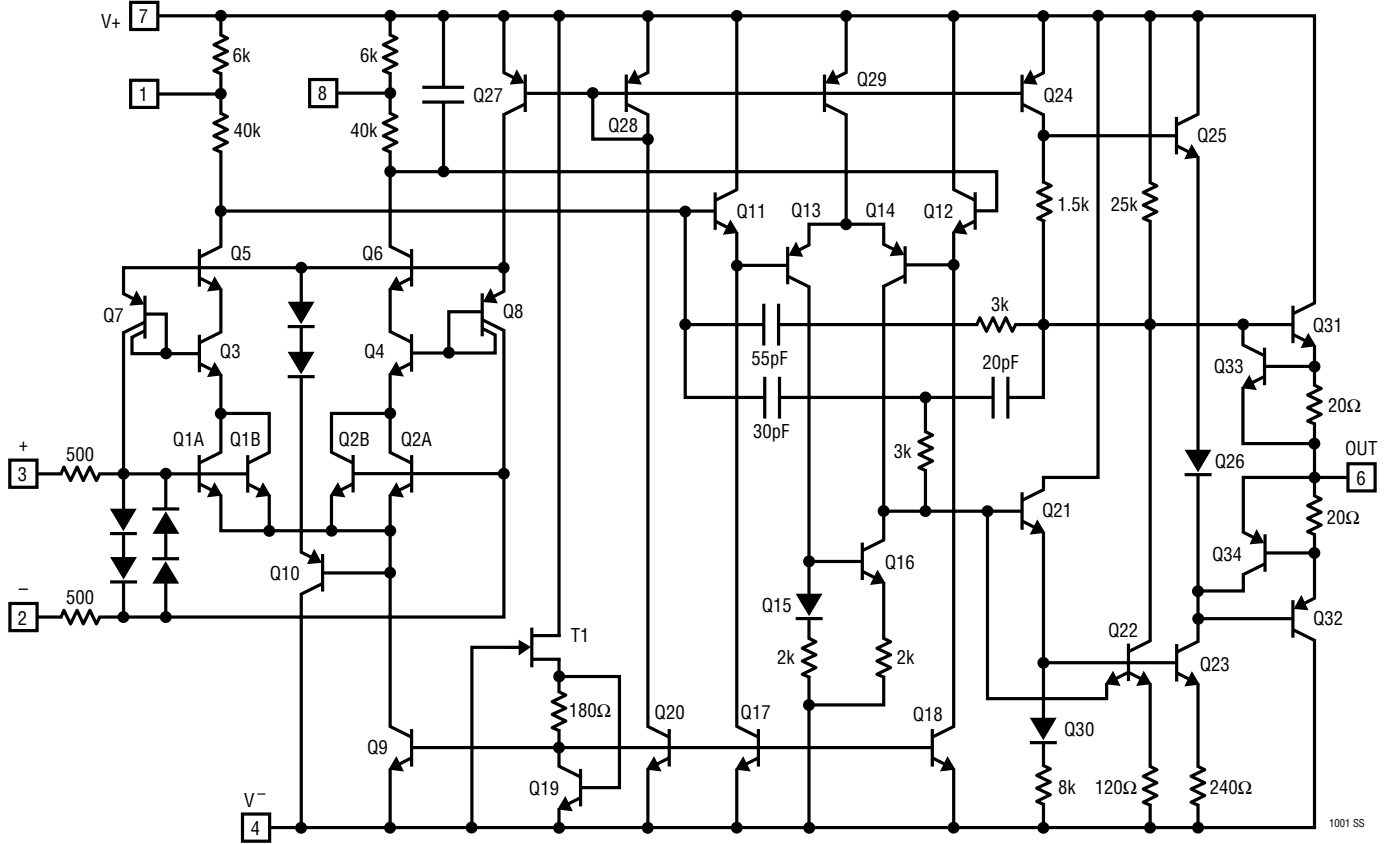

PACKAGE DESCRIPTION

H Package
8-Lead TO-5 Metal Can (.200 Inch PCD)
 (Reference LTC DWG # 05-08-1320)

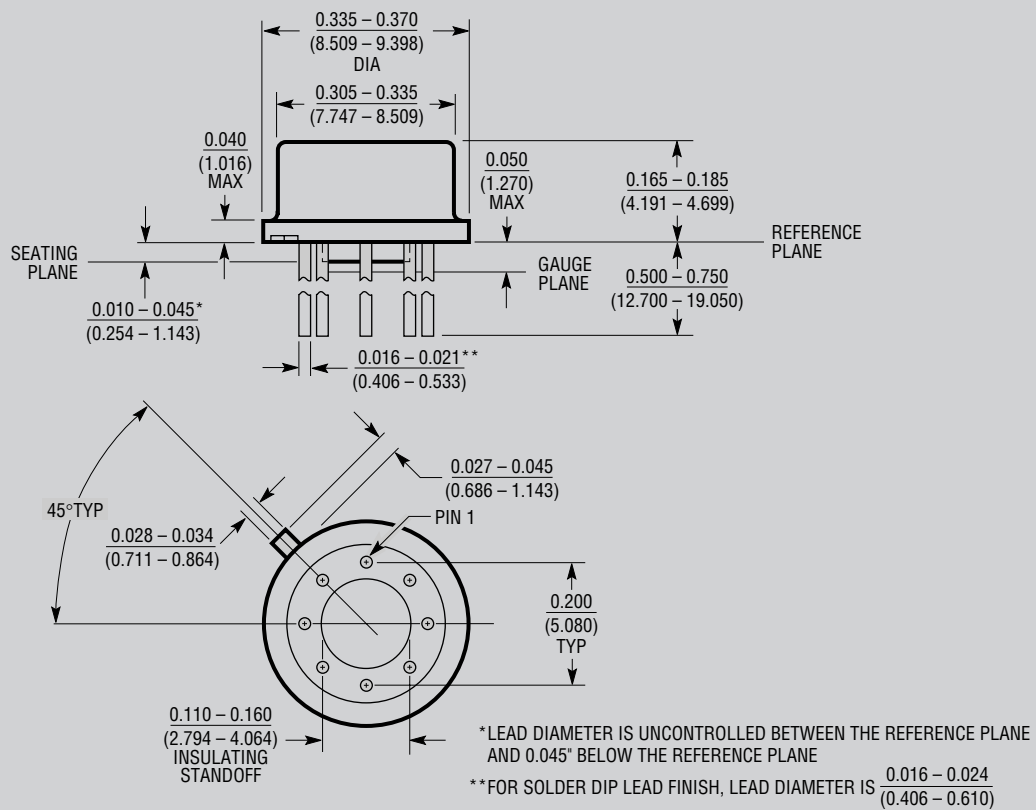

H8(TO-5) 0.200 PCD 1197

OBSOLETE PACKAGE

PACKAGE DESCRIPTION

J8 Package
8-Lead CERDIP (Narrow .300 Inch, Hermetic)
 (Reference LTC DWG # 05-08-1110)

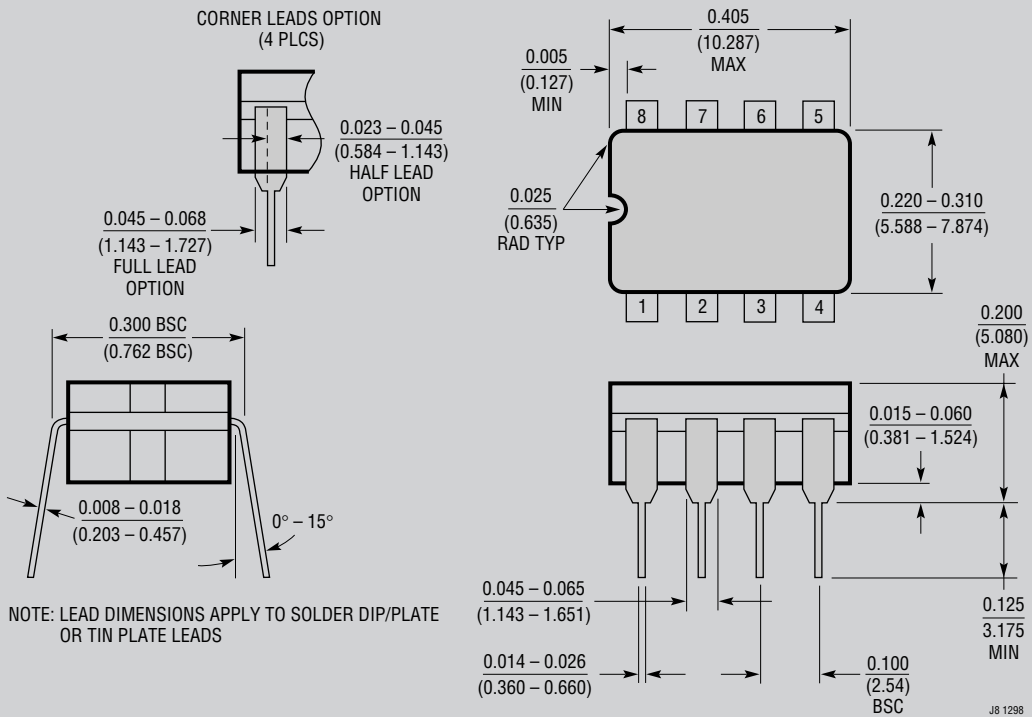

OBSOLETE PACKAGE

PACKAGE DESCRIPTION

N8 Package
8-Lead PDIP (Narrow .300 Inch)
 (Reference LTC DWG # 05-08-1510)

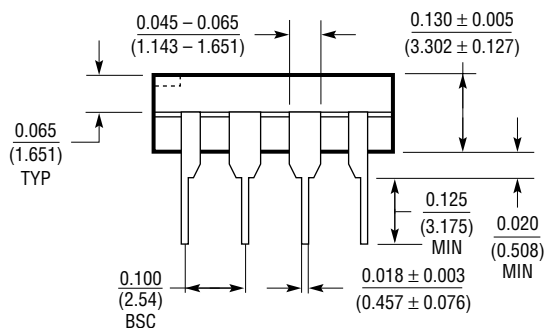
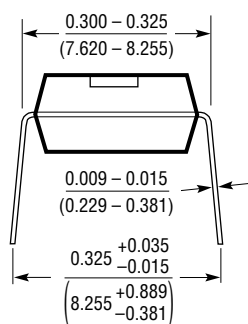
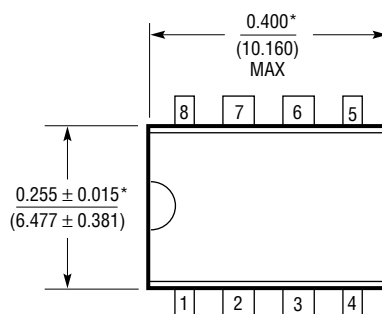

*THESE DIMENSIONS DO NOT INCLUDE MOLD FLASH OR PROTRUSIONS.
 MOLD FLASH OR PROTRUSIONS SHALL NOT EXCEED 0.010 INCH (0.254mm)

N8 1098

PACKAGE DESCRIPTION

S8 Package
8-Lead Plastic Small Outline (Narrow .150 Inch)
 (Reference LTC DWG # 05-08-1610)

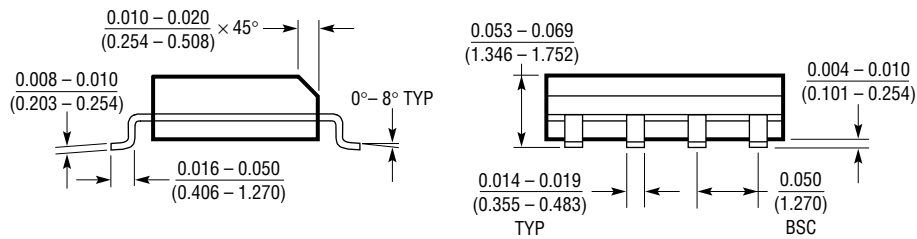
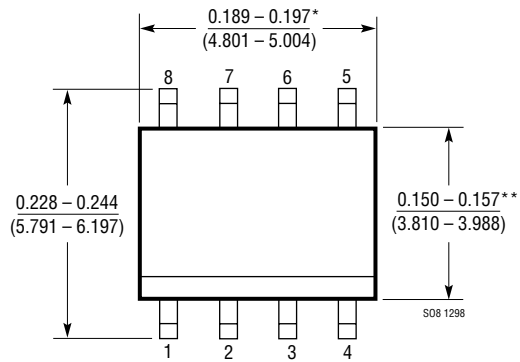

*DIMENSION DOES NOT INCLUDE MOLD FLASH. MOLD FLASH SHALL NOT EXCEED 0.006" (0.152mm) PER SIDE

**DIMENSION DOES NOT INCLUDE INTERLEAD FLASH. INTERLEAD FLASH SHALL NOT EXCEED 0.010" (0.254mm) PER SIDE

Looking for pricing, stock, or lifecycle information?

Click below to explore more details on WIN SOURCE:

 [View LT1001ACN8#PBF on WIN SOURCE](#)

 [Linear Technology](#) Information

Optimize Your Supply Chain with WIN SOURCE Solutions

-  Global Sourcing Solution
-  Obsolete Management
-  Cost Control Management
-  Shortage Management
-  Alternative Solution
-  Excess Inventory Management