



**THE DATASHEET OF
FAM65V05DF1**



Auto SPM[®] Series Automotive 3-Phase IGBT Smart Power Module

FAM65V05DF1

General Description

FAM65V05DF1 is an advanced Auto SPM module providing a fully-featured high-performance auxiliary inverter output stage for hybrid and electric vehicles. These modules integrate optimized gate drive of the built-in IGBTs to minimize EMI and losses, while also providing various protection features, in a compact 12 cm² footprint.

Features

- Automotive SPM in 27 Pin DIP Package
- 650 V/50 A 3-phase IGBT Module with Low Loss IGBTs and Soft Recovery Diodes Optimized for Motor Control Applications
- Integrated Gate Drivers with Internal VS connection, Under Voltage lockout, Over-current shutdown, Temperature Sensing Unit and Fault reporting
- Electrically Isolated AlN Substrate with Low R_{θjc}
- Module Serialization for Full Traceability
- UL Certified No. E209204 (UL 1557)
- Pb-Free, Halid Free and RoHS Compliant
- AEC & AQC324 Qualified and PPAP Capable

Applications and Benefits

Automotive high voltage auxiliary motors such as air conditioning compressor and oil pump.

- Compact Design
- Simplified PCB Layout and Low EMI
- Simplified Assembly
- High Reliability

Related Resources

- [AN-8422](#) – 650 V Auto SPM Series; Automotive 3-Phase IGBT Smart Power Module User’s Guide

3D Package Drawing
 (Click to Activate 3D Content)

ASPM27-CCA
 CASE MODCB

MARKING DIAGRAM

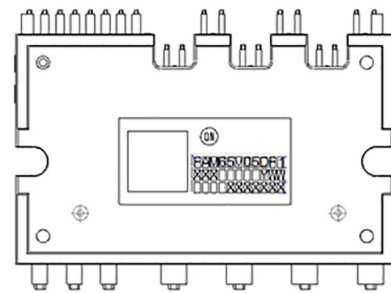

ON	= onsemi Logo
FAM65V05DF1	= Specific Device Code
XXX	= Lot Number
Y	= Year
WW	= Work Week
0000001	= Serial Number

ORDERING INFORMATION

See detailed ordering and shipping information on page 7 of this data sheet.

FAM65V05DF1

PIN CONFIGURATION

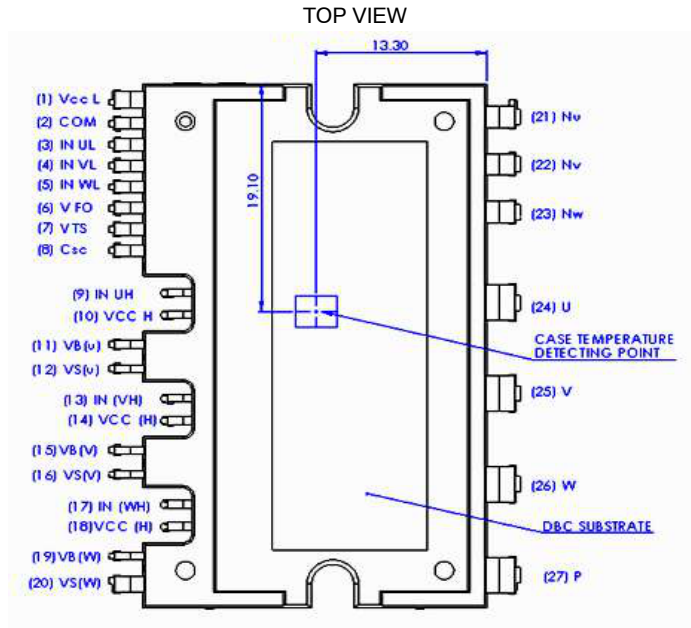

Figure 1. Pin Configuration

PIN DESCRIPTION

Pin Number	Name	Description
1	VCC (L)	Low-side Common Bias Voltage for IC and IGBTs Driving
2	COM	Common Supply Ground
3	IN (UL)	Signal Input for Low-side U Phase
4	IN (VL)	Signal Input for Low-side V Phase
5	IN (WL)	Signal Input for Low-side W Phase
6	VFO	Fault Output
7	VTS	Output for LVIC temperature sense
8	CSC	Capacitor (Low-pass Filter) for Short-Current Detection Input
9	IN (UH)	Signal Input for High-side U Phase
10	VCC (H)	High-side Common Bias Voltage for IC and IGBTs Driving
11	VB (U)	High-side Bias Voltage for U Phase IGBT Driving
12	VS (U)	High-side Bias Voltage Ground for U Phase IGBT Driving
13	IN (VH)	Signal Input for High-side V Phase
14	VCC (H)	High-side Common Bias Voltage for IC and IGBTs Driving
15	VB (V)	High-side Bias Voltage for V Phase IGBT Driving
16	VS (V)	High-side Bias Voltage Ground for V Phase IGBT Driving
17	IN (WH)	Signal Input for High-side W Phase
18	VCC (H)	High-side Common Bias Voltage for IC and IGBTs Driving
19	VB (W)	High-side Bias Voltage for W Phase IGBT Driving
20	VS (W)	High-side Bias Voltage Ground for W Phase IGBT Driving
21	NU	Negative DC-Link Input for U Phase
22	NV	Negative DC-Link Input for V Phase

FAM65V05DF1

PIN DESCRIPTION (continued)

Pin Number	Name	Description
23	NW	Negative DC-Link Input for W Phase
24	U	Output for U Phase
25	V	Output for V Phase
26	W	Output for W Phase
27	P	Positive DC-Link Input

INTERNAL EQUIVALENT CIRCUIT AND INPUT/OUTPUT PINS

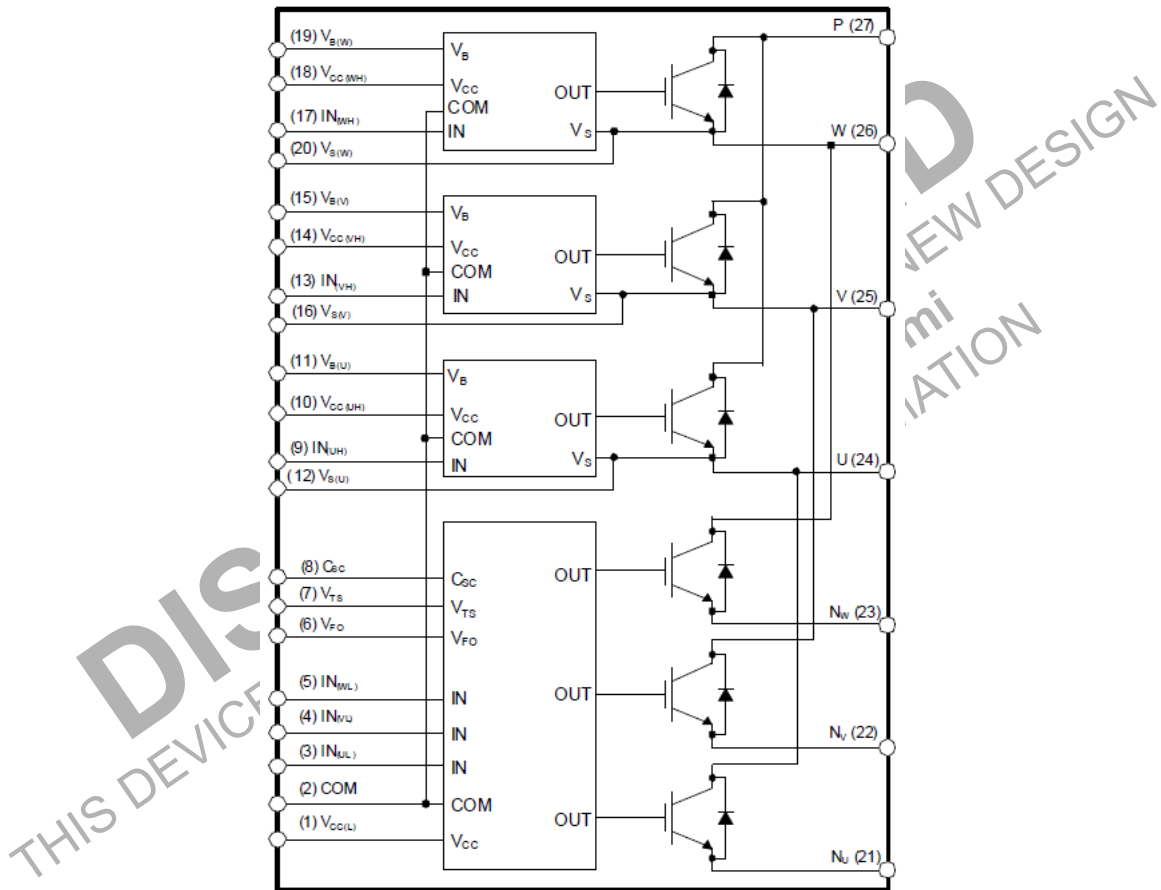

Figure 2. Schematic

FAM65V05DF1

GATE DRIVERS BLOCK DIAGRAM

High Side Gate Driver (x3 Single Channel)

- Control circuit under-voltage (UV) protection
- 3.3 V/5 V CMOS/LSTTL compatible, Schmitt trigger input

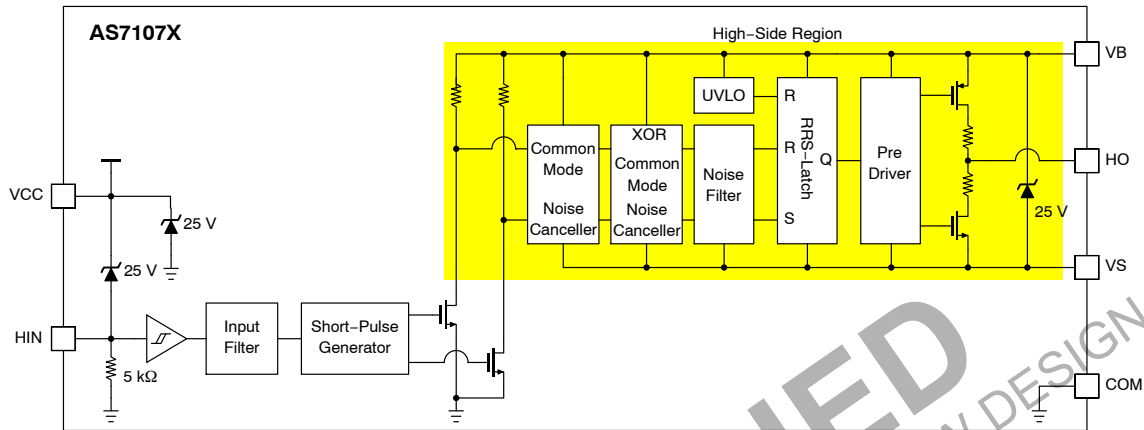

Figure 3. High Side Gate Drivers (Block Diagram)

Low Side Gate Driver (x1 Monolithic Three-Channel)

- Control circuit under-voltage (UV) protection
- Short circuit protection (SC)
- Temperature sensing unit
- Fault Output
- 3.3 V/5 V CMOS/LSTTL compatible, Schmitt trigger input

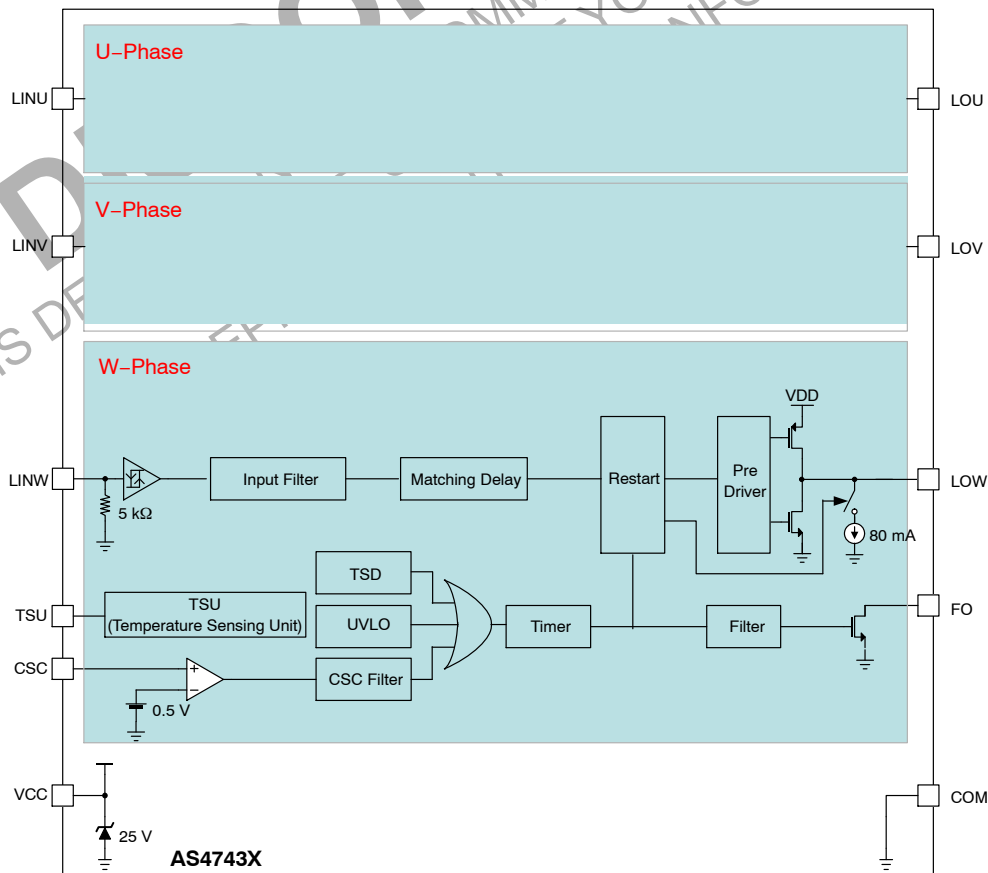

Figure 4. Low Side Gate Drivers (Block Diagram)

FAM65V05DF1

ABSOLUTE MAXIMUM RATINGS (T_J = 25°C, unless otherwise specified)

Symbol	Parameter	Conditions	Rating	Unit
INVERTER PART				
V _{PN}	Supply Voltage	Applied between P– N _U , N _V , N _W	500	V
V _{PN(Surge)}	Supply Voltage (Surge)	Applied between P– N _U , N _V , N _W di/dt ≤ 3 A/ns	575	V
V _{CES}	Collector–Emitter Voltage at the IGBT/Diode	T _J = 25°C	650	V
±I _C	IGBT Continuous Collector Current	T _C = 100°C, T _{Jmax} = 175°C (Note 1)	50	A
±I _{CP}	IGBT Peak Collector Pulse Current	T _C = 100°C, T _{Jmax} = 175°C, V _{CC} = V _{BS} = 15 V, less than 1 ms (Note 6)	150	A
P _C	Collector Dissipation	T _C = 25°C per IGBT	333	W
T _J	Junction Temperature	IGBT/Diode	–40 ~ +175	°C
		Driver IC	–40 ~ +150	°C

CONTROL PART

V _{CC}	Control Supply Voltage	Applied between V _{CC(H)} , V _{CC(L)} – COM	20	V
V _{BS}	High–side Control Bias Voltage	Applied between V _{B(U)} – V _{S(U)} , V _{B(V)} – V _{S(V)} , V _{B(W)} – V _{S(W)}	20	V
V _{IN}	Input Signal Voltage	Applied between IN _(UH) , IN _(VH) , IN _(WH) , IN _(UL) , IN _(VL) , IN _(WL) – COM	–0.3 ~ V _{CC} + 0.3	V
V _{FO}	Fault Output Supply Voltage	Applied between V _{FO} – COM	–0.3 ~ V _{CC} + 0.3	V
I _{FO}	Fault Output Current	Sink Current at V _{FO} Pin	5	mA
V _{SC}	Current Sensing Input Voltage	Applied between C _{SC} – COM	–0.3 ~ V _{CC} + 0.3	V
V _{TS}	Temperature Sense Unit		–0.3 ~ 2/3 × V _{CC}	V

TOTAL SYSTEM

T _{STG}	Storage Temperature		–40 ~ 125	°C
V _{ISO}	Isolation Voltage	60 Hz, Sinusoidal, AC 1 minute, Connection Pins to heat sink plate	2500	V _{rms}
T _{LEAD}	Max Lead Temperature at the Base of the Package During pcb Assembly	No remelt of internal solder joints	200	°C

Stresses exceeding those listed in the Maximum Ratings table may damage the device. If any of these limits are exceeded, device functionality should not be assumed, damage may occur and reliability may be affected.

PACKAGE CHARACTERISTICS

Symbol	Parameter	Conditions	Typ	Max	Unit
R _{th(j-c)Q}	Junction to Case Thermal Resistance (Note 2)	Inverter IGBT part (per IGBT)	–	0.45	°C/W
R _{th(j-c)F}		Inverter FWD part (per DIODE)	–	0.85	°C/W
L _σ	Package Stray Inductance	P to N _U , N _V , N _W (Note 3)	24	–	nH

1. Current limited by package terminal, defined by design.
2. Case temperature measured below the package at the chip center, compliant with MIL STD 883–1012.1 (single chip heating), DBC discoloration allowed, please refer to application note [AN-9190](#) (*Impact of DBC Oxidation on SPM Module Performance*).
3. Stray inductance per phase measured per IEC 60747–15.

FAM65V05DF1

ELECTRICAL CHARACTERISTICS

Symbol	Parameter	Test Conditions	Min	Typ	Max	Unit	
INVERTER PART (T_J as specified)							
$V_{CE(SAT)}$	Collector-Emitter Leakage Current	$V_{CC} = V_{BS} = 15\text{ V}$, $V_{IN} = 5\text{ V}$ $I_C = 50\text{ A}$, $T_J = 25^\circ\text{C}$	-	1.65	-	V	
		$V_{CC} = V_{BS} = 15\text{ V}$, $V_{IN} = 5\text{ V}$ $I_C = 50\text{ A}$, $T_J = 125^\circ\text{C}$	-	1.9	2.4	V	
V_F	FWD Forward Voltage	$V_{IN} = 0\text{ V}$, $I_F = 30\text{ A}$, $T_J = 25^\circ\text{C}$	-	2.1	-	V	
		$V_{IN} = 0\text{ V}$, $I_F = 30\text{ A}$, $T_J = 125^\circ\text{C}$	-	1.9	2.5	V	
HS	t_{ON}	High Side Switching Times $V_{PN} = 300\text{ V}$, $V_{CC} = V_{BS} = 15\text{ V}$ $I_C = 50\text{ A}$ $V_{IN} = 0\text{ V} \leftrightarrow 5\text{ V}$, $L_s = 55\text{ nH}$, Inductive Load $T_J = 25^\circ\text{C}$ (Notes 4, 5)	-	0.73	-	μs	
			$t_{C(ON)}$	-	0.12	-	
			t_{OFF}	-	0.80	-	
			$t_{C(OFF)}$	-	0.14	-	
			t_{rr}	-	0.10	-	
	t_{ON}	High Side Switching Times $V_{PN} = 300\text{ V}$, $V_{CC} = V_{BS} = 15\text{ V}$ $I_C = 50\text{ A}$ $V_{IN} = 0\text{ V} \leftrightarrow 5\text{ V}$, $L_s = 55\text{ nH}$, Inductive Load $T_J = 125^\circ\text{C}$ (Notes 4, 5)	-	0.70	-	μs	
			$t_{C(ON)}$	-	0.15	-	
			t_{OFF}	-	0.87	-	
			$t_{C(OFF)}$	-	0.19	-	
			t_{rr}	-	0.20	-	
LS	t_{ON}	Low Side Switching Times $V_{PN} = 300\text{ V}$, $V_{CC} = V_{BS} = 15\text{ V}$ $I_C = 50\text{ A}$ $V_{IN} = 0\text{ V} \leftrightarrow 5\text{ V}$, $L_s = 55\text{ nH}$, Inductive Load $T_J = 25^\circ\text{C}$ (Notes 4, 5)	-	0.68	-	μs	
			$t_{C(ON)}$	-	0.20	-	
			t_{OFF}	-	0.86	-	
			$t_{C(OFF)}$	-	0.19	-	
			t_{rr}	-	0.14	-	
	t_{ON}	Low Side Switching Times $V_{PN} = 300\text{ V}$, $V_{CC} = V_{BS} = 15\text{ V}$ $I_C = 50\text{ A}$ $V_{IN} = 0\text{ V} \leftrightarrow 5\text{ V}$, $L_s = 55\text{ nH}$, Inductive Load $T_J = 125^\circ\text{C}$ (Notes 4, 5)	-	0.64	-	μs	
			$t_{C(ON)}$	-	0.24	-	
			t_{OFF}	-	0.88	-	
			$t_{C(OFF)}$	-	0.23	-	
			t_{rr}	-	0.20	-	
SCWT	Short Circuit Withstand Time (Note 6)	$V_{CC} = V_{BS} = 15\text{ V}$, $V_{PN} = 450\text{ V}$, $T_J = 25^\circ\text{C}$, Non-repetitive	-	5	-	μs	
I_{CES}	Collector-Emitter Leakage Current for IGBT and Diode in Parallel	$T_J = 25^\circ\text{C}$, $V_{CE} = 650\text{ V}$	-	3	-	μA	
		$T_J = 125^\circ\text{C}$, $V_{CE} = 650\text{ V}$	-	150	1500	μA	

FAM65V05DF1

ELECTRICAL CHARACTERISTICS (continued)

Symbol	Parameter	Test Conditions	Min	Typ	Max	Unit	
CONTROL PART ($T_J = -40^{\circ}\text{C}$ to 150°C , unless otherwise specified, typical values specified at $T_J = 125^{\circ}\text{C}$)							
I_{QCCL}	Quiescent V_{CC} Supply Current	$V_{CC} = 15\text{ V}$, $I_{N(UH, VL, WH)} = 0\text{ V}$	$V_{CC(L)} - \text{COM}$	-	-	5	mA
I_{QCCH}		$V_{CC} = 15\text{ V}$, $I_{N(UH, VH, WH)} = 0\text{ V}$	$V_{CC(H)} - \text{COM}$	-	-	150	μA
I_{PCCH}	Operating V_{CC} Supply Current	$V_{CC(UH, VH, WH)} = 15\text{ V}$ $f_{PWM} = 20\text{ kHz}$ Duty = 50%, applied to one PWM signal input for high-side	$V_{CC(UH)} - \text{COM}$ $V_{CC(VH)} - \text{COM}$ $V_{CC(WH)} - \text{COM}$	-	-	0.30	mA
I_{QCC}		$V_{CC(UH, VH, WH)} = 15\text{ V}$ $f_{PWM} = 20\text{ kHz}$ Duty = 50%, applied to one PWM signal input for low-side	$V_{CC(L)} - \text{COM}$	-	-	8.5	mA
I_{QBS}	Quiescent V_{BS} Supply Current	$V_{BS} = 15\text{ V}$, $I_{N(UH, VH, WH)} = 0\text{ V}$	$V_{B(U)} - V_{S(U)}$ $V_{B(V)} - V_{S(V)}$ $V_{B(W)} - V_{S(W)}$	-	-	150	μA
I_{PBS}	Operating V_{BS} Supply Current	$V_{CC} = V_{BC} = 15\text{ V}$ $I_{N(UH, VH, WH)} = 0\text{ V}$	$V_{B(U)} - V_{S(U)}$ $V_{B(V)} - V_{S(V)}$ $V_{B(W)} - V_{S(W)}$	-	-	4.5	mA
V_{FOH}	Fault Output Voltage	$V_{SC} = 0\text{ V}$, V_{FO} Circuit: 4.7 k Ω to 5 V Pull-up		4.5	-	-	V
V_{FOL}		$V_{SC} = 1\text{ V}$, V_{FO} Circuit: 4.7 k Ω to 5 V Pull-up		-	-	0.5	V
$V_{SC(ref)}$	Short-Circuit Trip Level	$V_{CC} = 15\text{ V}$ (Note 7)	$C_{SC} - \text{COM}$	0.45	0.52	0.59	V
UV_{CCD}	Supply Circuit Under-Voltage Protection	Detection Level, $T_J = 125^{\circ}\text{C}$		10.6	-	13.2	V
UV_{CCR}		Reset Level, $T_J = 125^{\circ}\text{C}$		11.0	-	13.8	V
UV_{BSD}		Detection Level, $T_J = 125^{\circ}\text{C}$		10.5	-	13	V
UV_{BSR}		Reset Level, $T_J = 125^{\circ}\text{C}$		10.8	-	13.3	V
t_{FOD}	Fault-out Pulse Width			-	60	-	μs
V_{TS}	LVIC Temperature Sensing Voltage Output	$V_{CC(L)} = 15\text{ V}$, $T_{LVIC} = 125^{\circ}\text{C}$ (Note 8)		-	2.4	-	V
$V_{IN(ON)}$	ON Threshold Voltage	Applied between $I_{N(UH)}$, $I_{N(VH)}$, $I_{N(WH)}$, $I_{N(UL)}$, $I_{N(VL)}$, $I_{N(WL)} - \text{COM}$		-	2.6	3.1	V
$V_{IN(OFF)}$	OFF Threshold Voltage			0.9	1.2	-	V

Product parametric performance is indicated in the Electrical Characteristics for the listed test conditions, unless otherwise noted. Product performance may not be indicated by the Electrical Characteristics if operated under different conditions.

- t_{ON} and t_{OFF} include the propagation delay time of the internal drive IC. $t_{C(ON)}$ and $t_{C(OFF)}$ are the switching times of IGBT itself under the given gate driving condition internally. Refer to Figure 6 for detailed information.
- Stray inductance L_s is sum of stray inductance of module & setup.
- Verified by design and bench-testing only.
- Short-circuit current protection is functional only for low side.
- T_{LVIC} is the junction temperature of the LVIC itself.

PACKAGE MARKING AND ORDERING INFORMATION

Part Number	Top Marking	Package	Shipping
FAM65V05DF1	FAM65V05DF1	ASPM27-CCA	10 Units/Tube

FAM65V05DF1

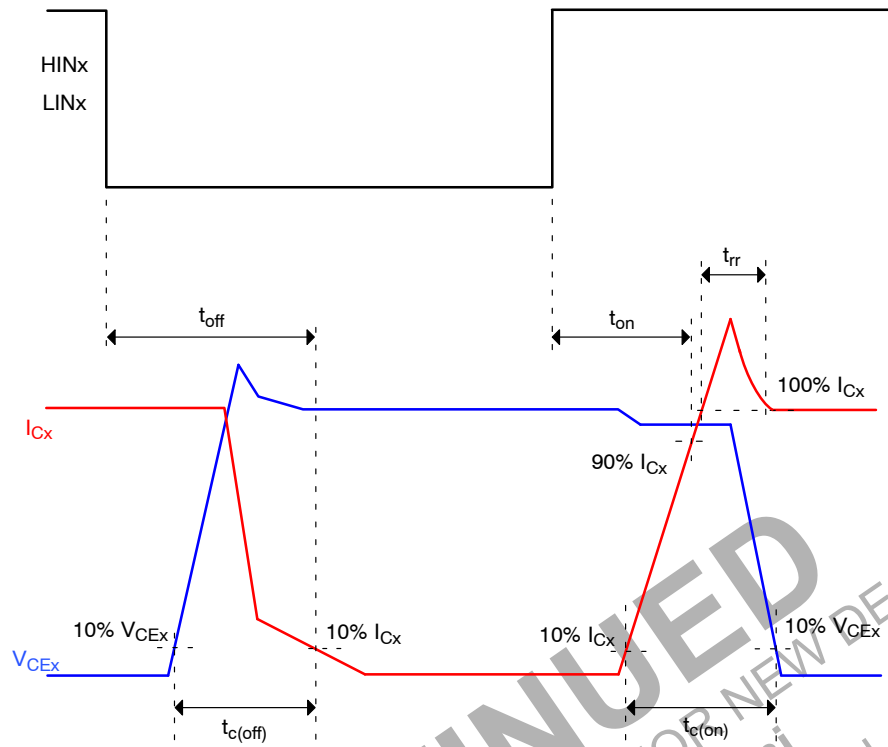

Figure 5. Switching Time Definition

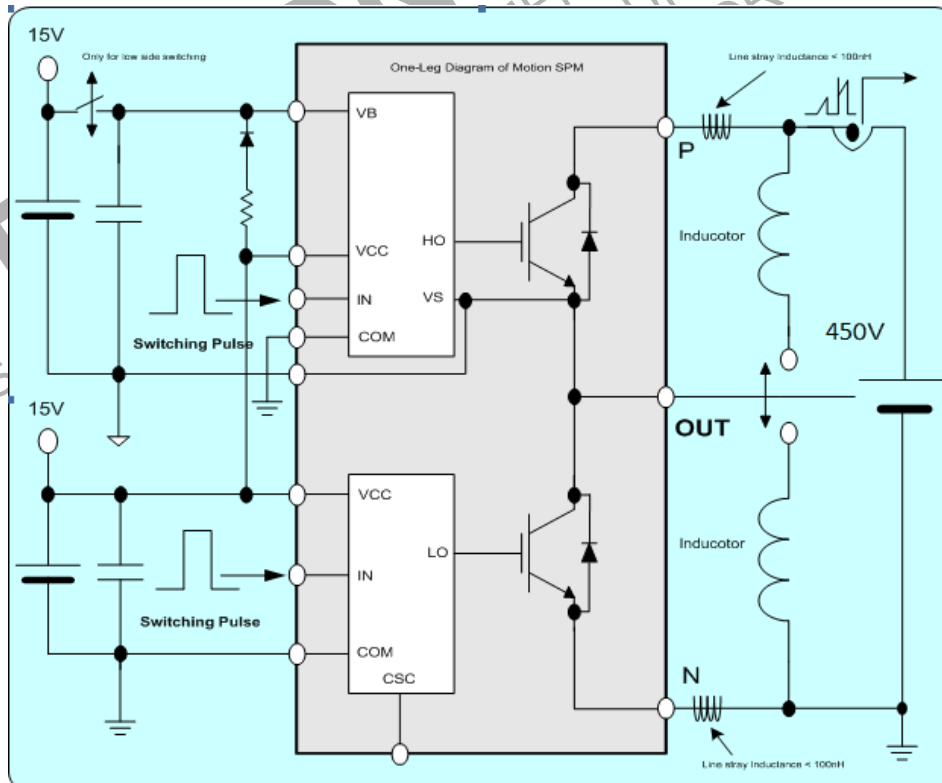

Figure 6. Switching Evaluation Circuit

FAM65V05DF1

RECOMMENDED OPERATING CONDITIONS

Symbol	Parameter	Conditions	Min	Max	Max	Unit
V_{PN}	Supply Voltage	Applied between P – N_U , N_V , N_W	–	450	500	V
V_{CC}	Control Supply Voltage	Applied between $V_{CC(H)}$, $V_{CC(L)}$ – COM	13.5	15	16.5	V
V_{BS}	High-side Bias Voltage	Applied between $V_{B(U)} - V_{S(U)}$, $V_{B(V)} - V_{S(V)}$, $V_{B(W)} - V_{S(W)}$	13.3	15	18.5	V
dV_{CC}/dt , dV_{BS}/dt	Control Supply Variation		–1	–	1	V/ μ s
t_{dead}	Blanking Time for Preventing Arm-short	For Each Input Signal	1.0	–	–	μ s
f_{PWM}	PWM Input Signal	$T_C = 125^\circ\text{C}$	–	–	20	kHz
V_{SEN}	Voltage for Current Sensing	Applied between N_U , N_V , N_W – COM (Including surge voltage)	–4	–	4	V
T_J	Junction Temperature		–40	–	150	$^\circ\text{C}$

MECHANICAL CHARACTERISTICS AND RATINGS

Parameter	Conditions	Conditions	Limits			Unit
			Min	Typ	Max	
Mounting Torque	Mounting Screw: – M3	Recommended 0.62 N·m	0.52	0.62	0.80	N·m
Device Flatness			–	–	+150	μ m
Weight				15	–	g

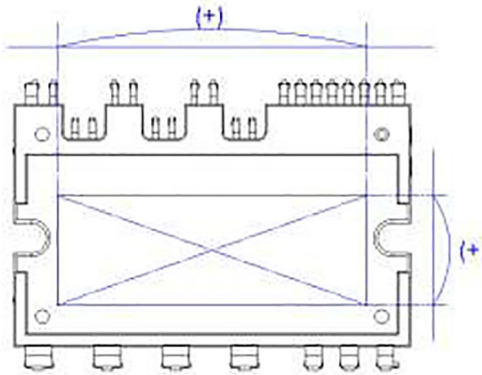

Figure 7. Flatness Measurement Position

TYPICAL INVERTER CHARACTERISTICS

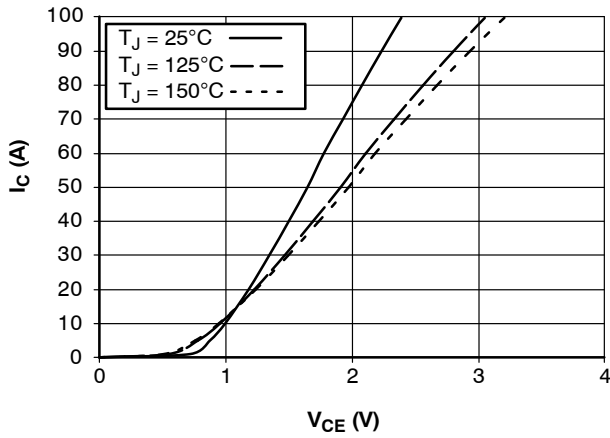

Figure 8. Output Characteristics IGBT Inverter (Typical)
 $V_{CC} = V_{BS} = 15\text{ V}$, $V_{IN} = 5\text{ V}$

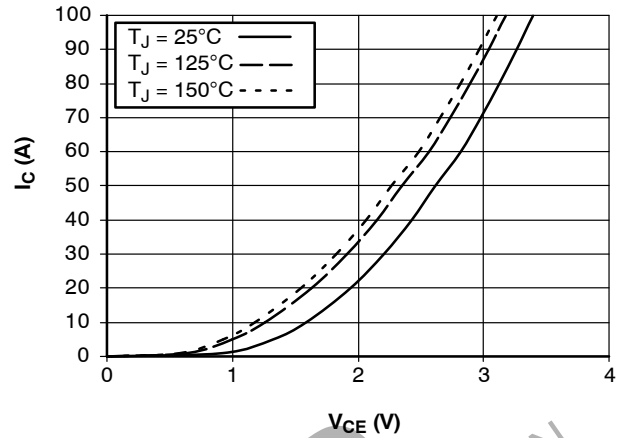

Figure 9. Forward Characteristics DIODE Inverter (Typical)
 $V_{IN} = 0\text{ V}$

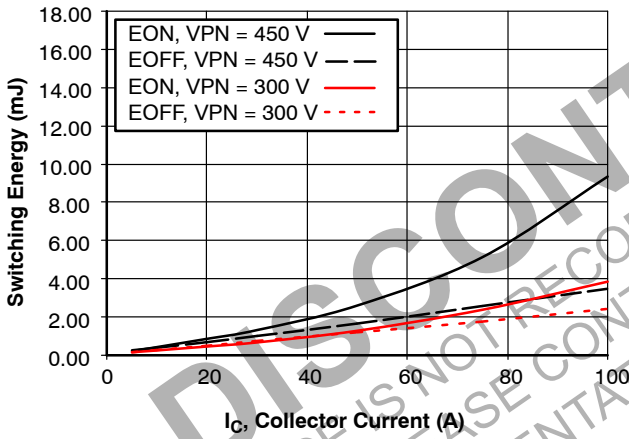

Figure 10. Switching Losses IGBT Inverter High-Side (Typical) versus Collector Current
 $V_{CC} = V_{BS} = 15\text{ V}$
 $V_{IN} = 0\text{ V} \leftrightarrow 5\text{ V}$, $L_s = 55\text{ nH}$, Inductive Load, $T_J = 125^\circ\text{C}$

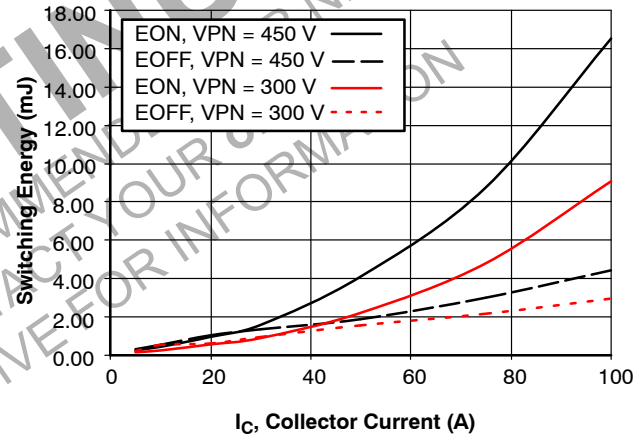

Figure 11. Switching Losses IGBT Inverter Low-Side (Typical) versus Collector Current
 $V_{CC} = V_{BS} = 15\text{ V}$
 $V_{IN} = 0\text{ V} \leftrightarrow 5\text{ V}$, $L_s = 55\text{ nH}$, Inductive Load, $T_J = 125^\circ\text{C}$

TYPICAL INVERTER CHARACTERISTICS (continued)

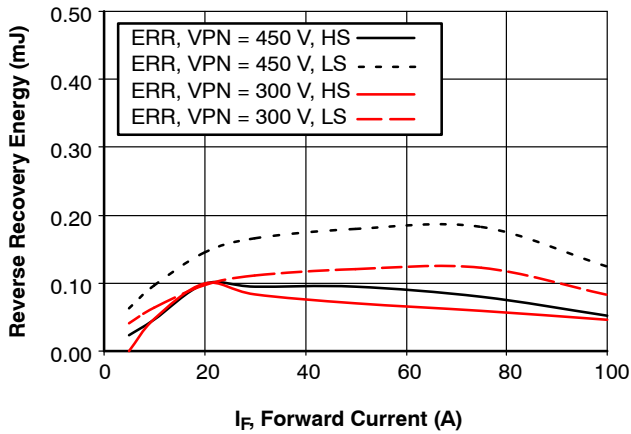

Figure 12. Reverse Recovery Energy DIODE Inverter (Typical) versus Forward Current

$V_{CC} = V_{BS} = 15\text{ V}$
 $V_{IN} = 0\text{ V} \leftrightarrow 5\text{ V}$, $L_s = 55\text{ nH}$, Inductive Load, $T_J = 125^\circ\text{C}$

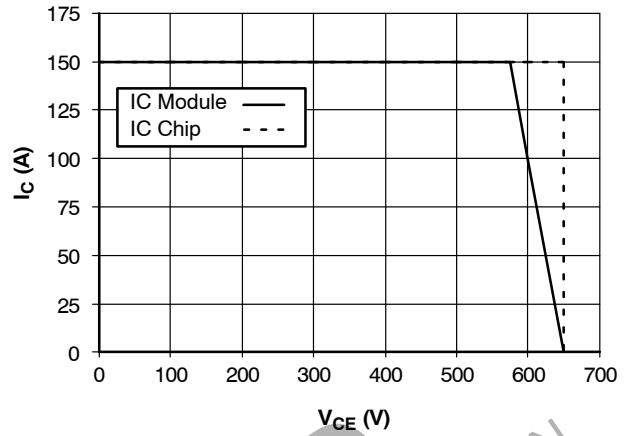

Figure 13. Reverse Bias Safe Operating Area IGBT (RBSOA) Inverter

$V_{CC} = V_{BS} = 15\text{ V}$, $T_J = 150^\circ\text{C}$

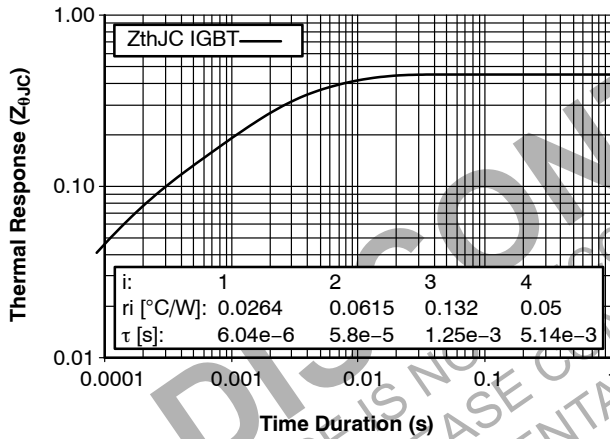

Figure 14. Transient Thermal Impedance IGBT Inverter

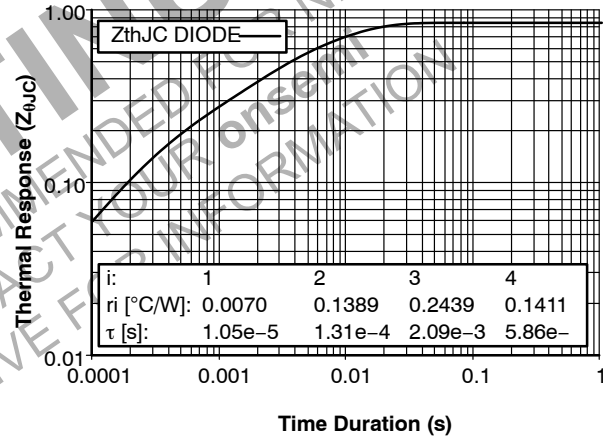

Figure 15. Transient Thermal Impedance DIODE Inverter

TYPICAL CONTROLLER CHARACTERISTICS

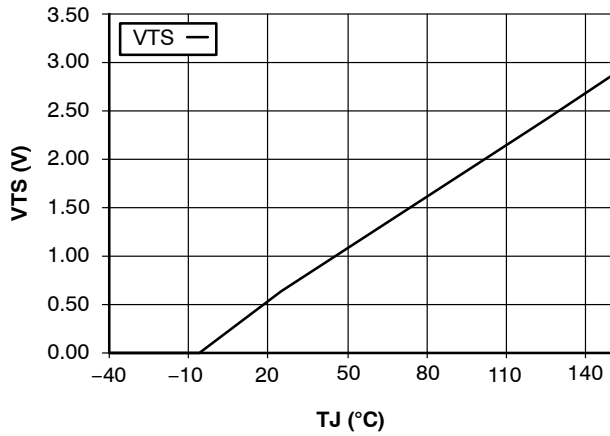

Figure 16. Temperature Profile of V_{TS} (Typical)

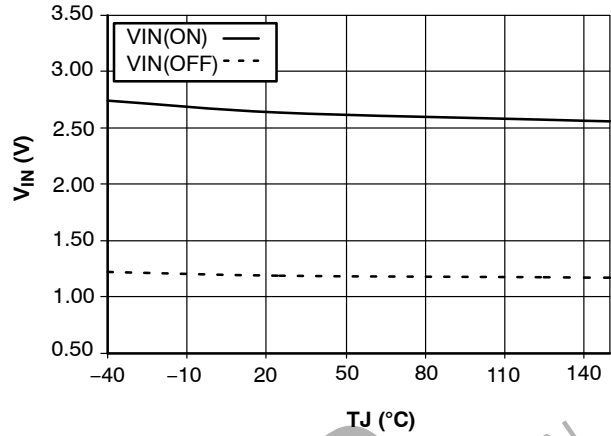

Figure 17. Threshold Voltage versus Temperature

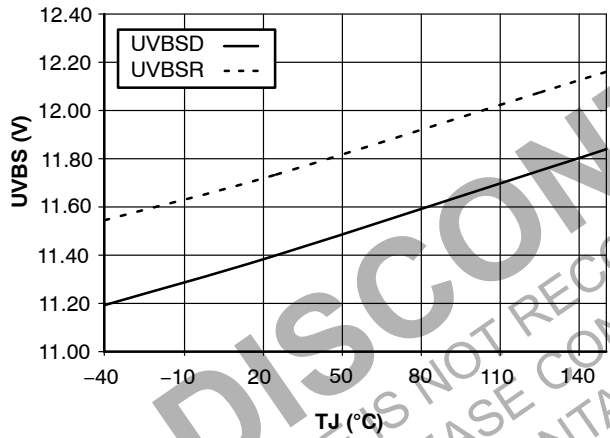

Figure 18. Supply Under-Voltage Protection High-Side (Typical)

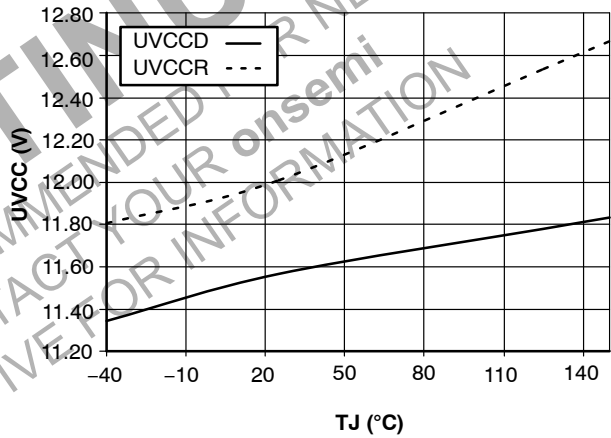
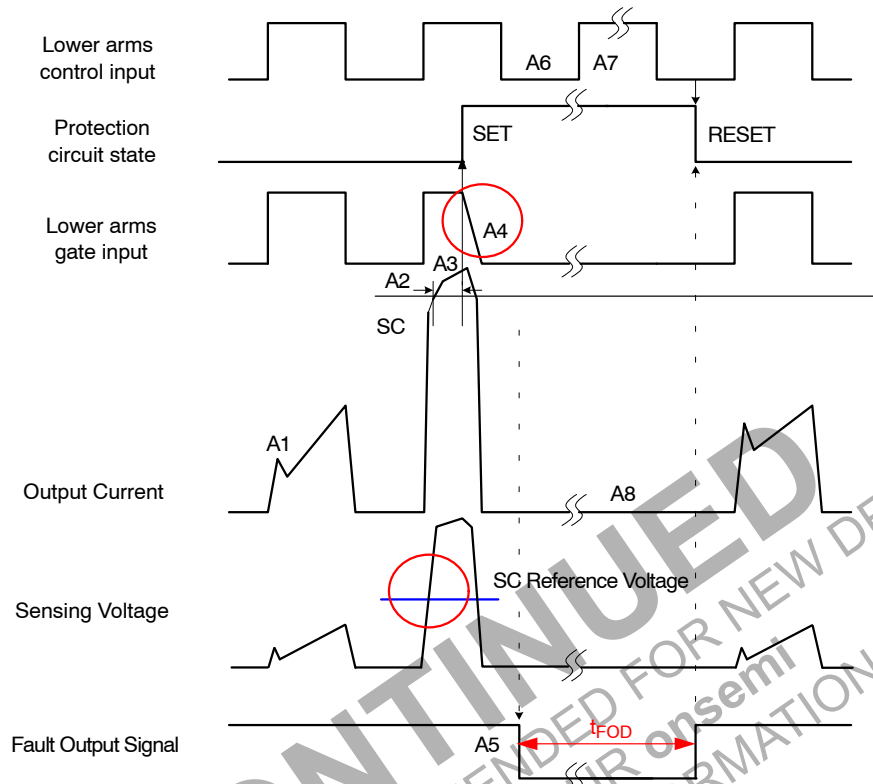

Figure 19. Supply Under-Voltage Protection Low-Side (Typical)

TIMING CHART PROTECTIVE FUNCTION



Step	Description
A1	Normal operation, IGBT on and carrying current
A2	Short-circuit current threshold reached
A3	Protection function triggered
A4	IGBT turns off with soft turn-off
A5	Fault output activated (initial delay 2 μs, t_{FOD} min. 50 μs)
A6	IGBT "LO" input
A7	IGBT "HI" input is ignored
A8	Current stays at zero during fault state

Figure 20. Short-Circuit Current Protection

FAM65V05DF1

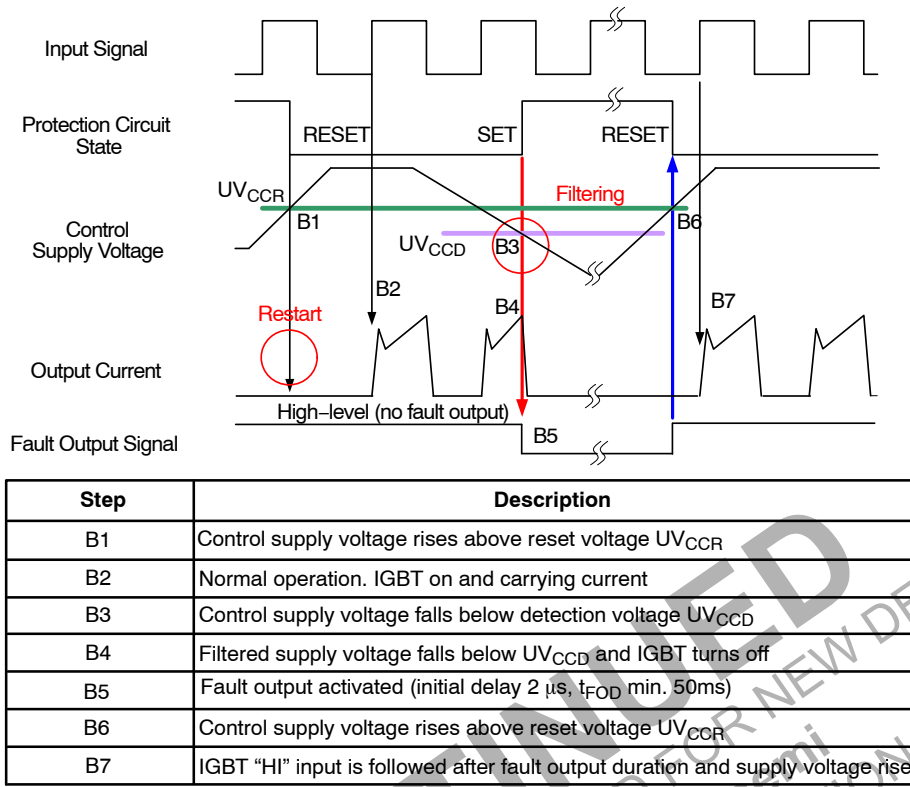
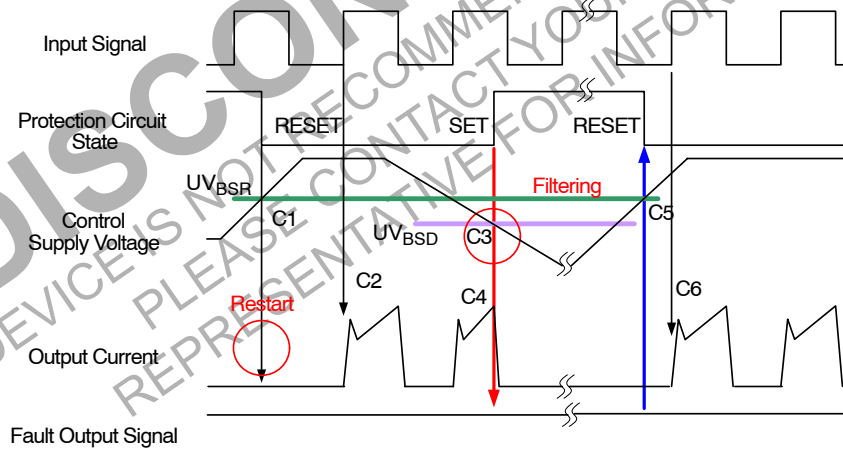

Figure 21. Under-Voltage Protection (Low-side)



Step	Description
C1	Control supply voltage rises above reset voltage UV_{CCR}
C2	Normal operation. IGBT on and carrying current
C3	Control supply voltage falls below detection voltage UV_{CCD}
C4	Filtered supply voltage falls below UV_{CCD} and IGBT turns off
C5	Control supply voltage rises above reset voltage UV_{CCR}
C6	IGBT "HI" input is followed after supply voltage rise

Figure 22. Under-Voltage Protection (High-side)

MECHANICAL CASE OUTLINE PACKAGE DIMENSIONS



27LD MODULE PDD STD CASE MODCB ISSUE A

DATE 30 JAN 2023

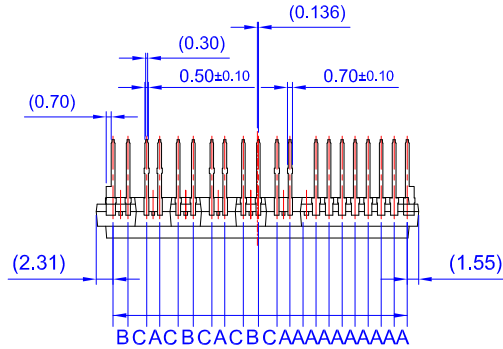

LEAD PITCH (TOLERANCE : ±0.30)

- A : 1.778
- B : 2.050
- C : 2.531

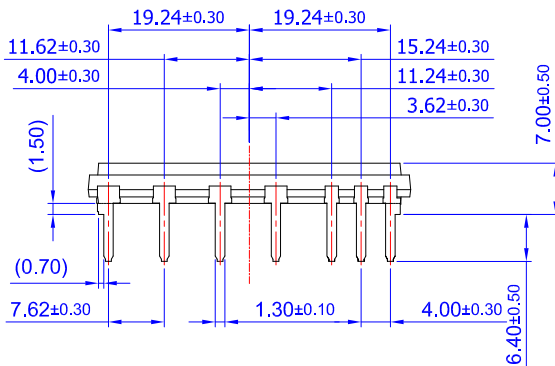
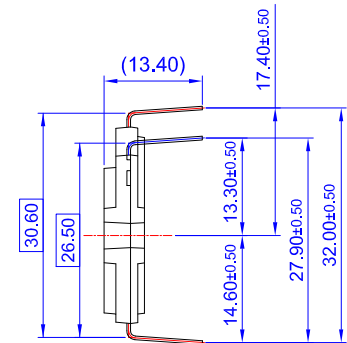
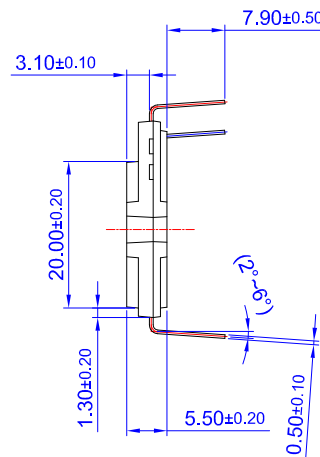
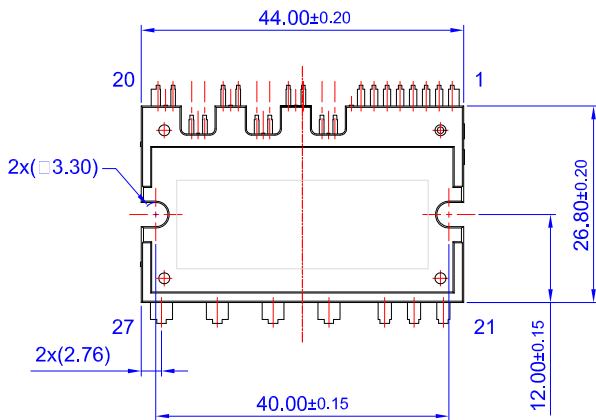

- NOTES: UNLESS OTHERWISE SPECIFIED
- A) THIS PACKAGE DOES NOT COMPLY TO ANY CURRENT PACKAGING STANDARD
 - B) ALL DIMENSIONS ARE IN MILLIMETERS.
 - C) DIMENSIONS ARE EXCLUSIVE OF BURRS, MOLD FLASH, AND TIE BAR EXTRUSIONS.
 - D) () IS REFERENCE

DOCUMENT NUMBER:	98AON13500G	Electronic versions are uncontrolled except when accessed directly from the Document Repository. Printed versions are uncontrolled except when stamped "CONTROLLED COPY" in red.
DESCRIPTION:	27LD MODULE PDD STD	PAGE 1 OF 1

onsemi and onsemi are trademarks of Semiconductor Components Industries, LLC dba onsemi or its subsidiaries in the United States and/or other countries. onsemi reserves the right to make changes without further notice to any products herein. onsemi makes no warranty, representation or guarantee regarding the suitability of its products for any particular purpose, nor does onsemi assume any liability arising out of the application or use of any product or circuit, and specifically disclaims any and all liability, including without limitation special, consequential or incidental damages. onsemi does not convey any license under its patent rights nor the rights of others.

onsemi, **Onsemi**, and other names, marks, and brands are registered and/or common law trademarks of Semiconductor Components Industries, LLC dba "**onsemi**" or its affiliates and/or subsidiaries in the United States and/or other countries. **onsemi** owns the rights to a number of patents, trademarks, copyrights, trade secrets, and other intellectual property. A listing of **onsemi**'s product/patent coverage may be accessed at www.onsemi.com/site/pdf/Patent-Marking.pdf. **onsemi** reserves the right to make changes at any time to any products or information herein, without notice. The information herein is provided "as-is" and **onsemi** makes no warranty, representation or guarantee regarding the accuracy of the information, product features, availability, functionality, or suitability of its products for any particular purpose, nor does **onsemi** assume any liability arising out of the application or use of any product or circuit, and specifically disclaims any and all liability, including without limitation special, consequential or incidental damages. Buyer is responsible for its products and applications using **onsemi** products, including compliance with all laws, regulations and safety requirements or standards, regardless of any support or applications information provided by **onsemi**. "Typical" parameters which may be provided in **onsemi** data sheets and/or specifications can and do vary in different applications and actual performance may vary over time. All operating parameters, including "Typicals" must be validated for each customer application by customer's technical experts. **onsemi** does not convey any license under any of its intellectual property rights nor the rights of others. **onsemi** products are not designed, intended, or authorized for use as a critical component in life support systems or any FDA Class 3 medical devices or medical devices with a same or similar classification in a foreign jurisdiction or any devices intended for implantation in the human body. Should Buyer purchase or use **onsemi** products for any such unintended or unauthorized application, Buyer shall indemnify and hold **onsemi** and its officers, employees, subsidiaries, affiliates, and distributors harmless against all claims, costs, damages, and expenses, and reasonable attorney fees arising out of, directly or indirectly, any claim of personal injury or death associated with such unintended or unauthorized use, even if such claim alleges that **onsemi** was negligent regarding the design or manufacture of the part. **onsemi** is an Equal Opportunity/Affirmative Action Employer. This literature is subject to all applicable copyright laws and is not for resale in any manner.

ADDITIONAL INFORMATION

TECHNICAL PUBLICATIONS:

Technical Library: www.onsemi.com/design/resources/technical-documentation
onsemi Website: www.onsemi.com

ONLINE SUPPORT: www.onsemi.com/support

For additional information, please contact your local Sales Representative at www.onsemi.com/support/sales

Looking for pricing, stock, or lifecycle information?

Click below to explore more details on WIN SOURCE:

 [View FAM65V05DF1](#) on WIN SOURCE

 [ON Semiconductor](#) Information

Optimize Your Supply Chain with WIN SOURCE Solutions

-  Global Sourcing Solution
-  Obsolete Management
-  Cost Control Management
-  Shortage Management
-  Alternative Solution
-  Excess Inventory Management