



**THE DATASHEET OF
AD7294-2BSUZ**





12-Bit Monitor and Control System with Multichannel ADC, DACs, Temperature Sensor, and Current Sense

Data Sheet

AD7294-2

FEATURES

- 12-bit SAR ADC with 3 μ s conversion time
 - 4 uncommitted analog inputs
 - Differential/single-ended
 - V_{REF} , $2 \times V_{REF}$ input ranges
- 2 high-side current sense inputs
 - 5 V to 59.4 V operating range
 - 0.75% maximum gain error
 - ± 200 mV input range
- 2 external diode temperature sensor inputs
 - -55°C to $+150^{\circ}\text{C}$ measurement range
 - $\pm 2^{\circ}\text{C}$ accuracy
 - Series resistance cancellation
- 1 internal temperature sensor: $\pm 2^{\circ}\text{C}$ accuracy
- Built-in monitoring features
 - Minimum/maximum recorder for each channel
 - Programmable alert thresholds
 - Programmable hysteresis
- Four 12-bit, monotonic, 15 V DACs
 - 5 V span, 0 V to 10 V offset
 - 8 μ s settling time
 - 10 mA sink and source capability
 - Power-on reset (POR) to 0 V
- Internal 2.5 V reference
- 2-wire, fast mode I²C interface
- Temperature range: -40°C to $+105^{\circ}\text{C}$
- Package type: 64-lead TQFP
- Pin compatible with the [AD7294](#)

APPLICATIONS

- Cellular base stations
 - GSM, EDGE, UMTS, CDMA, TD-SCDMA, W-CDMA, WiMAX
- Point-to-multipoint and other RF transmission systems
- 12 V, 24 V, 48 V automotive applications
- Industrial controls

GENERAL DESCRIPTION

The [AD7294-2](#) contains all the functions that are required for general-purpose monitoring and control of current, voltage, and temperature, integrated into a single-chip solution. The part includes low voltage (± 200 mV) analog input sense amplifiers for current monitoring across shunt resistors, temperature sense inputs, and four uncommitted analog input channels multiplexed into a SAR analog-to-digital converter (ADC) with a 3 μ s conversion time. A high accuracy internal reference is provided to drive both the digital-to-analog converters (DACs) and the ADC. Four 12-bit DACs provide the outputs for voltage control. The [AD7294-2](#) also includes limit registers for alarm functions. The part is designed for high voltage compliance: 59.4 V on the current sense inputs and up to a 15 V DAC output voltage.

The [AD7294-2](#) is a highly integrated solution that offers all the functionality necessary for precise control of the power amplifier in cellular base station applications. In these types of applications, the DACs provide 12-bit resolution to control the bias currents of the power transistors. Thermal diode-based temperature sensors are incorporated to compensate for temperature effects. The ADC monitors the high-side current and temperature. This functionality is provided in a 64-lead TQFP, which operates over a temperature range of -40°C to $+105^{\circ}\text{C}$.

Rev. 0

[Document Feedback](#)

Information furnished by Analog Devices is believed to be accurate and reliable. However, no responsibility is assumed by Analog Devices for its use, nor for any infringements of patents or other rights of third parties that may result from its use. Specifications subject to change without notice. No license is granted by implication or otherwise under any patent or patent rights of Analog Devices. Trademarks and registered trademarks are the property of their respective owners.

One Technology Way, P.O. Box 9106, Norwood, MA 02062-9106, U.S.A.
Tel: 781.329.4700 ©2013 Analog Devices, Inc. All rights reserved.
[Technical Support](#) www.analog.com

TABLE OF CONTENTS

Features	1	Command Register	26
Applications	1	ADC Result Register	26
General Description	1	T _{SENSE1} and T _{SENSE2} Result Registers	27
Revision History	2	T _{SENSEINT} Result Register	27
Functional Block Diagram	3	DAC _A , DAC _B , DAC _C , and DAC _D Value Registers.....	27
Specifications.....	4	Alert Status Register A, Alert Status Register B, and Alert Status Register C.....	28
DAC Specifications.....	4	Channel Sequence Register.....	28
ADC Specifications	5	Configuration Register	29
General Specifications	7	Power-Down Register.....	30
Timing Characteristics	8	DATA _{LOW} and DATA _{HIGH} Registers	30
Absolute Maximum Ratings.....	9	Hysteresis Registers.....	30
Thermal Resistance	9	Remote Channel T _{SENSE1} and T _{SENSE2} Offset Registers.....	31
ESD Caution.....	9	I ² C Interface	32
Pin Configuration and Function Descriptions.....	10	General I ² C Timing.....	32
Typical Performance Characteristics	12	Serial Bus Address Byte	32
Terminology	17	Interface Protocol	33
DAC Terminology	17	Modes of Operation	36
ADC Terminology.....	17	Command Mode	36
Theory of Operation	18	Autocycle Mode.....	37
ADC Overview	18	Alerts and Limits Theory	38
ADC Transfer Functions	18	ALERT_FLAG Bit	38
Analog Inputs.....	19	Alert Status Registers	38
Current Sensor.....	20	DATA _{LOW} and DATA _{HIGH} Monitoring Features	38
Analog Comparator Loop	22	Hysteresis.....	39
Temperature Sensor	22	Applications Information	40
DAC Operation.....	23	Base Station Power Amplifier Monitor and Control.....	40
ADC and DAC Reference.....	24	Gain Control of Power Amplifier.....	41
V _{DRIVE} Feature	24	Outline Dimensions	42
Register Settings.....	25	Ordering Guide	42
Address Pointer Register	25		

REVISION HISTORY

6/13—Revision 0: Initial Version

FUNCTIONAL BLOCK DIAGRAM

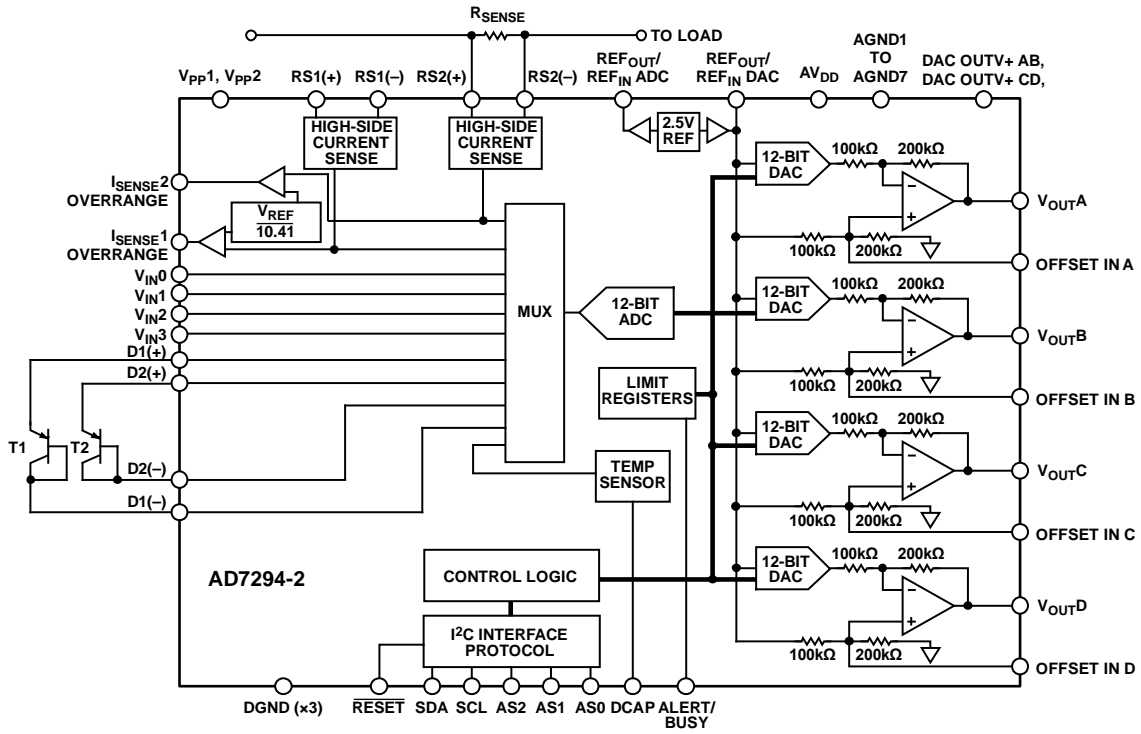

Figure 1.

109396-001

SPECIFICATIONS

DAC SPECIFICATIONS

$AV_{DD} = 4.5\text{ V to }5.5\text{ V}$, $AGND1\text{ to }AGND7 = DGND = 0\text{ V}$, internal 2.5 V reference; $V_{DRIVE} = 2.7\text{ V to }5.5\text{ V}$; $T_A = -40^\circ\text{C to }+105^\circ\text{C}$, unless otherwise noted. $DAC\text{ OUTV+ AB and }DAC\text{ OUTV+ CD} = 4.5\text{ V to }16.5\text{ V}$; $OFFSET\text{ IN }x$ is floating; therefore, the DAC output span = $0\text{ V to }5\text{ V}$.

Table 1.

Parameter	Min	Typ	Max	Unit	Test Conditions/Comments
ACCURACY¹					
Resolution	12			Bits	
Relative Accuracy (INL)		± 1	± 3	LSB	
Differential Nonlinearity (DNL)		± 0.3	± 1	LSB	Guaranteed monotonic
Zero-Code Error		2.5	6	mV	
Full-Scale Error			10	mV	$DAC\text{ OUTV+} = 5.5\text{ V}$
Offset Error			± 4	mV	Measured in the linear region, $T_A = -40^\circ\text{C to }+105^\circ\text{C}$
			± 2	mV	Measured in the linear region, $T_A = 25^\circ\text{C}$
Offset Error Temperature Coefficient		± 5		ppm/ $^\circ\text{C}$	
Gain Error		± 0.025	± 0.155	% FSR	
Gain Error Drift		± 5		ppm/ $^\circ\text{C}$	
DAC OUTPUT CHARACTERISTICS					
Output Voltage Span	0		$2 \times V_{REF}$	V	0 V to 5 V for a 2.5 V reference
Output Voltage Offset	0		10	V	The output voltage span can be positioned in the 0 V to 15 V range; if the $OFFSET\text{ IN }x$ pin is left floating, the offset = $2/3 \times V_{REF}$, giving an output of 0 V to $2 \times V_{REF}$
Offset Input Pin Range	0		5	V	$V_{OUT} = 3 \times V_{OFFSET} - 2 \times V_{REF} + V_{DAC}$
DC Input Impedance ²		75		k Ω	100 k Ω to V_{REF} , and 200 k Ω to AGND; see Figure 45
Output Voltage Settling Time ²		8		μs	1/4 to 3/4 change within 1/2 LSB, measured from last SCL edge
Slew Rate ²		1.1		V/ μs	
Short-Circuit Current ²		40		mA	Full-scale current shorted to ground
Load Current ²		± 10		mA	Source and/or sink within 200 mV of supply
Capacitive Load Stability ²	10			nF	$R_L = \infty$
DC Output Impedance ²		1		Ω	
REFERENCE					
Reference Output Voltage	2.49	2.5	2.51	V	$\pm 0.2\%$ maximum at 25°C , $AV_{DD} = 5\text{ V}$
Reference Input Voltage Range	0		$AV_{DD} - 2$	V	
Input Current		400	480	μA	$V_{REF} = 2.5\text{ V}$
Input Capacitance ²		20		pF	
V_{REF} Output Impedance ²		5		Ω	A buffer is required if the reference output is used to drive external loads
Reference Temperature Coefficient		10	25	ppm/ $^\circ\text{C}$	

¹ Linearity calculated using a reduced code range: Code 10 to Code 4095.

² Guaranteed by design and characterization; not production tested.

ADC SPECIFICATIONS

$V_{DD} = 4.5\text{ V to }5.5\text{ V}$, $AGND1\text{ to }AGND7 = DGND = 0\text{ V}$, internal or external 2.5 V reference; $V_{DRIVE} = 2.7\text{ V to }5.5\text{ V}$; $V_{PPX} = AV_{DD}\text{ to }59.4\text{ V}$; $T_A = -40^\circ\text{C to }+105^\circ\text{C}$, unless otherwise noted.

Table 2.

Parameter	Min	Typ	Max	Unit	Test Conditions/Comments
DC ACCURACY					
Resolution		12		Bits	
Integral Nonlinearity (INL) ¹		±0.5	±1	LSB	Differential mode
		±0.5	±1.5	LSB	Single-ended or pseudo differential mode
Differential Nonlinearity (DNL) ¹		±0.5	±0.99	LSB	Differential, single-ended, and pseudo differential modes
Single-Ended Mode					
Offset Error		±1	±7	LSB	
Offset Error Match		±0.4		LSB	
Gain Error		±0.5	±4.5	LSB	
Gain Error Match		±0.4		LSB	
Differential Mode					
Positive Gain Error		±1		LSB	
Positive Gain Error Match		±0.5		LSB	
Zero Code Error		±3		LSB	
Zero Code Error Match		±0.5		LSB	
Negative Gain Error		±1		LSB	
Negative Gain Error Match		±0.5		LSB	
CONVERSION RATE					
Conversion Time ²		3		µs	
Autocycle Update Rate ²		50		µs	
Throughput Rate			22.22	kSPS	$f_{SCL} = 400\text{ kHz}$
ANALOG INPUT³					
Single-Ended Input Range	0		V_{REF}	V	0 V to V_{REF} mode
	0		$2 \times V_{REF}$	V	0 V to $2 \times V_{REF}$ mode
Pseudo Differential Input Range: $V_{IN+} - V_{IN-}$ ⁴	0		V_{REF}	V	0 V to V_{REF} mode
	0		$2 \times V_{REF}$	V	0 V to $2 \times V_{REF}$ mode
Fully Differential Input Range: $V_{IN+} - V_{IN-}$	$-V_{REF}$		$+V_{REF}$	V	0 V to V_{REF} mode
	$-2 \times V_{REF}$		$+2 \times V_{REF}$	V	0 V to $2 \times V_{REF}$ mode
Input Capacitance ²		30		pF	
DC Input Leakage Current			±1	µA	
DYNAMIC PERFORMANCE					
Signal-to-Noise Ratio (SNR) ¹		73		dB	$f_{IN} = 10\text{ kHz}$ sine wave; differential mode
		72		dB	$f_{IN} = 10\text{ kHz}$ sine wave; single-ended and pseudo differential modes
Signal-to-Noise and Distortion Ratio (SINAD) ¹		72.5		dB	$f_{IN} = 10\text{ kHz}$ sine wave; differential mode
		71.5		dB	$f_{IN} = 10\text{ kHz}$ sine wave; single-ended and pseudo differential modes
Total Harmonic Distortion (THD) ¹		-81		dB	$f_{IN} = 10\text{ kHz}$ sine wave; differential mode
		-79		dB	$f_{IN} = 10\text{ kHz}$ sine wave; single-ended and pseudo differential modes
Spurious-Free Dynamic Range (SFDR) ¹		-81		dB	$f_{IN} = 10\text{ kHz}$ sine wave; differential mode
		-79		dB	$f_{IN} = 10\text{ kHz}$ sine wave; single-ended and pseudo differential modes
Channel-to-Channel Isolation ²		-90		dB	$f_{IN} = 0.5\text{ Hz to }100\text{ kHz}$

Parameter	Min	Typ	Max	Unit	Test Conditions/Comments
TEMPERATURE SENSOR—INTERNAL					
Operating Range	-40		+105	°C	Internal temperature sensor, $T_A = -30^\circ\text{C}$ to $+90^\circ\text{C}$ Internal temperature sensor, $T_A = -40^\circ\text{C}$ to $+105^\circ\text{C}$ LSB size
Accuracy			± 2	°C	
			± 2.5	°C	
Resolution		0.25		°C	
Update Rate		5		ms	
TEMPERATURE SENSOR—EXTERNAL					
Operating Range	-55		+150	°C	External transistor is 2N3906 Limited by external diode $T_A = T_{\text{DIODE}} = -40^\circ\text{C}$ to $+105^\circ\text{C}$ LSB size
Accuracy			± 2	°C	
Resolution		0.25		°C	
Low Level Output Current Source ²		8		μA	
Medium Level Output Current Source ²		32		μA	
High Level Output Current Source ²		128		μA	
Maximum Series Resistance (R_S) for External Diode ²			10	k Ω	
Maximum Parallel Capacitance (C_P) for External Diode ²			1	nF	$R_S = 0$ (see Figure 28)
CURRENT SENSE					
V_{PP} Supply Range	AV_{DD}		59.4	V	$V_{PP} = AV_{DD}$ to 59.4 V
Gain Error			± 0.75	% FSR	2.5 V reference
Differential Input		± 200		mV	2.5 V reference
RS(+)/RS(-) Input Bias Current		25	32	μA	Inputs shorted to V_{PP}
CMRR/PSRR ²		110		dB	
Offset Error		± 50	± 780	μV	
Offset Drift		3		$\mu\text{V}/^\circ\text{C}$	Referred to input Per channel, $V_{PP1} = V_{PP2} = 59.4$ V
Amplifier Peak-to-Peak Noise ²		400		μV	
V_{PP} Supply Current		0.18	0.25	mA	
REFERENCE					
Reference Output Voltage	2.49	2.5	2.51	V	$\pm 0.2\%$ maximum at 25°C
Reference Input Voltage Range ²	0.1		4.1	V	A buffer is required if the reference output is used to drive external loads
DC Leakage Current			± 2	μA	
V_{REF} Output Impedance ²		5		Ω	
Input Capacitance ²		20		pF	
Reference Temperature Coefficient		10	25	ppm/ $^\circ\text{C}$	

¹ See the Terminology section for more information.

² Guaranteed by design and characterization; not production tested.

³ V_{IN+} and V_{IN-} must remain within AGND/ AV_{DD} . (The analog input pins are V_{IN3} to V_{IN0} .)

⁴ $V_{IN-} = 0$ V for specified performance. For full input range on V_{IN-} , see Figure 36.

GENERAL SPECIFICATIONS

$AV_{DD} = 4.5\text{ V to }5.5\text{ V}$, $AGND1\text{ to }AGND7 = DGND = 0\text{ V}$, internal or external 2.5 V reference; $V_{DRIVE} = 2.7\text{ V to }5.5\text{ V}$; $V_{PPX} = AV_{DD}$ to 59.4 V ; $DAC\text{ OUTV+ AB and }DAC\text{ OUTV+ CD} = 4.5\text{ V to }16.5\text{ V}$; $OFFSET\text{ IN }x$ is floating; therefore, $DAC\text{ output span} = 0\text{ V to }5\text{ V}$; $T_A = -40^\circ\text{C to }+105^\circ\text{C}$, unless otherwise noted.

Table 3.

Parameter	Symbol	Min	Typ	Max	Unit	Test Conditions/Comments
LOGIC INPUTS						
Input High Voltage	V_{IH}	$0.7 V_{DRIVE}$			V	SDA, SCL only
Input Low Voltage	V_{IL}			$0.3 V_{DRIVE}$	V	SDA, SCL only
Input Leakage Current	I_{IN}			± 1	μA	
Input Hysteresis ¹	V_{HYST}	$0.05 V_{DRIVE}$			V	
Input Capacitance ¹	C_{IN}		8		pF	
Glitch Rejection ¹			50		ns	Input filtering suppresses noise spikes of less than 50 ns
Maximum External Capacitance of I ² C Address Pins When Floating ¹				30	pF	Tristate input
LOGIC OUTPUTS						
SDA, ALERT						
Output Low Voltage	V_{OL}			0.4	V	SDA and ALERT/BUSY are open-drain outputs
Floating-State Leakage Current ¹				0.6	V	$I_{SINK} = 3\text{ mA}$
Floating-State Output Capacitance ¹			8	± 1	μA	$I_{SINK} = 6\text{ mA}$
I_{SENSE} OVERRANGE						
Output High Voltage	V_{OH}			$V_{DRIVE} - 0.2$	V	$I_{SENSEX}\text{ OVERRANGE}$ are push-pull outputs
Output Low Voltage	V_{OL}			0.2	V	$I_{SOURCE} = 200\text{ }\mu\text{A}$ for push-pull outputs
Overrange Setpoint ¹		V_{FS}	$V_{FS} \times 1.2$		mV	$I_{SINK} = 200\text{ }\mu\text{A}$ for push-pull outputs $V_{FS} = \pm V_{REF}\text{ ADC}/12.5$
POWER REQUIREMENTS						
V_{PP1}, V_{PP2}		AV_{DD}		59.4	V	
AV_{DD}		4.5		5.5	V	
$DAC\text{ OUTV+ }xx$		4.5		16.5	V	
V_{DRIVE}		2.7		5.5	V	
I_{DD}			5.3	7.5	mA	$AV_{DD} + V_{DRIVE}$; DAC outputs unloaded
$DAC\text{ OUTV+ }xx, I_{DD}$			0.6	1.2	mA	At midscale output voltage, DAC outputs unloaded
Power Dissipation			70	110	mW	
Power-Down						
I_{DD}			4.4	5.5	mA	AV_{DD} and V_{DRIVE} ; ADC, DACs, and temperature sensor powered down
$DAC\text{ OUTV+ }x, I_{DD}$			35	60	μA	
Power Dissipation				70	mW	

¹ Guaranteed by design and characterization; not production tested.

TIMING CHARACTERISTICS

I²C Serial Interface

AV_{DD} = 4.5 V to 5.5 V, AGND1 to AGND7 = DGND = 0 V, internal or external 2.5 V reference; V_{DRIVE} = 2.7 V to 5.5 V; V_{PPX} = AV_{DD} to 59.4 V; DAC OUTV+ AB and DAC OUTV+ CD = 4.5 V to 16.5 V; OFFSET IN x is floating, therefore, DAC output span = 0 V to 5 V; T_A = -40°C to +105°C, unless otherwise noted.

Table 4.

Parameter ¹	Limit at T _{MIN} , T _{MAX}	Unit	Symbol	Description
f _{SCL}	400	kHz max		SCL clock frequency
t ₁	2.5	μs min		SCL cycle time
t ₂	0.6	μs min	t _{HIGH}	SCL high time
t ₃	1.3	μs min	t _{LOW}	SCL low time
t ₄	0.6	μs min	t _{HD,STA}	Start/repeated start condition hold time
t ₅	100	ns min	t _{SU,DAT}	Data setup time
t ₆	0.9	μs max	t _{HD,DAT}	Data hold time
	0	μs min	t _{HD,DAT}	Data hold time
t ₇	0.6	μs min	t _{SU,STA}	Setup time for repeated start
t ₈	0.6	μs min	t _{SU,STO}	Stop condition setup time
t ₉	1.3	μs min	t _{BUF}	Bus free time between a stop and a start condition
t ₁₀ ²	300	ns max	t _R	Rise time of SCL and SDA when receiving
	0	ns min	t _R	Rise time of SCL and SDA when receiving (CMOS compatible)
t ₁₁ ²	300	ns max	t _F	Fall time of SDA when transmitting
	20 × (V _{DRIVE} /5.5 V)	ns min	t _F	Fall time of SCL and SDA when transmitting
	0	ns min	t _F	Fall time of SDA when receiving (CMOS compatible)
	300	ns max	t _F	Fall time of SCL and SDA when receiving
C _b ³	400	pF max		Capacitive load for each bus line

¹ See Figure 2.

² t_R and t_F are measured between 0.3 V_{DD} and 0.7 V_{DD}.

³ C_b is the total capacitance in pF of one bus line.

Timing and Circuit Diagrams

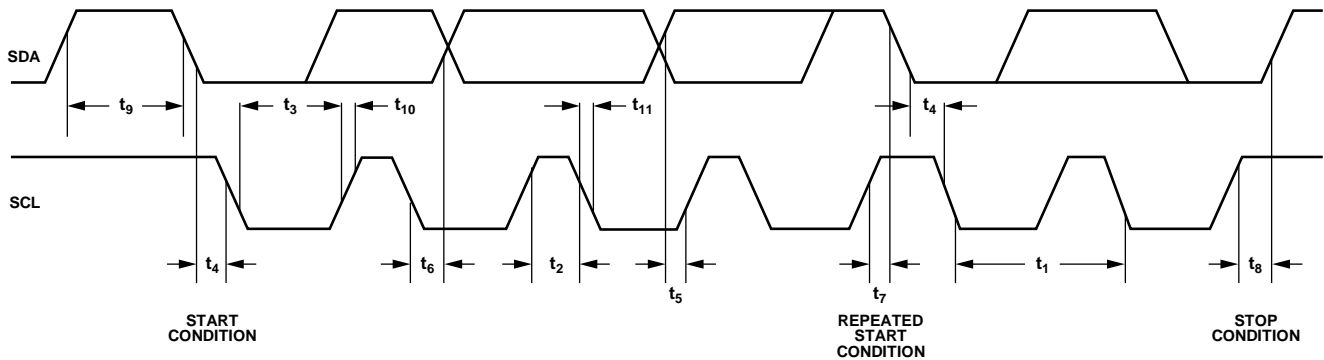

Figure 2. I²C-Compatible Serial Interface Timing Diagram

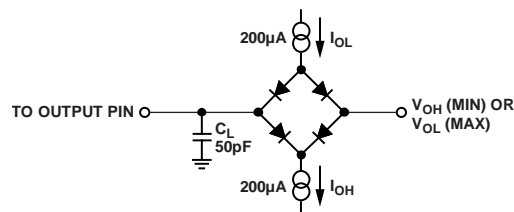

Figure 3. Load Circuit for Digital Output

ABSOLUTE MAXIMUM RATINGS

$T_A = 25^\circ\text{C}$, unless otherwise noted.¹

Table 5.

Parameter	Rating
V_{PPX} to AGND	-0.3 V to +65 V
AV_{DD} to AGND	-0.3 V to +7 V
DAC OUTV+ AB to AGND	-0.3 V to +17 V
DAC OUTV+ CD to AGND	-0.3 V to +17 V
V_{DRIVE} to OPGND	-0.3 V to +7 V
Digital Inputs to OPGND	-0.3 V to $V_{DRIVE} + 0.3$ V
RESET to OPGND	-0.3 V to +7 V
SDA/SCL to OPGND	-0.3 V to +7 V
Digital Outputs to OPGND	-0.3 V to $V_{DRIVE} + 0.3$ V
RS(+)/RS(-) to V_{PPX}	$V_{PPX} - 0.3$ V to $V_{PPX} + 0.3$ V
REF _{OUT} /REF _{IN} ADC to AGND	-0.3 V to $AV_{DD} + 0.3$ V
REF _{OUT} /REF _{IN} DAC to AGND	-0.3 V to $AV_{DD} + 0.3$ V
OPGND to AGND	-0.3 V to +0.3 V
OPGND to DGND	-0.3 V to +0.3 V
AGND to DGND	-0.3 V to +0.3 V
V_{OUTX} to AGND	-0.3 V to DAC OUTV+ xx + 0.3 V
Analog Inputs to AGND	-0.3 V to $AV_{DD} + 0.3$ V
Operating Temperature Range	-40°C to +105°C
Storage Temperature Range	-65°C to +150°C
Junction Temperature ($T_{J\text{ MAX}}$)	150°C
ESD, Human Body Model	1 kV
Reflow Soldering Peak Temperature	260°C

¹ Transient currents of up to 100 mA do not cause SCR latch-up.

Stresses above those listed under Absolute Maximum Ratings may cause permanent damage to the device. This is a stress rating only; functional operation of the device at these or any other conditions above those indicated in the operational section of this specification is not implied. Exposure to absolute maximum rating conditions for extended periods may affect device reliability.

To conform with IPC-2221 industrial standards, it is advisable to use conformal coating on the high voltage pins.

THERMAL RESISTANCE

Table 6. Thermal Resistance

Package Type	θ_{JA}	θ_{JC}	Unit
64-Lead TQFP	54	16	°C/W

ESD CAUTION



ESD (electrostatic discharge) sensitive device.

Charged devices and circuit boards can discharge without detection. Although this product features patented or proprietary protection circuitry, damage may occur on devices subjected to high energy ESD. Therefore, proper ESD precautions should be taken to avoid performance degradation or loss of functionality.

PIN CONFIGURATION AND FUNCTION DESCRIPTIONS

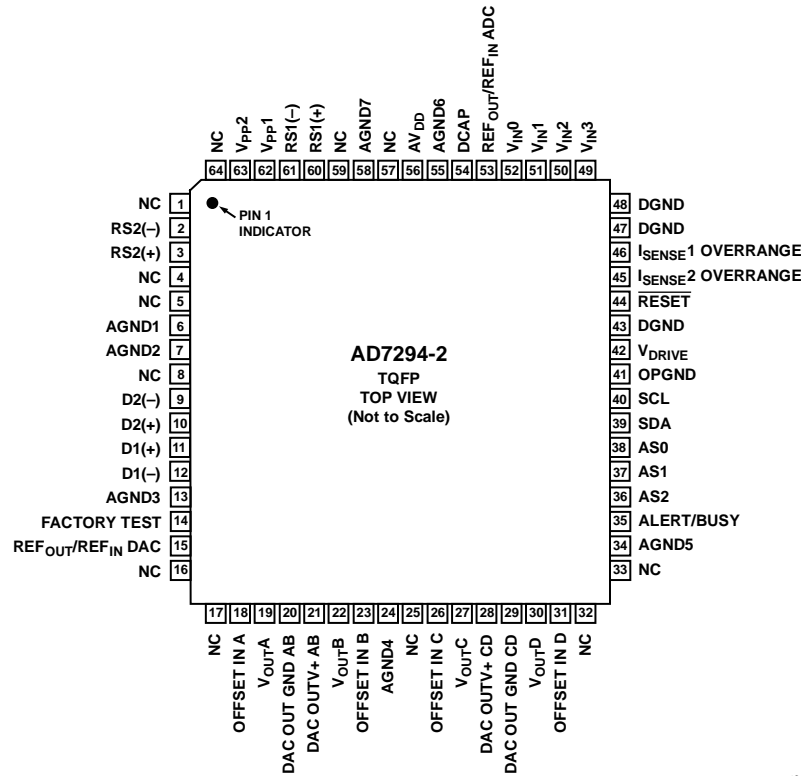

NOTES
 1. NC = NO INTERNAL CONNECTION.

Figure 4. Pin Configuration

Table 7. Pin Function Descriptions

Pin No.	Mnemonic	Description
2, 61	RS2(-), RS1(-)	Connection for External Shunt Resistor.
3, 60	RS2(+), RS1(+)	Connection for External Shunt Resistor.
1, 4, 5, 8, 16, 17, 25, 32, 33, 57, 59, 64	NC	This pin has no internal connection.
14	FACTORY TEST	Factory Test Pin. To maintain pin compatibility with the AD7294, this pin can tolerate being connected to voltages of up to 5.5 V.
56	AV _{DD}	Analog Supply Pin. The operating range is 4.5 V to 5.5 V. This pin provides the supply voltage for all the analog circuitry on the AD7294-2. This supply should be decoupled to AGND with one 10 μF tantalum capacitor and a 0.1 μF ceramic capacitor.
6, 7, 13, 24, 34, 55, 58	AGND1 to AGND7	Analog Ground. Ground reference point for all analog circuitry on the AD7294-2. Refer all analog input signals and any external reference signal to this AGND voltage. Connect all seven of these AGND pins to the AGND plane of the system. Note that AGND5 is a DAC ground reference point and should be used as a star ground for circuitry being driven by the DAC outputs. Ideally, the AGND and DGND voltages should be at the same potential and must not be more than 0.3 V apart, even on a transient basis.
9, 12	D2(-), D1(-)	Temperature Sensor Analog Inputs. These pins are connected to the external temperature sensing transistor. See Figure 43 and Figure 44.
10, 11	D2(+), D1(+)	Temperature Sensor Analog Inputs. These pins are connected to the external temperature sensing transistor. See Figure 43 and Figure 44.
15	REF _{OUT} /REF _{IN} DAC	DAC Reference Output/Input Pin. The REF _{OUT} /REF _{IN} DAC pin is common to all four DAC channels. On power-up, the default configuration of this pin is as an external reference (REF _{IN}). Enable the internal reference by writing to the power-down register; see Table 27. Decoupling capacitors (220 nF recommended) are connected to this pin to decouple the reference buffer. If the output is buffered, the on-chip reference can be taken from this pin and applied externally to the rest of a system. A maximum external reference voltage of AV _{DD} - 2 V can be supplied to the REF _{OUT} portion of the REF _{OUT} /REF _{IN} DAC pin.

Pin No.	Mnemonic	Description
18, 23, 26, 31	OFFSET IN A to OFFSET IN D	DAC Analog Offset Input Pins. These pins set the desired output range for each DAC channel. The DACs have an output voltage span of 5 V, which can be shifted from 0 V to 5 V to a maximum output voltage of 10 V to 15 V by supplying an offset voltage to these pins. These pins can be left floating, in which case decouple them to AGND with a 100 nF capacitor.
19, 22, 27, 30	V _{OUTA} to V _{OUTD}	Buffered Analog DAC Outputs for Channel A to Channel D. Each DAC analog output is driven from an output amplifier that can be offset using the OFFSET IN x pin. The DAC has a maximum output voltage span of 5 V that can be level shifted to a maximum output voltage level of 15 V. Each output is capable of sourcing and sinking 10 mA and driving a 10 nF load.
20, 29	DAC OUT GND AB, DAC OUT GND CD	Analog Ground. Analog ground pins for the DAC output amplifiers on V _{OUTA} and V _{OUTB} , and V _{OUTC} and V _{OUTD} , respectively.
21, 28	DAC OUTV+ AB, DAC OUTV+ CD	Analog Supply. Analog supply pins for the DAC output amplifiers on V _{OUTA} and V _{OUTB} , and V _{OUTC} and V _{OUTD} , respectively. The operating range is 4.5 V to 16.5 V.
35	ALERT/BUSY	Digital Output. Selectable as an alert or busy output function in the configuration register. This is an open-drain output. An external pull-up resistor is required. When configured as an alert, this pin acts as an out-of-range indicator and becomes active when the conversion result violates the DATA _{HIGH} or DATA _{LOW} register values. See the Alert Status Registers section. When configured as a busy output, this pin becomes active when a conversion is in progress.
38, 37, 36	AS0, AS1, AS2	Digital Logic Inputs. Together, the logic state of these inputs selects a unique I ² C address for the AD7294-2 . See Table 34 for more information.
39	SDA	Digital Input/Output. Serial bus bidirectional data; external pull-up resistor required.
40	SCL	Serial I ² C Bus Clock. The data transfer rate in I ² C mode is compatible with both 100 kHz and 400 kHz operating modes. Open-drain input; external pull-up resistor required.
41	OPGND	Dedicated Ground Pin for I ² C Interface.
42	V _{DRIVE}	Logic Power Supply. The voltage supplied at this pin determines at what voltage the interface operates. Decouple this pin to DGND. The voltage range on this pin is 2.7 V to 5.5 V; it may be different from the voltage level at AV _{DD} but should never exceed it by more than 0.3 V. To set the input and output thresholds, connect this pin to the supply to which the I ² C bus is pulled.
43, 47, 48 44	DGND RESET	Digital Ground. This pin is the ground for all digital circuitry. Reset. Taking $\overline{\text{RESET}}$ low performs a reset of the I ² C interface logic. The logic input threshold of the pin is set by V _{DRIVE} (Pin 42). To maintain pin compatibility with the AD7294 , this pin can tolerate being connected to voltages of up to 5.5 V.
46, 45	I _{SENSE1} OVERRANGE, I _{SENSE2} OVERRANGE	Fault Comparator Outputs. These pins connect to the high-side current sense amplifiers.
49, 50, 51, 52	V _{IN3} to V _{IN0}	Uncommitted ADC Analog Inputs. These pins are programmable as four single-ended channels or two true differential analog input channel pairs. See Table 2 and Table 10 for more information.
53	REF _{OUT} /REF _{IN} ADC	ADC Reference Output/Input Pin. The REF _{OUT} /REF _{IN} ADC pin provides the reference source for the ADC. On power-up, the default configuration of this pin is as an external reference (REF _{IN}). Enable the internal reference by writing to the power-down register (see Table 27). Connect decoupling capacitors (220 nF recommended) to this pin to decouple the reference buffer. If the output is buffered, the on-chip reference can be taken from this pin and applied externally to the rest of a system. A maximum external reference voltage of 2.5 V can be supplied to the REF _{OUT} portion of this pin.
54	DCAP	External Decoupling Capacitor Input for Internal Temperature Sensor. Decouple this pin to AGND using a 0.1 μF capacitor. In normal operation, the voltage is typically 1.25 V.
62, 63	V _{PP1} , V _{PP2}	Current Sensor Supply Pins. Power supply pins for the high-side current sense amplifiers. The operating range is from AV _{DD} to 59.4 V. Decouple these supplies to AGND. Refer to the Current Sense Filtering section for more information about using these pins.

TYPICAL PERFORMANCE CHARACTERISTICS

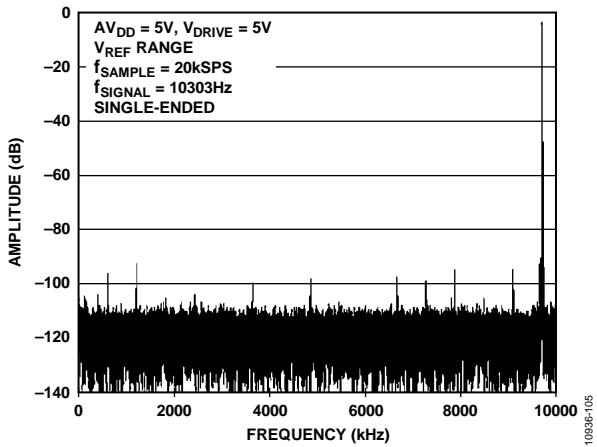

Figure 5. Signal-to-Noise Ratio, Single-Ended Input, V_{REF} Range

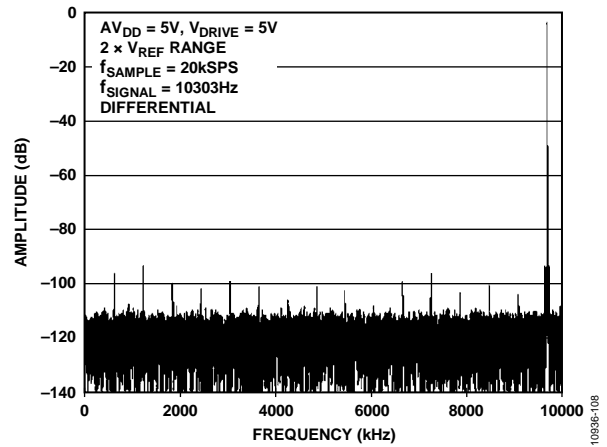

Figure 8. Signal-to-Noise Ratio, Differential Input, $2 \times V_{REF}$ Range

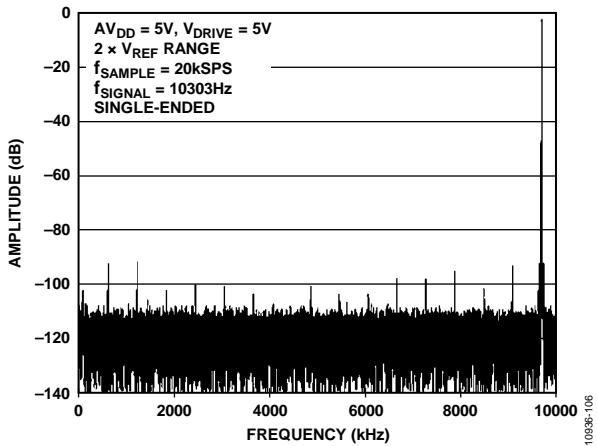

Figure 6. Signal-to-Noise Ratio, Single-Ended Input, $2 \times V_{REF}$ Range

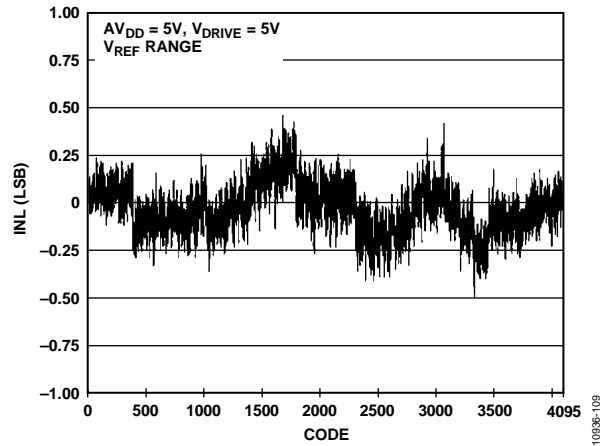

Figure 9. ADC INL, Single-Ended Input, V_{REF} Range

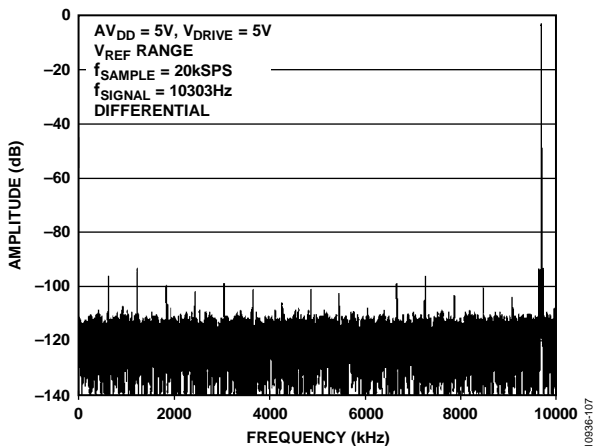

Figure 7. Signal-to-Noise Ratio, Differential Input, V_{REF} Range

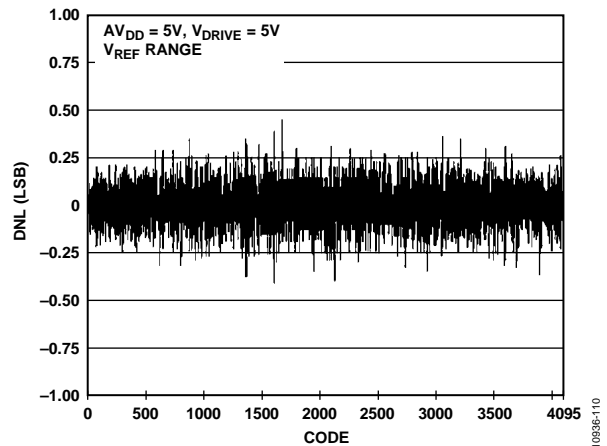

Figure 10. ADC DNL, Single-Ended Input, V_{REF} Range

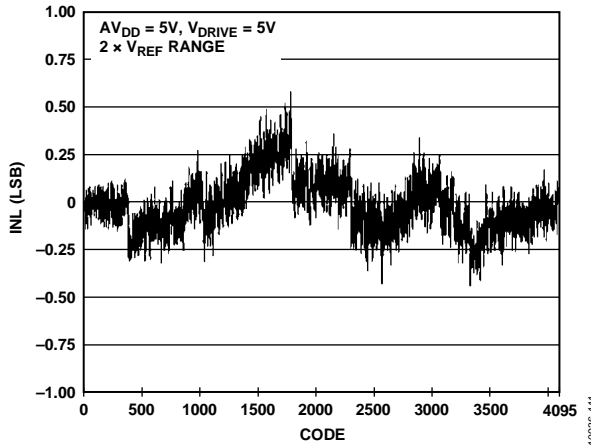

Figure 11. ADC INL, Single-Ended Input, $2 \times V_{REF}$ Range

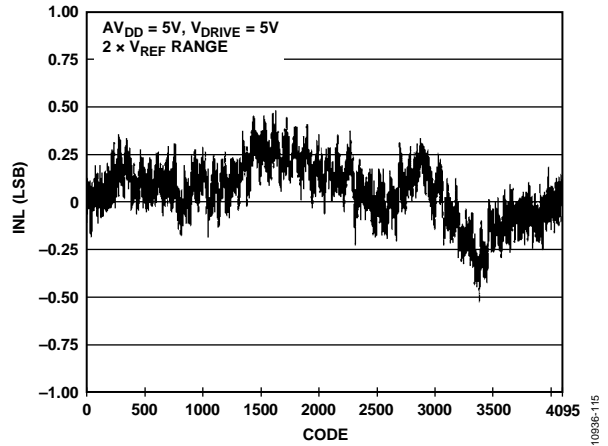

Figure 14. ADC INL, Differential Input, V_{REF} Range

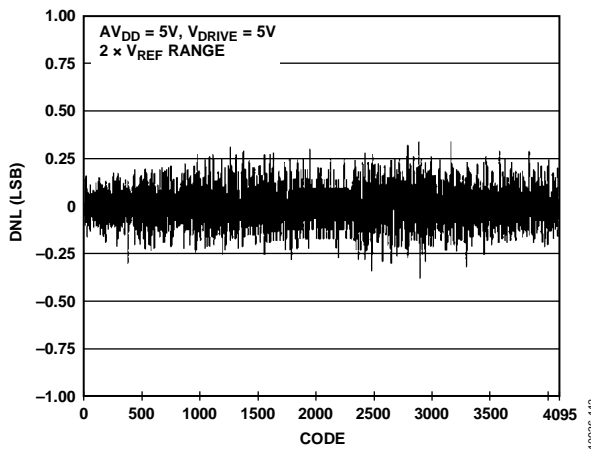

Figure 12. ADC DNL, Single-Ended Input, $2 \times V_{REF}$ Range

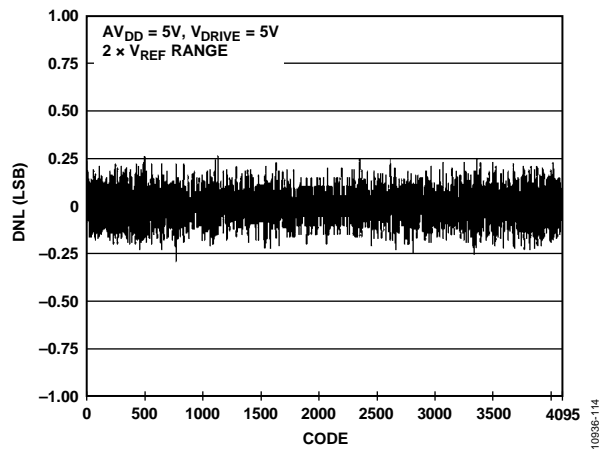

Figure 15. ADC DNL, Differential Input, $2 \times V_{REF}$ Range

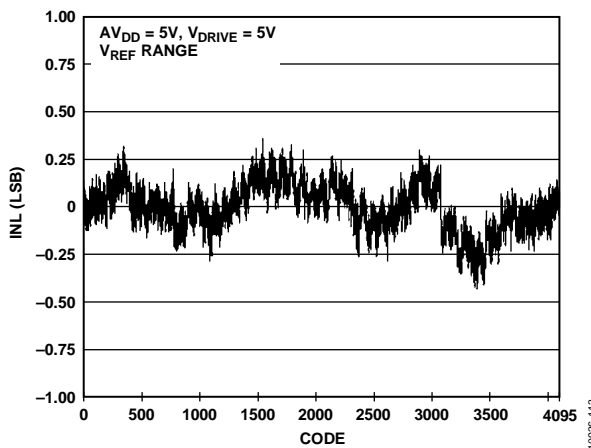

Figure 13. ADC INL, Differential Input, V_{REF} Range

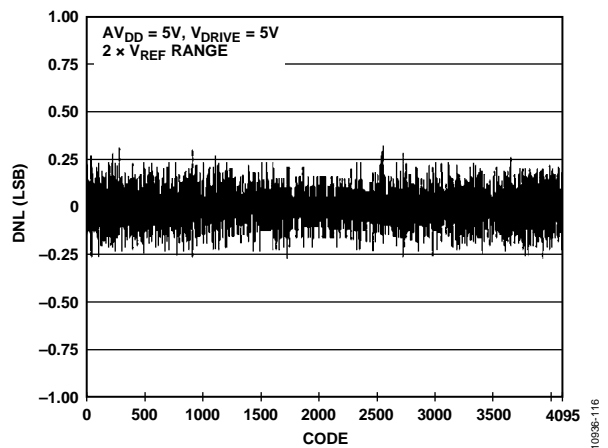

Figure 16. ADC DNL, Differential Input, $2 \times V_{REF}$ Range

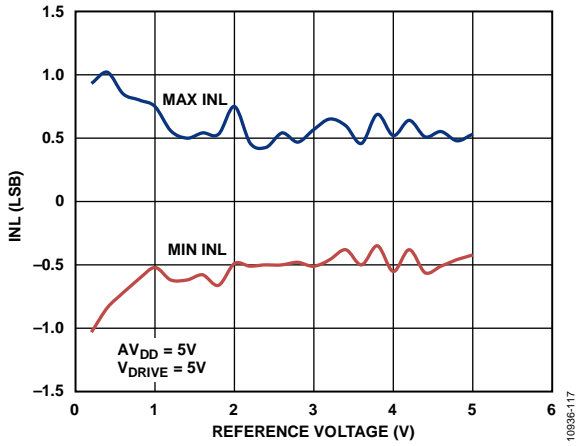

Figure 17. ADC INL vs. Reference Voltage

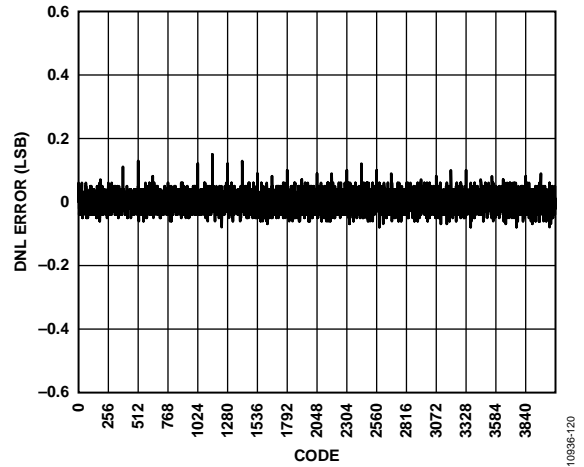

Figure 20. DAC DNL

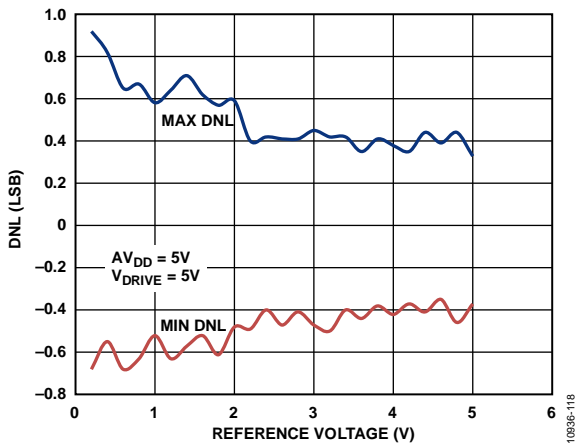

Figure 18. ADC DNL vs. Reference Voltage

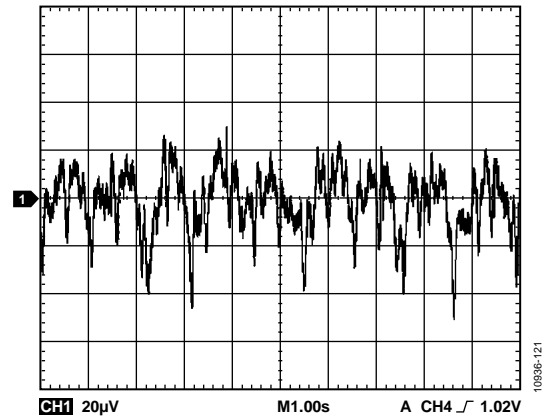

Figure 21. 0.1 Hz to 10 Hz DAC Output Noise, Input Code = 0x800

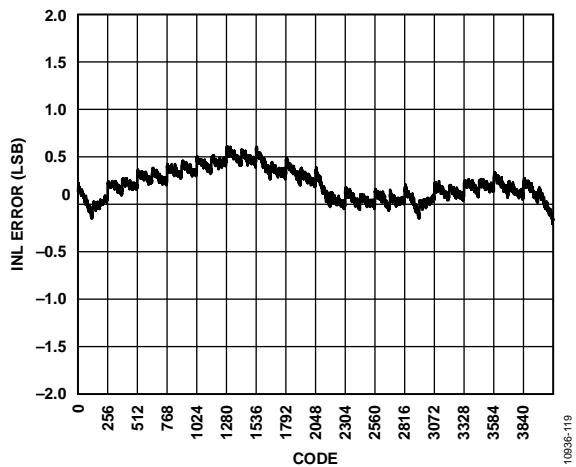

Figure 19. DAC INL

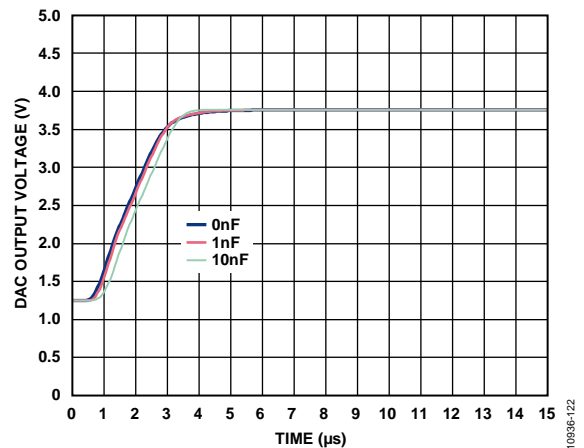

Figure 22. Settling Time for a 1/4 to 3/4 Output Voltage Step

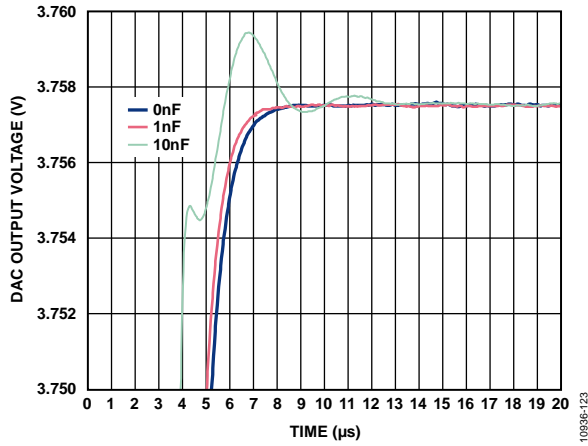

Figure 23. Zoomed-In Settling Time for a 1/4 to 3/4 Output Voltage Step

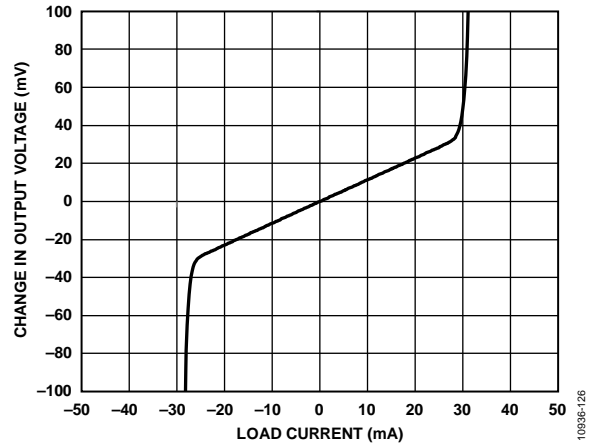

Figure 26. DAC Output Voltage vs. Load Current, Input Code = 0x800

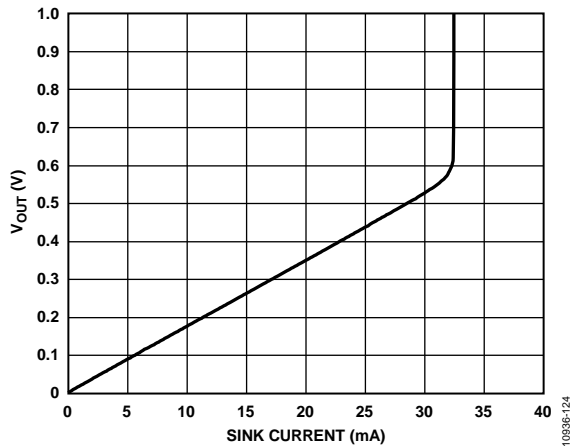

Figure 24. DAC Sinking Current at Input Code = 0x000, ($V_{OUT} = 0\text{ V}$)

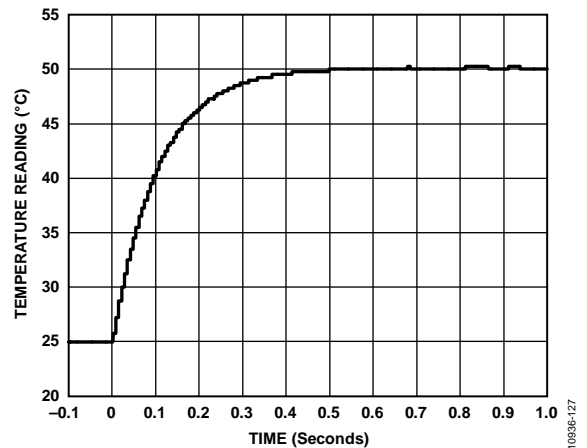

Figure 27. Response of Temperature Sensor to a Step Function

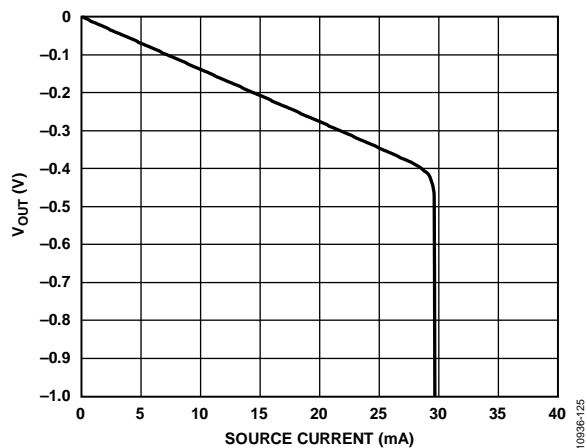

Figure 25. DAC Sourcing Current at Input Code = 0xFF, ($V_{OUT} = AV_{DD}$)

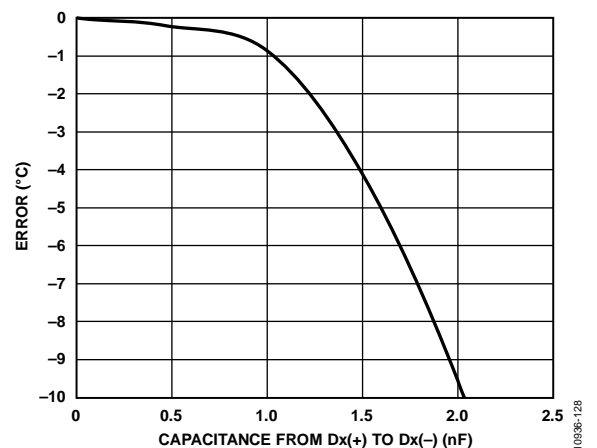

Figure 28. Temperature Error vs. Capacitance from $Dx(+)$ to $Dx(-)$

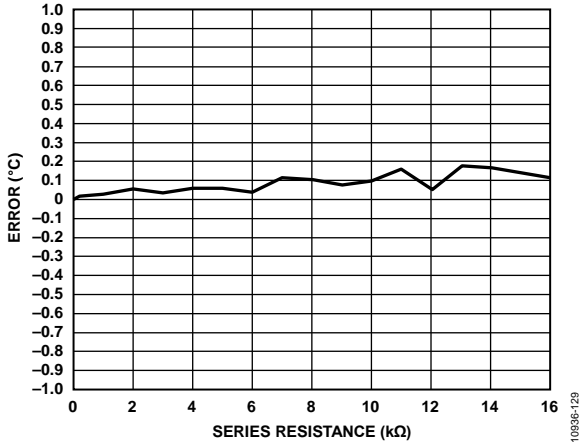

Figure 29. Temperature Error vs. Series Resistance

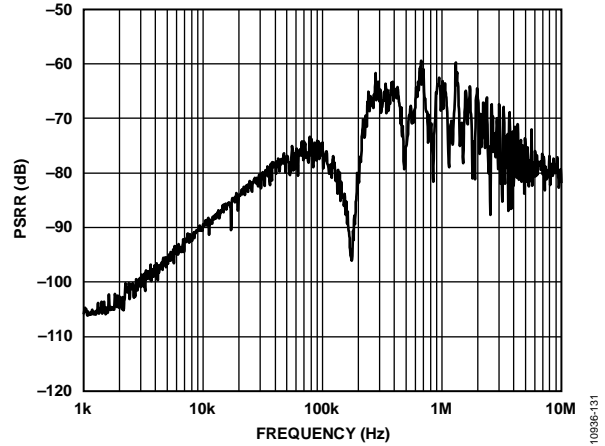

Figure 31. I_{SENSE} Power Supply Rejection Ratio (PSRR) vs. Supply Ripple Frequency Without V_{PP} Supply Decoupling Capacitors for a 500 mV Ripple

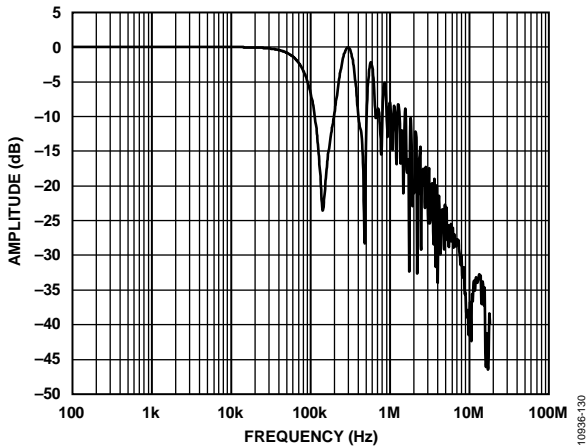

Figure 30. Frequency Response of the High-Side Current Sensor

TERMINOLOGY

DAC TERMINOLOGY

Relative Accuracy

A measure of the maximum deviation, in LSBs, from a straight line passing through the endpoints of the DAC transfer function.

Differential Nonlinearity (DNL)

The difference between the measured change and the ideal 1 LSB change between any two adjacent codes. A specified differential nonlinearity of ± 1 LSB maximum ensures monotonicity. This DAC is guaranteed monotonic by design.

Zero Code Error

A measure of the output error when zero code (0x0000) is loaded to the DAC register. Ideally, the output should be 0 V. The zero code error is always positive in the AD7294-2 because the output of the DAC cannot go below 0 V. Zero code error is expressed in mV.

Full-Scale Error

A measure of the output error when full-scale code (0xFFFF) is loaded to the DAC register. Ideally, the output should be $V_{DD} - 1$ LSB. Full-scale error is expressed in mV.

Gain Error

A measure of the span error of the DAC. It is the deviation in slope of the DAC transfer characteristic from ideal, expressed as a percent of the full-scale range (% FSR).

Gain Error Drift

A measure of the change in gain error with changes in temperature. It is expressed in (ppm of full-scale range)/°C.

ADC TERMINOLOGY

Signal-to-Noise-and-Distortion Ratio (SINAD)

The measured ratio of signal-to-noise and distortion at the output of the ADC. The signal is the rms amplitude of the fundamental. Noise is the sum of all nonfundamental signals up to half the sampling frequency ($f_s/2$), excluding dc. The ratio is dependent on the number of quantization levels in the digitization process; the more levels, the smaller the quantization

noise. The theoretical signal-to-noise-and-distortion ratio for an ideal N-bit converter with a sine wave input is given by

$$\text{Signal-to-Noise-and-Distortion} = (6.02 N + 1.76) \text{ dB}$$

Thus, the SINAD is 74 dB for an ideal 12-bit converter.

Total Harmonic Distortion (THD)

The ratio of the rms sum of harmonics to the fundamental. For the AD7294-2, THD is defined as

$$\text{THD(dB)} = 20 \log \frac{\sqrt{V_2^2 + V_3^2 + V_4^2 + V_5^2 + V_6^2}}{V_1}$$

where V_1 is the rms amplitude of the fundamental and V_2 , V_3 , V_4 , V_5 , and V_6 are the rms amplitudes of the second through sixth harmonics.

Integral Nonlinearity (INL)

The maximum deviation from a straight line passing through the endpoints of the ADC transfer function. The endpoints are zero scale, a point 1 LSB below the first code transition, and full scale, a point 1 LSB above the last code transition.

Differential Nonlinearity (DNL)

The difference between the measured change and the ideal 1 LSB change between any two adjacent codes in the ADC.

Offset Error

The deviation of the first code transition (00...000) to (00...001) from the ideal—that is, AGND + 1 LSB.

Offset Error Match

The difference in offset error between any two channels.

Gain Error

The deviation of the last code transition (111 ... 110 to 111 ... 111) from the ideal (that is, $REF_{IN} - 1$ LSB) after the offset error has been adjusted out.

Gain Error Match

The difference in gain error between any two channels.

THEORY OF OPERATION

ADC OVERVIEW

The AD7294-2 provides the user with a 9-channel multiplexer, an on-chip track-and-hold, and a successive approximation ADC based on four capacitive DACs. The analog input range for the part can be selected as a 0 V to V_{REF} input or a $2 \times V_{REF}$ input, configured with either single-ended or differential analog inputs. An on-chip 2.5 V reference can be disabled when an external reference is preferred. If the internal ADC reference is to be used elsewhere in a system, the output must first be buffered.

The various monitored and uncommitted input signals are multiplexed into the ADC. The AD7294-2 has four uncommitted analog input channels, V_{IN0} to V_{IN3} . These four channels allow single-ended, differential, and pseudo differential mode measurements of various system signals.

ADC TRANSFER FUNCTIONS

The designed code transitions occur at successive integer LSB values (1 LSB, 2 LSB, and so on). In single-ended mode, the LSB size is $V_{REF}/4096$ when the 0 V to V_{REF} range is used, and $2 \times V_{REF}/4096$ when the 0 V to $2 \times V_{REF}$ range is used. The ideal transfer characteristic for the ADC, when outputting straight binary coding, is shown in Figure 32.

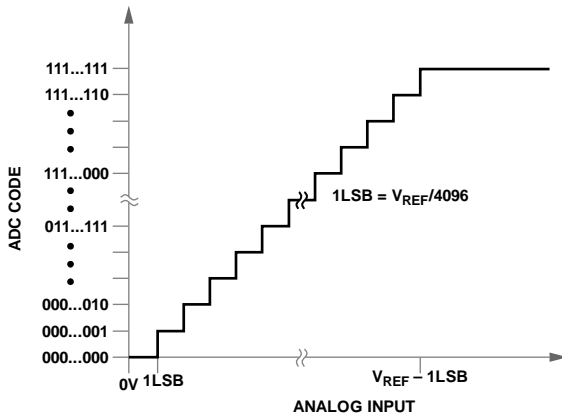

NOTE

1. V_{REF} IS EITHER V_{REF} OR $2 \times V_{REF}$.

Figure 32. Single-Ended Transfer Characteristics

In differential mode, the LSB size is $2 \times V_{REF}/4096$ when the 0 V to V_{REF} range is used, and $4 \times V_{REF}/4096$ when the 0 V to $2 \times V_{REF}$ range is used. The ideal transfer characteristic for the ADC, when outputting two's complement coding, is shown in Figure 33 (with the $2 \times V_{REF}$ range).

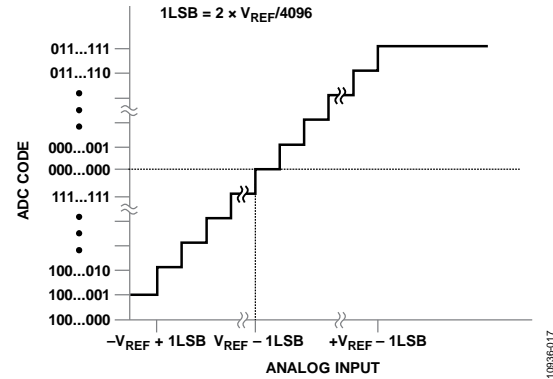

Figure 33. Differential Transfer Characteristics with $V_{REF} \pm V_{REF}$ Input Range

For V_{IN0} to V_{IN3} in single-ended mode, the output code is straight binary, where

$$V_{IN} = 0 \text{ V}, D_{OUT} = \text{x000}, V_{IN} = V_{REF} - 1 \text{ LSB}, \text{ and } D_{OUT} = \text{0xFFFF}$$

In differential mode, the code is two's complement, where

$$V_{IN+} - V_{IN-} = 0 \text{ V}, \text{ and } D_{OUT} = \text{0x00}$$

$$V_{IN+} - V_{IN-} = V_{REF} - 1 \text{ LSB}, \text{ and } D_{OUT} = \text{00x7FF}$$

$$V_{IN+} - V_{IN-} = -V_{REF}, \text{ and } D_{OUT} = \text{0x800}$$

Channel 5 and Channel 6 (current sensor inputs) are two's complement, where

$$V_{IN+} - V_{IN-} = 0 \text{ mV}, \text{ and } D_{OUT} = \text{0x000}$$

$$V_{IN+} - V_{IN-} = V_{REF}/12.5 - 1 \text{ LSB}, \text{ and } D_{OUT} = \text{0x7FF}$$

$$V_{IN+} - V_{IN-} = -V_{REF}/12.5, \text{ and } D_{OUT} = \text{0x800}$$

Channel 7 to Channel 9 (temperature sensor inputs) are two's complement with the LSB equal to 0.25°C, where

$$T_{IN} = 0^\circ\text{C}, \text{ and } D_{OUT} = \text{0x000}$$

$$T_{IN} = +255.75^\circ\text{C}, \text{ and } D_{OUT} = \text{0x7FF}$$

$$T_{IN} = -256^\circ\text{C}, \text{ and } D_{OUT} = \text{0x800}$$

ANALOG INPUTS

The AD7294-2 has four analog inputs, V_{IN3} to V_{IN0} . Depending on the configuration register setup, they can be configured as two single-ended inputs, two pseudo differential channels, or two fully differential channels (see the Register Settings section).

Single-Ended Mode

The AD7294-2 can have four single-ended analog input channels. In applications where the signal source has high impedance, it is recommended that the analog input be buffered before it is applied to the ADC. The analog input range can be programmed to either of the following modes: 0 V to V_{REF} or 0 V to $2 \times V_{REF}$. In $2 \times V_{REF}$ mode, the input is effectively divided by 2 before the conversion takes place. Note that the voltage, with respect to GND on the ADC analog input pins, cannot exceed AV_{DD} .

If the analog input signal to be sampled is bipolar, the internal reference of the ADC can be used to externally bias up this signal so that it is correctly formatted for the ADC. Figure 34 shows a typical connection diagram when operating the ADC in single-ended mode.

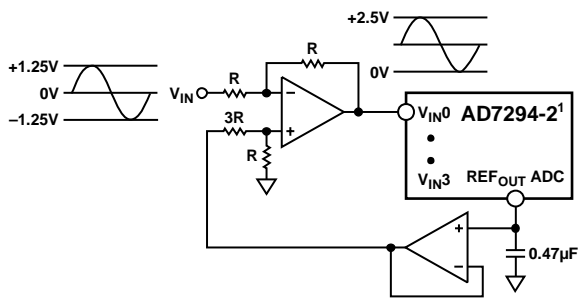

¹ADDITIONAL PINS OMITTED FOR CLARITY.

Figure 34. Single-Ended Mode Connection Diagram

Differential Mode

The AD7294-2 can have two differential analog input pairs. Differential signals have some benefits over single-ended signals, including noise immunity based on the common-mode rejection of the device and improvements in distortion performance. Figure 35 defines the fully differential analog input of the AD7294-2.

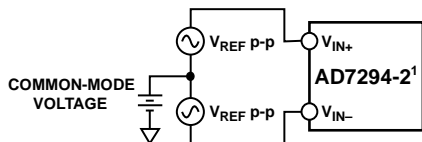

¹ADDITIONAL PINS OMITTED FOR CLARITY.

Figure 35. Differential Input Definition

The amplitude of the differential signal is the difference between the signals applied to V_{IN+} and V_{IN-} in each differential pair ($V_{IN+} - V_{IN-}$). The resulting converted data is stored in twos complement format in the result register.

Simultaneously drive V_{IN0} and V_{IN1} by two signals, each of amplitude V_{REF} (or $2 \times V_{REF}$, depending on the range chosen), that are 180° out of phase.

Assuming that the 0 V to V_{REF} range is selected, the amplitude of the differential signal is, therefore, $-V_{REF}$ to $+V_{REF}$ peak-to-peak ($2 \times V_{REF}$), regardless of the common-mode voltage (V_{CM}).

The common-mode voltage is the average of the two signals.

$$(V_{IN+} + V_{IN-})/2$$

The common-mode voltage is, therefore, the voltage on which the two inputs are centered.

The result is that the span of each input is $V_{CM} \pm V_{REF}/2$. This common-mode voltage must be set up externally, and its range varies with the reference value, V_{REF} . As the value of V_{REF} increases, the common-mode range decreases. When driving the inputs with an amplifier, the actual common-mode range is determined by the output voltage swing of the amplifier.

The common-mode voltage must be within this common-mode range to guarantee the functionality of the AD7294-2.

When a conversion takes place, the common-mode voltage is rejected, resulting in a virtually noise-free signal of amplitude $-V_{REF}$ to $+V_{REF}$, corresponding to the digital output codes of -2048 to $+2047$ in twos complement format.

If the $2 \times V_{REF}$ range is used, the input signal amplitude extends from $-2 \times V_{REF}$ ($V_{IN+} = 0$ V, $V_{IN-} = V_{REF}$) to $+2 \times V_{REF}$ ($V_{IN-} = 0$ V, $V_{IN+} = V_{REF}$).

Driving Differential Inputs

The differential modes that are available on V_{IN0} to V_{IN3} (see Table 10) require that V_{IN+} and V_{IN-} be driven simultaneously with two equal signals that are 180° out of phase. The common-mode voltage on which the analog input is centered must be set up externally. The common-mode range is determined by V_{REF} , the power supply, and the particular amplifier used to drive the analog inputs. Differential modes of operation with either an ac or dc input provide the best THD performance over a wide frequency range. Because not all applications have a signal that is preconditioned for differential operation, there is often a need to perform a single-ended-to-differential conversion.

Using an Op Amp Pair

An op amp pair can be used to directly couple a differential signal to one of the analog input pairs of the AD7294-2. The circuit configuration that is illustrated in Figure 38 shows how a dual op amp can be used to convert a single-ended bipolar signal into a differential unipolar input signal.

The voltage applied to Point A sets up the common-mode voltage. As shown in Figure 38, Point A connects to the reference, but any value in the common-mode range can be the input at Point A to set up the common-mode voltage. The AD8022 is a suitable dual op amp that can be used in this configuration to provide differential drive to the AD7294-2.

Care is required when choosing the op amp because the selection depends on the required power supply and system performance objectives. The driver circuit in Figure 38 is optimized for dc coupling applications that require best distortion performance.

The differential op amp driver circuit shown in Figure 38 is configured to convert and level shift a single-ended, ground referenced (bipolar) signal to a differential signal that is centered at the V_{REF} level of the ADC.

Pseudo Differential Mode

The four uncommitted analog input channels can be configured as two pseudo differential pairs. Two uncommitted inputs, V_{IN0} and V_{IN1} , are a pseudo differential pair, as are V_{IN2} and V_{IN3} . In this mode, V_{IN+} is connected to the signal source, which can have a maximum amplitude of V_{REF} (or $2 \times V_{REF}$, depending on the range that is chosen) to make use of the full dynamic range of the part. A dc input is applied to V_{IN-} . The voltage applied to this input provides an offset from ground or a pseudo ground for the V_{IN+} input. The channel specified as V_{IN+} is determined by the ADC channel allocation. The differential mode must be selected to operate in the pseudo differential mode. The resulting converted pseudo differential data is stored in twos complement format in the result register.

For V_{IN0} , the governing equation for the pseudo differential mode is

$$V_{OUT} = 2(V_{IN+} - V_{IN-}) - V_{REF_ADC}$$

where V_{IN+} is the single-ended signal and V_{IN-} is a dc voltage.

The benefit of pseudo differential inputs is that they separate the analog input signal ground from the ADC ground, allowing dc common-mode voltages to be cancelled.

Figure 36 shows the typical voltage range for V_{IN-} while in pseudo differential mode, and Figure 37 shows a connection diagram for pseudo differential mode.

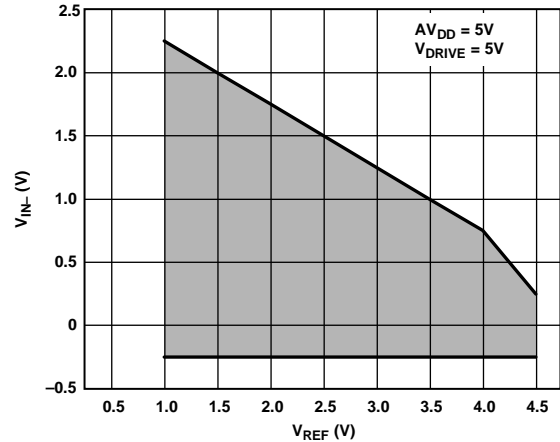
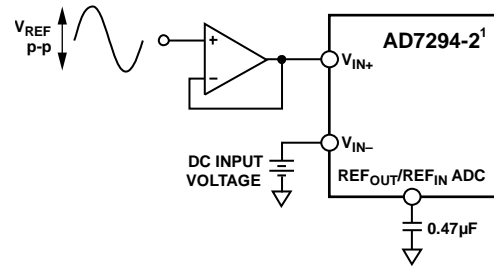

Figure 36. V_{IN-} Input Range vs. V_{REF} in Pseudo Differential Mode



¹ADDITIONAL PINS OMITTED FOR CLARITY.

Figure 37. Pseudo Differential Mode Connection Diagram

CURRENT SENSOR

Two bidirectional high-side current sense amplifiers are provided that can accurately amplify differential current shunt voltages in the presence of high common-mode voltages from AV_{DD} up to 59.4 V. Each amplifier can accept a ± 200 mV differential input. Both current sense amplifiers have a fixed gain of 12.5 and use an internal 2.5 V reference.

An analog comparator is also provided with each amplifier for fault detection. The threshold is defined as

$$1.2 \times \text{Full-Scale Voltage Range}$$

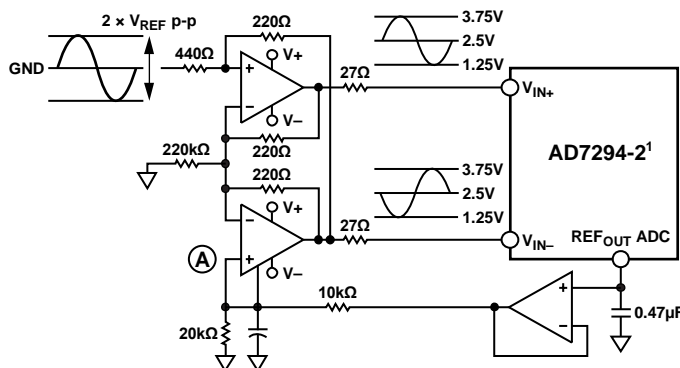

¹ADDITIONAL PINS OMITTED FOR CLARITY.

Figure 38. Dual Op Amp Circuit to Convert a Single-Ended Bipolar Signal into a Differential Unipolar Signal

When this limit is reached, the output is latched onto a dedicated pin. This output remains high until the latch is cleared by writing to the appropriate register.

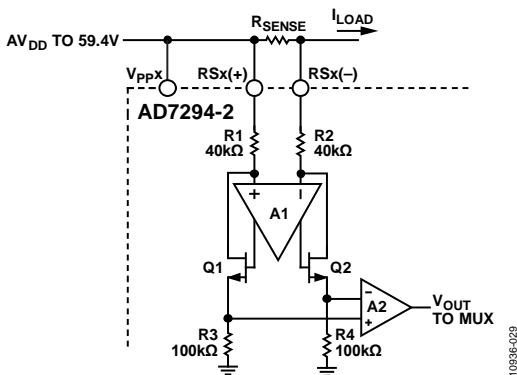

Figure 39. High-Side Current Sense

The AD7294-2 current sense comprises two main blocks: a differential and an instrumentation amplifier. A load current flowing through the external shunt resistor produces a voltage at the input terminals of the AD7294-2. Resistors R1 and R2 connect the input terminals to the differential amplifier (A1). A1 nulls the voltage that appears across its own input terminals by adjusting the current through R1 and R2 with Transistors Q1 and Q2. Common-mode feedback maintains the sum of these currents at approximately 50 μ A. When the input signal to the AD7294-2 is zero, the currents in R1 and R2 are equal. When the differential signal is nonzero, the current increases through one of the resistors and decreases in the other. The current difference is proportional to the size and polarity of the input signal.

The differential currents through Q1 and Q2 are converted into a differential voltage by R3 and R4. A2 is configured as an instrumentation amplifier, buffering this voltage and providing additional gain. Therefore, for an input voltage of ± 200 mV at the pins, an output span of ± 2.5 V is generated.

The current sensors on the AD7294-2 are designed to remove any flicker noise and offset that are present in the sensed signal. This is achieved by using a chopping technique that is transparent to the user. The V_{SENSE} signal is first converted by the AD7294-2, the analog inputs to the amplifiers are then swapped, and the differential voltage is once again converted by the AD7294-2.

The two conversion results enable the digital removal of any offset or noise. Switches on the amplifier inputs enable this chopping technique to be implemented. The process typically requires 6 μ s, in total, to return a final result.

Choosing R_{SENSE}

The resistor values used in conjunction with the current sense amplifiers are determined by the specific application requirements in terms of voltage, current, and power. Small resistors minimize power dissipation, have low inductance to prevent any induced voltage spikes, and provide good tolerance, which reduces current variations. The final values chosen are a compromise between low power dissipation and good accuracy. Low value resistors have less power dissipated in them, but higher value resistors may

be required to use the full input range of the ADC, thus achieving maximum SNR performance.

When the sense current is known, the voltage range of the AD7294-2 current sensor (200 mV) is divided by the maximum sense current to yield a suitable shunt value. If the power dissipation in the shunt resistor is too large, the size of the shunt resistor can be reduced; in this case, less of the ADC input range is used. Using less of the ADC input range produces conversion results that are more susceptible to noise and offset errors because offset errors are fixed and are, thus, more significant when smaller input ranges are used.

R_{SENSE} must be able to dissipate the I^2R losses. If the power dissipation rating of the resistor is exceeded, its value may drift or the resistor may be damaged, resulting in an open circuit. This open circuit can cause a differential voltage across the terminals of the AD7294-2 in excess of the absolute maximum ratings. Additional protection is afforded to the current sensors on the AD7294-2 by the recommended current limiting resistors, RF1 and RF2, as shown in Figure 40. The AD7294-2 can handle a maximum continuous current of 30 mA; thus, an RF2 of 1 k Ω provides adequate protection for the AD7294-2.

If I_{SENSE} has a large high frequency component, take care to choose a resistor with low inductance. Low inductance metal film resistors are best suited for these applications.

Current Sense Filtering

In some applications, it may be desirable to use external filtering to reduce the input bandwidth of the amplifier (see Figure 40). The -3 dB differential bandwidth of this filter is equal to

$$BW_{DM} = 1/(4 \times \pi \times RC)$$

Note that the maximum series resistance on the RS(+) and RS(-) inputs (see Figure 39) is limited to a maximum of 1 k Ω due to back-to-back ESD protection diodes from RS(+) and RS(-) to V_{PPX} . Also, note that if RF1 and RF2 are in series with R1 and R2 (see Figure 39), the gain of the amplifier is affected. Any mismatch between RF1 and RF2 can introduce an offset error.

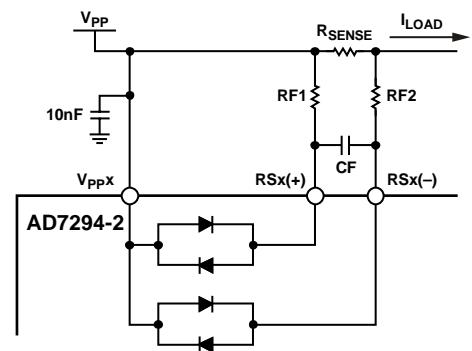

Figure 40. Current Sense Filtering (RS_x Can Be Either RS_1 or RS_2)

For certain RF applications, the optimum value for RF1 and RF2 is 1 k Ω , whereas CF can range from 1 μ F to 10 μ F. There is an additional decoupling capacitor for the V_{PPX} supply. Its value is application dependent, but for initial evaluation, values in the range of 1 nF to 100 nF are recommended.

Kelvin Sense Resistor Connection

When using a low value sense resistor for high current measurement, the problem of parasitic series resistance can arise. The lead resistance can be a substantial fraction of the rated resistance, making the total resistance a function of lead length. Avoid this problem by using a Kelvin sense connection. This type of connection separates the current path through the resistor and the voltage drop across the resistor. Figure 41 shows the correct way to connect the sense resistor between the RS(+) and RS(-) pins of the AD7294-2.

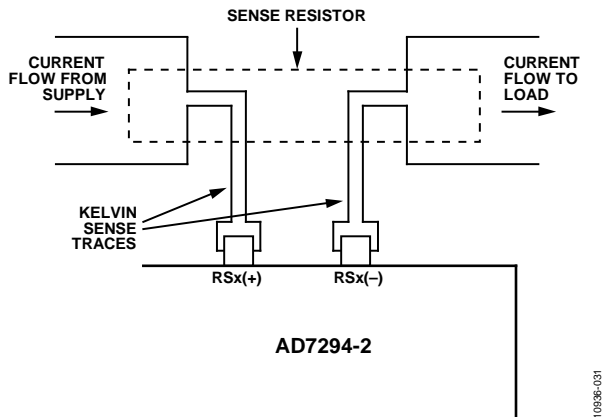

Figure 41. Kelvin Sense Connections (RSx Can Be Either RS1 or RS2)

ANALOG COMPARATOR LOOP

The AD7294-2 contains two setpoint comparators that are used for independent analog control. This circuitry enables users to quickly detect if the sensed voltage across the shunt resistor has increased above the preset $(V_{REF} \times 1.2)/12.5$. If this increase occurs, the I_{SENSEX} OVERRANGE pin is set to a high logic level, enabling appropriate action to be taken to prevent any damage to the external circuitry.

The setpoint threshold level is fixed internally in the AD7294-2, and the current sense amplifier saturates above this level. The comparator is also triggered if a voltage of less than AV_{DD} is applied to the R_{SENSE} resistor or the V_{PPX} pin.

TEMPERATURE SENSOR

The AD7294-2 contains one local and two remote temperature sensors. The temperature sensors continuously monitor the three temperature inputs, and new readings are automatically available every 5 ms.

The on-chip, band gap temperature sensor measures the temperature of the system. Diodes are used in conjunction with the two remote temperature sensors to monitor the temperature of other critical board components.

The temperature sensor module on the AD7294-2 is based on the three-current principle (see Figure 42), where three currents are passed through a diode and the forward voltage drop is measured at each diode, allowing the temperature to be calculated free of errors caused by series resistance.

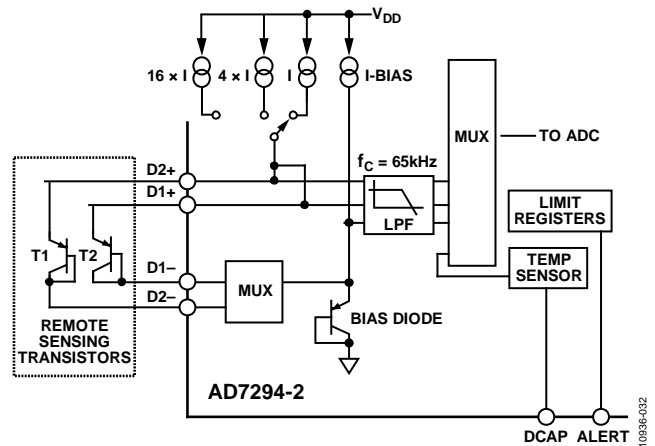

Figure 42. Internal and Remote Temperature Sensors

Each input integrates, in turn, over a period of several hundred microseconds (μ s). This integration takes place continuously in the background, leaving the user free to perform conversions on the other channels. When the integration is complete, a signal passes to the control logic to initiate a conversion automatically. If the ADC is in command mode, the temperature conversion is performed as soon as the next conversion is completed. In auto-cycle mode, the conversion is inserted into an appropriate place in the current sequence (see the Register Settings section for further details). If the ADC is idle, the conversion takes place immediately.

Three registers store the result of the last conversion on each temperature channel; these can be read at any time. In addition, in command mode, one or both of the two external channel registers can be read out as part of the output sequence.

Remote Sensing Diode

The AD7294-2 is designed to work with discrete transistors, 2N3904 and 2N3906. If an alternative transistor is used, the AD7294-2 operates as specified, provided that the conditions explained in the following sections are adhered to.

Ideality Factor

The ideality factor of the transistor, n_f , is a measure of the deviation of the thermal diode from ideal behavior. The AD7294-2 is trimmed for an n_f value of 1.008. Use the following equation to calculate the error introduced at a Temperature T ($^{\circ}$ C) when using a transistor whose n_f does not equal 1.008:

$$\Delta T = (n_f - 1.008) \times (273.15 \text{ K} + T)$$

To factor in this error, the user can write the ΔT value to the offset register. The AD7294-2 automatically adds it to, or subtracts it from, the temperature measurement.

Base Emitter Voltage

The AD7294-2 operates as specified if the base emitter voltage is greater than 0.25 V at 8 μ A at the highest operating temperature, and less than 0.95 V at 128 μ A for the lowest operating temperature.

h_{FE} Variation

Use a transistor with little variation in h_{FE} (~50 to 150). Little variation in h_{FE} indicates tight control of the V_{BE} characteristics.

For RF applications, the use of high Q capacitors, functioning as a filter, protects the integrity of the measurement. Connect these capacitors, such as Johanson Technology 10 pF, high Q capacitors, Reference Code 500R07S100JV4T, between the base and the emitter, as close to the external device as possible. However, large capacitances affect the accuracy of the temperature measurement; thus, the recommended maximum capacitor value is 100 pF. In most cases, a capacitor is not required; the selection of any capacitor is dependent on the noise frequency level.

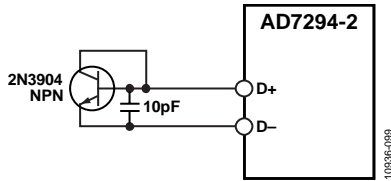

Figure 43. Measuring Temperature Using an NPN Transistor

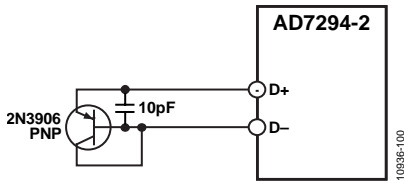

Figure 44. Measuring Temperature Using a PNP Transistor

Series Resistance Cancellation

The AD7294-2 is designed to automatically cancel out the effect of parasitic, base, and collector resistance on the temperature reading. This feature provides a more accurate result, without the need for any user characterization of the parasitic resistance. The AD7294-2 can compensate for up to 10 kΩ in a process that is transparent to the user.

DAC OPERATION

The AD7294-2 contains four 12-bit DACs that provide digital control with 12 bits of resolution and a 2.5 V internal reference. The DAC core is a thin film 12-bit string DAC with a 5 V output span and an output buffer that can drive the high voltage output stage. The DAC has a span of 0 V to 5 V with a 2.5 V reference input. The output range of the DAC, which is controlled by the offset input, can be positioned from 0 V to 15 V.

Resistor String

The resistor string structure is shown in Figure 45. It consists of a string of 2ⁿ resistors, each of Value R. The code loaded to the DAC register determines at which node on the string the voltage is tapped off to be fed into the output amplifier. The voltage is tapped off by closing one of the switches connecting the string

to the amplifier. This architecture is inherently monotonic, voltage out, and low glitch. It is also linear because all of the resistors are of equal value.

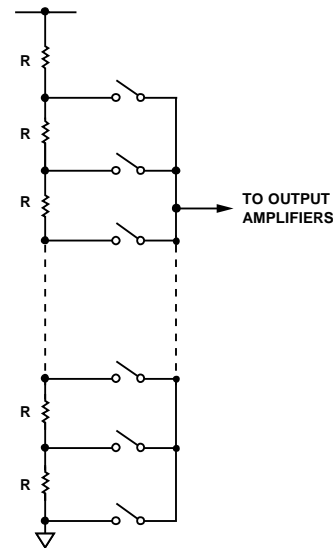

Figure 45. Resistor String Structure

Output Amplifiers

The purpose of Op Amp A1 is to buffer the DAC output range from 0 V to V_{REF}. A second amplifier, Op Amp A2, is configured such that when an offset is applied to OFFSET IN x, its output voltage is 3× the offset voltage minus 2× the DAC voltage.

$$V_{OUT} = 3 \times V_{OFFSET} - 2 \times V_{DAC}$$

The DAC word is digitally inverted on chip such that

$$V_{OUT} = 3 \times V_{OFFSET} + 2 \times (V_{DAC} - V_{REF})$$

$$\text{and } V_{DAC} = \left[V_{REF} \times \left(\frac{D}{2^n} \right) \right]$$

where:

V_{DAC} is the output of the DAC before digital inversion.

D is the decimal equivalent of the binary code that is loaded to the DAC register.

n is the bit resolution of the DAC.

An example of the offset function is given in Table 8.

Table 8. Offset Voltage Function Example

Offset Voltage (V)	V _{OUT} with 0x000 (V)	V _{OUT} with 0xFF (LSB)
1.67	0	5 V – 1
3.33	5	10 V – 1
5.00	10	15 V – 1

The user has the option of leaving the offset pin open, in which case the voltage on the noninverting input of Op Amp A2 is set by the resistor divider, giving

$$V_{OUT} = 2 \times V_{DAC}$$

This configuration generates the 5 V output span from a 2.5 V reference. Digitally inverting the DAC allows the circuit to operate as a generic DAC when no offset is applied. If the offset pin is not driven, it is best practice to place a 100 nF capacitor between the pin and ground to improve both the settling time and the noise performance of the DAC.

Note that a significant amount of power can be dissipated in the DAC outputs.

ADC AND DAC REFERENCE

The [AD7294-2](#) has two independent, internal, high performance 2.5 V references, one for the ADC and the other for the four on-chip DACs. If the application requires an external reference, it can be applied to the REF_{OUT}/REF_{IN} DAC pin and/or to the REF_{OUT}/REF_{IN} ADC pin. Buffer the internal reference before it is used by external circuitry. Decouple both the REF_{OUT}/REF_{IN} DAC pin and the REF_{OUT}/REF_{IN} ADC pin to AGND, using a 220 nF capacitor. On power-up, the [AD7294-2](#) is configured for use with an external reference. To enable the internal references, write a zero to both the D4 and D5 bits in the power-down register (see the Register Settings section). Both the ADC and DAC references require a minimum of 60 μ s to power up and settle to 12-bit performance when a 220 nF decoupling capacitor is used.

The [AD7294-2](#) can also operate with an external reference. Suitable reference sources for the [AD7294-2](#) include the [AD780](#),

[AD1582](#), [ADR431](#), [REF193](#), and [ADR391](#). In addition, choosing a reference with an output trim adjustment, such as the [ADR441](#), allows a system designer to trim system errors by setting a reference voltage to a voltage other than the nominal.

Long-term drift is a measure of how much the reference drifts over time. A reference with a low long-term drift specification ensures that the overall solution remains stable during its entire lifetime. If an external reference is used, select a low temperature coefficient specification to reduce the temperature dependence of the system output voltage on ambient conditions.

V_{DRIVE} FEATURE

The [AD7294-2](#) also has a V_{DRIVE} feature to control the voltage at which the I²C interface operates. The V_{DRIVE} pin is connected to the supply to which the I²C bus is pulled. This pin sets the input and output threshold levels for the digital logic pins and the I_{SENSEX} OVERRANGE pins. The V_{DRIVE} feature allows the [AD7294-2](#) to easily interface to both 3 V and 5 V processors.

For example, if the [AD7294-2](#) is operated with a V_{DD} of 5 V, the V_{DRIVE} pin can be powered from a 3 V supply, allowing a large dynamic range with low voltage digital processors. Thus, the [AD7294-2](#) can be used with the $2 \times V_{REF}$ input range with a V_{DD} of 5 V, yet it remains capable of interfacing to 3 V digital parts. Decouple the V_{DRIVE} pin to DGND with a 100 nF capacitor and a 1 μ F capacitor.

REGISTER SETTINGS

The AD7294-2 contains internal registers (see Figure 46) that store conversion results, high and low conversion limits, and information to configure and control the device.

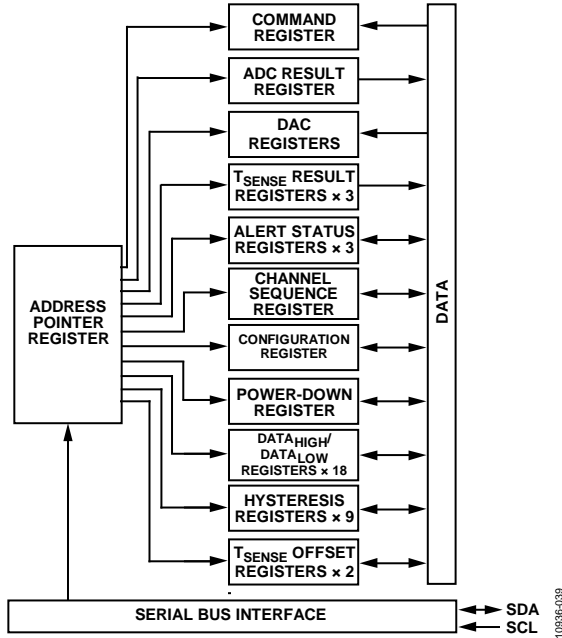

Figure 46. Register Structure

Each data register has an address to which the address pointer register points when communicating with it. The command register is the only register that is a write only register; the remainder of the addresses have both read and write access.

ADDRESS POINTER REGISTER

The address pointer register is an 8-bit register in which the six LSBs are used as pointer bits to store an address that points to one of the AD7294-2 data registers (see Table 9).

Table 9. Register Addresses

Address	Register Name	Access
0x00	Command register	W
0x01	ADC result register	R
	DAC _A value	W
0x02	T _{SENSE1} result	R
	DAC _B value	W
0x03	T _{SENSE2} result	R
	DAC _C value	W
0x04	T _{SENSEINT} result	R
	DAC _D value	W
0x05	Alert Status Register A	R/W
0x06	Alert Status Register B	R/W
0x07	Alert Status Register C	R/W
0x08	Channel sequence register	R/W
0x09	Configuration register	R/W
0x0A	Power-down register	R/W
0x0B	DATA _{LOW} Register V _{IN0}	R/W
0x0C	DATA _{HIGH} Register V _{IN0}	R/W
0x0D	Hysteresis Register V _{IN0}	R/W
0x0E	DATA _{LOW} Register V _{IN1}	R/W
0x0F	DATA _{HIGH} Register V _{IN1}	R/W
0x10	Hysteresis Register V _{IN1}	R/W
0x11	DATA _{LOW} Register V _{IN2}	R/W
0x12	DATA _{HIGH} Register V _{IN2}	R/W
0x13	Hysteresis Register V _{IN2}	R/W
0x14	DATA _{LOW} Register V _{IN3}	R/W
0x15	DATA _{HIGH} Register V _{IN3}	R/W
0x16	Hysteresis Register V _{IN3}	R/W
0x17	DATA _{LOW} Register I _{SENSE1}	R/W
0x18	DATA _{HIGH} Register I _{SENSE1}	R/W
0x19	Hysteresis Register I _{SENSE1}	R/W
0x1A	DATA _{LOW} Register I _{SENSE2}	R/W
0x1B	DATA _{HIGH} Register I _{SENSE2}	R/W
0x1C	Hysteresis Register I _{SENSE2}	R/W
0x1D	DATA _{LOW} Register T _{SENSE1}	R/W
0x1E	DATA _{HIGH} Register T _{SENSE1}	R/W
0x1F	Hysteresis Register T _{SENSE1}	R/W
0x20	DATA _{LOW} Register T _{SENSE2}	R/W
0x21	DATA _{HIGH} Register T _{SENSE2}	R/W
0x22	Hysteresis Register T _{SENSE2}	R/W
0x23	DATA _{LOW} Register T _{SENSEINT}	R/W
0x24	DATA _{HIGH} Register T _{SENSEINT}	R/W
0x25	Hysteresis Register T _{SENSEINT}	R/W
0x26	T _{SENSE1} offset register	R/W
0x27	T _{SENSE2} offset register	R/W
0x40	Factory test mode	N/A
0x41	Factory test mode	N/A

COMMAND REGISTER

A write to the command register (Address 0x00) puts the part into command mode. In command mode, the part cycles through the selected channels from LSB (Bit D0) to MSB (Bit D7) on each subsequent read (see Table 11). A channel is selected for conversion if a 1 is written to the desired bit in the command register. On power-up, all bits in the command register are set to 0. If the external T_{SENSE} channels are selected in the command register byte, it is not actually requesting a conversion. The result of the last automatic conversion is output as part of the sequence (see the Modes of Operation section).

If a command mode conversion is required while the autcycle mode is active, it is necessary to disable the autcycle mode before proceeding to the command mode (see the Autocycle Mode section for more details).

ADC RESULT REGISTER

The ADC result register (Address 0x01) is a 16-bit, read only register. The conversion results for the four uncommitted ADC inputs and the two I_{SENSE} channels are stored in the result register for reading.

Bit D14 to Bit D12 are the channel allocation bits, each of which identifies the ADC channel that corresponds to the subsequent result (see the ADC Channel Allocation section). Bit D11 to Bit D0 contain the most recent ADC result.

Table 11. Command Register¹

MSB							LSB	
Bits	D7	D6	D5	D4	D3	D2	D1	D0
Channel Name	Read out last result from T_{SENSE2}	Read out last result from T_{SENSE1}	I_{SENSE2}	I_{SENSE1}	V_{IN3} (S.E.) or $V_{IN3} - V_{IN2}$ (DIFF)	V_{IN2} (S.E.) or $V_{IN2} - V_{IN3}$ (DIFF)	V_{IN1} (S.E.) or $V_{IN1} - V_{IN0}$ (DIFF)	V_{IN0} (S.E.) or $V_{IN0} - V_{IN1}$ (DIFF)

¹ S.E. indicates single-ended, and DIFF indicates differential.

Table 12. ADC Result Register (First Read)

MSB						LSB	
D15	D14	D13	D12	D11	D10	D9	D8
ALERT_FLAG	CH_{ID2}	CH_{ID1}	CH_{ID0}	B11	B10	B9	B8

Table 13. ADC Result Register (Second Read)

MSB							LSB
D7	D6	D5	D4	D3	D2	D1	D0
B7	B6	B5	B4	B3	B2	B1	B0

Bit D15 is reserved as an ALERT_FLAG bit. Table 12 lists the contents of the first byte that is read from the AD7294-2 results register; Table 13 lists the contents of the second byte read.

ADC Channel Allocation

The three channel address bits indicate which channel the result in the result register represents. Table 10 describes the channel ID bits (S.E. indicates single-ended, and DIFF indicates differential).

Table 10. ADC Channel Allocation

Function	Channel ID		
	CH_{ID2}	CH_{ID1}	CH_{ID0}
V_{IN0} (S.E.) or $V_{IN0} - V_{IN1}$ (DIFF)	0	0	0
V_{IN1} (S.E.) or $V_{IN1} - V_{IN0}$ (DIFF)	0	0	1
V_{IN2} (S.E.) or $V_{IN2} - V_{IN3}$ (DIFF)	0	1	0
V_{IN3} (S.E.) or $V_{IN3} - V_{IN2}$ (DIFF)	0	1	1
I_{SENSE1}	1	0	0
I_{SENSE2}	1	0	1
T_{SENSE1}	1	1	0
T_{SENSE2}	1	1	1

T_{SENSE1} AND T_{SENSE2} RESULT REGISTERS

The T_{SENSE1} result register (Address 0x02) and T_{SENSE2} result register (Address 0x03) are 16-bit, read only registers. The MSB, Bit D15, is the ALERT_FLAG bit; Bits[D14:D12] contain the three ADC channel allocation bits. Bit D11 is reserved for flagging diode open circuits. Bits[D10:D0] store the temperature reading from the ADC in an 11-bit, twos complement format (see Table 14 and Table 15). Conversions take place approximately every 5 ms.

Table 14. T_{SENSEX} Result Register (First Read)

MSB							LSB
D15	D14	D13	D12	D11	D10	D9	D8
ALERT_FLAG	CH _{ID2}	CH _{ID1}	CH _{ID0}	B11	B10	B9	B8

Table 15. T_{SENSEX} Result Register (Second Read)

MSB							LSB
D7	D6	D5	D4	D3	D2	D1	D0
B7	B6	B5	B4	B3	B2	B1	B0

T_{SENSEINT} RESULT REGISTER

The T_{SENSEINT} result register (Address 0x04) is a 16-bit, read only register used to store the ADC data generated from the internal temperature sensor. Similar to the T_{SENSE1} and T_{SENSE2} result registers, this register stores the temperature readings from the ADC in an 11-bit, twos complement format (D10 to D0) and uses the MSB as a general alert flag. Bits[D14:D11] are not used

Table 18. T_{SENSEINT} Data Format

Input	D10 (MSB)	D9	D8	D7	D6	D5	D4	D3	D2	D1	D0 (LSB)
Value (°C)	-256	+128	+64	+32	+16	+8	+4	+2	+1	+0.5	+0.25

and are set to zero. Conversions take place approximately every 5 ms. The temperature data format in Table 18 applies to the internal temperature sensor data.

Temperature Value Format

The temperature reading from the ADC is stored in an 11-bit twos complement format, D10 to D0, to accommodate both positive and negative temperature measurements. The temperature data format is provided in Table 18.

DAC_A, DAC_B, DAC_C, AND DAC_D VALUE REGISTERS

Writing to Address 0x01 to Address 0x04 sets the DAC_A, DAC_B, DAC_C, and DAC_D output voltage codes, respectively. Bits[D11:D0] in the write result register are the data bits sent to DAC_A. Note that Bits[D15:D12] are ignored.

Table 16. DAC Register (First Write)¹

MSB							LSB
D15	D14	D13	D12	D11	D10	D9	D8
X	X	X	X	B11	B10	B9	B8

¹ X is don't care.

Table 17. DAC Register (Second Write)

MSB							LSB
D7	D6	D5	D4	D3	D2	D1	D0
B7	B6	B5	B4	B3	B2	B1	B0

ALERT STATUS REGISTER A, ALERT STATUS REGISTER B, AND ALERT STATUS REGISTER C

Alert Status Register A (Address 0x05), Alert Status Register B (Address 0x06), and Alert Status Register C (Address 0x07) are 8-bit, read/write registers that provide information about an alert event. If a conversion results in activation of the ALERT/BUSY pin or the ALERT_FLAG bit in the ADC result register or the T_{SENSEX} result registers, the alert status registers can be read to gain more information. To clear the full content of any alert status registers, write a code of 0xFF (all 1s) to the relevant register. Alternatively, write to the respective alert bit in the selected alert status register to clear the alert that is associated with that bit.

The entire contents of all the alert status registers can be cleared by writing a 1 to Bit D1 and Bit D2 in the configuration register, as shown in Table 24. However, this operation then enables the ALERT/BUSY pin for subsequent conversions. See the Alerts and Limits Theory section for more information.

CHANNEL SEQUENCE REGISTER

The channel sequence register (Address 0x08) is an 8-bit, read/write register that allows the user to sequence the ADC conversions to be performed in autocode mode. Table 22 shows the contents of the channel sequence register. See the Modes of Operation section for more information.

Table 19. Alert Status Register A

Alert Bit	D7	D6	D5	D4	D3	D2	D1	D0
Function	V _{IN3} high alert	V _{IN3} low alert	V _{IN2} high alert	V _{IN2} low alert	V _{IN1} high alert	V _{IN1} low alert	V _{IN0} high alert	V _{IN0} low alert

Table 20. Alert Status Register B

Alert Bit	D7	D6	D5	D4	D3	D2	D1	D0
Function	Reserved	Reserved	I _{SENSE2} overrange	I _{SENSE1} overrange	I _{SENSE2} high alert	I _{SENSE2} low alert	I _{SENSE1} high alert	I _{SENSE1} low alert

Table 21. Alert Status Register C

Alert Bit	D7	D6	D5	D4	D3	D2	D1	D0
Function	Open diode flag	Overtemp alert	T _{SENSEINT} high alert	T _{SENSEINT} low alert	T _{SENSE2} high alert	T _{SENSE2} low alert	T _{SENSE1} high alert	T _{SENSE1} low alert

Table 22. Channel Sequence Register

Channel Bit	D7	D6	D5	D4	D3	D2	D1	D0
Function	Reserved	Reserved	I _{SENSE2}	I _{SENSE1}	V _{IN3}	V _{IN2}	V _{IN1}	V _{IN0}

CONFIGURATION REGISTER

The configuration register (Address 0x09) is a 16-bit, read/write register that sets the operating mode of the AD7294-2. The bit functions of the configuration register are outlined in Table 23 and Table 24. On power-up, the configuration register is reset to 0x0000.

Sample Delay and Bit Trial Delay

It is recommended that no I²C bus activity occur when a conversion is taking place; however, this may not be possible, for example, when operating in autcycle mode. Bit D14 and Bit D13 in the configuration register are used to delay critical sample intervals and bit trials from occurring while there is activity on the I²C bus. On power-up, Bit D14 (noise-delayed sampling), Bit D13 (noise-delayed bit trials), and Bit D3 (I²C filters) are enabled (set to 0). This configuration is appropriate for low frequency applications because the bit trials are prevented from

occurring when there is activity on the I²C bus, thereby ensuring good dc linearity performance. For high frequency input signals, it may be desirable to have a known sampling point; thus, the noise-delayed sampling can be disabled by writing 1 to Bit D14 in the configuration register. This ensures that the sampling instance is fixed relative to SDA, resulting in improved SNR performance. If noise-delay samplings extend longer than 1 μ s, the current conversion terminates. This termination can occur if there are edges on SDA that are outside the I²C specification. When noise-delayed sampling is enabled, the rise and fall times must meet the I²C-specified standard. When Bit D13 is enabled, the conversion time may vary.

The default configuration for Bit D3 (enabled) is recommended for normal operation because it ensures that the I²C requirements for t_{OF} (minimum) and t_{SP} are met. The I²C filters reject glitches of less than 50 ns. If this function is disabled, the conversion results are more susceptible to noise from the I²C bus.

Table 23. Configuration Register Bit Function Descriptions, Bits[D15:D8]

Channel Bit	D15	D14	D13	D12	D11	D10	D9	D8
Function	Reserved	Noise-delayed sampling. Use to delay critical sample intervals from occurring when there is activity on the I ² C bus.	Noise-delayed bit trials. Use to delay critical bit trials from taking place when there is activity on the I ² C bus.	Autocycle mode	Pseudo differential mode for V_{IN2}/V_{IN3}	Pseudo differential mode for V_{IN0}/V_{IN1}	Differential mode for V_{IN2}/V_{IN3}	Differential mode for V_{IN0}/V_{IN1}
Setting		Enabled = 0 Disabled = 1	Enabled = 0 Disabled = 1	Enabled = 1 Disabled = 0	Enabled = 1 Disabled = 0	Enabled = 1 Disabled = 0	Enabled = 1 Disabled = 0	Enabled = 1 Disabled = 0

Table 24. Configuration Register Bit Function Descriptions, Bits[D7:D0]

Channel Bit	D7	D6	D5	D4	D3	D2	D1	D0
Function	$2 \times V_{REF}$ range for V_{IN3}	$2 \times V_{REF}$ range for V_{IN2}	$2 \times V_{REF}$ range for V_{IN1}	$2 \times V_{REF}$ range for V_{IN0}	I ² C filters	ALERT pin	BUSY pin (D2 = 0), clear alerts (D2 = 1)	Select ALERT pin polarity (active high/active low)
Setting	Enabled = 1 Disabled = 0	Enabled = 1 Disabled = 0	Enabled = 1 Disabled = 0	Enabled = 1 Disabled = 0	Enabled = 0 Disabled = 1	Enabled D2 = 1 D1 = 0 Disabled D2 = 0	Enabled D1 = 1 + D0 = 0 Disabled D1 = 0	Active high = 1 Active low = 0

Table 25. ALERT/BUSY Pin Function Descriptions

D2	D1	ALERT/BUSY Pin Function Descriptions
0	0	Pin does not provide any interrupt signal.
0	1	Configures pin as a busy output.
1	0	Configures pin as an alert output.
1	1	Resets the ALERT/BUSY output pin, the ALERT_FLAG bit in the conversion result register, and the entire alert status register (if any is active). 11 is written to Bits[D2:D1] in the configuration register to reset the ALERT/BUSY pin, the ALERT_FLAG bit, and the alert status register. Following this write, the content of the configuration register read 10 for Bit D2 and Bit D1, respectively, when read back.

Table 26. ADC Input Mode Examples

D11	D10	D9	D8	Description
0	0	0	0	All channels single-ended
0	0	0	1	Differential mode on V_{IN0}/V_{IN1}
0	1	0	1	Pseudo differential mode on V_{IN0}/V_{IN1}

POWER-DOWN REGISTER

The power-down register (Address 0x0A) is an 8-bit, read/write register that powers down various sections of the AD7294-2 device. On power-up, the default value for the power-down register is 0x70. The content of the power-down register is listed in Table 27.

Table 27. Power-Down Register Bit Descriptions

Bit	Description
D7	Powers down the ADC and DAC reference buffers and the temperature sensor. Sets the DAC outputs to high impedance and disables the I _{SENSE1} and I _{SENSE2} alerts.
D6	Reserved.
D5	Powers down the ADC reference buffer. To allow for an external reference, set to 1 at power-up.
D4	Powers down the DAC reference buffer. To allow for an external reference, set to 1 at power-up.
D3	Powers down the temperature sensor.
D2	Disables the I _{SENSE1} alerts.
D1	Disables the I _{SENSE2} alerts.
D0	Sets the DAC outputs to high impedance.

DATA_{LOW} AND DATA_{HIGH} REGISTERS

V_{IN0} to V_{IN3} Channels

The DATA_{LOW} and DATA_{HIGH} registers (Address 0x0B and Address 0x0C, V_{IN0}; Address 0x0E and Address 0x0F, V_{IN1}; Address 0x11 and Address 0x12, V_{IN2}; Address 0x14 and Address 0x15, V_{IN3}), one pair for each V_{INx} channel, are 16-bit, read/write registers (see Table 29 and Table 30). General alert is flagged by the MSB, Bit D15. Bits[D14:D12] are not used in the register and are set to 0. The remaining 12 bits set the low and high limits for the relevant channel. For single-ended mode, the default values for V_{IN0} to V_{IN3} are 0x000 (DATA_{LOW}) and 0xFFFF (DATA_{HIGH}) in binary format. For differential mode, the default values for V_{IN0} to V_{IN3} are 0x800 (DATA_{LOW}) and 0x7FF (DATA_{HIGH}) in twos complement format. Note that, if the part is configured in either single-ended or differential mode and the mode is changed, the limits in the DATA_{LOW} and DATA_{HIGH} registers must be reprogrammed.

T_{SENSE1}, T_{SENSE2}, and T_{SENSEINT} Channels

Channel 7 to Channel 9 (Address 0x1D and Address 0x1E, T_{SENSE1}; Address 0x20 and Address 0x21, T_{SENSE2}; and Address 0x23 and Address 0x24, T_{SENSEINT}) default to 0x400 (DATA_{LOW}) and 0x3FF (DATA_{HIGH}) as the limits because they are in 11-bit, twos complement format.

Table 28. Default Values for DATA_{LOW} and DATA_{HIGH} Registers

ADC Channel	Single-Ended		Differential	
	DATA _{LOW}	DATA _{HIGH}	DATA _{LOW}	DATA _{HIGH}
V _{IN0}	0x000	0xFFFF	0x800	0x7FF
V _{IN1}	0x000	0xFFFF	0x800	0x7FF
V _{IN2}	0x000	0xFFFF	0x800	0x7FF
V _{IN3}	0x000	0xFFFF	0x800	0x7FF
I _{SENSE1}	N/A	N/A	0x800	0x7FF
I _{SENSE2}	N/A	N/A	0x800	0x7FF
T _{SENSE1}	N/A	N/A	0x400	0x3FF
T _{SENSE2}	N/A	N/A	0x400	0x3FF
T _{SENSEINT}	N/A	N/A	0x400	0x3FF

Table 29. DATA_{LOW}, DATA_{HIGH} Register (First Read/Write)

MSB				LSB			
D15	D14	D13	D12	D11	D10	D9	D8
ALERT_FLAG	0	0	0	B11	B10	B9	B8

Table 30. DATA_{LOW}, DATA_{HIGH} Register (Second Read/Write)

MSB				LSB			
D7	D6	D5	D4	D3	D2	D1	D0
B7	B6	B5	B4	B3	B2	B1	B0

HYSTERESIS REGISTERS

Each hysteresis register (Address 0x0D, V_{IN0}; Address 0x10, V_{IN1}; Address 0x13, V_{IN2}; Address 0x16, V_{IN3}; Address 0x19, I_{SENSE1}; Address 0x1C, I_{SENSE2}; Address 0x1F, T_{SENSE1}; Address 0x22, T_{SENSE2}; Address 0x25, T_{SENSEINT}) is a 16-bit, read/write register in which only the 12 LSBs of the register are used. The MSB signals the alert event. If 0xFFFF is written to the hysteresis register, the hysteresis register enters the minimum/maximum mode (see the Alerts and Limits Theory section).

Table 31. Hysteresis Register (First Read/Write)

MSB				LSB			
D15	D14	D13	D12	D11	D10	D9	D8
ALERT_FLAG	0	0	0	B11	B10	B9	B8

Table 32. Hysteresis Register (Second Read/Write)

MSB				LSB			
D7	D6	D5	D4	D3	D2	D1	D0
B7	B6	B5	B4	B3	B2	B1	B0

REMOTE CHANNEL T_{SENSE1} AND T_{SENSE2} OFFSET REGISTERS

The T_{SENSE1} offset register (Address 0x26) and T_{SENSE2} offset register (Address 0x27) allow the user to add or subtract an offset to the temperature. These 8-bit, read/write registers store data in a twos complement format. The data is subtracted from the temperature readings taken by the T_{SENSE1} and T_{SENSE2} temperature sensors. The offset is implemented before the values are stored in the T_{SENSE1} and T_{SENSE2} result registers.

The offset registers can be used to compensate for transistors with different ideality factors because the T_{SENSEX} results are based on the 2N3906 transistor ideality factor. Different transistors with different ideality factors result in different offsets within the region of interest, which can be compensated for by using this register.

Table 33. T_{SENSE1}, T_{SENSE2} Offset Register Data Format

Input	MSB D7	D6	D5	D4	D3	D2	D1	LSB D0
Value (°C)	-32	+16	+8	+4	+2	+1	+0.5	+0.25

I²C INTERFACE

GENERAL I²C TIMING

Figure 47 shows the timing for general read and write operations using an I²C-compliant interface. The I²C bus uses open-drain drivers; therefore, when no device is driving the bus, both SCL and SDA are high. This is known as idle state. When the bus is idle, the master initiates a data transfer by establishing a start condition, defined as a high-to-low transition on the serial data line (SDA) while the serial clock line (SCL) remains high. This indicates that a data stream follows. The master device is responsible for generating the clock.

Data is sent over the serial bus in groups of nine bits: eight bits of data from the transmitter followed by an acknowledge bit (ACK) from the receiver. Data transitions on the SDA line must occur during the low period of the clock signal and remain stable during the high period. The receiver should pull the SDA line low during the acknowledge bit to signal that the preceding byte has been received correctly. If this is not the case, cancel the transaction.

The first byte that the master sends must consist of a 7-bit slave address, followed by a data direction bit. Each device on the bus has a unique slave address; therefore, the first byte sets up communication with a single slave device for the duration of the transaction.

The transaction can be used either to write to a slave device (data direction bit = 0) or to read data from it (data direction bit = 1). In the case of a read transaction, it is often necessary first to write to the slave device (in a separate write transaction) to tell it from which register to read. Reading and writing cannot be combined in one transaction.

When the transaction is complete, the master can keep control of the bus, initiating a new transaction by generating another start bit (high-to-low transition on SDA while SCL is high). This is known as a repeated start (Sr). Alternatively, the bus can be relinquished by releasing the SCL line followed by releasing the SDA line. This low-to-high transition on SDA while SCL is high is known as a stop bit (P), and it leaves the I²C bus in its idle state (that is, no current is consumed by the bus).

The example in Figure 47 shows a simple write transaction with an AD7294-2 as the slave device. In this example, the AD7294-2 register pointer is being readied for a future read transaction.

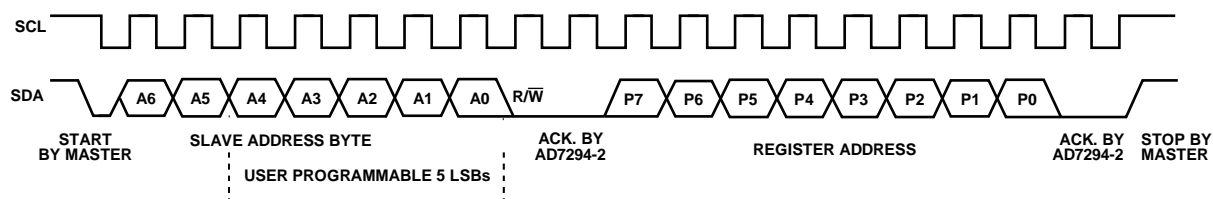

Figure 47. General I²C Timing

SERIAL BUS ADDRESS BYTE

The first byte the user writes to the device is the slave address byte. Similar to all I²C-compatible devices, the AD7294-2 has a 7-bit serial address. The five LSBs are user-programmable via the three, three-state input pins, as shown in Table 34.

Table 34 shows that the ASx pins are sometimes left floating. Note that, in such cases, the stray capacitance on the pin must be less than 30 pF to allow correct detection of the floating state; therefore, any PCB trace must be kept as short as possible.

Table 34. Slave Address Control Using Three-State Input Pins¹

AS2	AS1	AS0	Slave Address (A6 to A0)
L	L	L	0x61
L	L	H	0x62
L	L	NC	0x63
L	H	L	0x64
L	H	H	0x65
L	H	NC	0x66
L	NC	L	0x67
L	NC	H	0x68
L	NC	NC	0x69
H	L	L	0x6A
H	L	H	0x6B
H	L	NC	0x6C
H	H	L	0x6D
H	H	H	0x6E
H	H	NC	0x6F
H	NC	L	0x70
H	NC	H	0x71
H	NC	NC	0x72
NC	L	L	0x73
NC	L	H	0x74
NC	L	NC	0x75
NC	H	L	0x76
NC	H	H	0x77
NC	H	NC	0x78
NC	NC	L	0x79
NC	NC	H	0x7A
NC	NC	NC	0x7B

¹ H = tie the pin to V_{DRIVE}, L = tie the pin to DGND, NC = pin left floating.

Reading Data from an 8-Bit Register

Reading the contents from any of the 8-bit registers is a single-byte read operation, as shown in Figure 51. In this protocol, the first part of the transaction writes to the register pointer. When the register address has been set up, any number of reads can be performed from that particular register address without having to write to the address pointer register again. When the required number of reads is completed, the master should not acknowledge the final byte. This tells the slave to stop transmitting, allowing a stop condition to be asserted by the master. Additional reads from this register can be performed in a future transaction without the need to rewrite to the register pointer.

If a read from a different address is required, the relevant register address must be written to the address pointer register. Again, any number of reads from this register can then be performed. In the next example, the master device receives two bytes from a slave device, as follows:

1. The master device asserts a start condition on SDA.
2. The master sends the 7-bit slave address followed by the read bit (high).
3. The addressed slave device asserts an acknowledge on SDA.
4. The master receives a data byte.
5. The master asserts an acknowledge on SDA.
6. The master receives another 8-bit data byte.
7. The master asserts a no acknowledge on SDA to inform the slave that the data transfer is complete.
8. The master asserts a stop condition on SDA to end the transaction.

Reading Two Bytes of Data from a 16-Bit Register

In this example, the master device reads three lots of two-byte data from a slave device (see Figure 52). However, any number of lots consisting of two bytes can be read. This protocol assumes that the particular register address has been set up by a single-byte write operation to the address pointer register (see the previous read example).

1. The master device asserts a start condition on SDA.
2. The master sends the 7-bit slave address followed by the read bit (high).
3. The addressed slave device asserts an acknowledge on SDA.
4. The master receives the data byte.
5. The master asserts an acknowledge on SDA.
6. The master receives a second data byte.
7. The master asserts an acknowledge on SDA.
8. The master receives a data byte.
9. The master asserts an acknowledge on SDA.
10. The master receives a second data byte.
11. The master asserts an acknowledge on SDA.
12. The master receives a data byte.
13. The master asserts an acknowledge on SDA.
14. The master receives a second data byte.
15. The master asserts a no acknowledge on SDA to notify the slave that the data transfer is complete.
16. The master asserts a stop condition on SDA to end the transaction.

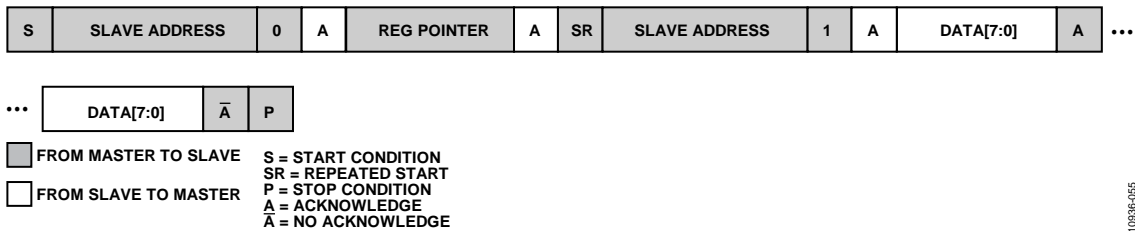

Figure 51. Reading Two Single Bytes of Data from a Selected Register

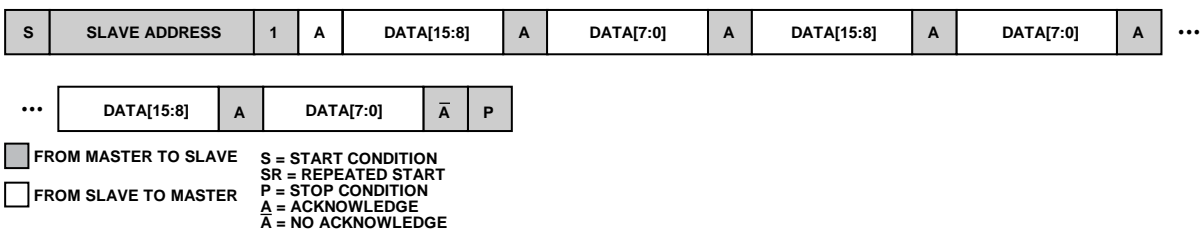

Figure 52. Reading Three Lots of Two Bytes of Data from the Conversion Result Register

MODES OF OPERATION

There are two different methods of initiating a conversion on the AD7294-2: command mode and autcycle mode.

COMMAND MODE

In command mode, the AD7294-2 ADC converts on demand on either a single channel or a sequence of channels. To enter this mode, the required combination of channels is written into the command register (Address 0x00). The first conversion takes place at the end of this write operation, in time for the result to be read out in the next read operation. While this result is being read out, the next conversion in the sequence takes place, and so on.

To exit the command mode, the master does not acknowledge the final byte of data. This stops the AD7294-2 from transmitting, allowing the master to assert a stop condition on the bus. When switching to read mode, therefore, it is important that, after writing to the command register, a repeated start (Sr) signal be used rather than a stop (P) followed by a start (S). Otherwise, the device exits command mode after the first conversion.

After writing to the command register, the register pointer is returned to its previous value. If a new pointer value is required (typically for the ADC result register, Address 0x01), it can be written immediately following the command byte. This extra write operation does not affect the conversion sequence because the second conversion is triggered only at the start of the first read operation.

The maximum throughput that can be achieved using this mode with a 400 kHz I²C clock is (400 kHz/18) = 22.2 kSPS.

Figure 53 shows the command mode converting on a sequence of channels including V_{IN0}, V_{IN1}, and I_{SENSE1}.

The conversion sequence is as follows:

1. The master device asserts a start condition on SDA.
2. The master sends the 7-bit slave address followed by the write bit (low).
3. The addressed slave device (AD7294-2) asserts an acknowledge on SDA.
4. The master sends the command register address (0x00). The slave asserts an acknowledge on SDA.
5. The master sends Data Byte 0x13, which selects the V_{IN0}, V_{IN1}, and I_{SENSE1} channels.
6. The slave asserts an acknowledge on SDA.
7. The master sends the ADC result register address (0x01). The slave asserts an acknowledge on SDA.
8. The master sends the 7-bit slave address followed by the write bit (high).
9. The slave (AD7294-2) asserts an acknowledge on SDA.
10. The master receives a data byte, which contains the ALERT_FLAG bit, the channel ID bits, and the four MSBs of the conversion result for the V_{IN0} channel. The master then asserts an acknowledge on SDA.
11. The master receives the second data byte, which contains the eight LSBs of the converted result for the V_{IN0} channel. The master then asserts an acknowledge on SDA.
12. Step 10 and Step 11 are repeated for the V_{IN1} channel and the I_{SENSE1} channel.
13. When the master receives the results from all the selected channels, the slave again converts and outputs the result for the first channel in the selected sequence. Step 10 to Step 12 are repeated.
14. The master asserts a no acknowledge on SDA and a stop condition on SDA to end the conversion and exit command mode.

If no read occurs in a 5 ms period, the AD7294-2 automatically exits command mode. To change the conversion sequence, write a new sequence to the command register.

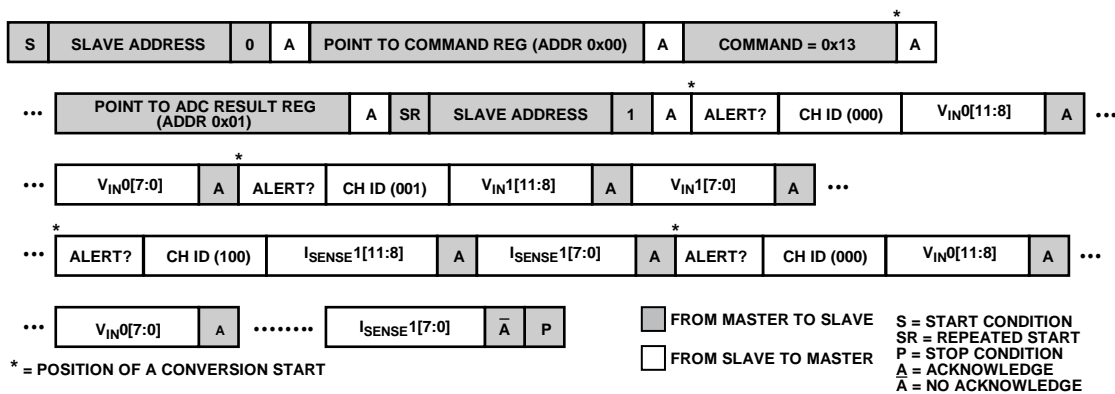

Figure 53. Command Mode Operation

AUTOCYCLE MODE

The AD7294-2 can be configured to convert continuously on a programmable sequence of channels, making it the ideal mode of operation for system monitoring. These conversions occur in the background approximately every 50 μ s and are transparent to the master. Typically, this mode is used to automatically monitor a selection of channels with either the limit registers programmed to signal an out-of-range condition via the alert function or the minimum/maximum recorders tracking the variation over time of a particular channel. Reads and writes can be performed at any time (the ADC result register, Address 0x01, contains the most recent conversion result).

On power-up, the autocycle mode is disabled. To enable it, write to Bit D12 in the configuration register (Address 0x09) and select the desired channels for conversion in the channel sequence register (Address 0x08).

If a command mode conversion is required while the autocycle mode is active, it is necessary to disable the autocycle mode before proceeding to the command mode. This is achieved either by clearing Bit D12 of the configuration register or by writing 0x00 to the channel sequence register. When the command mode conversion is complete, the user must exit command mode by issuing a stop condition before reenabling autocycle mode.

When switching from autocycle mode to command mode, the temperature sensor must be given sufficient time to settle and complete a new temperature integration cycle. Therefore, temperature sensor conversions performed within the first 500 ms after switching from autocycle mode to command mode may trigger false temperature high and low alarms. It is recommended that the temperature sensor alarms be disabled for the first 500 ms after mode switching by writing 0x400 to the DATA_{LOW} register T_{SENSEX} and 0x3FF to the DATA_{HIGH} register T_{SENSEX}. Reconfigure the temperature sensor alerts to the desired alarm level when the 500 ms period has elapsed. Alternatively, ignore any temperature alerts triggered during the first 500 ms after mode switching.

ALERTS AND LIMITS THEORY

ALERT_FLAG BIT

The ALERT_FLAG bit indicates whether the conversion result being read or any other channel result has violated the limit registers associated with it. If an alert occurs and the ALERT_FLAG bit is set, the master can read the alert status register to obtain more information on where the alert occurred.

ALERT STATUS REGISTERS

The alert status registers are 8-bit, read/write registers that provide information on an alert event. If a conversion results in activation of the ALERT/BUSY pin or the ALERT_FLAG bit in the ADC result register or T_{SENSE} result registers, the alert status register can be read to get more information (see Figure 54 for the alert register structure).

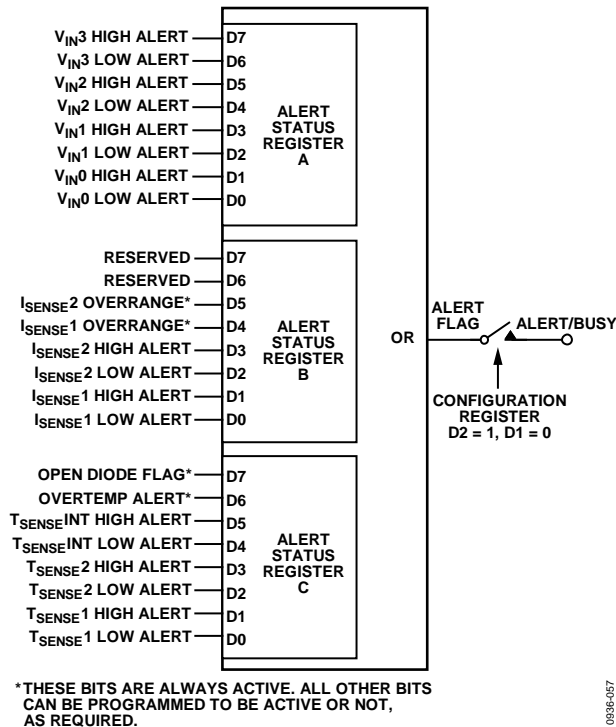

Figure 54. Alert Status Register Structure

Alert Status Register A (see Table 19) consists of four channels with two status bits per channel, one bit corresponding to each of the DATA_{LOW} and DATA_{HIGH} limits. This register stores the alert event data for V_{IN3} to V_{IN0}, which are the standard voltage inputs. When the contents of this register are read, any bit with a status of 1 indicates a violation of its associated limit; that is, it identifies the channel and whether the violation occurred on the upper or lower limit. If a second alert event occurs on another channel before the contents of the alert register are read, the bit corresponding to the second alert event is also set.

Alert Status Register B (see Table 20) consists of three channels, also with two status bits per channel, representing the specified DATA_{LOW} and DATA_{HIGH} limits. Bits[D3:D0] correspond to the low and high limit alerts for the current sense inputs.

Bit D4 and Bit D5 represent the I_{SENSE1} OVERRANGE and I_{SENSE2} OVERRANGE values of V_{REF}/10.41. During power-up, it is possible for the fault outputs to be triggered, depending on which supply comes up first. It is recommended that these bits be cleared on power-up as part of the initialization routine by writing a 1 to both D4 and D5.

The AD7294-2 internal circuitry can generate an alert if either the D1(±) or the D2(±) input pins for the external temperature sensor are open circuit. The most significant bit (MSB) of Alert Status Register C (see Table 21) alerts the user when an open diode flag occurs on the external temperature sensors. If the internal temperature sensor detects an AD7294-2 die temperature of greater than 150°C, the overtemperature alert bit (Bit D6 in Alert Status Register C) is set, and the DAC outputs are set to a high impedance state. The remaining six bits in Address 0x06 store alert event data for T_{SENSE_INT}, T_{SENSE2}, and T_{SENSE1} with two status bits per channel, one corresponding to each of the DATA_{HIGH} and DATA_{LOW} limits.

To clear the full contents of any alert register, write a code of 0xFF (all 1s) to the relevant registers. Alternatively, the user can write to the respective alert bit in the selected alert register to clear the alert that is associated with that bit. The entire contents of all the alert status registers can be cleared by writing a 1 to Bit D2 and Bit D1 in the configuration register, as shown in Table 24. However, this operation then enables the ALERT/BUSY pin for subsequent conversions.

DATA_{LOW} AND DATA_{HIGH} MONITORING FEATURES

If the result moves outside the lower or upper limit set by the user, the AD7294-2 signals an alert using hardware (via the ALERT/BUSY pin), software (via the ALERT_FLAG bit), or both, depending on the configuration.

The DATA_{LOW} register stores the lower limit that activates the ALERT/BUSY output pin and/or the ALERT_FLAG bit in the conversion result register. If the conversion result is less than the value in the DATA_{LOW} register, an alert occurs. The DATA_{HIGH} register stores the upper limit that activates the ALERT/BUSY output pin and/or the ALERT_FLAG bit in the conversion result register. If the conversion result is greater than the value in the DATA_{HIGH} register, an alert occurs.

An alert associated with either the DATA_{LOW} or DATA_{HIGH} register is cleared automatically when the monitored signal is back in range; that is, the conversion result is between the limits. The contents of the alert register are updated after each conversion. A conversion is performed every 50 μs in autocycle mode; as a result, the contents of the alert register may change every 50 μs. If the ALERT pin signals an alert event and the content of the alert register is not read before the next conversion is complete, the contents of the register may be changed if the signal that is being monitored returns between the specified limits. In such circumstances, the ALERT pin no longer signals the occurrence of an alert event.

The hysteresis register can be used to avoid flicker on the ALERT/BUSY pin. If the hysteresis function is enabled, the conversion result must return to a value of at least N LSBs above the DATA_{LOW} or N LSBs below the DATA_{HIGH} register value for the ALERT/BUSY output pin and ALERT_FLAG bit to be reset. The value of N is taken from the 12-bit hysteresis register associated with that channel. By setting the hysteresis register to a code that is close to the maximum output code for the ADC (for example, 0x77D), the DATA_{LOW} or DATA_{HIGH} alerts are not cleared automatically by the AD7294-2.

Bit D11 of DATA_{LOW} or DATA_{HIGH} Register T_{SENSEX} is the diode open circuit flag. If this bit is set to 0, it indicates the presence of an open circuit between the Dx(+) and Dx(-) pins. An alert that is triggered on either I_{SENSE} OVERRANGE pin remains until it is cleared by a write to the alert status register. The contents of the DATA_{LOW} and DATA_{HIGH} registers are reset to their default values on power-up (see Table 28).

HYSTERESIS

The hysteresis value determines the reset point for the ALERT/BUSY pin and/or ALERT_FLAG bit if a violation of the limits occurs. The hysteresis register stores the hysteresis value, N, when using the limit registers. Each pair of limit registers has a dedicated hysteresis register. For example, if a hysteresis value of

8 LSBs is required on the upper and lower limits of V_{IN0}, the 16-bit word, 0000 0000 0000 1000, should be written to Hysteresis Register VIN0 (Register 0x0D, see Table 9). On power-up, the hysteresis registers contain a value of 8 LSBs for nontemperature result registers and 8°C, or 32 LSBs, for the T_{SENSE} registers. If a different hysteresis value is required, that value must be written to the hysteresis register for the channel in question.

The advantage of having hysteresis registers associated with each of the limit registers is that hysteresis prevents chatter on the alert bits associated with each ADC channel. Figure 55 shows the limit checking operation.

Using the Limit Registers to Store Minimum/Maximum Conversion Results

If 0xFFF is written to the hysteresis register for a particular channel, the DATA_{LOW} and DATA_{HIGH} registers for that channel no longer act as limit registers, as previously described, but, instead, act as storage registers for the maximum and minimum conversion results. This function is useful when an alert signal is not required in an application, but it is still required to monitor the minimum and maximum conversion values over time. Note that on power-up, the contents of the DATA_{HIGH} register for each channel are set to the maximum code, whereas the contents of the DATA_{LOW} registers are set to the minimum code by default.

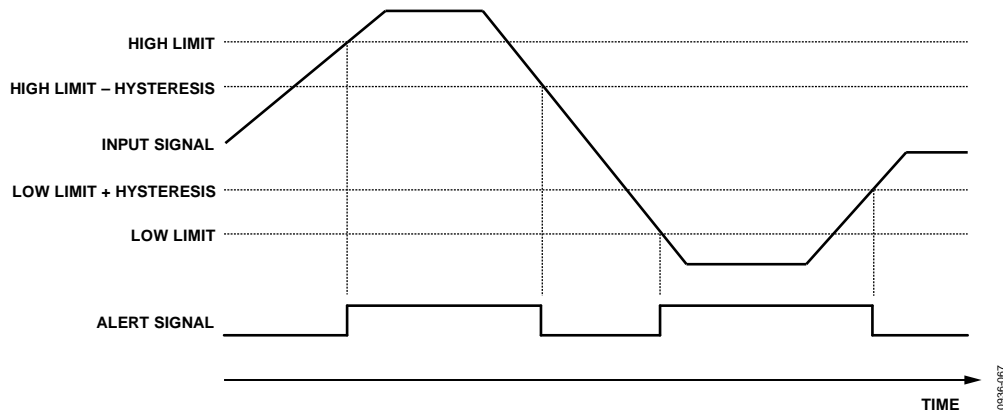

Figure 55. Limit Checking

APPLICATIONS INFORMATION

The AD7294-2 contains all the functions that are required for general-purpose monitoring and control of current, voltage, and temperature. With its 59.4 V maximum common-mode range, the device is useful in industrial and automotive applications where current sensing in the presence of a high common-mode voltage is required. For example, the part is ideally suited for monitoring and controlling a power amplifier in a cellular base station.

BASE STATION POWER AMPLIFIER MONITOR AND CONTROL

The AD7294-2 is used in a power amplifier signal chain to achieve the optimal bias condition for the LD MOS transistor. The main factors influencing the bias conditions are temperature, supply voltage, gate voltage drift, and general processing parameters. The overall performance of a power amplifier configuration is determined by the inherent trade-offs required in efficiency, gain, and linearity. The high level of integration offered by the AD7294-2 allows the use of a single chip to dynamically control the drain bias current to maintain a constant value over temperature and time, thus significantly improving the overall performance of the power amplifier. The AD7294-2 incorporates the functionality of eight discrete components, bringing considerable board area savings over alternative solutions.

The circuit in Figure 56 is a typical system connection diagram for the AD7294-2. The device monitors and controls the overall performance of two final stage amplifiers. The gain control and phase adjustment of the driver stage are incorporated in the application and are carried out by the two available uncommitted outputs of the AD7294-2. Both high-side current senses measure the amount of current on the respective final stage amplifiers. The comparator outputs, the I_{SENSE1} OVERRANGE and I_{SENSE2} OVERRANGE pins, are the controlling signals for the switches on the RF inputs of the LD MOS power FETs. If the high-side current sense reads a value above a specified limit compared with the setpoint, the RF IN signal is switched off by the comparator.

By measuring the transmitted power (Tx) and the received power (Rx), the device can dynamically change the drivers and PA signal to optimize performance. This application requires a logarithmic detector/controller, such as the Analog Devices AD8317 or AD8362.

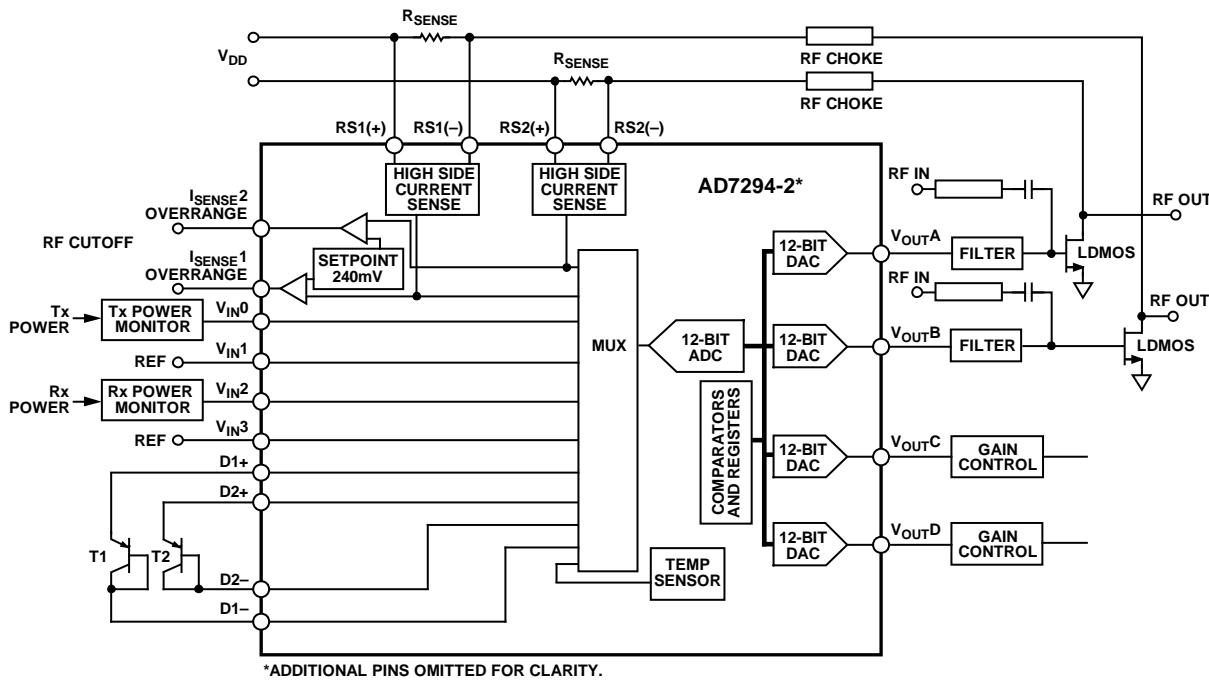

Figure 56. Typical HPA Monitor and Control Application

10836-036

GAIN CONTROL OF POWER AMPLIFIER

In gain control mode, a setpoint voltage that is proportional in decibels (dB) to the desired output power is applied to a power detector such as the AD8362. A sample of the output power from the power amplifier (PA), through a directional coupler and attenuator (or by other means), is fed to the input of the AD8362. The VOUT pin is connected to the gain control terminal of the PA (see Figure 57). Based on the defined relationship between VOUT and the RF input signal, the AD8362 adjusts the voltage on VOUT (VOUT is now an error amplifier output) until the level at the RF input corresponds to the applied VSET. The AD7294-2 completes a feedback loop that tracks the output of the AD8362 and adjusts the VSET input of the AD8362 accordingly.

The VOUT pin of the AD8362 is applied to the gain control terminal of the power amplifier. For this output power control loop to be stable, a ground referenced capacitor must be connected to the CLPF pin of the AD8362. This capacitor integrates the error signal (which is actually a current) that is present when the loop is not balanced. In a system where a variable gain amplifier (VGA) or variable voltage attenuator (VVA) feeds the power amplifier, only one AD8362 is required. In such a case, the gain on one of the parts (VVA, PA) is fixed, and VOUTX feeds the control input of the other.

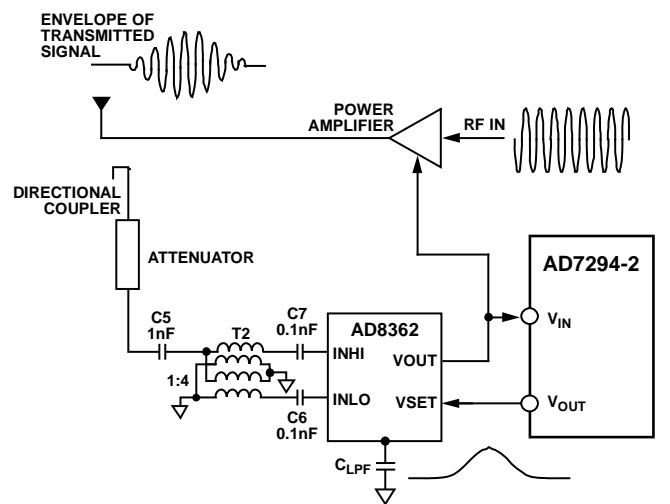
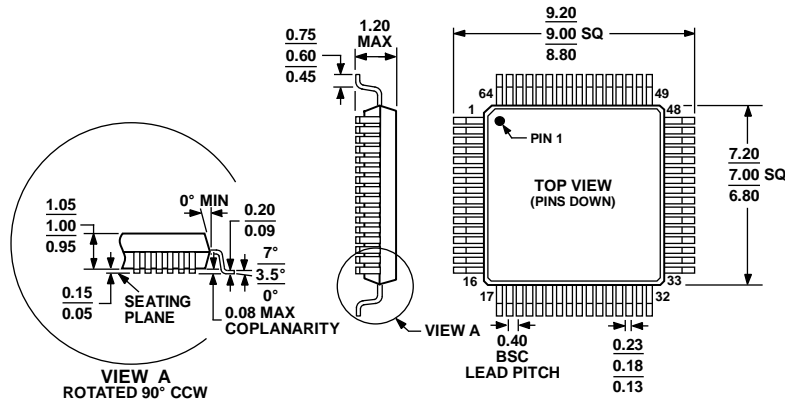

Figure 57. Setpoint Controller Operation

OUTLINE DIMENSIONS



COMPLIANT TO JEDEC STANDARDS MS-026-ABD

Figure 58. 64-Lead Thin Plastic Quad Flat Package [TQFP] (SU-64-1)

Dimensions shown in millimeters

012108-A

ORDERING GUIDE

Model ¹	Temperature Range	Package Description	Package Option
AD7294-2BSUZ	-40°C to +105°C	64-Lead Thin Plastic Quad Flat Package [TQFP]	SU-64-1
AD7294-2BSUZ-RL	-40°C to +105°C	64-Lead Thin Plastic Quad Flat Package [TQFP]	SU-64-1

¹ Z = RoHS Compliant Part.



NOTES

NOTES

I²C refers to a communications protocol originally developed by Philips Semiconductors (now NXP Semiconductors).

Looking for pricing, stock, or lifecycle information?

Click below to explore more details on WIN SOURCE:

-  [View AD7294-2BSUZ on WIN SOURCE](#)
-  [Analog Devices Inc. Information](#)

Optimize Your Supply Chain with WIN SOURCE Solutions

-  Global Sourcing Solution
-  Obsolete Management
-  Cost Control Management
-  Shortage Management
-  Alternative Solution
-  Excess Inventory Management