



**THE DATASHEET OF
DAC34SH84IZAYR**



DAC34SH84 Quad-Channel, 16-Bit, 1.5 GSPS Digital-to-Analog Converter (DAC)

1 Features

- Low Power: 1.8 W at 1.5 GSPS, Full Operating Condition
- Multi-DAC Synchronization
- Selectable 2x, 4x, 8x, 16x Interpolation Filter
 - Stop-Band Attenuation > 90 dBc
- Flexible On-Chip Complex Mixing
 - Two Independent Fine Mixers With 32-Bit NCOs
 - Power-Saving Coarse Mixers: $\pm n \times f_s / 8$
- High-Performance, Low-Jitter Clock-Multiplying PLL
- Digital I and Q Correction
 - Gain, Phase and Offset
- Digital Inverse Sinc Filters
- 32-Bit DDR Flexible LVDS Input Data Bus
 - 8-Sample Input FIFO
 - Supports Data Rates up to 750 MSPS
 - Data Pattern Checker
 - Parity Check
- Temperature Sensor
- Differential Scalable Output: 10 mA to 30 mA
- 196-Ball, 12-mm x 12-mm NFBGA

2 Applications

- Cellular Base Stations
- Diversity Transmit
- Wideband Communications

3 Description

The DAC34SH84 is a very low-power, high-dynamic range, quad-channel, 16-bit digital-to-analog converter (DAC) with a sample rate as high as 1.5 GSPS.

The device includes features that simplify the design of complex transmit architectures: 2x to 16x digital interpolation filters with over 90 dB of stop-band attenuation simplify the data interface and reconstruction filters. Independent complex mixers allow flexible carrier placement.

A high-performance low-jitter clock multiplier simplifies clocking of the device without significant impact on the dynamic range. The digital quadrature modulator correction (QMC) enables complete IQ compensation for gain, offset and phase between channels in direct upconversion applications.

Digital data is input to the device through a 32-bit wide LVDS data bus with on-chip termination. The wide bus allows the processing of high-bandwidth signals. The device includes a FIFO, data pattern checker, and parity test to ease the input interface. The interface also allows full synchronization of multiple devices.

The device is characterized for operation over the entire industrial temperature range of -40°C to 85°C and is available in a 196-ball, 12-mm x 12-mm, 0.8-mm pitch NFBGA package.

The DAC34SH84 low-power, high-bandwidth support, superior crosstalk, high dynamic range, and features are an ideal fit for next-generation communication systems.

Device Information⁽¹⁾

PART NUMBER	PACKAGE	BODY SIZE (NOM)
DAC34SH84	NFBGA (196)	12.00 mm x 12.00 mm

(1) For all available packages, see the orderable addendum at the end of the data sheet.

Simplified Schematic

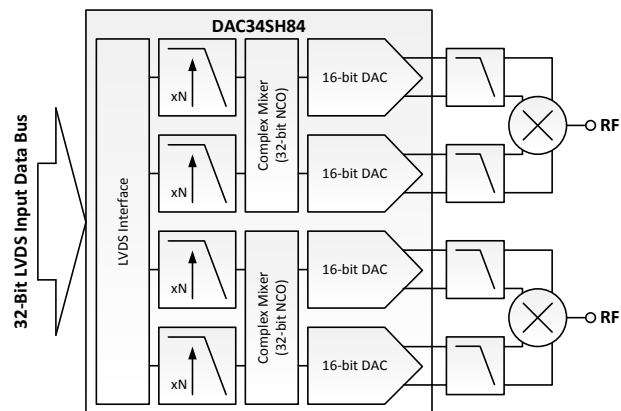

Table of Contents

1 Features	1	7.3 Feature Description.....	23
2 Applications	1	7.4 Device Functional Modes.....	49
3 Description	1	7.5 Programming	53
4 Revision History	2	7.6 Register Map.....	57
5 Pin Configuration and Functions	3	8 Application and Implementation	74
6 Specifications	6	8.1 Application Information.....	74
6.1 Absolute Maximum Ratings	6	8.2 Typical Applications	75
6.2 ESD Ratings.....	6	9 Power Supply Recommendations	81
6.3 Recommended Operating Conditions.....	7	10 Layout	82
6.4 Thermal Information	7	10.1 Layout Guidelines	82
6.5 Electrical Characteristics – DC Specifications	7	10.2 Layout Examples.....	83
6.6 Electrical Characteristics – Digital Specifications	9	11 Device and Documentation Support	86
6.7 Electrical Characteristics – AC Specifications	10	11.1 Device Support.....	86
6.8 Timing Requirements – Digital Specifications.....	11	11.2 Documentation Support	86
6.9 Switching Characteristics – AC Specifications.....	12	11.3 Community Resources.....	87
6.10 Typical Characteristics	13	11.4 Trademarks	87
7 Detailed Description	21	11.5 Electrostatic Discharge Caution.....	87
7.1 Overview	21	11.6 Glossary	87
7.2 Functional Block Diagram	22	12 Mechanical, Packaging, and Orderable Information	87

4 Revision History

Changes from Revision D (October 2012) to Revision E Page

- Added *ESD Ratings* table, *Feature Description* section, *Device Functional Modes*, *Application and Implementation* section, *Power Supply Recommendations* section, *Layout* section, *Device and Documentation Support* section, and *Mechanical, Packaging, and Orderable Information* section. **1**

Changes from Revision C (October 2012) to Revision D Page

- Changed from ADVANCE INFORMATION to PRODUCTION DATA

Changes from Revision B (July 2012) to Revision C Page

- Added Phase-Locked Loop section to Electrical Characteristics — Digital table..... **10**
- Revised the text in the Bypass Mode section
- Added reference to new PLL section in Electrical Characteristics – Digital table
- Added a sentence to the last paragraph in the Data Pattern Checker section
- Changed version register
- Changed contents of version register.....

Changes from Revision A (June 2012) to Revision B Page

- Added thermal information to the Absolute Maximum Ratings table
- Added Recommended Operating Conditions table
- Deleted OPERATING RANGE section from bottom of Electrical Characteristics - DC Specifications table
- Changed DAC Wake-up Time in Electrical Characteristics – AC Specifications

5 Pin Configuration and Functions

**ZAY Package
196-Pin NFBGA
Top View**

	A	B	C	D	E	F	G	H	J	K	L	M	N	P
14	GND	IOUT AP	IOUT AN	GND	IOUT BN	IOUT BP	GND	GND	IOUT CP	IOUT CN	GND	IOUT DN	IOUT DP	GND
13	GND	GND	GND	GND	GND	GND	GND	GND	GND	GND	GND	GND	GND	GND
12	DAC CLKP	GND	CLK VDD	LPF	GND	GND	EXTIO	BIASJ	GND	CLK VDD	IO VDD2	GND	ALARM	SDO
11	DAC CLKN	GND	PLL AVDD	PLL AVDD	AVDD	AVDD	AVDD	AVDD	AVDD	AVDD	TEST MODE	GND	SLEEP	SDIO
10	GND	GND	GND	AVDD	DAC VDD	DAC VDD	DAC VDD	DAC VDD	DAC VDD	DAC VDD	AVDD	GND	RESET B	SDENB
9	OSTR P	OSTR N	GND	DAC VDD	DAC VDD	GND	GND	GND	GND	DAC VDD	DAC VDD	GND	TXENA	SCLK
8	SYNC P	SYNC N	GND	GND	GND	GND	GND	GND	GND	GND	GND	GND	PARITY CDP	PARITY CDN
7	DAB 15P	DAB 15N	GND	VFUSE	DIG VDD	GND	GND	GND	GND	DIG VDD	VFUSE	GND	DCD 0P	DCD 0N
6	DAB 14P	DAB 14N	GND	IO VDD	DIG VDD	GND	GND	GND	GND	DIG VDD	IO VDD	GND	DCD 1P	DCD 1N
5	DAB 13P	DAB 13N	GND	IO VDD	DIG VDD	DIG VDD	IO VDD	IO VDD	DIG VDD	DIG VDD	IO VDD	GND	DCD 2P	DCD 2N
4	DAB 12P	DAB 12N	DAB 8P	DAB 6P	DAB 4P	DAB 2P	DAB 0P	DCD 15P	DCD 14P	DCD 12P	DCD 10P	DCD 8P	DCD 3P	DCD 3N
3	DAB 11P	DAB 11N	DAB 8N	DAB 6N	DAB 4N	DAB 2N	DAB 0N	DCD 15N	DCD 14N	DCD 12N	DCD 10N	DCD 8N	DCD 4P	DCD 4N
2	DAB 10P	DAB 10N	DAB 7P	DAB 5P	DAB 3P	DAB 1P	DATA CLKP	ISTR/ PARITY ABP	DCD 13P	DCD 11P	DCD 9P	DCD 7P	DCD 5P	DCD 5N
1	DAB 9P	DAB 9N	DAB 7N	DAB 5N	DAB 3N	DAB 1N	DATA CLKN	ISTR/ PARITY ABN	DCD 13N	DCD 11N	DCD 9N	DCD 7N	DCD 6P	DCD 6N

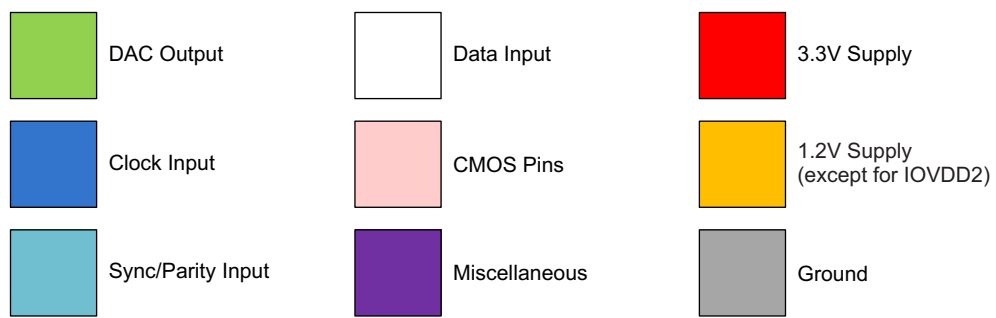

P0134-01

Pin Functions

PIN		I/O	DESCRIPTION
NAME	NO.		
AVDD	D10, E11, F11, G11, H11, J11, K11, L10	I	Analog supply voltage. (3.3 V)
ALARM	N12	O	CMOS output for ALARM condition. The ALARM output functionality is defined through the <i>config7</i> register. Default polarity is active-high, but can be changed to active-low via the <i>config0 alarm_out_pol</i> control bit.
BIASJ	H12	O	Full-scale output current bias. For 30-mA full-scale output current, connect 1.28 kΩ to ground. Change the full-scale output current through <i>coarse_dac(3:0)</i> in <i>config3, bit<15:12></i> .
CLKVDD	C12, K12	I	Internal clock buffer supply voltage. (1.35 V). It is recommended to isolate this supply from DIGVDD and DACVDD.
DAB[15..0]P	A7, A6, A5, A4, A3, A2, A1, C4, C2, D4, D2, E4, E2, F4, F2, G4	I	LVDS positive input data bits 0 through 15 for the AB-channel path. Internal 100-Ω termination resistor. Data format relative to DATACLKP/N clock is double data rate (DDR). DAB15P is the most-significant data bit (MSB). DAB0P is the least-significant data bit (LSB). The order of the bus can be reversed via the <i>config2 revbus</i> bit.
DAB[15..0]N	B7, B6, B5, B4, B3, B2, B1, C3, C1, D3, D1, E3, E1, F3, F1, G3	I	LVDS negative input data bits 0 through 15 for the AB-channel path. (See the preceding DAB[15:0]P description.)
DCD[15..0]P	H4, J4, J2, K4, K2, L4, L2, M4, M2, N1, N2, N3, N4, N5, N6, N7	I	LVDS positive input data bits 0 through 15 for the CD-channel path. Internal 100-Ω termination resistor. Data format relative to DATACLKP/N clock is double data rate (DDR). DCD15P is the most-significant data bit (MSB). DCD0P is the least-significant data bit (LSB). The order of the bus can be reversed via the <i>config2 revbus</i> bit.
DCD[15..0]N	H3, J3, J1, K3, K1, L3, L1, M3, M1, P1, P2, P3, P4, P5, P6, P7	I	LVDS negative input data bits 0 through 15 for the CD-channel path. (See the preceding DCD[15:0]P description.)
DACCLKP	A12	I	Positive external LVPECL clock input for DAC core with a self-bias
DACCLKN	A11	I	Complementary external LVPECL clock input for DAC core. (See the DACCLKP description.)
DACVDD	D9, E9, E10, F10, G10, H10, J10, K10, K9, L9	I	DAC core supply voltage. (1.35 V). It is recommended to isolate this supply from CLKVDD and DIGVDD.
DATACLKP	G2	I	LVDS positive input data clock. Internal 100-Ω termination resistor. Input data DAB[15:0]P/N and DCD[15:0]P/N are latched on both edges of DATACLKP/N (double data rate).
DATACLKN	G1	I	LVDS negative input data clock. (See the DATACLKP description.)
DIGVDD	E5, E6, E7, F5, J5, K5, K6, K7	I	Digital supply voltage. (1.3 V). It is recommended to isolate this supply from CLKVDD and DACVDD.
EXTIO	G12	I/O	Used as an external reference input when the internal reference is disabled through <i>config27 extref_ena</i> = 1. Used as an internal reference output when <i>config27 extref_ena</i> = 0 (default). Requires a 0.1-μF decoupling capacitor to AGND when used as a reference output.
ISTRP/ PARITYABP	H2	I	LVDS input strobe positive input. Internal 100-Ω termination resistor The main functions of this input are to sync the FIFO pointer, to provide a sync source to the digital blocks, and/or to act as a parity input for the AB-data bus. These functions are captured with the rising edge of DATACLKP/N. This signal should be edge-aligned with DAB[15:0]P/N and DCD[15:0]P/N. The PARITY, SYNC, and ISTR inputs are rotated to allow complete reversal of the data interface when setting the <i>rev_interface</i> bit in register <i>config1</i> .
ISTRN/ PARITYABN	H1	I	LVDS input strobe negative input. (See the ISTRP/PARITYABP description.)

Pin Functions (continued)

PIN		I/O	DESCRIPTION
NAME	NO.		
GND	A10, A13, A14, B10, B11, B12, B13, C5, C6, C7, C8, C9, C10, C13, D8, D13, D14, E8, E12, E13, F6, F7, F8, F9, F12, F13, G6, G7, G8, G9, G13, G14, H6, H7, H8, H9, H13, H14, J6, J7, J8, J9, J12, J13, K8, K13, L8, L13, L14, M5, M6, M7, M8, M9, M10, M11, M12, M13, N13, P13, P14	I	These pins are ground for all supplies.
IOUTAP	B14	O	A-channel DAC current output. Connect directly to ground if unused.
IOUTAN	C14	O	A-channel DAC complementary current output. Connect directly to ground if unused.
IOUTBP	F14	O	B-channel DAC current output. Connect directly to ground if unused.
IOUTBN	E14	O	B-channel DAC complementary current output. Connect directly to ground if unused.
IOUTCP	J14	O	C-channel DAC current output. Connect directly to ground if unused.
IOUTCN	K14	O	C-channel DAC complementary current output. Connect directly to ground if unused.
IOUTDP	N14	O	D-channel DAC current output. Connect directly to ground if unused.
IOUTDN	M14	O	D-channel DAC complementary current output. Connect directly to ground if unused.
IOVDD	D5, D6, G5, H5, L5, L6	I	Supply voltage for all LVDS I/O. (3.3 V)
IOVDD2	L12	I	Supply voltage for all CMOS I/O. (1.8 V to 3.3 V) This supply can range from 1.8 V to 3.3 V to change the input and output levels of the CMOS I/O.
LPF	D12	I/O	PLL loop filter connection. If not using the clock-multiplying PLL, the LPF pin can be left unconnected.
OSTRP	A9	I	Optional LVPECL output strobe positive input. This positive-negative pair is captured with the rising edge of DACCLKP/N. It is used to sync the divided-down clocks and FIFO output pointer in dual-sync-sources mode. If unused it can be left unconnected.
OSTRN	B9	I	Optional LVPECL output strobe negative input. (See the OSTRP description.)
PARITYCDP	N8	I	Optional LVDS positive input parity bit for the CD-data bus. The PARITYCDP/N LVDS pair has an internal 100-Ω termination resistor. If unused, it can be left unconnected. The PARITY, SYNC, and ISTR inputs are rotated to allow complete reversal of the data interface when setting the <i>rev_interface</i> bit in register <i>config1</i> .
PARITYCDN	P8	I	Optional LVDS negative input parity bit for the CD-data bus.
PLLAVDD	C11, D11	I	PLL analog supply voltage (3.3 V)
SCLK	P9	I	Serial interface clock. Internal pulldown
SDENB	P10	I	Active-low serial data enable, always an input to the DAC34SH84. Internal pullup
SDIO	P11	I/O	Serial interface data. Bidirectional in 3-pin mode (default) and unidirectional 4-pin mode. Internal pulldown
SDO	P12	O	Unidirectional serial interface data in 4-pin mode. The SDO pin is in the high-impedance state in 3-pin interface mode (default).
SLEEP	N11	I	Active-high asynchronous hardware power-down input. Internal pulldown

Pin Functions (continued)

PIN		I/O	DESCRIPTION
NAME	NO.		
SYNCP	A8	I	LVDS SYNC positive input. Internal 100-Ω termination resistor. If unused it can be left unconnected. The PARITY, SYNC, and ISTR inputs are rotated to allow complete reversal of the data interface when setting the <i>rev_interface</i> bit in register <i>config1</i> .
SYNCPN	B8	I	LVDS SYNC negative input
RESETB	N10	I	Active-low input for chip RESET. Internal pullup
TXENA	N9	I	Transmit enable active-high input. Internal pulldown To enable analog output data transmission, set <i>sif_txenable</i> in register <i>config3</i> to 1 or pull the CMOS TXENA pin to high. To disable analog output, set <i>sif_txenable</i> to 0 and pull the CMOS TXENA pin to low. The DAC output is forced to midscale.
TESTMODE	L11	I	This pin is used for factory testing. Internal pulldown. Leave unconnected for normal operation
VFUSE	D7, L7	I	Digital supply voltage. This supply pin is also used for factory fuse programming. Connect to DACVDD or DIGVDD for normal operation

6 Specifications

6.1 Absolute Maximum Ratings

 over operating free-air temperature range (unless otherwise noted)⁽¹⁾

		MIN	MAX	UNIT
Supply voltage range ⁽²⁾	DACVDD, DIGVDD, CLKVDD	-0.5	1.5	V
	VFUSE	-0.5	1.5	V
	IOVDD, IOVDD2	-0.5	4	V
	AVDD, PLLAVDD	-0.5	4	V
Pin voltage range ⁽²⁾	DAB[15..0]P/N, DCD[15..0]P/N, DATACLKP/N, ISTRP/N, PARITYCDP/N, SYNCP/N	-0.5	IOVDD + 0.5	V
	DACCLKP/N, OSTRP/N	-0.5	CLKVDD + 0.5	V
	ALARM, SDO, SDIO, SCLK, SDENB, SLEEP, RESETB, TESTMODE, TXENA	-0.5	IOVDD2 + 0.5	V
	IOUTAP/N, IOUTBP/N, IOUTCP/N, IOUTDP/N	-1.0	AVDD + 0.5	V
	EXTIO, BIASJ	-0.5	AVDD + 0.5	V
	LPF	-0.5	PLLA VDD + 0.5	V
Peak input current (any input)			20	mA
Peak total input current (all inputs)			-30	mA
Absolute maximum junction temperature, T _J			150	°C
Storage temperature range, T _{stg}		-65	150	°C

(1) Stresses beyond those listed under *Absolute Maximum Ratings* may cause permanent damage to the device. These are stress ratings only, and functional operation of these or any other conditions beyond those indicated under *Recommended Operating Conditions* is not implied. Exposure to absolute-maximum-rated conditions for extended periods may affect device reliability.

(2) Measured with respect to GND

6.2 ESD Ratings

		VALUE	UNIT
V _(ESD) Electrostatic discharge	Human-body model (HBM), per ANSI/ESDA/JEDEC JS-001 ⁽¹⁾	±2000	V
	Charged-device model (CDM), per JEDEC specification JESD22-C101 ⁽²⁾	±500	

(1) JEDEC document JEP155 states that 500-V HBM allows safe manufacturing with a standard ESD control process.

(2) JEDEC document JEP157 states that 250-V CDM allows safe manufacturing with a standard ESD control process.

6.3 Recommended Operating Conditions

		MIN	NOM	MAX	UNIT
T _J	Recommended operating junction temperature			105	°C
	Maximum rated operating junction temperature ⁽¹⁾	125			
T _A	Recommended free-air temperature	–40	25	85	°C

(1) Prolonged use at this junction temperature may increase the device failure-in-time (FIT) rate.

6.4 Thermal Information

THERMAL METRIC ⁽¹⁾		DAC34SH84			UNIT
		ZAY (NFBGA)			
		196 PINS			
R _{θJA}	Junction-to-ambient thermal resistance	37.6			°C/W
R _{θJC(top)}	Junction-to-case (top) thermal resistance	6.8			°C/W
R _{θJB}	Junction-to-board thermal resistance	16.8			°C/W
Ψ _{JT}	Junction-to-top characterization parameter	0.2			°C/W
Ψ _{JB}	Junction-to-board characterization parameter	16.4			°C/W
R _{θJC(bot)}	Junction-to-case (bottom) thermal resistance	NA			°C/W

(1) For more information about traditional and new thermal metrics, see the *Semiconductor and IC Package Thermal Metrics* application report, [SPRA953](#).

6.5 Electrical Characteristics – DC Specifications

over recommended operating free-air temperature range, nominal supplies, I_{OUTFS} = 20 mA (unless otherwise noted)⁽¹⁾

PARAMETER		TEST CONDITIONS	MIN	TYP	MAX	UNIT
Resolution			16			Bits
DC ACCURACY						
DNL	Differential nonlinearity	1 LSB = I _{OUTFS} / 2 ¹⁶	±2			LSB
INL	Integral nonlinearity		±4			LSB
ANALOG OUTPUT						
Coarse gain linearity			±0.04			LSB
Offset error		Mid-code offset	±0.001			%FSR
Gain error		With external reference	±2			%FSR
		With internal reference	±2			%FSR
Gain mismatch		With internal reference	±2			%FSR
Full-scale output current			10	20	30	mA
Output compliance range			–0.5		0.6	V
Output resistance			300			kΩ
Output capacitance			5			pF
REFERENCE OUTPUT						
V _{REF}	Reference output voltage		1.2			V
	Reference output current ⁽²⁾		100			nA
REFERENCE INPUT						
V _{EXTIO}	Input voltage range	External reference mode	0.6	1.2	1.25	V
	Input resistance		1			MΩ
	Small-signal bandwidth		472			kHz
	Input capacitance		100			pF

(1) Measured differentially across I_{OUTP}/N with 25 Ω each to GND.

(2) Use an external buffer amplifier with high-impedance input to drive any external load.

Electrical Characteristics – DC Specifications (continued)

 over recommended operating free-air temperature range, nominal supplies, $I_{OUT_{FS}} = 20 \text{ mA}$ (unless otherwise noted)

PARAMETER		TEST CONDITIONS	MIN	TYP	MAX	UNIT
TEMPERATURE COEFFICIENTS						
Offset drift				±1		ppm / °C
Gain drift		With external reference		±15		ppm / °C
		With internal reference		±30		ppm / °C
Reference voltage drift				±8		ppm / °C
POWER SUPPLY⁽³⁾						
AVDD, IOVDD, PLLAVDD			3.14	3.3	3.46	V
DIGVDD			1.25	1.3	1.35	V
CLKVDD, DACVDD			1.3	1.35	1.4	V
IOVDD2			1.71	3.3	3.45	V
PSRR	Power-supply rejection ratio	DC tested		±0.25		%FSR / V
POWER CONSUMPTION						
$I_{(AVDD)}$	Analog supply current ⁽⁴⁾	Mode 1 $f_{DAC} = 1.5 \text{ GSPS}$, 2x interpolation, mixer on, QMC on, invsinc on, PLL enabled, 20-mA FS output, IF = 200 MHz		135	165	mA
$I_{(DIGVDD)}$	Digital supply current			885	950	mA
$I_{(DACVDD)}$	DAC supply current			45	60	mA
$I_{(CLKVDD)}$	Clock supply current			127	145	mA
P	Power dissipation			1828	2056	mW
$I_{(AVDD)}$	Analog supply current ⁽⁴⁾	Mode 2 $f_{DAC} = 1.47456 \text{ GSPS}$, 2x interpolation, mixer on, QMC on, invsinc on, PLL disabled, 20-mA FS output, IF = 7.3 MHz		115		mA
$I_{(DIGVDD)}$	Digital supply current			770		mA
$I_{(DACVDD)}$	DAC supply current			40		mA
$I_{(CLKVDD)}$	Clock supply current			95		mA
P	Power dissipation			1562		mW
$I_{(AVDD)}$	Analog supply current ⁽⁴⁾	Mode 3 $f_{DAC} = 737.28 \text{ MSPS}$, 2x interpolation, mixer on, QMC on, invsinc off, PLL disabled, 20-mA FS output, IF = 7.3 MHz		115		mA
$I_{(DIGVDD)}$	Digital supply current			470		mA
$I_{(DACVDD)}$	DAC supply current			21		mA
$I_{(CLKVDD)}$	Clock supply current			55		mA
P	Power dissipation			1093		mW
$I_{(AVDD)}$	Analog supply current ⁽⁴⁾	Mode 4 $f_{DAC} = 1.47456 \text{ GSPS}$, 2x interpolation, mixer on, QMC on, invsinc on, PLL enabled, IF = 7.3 MHz, channels A/B/C/D output sleep		40		mA
$I_{(DIGVDD)}$	Digital supply current			710		mA
$I_{(DACVDD)}$	DAC supply current			50		mA
$I_{(CLKVDD)}$	Clock supply current			90		mA
P	Power dissipation			1160		mW
$I_{(AVDD)}$	Analog supply current ⁽⁴⁾	Mode 5 Power-down mode: no clock, DAC on sleep mode (clock receiver sleep), channels A/B/C/D output sleep, static data pattern		28		mA
$I_{(DIGVDD)}$	Digital supply current			17		mA
$I_{(DACVDD)}$	DAC supply current			0		mA
$I_{(CLKVDD)}$	Clock supply current			20		mA
P	Power dissipation			142		mW
$I_{(AVDD)}$	Analog supply current ⁽⁴⁾	Mode 6 $f_{DAC} = 1 \text{ GSPS}$, 2x interpolation, mixer off, QMC off, invsinc off, PLL enabled, 20-mA FS output, IF = 7.3 MHz		130		mA
$I_{(DIGVDD)}$	Digital supply current			570		mA
$I_{(DACVDD)}$	DAC supply current			25		mA
$I_{(CLKVDD)}$	Clock supply current			98		mA
P	Power dissipation			1336		mA

(3) To ensure power supply accuracy and to account for power supply filter network loss at operating conditions, the use of the ATEST function in register *config27* to check the internal power supply nodes is recommended.

(4) Includes AVDD, PLLAVDD, and IOVDD

Electrical Characteristics – DC Specifications (continued)

over recommended operating free-air temperature range, nominal supplies, $I_{OUT_{FS}} = 20 \text{ mA}$ (unless otherwise noted)

PARAMETER		TEST CONDITIONS	MIN	TYP	MAX	UNIT
$I_{(AVDD)}$	Analog supply current ⁽⁴⁾	Mode 7 $f_{DAC} = 1 \text{ GSPS}$, 2x interpolation, mixer off, QMC off, invsinc off, PLL disabled, 20-mA FS output, IF = 7.3 MHz		115		mA
$I_{(DIGVDD)}$	Digital supply current			335		mA
$I_{(DACVDD)}$	DAC supply current			23		mA
$I_{(CLKVDD)}$	Clock supply current			70		mA
P	Power dissipation			940		mW
$I_{(AVDD)}$	Analog supply current ⁽⁴⁾	Mode 8 $f_{DAC} = 1.47456 \text{ GSPS}$, 2x interpolation, mixer on, QMC on, invsinc on, PLL disabled, IF = 7.3 MHz, channels A/B/C/D output sleep		45		mA
$I_{(DIGVDD)}$	Digital supply current			655		mA
$I_{(DACVDD)}$	DAC supply current			30		mA
$I_{(CLKVDD)}$	Clock supply current			95		mA
P	Power dissipation			1169		mW

6.6 Electrical Characteristics – Digital Specifications

over operating free-air temperature range (unless otherwise noted)

PARAMETER		TEST CONDITIONS	MIN	TYP	MAX	UNIT
LVDS INPUTS: DAB[15:0]P/N, DCD[15:0]P/N, DATACLKP/N, ISTRP/N, SYNCNP/N, PARITYCDP/N⁽¹⁾						
$V_{A,B+}$	Logic-high differential input voltage threshold		200			mV
$V_{A,B-}$	Logic-low differential input voltage threshold				-200	mV
V_{COM}	Input common mode		1	1.2	1.6	V
Z_T	Internal termination		85	110	135	Ω
C_L	LVDS input capacitance			2		pF
f_{INTERL}	Interleaved LVDS data transfer rate				1500	MSPS
f_{DATA}	Input data rate				750	MSPS
CLOCK INPUT (DACCLKP/N)						
	Differential voltage ⁽²⁾	DACCLKP - DACCLKN	0.4	1		V
	Internally biased common-mode voltage			0.2		V
	Single-ended swing level		-0.4			V
OUTPUT STROBE (OSTRP/N)						
	Differential voltage	OSTRP-OSTRN	0.4	1.0		V
	Internally biased common-mode voltage			0.2		V
	Single-ended swing level		-0.4			V
CMOS INTERFACE: ALARM, SDO, SDIO, SCLK, SDENB, SLEEP, RESETB, TXENA						
V_{IH}	High-level input voltage		$0.7 \times$ IOVDD2			V
V_{IL}	Low-level input voltage				$0.3 \times$ IOVDD2	V
I_{IH}	High-level input current		-40		40	μA

(1) See [LVDS Inputs](#) section for terminology.

(2) Driving the clock input with a differential voltage lower than 1 V may result in degraded performance.

Electrical Characteristics – Digital Specifications (continued)

over operating free-air temperature range (unless otherwise noted)

PARAMETER		TEST CONDITIONS	MIN	TYP	MAX	UNIT
I_{IL}	Low-level input current		-40		40	μ A
C_I	CMOS input capacitance			2		pF
V_{OH}	ALARM, SDO, SDIO	$I_{load} = -100 \mu$ A	IOVDD2 – 0.2			V
		$I_{load} = -2$ mA	0.8 × IOVDD2			V
V_{OL}	ALARM, SDO, SDIO	$I_{load} = 100 \mu$ A			0.2	V
		$I_{load} = 2$ mA			0.5	V
PHASE-LOCKED LOOP						
PLL/VCO operating frequency	PLL_vco = 011110 (30)		2940		2957	MHz
	PLL_vco = 100010 (34)		2957		3000	
	PLL_vco = 100110 (38)		3000		3043	
	PLL_vco = 101010 (42)		3034		3086	
	PLL_vco = 101110 (46)		3069		3120	
	PLL_vco = 110010 (50)		3103		3163	
	PLL_vco = 110110 (54)		3128		3215	
	PLL_vco = 111010 (58)		3170		3257	
	PLL_vco = 111111 (63)		3215		3300	

6.7 Electrical Characteristics – AC Specifications

 over recommended operating free-air temperature range, nominal supplies, $I_{OUT_{FS}} = 20$ mA (unless otherwise noted)

PARAMETER		TEST CONDITIONS	MIN	TYP	MAX	UNIT
AC PERFORMANCE⁽¹⁾						
SFDR	Spurious-free dynamic range, (0 to $f_{DAC} / 2$) tone at 0 dBFS	$f_{DAC} = 1.5$ GSPS, $f_{OUT} = 20$ MHz		78		dBc
		$f_{DAC} = 1.5$ GSPS, $f_{OUT} = 50$ MHz		74		
		$f_{DAC} = 1.5$ GSPS, $f_{OUT} = 70$ MHz		71		
IMD3	Third-order two-tone intermodulation distortion, each tone at -12 dBFS	$f_{DAC} = 1.5$ GSPS, $f_{OUT} = 30 \pm 0.5$ MHz		87		dBc
		$f_{DAC} = 1.5$ GSPS, $f_{OUT} = 50 \pm 0.5$ MHz		85		
		$f_{DAC} = 1.5$ GSPS, $f_{OUT} = 100 \pm 0.5$ MHz		78		
NSD	Noise spectral density, ⁽²⁾ tone at 0 dBFS	$f_{DAC} = 1.5$ GSPS, $f_{OUT} = 10$ MHz		160		dBc / Hz
		$f_{DAC} = 1.5$ GSPS, $f_{OUT} = 80$ MHz		158		
ACLR ⁽²⁾	Adjacent-channel leakage ratio, single carrier	$f_{DAC} = 1.47456$ GSPS, $f_{OUT} = 30$ MHz		76		dBc
		$f_{DAC} = 1.47456$ GSPS, $f_{OUT} = 153$ MHz		75		
	Alternate-channel leakage ratio, single carrier	$f_{DAC} = 1.47456$ GSPS, $f_{OUT} = 30$ MHz		86		
		$f_{DAC} = 1.47456$ GSPS, $f_{OUT} = 153$ MHz		82		
Channel isolation		$f_{DAC} = 1.5$ GSPS, $f_{OUT} = 40$ MHz		101		dBc

 (1) 4:1 transformer output termination, 50- Ω doubly terminated load

(2) Single carrier, W-CDMA with 3.84-MHz BW, 5-MHz spacing, centered at IF, PAR = 12 dB. TESTMODEL 1, 10 ms

6.8 Timing Requirements – Digital Specifications

				MIN	NOM	MAX	UNIT	
CLOCK INPUT (DACCLKP/N)								
Duty cycle				40%		60%		
DACCLKP/N input frequency						1500	MHz	
OUTPUT STROBE (OSTRP/N)								
f_{OSTR}	Frequency	$f_{OSTR} = f_{DACCLK} / (n \times 8 \times \text{Interp})$ where n is any positive integer, f_{DACCLK} is DACCLK frequency in MHz			$f_{DACCLK} / (8 \times \text{interp})$		MHz	
Duty cycle				50%				
DIGITAL INPUT TIMING SPECIFICATIONS								
Timing LVDS inputs: DAB[15:0]P/N, DCD[15:0]P/N, ISTRP/N, SYNCN/P, PARITYCDP/N, double edge latching								
$t_{s(\text{DATA})}$	Setup time, DAB[15:0]P/N, DCD[15:0]P/N, ISTRP/N, SYNCN/P and PARITYP/N, valid to either edge of DATACLKP/N	ISTRP/N and SYNCN/P reset latched only on rising edge of DATACLKP/N	Config36 Setting		ps			
			datadly	clkdly				
			0	0				30
			0	1				-10
			0	2				-50
			0	3				-90
			0	4				-130
			0	5				-170
			0	6				-210
			0	7				-250
			1	0				50
			2	0				90
			3	0				130
			4	0				170
			$t_{h(\text{DATA})}$	Hold time, DAB[15:0]P/N, DCD[15:0]P/N, ISTRP/N, SYNCN/P and PARITYP/N, valid after either edge of DATACLKP/N				ISTRP/N and SYNCN/P reset latched only on rising edge of DATACLKP/N
datadly	clkdly							
0	0	200						
0	1	240						
0	2	280						
0	3	320						
0	4	360						
0	5	400						
0	6	440						
0	7	480						
1	0	190						
2	0	150						
3	0	110						
4	0	70						
$t_{(ISTR_SYNC)}$	ISTRP/N and SYNCN/P pulse width	f_{DATACLK} is DATACLK frequency in MHz			$1/2f_{\text{DATACLK}}$		ns	

Timing Requirements – Digital Specifications (continued)

		MIN	NOM	MAX	UNIT
TIMING OUTPUT STROBE INPUT: DACCLKP/N rising edge LATCHING⁽¹⁾					
$t_{s(OSTR)}$	Setup time, OSTRP/N valid to rising edge of DACCLKP/N		-80		ps
$t_{h(OSTR)}$	Hold time, OSTRP/N valid after rising edge of DACCLKP/N		220		ps
TIMING SYNC INPUT: DACCLKP/N rising edge LATCHING⁽²⁾					
$t_{s(SYNC_PLL)}$	Setup time, SYNC P/N valid to rising edge of DACCLKP/N		150		ps
$t_{h(SYNC_PLL)}$	Hold time, SYNC P/N valid after rising edge of DACCLKP/N		250		ps
TIMING SERIAL PORT					
$t_{s(SDENB)}$	Setup time, SDENB to rising edge of SCLK		20		ns
$t_{s(SDIO)}$	Setup time, SDIO valid to rising edge of SCLK		10		ns
$t_{h(SDIO)}$	Hold time, SDIO valid to rising edge of SCLK		5		ns
$t_{(SCLK)}$	Period of SCLK	Register <i>config6</i> read (temperature sensor read)	1		μs
		All other registers	100		ns
$t_{d(Data)}$	Data output delay after falling edge of SCLK		10		ns
t_{RESET}	Minimum RESETB pulse width		25		ns

- (1) OSTR is required in Dual Sync Sources mode. In order to minimize the skew it is recommended to use the same clock distribution device such as Texas Instruments CDCE62005 to provide the DACCLK and OSTR signals to all the DAC34H84 devices in the system. Swap the polarity of the DACCLK outputs with respect to the OSTR ones to establish proper phase relationship.
- (2) SYNC is required to synchronize the PLL circuit in multiple devices. The SYNC signal must meet the timing relationship with respect to the reference clock (DACCLKP/N) of the on-chip PLL circuit.

6.9 Switching Characteristics – AC Specifications

 over recommended operating free-air temperature range, nominal supplies, $I_{OUT_{FS}} = 20$ mA (unless otherwise noted)

PARAMETER		TEST CONDITIONS	MIN	TYP	MAX	UNIT
ANALOG OUTPUT⁽¹⁾						
$t_{s(DAC)}$	Output settling time to 0.1%	Transition: Code 0x0000 to 0xFFFF		10		ns
t_{pd}	Output propagation delay	DAC outputs are updated on the falling edge of DAC clock. Does not include Digital Latency (see below).		2		ns
$t_{r(IOUT)}$	Output rise time 10% to 90%			220		ps
$t_{f(IOUT)}$	Output fall time 90% to 10%			220		ps
Digital latency		No interpolation, FIFO on, Mixer off, QMC off, Inverse sinc off		128		DAC clock cycles
		2x Interpolation		216		
		4x Interpolation		376		
		8x Interpolation		726		
		16x Interpolation		1427		
		Fine mixer		24		
		QMC		16		
Power-up Time	DAC wake-up time	IOUT current settling to 1% of $I_{OUT_{FS}}$ from output sleep		2		μs
	DAC sleep time	IOUT current settling to less than 1% of $I_{OUT_{FS}}$ in output sleep		2		

- (1) Measured single ended into 50-Ω load.

6.10 Typical Characteristics

All plots are at 25°C, nominal supply voltage, $f_{DAC} = 1500$ MSPS, 2x interpolation, NCO enabled, mixer gain disabled, QMC enabled with gain set at 1446 for both I/Q channels, 0-dBFS digital input, 20-mA full-scale output current with 4:1 transformer (unless otherwise noted)

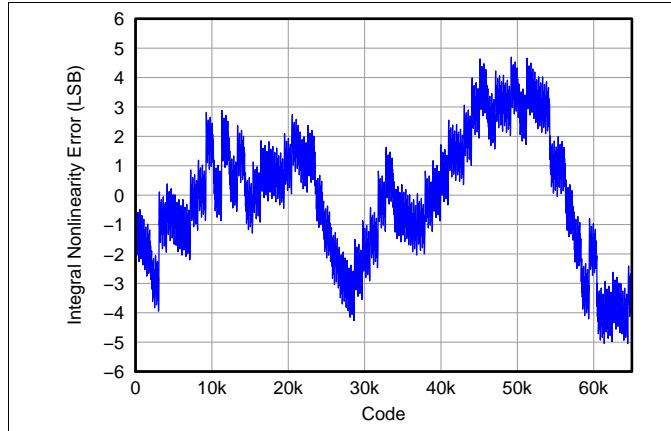

Figure 1. Integral Nonlinearity

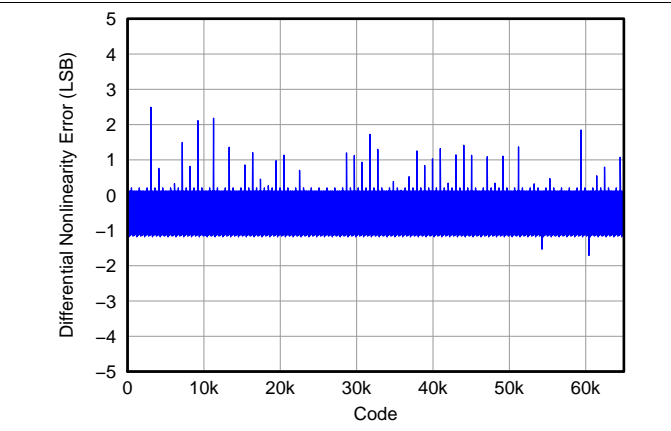

Figure 2. Differential Nonlinearity

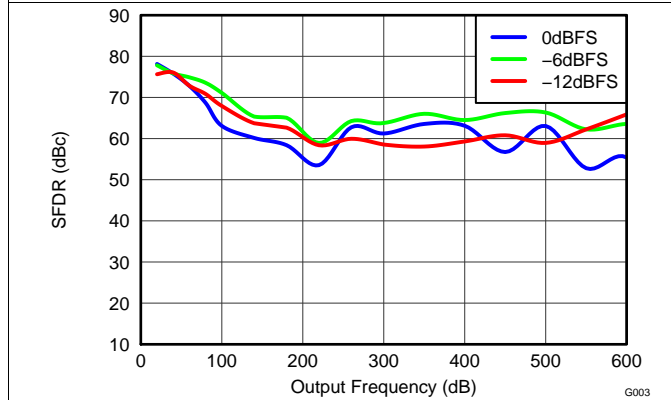

Figure 3. SFDR vs Output Frequency Over Input Scale

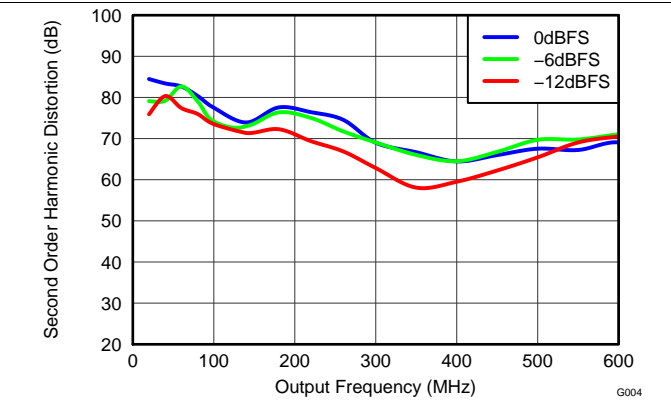

Figure 4. Second-Harmonic Distortion vs Output Frequency Over Input Scale

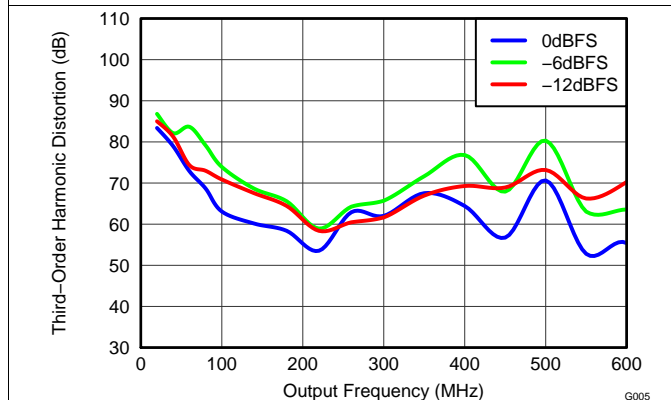

Figure 5. Third Harmonic Distortion vs Output Frequency Over Input Scale

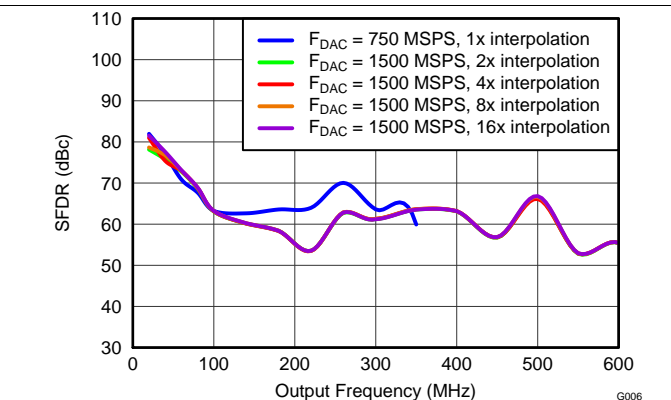
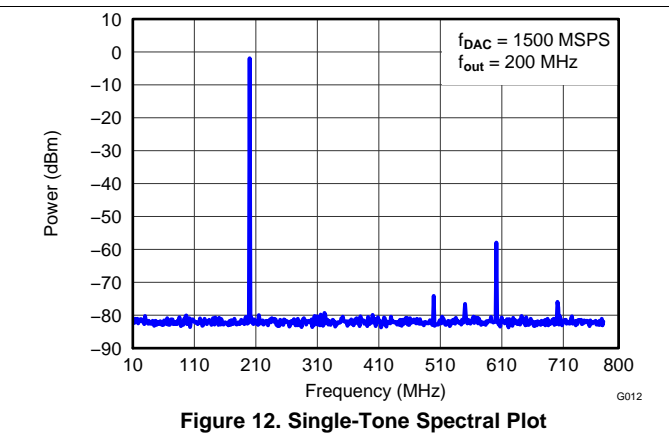
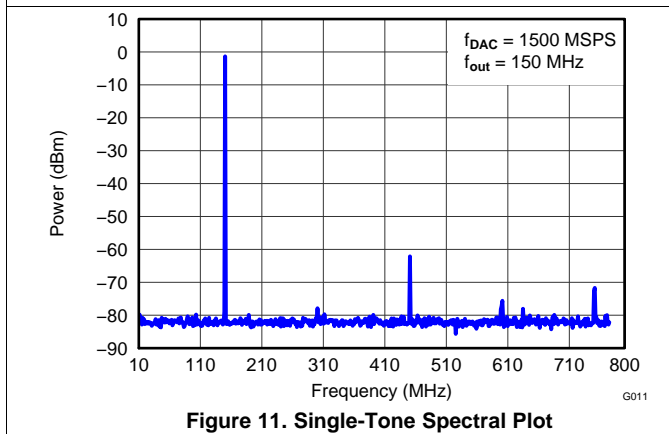
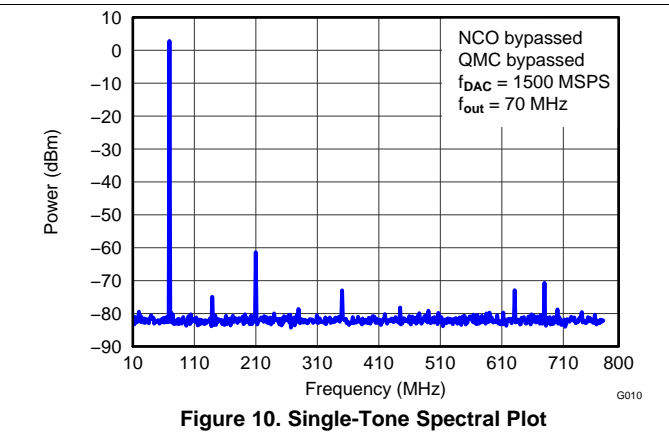
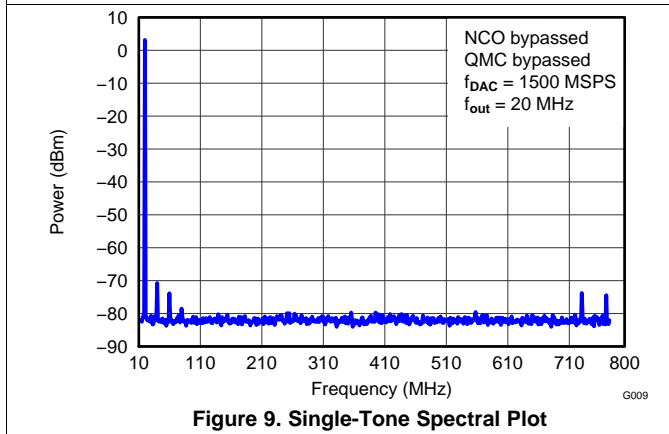
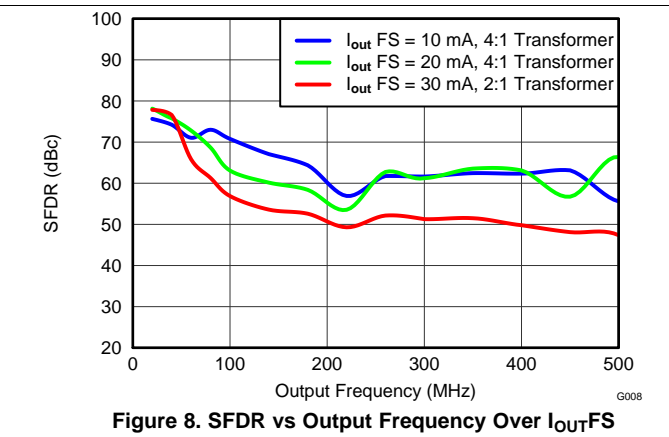
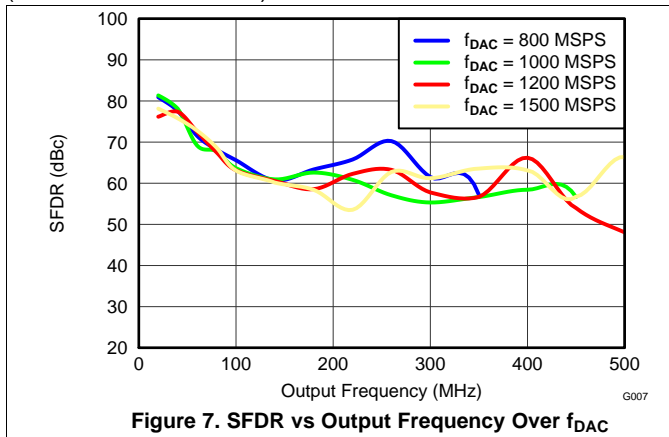

Figure 6. SFDR vs Output Frequency Over Interpolation

Typical Characteristics (continued)

All plots are at 25°C, nominal supply voltage, $f_{DAC} = 1500$ MSPS, 2x interpolation, NCO enabled, mixer gain disabled, QMC enabled with gain set at 1446 for both I/Q channels, 0-dBFS digital input, 20-mA full-scale output current with 4:1 transformer (unless otherwise noted)



Typical Characteristics (continued)

All plots are at 25°C, nominal supply voltage, $f_{DAC} = 1500$ MSPS, 2x interpolation, NCO enabled, mixer gain disabled, QMC enabled with gain set at 1446 for both I/Q channels, 0-dBFS digital input, 20-mA full-scale output current with 4:1 transformer (unless otherwise noted)

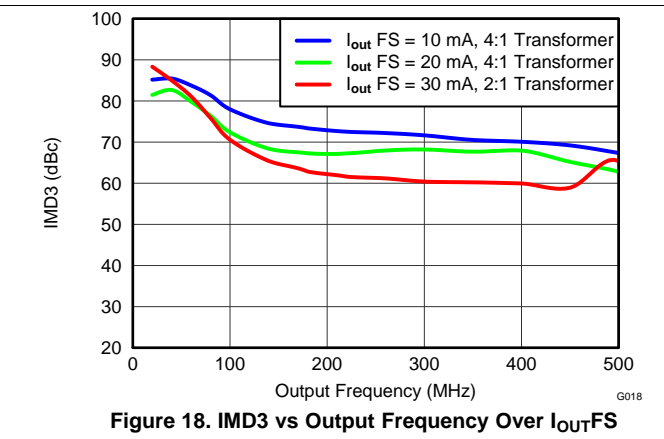
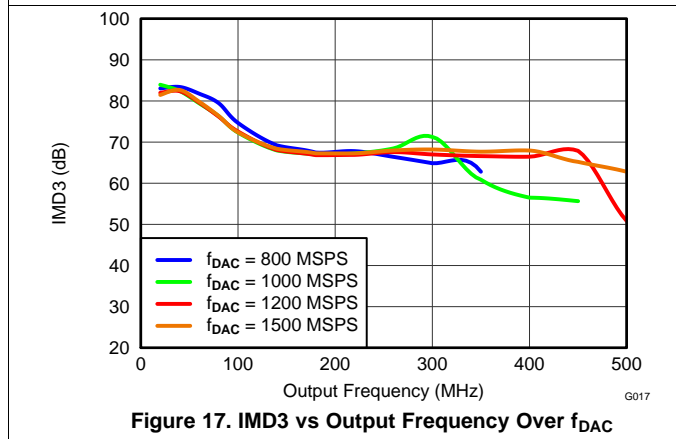
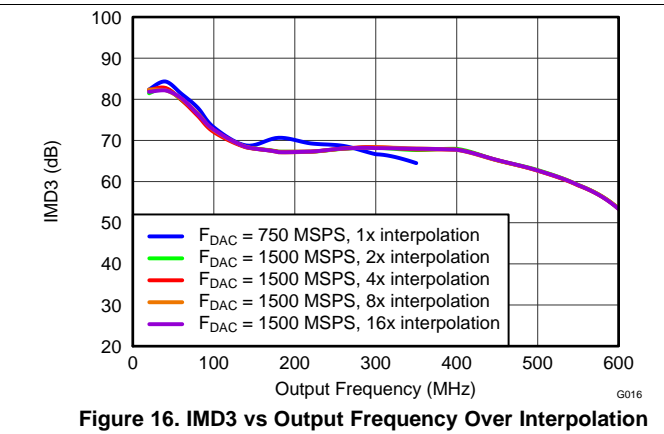
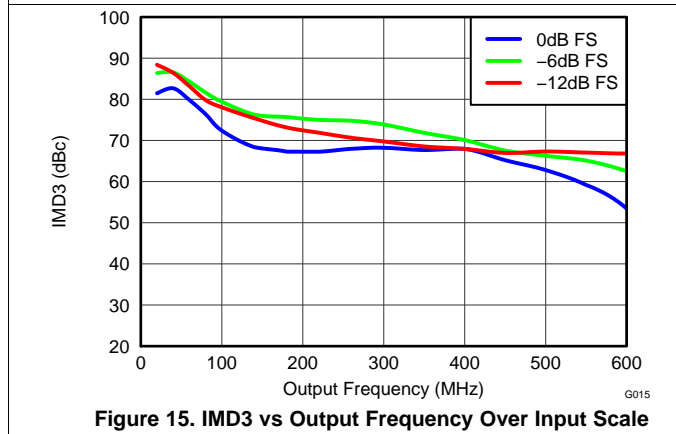
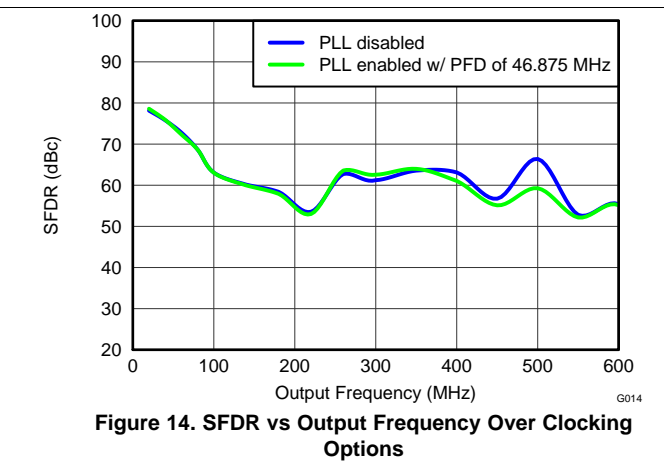
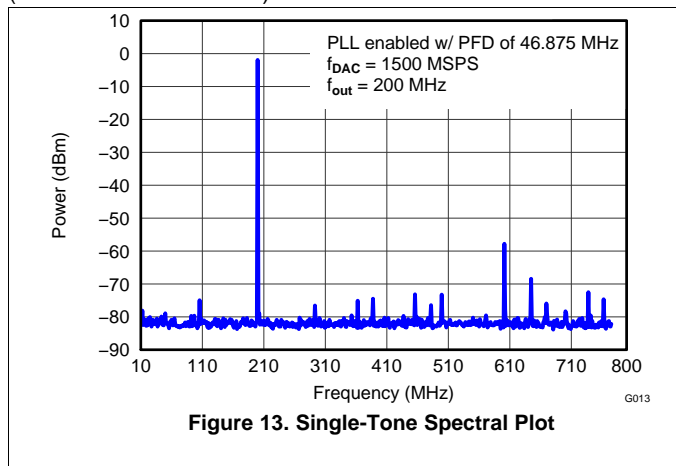

Typical Characteristics (continued)

All plots are at 25°C, nominal supply voltage, $f_{DAC} = 1500$ MSPS, 2x interpolation, NCO enabled, mixer gain disabled, QMC enabled with gain set at 1446 for both I/Q channels, 0-dBFS digital input, 20-mA full-scale output current with 4:1 transformer (unless otherwise noted)

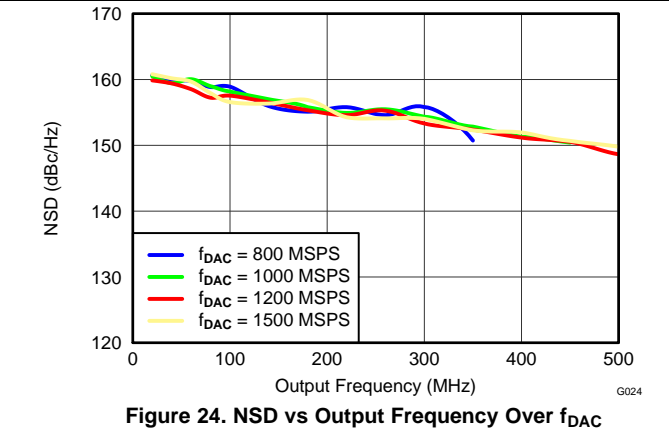
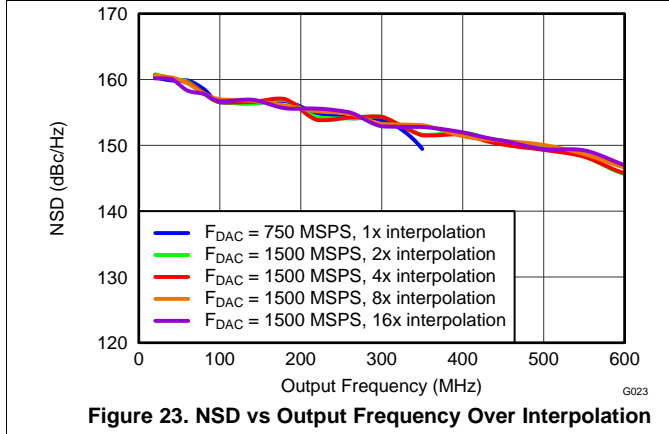
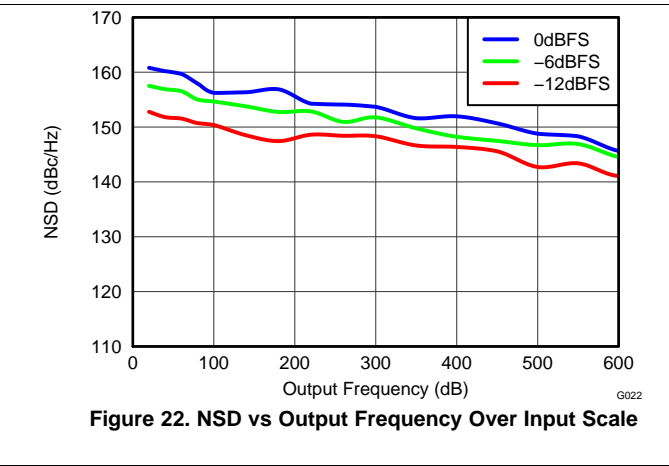
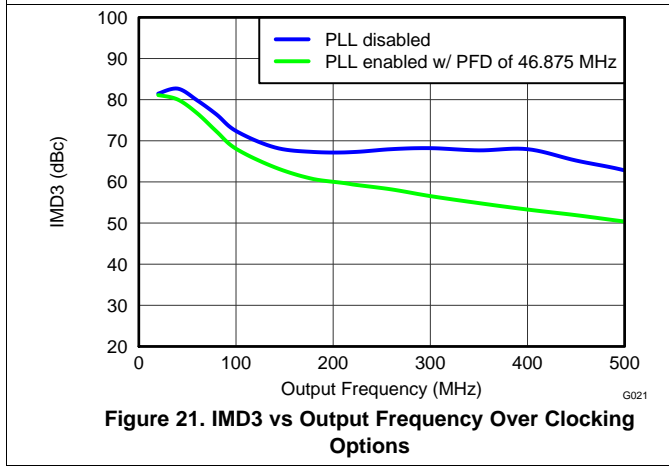
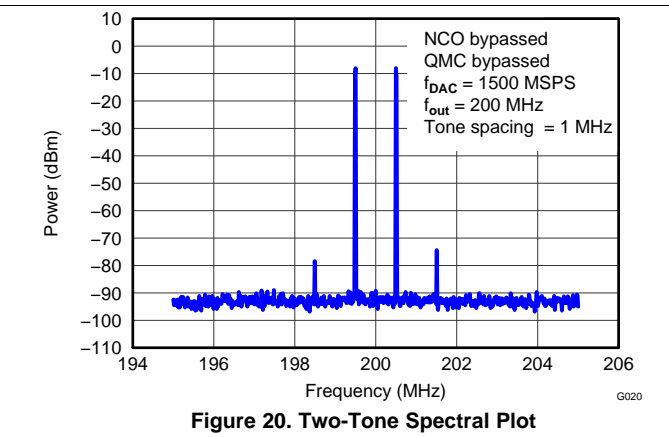
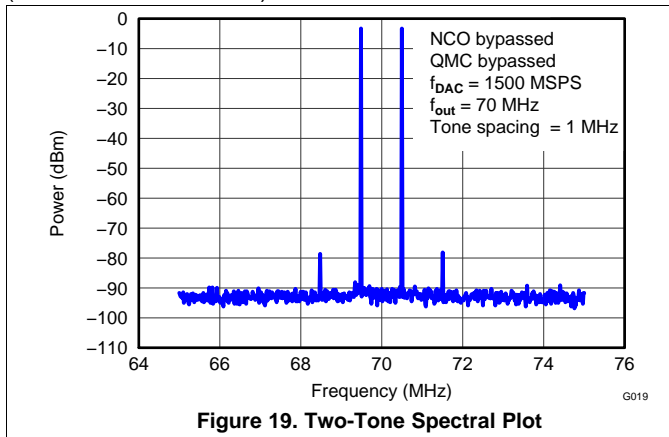

Typical Characteristics (continued)

All plots are at 25°C, nominal supply voltage, $f_{DAC} = 1500$ MSPS, 2x interpolation, NCO enabled, mixer gain disabled, QMC enabled with gain set at 1446 for both I/Q channels, 0-dBFS digital input, 20-mA full-scale output current with 4:1 transformer (unless otherwise noted)

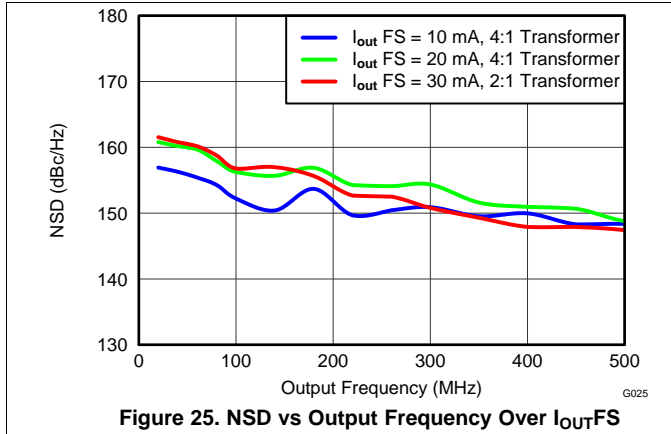

Figure 25. NSD vs Output Frequency Over I_{OUTFS}

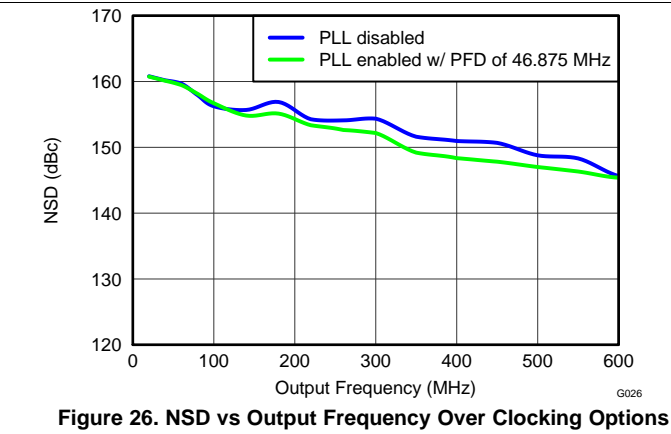

Figure 26. NSD vs Output Frequency Over Clocking Options

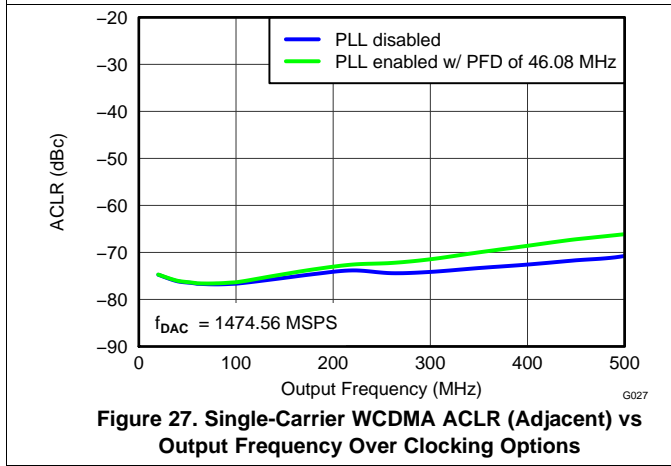

Figure 27. Single-Carrier WCDMA ACLR (Adjacent) vs Output Frequency Over Clocking Options

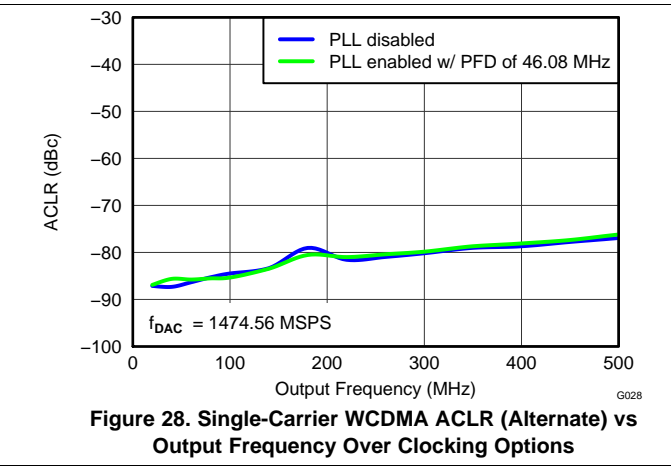

Figure 28. Single-Carrier WCDMA ACLR (Alternate) vs Output Frequency Over Clocking Options

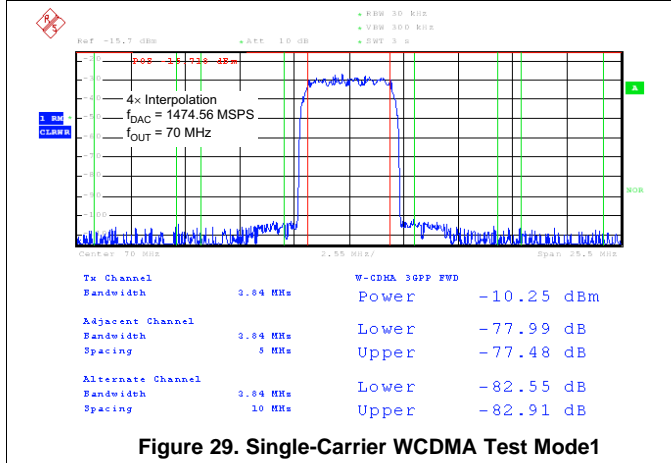

Figure 29. Single-Carrier WCDMA Test Mode1

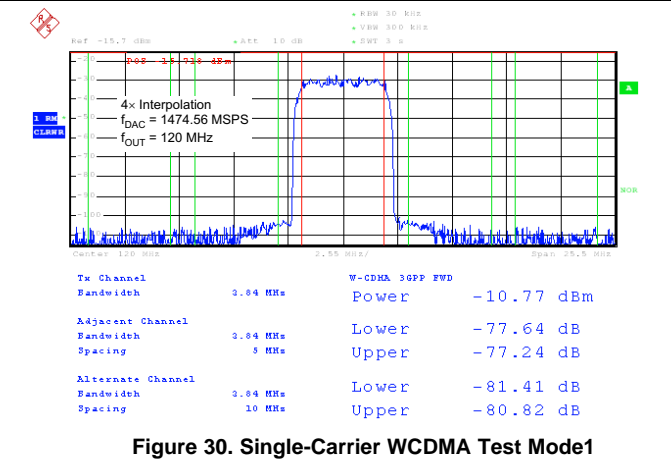
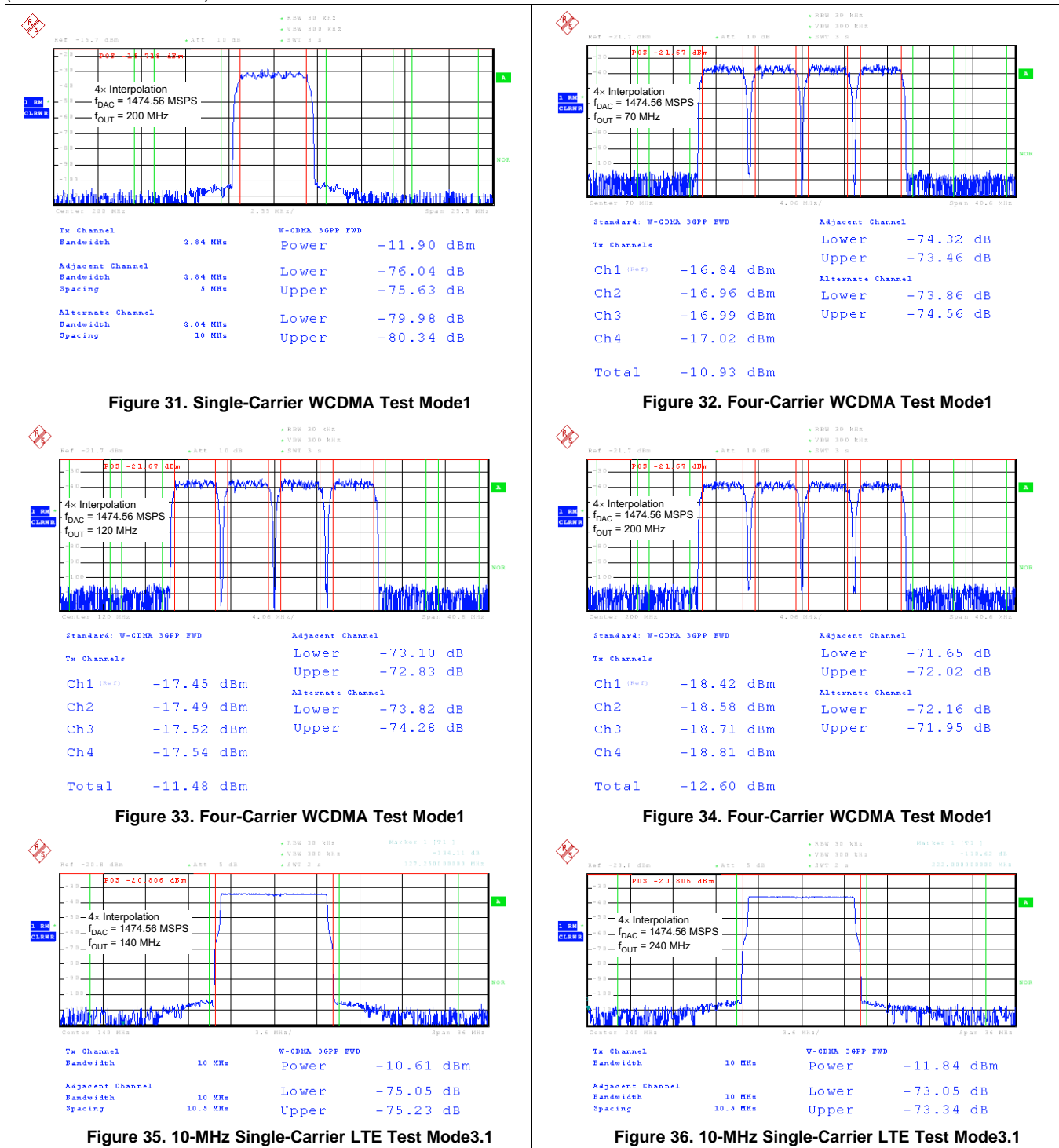

Figure 30. Single-Carrier WCDMA Test Mode1

Typical Characteristics (continued)

All plots are at 25°C, nominal supply voltage, $f_{DAC} = 1500$ MSPS, 2x interpolation, NCO enabled, mixer gain disabled, QMC enabled with gain set at 1446 for both I/Q channels, 0-dBFS digital input, 20-mA full-scale output current with 4:1 transformer (unless otherwise noted)



Typical Characteristics (continued)

All plots are at 25°C, nominal supply voltage, $f_{DAC} = 1500$ MSPS, 2x interpolation, NCO enabled, mixer gain disabled, QMC enabled with gain set at 1446 for both I/Q channels, 0-dBFS digital input, 20-mA full-scale output current with 4:1 transformer (unless otherwise noted)

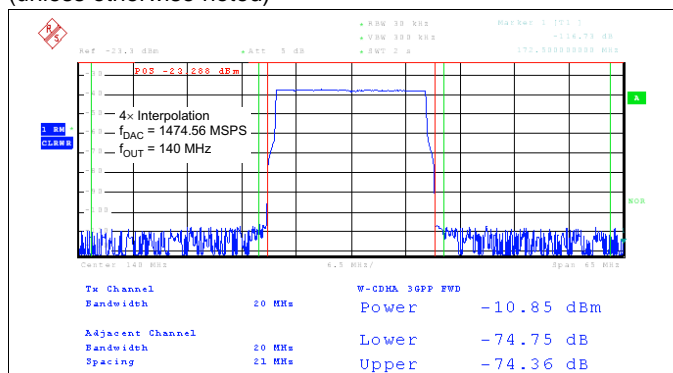

Figure 37. 20-MHz Single-Carrier LTE Test Mode3.1

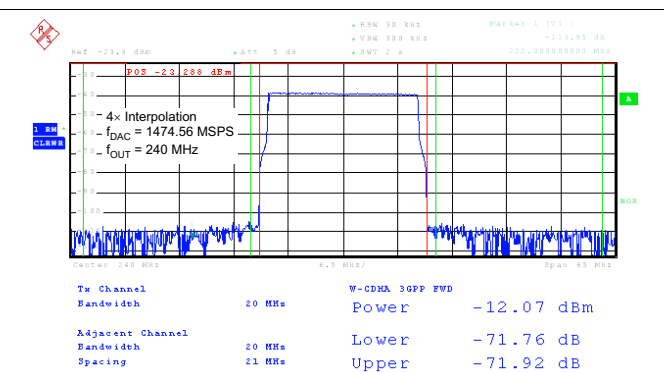

Figure 38. 20-MHz Single-Carrier LTE Test Mode3.1

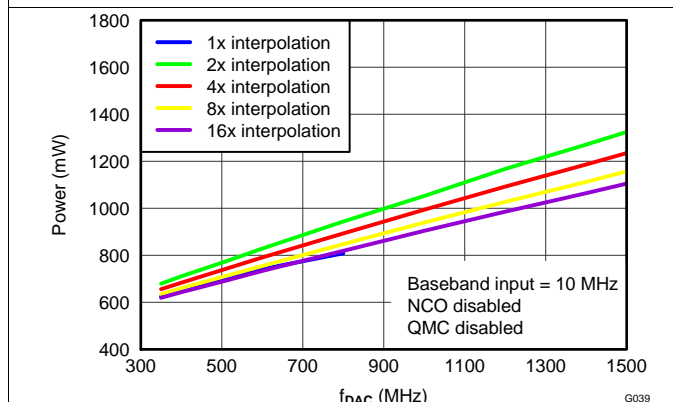

Figure 39. Power vs f_{DAC} Over Interpolation

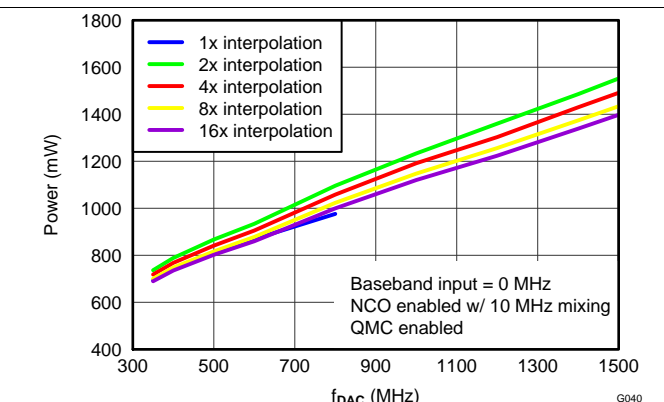

Figure 40. Power vs f_{DAC} Over Interpolation

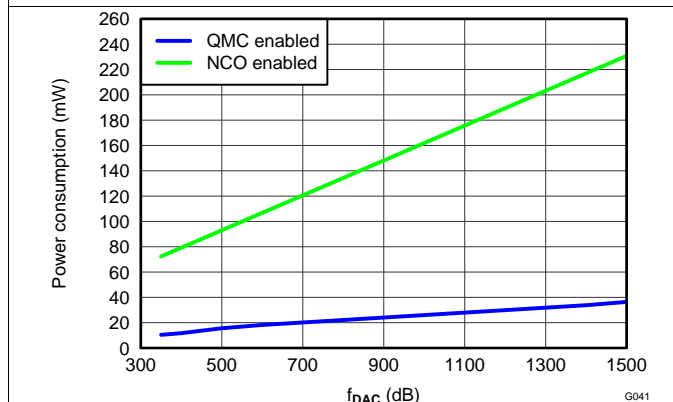

Figure 41. Power Consumption vs f_{DAC} Over Digital Processing Functions

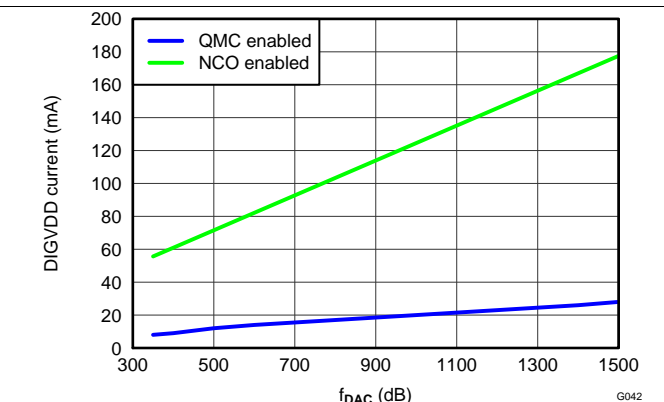

Figure 42. DIGVDD Current vs f_{DAC} Over Digital Processing Functions

DAC34SH84

SLAS808E – FEBRUARY 2012 – REVISED SEPTEMBER 2015

www.ti.com

Typical Characteristics (continued)

All plots are at 25°C, nominal supply voltage, $f_{DAC} = 1500$ MSPS, 2x interpolation, NCO enabled, mixer gain disabled, QMC enabled with gain set at 1446 for both I/Q channels, 0-dBFS digital input, 20-mA full-scale output current with 4:1 transformer (unless otherwise noted)

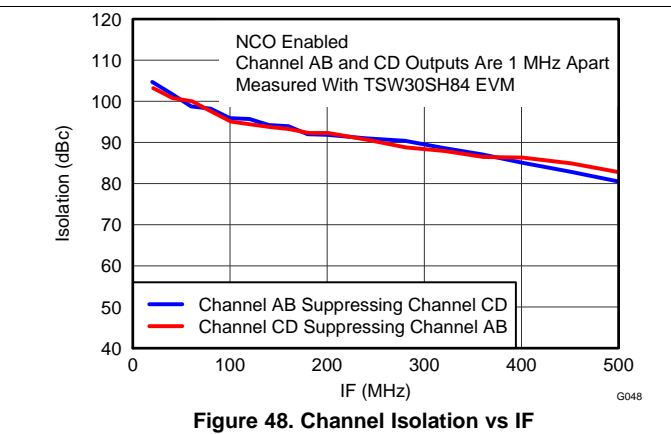
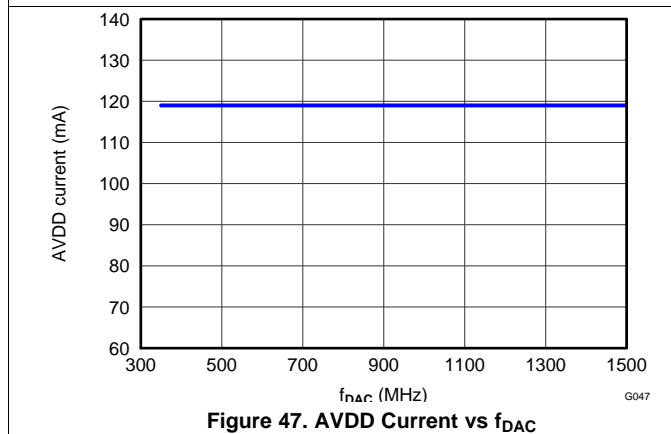
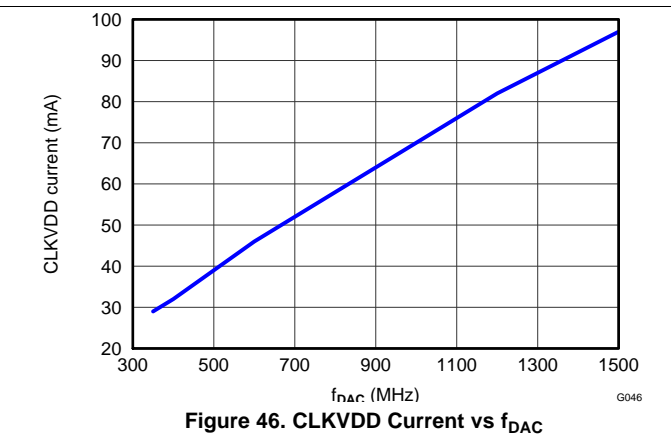
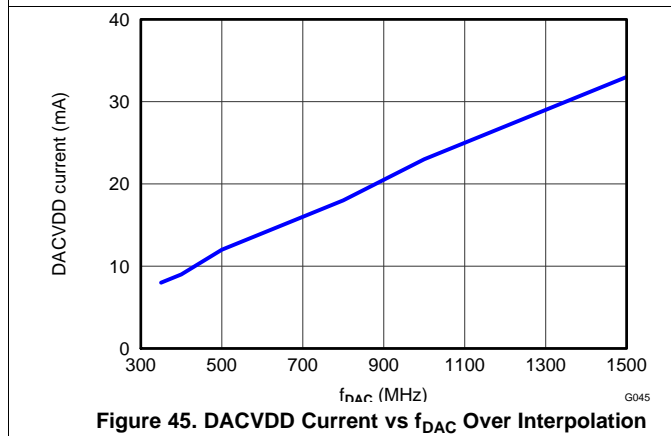
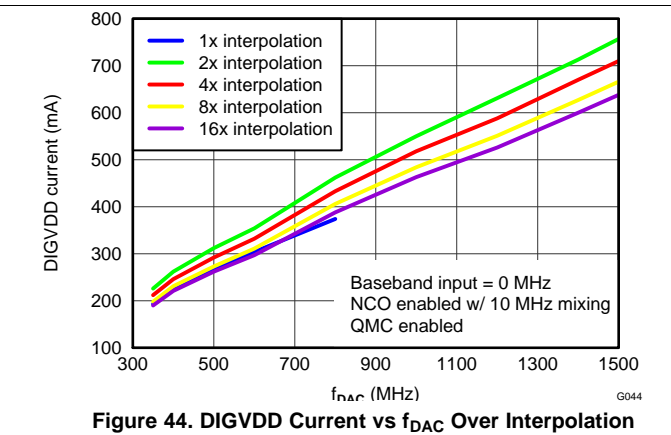
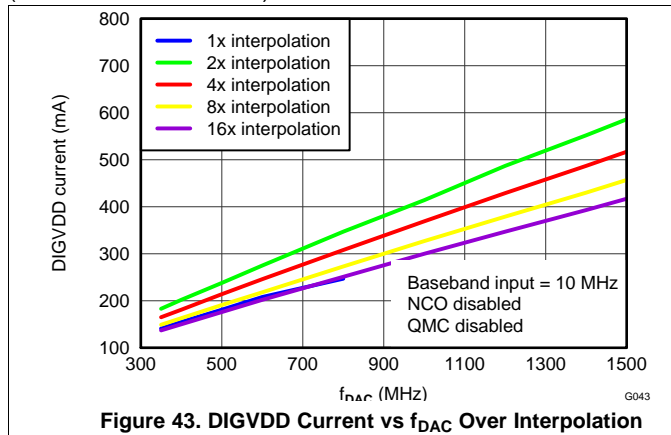

7 Detailed Description

7.1 Overview

The DAC34SH84 includes a quad-channel, 16-bit digital-to-analog converter (DAC) with up to 1.5 GSPS sample rate, a 32-bit LVDS data bus with on-chip termination, FIFO, data pattern checker, and parity test. The device includes 2x to 16x digital interpolation filters with over 90dB of stop-band attenuation, reconstruction filters, independent complex mixers, a low jitter clock multiplier, and digital Quadrature Modulator Correction (QMC).

Full synchronization of multiple devices is possible with the DAC3484. It is an ideal device for next generation communication systems.

DAC34SH84

SLAS808E – FEBRUARY 2012 – REVISED SEPTEMBER 2015

www.ti.com

7.2 Functional Block Diagram

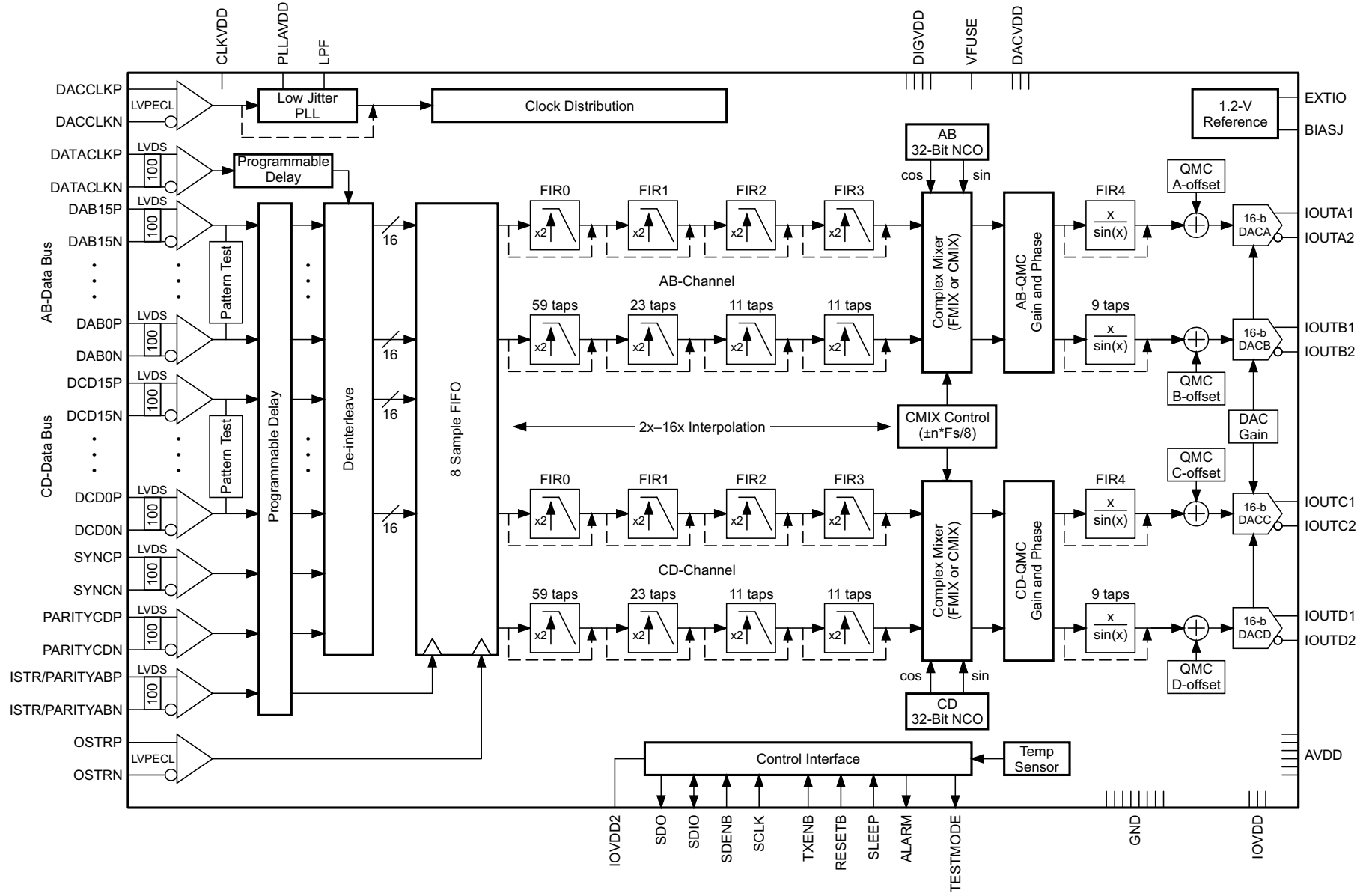

B0460-01

7.3 Feature Description

7.3.1 Serial Interface

The serial port of the DAC34SH84 is a flexible serial interface which communicates with industry-standard microprocessors and microcontrollers. The interface provides read/write access to all registers used to define the operating modes of the DAC34SH84. It is compatible with most synchronous transfer formats and can be configured as a three- or four-pin interface by *sif4_ena* in register *config2*. In both configurations, SCLK is the serial-interface input clock and SDENB is serial-interface enable. For the three-pin configuration, SDIO is a bidirectional pin for both data in and data out. For the four-pin configuration, SDIO is data-in only and SDO is data-out only. Data is input into the device with the rising edge of SCLK. Data is output from the device on the falling edge of SCLK.

Each read/write operation is framed by the serial-data enable bar (SDENB) signal asserted low. The first frame byte is the instruction cycle which identifies the following data transfer cycle as read or write as well as the 7-bit address to be accessed. Table 1 indicates the function of each bit in the instruction cycle and is followed by a detailed description of each bit. The data transfer cycle consists of two bytes.

Table 1. Instruction Byte of the Serial Interface

BIT	7 (MSB)	6	5	4	3	2	1	0 (LSB)
Description	R/W	A6	A5	A4	A3	A2	A1	A0

R/W Identifies the following data transfer cycle as a read or write operation. A high indicates a read operation from the DAC34SH84 and a low indicates a write operation to the DAC34SH84.

[A6 : A0] Identifies the address of the register to be accessed during the read or write operation.

Figure 49 shows the serial interface timing diagram for a DAC34SH84 write operation. SCLK is the serial interface clock input to DAC34SH84. Serial data enable SDENB is an active low input to DAC34SH84. SDIO is serial data in. Input data to DAC34SH84 is clocked on the rising edges of SCLK.

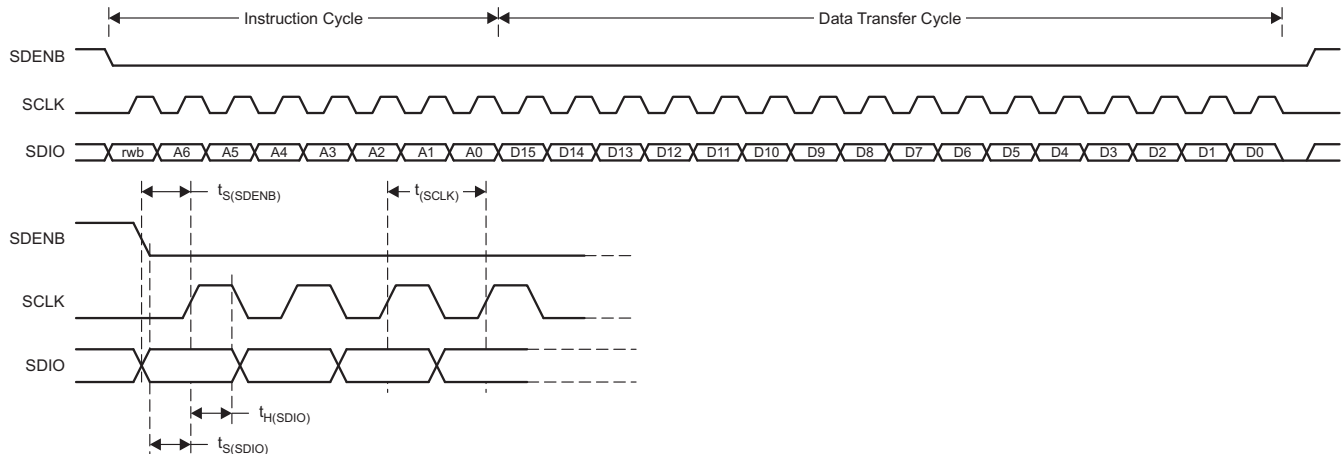

T0521-01

Figure 49. Serial-Interface Write Timing Diagram

Figure 50 shows the serial interface timing diagram for a DAC34SH84 read operation. SCLK is the serial interface clock input to the DAC34SH84. Serial-data enable SDENB is an active-low input to the DAC34SH84. SDIO is serial data-in during the instruction cycle. In the three-pin configuration, SDIO is data out from the DAC34SH84 during the data transfer cycle, whereas SDO is in a high-impedance state. In the four-pin configuration, SDO is data-out from the DAC34SH84 during the data transfer cycle. At the end of the data transfer, SDIO and SDO output low on the final falling edge of SCLK until the rising edge of SDENB, when SDO goes into the high-impedance state.

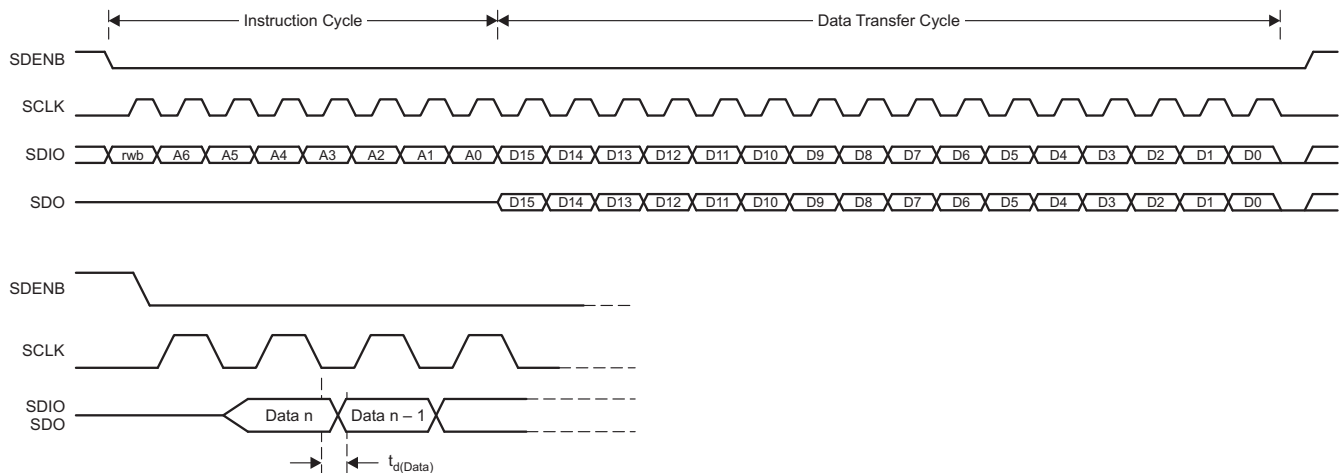

T0522-01

Figure 50. Serial-Interface Read Timing Diagram

7.3.2 Data Interface

The DAC34SH84 has a 32-bit LVDS bus that accepts quad, 16-bit data in word-wide format. The quad, 16-bit data can be input to the device using a dual-bus, 16-bit interface. The bus accepts LVDS transfer rates up to 1.5 GSPS, which corresponds to a maximum data rate of 750 MSPS per data channel. The default LVDS bus input assignment is shown in [Table 2](#).

Table 2. LVDS Bus Input Assignment

DATA PATHS	PINS
A and B	DAB[15..0]
C and D	DCD[15..0]

Data is sampled by the LVDS double-data-rate (DDR) clock DATACLK. Setup and hold requirements must be met for proper sampling. A and C data are captured on the rising edge of DATACLK. B and D data are captured on the falling edge of DATACLK.

For both input bus modes, a sync signal, either ISTR or SYNC, is required to sync the FIFO read and/or write pointers.

The sync signal, either ISTR or SYNC, can be either a pulse or a periodic signal where the sync period corresponds to multiples of eight samples. ISTR or SYNC is sampled by a rising edge in DATACLK. The pulse duration $t_{(ISTR_SYNC)}$ must be at least equal to one-half of the DATACLK period.

7.3.3 Data Format

The 16-bit data for channels A and B is interleaved in the form $A_0[15:0], B_0[15:0], A_1[15:0], B_1[15:0], A_2[15:0]...$ into the DAB[15:0]P/N LVDS inputs. Similarly, data for channels C and D is interleaved into the DCD[15:0]P/N LVDS inputs. Data into the DAC34SH84 is formatted according to the diagram shown in [Figure 51](#), where index 0 is the data LSB and index 15 is the data MSB.

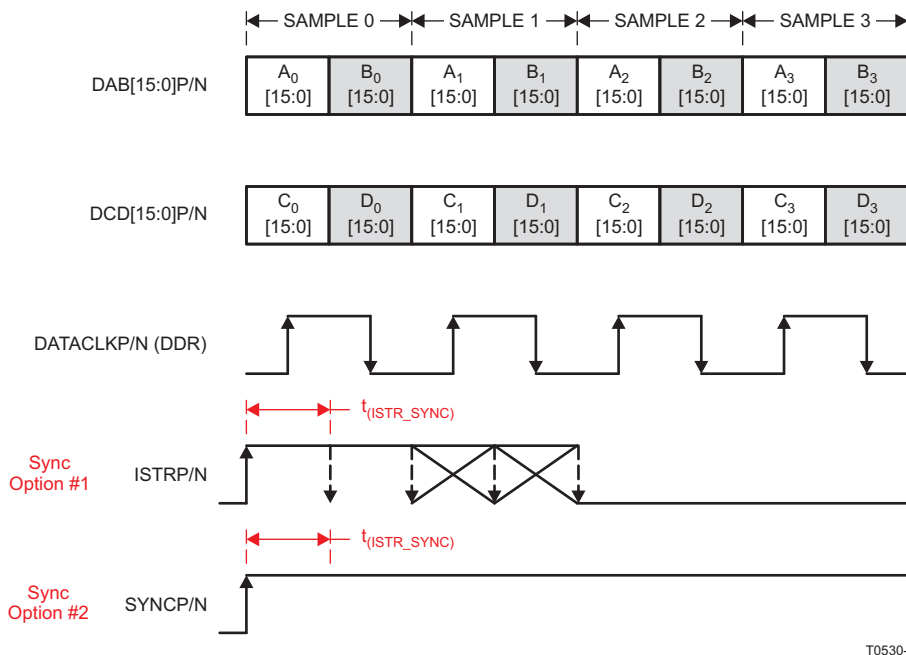

Figure 51. Data Transmission Format

The FIFO read and write pointer can also be synced by SIF SYNC as the third sync option if multi-device synchronization is not needed. In this sync mode, the *syncsel_fifoin(3:0)* and *syncsel_fifoout(3:0)* in register config32 need to be both set to 1000 for the SIF SYNC option.

7.3.4 Input FIFO

The DAC34SH84 includes a 4-channel, 16-bit-wide and 8-sample-deep input FIFO which acts as an elastic buffer. The purpose of the FIFO is to absorb any timing variations between the input data and the internal DAC data-rate clock, such as the ones resulting from clock-to-data variations from the data source.

Figure 52 shows a simplified block diagram of the FIFO.

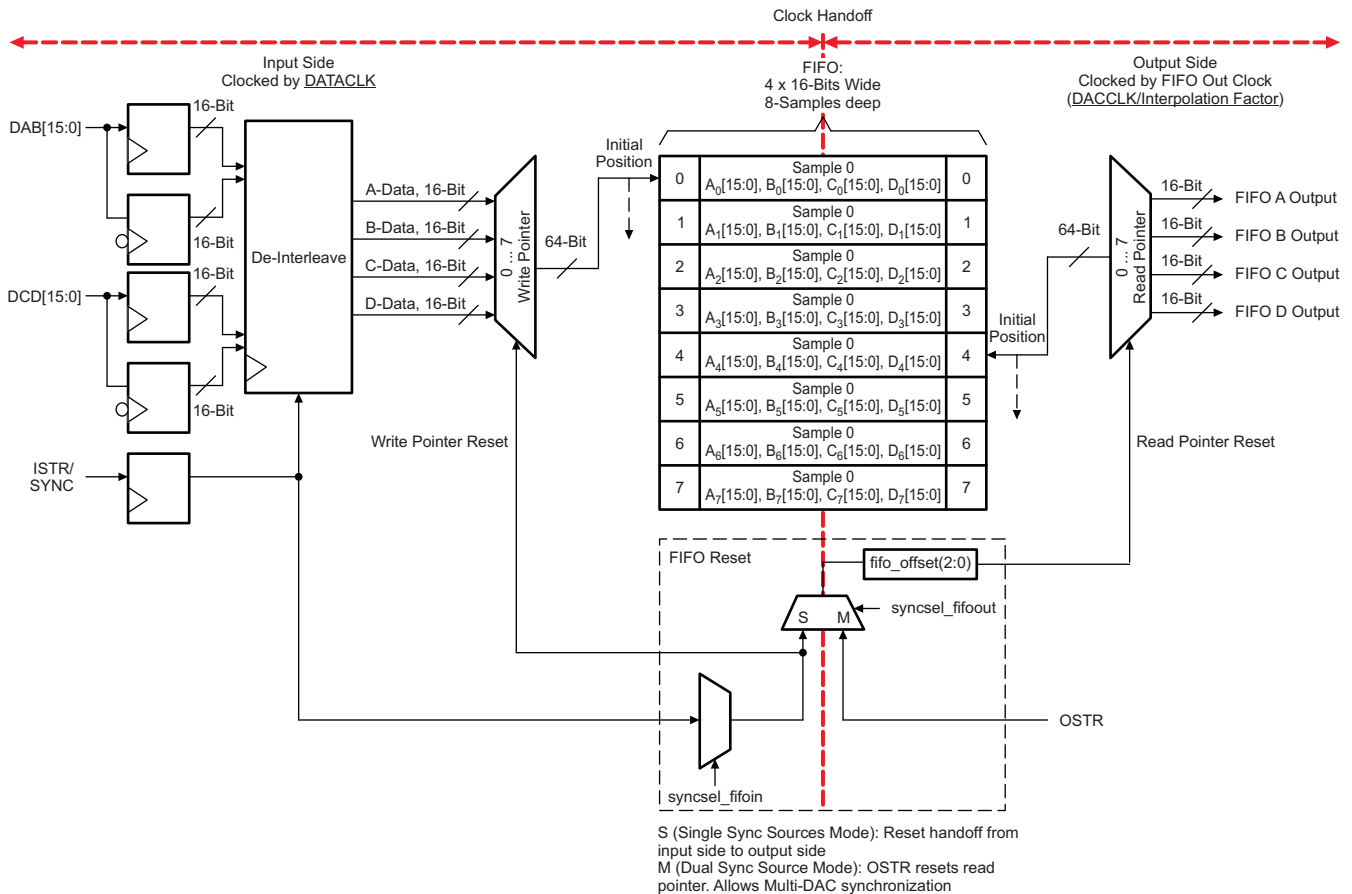

B0461-01

Figure 52. DAC34SH84 FIFO Block Diagram

Data is written to the device 32 bits at a time on the rising and falling edges of DATACLK. In order to form a complete 64-bit wide sample (16-bit A-data, 16-bit B-data, 16-bit C-data, and 16-bit D-data) one DATACLK period is required. Each 64-bit-wide sample is written into the FIFO at the address indicated by the write pointer. Similarly, data from the FIFO is read by the FIFO-out clock 64 bits at a time from the address indicated by the read pointer. The FIFO-out clock is generated internally from the DACCLK signal and its rate is equal to DACCLK / interpolation. Each time a FIFO write or FIFO read is done, the corresponding pointer moves to the next address.

The reset position for the FIFO read and write pointers is set by default to addresses 0 and 4 as shown in Figure 52. This offset gives optimal margin within the FIFO. The default read pointer location can be set to another value using *fifo_offset(2:0)* in register *config9* (address 4 by default). Under normal conditions, data is written to and read from the FIFO at the same rate and consequently, the write and read pointer gap remains constant. If the FIFO write and read rates are different, the corresponding pointers cycle at different speeds, which could result in pointer collision. Under this condition, the FIFO attempts to read and write data from the same address at the same time, which results in errors and thus must be avoided.

The write pointer sync source is selected by *syncsel_fifoin(3:0)* in register *config32*. In most applications either ISTR or SYNC are used to reset the write pointer. Unlike DATA, the sync signal is latched only on the rising edges of DATACLK. A rising edge on the sync signal source causes the pointer to return to its original position.

Similarly, the read pointer sync source is selected by *syncsel_fifoout(3:0)*. The write pointer sync source can be set to reset the read pointer as well. In this case, the FIFO-out clock recaptures the write pointer sync signal to reset the read pointer. This clock domain transfer (DATACLK to FIFO Out Clock) results in phase ambiguity of the sync signal. This limits the precise control of the output timing and makes full synchronization of multiple devices difficult.

To alleviate this, the device offers the alternative of resetting the FIFO read pointer independently of the write pointer by using the OSTR signal. The OSTR signal is sampled by DACCLK and must satisfy the timing requirements in the specifications table. In order to minimize the skew it is recommended to use the same clock distribution device such as Texas Instruments CDCE62005 to provide the DACCLK and OSTR signals to all the DAC34SH84 devices in the system. Swapping the polarity of the DACCLK outputs with respect to the OSTR ones establishes proper phase relationship.

The FIFO pointers reset procedure can be done periodically or only once during initialization as the pointers automatically return to the initial position when the FIFO has been filled. To reset the FIFO periodically, it is necessary to have the ISTR, SYNC, and OSTR signals to repeat at multiples of 8 FIFO samples. To disable FIFO reset, set *syncsel_fifo_in(3:0)* and *syncsel_fifo_out(3:0)* to 0000.

The frequency limitation for ISTR and SYNC signals are the following:

$$f_{\text{sync}} = f_{\text{DATACLK}} / (n \times 8), \text{ where } n = 1, 2, \dots$$

The frequency limitation for the OSTR signal is the following:

$$f_{\text{OSTR}} = f_{\text{DAC}} / (n \times \text{interpolation} \times 8) \text{ where } n = 1, 2, \dots$$

The frequencies above are at maximum when $n = 1$. This is when the ISTR, SYNC, or OSTR have a rising edge transition every 8 FIFO samples. The occurrence can be made less frequent by setting $n > 1$, for example, every $n \times 8$ FIFO samples.

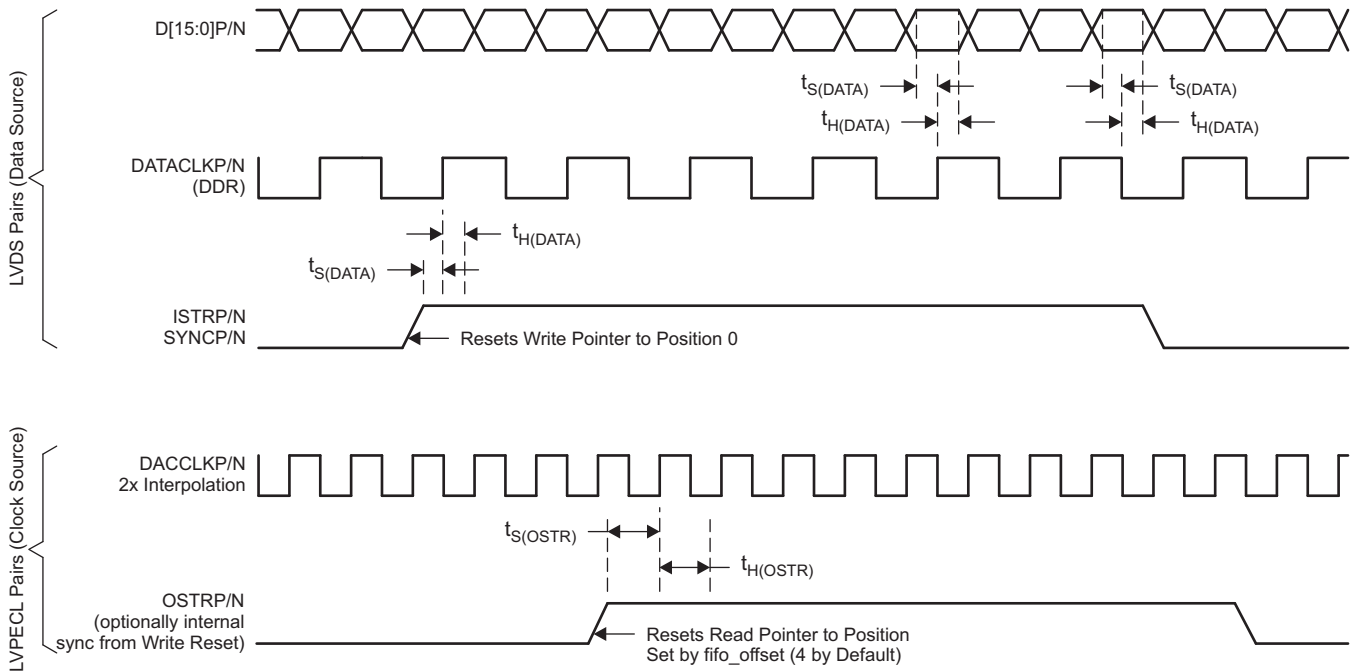

T0531-01

Figure 53. FIFO Write and Read Descriptions

7.3.5 FIFO Modes of Operation

The DAC34SH84 input FIFO can be completely bypassed through registers *config0* and *config32*. The register configuration for each mode is described in Table 3.

Register	Control Bits
config0	fifo_ena
config32	syncsel_fifoout(3:0)

Table 3. FIFO Operation Modes

FIFO MODE	<i>config0</i> AND <i>config32</i> FIFO Bits				
	fif_ena	syncsel_fifoout			
		BIT 3: sif_sync	BIT 2: OSTR	BIT 1: ISTR	BIT 0: SYNC
Dual Sync Sources	1	0	1	0	0
Single Sync Source	1	0	0	1 or 0 Depends on the sync source	1 or 0 Depends on the sync source
Bypass	0	X	X	X	X

7.3.5.1 Dual-Sync-Sources Mode

This is the recommended mode of operation for those applications that require precise control of the output timing. In Dual Sync Sources mode, the FIFO write and read pointers are reset independently. The FIFO write pointer is reset using the LVDS ISTR or SYNC signal, and the FIFO read pointer is reset using the LVPECL OSTR signal. This allows LVPECL OSTR signal to control the phase of the output for either a single chip or multiple chips. Multiple devices can be fully synchronized in this mode.

7.3.5.2 Single-Sync-Source Mode

In single-sync-source mode, the FIFO write and read pointers are reset from the same source, either LVDS ISTR or LVDS SYNC signal. This mode has a possibility of up to 2 DAC clocks offset between the multiple DAC outputs. Applications requiring exact output timing control need dual-sync-sources mode instead of single-sync-source mode. A single rising edge for FIFO and clock divider sync is recommended. Periodic sync signal is not recommended due to the non-deterministic latency of the sync signal through the clock domain transfer.

In this mode, there is a chance for FIFO pointers 2 away alarm (or possibly 1 away alarm) to occur at initial setup or syncing. This is the result of single-sync-source mode having 0 to 3 address location slip, which is caused by the asynchronous handoff of the sync signal occurring between the DATACLK zone and the DACCLK zone. The asynchronous relationship between the clock domains means there could be a slip (from nominal) in the READ and WRITE pointers at initial syncing. For example, with the default programming of FIFO offset of 4, the actual FIFO offset may be 3, 2, or in some instances, 1. Please note that in this mode, the nominal address location slip is 0 with the possibility getting less for each increase in slip amount. Also, the slip does not continue to occur as the device functions, but the READ/WRITE pointers may not be at optimal settings. If an alarm occurs:

1. Adjust the FIFO offset accordingly and resynchronize the FIFO, data formatter, etc., such that there are no alarms reported or at least only the 2-away alarm is reported.
2. The FIFO collision alarm is a warning of the system, because the read and write processes occur at the same pointer. However, the FIFO 1-away and 2-away alarms are informational for the system designer. The important thing for these two alarms is that the alarm should not get closer to collision during normal operation. If the 1-away alarm or collision alarm starts to occur, it is a warning to check for system errors. The system should have an interrupt or algorithm to fix the error and resynchronize the alarm appropriately.

7.3.5.3 Bypass Mode

In FIFO bypass mode, the FIFO block is not used. As a result, the input data is handed off from the DATACLK to the DACCLK domain without any compensation. In this mode, the relationship between DATACLK and DACCLK is critical and used as a synchronizing mechanism for the internal logic. Due to this constraint, this mode is **not recommended**. In bypass mode, the pointers have no effect on the data path or handoff. Because this mode does not require synchronization of the FIFO, the ISTR and SYNC signals are also bypassed. Therefore, the ISTR and SYNC LVDS pairs can be left unconnected.

7.3.6 Clocking Modes

The DAC34SH84 has a dual-clock setup in which a DAC clock signal is used to clock the DAC cores and internal digital logic, and a separate DATA clock is used to clock the input LVDS receivers and FIFO input. The DAC34SH84 DAC clock signal can be sourced directly or generated through an on-chip low-jitter phase-locked loop (PLL).

In those applications requiring extremely low noise it is recommended to bypass the PLL and source the DAC clock directly from a high-quality external clock to the DACCLK input. In most applications, system clocking can be simplified by using the on-chip PLL to generate the DAC core clock while still satisfying performance requirements. In this case, the DACCLK pins are used as the reference frequency input to the PLL.

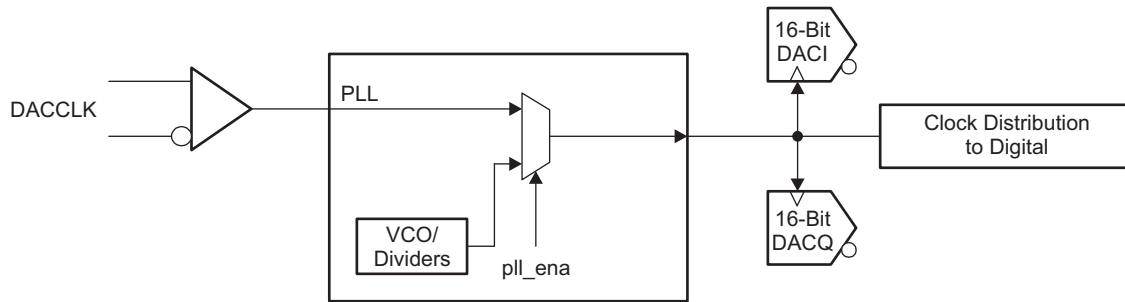

B0452-01

Figure 54. Top-Level Clock Diagram

7.3.6.1 PLL Bypass Mode

In PLL bypass mode, a very high-quality clock is sourced to the DACCLK inputs. This clock is used to directly source the DAC34SH84 DAC sample-rate clock. This mode gives the device best performance and is recommended for extremely demanding applications.

The bypass mode is selected by setting the following:

1. *pll_ena* bit in register *config24* to 0 to bypass the PLL circuitry.
2. *pll_sleep* bit in register *config26* to 1 to put the PLL and VCO into sleep mode.

7.3.6.2 PLL Mode

In this mode, the clock at the DACCLKP/N input functions as a reference clock source to the on-chip PLL. The on-chip PLL then multiplies this reference clock to supply a higher-frequency DAC sample-rate clock. Figure 55 shows the block diagram of the PLL circuit.

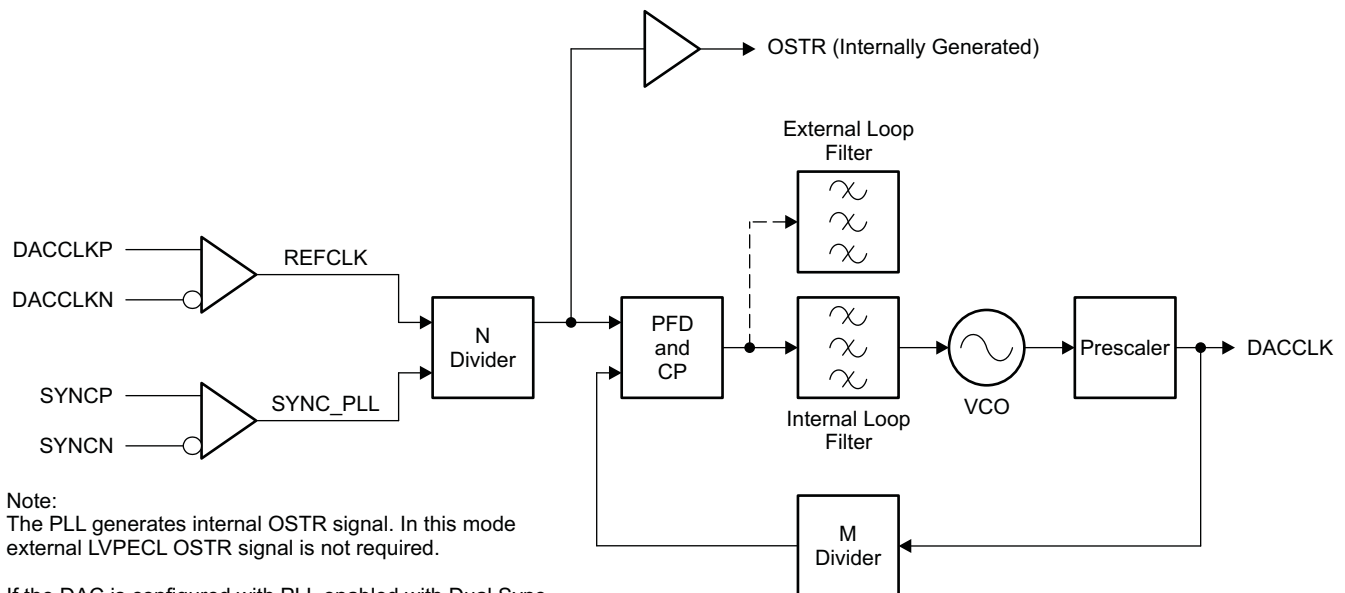

Note:
The PLL generates internal OSTR signal. In this mode external LVPECL OSTR signal is not required.

If the DAC is configured with PLL enabled with Dual Sync Sources mode, then the PFD frequency has to be the pre-defined OSTR frequency.

B0453-01

Figure 55. PLL Block Diagram

The DAC34SH84 PLL mode is selected by setting the following:

1. *pll_ena* bit in register *config24* to 1 to route to the PLL clock path.
2. *pll_sleep* bit in register *config26* to 0 to enable the PLL and VCO.

The output frequency of the VCO is designed to be in the range from 2.7 GHz to 3.3 GHz. The prescaler value, *pll_p(2:0)* in register *config24*, should be chosen such that the product of the prescaler value and DAC sample rate clock is within the VCO range. To maintain optimal PLL loop, the coarse-tuning bits, *pll_vco(5:0)* in register *config26*, can adjust the center frequency of the VCO toward the product of the prescaler value and DAC sample-rate clock. [Figure 56](#) shows a typical relationship between the coarse-tuning bits and VCO center frequency. See the Electrical Characteristics Table for recommended *pll_vco(5:0)* setting and the corresponding VCO frequency range. Following the recommended settings ensures optimal PLL lock range over operating temperature and voltage specifications.

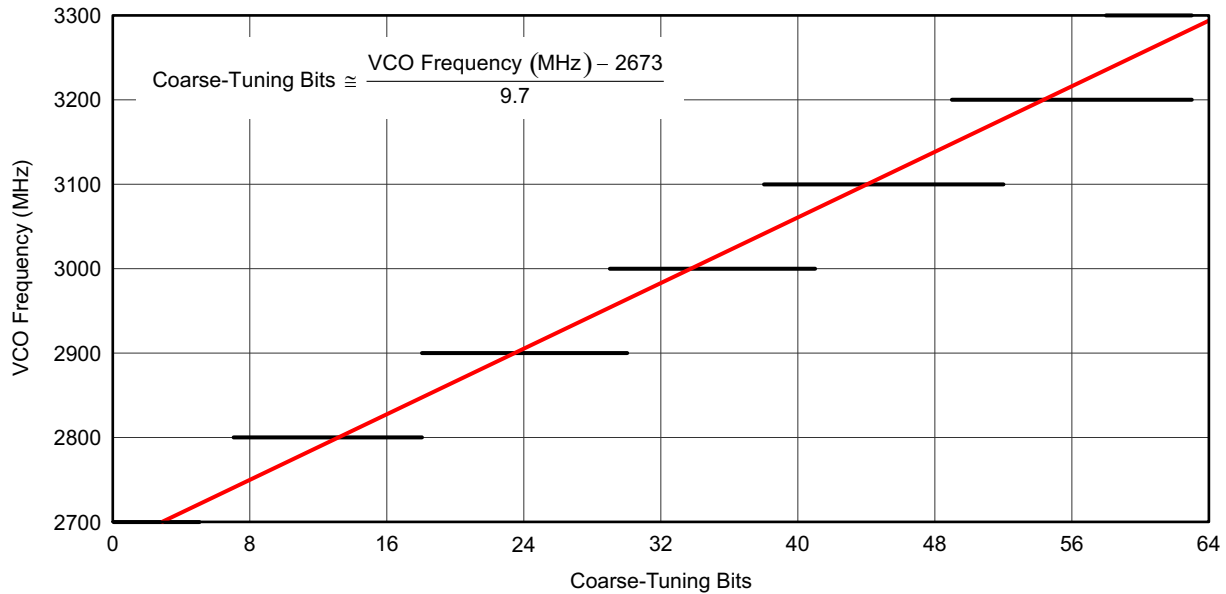

Figure 56. Typical PLL/VCO Lock Range vs Coarse-Tuning Bits

Common wireless infrastructure frequencies (614.4MHz, 737.28MHz, 983.04 MHz, and so forth) are generated from this VCO frequency in conjunction with the prescaler setting as shown in [Table 4](#).

Table 4. VCO Operation

VCO FREQUENCY (MHz)	PRE-SCALE DIVIDER	DESIRED DACCLK (MHz)	pll_p(2:0)
2949.12	6	491.52	110
3072	5	614.4	101
2949.12	4	737.28	100
2949.12	3	983.04	011
2949.12	2	1474.56	010

The M divider is used to determine the phase-frequency-detector (PFD) and charge-pump (CP) frequency.

Table 5. PFD and CP Operation

DACCLK FREQUENCY (MHz)	M DIVIDER	PFD UPDATE RATE (MHz)	pll_m(7:0)
491.52	4	122.88	0000 0100
491.52	8	61.44	0000 1000
491.52	16	30.72	0001 0000
491.52	32	15.36	0010 0000

The N divider in the loop allows the PFD to operate at a lower frequency than the reference clock. Both M and N dividers can keep the PFD frequency below 155 MHz for peak operation.

The overall divide ratio inside the loop is the product of the pre-scale and M dividers ($P \times M$), and the following guidelines should be followed:

- The overall divide ratio range is from 24 to 480.
- When the overall divide ratio is less than 120, the internal loop filter can assure a stable loop.
- When the overall divide ratio is greater than 120, an external loop filter or double charge pump is required to ensure loop stability.

The single- and double-charge-pump current options are selected by setting *pll_cp* in register *config24* to 01 and 11, respectively. When using the double-charge-pump setting, an external loop filter is not required. If an external loop filter is required, the following filter should be connected to the LPF pin (A1):

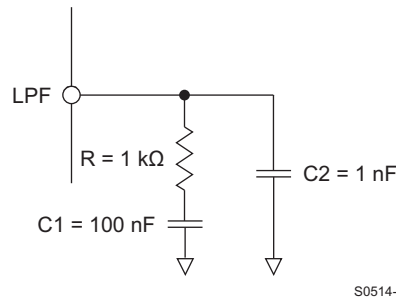

Figure 57. Recommended External Loop Filter

The PLL generates an internal OSTR signal and does not require the external LVPECL OSTR signal. The OSTR signal is buffered from the N-divider output in the PLL block, and the frequency of the signal is the same as the PFD frequency. Therefore, using the PLL with dual-sync-sources mode would require the PFD frequency to be the pre-defined OSTR frequency. This allows the FIFO to be synced correctly by the internal OSTR.

7.3.7 FIR Filters

Figure 58 through Figure 61 show the magnitude spectrum response for the FIR0, FIR1, FIR2 and FIR3 interpolating filters where f_{IN} is the input data rate to the FIR filter. Figure 62 to Figure 65 show the composite filter response for 2x, 4x, 8x and 16x interpolation. The transition band for all interpolation settings is from 0.4 to 0.6 x f_{DATA} (the input data rate to the device) with < 0.001dB of pass-band ripple and > 90 dB stop-band attenuation.

The DAC34SH84 also has a 9-tap inverse sinc filter (FIR4) that runs at the DAC update rate (f_{DAC}) that can be used to flatten the frequency response of the sample-and-hold output. The DAC sample-and-hold output sets the output current and holds it constant for one DAC clock cycle until the next sample, resulting in the well-known $\sin(x) / x$ or $\text{sinc}(x)$ frequency response (Figure 66, red line). The inverse sinc filter response (Figure 66, blue line) has the opposite frequency response from 0 to 0.4 x f_{DAC} , resulting in the combined response (Figure 66, green line). Between 0 to 0.4 x f_{DAC} , the inverse sinc filter compensates the sample-and-hold roll-off with less than 0.03 dB error.

The inverse sinc filter has a gain > 1 at all frequencies. Therefore, the signal input to FIR4 must be reduced from full scale to prevent saturation in the filter. The amount of back-off required depends on the signal frequency, and is set such that at the signal frequencies the combination of the input signal and filter response is less than 1 (0 dB). For example, if the signal input to FIR4 is at 0.25 x f_{DAC} , the response of FIR4 is 0.9 dB, and the signal must be backed off from full scale by 0.9 dB to avoid saturation. The gain function in the QMC blocks can be used to reduce the amplitude of the input signal. The advantage of FIR4 having a positive gain at all frequencies is that the user is then able to optimize the back-off of the signal based on its frequency.

The filter taps for all digital filters are listed in Table 3. Note that the loss of signal amplitude may result in lower SNR due to decrease in signal amplitude.

DAC34SH84

SLAS808E – FEBRUARY 2012 – REVISED SEPTEMBER 2015

www.ti.com

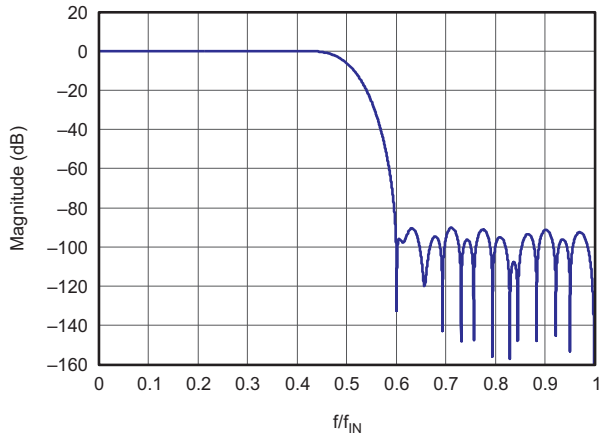

Figure 58. Magnitude Spectrum for FIR0

G048

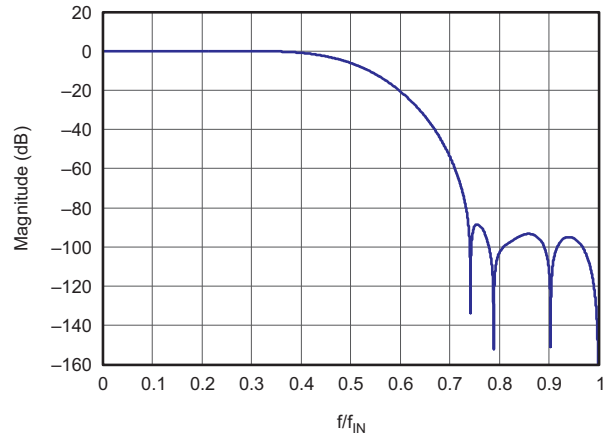

Figure 59. Magnitude Spectrum for FIR1

G049

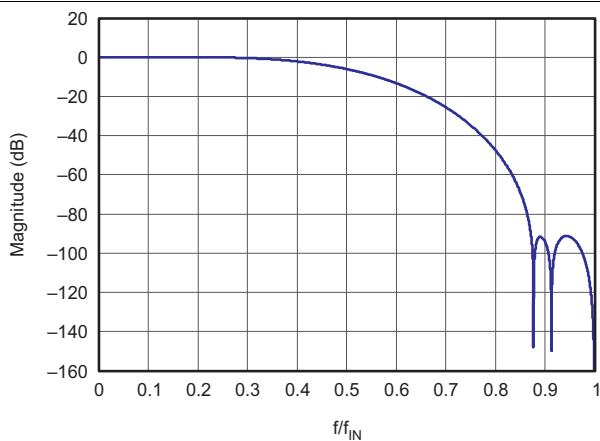

Figure 60. Magnitude Spectrum for FIR2

G050

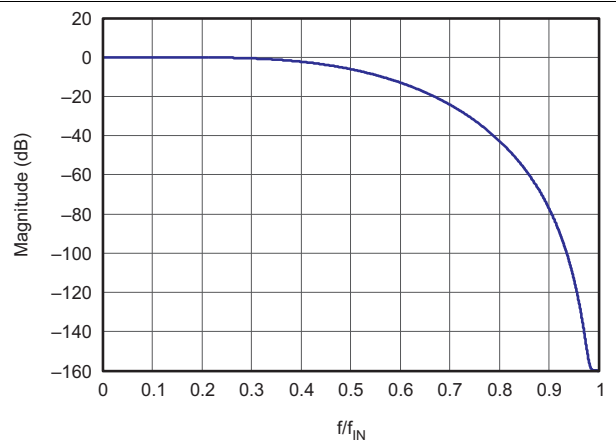

Figure 61. Magnitude Spectrum for FIR3

G051

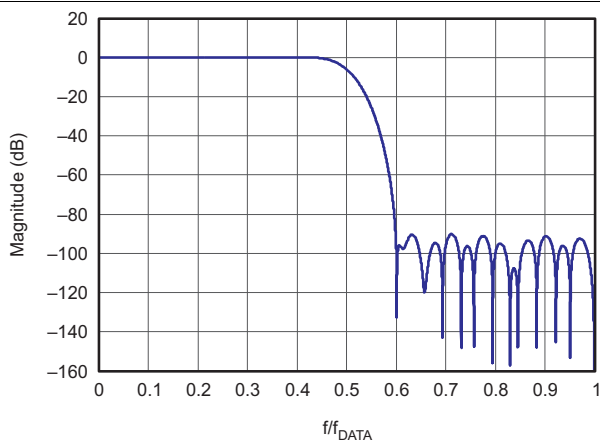

Figure 62. 2x Interpolation Composite Response

G052

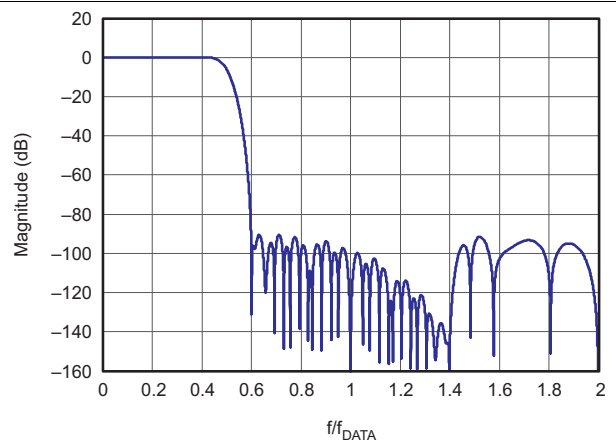

Figure 63. 4x Interpolation Composite Response

G053

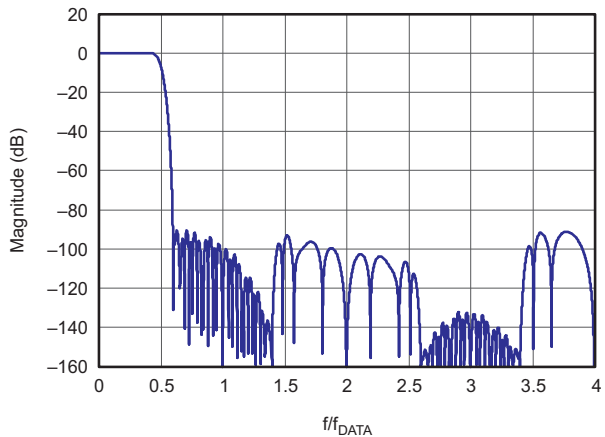

Figure 64. 8x Interpolation Composite Response

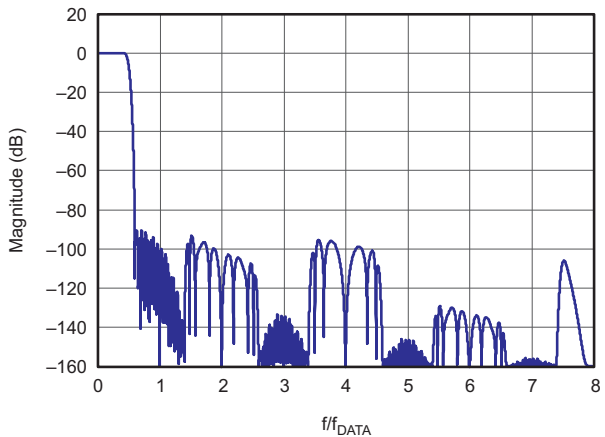

Figure 65. 16x Interpolation Composite Response

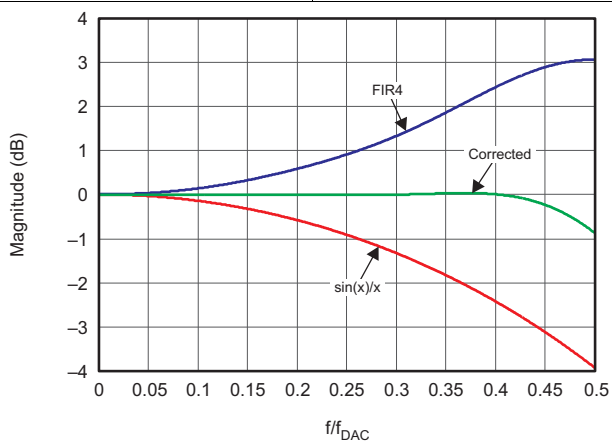

Figure 66. Magnitude Spectrum for Inverse Sinc Filter

Table 6. FIR Filter Coefficients

INTERPOLATING HALF-BAND FILTERS								NON-INTERPOLATING INVERSE-SINC FILTER	
FIR0		FIR1		FIR2		FIR3		FIR4	
59 TAPS		23 TAPS		11 TAPS		11 TAPS		9 TAPS	
6	6	-12	-12	29	29	3	3	1	1
0	0	0	0	0	0	0	0	-4	-4
-19	-19	84	84	-214	-214	-25	-25	13	13
0	0	0	0	0	0	0	0	-50	-50
47	47	-336	-336	1209	1209	150	150	592⁽¹⁾	
0	0	0	0	2048⁽¹⁾		256⁽¹⁾			
-100	-100	1006	1006						
0	0	0	0						
192	192	-2691	-2691						
0	0	0	0						
-342	-342	10141	10141						
0	0	16,384⁽¹⁾							
572	572								
0	0								
-914	-914								
0	0								
1409	1409								
0	0								
-2119	-2119								
0	0								
3152	3152								
0	0								
-4729	-4729								
0	0								
7420	7420								
0	0								
-13,334	-13,334								
0	0								
41,527	41,527								
65,536⁽¹⁾									

(1) Center taps are highlighted in BOLD

7.3.8 Complex Signal Mixer

The DAC34SH84 has two paths of complex signal mixer blocks that contain two full complex mixer (FMIX) blocks and power saving coarse mixer (CMIX) blocks. The signal path is shown in Figure 67.

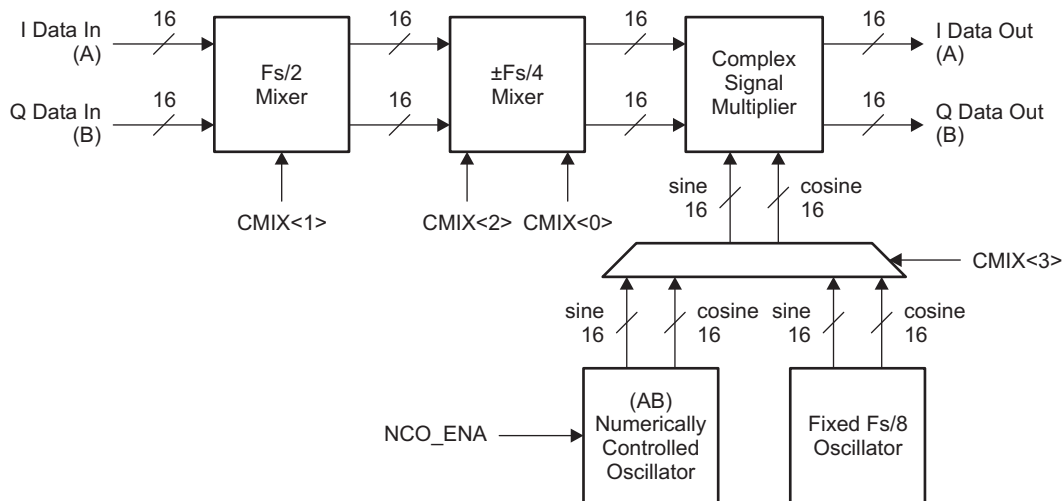

B0471-02

Note: Channel CD data path not shown

Figure 67. Path of Complex Signal Mixer

7.3.8.1 Full Complex Mixer

The two FMIX blocks operate with independent Numerically Controlled Oscillators (NCOs) and enable flexible frequency placement without imposing additional limitations in the signal bandwidth. The NCOs have 32-bit frequency registers (*phaseaddAB(31:0)* and *phaseaddCD(31:0)*) and 16-bit phase registers (*phaseoffsetAB(15:0)* and *phaseoffsetCD(15:0)*) that generate the sine and cosine terms for the complex mixing. The NCO block diagram is shown in Figure 68.

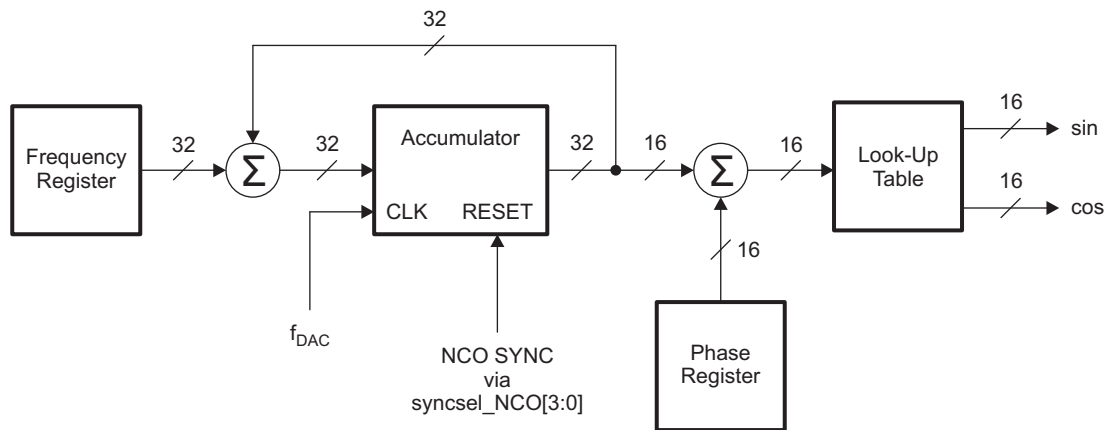

B0026-03

Figure 68. NCO Block Diagram

Synchronization of the NCOs occurs by resetting the NCO accumulators to zero. The synchronization source is selected by *syncsel_NCO(3:0)* in *config31*. The frequency word in the *phaseaddAB(31:0)* and *phaseaddCD(31:0)* registers is added to the accumulators every clock cycle, f_{DAC} . The output frequency of the NCO is:

$$f_{NCO} = \frac{freq \times f_{NCO_CLK}}{2^{32}} \quad (1)$$

With the complex mixer enabled, the two channels in the mixer path are treated as complex vectors of the form $I_{IN}(t) + j Q_{IN}(t)$. The complex signal multiplier (shown in [Figure 69](#)) will multiply the complex channels with the sine and cosine terms generated by the NCO. The resulting output, $I_{OUT}(t) + j Q_{OUT}(t)$, of the complex signal multiplier is:

$$I_{OUT}(t) = (I_{IN}(t)\cos(2\pi f_{NCO}t + \delta) - Q_{IN}(t)\sin(2\pi f_{NCO}t + \delta)) \times 2^{(mixer_gain - 1)}$$

$$Q_{OUT}(t) = (I_{IN}(t)\sin(2\pi f_{NCO}t + \delta) + Q_{IN}(t)\cos(2\pi f_{NCO}t + \delta)) \times 2^{(mixer_gain - 1)}$$

where t is the time since the last resetting of the NCO accumulator, δ is the phase offset value and $mixer_gain$ is either 0 or 1. δ is given by:

$$\delta = 2\pi \times phase_offsetAB/CD(15:0) / 2^{16}$$

The $mixer_gain$ option allows the output signals of the multiplier to reduce by half (6 dB). See [Mixer Gain](#) section for details.

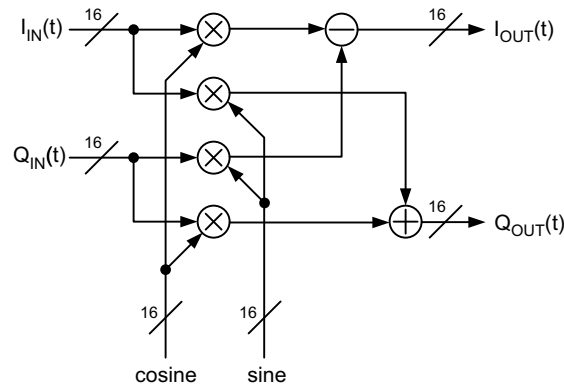

B0472-02

Figure 69. Complex Signal Multiplier

7.3.8.2 Coarse Complex Mixer

In addition to the full complex mixers, the DAC34SH84 also has coarse mixer blocks capable of shifting the input signal spectrum by the fixed mixing frequencies $\pm n \times f_S / 8$. Using the coarse mixer instead of the full mixers lowers power consumption.

The output of the $f_S / 2$, $f_S / 4$, and $-f_S / 4$ mixer block is:

$$I_{OUT}(t) = I(t)\cos(2\pi f_{CMIX}t) - Q(t)\sin(2\pi f_{CMIX}t)$$

$$Q_{OUT}(t) = I(t)\sin(2\pi f_{CMIX}t) + Q(t)\cos(2\pi f_{CMIX}t)$$

Since the sine and the cosine terms are a function of $f_S / 2$, $f_S / 4$, or $-f_S / 4$ mixing frequencies, the possible resulting value of the terms can only be 1, -1, or 0. The simplified mathematics allows the complex signal multiplier to be bypassed in any one of the modes, thus mixer gain is not available. The $f_S / 2$, $f_S / 4$, and $-f_S / 4$ mixer blocks performs mixing through negating and swapping of I/Q channel on certain sequence of samples. [Table 7](#) shows the algorithm used for those mixer blocks.

Table 7. $f_S / 2$, $f_S / 4$, and $-f_S / 4$ Mixing Sequence

MODE	MIXING SEQUENCE
Normal (mixer bypassed)	Iout = {I1, I2, I3, I4...}
	Qout = {Q1, Q2, Q3, Q4...}
$f_S / 2$	Iout = {I1, -I2, I3, -I4...}
	Qout = {Q1, -Q2, Q3, -Q4...}
$f_S / 4$	Iout = {I1, -Q2, -I3, Q4...}
	Qout = {Q1, I2, -Q3, -I4...}
$-f_S / 4$	Iout = {I1, Q2, -I3, -Q4...}
	Qout = {Q1, -I2, -Q3, I4...}

The $f_S / 8$ mixer can be enabled along with various combinations of $f_S / 2$, $f_S / 4$, and $-f_S / 4$ mixer. Because the $f_S / 8$ mixer uses the complex signal multiplier block with fixed $f_S / 8$ sine and cosine term, the output of the multiplier is:

$$I_{OUT}(t) = (I_{IN}(t)\cos(2\pi f_{NCO}t + \delta) - Q_{IN}(t)\sin(2\pi f_{NCO}t + \delta)) \times 2^{(mixer_gain - 1)}$$

$$Q_{OUT}(t) = (I_{IN}(t)\sin(2\pi f_{NCO}t + \delta) + Q_{IN}(t)\cos(2\pi f_{NCO}t + \delta)) \times 2^{(mixer_gain - 1)}$$

where f_{CMIX} is the fixed mixing frequency selected by *cmix(3:0)*. The mixing combinations are described in [Table 8](#). The *mixer_gain* option allows the output signals of the multiplier to reduce by half (6dB). See [Mixer Gain](#) section for details.

Table 8. Coarse Mixer Combinations

cmix(3:0)	$f_S / 8$ MIXER cmix(3)	$f_S / 4$ MIXER cmix(2)	$f_S / 2$ MIXER cmix(1)	$-f_S / 4$ MIXER cmix(0)	MIXING MODE
0000	Disabled	Disabled	Disabled	Disabled	No mixing
0001	Disabled	Disabled	Disabled	Enabled	$-f_S / 4$
0010	Disabled	Disabled	Enabled	Disabled	$f_S / 2$
0100	Disabled	Enabled	Disabled	Disabled	$f_S / 4$
1000	Enabled	Disabled	Disabled	Disabled	$f_S / 8$
1010	Enabled	Disabled	Enabled	Disabled	$-3f_S / 8$
1100	Enabled	Enabled	Disabled	Disabled	$3f_S / 8$
1110	Enabled	Enabled	Enabled	Disabled	$-f_S / 8$
All others	–	–	–	–	Not recommended

7.3.8.3 Mixer Gain

The maximum output amplitude out of the complex signal multiplier (for example, FMIX mode or CMIX mode with $f_S / 8$ mixer enabled) occurs if $I_{IN}(t)$ and $Q_{IN}(t)$ are simultaneously full scale amplitude and the sine and cosine arguments are equal to $2\pi \times f_{MIX}t + \delta (2N-1) \times \pi / 4$, where $N = 1, 2, 3, \dots$

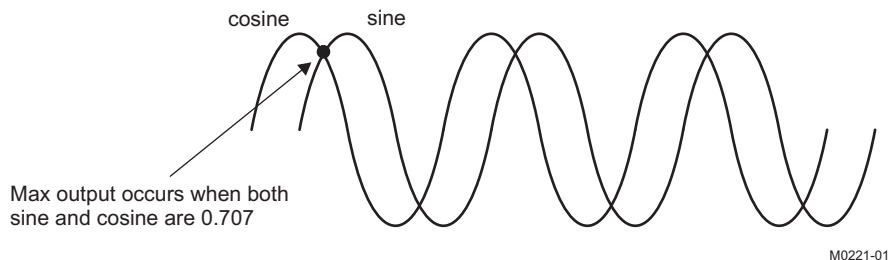

Figure 70. Maximum Output of the Complex Signal Multiplier

With *mixer_gain* = 1 and both $I_{IN}(t)$ and $Q_{IN}(t)$ are simultaneously full scale amplitude, the maximum output possible out of the complex signal multiplier is $0.707 + 0.707 = 1.414$ (or 3dB). This configuration can cause clipping of the signal and should therefore be used with caution.

With *mixer_gain* = 0 in *config2*, the maximum output possible out of the complex signal multiplier is $0.5 \times (0.707 + 0.707) = 0.707$ (or -3 dB). This loss in signal power is in most cases undesirable, and it is recommended that the gain function of the QMC block be used to increase the signal by 3 dB to compensate.

7.3.8.4 Real Channel Upconversion

The mixer in the DAC34SH84 treats the A, B, C, and D inputs are complex input data and produces a complex output for most mixing frequencies. The real input data for each channel can be isolated only when the mixing frequency is set to normal mode or $f_S / 2$ mode. See [Table 7](#) for details.

7.3.9 Quadrature Modulation Correction (QMC)

7.3.9.1 Gain and Phase Correction

The DAC34SH84 includes a Quadrature Modulator Correction (QMC) block. The QMC blocks provide a mean for changing the gain and phase of the complex signals to compensate for any I and Q imbalances present in an analog quadrature modulator. The block diagram for the QMC block is shown in Figure 71. The QMC block contains 3 programmable parameters.

Registers *qmc_gainA/B(10:0)* and *qmc_gainC/D(10:0)* controls the I and Q path gains and is an 11-bit unsigned value with a range of 0 to 1.9990 and the default gain is 1.0000. The implied decimal point for the multiplication is between bit 9 and bit 10.

Register *qmc_phaseAB/CD(11:0)* control the phase imbalance between I and Q and are a 12-bit values with a range of -0.5 to approximately 0.49975 . The QMC phase term is not a direct phase rotation but a constant that is multiplied by each Q sample then summed into the I sample path. This is an approximation of a true phase rotation in order to keep the implementation simple.

LO feed-through can be minimized by adjusting the DAC offset feature described below.

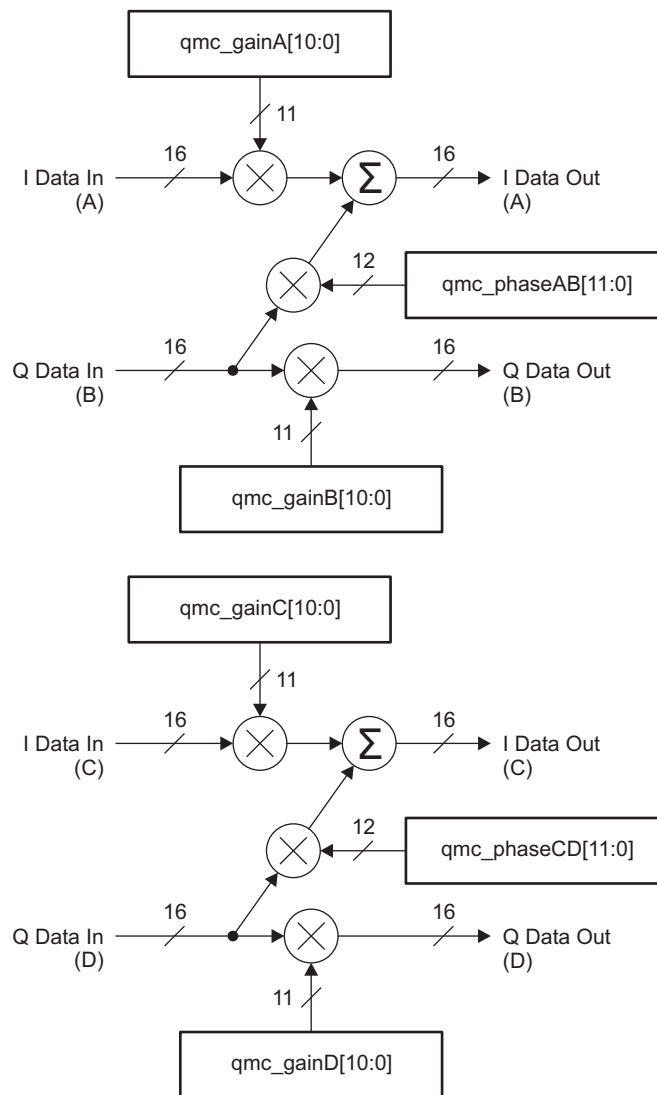

B0164-03

Figure 71. QMC Block Diagram

7.3.9.2 Offset Correction

Registers *qmc_offsetA(12:0)*, *qmc_offsetB(12:0)*, *qmc_offsetC(12:0)* and *qmc_offsetD(12:0)* can be used to independently adjust the dc offsets of each channel. The offset values are represented in 2s-complement format with a range from -4096 to 4095.

The offset value adds a digital offset to the digital data before digital-to-analog conversion. Because the offset is added directly to the data it may be necessary to back off the signal to prevent saturation. Both data and offset values are LSB aligned.

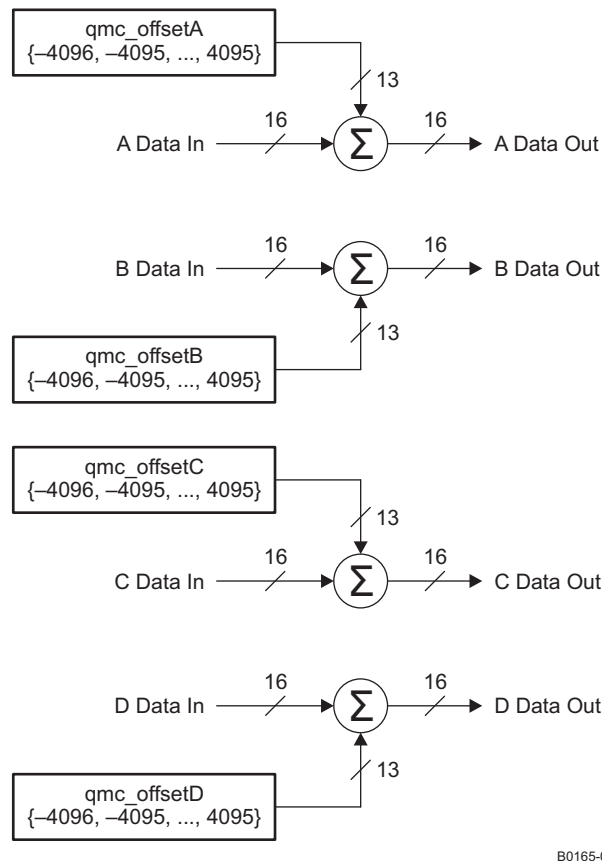

B0165-03

Figure 72. Digital Offset Block Diagram

7.3.10 Temperature Sensor

The DAC34SH84 incorporates a temperature sensor block which monitors the temperature by measuring the voltage across 2 transistors. The voltage is converted to an 8-bit digital word using a successive-approximation (SAR) analog to digital conversion process. The result is scaled, limited and formatted as a 2s-complement value representing the temperature in degrees Celsius.

The sampling is controlled by the serial interface signals SDENB and SCLK. If the temperature sensor is enabled (*tsense_sleep* = 0 in register *config26*) a conversion takes place each time the serial port is written or read. The data is only read and sent out by the digital block when the temperature sensor is read in *tempdata(7:0)* in *config6*. The conversion uses the first eight clocks of the serial clock as the capture and conversion clock, the data is valid on the falling eighth SCLK. The data is then clocked out of the chip on the rising edge of the ninth SCLK. No other clocks to the chip are necessary for the temperature sensor operation. As a result the temperature sensor is enabled even when the device is in sleep mode.

In order for the process described above to operate properly, the serial port read from *config6* must be done with an SCLK period of at least 1 μ s. If this is not satisfied the temperature sensor accuracy is greatly reduced.

7.3.11 Data Pattern Checker

The DAC34SH84 incorporates a simple pattern checker test in order to determine errors in the data interface. The main cause of failures is setup and/or hold timing issues. The test mode is enabled by asserting *iotest_ena* in register *config1*. In test mode the analog outputs are deactivated regardless of the state of TXENA or *sif_textnable* in register *config3*.

The data pattern key used for the test is 8 words long and is specified by the contents of *iotest_pattern[0:7]* in registers *config37* through *config44*. The data pattern key can be modified by changing the contents of these registers.

The first word in the test frame is determined by a rising edge transition in ISTR or SYNC, depending on the *syncsel_fifo(3:0)* setting in *config32*. At this transition, the *pattern0* word should be input to the data DAB[15:0] pins, and *pattern2* should be input to the data DCD[15:0] pins. Patterns 1, 4, and 5 of DAB[15:0] bus and pattern 3, 6, and 7 of DCD[15:0] bus should follow sequentially on each edge of DATACLK (rising and falling). The sequence should be repeated until the pattern checker test is disabled by setting *iotest_ena* back to 0. It is not necessary to have a rising ISTR or SYNC edge aligned with every four DATACLK cycle, just the first one to mark the beginning of the series.

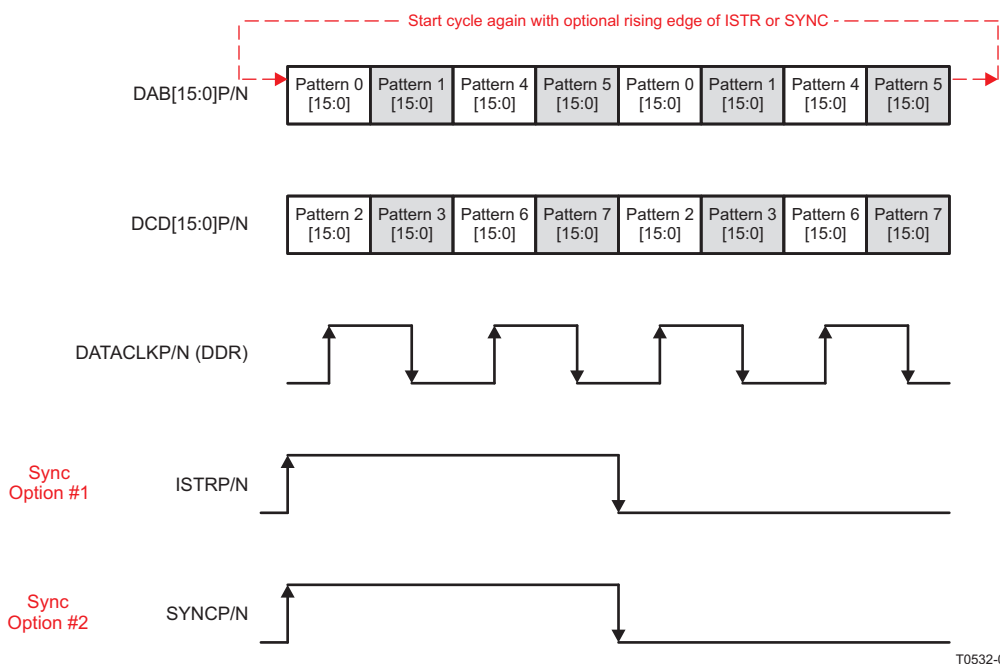

Figure 73. I/O Pattern Checker Data Transmission Format

The test mode determines if all the patterns on the two 16-bit LVDS data buses (DAB[15:0]P/N and DCD[15:0]P/N) were received correctly by comparing the received data against the data pattern key. If any bits in either of the two 16-bit data buses were received incorrectly, the corresponding bits in *iotest_results(15:0)* in register *config4* will be set to 1 to indicate bit error location. The user can check the corresponding bit location on both 16-bit data buses and implement the fix accordingly. Furthermore, the error condition will trigger the *alarm_from_iotest* bit in register *config5* to indicate a general error in the data interface. When data pattern checker mode is enabled, this alarm in register *config5*, bit7 is the only valid alarm. Other alarms in register *config5* are not valid and can be disregarded.

For instance, *pattern0* is programmed to the default of 0x7A7A. If the received Pattern 0 is 0x7A7B, then bit 0 in *iotest_results(15:0)* will be set to 1 to indicate an error in bit 0 location. The *alarm_from_iotest* will also be set to 1 to report the data transfer error. Note that *iotest_results(15:0)* does not indicate which of the 16-bit buses has the error. The user needs to check both 16-bit buses and then narrow down the error from the bit location information.

The alarms can be cleared by writing 0x0000 to *iotest_results(15:0)* and 0 to *alarm_from_iotest* through the serial interface. The serial interface will read back 0s if there are no errors or if the errors are cleared. The corresponding alarm bit will remain a 1 if the errors remain.

It is recommended to enable the pattern checker and then run the pattern sequence for 100 or more complete cycles before clearing the *iotest_results(15:0)* and *alarm_from_iotest*. This will eliminate the possibility of false alarms generated during the setup sequence. Based on the pattern test result, the user can adjust the data source output timing, PCB traces delay, or DAC34SH84 CONFIG36 LVDS programmable delay to help optimize the setup and hold time of the transmitter system.

DAC34SH84

SLAS808E –FEBRUARY 2012–REVISED SEPTEMBER 2015

www.ti.com

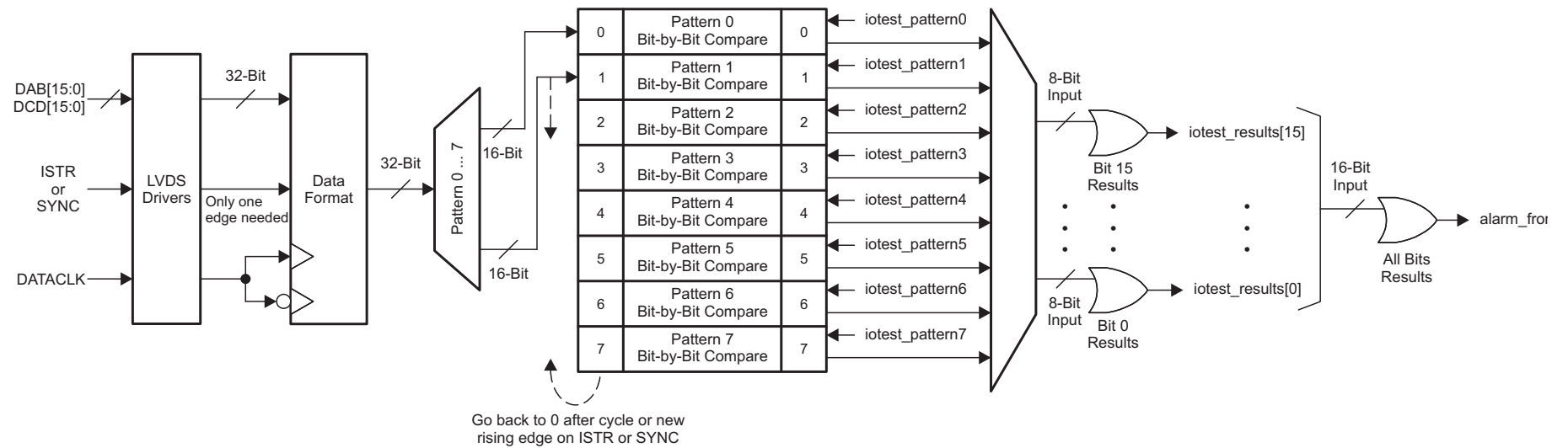

Figure 74. DAC34SH84 Pattern Check Block Diagram

7.3.12 Parity Check Test

The DAC34SH84 has a parity check test that enables continuous validity monitoring of the data received by the DAC. Parity check testing in combination with the data pattern checker offer an excellent solution for detecting board assembly issues due to missing pad connections.

For the parity check test, an extra parity bit is added to the data bits to ensure that the total number of set bits (bits with value 1) is even or odd. This simple scheme is used to detect single or any other odd number of data transfer errors. Parity testing is implemented in the DAC34SH84 in two ways: 32-bit parity and dual 16-bit parity.

7.3.12.1 32-Bit Parity

In the 32-bit mode the additional parity bit is sourced to the parity input (PARITYP/N) for the 32-bit data transfer into the DAB[15:0]P/N and DCD[15:0]P/N inputs. This mode is enabled by setting *parity_ena* = 1 and *single_dual_parity* = 0 in register *config1*. The input parity value is defined to be the total number of logic 1s on the 33-bit data bus – the DAB[15:0]P/N inputs, the DCD[15:0]P/N inputs, and the PARITYP/N input. This value, the total number of logic 1s, must match the parity test selected in the *oddeven_parity* bit in register *config1*.

For example, if the *oddeven_parity* bit is set to 1 for odd parity, then the number of 1s on the 33-bit data bus should be odd. The DAC will check the data transfer through the parity input. If the data received has odd number of 1s, then the parity is correct. If the data received has even number of 1s, then the parity is incorrect. The corresponding alarm for parity error will be set accordingly.

Figure 75 shows the simple XOR structure used to check word parity. Parity is tested independently for data captured on both rising and falling edges of DATACLK (*alarm_Aparity* and *alarm_Bparity*, respectively). Testing on both edges helps in determining a possible setup or hold issue. Both alarms are captured individually in register *config5*.

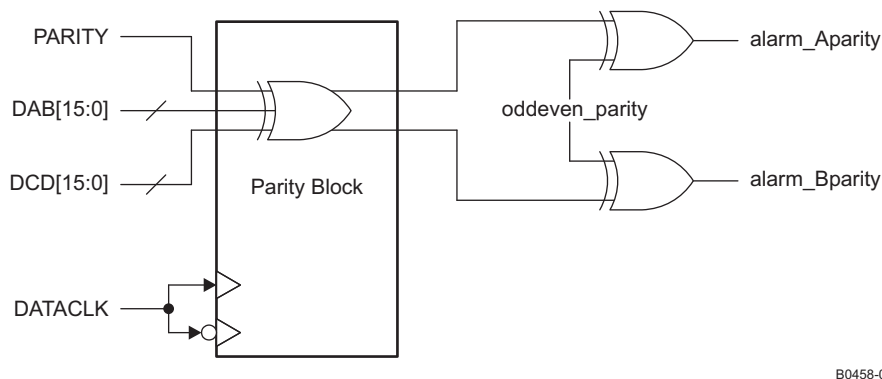

Figure 75. DAC34SH84 32-Bit Parity Check

7.3.12.2 Dual 16-Bit Parity

In the dual 16-bit mode, each 16-bit LVDS data bus input will be accompanied by a parity bit for error checking. The DAB[15:0]P/N and ISTRP/N are one 17-bit data path, and the DCD[15:0]P/N and PARITYP/N are another path. This mode is enabled by setting *parity_ena* = 1 and *single_dual_parity* = 1 in register *config1*. The input parity value is defined to be the total number of logic 1s on each 17-bit data bus. This value, the total number of logic 1s, must match the parity test selected in the *oddeven_parity* bit in register *config1*.

For example, if the *oddeven_parity* bit is set to 1 for odd parity, then the number of 1s on each 17-bit data bus should be odd. The DAC will check the data transfer through the parity input. If the data received has odd number of 1s, then the parity is correct. If the data received has even number of 1s, then the parity is incorrect. The corresponding alarm for parity error will be set accordingly.

Figure 76 shows the simple XOR structure used to check word parity. Parity is tested independently for data captured on both rising and falling edges of DATACLK for each data path (*alarm_Aparity*, *alarm_Bparity*, *alarm_Cparity*, and *alarm_Dparity*, respectively). Testing on both edges and both data buses helps in determining a possible setup or hold issue. All of the alarms are captured individually in register *config5*.

In this mode the ISTR signal functions as a parity signal and cannot be used to sync the FIFO pointer simultaneously. It is recommended to use the SYNC to sync the FIFO pointer. If ISTR has to be used to sync the FIFO pointer, the ISTR sync can only be possible upon start-up when dual 16-bit parity function is disabled. Once the initialization is finished, disable the FIFO pointer sync through ISTR (by configuring *syncsel_fifo_in* and *syncsel_fifo_out* in *config32*) and enable the dual 16-bit parity function afterwards.

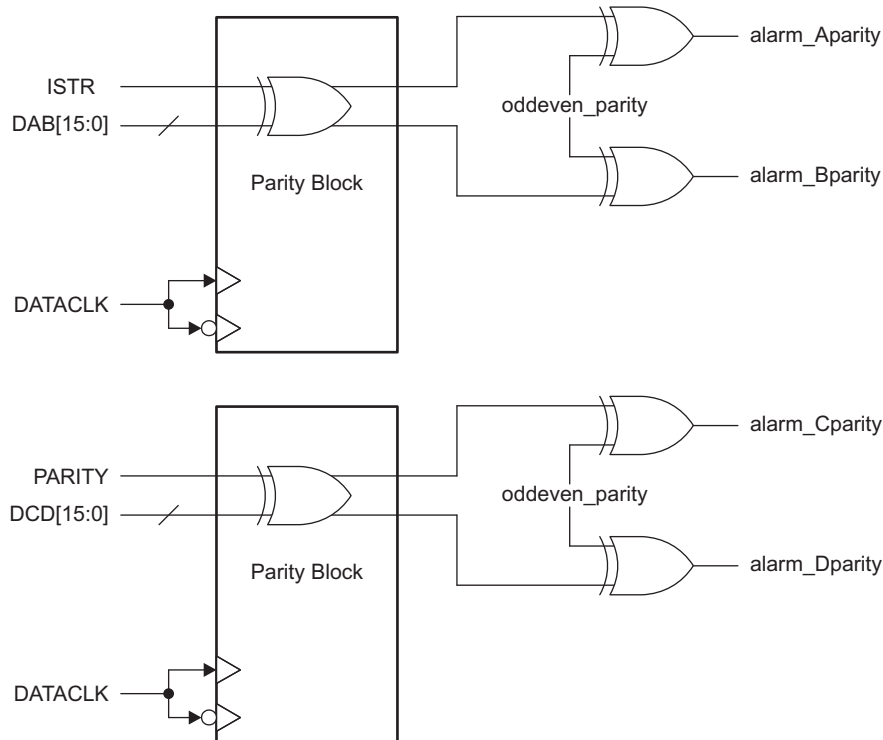

B0463-01

Figure 76. DAC34SH84 Dual 16-Bit Parity Check

7.3.13 DAC34SH84 Alarm Monitoring

The DAC34SH84 includes a flexible set of alarm monitoring that can be used to alert of a possible malfunction scenario. All the alarm events can be accessed either through the *config5* register or through the ALARM pin. Once an alarm is set, the corresponding alarm bit in register *config5* must be reset through the serial interface to allow further testing. The set of alarms includes the following conditions:

Zero check alarm

- **Alarm_from_zerochk.** Occurs when the FIFO write pointer has an all zeros pattern. Since the write pointer is a shift register, all zeros will cause the input point to be stuck until the next sync event. When this happens a sync to the FIFO block is required.

FIFO alarms

- **alarm_from_fifo.** Occurs when there is a collision in the FIFO pointers or a collision event is close.
 - **alarm_fifo_2away.** Pointers are within two addresses of each other.
 - **alarm_fifo_1away.** Pointers are within one address of each other.
 - **alarm_fifo_collision.** Pointers are equal to each other.

Clock alarms

- **clock_gone.** Occurs when either the DACCLK or DATACLK have been stopped.
 - **alarm_dacclk_gone.** Occurs when the DACCLK has been stopped.
 - **alarm_dataclk_gone.** Occurs when the DATACLK has been stopped.

Pattern checker alarm

- **alarm_from_iotest.** Occurs when the input data pattern does not match the pattern key.

PLL alarm

- alarm_from_pll. Occurs when the PLL is out of lock.

Parity alarms

- alarm_Aparity: In dual parity mode, alarm indicating a parity error on the A word. In single parity mode, alarm on the 32-bit data captured on the rising edge of DATACLKP/N.
- alarm_Bparity: In dual parity mode, alarm indicating a parity error on the B word. In single parity mode, alarm on the 32-bit data captured on the falling edge of DATACLKP/N.
- alarm_Cparity: In dual parity mode, alarm indicating a parity error on the C word.
- alarm_Dparity: In dual parity mode, alarm indicating a parity error on the D word.

To prevent unexpected DAC outputs from propagating into the transmit channel chain, the clock and alarm_fifo_collision alarms can be set in *config2* to shut-off the DAC output automatically regardless of the state of TXENA or *sif_txenable*.

Alarm monitoring is implemented as follows:

- Power up the device using the recommended power-up sequence.
- Clear all the alarms in *config5* by setting them to zeros.
- Unmask those alarms that will generate a hardware interrupt through the ALARM pin in *config7*.
- Enable automatic DAC shut-off in register *config2* if required.
- In the case of an alarm event, the ALARM pin will trigger. If automatic DAC shut-off has been enabled the DAC outputs will be disabled.
- Read registers *config5* to determine which alarm triggered the ALARM pin.
- Correct the error condition and re-synchronize the FIFO.
- Clear the alarms in *config5*.
- Re-read *config5* to ensure the alarm event has been corrected.
- Keep clearing and reading *config5* until no error is reported.

7.3.14 LVPECL Inputs

Figure 77 shows an equivalent circuit for the DAC input clock (DACCLKP/N) and the output strobe clock (OSTRP/N).

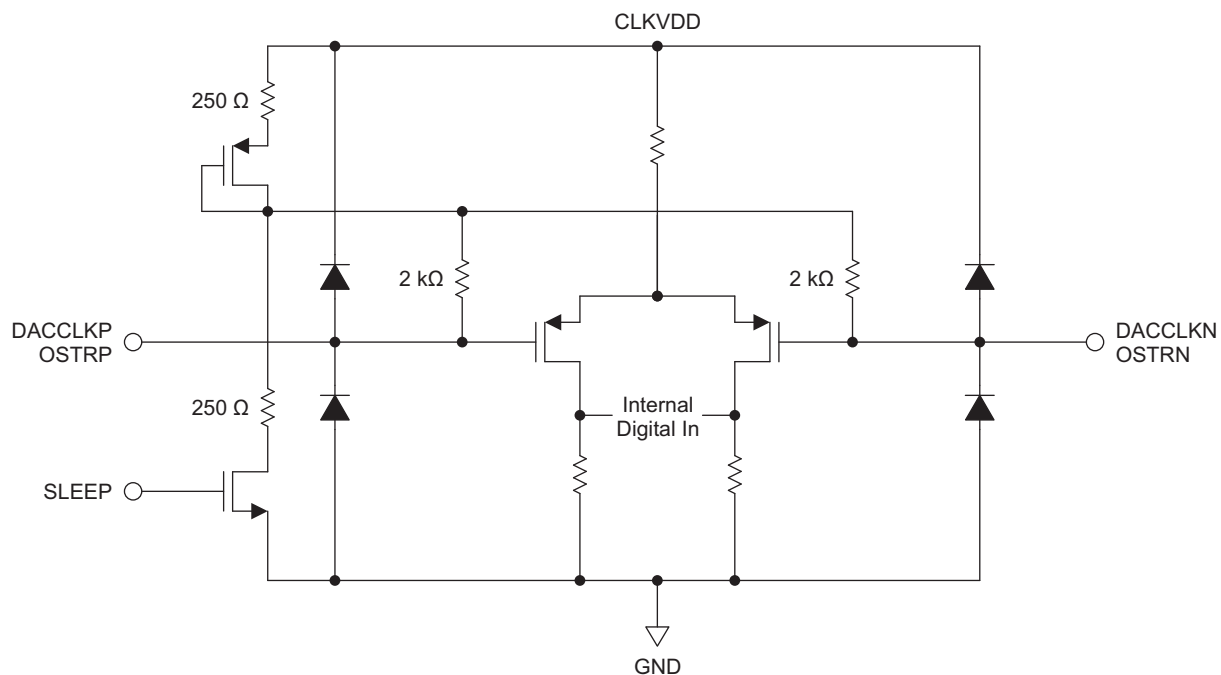

S0515-01

Figure 77. DACCLKP/N and OSTRP/N Equivalent Input Circuit

Figure 78 shows the preferred configuration for driving the CLKIN/CLKINC input clock with a differential ECL or PECL source.

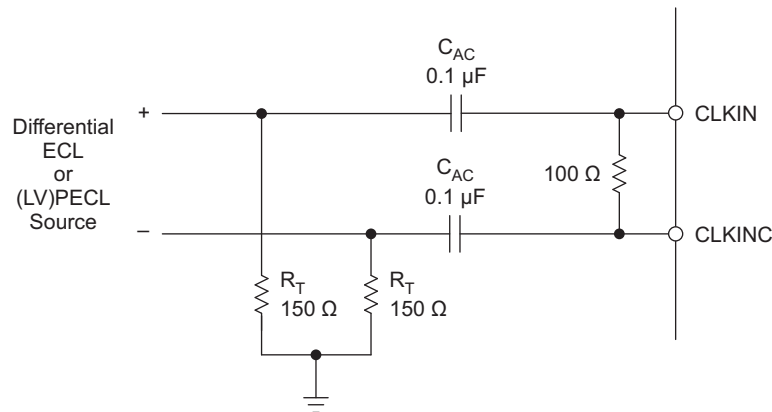

S0029-02

Figure 78. Preferred Clock Input Configuration With a Differential ECL or PECL Clock Source

7.3.15 LVDS Inputs

The DAB[15:0]P/N, DCD[15:0]P/N, DATACLKP/N, SYNCN/P, PARITYP/N, and ISTRP/N LVDS pairs have the input configuration shown in Figure 79. Figure 80 shows the typical input levels and common-mode voltage used to drive these inputs.

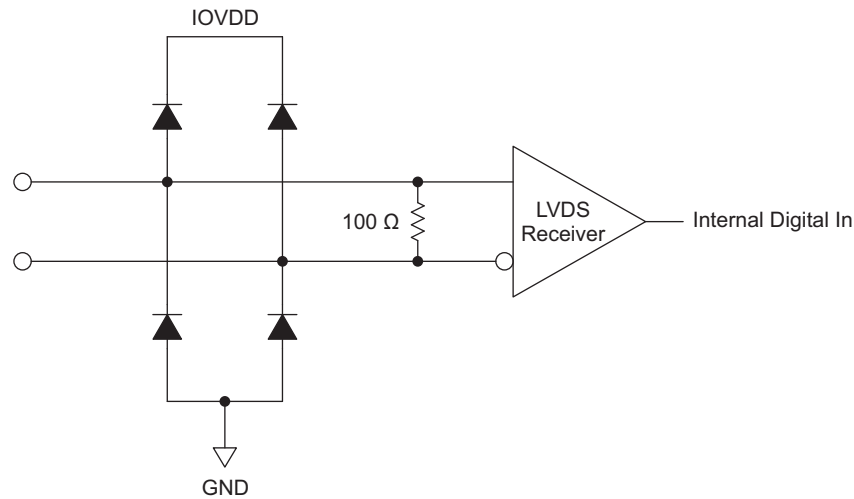

S0516-01

Figure 79. DAB[15:0]P/N, DCD[15:0]P/N, DATACLKP/N, ISTRP/N, SYNCN/P and PARITYP/N LVDS Input Configuration

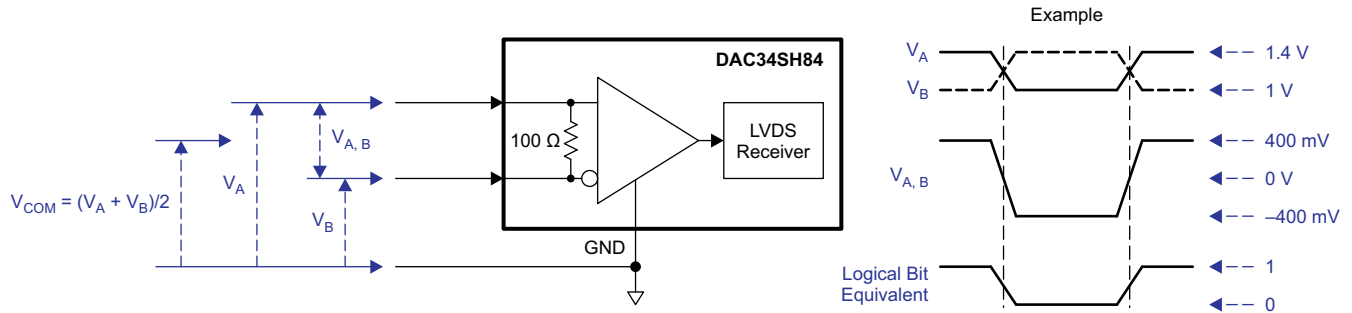

Figure 80. LVDS Data Input Levels

Table 9. Example LVDS Data Input Levels

APPLIED VOLTAGES		RESULTING DIFFERENTIAL VOLTAGE	RESULTING COMMON-MODE VOLTAGE	LOGICAL BIT BINARY EQUIVALENT
VA	VB	VA,B	VCOM	
1.4 V	1.0 V	400 mV	1.2 V	1
1.0 V	1.4 V	-400 mV		0
1.2 V	0.8 V	400 mV	1.0 V	1
0.8 V	1.2 V	-400 mV		0

7.3.16 CMOS Digital Inputs

Figure 81 shows a schematic of the equivalent CMOS digital inputs of the DAC34SH84. SDIO, SCLK, SLEEP and TXENA have pull-down resistors while SDENB and RESETB have pull-up resistors internal to the DAC34SH84. All the CMOS digital inputs and outputs are referred to the IOVDD2 supply, which can vary from 1.8 V to 3.3 V. This facilitates the I/O interface and eliminates the need of level translation. See *Electrical Characteristics – Digital Specifications* for logic thresholds. The pull-up and pull-down circuitry is approximately equivalent to 100 kΩ.

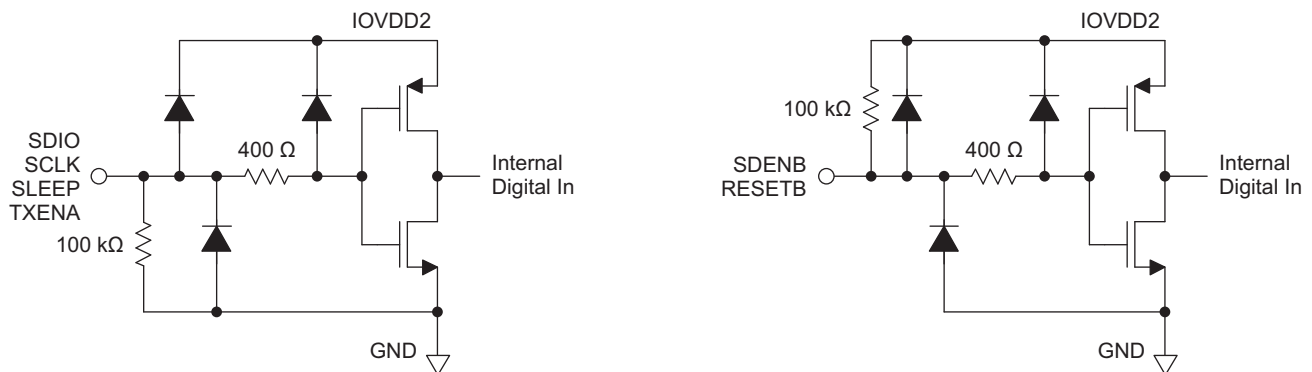

Figure 81. CMOS Digital Equivalent Input

7.3.17 Reference Operation

The DAC34SH84 uses a bandgap reference and control amplifier for biasing the full-scale output current. The full-scale output current is set by applying an external resistor R_{BIAS} to pin BIASJ. The bias current I_{BIAS} through resistor R_{BIAS} is defined by the on-chip bandgap reference voltage and control amplifier. The default full-scale output current equals 64 times this bias current and can thus be expressed as:

$$I_{OUTFS} = 64 \times I_{BIAS} = 64 \times (V_{EXTIO} / R_{BIAS}) / 2$$

The DAC34SH84 has a 4-bit coarse gain control $coarse_dac(3:0)$ in the $config3$ register. Using gain control, the $IOUT_{FS}$ can be expressed as:

$$IOUT_{FS} = (coarse_dac + 1) / 16 \times I_{BIAS} \times 64 = (coarse_dac + 1) / 16 \times (V_{EXTIO} / R_{BIAS}) / 2 \times 64$$

where V_{EXTIO} is the voltage at terminal EXTIO. The bandgap reference voltage delivers an accurate voltage of 1.2 V. This reference is active when $extref_ena = 0$ in $config27$. An external decoupling capacitor C_{EXT} of 0.1 μ F should be connected externally to terminal EXTIO for compensation. The bandgap reference can additionally be used for external reference operation. In that case, an external buffer with high impedance input should be applied in order to limit the bandgap load current to a maximum of 100 nA. The internal reference can be disabled and overridden by an external reference by setting the $extref_ena$ control bit. Capacitor C_{EXT} may hence be omitted. Terminal EXTIO thus serves as either input or output node.

The full-scale output current can be adjusted from 30 mA down to 10 mA by varying resistor R_{BIAS} , programming $coarse_dac(3:0)$, or changing the externally applied reference voltage.

NOTE

With internal reference, the minimum R_{bias} resistor value is 1.28 k Ω . Resistor value below 1.28 k Ω is not recommended since it will program the full-scale current to go above 30 mA and potentially damages the device.

7.3.18 DAC Transfer Function

The CMOS DACs consist of a segmented array of PMOS current sources, capable of sourcing a full-scale output current up to 30 mA. Differential current switches direct the current to either one of the complementary output nodes IOUTP or IOUTN. Complementary output currents enable differential operation, thus canceling out common mode noise sources (digital feed-through, on-chip and PCB noise), dc offsets, even order distortion components, and increasing signal output power by a factor of two.

The full-scale output current is set using external resistor R_{BIAS} in combination with an on-chip bandgap voltage reference source (+1.2 V) and control amplifier. Current I_{BIAS} through resistor R_{BIAS} is mirrored internally to provide a maximum full-scale output current equal to 64 times I_{BIAS} .

The relation between IOUTP and IOUTN can be expressed as:

$$IOUT_{FS} = IOUTP + IOUTN$$

We will denote current flowing into a node as – current and current flowing out of a node as + current. Since the output stage is a current source the current flows from the IOUTP and IOUTN pins. The output current flow in each pin driving a resistive load can be expressed as:

$$IOUTP = IOUT_{FS} \times CODE / 65,536$$

$$IOUTN = IOUT_{FS} \times (65,535 - CODE) / 65,536$$

where CODE is the decimal representation of the DAC data input word

For the case where IOUTP and IOUTN drive resistor loads R_L directly, this translates into single ended voltages at IOUTP and IOUTN:

$$VOUTP = IOUT1 \times R_L$$

$$VOUTN = IOUT2 \times R_L$$

Assuming that the data is full scale (65,535 in offset binary notation) and the R_L is 25 Ω , the differential voltage between pins IOUTP and IOUTN can be expressed as:

$$VOUTP = 20\text{mA} \times 25 \Omega = 0.5 \text{ V}$$

$$VOUTN = 0\text{mA} \times 25 \Omega = 0 \text{ V}$$

$$VDIFF = VOUTP - VOUTN = 0.5\text{V}$$

Note that care should be taken not to exceed the compliance voltages at node IOUTP and IOUTN, which would lead to increased signal distortion.

7.3.19 Analog Current Outputs

The DAC34SH84 can be easily configured to drive a doubly terminated 50-Ω cable using a properly selected RF transformer. Figure 82 and Figure 83 show the 50-Ω doubly terminated transformer configuration with 1:1 and 4:1 impedance ratio, respectively. Note that the center tap of the primary input of the transformer has to be grounded to enable a DC current flow. Applying a 20-mA full-scale output current would lead to a 0.5 V_{pp} for a 1:1 transformer and a 1-V_{pp} output for a 4:1 transformer. The low dc-impedance between IOU_{TP} or IOU_{TN} and the transformer center tap sets the center of the ac-signal to GND, so the 1 V_{pp} output for the 4:1 transformer results in an output between –0.5 V and +0.5 V.

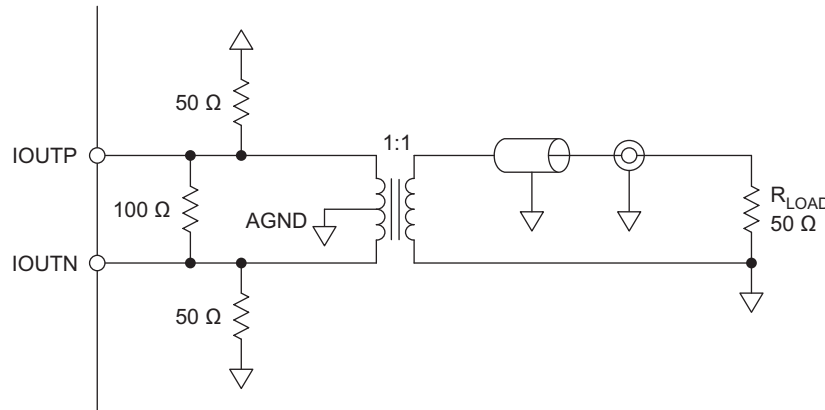

S0517-01

Figure 82. Driving a Doubly Terminated 50-Ω Cable Using a 1:1 Impedance Ratio Transformer

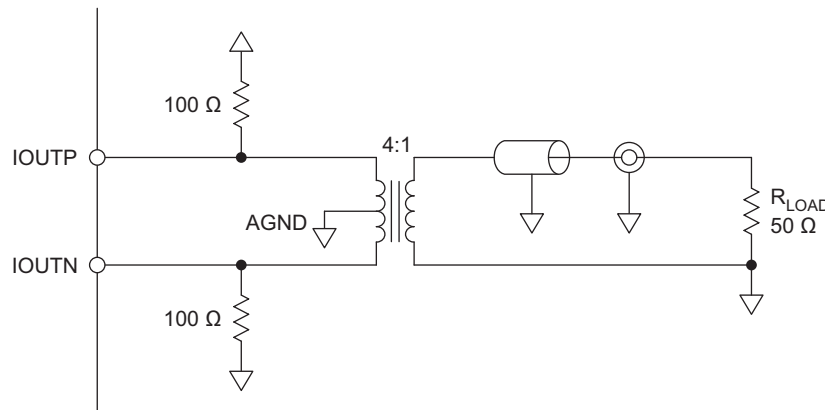

S0518-01

Figure 83. Driving a Doubly Terminated 50-Ω Cable Using a 4:1 Impedance Ratio Transformer

7.4 Device Functional Modes

7.4.1 Multi-Device Synchronization

In various applications, such as multi antenna systems where the various transmit channels information is correlated, it is required that multiple DAC devices are completely synchronized such that their outputs are phase aligned. The DAC34SH84 architecture supports this mode of operation.

7.4.1.1 Multi-Device Synchronization: PLL Bypassed with Dual Sync Sources Mode

For single- or multi-device synchronization it is important that delay differences in the data are absorbed by the device so that latency through the device remains the same. Furthermore, to ensure that the outputs from each DAC are phase aligned it is necessary that data is read from the FIFO of each device simultaneously. In the DAC34SH84 this is accomplished by operating the multiple devices in Dual Sync Sources mode. In this mode the additional OSTR signal is required by each DAC34SH84 to be synchronized.

Device Functional Modes (continued)

Data into the device is input as LVDS signals from one or multiple baseband ASICs or FPGAs. Data into multiple DAC devices can experience different delays due to variations in the digital source output paths or board level wiring. These different delays can be effectively absorbed by the DAC34SH84 FIFO so that all outputs are phase aligned correctly.

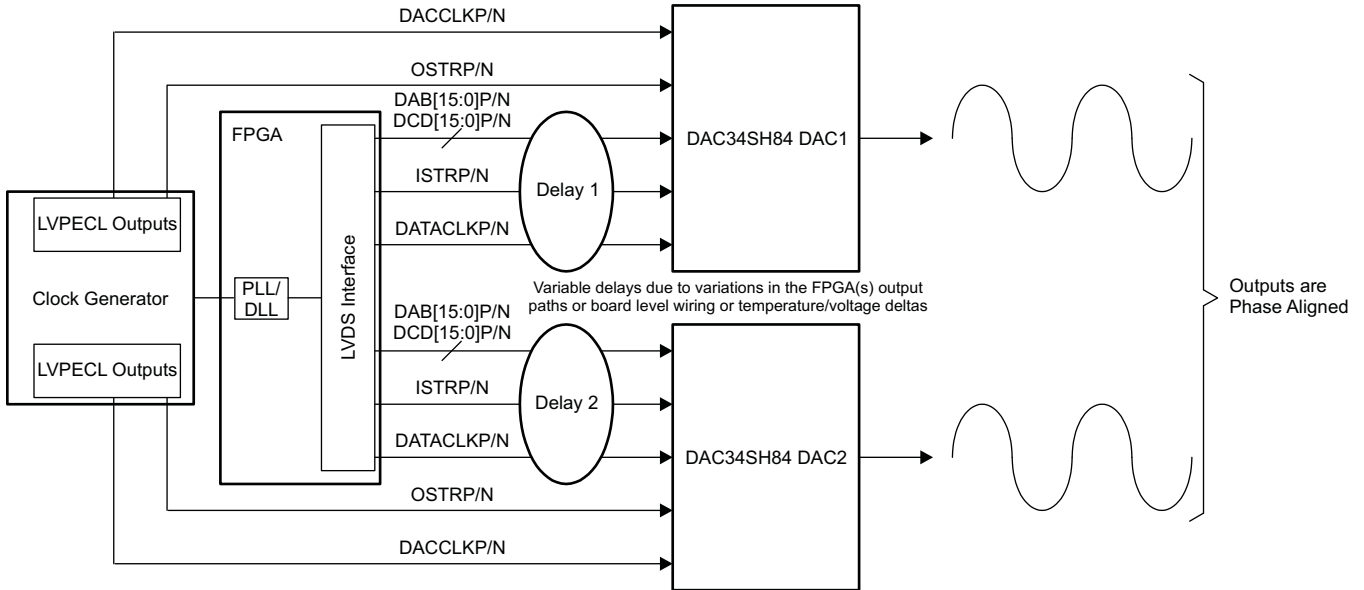

B0454-04

Figure 84. Synchronization System in Dual Sync Sources Mode With PLL Bypassed

For correct operation both OSTR and DACCLK must be generated from the same clock domain. The OSTR signal is sampled by DACCLK and must satisfy the timing requirements in the specifications table. If the clock generator does not have the ability to delay the DACCLK to meet the OSTR timing requirement, the polarity of the DACCLK outputs can be swapped with respect to the OSTR ones to create 180 degree phase delay of the DACCLK. This may help establish proper setup and hold time requirement of the OSTR signal.

Careful board layout planning must be done to ensure that the DACCLK and OSTR signals are distributed from device to device with the lowest skew possible as this will affect the synchronization process. In order to minimize the skew across devices it is recommended to use the same clock distribution device to provide the DACCLK and OSTR signals to all the DAC devices in the system.

Device Functional Modes (continued)

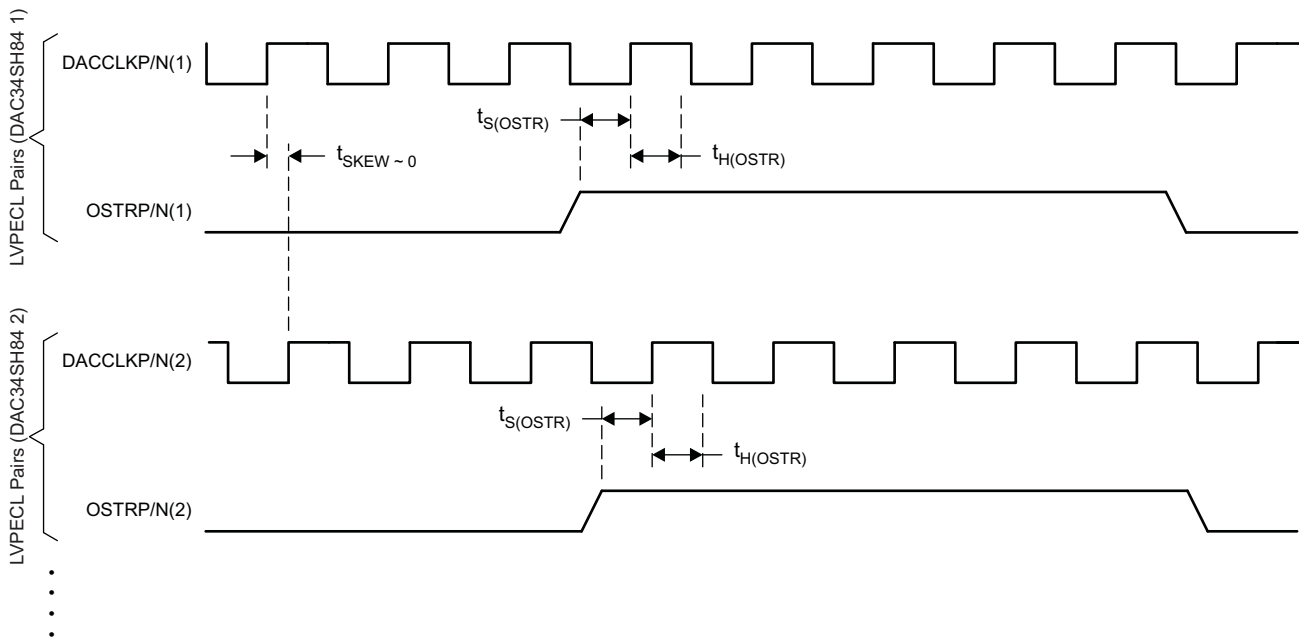

T0526-04

Figure 85. Timing Diagram for LVPECL Synchronization Signals

The following steps are required to ensure the devices are fully synchronized. The procedure assumes all the DAC34SH84 devices have a DACCLK and OSTR signal and must be carried out on each device.

1. Start-up the device as described in the power-up sequence. Set the DAC34SH84 in Dual Sync Sources mode and select OSTR as the clock divider sync source (*clkdiv_sync_sel* in register *config32*).
2. Sync the clock divider and FIFO pointers.
3. Verify there are no FIFO alarms either through register *config5* or through the ALARM pin.
4. Disable clock divider sync by setting *clkdiv_sync_ena* to 0 in register *config0*.

After these steps all the DAC34SH84 outputs will be synchronized.

7.4.1.2 Multi-Device Synchronization: PLL Enabled with Dual Sync Sources Mode

The DAC34SH84 allows exact phase alignment between multiple devices even when operating with the internal PLL clock multiplier. In PLL clock mode, the PLL generates the DAC clock and an internal OSTR signal from the reference clock applied to the DACCLK inputs so there is no need to supply an additional LVPECL OSTR signal.

For this method to operate properly the SYNC signal should be set to reset the PLL N dividers to a known state by setting *pll_ndivsync_ena* in register *config24* to 1. The SYNC signal resets the PLL N dividers with a rising edge, and the timing relationship $t_{s(SYNC_PLL)}$ and $t_{h(SYNC_PLL)}$ are relative to the reference clock presented on the DACCLK pin.

Both SYNC and DACCLK can be set as low frequency signals to greatly simplifying trace routing (SYNC can be just a pulse as a single rising edge is required, if using a periodic signal it is recommended to clear the *pll_ndivsync_ena* bit after resetting the PLL dividers). Besides the $t_{s(SYNC_PLL)}$ and $t_{h(SYNC_PLL)}$ requirement between SYNC and DACCLK, there is no additional required timing relationship between the SYNC and ISTR signals or between DACCLK and DATACLK. The only restriction as in the PLL disabled case is that the DACCLK and SYNC signals are distributed from device to device with the lowest skew possible.

Device Functional Modes (continued)

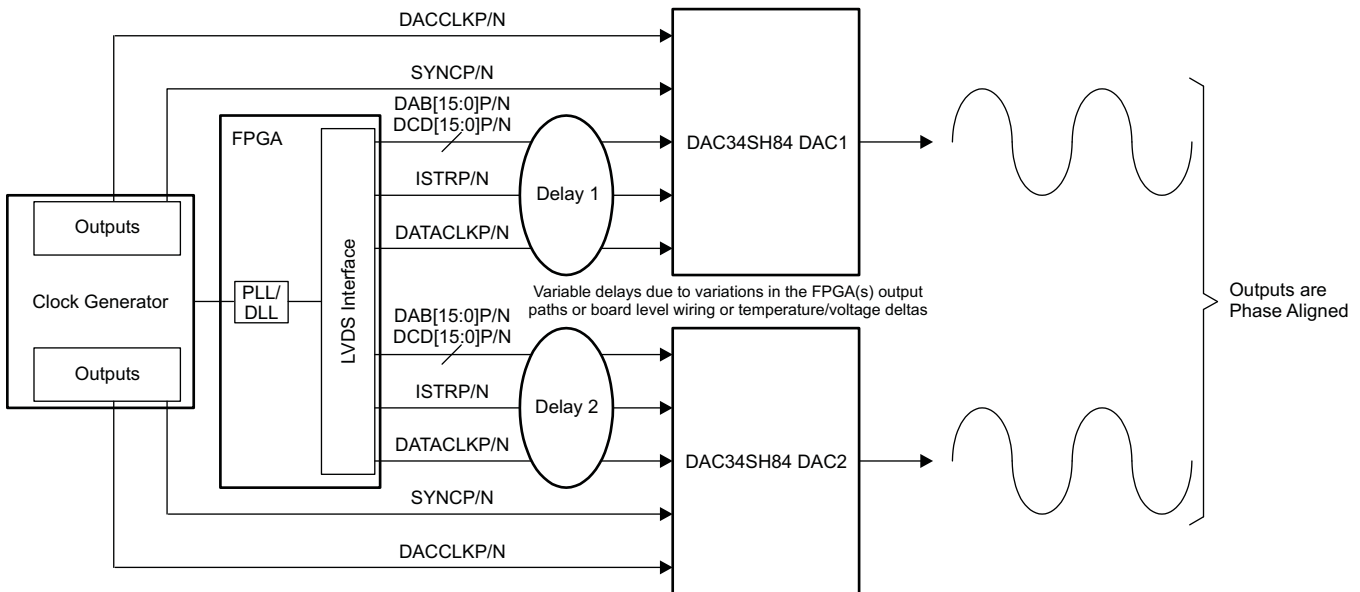

B0455-04

Figure 86. Synchronization System in Dual Sync Sources Mode with PLL Enabled

The following steps are required to ensure the devices are fully synchronized. The procedure assumes all the DAC34SH84 devices have a DACCLK and OSTR signal and must be carried out on each device.

1. Start up the device as described in the power-up sequence. Set the DAC34SH84 in Dual Sync Sources mode and enable SYNC to reset the PLL dividers (set *pll_ndivsync_ena* in register *config24* to 1).
2. Reset the PLL dividers with a rising edge on SYNC.
3. Disable PLL dividers resetting.
4. Sync the clock divider and FIFO pointers.
5. Verify there are no FIFO alarms either through register *config5* or through the ALARM pin.
6. Disable clock divider sync by setting *clkdiv_sync_ena* to 0 in register *config0*.

After these steps all the DAC34SH84 outputs will be synchronized.

7.4.1.3 Multi-Device Operation: Single Sync Source Mode

In Single Sync Source mode, the FIFO write and read pointers are reset from the same sync source, either ISTR or SYNC. Although the FIFO in this mode can still absorb the data delay differences due to variations in the digital source output paths or board level wiring it is impossible to guarantee data will be read from the FIFO of different devices simultaneously thus preventing exact phase alignment.

In Single Sync Source mode the FIFO read pointer reset is handoff between the two clock domains (DATACLK and FIFO OUT CLOCK) by simply re-sampling the write pointer reset. Since the two clocks are asynchronous there is a small but distinct possibility of a meta-stability during the pointer handoff. This meta-stability can cause the outputs of the multiple devices to slip by up to 2 DAC clock cycles.

When the PLL is enabled with Single Sync Source mode, the FIFO read pointer is not synchronized by the OSTR signal. Therefore, there is no restriction on the PLL PFD frequency as described in the previous section.

Device Functional Modes (continued)

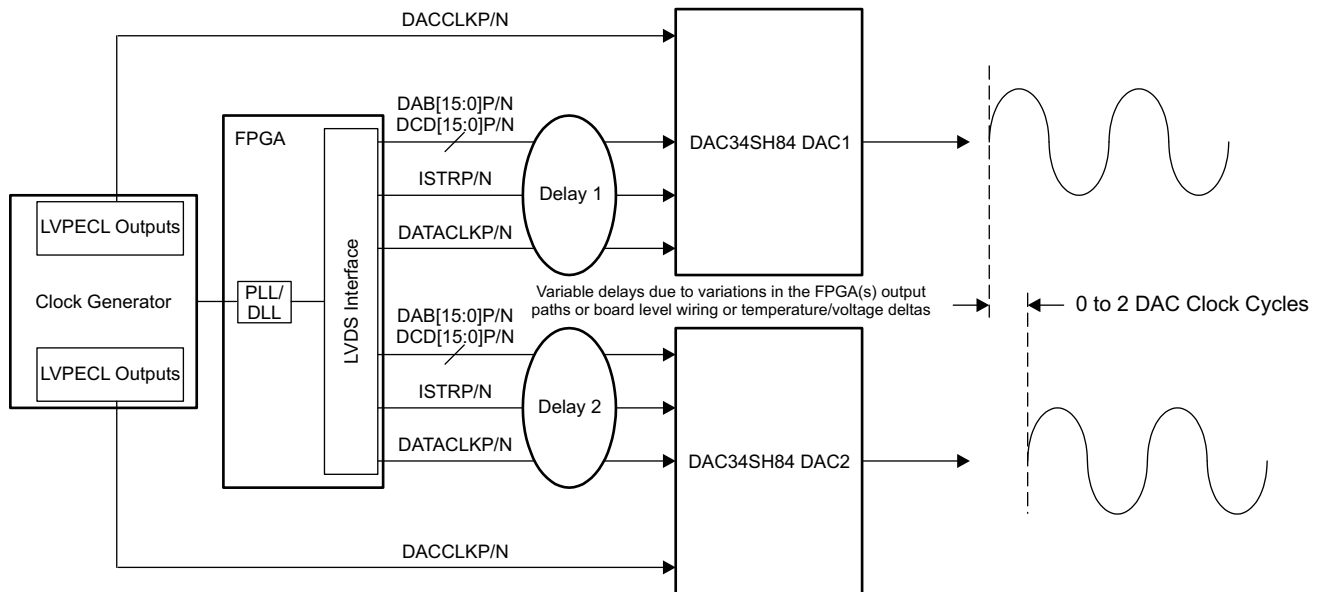

B0456-04

Figure 87. Multi-Device Operation in Single Sync Source Mode

7.5 Programming

7.5.1 Power-Up Sequence

The following startup sequence is recommended to power-up the DAC34SH84:

1. Set TXENA low
2. Supply all 1.35-V voltages (DACVDD, CLKVDD), 1.3-V voltages (DIGVDD, VFUSE), and 3.3-V voltages (AVDD, IOVDD, and PLLAVDD). The 1.2-V and 3.3-V supplies can be powered up simultaneously or in any order. There are no specific requirements on the ramp rate for the supplies.
3. Provide all LVPECL inputs: DACCLKP/N and the optional OSTRP/N. These inputs can also be provided after the SIF register programming.
4. Toggle the RESETB pin for a minimum 25 ns active low pulse width.
5. Program the SIF registers.
6. Program *fuse_sleep* (*config27*, bit<11>) to put the internal fuses to sleep.
7. FIFO configuration needed for synchronization:
 - (a) Program *syncsel_fifoin*(3:0) (*config32*, bit<15:12>) to select the FIFO input pointer sync source.
 - (b) Program *syncsel_fifoout*(3:0) (*config32*, bit<11:8>) to select the FIFO output pointer sync source.
 - (c) Program *syncsel_fifo_input*(1:0) (*config31*, bit<3:2>) to select the FIFO input sync source.
8. Clock divider configuration needed for synchronization:
 - (a) Program *clkdiv_sync_sel* (*config32*, bit<0>) to select the clock divider sync source.
 - (b) Program *clkdiv_sync_ena* (*config0*, bit<2>) to 1 to enable clock divider sync.
 - (c) For multi-DAC synchronization in PLL mode, program *pll_ndivsync_ena* (*config24*, bit<11>) to 1 to synchronize the PLL N-divider.
9. Provide all LVDS inputs (D[15:0]P/N, DCD[15:0]P/N, DATACLKP/N, ISTRP/N, SYNCNP/N and PARITYP/N) simultaneously. Synchronize the FIFO and clock divider by providing the pulse or periodic signals needed.
 - (a) For Single Sync Source Mode where either ISTRP/N or SYNCNP/N is used to sync the FIFO, a single rising edge for FIFO and clock divider sync is recommended. Periodic sync signal is not recommended due to the non-deterministic latency of the sync signal through the clock domain transfer.
 - (b) For Dual Sync Sources Mode, both single pulse or periodic sync signals can be used.
 - (c) For multi-DAC synchronization in PLL mode, the LVDS SYNCNP/N signal is used to sync the PLL N-

Programming (continued)

divider and can be sourced from either the FPGA/ASIC pattern generator or clock distribution circuit as long as the $t_{(\text{SYNC_PLL})}$ setup and hold timing requirement is met with respect to the reference clock source at DACCLKP/N pins. The LVDS SYNCN/P signal can be provided at this point.

10. FIFO and clock divider configurations after all the sync signals have provided the initial sync pulses needed for synchronization:
 - (a) For Single Sync Source Mode where the clock divider sync source is either ISTRP/N or SYNCN/P, clock divider syncing must be disabled after DAC34SH84 initialization and before the data transmission by setting *clkdiv_sync_ena* (*config0*, bit 2) to 0.
 - (b) For Dual Sync Sources Mode, where the clock divider sync source is from the OSTR signal (either from external OSTRP/N or internal PLL N divider output), the clock divider syncing may be enabled at all time.
 - (c) Optionally, to prevent accidental syncing of the FIFO when sending the ISTRP/N or SYNCN/P pulse to other digital blocks such as NCO, QMC, etc, disable FIFO syncing by setting *syncsel_fifoin(3:0)* and *syncsel_fifoout(3:0)* to 0000 after the FIFO input and output pointers are initialized. If the FIFO and sync remain enabled after initialization, the ISTRP/N or SYNCN/P pulse must occur in ways to not disturb the FIFO operation. Refer to the INPUT FIFO section for detail.
 - (d) Disable PLL N-divider syncing by setting *pll_ndivsync_ena* (*config24*, bit<11>) to 0.
11. Enable transmit of data by asserting the TXENA pin or set *sif_txenable* to 1.
12. At any time, if any of the clocks (that is, DATACLK or DACCLK) is lost or a FIFO collision alarm is detected, a complete resynchronization of the DAC is necessary. Set TXENABLE low and repeat steps 7 through 11. Program the FIFO configuration and clock divider configuration per steps 7 and 8 appropriately to accept the new sync pulse or pulses for the synchronization.

7.5.2 Example Start-Up Routine

7.5.2.1 Device Configuration

$f_{\text{DATA}} = 737.28 \text{ MSPS}$
 Interpolation = 2×
 Input data = baseband data
 $f_{\text{OUT}} = 122.88 \text{ MHz}$
 PLL = Enabled
 Full Mixer = Enabled
 NCO = Enabled
 Dual Sync Sources Mode

7.5.2.2 PLL Configuration

$f_{\text{REFCLK}} = 737.28 \text{ MHz}$ at the DACCLKP/N LVPECL pins
 $f_{\text{DACCLK}} = f_{\text{DATA}} \times \text{Interpolation} = 1474.56 \text{ MHz}$
 $f_{\text{VCO}} = 2 \times f_{\text{DACCLK}} = 2949.12 \text{ MHz}$ (keep f_{VCO} between 2.7 GHz and 3.3 GHz)
 $\text{PFD} = f_{\text{OSTR}} = 46.08 \text{ MHz}$
 $N = 16, M = 32, P = 2$, single charge pump
 $\text{pll_vco}(5:0) = 01\ 1100\ (28)$

7.5.2.3 NCO Configuration

$f_{\text{NCO}} = 122.88 \text{ MHz}$
 $f_{\text{NCO_CLK}} = 1474.56 \text{ MHz}$

Programming (continued)

$$\text{freq} = f_{\text{NCO}} \times 2^{32} / 1228.8 = 357,913,941 = 0x1555\ 5555$$

$$\text{phaseaddAB}(31:0) \text{ and/or } \text{phaseaddCD}(31:0) = 0x1555\ 5555$$

NCO SYNC = rising edge of LVDS SYNC

7.5.2.4 Example Start-Up Sequence
Table 10. Example Start-Up Sequence Description

STEP	READ/WRITE	ADDRESS	VALUE	DESCRIPTION
1	N/A	N/A	N/A	Set TXENA low
2	N/A	N/A	N/A	Power up the device
3	N/A	N/A	N/A	Apply LVPECL DACCLKP/N for PLL reference clock
4	N/A	N/A	N/A	Toggle RESETB pin
5	Write	0x00	0xF19F	QMC offset and correction enabled, 2x int, FIFO enabled, Alarm enabled, clock divider sync enabled, inverse sinc filter enabled.
6	Write	0x01	0x040E	Single parity enabled, FIFO alarms enabled (2 away, 1 away, and collision).
7	Write	0x02	0x7052	Output shut-off when DACCLK gone, DATACLK gone, and FIFO collision. Mixer block with NCO enabled, twos complement.
8	Write	0x03	0xA000	Output current set to 20 mA _{FS} with internal reference and 1.28-kΩ R _{BIAS} resistor.
9	Write	0x07	0xD8FF	Un-mask FIFO collision, DACCLK-gone, and DATACLK-gone alarms to the Alarm output.
10	Write	0x08	N/A	Program the desired channel A QMC offset value. (Causes auto-sync for QMC AB-channels offset block)
11	Write	0x09	N/A	Program the desired FIFO offset value and channel B QMC offset value.
12	Write	0x0A	N/A	Program the desired channel C QMC offset value. (Causes auto-sync for QMC CD-channels offset block)
13	Write	0x0B	N/A	Program the desired channel D QMC offset value.
14	Write	0x0C	N/A	Program the desired channel A QMC gain value.
15	Write	0x0D	N/A	Coarse mixer mode not used. Program the desired channel B QMC gain value.
16	Write	0x0E	N/A	Program the desired channel B QMC gain value.
17	Write	0x0F	N/A	Program the desired channel C QMC gain value.
18	Write	0x10	N/A	Program the desired channel AB QMC phase value. (Causes Auto-Sync QMC AB-Channels Correction Block)
19	Write	0x11	N/A	Program the desired channel CD QMC phase value. (Causes Auto-Sync for the QMC CD-Channels Correction Block)
20	Write	0x12	N/A	Program the desired channel AB NCO phase offset value. (Causes Auto-Sync for Channel AB NCO Mixer)
21	Write	0x13	N/A	Program the desired channel CD NCO phase offset value. (Causes Auto-Sync for Channel CD NCO Mixer)
22	Write	0x14	0x5555	Program the desired channel AB NCO frequency value
23	Write	0x15	0x1555	Program the desired channel AB NCO frequency value
24	Write	0x16	0x5555	Program the desired channel CD NCO frequency value
25	Write	0x17	0x1555	Program the desired channel CD NCO frequency value
26	Write	0x18	0x2C50	PLL enabled, PLL N-dividers sync enabled, single charge pump, prescaler = 2.
27	Write	0x19	0x20F4	M = 32, N = 16, PLL VCO bias tune = 01
28	Write	0x1A	0x7010	PLL VCO coarse tune = 28
29	Write	0x1B	0x0800	Internal reference
30	Write	0x1E	0x9999	QMC offset AB, QMC offset CD, QMC correction AB, and QMC correction CD can be synced by <code>sif_sync</code> or auto-sync from register write

Programming (continued)
Table 10. Example Start-Up Sequence Description (continued)

STEP	READ/WRITE	ADDRESS	VALUE	DESCRIPTION
31	Write	0x1F	0x4440	Mixer AB and CD values synced by SYNC/N. NCO accumulator synced by SYNC/N.
32	Write	0x20	0x2400	FIFO Input Pointer Sync Source = ISTR FIFO Output Pointer Sync Source = OSTR (from PLL N-divider output) Clock Divider Sync Source = OSTR
33	N/A	N/A	N/A	Provide all the LVDS DATA and DATACLK Provide rising edge ISTRP/N and rising edge SYNC/N to sync the FIFO input pointer and PLL N-dividers.
34	Read	0x18	N/A	Read back pll_lfvolt(2:0). If the value is not optimal, adjust pll_vco(5:0) in 0x1A.
35	Write	0x05	0x0000	Clear all alarms in 0x05.
36	Read	0x05	N/A	Read back all alarms in 0x05. Check for PLL lock, FIFO collision, DACCLK-gone, DATACLK-gone, ... Fix the error appropriately. Repeat step 34 and 35 as necessary.
37	Write	0x1F	0x4442	Sync all the QMC blocks using sif_sync. These blocks can also be synced via auto-sync through appropriate register writes.
38	Write	0x00	0xF19B	Disable clock divider sync.
39	Write	0x1F	0x4448	Set sif_sync to 0 for the next sif_sync event.
40	Write	0x20	0x0000	Disable FIFO input and output pointer sync.
41	Write	0x18	0x2450	Disable PLL N-dividers sync.
42	N/A	N/A	N/A	Set TXENA high. Enable data transmission.

7.6 Register Map

Table 11. Register Map⁽¹⁾

Name	Address	Default	(MSB) Bit 15	Bit 14	Bit 13	Bit 12	Bit 11	Bit 10	Bit 9	Bit 8	Bit 7	Bit 6	Bit 5	Bit 4	Bit 3	Bit 2	Bit 1	(LSB) Bit 0		
config0	0x00	0x049C	qmc_offsetAB_ena	qmc_offsetCD_ena	qmc_corrAB_ena	qmc_corrCD_ena	interp(3:0)			fifo_ena	reserved	reserved	alarm_out_ena	alarm_out_pol	clkdiv_sync_ena	invsincAB_ena	invsincCD_ena			
config1	0x01	0x040E	iotest_ena	reserved	reserved	64cnt_ena	oddeven_parity	parity_ena	single_dual_parity	rev_interface	dacA_complement	dacB_complement	dacC_complement	dacD_complement	alarm_2away_ena	alarm_1away_ena	alarm_collision_ena	reserved		
config2	0x02	0x7000	reserved	dacclockgone_ena	dataackgone_ena	collisiongone_ena	reserved	reserved	reserved	reserved	sif4_ena	mixer_ena	mixer_gain	nco_ena	revbus	reserved	twos	reserved		
config3	0x03	0xF000	coarse_dac(3:0)			reserved			reserved									sif_txenable		
config4	0x04	NA	iotest_results(15:0)																	
config5	0x05	NA	alarm_from_zerock	reserved	alarms_from_fifo(2:0)			alarm_dacclk_gone	alarm_dataclk_gone	alarm_output_gone	alarm_from_iotest	reserved	alarm_from_pll	alarm_Aparity	alarm_Bparity	alarm_Cparity	alarm_Dparity	reserved		
config6	0x06	NA	tempdata(7:0)							reserved									reserved	reserved
config7	0x07	0xFFFF	alarms_mask(15:0)																	
config8	0x08	0x0000	reserved	reserved	reserved	qmc_offsetA(12:0)														
config9	0x09	0x8000	fifo_offset(2:0)			qmc_offsetB(12:0)														
config10	0x0A	0x0000	reserved	reserved	reserved	qmc_offsetC(12:0)														
config11	0x0B	0x0000	reserved	reserved	reserved	qmc_offsetD(12:0)														
config12	0x0C	0x0400	reserved	reserved	reserved	reserved	reserved	qmc_gainA(10:0)												
config13	0x0D	0x0400	cmix(3:0)				reserved	qmc_gainB(10:0)												
config14	0x0E	0x0400	reserved	reserved	reserved	reserved	reserved	qmc_gainC(10:0)												
config15	0x0F	0x0400	output_delayAB(1:0)		output_delayCD(1:0)		reserved	qmc_gainD(10:0)												
config16	0x10	0x0000	reserved	reserved	reserved	reserved	qmc_phaseAB(11:0)													
config17	0x11	0x0000	reserved	reserved	reserved	reserved	qmc_phaseCD(11:0)													
config18	0x12	0x0000	phase_offsetAB(15:0)																	
config19	0x13	0x0000	phase_offsetCD(15:0)																	
config20	0x14	0x0000	phase_addAB(15:0)																	
config21	0x15	0x0000	phase_addAB(31:16)																	
config22	0x16	0x0000	phase_addCD(15:0)																	
config23	0x17	0x0000	phase_addCD(31:16)																	
config24	0x18	NA	reserved			pll_reset	pll_ndivsync_ena	pll_ena	reserved			pll_cp(1:0)		pll_p(2:0)		pll_lfvolt(2:0)				
config25	0x19	0x0440	pll_m(7:0)							pll_n(3:0)			pll_vcotune(1:0)			reserved				
config26	0x1A	0x0020	pll_vco(5:0)						reserved	reserved	bias_sleep	tsense_sleep	pll_sleep	clkrecv_sleep	sleepA	sleepB	sleepC	sleepD		
config27	0x1B	0x0000	extref_ena	reserved	reserved	reserved	fuse_sleep	reserved	reserved	reserved	reserved	reserved	reserved							
config28	0x1C	0x0000	reserved									reserved								

(1) Unless otherwise noted, all reserved registers should be programmed to default values.

DAC34SH84

SLAS808E – FEBRUARY 2012 – REVISED SEPTEMBER 2015

www.ti.com
Register Map (continued)
Table 11. Register Map (continued)

Name	Address	Default	(MSB) Bit 15	Bit 14	Bit 13	Bit 12	Bit 11	Bit 10	Bit 9	Bit 8	Bit 7	Bit 6	Bit 5	Bit 4	Bit 3	Bit 2	Bit 1	(LSB) Bit 0	
config29	0x1D	0x0000	reserved								reserved								
config30	0x1E	0x1111	syncsel_qmoffsetAB(3:0)				syncsel_qmoffsetCD(3:0)				syncsel_qmcorrAB(3:0)				syncsel_qmcorrCD(3:0)				
config31	0x1F	0x1140	syncsel_mixerAB(3:0)				syncsel_mixerCD(3:0)				syncsel_nco(3:0)				syncsel_fifo_input		sif_sync	reserved	
config32	0x20	0x2400	syncsel_fifoin(3:0)				syncsel_fifoout(3:0)				reserved								clkdiv_sync_sel
config33	0x21	0x0000	reserved																
config34	0x22	0x1B1B	pathA_in_set(1:0)		pathB_in_set(1:0)		pathC_in_set(1:0)		pathD_in_set(1:0)		DACA_out_set(1:0)		DACB_out_set(1:0)		DACC_out_set(1:0)		DACD_out_set(1:0)		
config35	0x23	0xFFFF	sleep_cntl(15:0)																
config36	0x24	0x0000	datadly(2:0)			clkdly(2:0)			reserved										
config37	0x25	0x7A7A	iotest_pattern0																
config38	0x26	0xB6B6	iotest_pattern1																
config39	0x27	0xEAEA	iotest_pattern2																
config40	0x28	0x4545	iotest_pattern3																
config41	0x29	0x1A1A	iotest_pattern4																
config42	0x2A	0x1616	iotest_pattern5																
config43	0x2B	0xAAAA	iotest_pattern6																
config44	0x2C	0xC6C6	iotest_pattern7																
config45	0x2D	0x0004	reserved	ostrtodig_sel	ramp_ena	reserved											sifdac_ena		
config46	0x2E	0x0000	grp_delayA(7:0)								grp_delayB(7:0)								
config47	0x2F	0x0000	grp_delayC(7:0)								grp_delayD(7:0)								
config48	0x30	0x0000	sifdac(15:0)																
version	0x7F	0x5428	reserved						reserved	reserved		die_id_34SH84(1:0)		deviceid(1:0)		versionid(2:0)			

7.6.1 Register Descriptions
Table 12. Register Name: config0 – Address: 0x00, Default: 0x049C

Register Name	Address	Bit	Name	Function	Default Value												
config0	0x00	15	qmc_offsetAB_ena	When set, the digital quadrature modulator correction (QMC) offset correction for the AB data path is enabled.	0												
		14	qmc_offsetCD_ena	When set, the digital QMC offset correction for the CD data path is enabled.	0												
		13	qmc_corrAB_ena	When set, the QMC phase and gain correction circuitry for the AB data path is enabled.	0												
		12	qmc_corrCD_ena	When set, the QMC phase and gain correction circuitry for the CD data path is enabled.	0												
		11:8	interp(3:0)	These bits define the interpolation factor.	0100												
				<table border="1"> <thead> <tr> <th>interp</th> <th>Interpolation Factor</th> </tr> </thead> <tbody> <tr> <td>0000</td> <td>1x</td> </tr> <tr> <td>0001</td> <td>2x</td> </tr> <tr> <td>0010</td> <td>4x</td> </tr> <tr> <td>0100</td> <td>8x</td> </tr> <tr> <td>1000</td> <td>16x</td> </tr> </tbody> </table>		interp	Interpolation Factor	0000	1x	0001	2x	0010	4x	0100	8x	1000	16x
		interp	Interpolation Factor														
		0000	1x														
		0001	2x														
		0010	4x														
		0100	8x														
		1000	16x														
		7	fifo_ena	When set, the FIFO is enabled. When the FIFO is disabled. DACCLKP/N and DATACLKP/N must be aligned (not recommended).	1												
6	Reserved	Reserved for factory use	0														
5	Reserved	Reserved for factory use	0														
4	alarm_out_ena	When set, the ALARM pin becomes an output. When cleared, the ALARM pin is in the high-impedance state.	1														
3	alarm_out_pol	This bit changes the polarity of the ALARM signal. 0: Negative logic 1: Positive logic	1														
2	clkdiv_sync_ena	When set, enables the syncing of the clock divider and the FIFO output pointer using the sync source selected by register <i>config32</i> . The internal divided-down clocks are phase-aligned after syncing. See the Power-Up Sequence section for more detail.	1														
1	invsincAB_ena	When set, the inverse sinc filter for the AB data path is enabled.	0														
0	invsincCD_ena	When set, the inverse sinc filter for the CD data path is enabled.	0														

Table 13. Register Name: config1 – Address: 0x01, Default: 0x040E

Register Name	Address	Bit	Name	Function	Default Value
config1	0x01	15	iotest_ena	When set, enables the data pattern checker test. The outputs are deactivated regardless of the state of TXENA and sif_txenable.	0
		14	Reserved	Reserved for factory use	0
		13	Reserved	Reserved for factory use	0
		12	64cnt_ena	When set, enables resetting of the alarms after 64 good samples with the goal of removing unnecessary errors. For instance, when checking setup or hold through the pattern checker test, there may initially be errors. Setting this bit removes the need for a SIF write to clear the alarm register.	0
		11	oddeven_parity	Selects between odd and even parity check 0: Even parity 1: Odd parity	0
		10	parity_ena	When set, enables parity checking of each input word using the 1 PARITYP/N parity input. It should match the oddeven_parity register setting.	1
		9	single_dual_parity	When set, enables dual parity checking; otherwise, single parity checking. The parity bit should match the oddeven_parity register setting. <i>parity_ena</i> must be set for dual parity to function.	0
		8	rev_interface	When set, the PARITY, SYNC, and ISTR inputs are rotated to allow complete reversal of the data interface when setting the <i>rev_interface</i> bit. When <i>rev_interface</i> = 1, the following changes occurs 1. SYNC/N becomes ISTRP/N. 2. PARITYP/N becomes SYNC/N. 3. ISTRP/N becomes PARITYP/N.	0
		7	dacA_complement	When set, the DACA output is complemented. This allows effectively changing the + and – designations of the LVDS data lines.	0
		6	dacB_complement	When set, the DACB output is complemented. This allows effectively changing the + and – designations of the LVDS data lines.	0
		5	dacC_complement	When set, the DACC output is complemented. This allows effectively changing the + and – designations of the LVDS data lines.	0
		4	dacD_complement	When set, the DACD output is complemented. This allows effectively changing the + and – designations of the LVDS data lines.	0
		3	alarm_2away_ena	When set, the alarm from the FIFO indicating the write and read pointers being 2 away is enabled.	1
		2	alarm_1away_ena	When set, the alarm from the FIFO indicating the write and read pointers being 1 away is enabled.	1
1	alarm_collision_ena	When set, the alarm from the FIFO indicating a collision between the write and read pointers is enabled.	1		
0	Reserved	Reserved for factory use	0		

Table 14. Register Name: config2 – Address: 0x02, Default: 0x7000

Register Name	Address	Bit	Name	Function	Default Value
config2	0x02	15	Reserved	Reserved for factory use	0
		14	dacclkgone_ena	When set, the DACCLK-gone signal from the clock monitor circuit can be used to shut off the DAC outputs. The corresponding alarms, <i>alarm_dacclk_gone</i> and <i>alarm_output_gone</i> , must not be masked (for example, <i>config7</i> , bit <10> and bit <8> must set to 0).	1
		13	dataclkgone_ena	When set, the DATACLK-gone signal from the clock monitor circuit can be used to shut off the DAC outputs. The corresponding alarms, <i>alarm_dataclk_gone</i> and <i>alarm_output_gone</i> , must not be masked (for example, <i>config7</i> , bit <9> and bit <8> must set to 0).	1
		12	collisiongone_ena	When set, the FIFO collision alarms can be used to shut off the DAC outputs. The corresponding alarms, <i>alarm_fifo_collision</i> and <i>alarm_output_gone</i> , must not be masked (for example, <i>config7</i> , bit <13> and bit <8> must set to 0).	1
		11	Reserved	Reserved for factory use	0
		10	Reserved	Reserved for factory use	0
		9	Reserved	Reserved for factory use	0
		8	Reserved	Reserved for factory use	0
		7	sif4_ena	When set, the serial interface (SIF) is a 4-bit interface; otherwise, it is a 3-bit interface.	0
		6	mixer_ena	When set, the mixer block is enabled.	0
		5	mixer_gain	When set, a 6-dB gain is added to the mixer output.	0
		4	nco_ena	When set, the NCO is enabled. This is not required for coarse mixing.	0
		3	revbus	When set, the input bits for the data bus are reversed. MSB becomes LSB.	0
		2	Reserved	Reserved for factory use	0
		1	twos	When set, the input data format is expected to be 2s-complement. When cleared, the input is expected to be offset-binary.	0
0	Reserved	Reserved for factory use	0		

Table 15. Register Name: config3 – Address: 0x03, Default: 0xF000

Register Name	Address	Bit	Name	Function	Default Value
config3	0x03	15:12	coarse_dac(3:0)	Scales the output current in 16 equal steps. $I_{FS} = \frac{V_{EXTIO}}{R_{BIAS}} \times 2 \times (\text{coarse_dac} + 1)$	1111
		11:8	Reserved	Reserved for factory use	0000
		7:1	Reserved	Reserved for factory use	0000 000
		0	sif_txenable	When set, the internal value of TXENABLE is set to 1. To enable analog output data transmission, set <i>sif_txenable</i> to 1 or pull the CMOS TXENA pin (N9) to high. To disable analog output, set <i>sif_txenable</i> to 0 and pull the CMOS TXENA pin (N9) to low.	0

Table 16. Register Name: config4 – Address: 0x04, Default: No RESET Value (Write to Clear)

Register Name	Address	Bit	Name	Function	Default Value
config4	0x04	15:0	iotest_results(15:0)	Bits in <i>iotest_results</i> with a logic value of 1 tell which bit in either DAB[15:0] bus or DCD[15:0] bus failed during the pattern checker test. <i>iotest_results</i> (15:8) correspond to the data bits on both DAB[15:8] and DCD[15:8]. <i>iotest_results</i> (7:0) correspond to the data bits on both DAB[7:0] and DCD[7:0].	No RESET value

Table 17. Register Name: config5 – Address: 0x05, Default: Setup and Power-Up Conditions Dependent (Write to Clear)

Register Name	Address	Bit	Name	Function	Default Value
config5	0x05	15	alarm_from_zerockh	This alarm indicates the 8-bit FIFO write pointer address has an all-zeros pattern. Due to the pointer address being a shift register, this is not a valid address and causes the write pointer to be stuck until the next sync. This error is typically caused by a timing error or improper power start-up sequence. If this alarm is asserted, resynchronization of the FIFO is necessary. See the Power-Up Sequence section for more detail.	NA
		14	Reserved	Reserved for factory use	NA
		13:11	alarms_from_fifo(2:0)	Alarm indicating FIFO pointer collisions and nearness: 000: All fine 001: Pointers are 2 away. 01x: Pointers are 1 away. 1xx: FIFO pointer collision If the FIFO pointer collision alarm is set when <i>collisiogone_ena</i> is enabled, the FIFO must be re-synchronized and the bits must be cleared to resume normal operation.	NA
		10	alarm_dacclk_gone	Alarm indicating the DACCLK has been stopped. If the bit is set when <i>dacclkgone_ena</i> is enabled, DACCLK must resume and the bit must be cleared to resume normal operation.	NA
		9	alarm_dataclk_gone	Alarm indicating the DATACLK has been stopped. If the bit is set when <i>dataclkgone_ena</i> is enabled, DATACLK must resume and the bit must be cleared to resume normal operation.	NA
		8	alarm_output_gone	Alarm indicating either <i>alarm_dacclk_gone</i> , <i>alarm_dataclk_gone</i> , or <i>alarm_fifo_collision</i> are asserted. It controls the output. When high, it outputs 0x8000 for each output connected to the DAC. If the bit is set when <i>dacclkgone_ena</i> , <i>dataclkgone_ena</i> , or <i>collisiogone_ena</i> are enabled, then the corresponding errors must be fixed and the bits must be cleared to resume normal operation.	NA
		7	alarm_from_iotest	Alarm indicating the input data pattern does not match the pattern in the <i>iotest_pattern</i> registers. When the data pattern checker mode is enabled, this alarm in register <i>config5</i> , bit7 is the only valid alarm. Other alarms in register <i>config5</i> are not valid and can be disregarded.	NA
		6	Reserved	Reserved for factory use	NA
		5	alarm_from_pll	Alarm indicating the PLL has lost lock. For version ID 001, <i>alarm_from_PLL</i> may not indicate the correct status of the PLL. See <i>pll_lfvolt(2:0)</i> in register <i>config24</i> for proper PLL lock indication.	NA
		4	alarm_Aparity	In dual-parity mode, an alarm indicating a parity error on the A word. In single-parity mode, an alarm on the 32-bit data captured on the rising edge of DATACLKP/N.	NA
		3	alarm_Bparity	In dual-parity mode, an alarm indicating a parity error on the B word. In single-parity mode, an alarm on the 32-bit data captured on the falling edge of DATACLKP/N.	NA
		2	alarm_Cparity	In dual-parity mode, an alarm indicating a parity error on the C word.	NA
		1	alarm_Dparity	In dual-parity mode, an alarm indicating a parity error on the D word.	NA
		0	Reserved	Reserved for factory use	NA

Table 18. Register Name: config6 – Address: 0x06, Default: No RESET Value (Read Only)

Register Name	Address	Bit	Name	Function	Default Value
config6	0x06	15:8	tempdata(7:0)	This is the output from the chip temperature sensor. The value of this register in 2s-complement format represents the temperature in degrees Celsius. This register must be read with a minimum SCLK period of 1 μs.	No RESET Value
		7:2	Reserved	Reserved for factory use	0000 00
		1	Reserved	Reserved for factory use	0
		0	Reserved	Reserved for factory use	0

Table 19. Register Name: config7 – Address: 0x07, Default: 0xFFFF

Register Name	Address	Bit	Name	Function	Default Value			
config7	0x07	15:0	alarms_mask(15:0)	These bits control the masking of the alarms. (0 = not masked, 1 = masked)		0xFFFF		
				alarm_mask			Alarm That Is Masked	
				15	alarm_from_zerockh			
				14	Not used			
				13	alarm_fifo_collision			
				12	alarm_fifo_1away			
				11	alarm_fifo_2away			
				10	alarm_dacclk_gone			
				9	alarm_dataclk_gone			
				8	alarm_output_gone			
				7	alarm_from_iotest			
				6	Not used			
				5	alarm_from_pll			
				4	alarm_Aparity			
				3	alarm_Bparity			
				2	alarm_Cparity			
1	alarm_Dparity							
0	Not used							

Table 20. Register Name: config8 – Address: 0x08, Default: 0x0000 (Causes Auto-Sync)

Register Name	Address	Bit	Name	Function	Default Value
config8	0x08	15	Reserved	Reserved for factory use	0
		14	Reserved	Reserved for factory use	0
		13	Reserved	Reserved for factory use	0
		12:0	qmc_offsetA(12:0)	DACA offset correction. The offset is measured in DAC LSBs. If enabled in config30, writing to this register causes an auto-sync to be generated. This loads the values of the QMC offset registers (config8–config9) into the offset block at the same time. When updating the offset values for the AB channel, config8 should be written last. Programming config9 does not affect the offset setting.	All zeros

Table 21. Register Name: config9 – Address: 0x09, Default: 0x8000

Register Name	Address	Bit	Name	Function	Default Value
config9	0x09	15:13	fifo_offset(2:0)	When the sync to the FIFO occurs, this is the value loaded into the FIFO read pointer. With this value, the initial difference between write and read pointers can be controlled. This may be helpful in syncing multiple chips or controlling the delay through the device.	100
		12:0	qmc_offsetB(12:0)	DACB offset correction. The offset is measured in DAC LSBs.	All zeros

Table 22. Register Name: config10 – Address: 0x0A, Default: 0x0000 (Causes Auto-Sync)

Register Name	Address	Bit	Name	Function	Default Value
config10	0x0A	15	Reserved	Reserved for factory use	0
		14	Reserved	Reserved for factory use	0
		13	Reserved	Reserved for factory use	0
		12:0	qmc_offsetC(12:0)	DACC offset correction. The offset is measured in DAC LSBs. If enabled in config30 writing to this register causes an auto-sync to be generated. This loads the values of the CD-channel QMC offset registers (config10–config11) into the offset block at the same time. When updating the offset values for the CD-channel config10 should be written last. Programming config11 does not affect the offset setting.	All zeros

Table 23. Register name: config11 – Address: 0x0B, Default: 0x0000

Register Name	Address	Bit	Name	Function	Default Value
config11	0x0B	15	Reserved	Reserved for factory use	0
		14	Reserved	Reserved for factory use	0
		13	Reserved	Reserved for factory use	0
		12:0	qmc_offsetD(12:0)	DACD offset correction. The offset is measured in DAC LSBs.	All zeros

Table 24. Register Name: config12 – Address: 0x0C, Default: 0x0400

Register Name	Address	Bit	Name	Function	Default Value
config12	0x0C	15	Reserved	Reserved for factory use	0
		14	Reserved	Reserved for factory use	0
		13	Reserved	Reserved for factory use	0
		12	Reserved	Reserved for factory use	0
		11	Reserved	Reserved for factory use	0
		10:0	qmc_gainA(10:0)	QMC gain for DACA. The full 11-bit <i>qmc_gainA(10:0)</i> word is formatted as UNSIGNED with a range of 0 to 1.9990. The implied decimal point for the multiplication is between bit 9 and bit 10.	100 0000 0000

Table 25. Register Name: config13 – Address: 0x0D, Default: 0x0400

Register Name	Address	Bit	Name	Function	Default Value
config13	0x0D	15:12	cmix_mode(3:0)	Sets the mixing function of the coarse mixer. Bit 15: $f_s / 8$ mixer Bit 14: $f_s / 4$ mixer Bit 13: $f_s / 2$ mixer Bit 12: $-f_s / 4$ mixer The various mixers can be combined together to obtain a $\pm n \times f_s / 8$ total mixing factor.	0000
		11	Reserved	Reserved for factory use	0
		10:0	qmc_gainB(10:0)	QMC gain for DACB. The full 11-bit <i>qmc_gainB(10:0)</i> word is formatted as UNSIGNED with a range of 0 to 1.9990. The implied decimal point for the multiplication is between bit 9 and bit 10.	100 0000 0000

Table 26. Register Name: config14 – Address: 0x0E, Default: 0x0400

Register Name	Address	Bit	Name	Function	Default Value
config14	0x0E	15	Reserved	Reserved for factory use	0
		14	Reserved	Reserved for factory use	0
		13	Reserved	Reserved for factory use	0
		12	Reserved	Reserved for factory use	0
		11	Reserved	Reserved for factory use	0
		10:0	qmc_gainC(10:0)	QMC gain for DACC. The full 11-bit <i>qmc_gainC(10:0)</i> word is formatted as UNSIGNED with a range of 0 to 1.9990. The implied decimal point for the multiplication is between bit 9 and bit 10.	100 0000 0000

Table 27. Register Name: config15 – Address: 0x0F, Default: 0x0400

Register Name	Address	Bit	Name	Function	Default Value
config15	0x0F	15:14	output_delayAB(1:0)	Delays the AB data path outputs from 0 to 3 DAC clock cycles	00
		13:12	output_delayCD(1:0)	Delays the CD data path outputs from 0 to 3 DAC clock cycles	00
		11	Reserved	Reserved for factory use	0
		10:0	qmc_gainD(10:0)	QMC gain for DACD. The full 11-bit <i>qmc_gainD(10:0)</i> word is formatted as UNSIGNED with a range of 0 to 1.9990. The implied decimal point for the multiplication is between bit 9 and bit 10.	100 0000 0000

Table 28. Register Name: config16 – Address: 0x10, Default: 0x0000 (Causes Auto-Sync)

Register Name	Address	Bit	Name	Function	Default Value
config16	0x10	15	Reserved	Reserved for factory use	0
		14	Reserved	Reserved for factory use	0
		13	Reserved	Reserved for factory use	0
		12	Reserved	Reserved for factory use	0
		11:0	qmc_phaseAB(11:0)	QMC correction phase for the AB data path. The 12-bit qmc_phaseAB(11:0) word is formatted as 2s-complement and scaled to occupy a range of –0.5 to 0.49975 and a default phase correction of 0.00. To accomplish QMC phase correction, this value is multiplied by the current B sample, then summed into the A sample. If enabled in config30, writing to this register causes an auto-sync to be generated. This loads the values of the QMC offset registers (config12, config13, and config16) into the QMC block at the same time. When updating the QMC values for the AB channel, config16 should be written last. Programming config12 and config13 does not affect the QMC settings.	All zeros

Table 29. Register Name: config17 – Address: 0x11, Default: 0x0000 (Causes Auto-Sync)

Register Name	Address	Bit	Name	Function	Default Value
config17	0x11	15	Reserved	Reserved for factory use	0
		14	Reserved	Reserved for factory use	0
		13	Reserved	Reserved for factory use	0
		12	Reserved	Reserved for factory use	0
		11:0	qmc_phaseCD(11:0)	QMC correction phase for the CD data path. The 12-bit qmc_gainCD(11:0) word is formatted as 2s-complement and scaled to occupy a range of –0.5 to 0.49975 and a default phase correction of 0.00. To accomplish QMC phase correction, this value is multiplied by the current D sample, then summed into the C sample. If enabled in config30, writing to this register causes an auto-sync to be generated. This loads the values of the CD-channel QMC block registers (config14, config15, and config17) into the QMC block at the same time. When updating the QMC values for the CD-channel, config17 should be written last. Programming config14 and config15 does not affect the QMC settings.	All zeros

Table 30. Register Name: config18 – Address: 0x12, Default: 0x0000 (Causes Auto-Sync)

Register Name	Address	Bit	Name	Function	Default Value
config18	0x12	15:0	phase_offsetAB(15:0)	Phase offset added to the AB data path NCO accumulator before the generation of the SIN and COS values. The phase offset is added to the upper 16 bits of the NCO accumulator results, and these 16 bits are used in the sin and cos lookup tables. If enabled in config31, writing to this register causes an auto-sync to be generated. This loads the values of the fine mixer block registers (config18, config20, and config21) at the same time. When updating the mixer values, config18 should be written last. Programming config20 and config21 does not affect the mixer settings.	0x0000

Table 31. Register Name: config19 – Address: 0x13, Default: 0x0000 (Causes Auto-Sync)

Register Name	Address	Bit	Name	Function	Default Value
config19	0x13	15:0	phase_offsetCD(15:0)	Phase offset added to the CD data path NCO accumulator before the generation of the SIN and COS values. The phase offset is added to the upper 16 bits of the NCO accumulator results, and these 16 bits are used in the sin and cos lookup tables. If enabled in config31, writing to this register causes an auto-sync to be generated. This loads the values of the CD-channel fine mixer block registers (config19, config22, and config23) at the same time. When updating the mixer values for the CD-channel, config19 should be written last. Programming config22 and config23 does not affect the mixer settings.	0x0000

Table 32. Register Name: config20 – Address: 0x14, Default: 0x0000

Register Name	Address	Bit	Name	Function	Default Value
config20	0x14	15:0	phase_addAB(15:0)	The phase_addAB(15:0) value is used to determine the NCO frequency. The 2s-complement formatted value can be positive or negative. Each LSB represents an $f_s / (2^{32})$ frequency step.	0x0000

Table 33. Register Name: config21 – Address: 0x15, Default: 0x0000

Register Name	Address	Bit	Name	Function	Default Value
config21	0x15	15:0	phase_addAB(31:16)	See <i>config20</i> .	0x0000

Table 34. Register Name: config22 – Address: 0x16, Default: 0x0000

Register Name	Address	Bit	Name	Function	Default Value
config22	0x16	15:0	phase_addCD(15:0)	The <i>phase_addCD(15:0)</i> value is used to determine the NCO frequency. The 2s-complement formatted value can be positive or negative. Each LSB represents an $f_s / (2^{32})$ frequency step.	0x0000

Table 35. Register Name: config23 – Address: 0x17, Default: 0x0000

Register Name	Address	Bit	Name	Function	Default Value
config23	0x17	15:0	phase_addCD(31:16)	See <i>config22</i> above.	0x0000

Table 36. Register Name: config24 – Address: 0x18, Default: NA

Register Name	Address	Bit	Name	Function	Default Value
config24	0x18	15:13	Reserved	Reserved for factory use	001
		12	pll_reset	When set, the PLL loop filter (LPF) is pulled down to 0 V. Toggle from 1 to 0 to restart the PLL if an overspeed lockup occurs. Overspeed can happen when the process is fast, the supplies are higher than nominal, ..., resulting in the feedback dividers missing a clock.	0
		11	pll_ndivsync_ena	When set, the LVDS SYNC input is used to sync the PLL N dividers.	1
		10	pll_ena	When set, the PLL is enabled. When cleared, the PLL is bypassed.	0
		9:8	Reserved	Reserved for factory use	00
		7:6	pll_cp(1:0)	PLL pump charge select 00: No charge pump 01: Single pump charge 10: Not used 11: Dual pump charge	00
		5:3	pll_p(2:0)	PLL pre-scaler dividing module control 010: 2 011: 3 100: 4 101: 5 110: 6 111: 7 000: 8	001
		2:0	pll_lfvolt(2:0)	PLL loop filter voltage. This 3-bit read-only indicator has step size of 0.4125 V. The entire range covers from 0 V to 3.3 V. The optimal lock range of the PLL is from 010 to 101 (for example, 0.825 V to 2.063 V). Adjust <i>pll_vco(5:0)</i> for optimal lock range.	NA

Table 37. Register Name: config25 – Address: 0x19, Default: 0x0440

Register Name	Address	Bit	Name	Function	Default Value
config25	0x19	15:8	pll_m(7:0)	M portion of the M/N divider of the PLL. If pll_m<7> = 0, the M divider value has the range of pll_m<6:0>, spanning from 4 to 127. (for example, 0, 1, 2, and 3 are not valid.) If pll_m<7> = 1, the M divider value has the range of 2 x pll_m<6:0>, spanning from 8 to 254. (for example, 0, 2, 4, and 6 are not valid. The M divider has even values only.)	0x04
		7:4	pll_n(3:0)	N portion of the M/N divider of the PLL. 0000: 1 0001: 2 0010: 3 0011: 4 0100: 5 0101: 6 0110: 7 0111: 8 1000: 9 1001: 10 1010: 11 1011: 12 1100: 13 1101: 14 1110: 15 1111: 16	0100
		3:2	pll_vcoitune(1:0)	PLL VCO bias tuning bits. Set to 01 for normal PLL operation	00
		1:0	Reserved	Reserved for factory use	00

Table 38. Register Name: config26 – Address: 0x1A, Default: 0x0020

Register Name	Address	Bit	Name	Function	Default Value
config26	0x1A	15:10	pll_vco(5:0)	VCO frequency coarse-tuning bits.	0000 00
		9	Reserved	Reserved for factory use	0
		8	Reserved	Reserved for factory use	0
		7	bias_sleep	When set, the bias amplifier is put into sleep mode.	0
		6	tsense_sleep	Turns off the temperature sensor when asserted.	0
		5	pll_sleep	When set, the PLL is put into sleep mode.	1
		4	clkrecv_sleep	When asserted, the clock input receiver is put into sleep mode. This affects the OSTR receiver as well.	0
		3	sleepA	When set, the DACA is put into sleep mode.	0
		2	sleepB	When set, the DACB is put into sleep mode.	0
		1	sleepC	When set, the DACC is put into sleep mode.	0
0	sleepD	When set, the DACD is put into sleep mode.	0		

Table 39. Register Name: config27 – Address: 0x1B, Default: 0x0000

Register Name	Address	Bit	Name	Function	Default Value																																														
config27	0x1B	15	extref_ena	Allows the device to use an external reference or the internal reference. 0: Internal reference 1: External reference	0																																														
		14	Reserved	Reserved for factory use	0																																														
		13	Reserved	Reserved for factory use	0																																														
		12	Reserved	Reserved for factory use	0																																														
		11	fuse_sleep	Put the fuses to sleep when set high. Note: Default value is 0. Must be set to 1 for proper operation	0																																														
		10	Reserved	Reserved for factory use	0																																														
		9	Reserved	Reserved for factory use	0																																														
		8	Reserved	Reserved for factory use	0																																														
		7	Reserved	Reserved for factory use	0																																														
		6	Reserved	Reserved for factory use	0																																														
		5:0	atest	ATEST mode allows the user to check for the internal die voltages to ensure the supply voltages are within range. When the ATEST mode is programmed, the internal die voltages can be measured at the TXENA pin. The TXENA pin (N9) must be floating without any pullup or pulldown resistors. In ATEST mode, the TXENA and <i>sif_txenable</i> logic is bypassed, and the output is active at all times.	000000																																														
					<table border="1"> <thead> <tr> <th>Config27, bit<5:0></th> <th>Description</th> <th>Expected Nominal Voltage</th> </tr> </thead> <tbody> <tr><td>00 1110</td><td>DACA AVSS</td><td>0 V</td></tr> <tr><td>00 1111</td><td>DACA DVDD</td><td>1.35 V</td></tr> <tr><td>01 0000</td><td>DACA AVDD</td><td>3.3 V</td></tr> <tr><td>01 0110</td><td>DACB AVSS</td><td>0 V</td></tr> <tr><td>01 0111</td><td>DACB DVDD</td><td>1.35 V</td></tr> <tr><td>01 1000</td><td>DACB AVDD</td><td>3.3 V</td></tr> <tr><td>01 1110</td><td>DACC AVSS</td><td>0 V</td></tr> <tr><td>01 1111</td><td>DACC DVDD</td><td>1.35 V</td></tr> <tr><td>10 0000</td><td>DACC AVDD</td><td>3.3 V</td></tr> <tr><td>10 0110</td><td>DACD AVSS</td><td>0 V</td></tr> <tr><td>10 0111</td><td>DACD DVDD</td><td>1.35 V</td></tr> <tr><td>10 1000</td><td>DACD AVDD</td><td>3.3 V</td></tr> <tr><td>11 0000</td><td>1.3VDIG</td><td>1.3 V</td></tr> <tr><td>00 0101</td><td>1.35VCLK</td><td>1.35 V</td></tr> </tbody> </table>	Config27, bit<5:0>	Description	Expected Nominal Voltage	00 1110	DACA AVSS	0 V	00 1111	DACA DVDD	1.35 V	01 0000	DACA AVDD	3.3 V	01 0110	DACB AVSS	0 V	01 0111	DACB DVDD	1.35 V	01 1000	DACB AVDD	3.3 V	01 1110	DACC AVSS	0 V	01 1111	DACC DVDD	1.35 V	10 0000	DACC AVDD	3.3 V	10 0110	DACD AVSS	0 V	10 0111	DACD DVDD	1.35 V	10 1000	DACD AVDD	3.3 V	11 0000	1.3VDIG	1.3 V	00 0101	1.35VCLK	1.35 V	
		Config27, bit<5:0>	Description	Expected Nominal Voltage																																															
		00 1110	DACA AVSS	0 V																																															
		00 1111	DACA DVDD	1.35 V																																															
		01 0000	DACA AVDD	3.3 V																																															
		01 0110	DACB AVSS	0 V																																															
		01 0111	DACB DVDD	1.35 V																																															
		01 1000	DACB AVDD	3.3 V																																															
01 1110	DACC AVSS	0 V																																																	
01 1111	DACC DVDD	1.35 V																																																	
10 0000	DACC AVDD	3.3 V																																																	
10 0110	DACD AVSS	0 V																																																	
10 0111	DACD DVDD	1.35 V																																																	
10 1000	DACD AVDD	3.3 V																																																	
11 0000	1.3VDIG	1.3 V																																																	
00 0101	1.35VCLK	1.35 V																																																	

Table 40. Register Name: config28 – Address: 0x1C, Default: 0x0000

Register Name	Address	Bit	Name	Function	Default Value
config28	0x1C	15:8	Reserved	Reserved for factory use	0x00
		7:0	Reserved	Reserved for factory use	0x00

Table 41. Register Name: config29 – Address: 0x1D, Default: 0x0000

Register Name	Address	Bit	Name	Function	Default Value
config29	0x1D	15:8	Reserved	Reserved for factory use	0x00
		7:0	Reserved	Reserved for factory use	0x00

Table 42. Register Name: config30 – Address: 0x1E, Default: 0x1111

Register Name	Address	Bit	Name	Function	Default Value
config30	0x1E	15:12	syncsel_qmoffsetAB(3:0)	Selects the syncing source(s) of the AB data path double-buffered QMC offset registers. A 1 in the bit enables the signal as a sync source. More than one sync source is permitted. Bit 15: <i>sif_sync</i> (via <i>config31</i>) Bit 14: SYNC Bit 13: OSTR Bit 12: Auto-sync from register write	0001
		11:8	syncsel_qmoffsetCD(3:0)	Selects the syncing source(s) of the CD data path double-buffered QMC offset registers. A 1 in the bit enables the signal as a sync source. More than one sync source is permitted. Bit 11: <i>sif_sync</i> (via <i>config31</i>) Bit 10: SYNC Bit 9: OSTR Bit 8: Auto-sync from register write	0001
		7:4	syncsel_qmcorrAB(3:0)	Selects the syncing source(s) of the AB data path double buffered QMC correction registers. A 1 in the bit enables the signal as a sync source. More than one sync source is permitted. Bit 7: <i>sif_sync</i> (via <i>config31</i>) Bit 6: SYNC Bit 5: OSTR Bit 4: Auto-sync from register write	0001
		3:0	syncsel_qmcorrCD(3:0)	Selects the syncing source(s) of the CD data path double buffered QMC correction registers. A 1 in the bit enables the signal as a sync source. More than one sync source is permitted. Bit 3: <i>sif_sync</i> (via <i>config31</i>) Bit 2: SYNC Bit 1: OSTR Bit 0: Auto-sync from register write	0001

Table 43. Register Name: config31 – Address: 0x1F, Default: 0x1140

Register Name	Address	Bit	Name	Function	Default Value
config31	0x1F	15:12	syncsel_mixerAB(3:0)	Selects the syncing source(s) of the AB data path double buffered mixer registers. A 1 in the bit enables the signal as a sync source. More than one sync source is permitted. Bit 15: <i>sif_sync</i> (via <i>config31</i>) Bit 14: SYNC Bit 13: OSTR Bit 12: Auto-sync from register write	0001
		11:8	syncsel_mixerCD(3:0)	Selects the syncing source(s) of the CD data path double buffered mixer registers. A 1 in the bit enables the signal as a sync source. More than one sync source is permitted. Bit 11: <i>sif_sync</i> (via <i>config31</i>) Bit 10: SYNC Bit 9: OSTR Bit 8: Auto-sync from register write	0001
		7:4	syncsel_nco(3:0)	Selects the syncing source(s) of the two NCO accumulators. A 1 in the bit enables the signal as a sync source. More than one sync source is permitted. Bit 7: <i>sif_sync</i> (via <i>config31</i>) Bit 6: SYNC Bit 5: OSTR Bit 4: ISTR	0100
		3:2	syncsel_fifo_input(1:0)	Selects either the ISTR or SYNC LVDS signal to be routed to the internal FIFO_ISTR path if <i>syncsel_fifo_in(3:0)</i> is set to be ISTR (i.e. <i>syncsel_fifo_in(3:0)</i> = 0010). In conjunction with <i>config1</i> register bit(8), this allows flexibility of external LVDS signal routing to the internal FIFO. The <i>syncsel_fifo_input(1:0)</i> can only have one bit active at a time. 00: external LVDS ISTR signal to internal FIFO_ISTR path 01: external LVDS SYNC signal to internal FIFO_ISTR path 10: external LVDS ISTR signal to internal FIFO_ISTR path 11: external LVDS SYNC signal to internal FIFO_ISTR path	00
		1	<i>sif_sync</i>	SIF created sync signal. Set to 1 to cause a sync and then clear to 0 to remove it.	0
		0	Reserved	Reserved for factory use	0

Table 44. Register Name: config32 – Address: 0x20, Default: 0x2400

Register Name	Address	Bit	Name	Function	Default Value
config32	0x20	15:12	syncsel_fifo(3:0)	Selects the syncing source(s) of the FIFO input side. A 1 in the bit enables the signal as a sync source. More than one sync source is permitted. Bit 15: <i>sif_sync</i> (via <i>config31</i>) Bit 14: Always zero Bit 13: ISTR Bit 12: SYNC	0010
		11:8	syncsel_fifoout(3:0)	Selects the syncing source(s) of the FIFO output side. A 1 in the bit enables the signal as a sync source. More than one sync source is permitted. <i>clkdiv_sync_ena</i> must be set to 1 for the FIFO output pointer sync to occur. Bit 11: <i>sif_sync</i> (via <i>config31</i>) Bit 10: OSTR – Dual-sync-sources mode Bit 9: ISTR – Single-sync-source mode Bit 8: SYNC – Single-sync-source mode	0100
		7:1	Reserved	Reserved for factory use	0000
		0	clkdiv_sync_sel	Selects the signal source for clock divider synchronization	0
			clkdiv_sync_sel	Sync Source	
			0	OSTR	
			1	ISTR, SYNC, or SIF SYNC, based on <i>syncsel_fifo</i> source selection (<i>config32</i> , bits<15:12>)	

Table 45. Register Name: config33 – Address: 0x21, Default: 0x0000

Register Name	Address	Bit	Name	Function	Default Value
config33	0x21	15:0	Reserved	Reserved for factory use	0x0000

Table 46. Register Name: config34 – Address: 0x22, Default: 0x1B1B

Register Name	Address	Bit	Name	Function	Default Value
config34	0x22	15:14	pathA_in_sel(1:0)	Selects the word used for the A channel path	00
		13:12	pathB_in_sel(1:0)	Selects the word used for the B channel path	01
		11:10	pathC_in_sel(1:0)	Selects the word used for the C channel path	10
		9:8	pathD_in_sel(1:0)	Selects the word used for the D channel path	11
		7:6	DACA_out_sel(1:0)	Selects the word used for the DACA output	00
		5:4	DACB_out_sel(1:0)	Selects the word used for the DACB output	01
		3:2	DACC_out_sel(1:0)	Selects the word used for the DACC output	10
		1:0	DACD_out_sel(1:0)	Selects the word used for the DACD output	11

Table 47. Register Name: config35 – Address: 0x23, Default: 0xFFFF

Register Name	Address	Bit	Name	Function	Default Value	
config35	0x23	15:0	sleep_cntl(15:0)	Controls the routing of the CMOS SLEEP signal (pin N11) to different blocks. When a bit in this register is set, the SLEEP signal is sent to the corresponding block. The block is only disabled when the SLEEP is logic HIGH and the corresponding bit is set to 1. These bits do not override the SIF bits in <i>config26</i> that control the same sleep function.	0xFFFF	
				sleep_cntl(bit)		Function
				15		DACA sleep
				14		DACB sleep
				13		DACC sleep
				12		DACD sleep
				11		Clock receiver sleep
				10		PLL sleep
				9		LVDS data sleep
				8		LVDS control sleep
				7		Temp sensor sleep
				6		Reserved
				5		Bias amplifier sleep
All others	Not used					

Table 48. Register Name: config36 – Address: 0x24, Default: 0x0000

Register Name	Address	Bit	Name	Function	Default Value
config36	0x24	15:13	datadly(2:0)	Controls the delay of the data inputs through the LVDS receivers. Each LSB adds approximately 40 ps 0: Minimum	000
		12:10	clkdly(2:0)	Controls the delay of the data clock through the LVDS receivers. Each LSB adds approximately 40 ps 0: Minimum	000
		9:0	Reserved	Reserved for factory use	0x000

Table 49. Register Name: config37 – Address: 0x25, Default: 0x7A7A

Register Name	Address	Bit	Name	Function	Default Value
config37	0x25	15:0	iotest_pattern0	Dataword0 in the IO test pattern. It is used with the seven other words to test the input data. At the start of the IO test pattern, this word should be aligned with rising edge of ISTR or SYNC signal to indicate sample 0.	0x7A7A

Table 50. Register Name: config38 – Address: 0x26, Default: 0xB6B6

Register Name	Address	Bit	Name	Function	Default Value
config38	0x26	15:0	iotest_pattern1	Dataword1 in the IO test pattern. It is used with the seven other words to test the input data.	0xB6B6

Table 51. Register Name: config39 – Address: 0x27, Default: 0xEAEA

Register Name	Address	Bit	Name	Function	Default Value
config39	0x27	15:0	iotest_pattern2	Dataword2 in the IO test pattern. It is used with the seven other words to test the input data.	0xEAEA

Table 52. Register Name: config40 – Address: 0x28, Default: 0x4545

Register Name	Address	Bit	Name	Function	Default Value
config40	0x28	15:0	iotest_pattern3	Dataword3 in the IO test pattern. It is used with the seven other words to test the input data.	0x4545

Table 53. Register Name: config41 – Address: 0x29, Default: 0x1A1A

Register Name	Address	Bit	Name	Function	Default Value
config41	0x29	15:0	iotest_pattern4	Dataword4 in the IO test pattern. It is used with the seven other words to test the input data.	0x1A1A

Table 54. Register Name: config42 – Address: 0x2A, Default: 0x1616

Register Name	Address	Bit	Name	Function	Default Value
config42	0x2A	15:0	iotest_pattern5	Dataword5 in the IO test pattern. It is used with the seven other words to test the input data.	0x1616

Table 55. Register Name: config43 – Address: 0x2B, Default: 0xAAAA

Register Name	Address	Bit	Name	Function	Default Value
config43	0x2B	15:0	iotest_pattern6	Dataword6 in the IO test pattern. It is used with the seven other words to test the input data.	0xAAAA

Table 56. Register Name: config44 – Address: 0x2C, Default: 0xC6C6

Register Name	Address	Bit	Name	Function	Default Value
config44	0x2C	15:0	iotest_pattern7	Dataword7 in the IO test pattern. It is used with the seven other words to test the input data.	0xC6C6

Table 57. Register Name: config45 – Address: 0x2D, Default: 0x0004

Register Name	Address	Bit	Name	Function	Default Value
config45	0x2D	15	Reserved	Reserved for factory use	0
		14	ostrtodig_sel	When set, the OSTR signal is passed directly to the digital block. This is the signal that is used to clock the dividers.	0
		13	ramp_ena	When set, a ramp signal is inserted in the input data at the FIFO input.	0
		12:1	Reserved	Reserved for factory use	0000 0000 0010
		0	sifdac_ena	When set, the DAC output is set to the value in <i>sifdac(15:0)</i> in register <i>config48</i> .	0

Table 58. Register Name: config46 – Address: 0x2E, Default: 0x0000

Register Name	Address	Bit	Name	Function	Default Value
config46	0x2E	15:0	Reserved	Reserved for factory use	0x00

Table 59. Register Name: config47 – Address: 0x2F, Default: 0x0000

Register Name	Address	Bit	Name	Function	Default Value
config47	0x2F	15:0	Reserved	Reserved for factory use	0x00

Table 60. Register Name: config48 – Address: 0x30, Default: 0x0000

Register Name	Address	Bit	Name	Function	Default Value
config48	0x30	15:0	sifdac(15:0)	Value sent to the DACs when <i>sifdac_ena</i> is asserted. DATACLK must be running to latch this value into the DACs. The format would be based on twos in register <i>config2</i> .	0x0000

Table 61. Register Name: Version– Address: 0x7F, Default: 0x5409 (Read Only)

Register Name	Address	Bit	Name	Function	Default Value
version	0x7F	15:10	Reserved	Reserved for factory use	0101 01
		9	Reserved	Reserved for factory use	0
		8:7	Reserved	Reserved for factory use	00
		6:5	die_id_34SH84(1:0)	Returns 01 for DAC34SH84	01
		4:3	deviceid(1:0)	Returns 01 for DAC34SH84	01
		2:0	versionid(2:0)	A hardwired register that contains the version of the chip	001

8 Application and Implementation

NOTE

Information in the following applications sections is not part of the TI component specification, and TI does not warrant its accuracy or completeness. TI's customers are responsible for determining suitability of components for their purposes. Customers should validate and test their design implementation to confirm system functionality.

8.1 Application Information

The DAC34SH84 is a dual 16-bit DAC with max input data rate of up to 750 MSPS per DAC and max DAC update rate of 1.5 GSPS after the final, selectable interpolation stages. With build-in interpolation filter of 2x, 4x, 8x, and 16x options, the lower input data rate can be interpolated all the way to 1.5 GSPS. This allows the DAC to update the samples at higher rate, and pushes the DAC images further away to relax anti-image filter specification due to the increased Nyquist bandwidth. With integrated coarse and fine mixers, baseband signal can be upconverted to an intermediate frequency (IF) signal between the baseband processor and post-DAC analog signal chains.

The DAC can output baseband or IF when connected to post-DAC analog signals chain components such as transformers or IF amplifiers. When used in conjunction with TI RF quadrature modulator such as the TRF3705, the DAC and RF modulator can function as a set of baseband or IF upconverter. With integrated QMC circuits, the LO offset and the sideband artifacts can be properly corrected in the direct up-conversion applications. The DAC34SH84 provides the bandwidth, performance, small footprint, and lower power consumption needed for multi-mode 2G/3G/4G cellular base stations to migrate to more advanced technologies, such as LTE-Advanced and carrier aggregation on multiple antennas.

8.2 Typical Applications

8.2.1 IF Based LTE Transmitter

Figure 88 shows an example block diagram for a direct conversion radio. The design requires a single carrier, 20-MHz LTE signal. The system has digital-predication (DPD) to correct up to 5th order distortion so the total DAC output bandwidth is 100 MHz. Interpolation is used to output the signal at highest sampling rate possible to simplify the analog filter requirements and move high order harmonics out of band (due to wider Nyquist zone). The internal PLL is used to generate the final DAC output clock from a reference clock of 491.52 MHz.

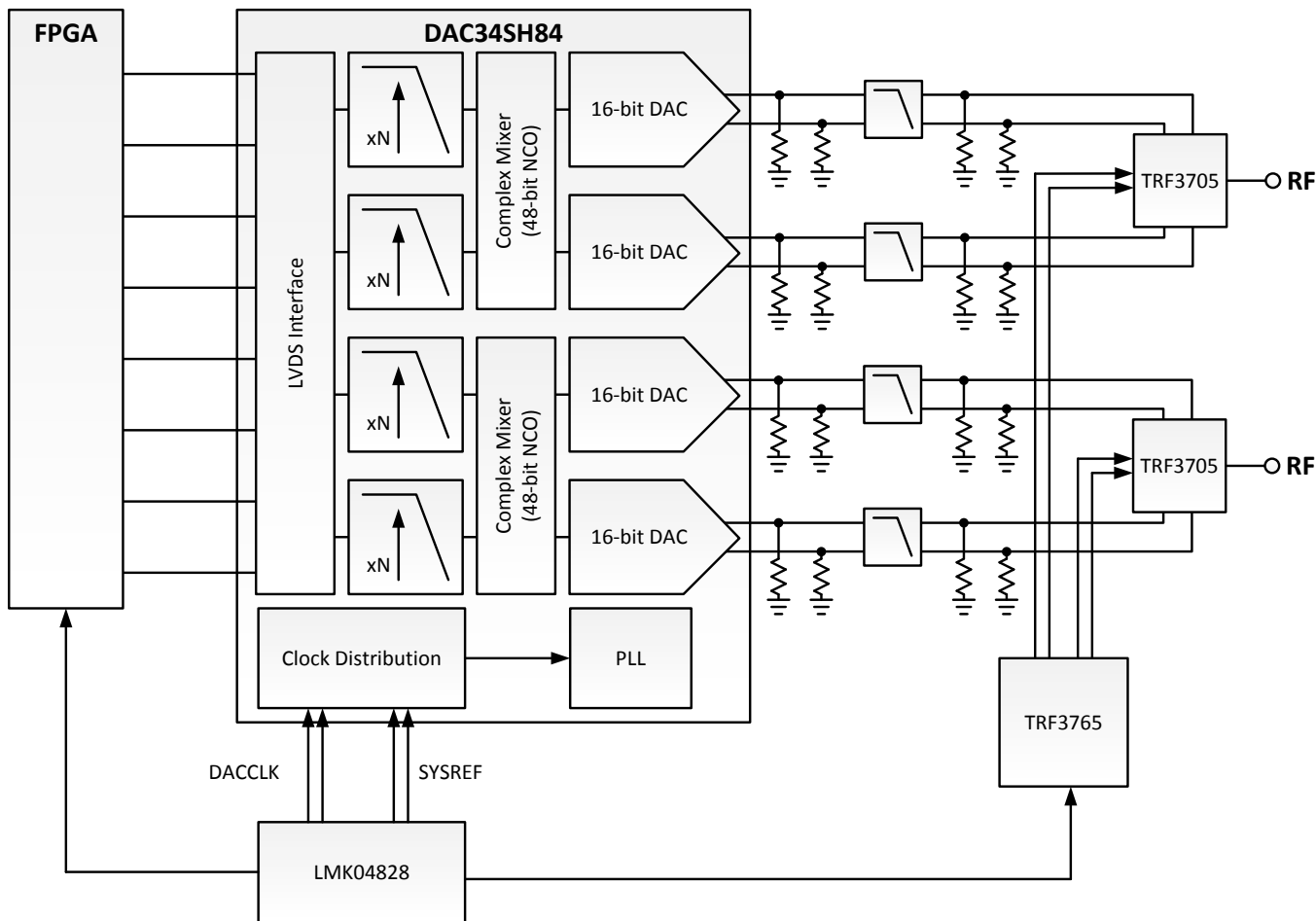

Figure 88. Dual Low-IF Wideband LTE Transmitter Diagram

8.2.1.1 Design Requirements

For this design example, use the parameters listed in Table 62 as the input parameters.

Table 62. Design Parameters

DESIGN PARAMETER	EXAMPLE VALUE
Signal Bandwidth (BW_{signal})	20 MHz
Total DAC Output Bandwidth (BW_{total})	100 MHz
DAC PLL	On
DAC PLL Reference Frequency	491.52 MHz
Maximum FPGA LVDS Rate	491.52 Mbps

8.2.1.2 Detailed Design Procedure

8.2.1.2.1 Data Input Rate

Nyquist theory states that the data rate must be at least two times the highest signal frequency. The data will be sent to the DAC as complex baseband data. Due to the quadrature nature of the signal, each in-phase (I component) and quadrature (Q component) need to have 50 MHz of bandwidth to construct 100 MHz of complex bandwidth. Since the interpolation filter design is not the ideal half-band filter design with infinite roll-off at $F_{DATA}/2$ (refer to FIR Filters section for more detail), the filter limits the useable input bandwidth to about 40 percent of F_{DATA} . Therefore, the minimum data input rate is 125 MSPS. Since the standard telecom data rate is typically multiples of 30.72 MSPS, the DAC input data rate is chosen to be eight times of 30.72 MSPS, which is 245.76 MSPS.

8.2.1.2.2 Interpolation

It is desired to use the highest DAC output rate as possible to move the DAC images further from the signal of interest to ease analog filter requirement. The DAC output rate must be greater than two times the highest output frequency of 200 MHz, which is greater than 400 MHz. [Table 63](#) shows the possible DAC output rates based on the data input rate and available interpolation settings. The DAC image frequency is also listed.

Table 63. Interpolation

F_{DATA}	INTERPOLATION	F_{DAC}	POSSIBLE?	LOWEST IMAGE FREQUENCY	DISTANCE FROM BAND OF INTEREST
245.76 MSPS	1	245.76 MSPS	No	N/A	N/A
245.76 MSPS	2	491.52 MSPS	Yes	318.64 MHz	145.76 MHz
245.76 MSPS	4	983.04 MSPS	Yes	810.16 MHz	637.28 MHz
245.76 MSPS	8	1966.08 MSPS	No	N/A	N/A
245.76 MSPS	16	3932.16 MSPS	No	N/A	N/A

8.2.1.2.3 LO Feedthrough and Sideband Correction

For typical IF based systems, the IF location is selected such that the image location and the LO feedthrough location is far from the signal location. The minimum distance is based on the bandpass filter roll-off and attenuation level at the LO feedthrough and image location. If sufficient attenuation level of these two artifacts meets the system requirement, then further digital cancellation of these artifacts may not be needed.

Although the I/Q modulation process will inherently reduce the level of the RF sideband signal, an IF based transmitter without sufficient RF image rejection capabilities or an zero-IF based system (detail in the next section) will likely need additional sideband suppression to maximize performance. Further, any mixing process will result in some feedthrough of the LO source. The DAC34SH84 has build-in digital features to cancel both the LO feedthrough and sideband signal. The LO feedthrough is corrected by adding a DC offset to the DAC outputs until the LO feedthrough power is suppressed. The sideband suppression can be improved by correcting the gain and phase differences between the I and Q analog outputs through the digital QMC block. Besides gain and phase differences between the I and Q analog outputs, group delay differences may also be present in the signal path and are typically contributed by group delay variations of post DAC image reject analog filters and PCB trace variations. Since delay in time translates to higher order linear phase variation, the sideband of a wideband system may not be completely suppressed by typical digital QMC block. The system designer may implement additional linear group delay compensation in the host processor to the DAC to perform higher order sideband suppression.

8.2.1.3 Application Curves

The ACPR performance for LTE 20 MHz TM1.1 are shown in Figure 89, Figure 90, Figure 90, and Figure 90. The figures provide comparisons between two major LTE bands such as 2.14 GHz and 2.655 GHz, and also comparisons between two different DAC clocking options such as DAC on-chip PLL mode and external clocking mode.

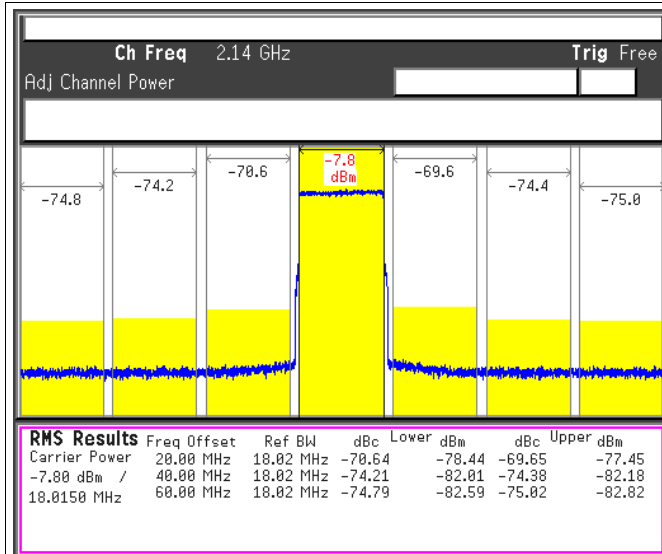

DAC Output IF = 122.88 MHz, LO = 2017.12 MHz, DAC Clock = External Clock Source from LMK04806

Figure 89. 20MHz TM1.1 LTE Carrier at 2.14GHz

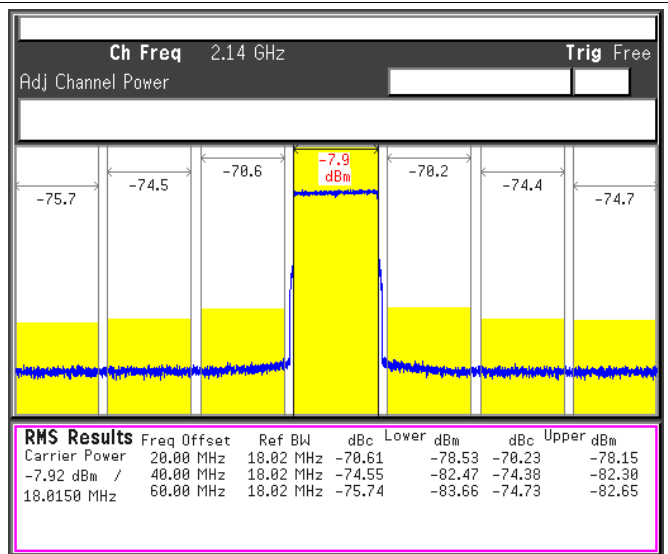

DAC Output IF = 122.88 MHz, LO = 2017.12 MHz, DAC Clock = DAC34SH84 On-Chip PLL

Figure 90. 20MHz TM1.1 LTE Carrier at 2.14GHz

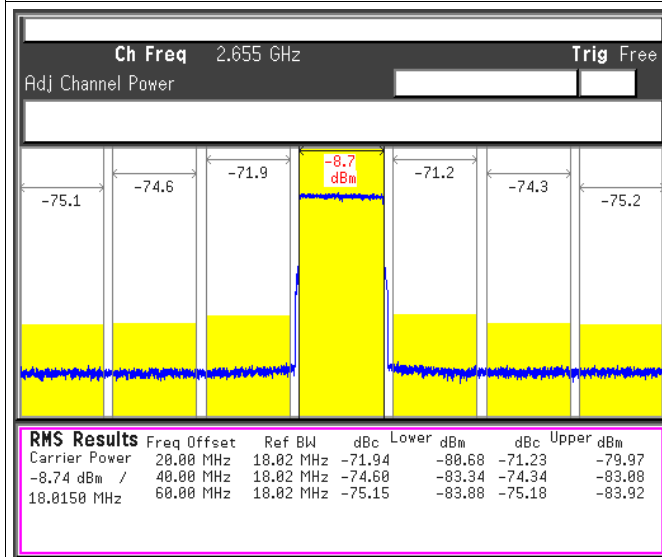

DAC Output IF = 122.88 MHz, LO = 2532.12 MHz, DAC Clock = External Clock Source from LMK04806

Figure 91. 20MHz TM1.1 LTE Carrier at 2.655GHz

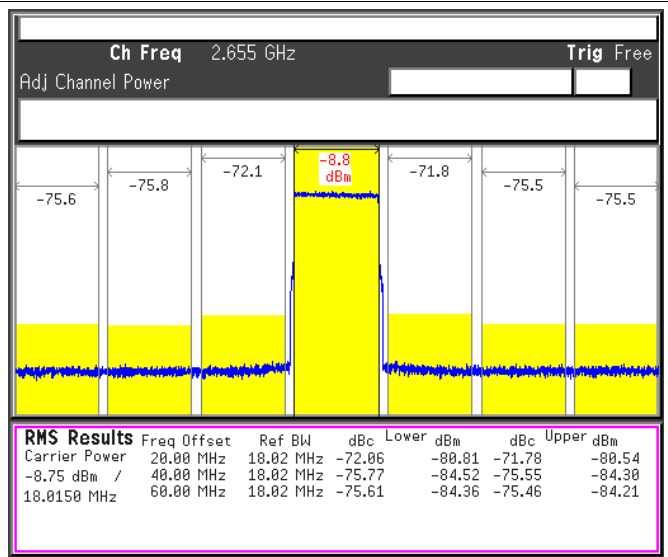

DAC Output IF = 122.88 MHz, LO = 2532.12 MHz, DAC Clock = DAC34SH84 On-Chip PLL

Figure 92. 20MHz TM1.1 LTE Carrier at 2.655GHz

8.2.2 Direct Upconversion (Zero IF) LTE Transmitter

Figure 88 shows an example block diagram for a direct conversion radio. The design specification requires that the desired output bandwidth is 100 MHz, which could be, for instance, a typical LTE signal. The system has DPD to correct up to 5th order distortion so the total DAC output bandwidth is 500 MHz. Interpolation is used to output the signal at the highest sampling rate possible to simplify the analog filtering requirements and move high order harmonics out of band (due to wider Nyquist zone). The DAC sampling clock is provided by high quality clock synthesizer such as the LMK0480x family.

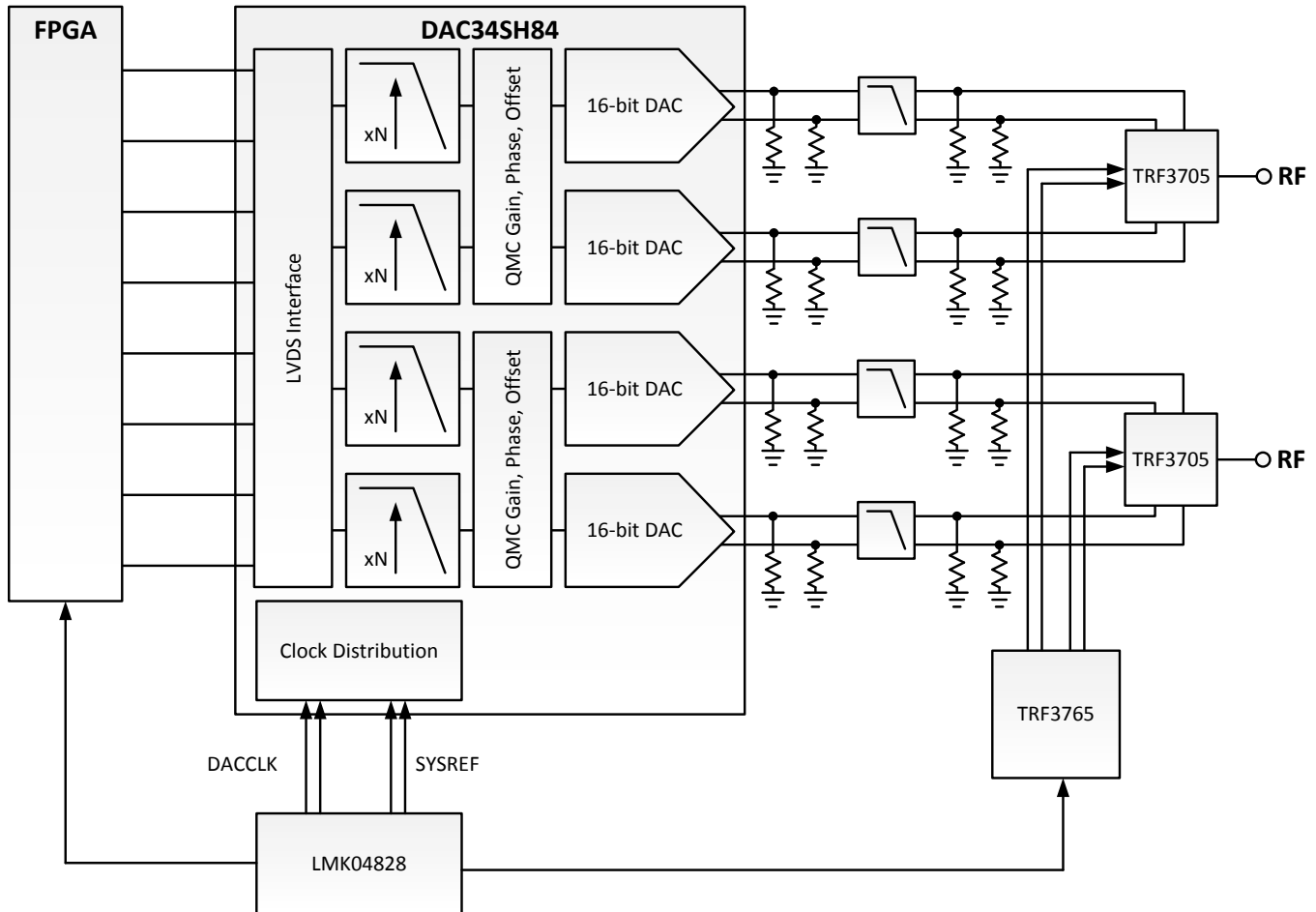

Figure 93. Zero LTE Transmitter Diagram

8.2.2.1 Design Requirements

For this design example, use the parameters listed in Table 64 as the input parameters.

Table 64. Design Parameters

DESIGN PARAMETER	EXAMPLE VALUE
Signal Bandwidth (BW_{signal})	100 MHz
Total DAC Output Bandwidth (BW_{total})	500 MHz
DAC PLL	Off
Maximum FPGA LVDS Rate	1228.8 Mbps

8.2.2.2 Detailed Design Procedure

8.2.2.2.1 Data Input Rate

Nyquist theory states that the data rate must be at least two times the highest signal frequency. The data will be sent to the DAC as complex baseband data. Due to the quadrature nature of the signal, each in-phase (I component) and quadrature (Q component) need to have 250 MHz of bandwidth to construct 500 MHz of complex bandwidth. Since the interpolation filter design is not the ideal half-band filter design with infinite roll-off at $F_{DATA}/2$ (refer to [FIR Filters](#) section for more detail), the filter limits the useable input bandwidth to about 44 percent of F_{DATA} with less than 0.1dB of FIR filter roll-off. Therefore, the minimum data input rate is 568 MSPS. Since the standard telecom data rate is typically multiples of 30.72 MSPS, the DAC input data rate is chosen to be 20 times of 30.72 MSPS, which is 614.4 MSPS. For the DAC34SH84, input data rate of 737.28 MSPS may also be used to meet additional bandwidth demand. This particular setting requires higher speed grade ASIC/FPGA that supports LVDS bus rate of 1474.56 Mbps minimum.

8.2.2.2.2 Interpolation

It is desired to use the highest DAC output rate as possible to move the DAC images further from the signal of interest to ease analog filter requirement. The DAC output rate must be greater than two times the highest output frequency of 250 MHz, which is greater than 500 MHz. The table below shows the possible DAC output rates based on the data input rate and available interpolation settings. The DAC image frequency is also listed.

Table 65. Interpolation

F_{DATA}	INTERPOLATION	F_{DAC}	POSSIBLE?	LOWEST IMAGE FREQUENCY	DISTANCE FROM BAND OF INTEREST
614.4 MSPS	1	614.4 MSPS	Yes	364.4 MHz	114.4 MHz
614.4 MSPS	2	1228.8 MSPS	Yes	978.8 MHz	728.8 MHz
614.4 MSPS	4	2457.6 MSPS	No	N/A	N/A
614.4 MSPS	8	4915.2 MSPS	No	N/A	N/A
614.4 MSPS	16	9830.4 MSPS	No	N/A	N/A

8.2.2.2.3 LO Feedthrough and Sideband Correction

Refer to [LO Feedthrough and Sideband Correction](#) section of IF based LTE Transmitter design.

DAC34SH84

SLAS808E – FEBRUARY 2012 – REVISED SEPTEMBER 2015

www.ti.com

8.2.2.3 Application Curves

The ACPR performance for LTE 20MHz TM1.1 are shown in [Figure 94](#) and [Figure 95](#). The figures provide comparisons between two major LTE bands such as 2.14 GHz and 2.655 GHz with DAC clocking option set to external clocking mode.

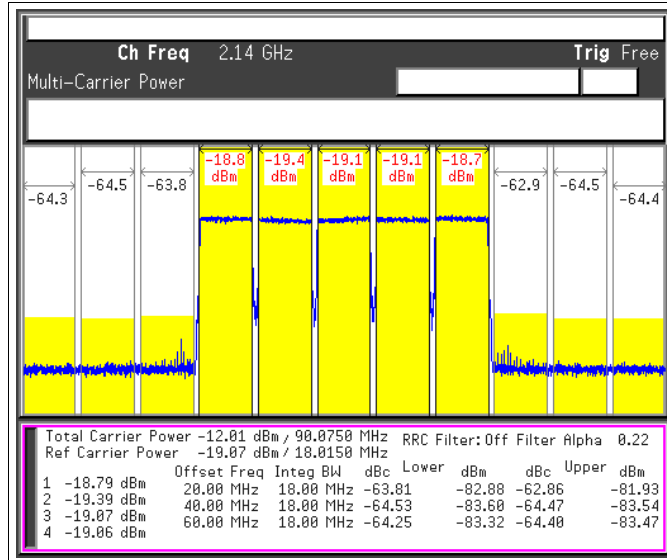

DAC Output IF = 0 MHz, LO = 2140 MHz, DAC Clock = External Clock Source from LMK04806

Figure 94. 5x20MHz TM1.1 LTE Carrier at 2.14GHz

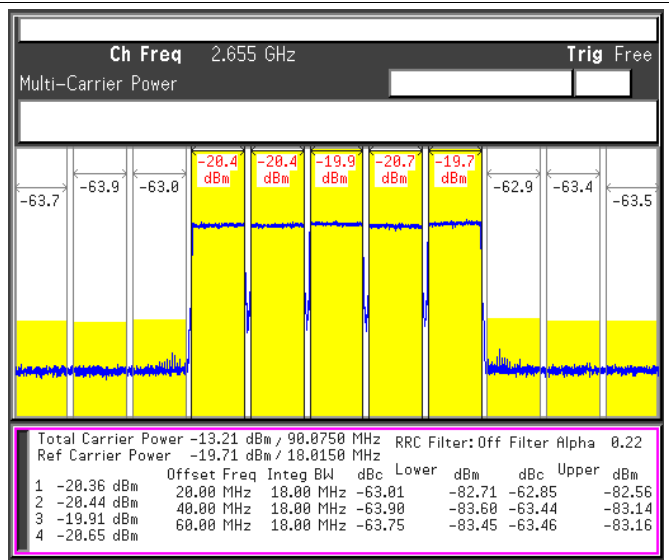

DAC Output IF = 0 MHz, LO = 2655 MHz, DAC Clock = External Clock Source from LMK04806

Figure 95. 5x20MHz TM1.1 LTE Carrier at 2.655GHz

9 Power Supply Recommendations

As shown in Figure 96, the DAC34SH84 device has various power rails and has three primary voltages of 1.3 V, 1.35 V, and 3.3 V. Some of the DAC power rails such as CLKVDD and AVDD are more noise sensitive than other rails because they are mainly powering the switch drivers for the current switch array and the current bias circuits, respectively. These circuits are the main analog DAC core. Any power supply noises such as switching power supply ripple may be modulated directly onto the signal of interest. These two power rails should be powered by low noise power supplies such as LDO. Powering the rail directly with switching power supplies is not recommended for these two rails.

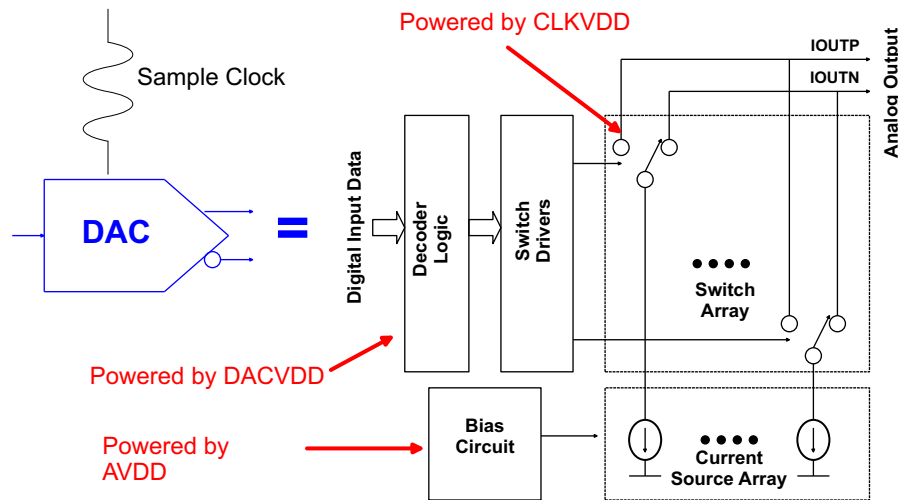

Figure 96. Interpolation Filters, NCOs, and QMC Blocks Powered by DIGVDD

With the DAC34SH84 being a mixed signal device, the device contains circuits that bridges the digital section and the analog section. The DACVDD powers these sections. System designer can design this rail in secondary priority. Powering the rail with LDO is recommended. Unless system designer pays special care to supply filtering and power supply routing/placement, powering the rail directly with switching power supplies is not recommended for this rail.

Since digital circuits have more inherent noise immunity than analog circuits, the power supply noise requirements for DIGVDD of the digital section of the device may be relaxed and placed at a lower priority. Depending on the spur level requirement, routing and placement of the power supply, power the rail directly with switching power supplies can be possible. With the digital logics running, the DIGVDD rail may draw significant current. If the power supply traces and filtering network have significant DC resistance loss (for example, DCR), then the final supply voltage seen by the DIGVDD rail may not be sufficient to meet the minimum power supply level. For instance, with 450 mA of DIGVDD current and about 0.1 Ω of DCR from the ferrite bead, the final supply voltage at the DIGVDD pins may be $1.3\text{ V} - 0.045\text{ V} = 1.255\text{ V}$. This is fairly close to the minimum supply voltage range of 1.25 V. System designer may need to elevate the power supply voltage according to the DCR level or design a feedback network for the power supply to account for associated voltage drop. To ensure power supply accuracy and to account for power supply filter network loss at operating conditions, the use of the ATEST function in register config27 to check the internal power supply nodes is recommended.

The table below is a summary of the various power supply nodes of the DAC. Care should be taken to keep clean power supplies routing away from noisy digital supplies. It is recommended to use at least two power layers. Power supplies for digital circuits tend to have more switching activities and are typically noisier, and system designer should avoid sharing the digital power rail (for example, power supplies for FPGA or DIGVDD of DAC34SH84) with the analog power rail (for example, CLKVDD and AVDD of DAC34SH84). Avoid placing noisy supplies and clean supplies on adjacent board layers and use a ground layer between these two supplies if possible. All supply pins should be decoupled as close to the pins as possible by using small value capacitors, with larger bulk capacitors placed further away and near the power supply source.

Table 66. Power Rails

POWER RAILS	TYPICAL VOLTAGE	NOISE SENSITIVITY	RECOMMENDATIONS	POWER SUPPLY DESIGN PRIORITY
CLKVDD	1.35 V	High	Provide clean supply to the rail. Avoid spurious noise or coupling from other supplies	High
AVDD	3.3 V	High	Provide clean supply to the rail. Avoid spurious noise or coupling from other supplies	High
DACVDD	1.35 V	Medium	Provide clean supply to the rail. Avoid spurious noise or coupling from other supplies	Medium
DIGVDD	1.3 V	Low	Keep Away from other noise sensitive nodes in placement and routing.	Low

10 Layout

10.1 Layout Guidelines

The design of the PCB is critical to achieve the full performance of the DAC34SH84 device. Defining the PCB stackup should be the first step in the board design. Experience has shown that at least six layers are required to adequately route all required signals to and from the device. Each signal routing layer must have an adjacent solid ground plane to control signal return paths to have minimal loop areas and to achieve controlled impedances for microstrip and stripline routing. Power planes must also have adjacent solid ground planes to control supply return paths. Minimizing the space between supply and ground planes improves performance by increasing the distributed decoupling.

Although the DAC34SH84 device consists of both analog and digital circuitry, TI highly recommends solid ground planes that encompass the device and its input and output signal paths. TI does not recommend split ground planes that divide the analog and digital portions of the device. Split ground planes may improve performance if a nearby, noisy, digital device is corrupting the ground reference of the analog signal path. When split ground planes are employed, one must carefully control the supply return paths and keep the paths on top of their respective ground reference planes.

Quality analog output signals and input conversion clock signal path layout is required for full dynamic performance. Symmetry of the differential signal paths and discrete components in the path is mandatory, and symmetrical shunt-oriented components should have a common grounding via. The high frequency requirements of the analog output and clock signal paths necessitate using differential routing with controlled impedances and minimizing signal path stubs (including vias) when possible.

Coupling onto or between the clock and output signals paths should be avoided using any isolation techniques available including distance isolation, orientation planning to prevent field coupling of components like inductors and transformers, and providing well coupled reference planes. Via stitching around the clock signal path and the input analog signal path provides a quiet ground reference for the critical signal paths and reduces noise coupling onto these paths. Sensitive signal traces must not cross other signal traces or power routing on adjacent PCB layers, rather a ground plane must separate the traces. If necessary, the traces should cross at 90° angles to minimize crosstalk.

The substrate (dielectric) material requirements of the PCB are largely influenced by the speed and length of the high speed serial lanes. Affordable and common FR4 varieties are adequate in most cases.

Coupling of ambient signals into the signal path is reduced by providing quiet, close reference planes and by maintaining signal path symmetry to ensure the coupled noise is common-mode. Faraday caging may be used in very noise environment and high dynamic range applications to isolate the signal path.

The following layout guidelines correspond to the layout shown in [Figure 97](#).

1. DAC output termination resistors should be placed as close to the output pins as possible to provide a DC path to ground and set the source impedance matching.
2. For DAC on-chip PLL clocking mode, if the external loop filter is not used, leave the loop filter pin floating without any board routing nearby. Signals coupling to this node may cause clock mixing spurs in the DAC output.
3. Route the high speed LVDS lanes as impedance-controlled, tightly-coupled, differential traces.

Layout Guidelines (continued)

4. Maintain a solid ground plane under the LVDS lanes without any ground plane splits.
5. Simulation of the LVDS channel with DAC34SH84 IBIS model is recommended to verify good eye opening of the data patterns.
6. Keep the OSTR signal routing away from the DACCLK routing to reduce coupling.
7. Keep routing for RBIAS short, for instance a resistor can be placed on the board directly connecting the RBIAS pin to the ground layer.

The following layout guidelines correspond to the layouts shown in [Figure 98](#) and [Figure 99](#).

1. Noise power supplies should be routed away from clean supplies. Use two power plane layers, preferably with a ground layer in between.
2. As shown in [Figure 98](#) and [Figure 99](#), both layers three and four are designated for power supply planes. The DAC analog powers are all in the same layer to avoid coupling with each other, and the planes are copied from layer three to layer four for double the copper coverage area.
3. Decoupling capacitors should be placed as close to the supply pins as possible. For instance, a capacitor can be placed on the bottom of the board directly connecting the supply pin to a ground layer.

10.1.1 Assembly

Information regarding the package and assembly of the ZAY package version of the DAC34SH84 can be found at the end of the data sheet and also on the following application note: [SPRAA99](#)

10.2 Layout Examples

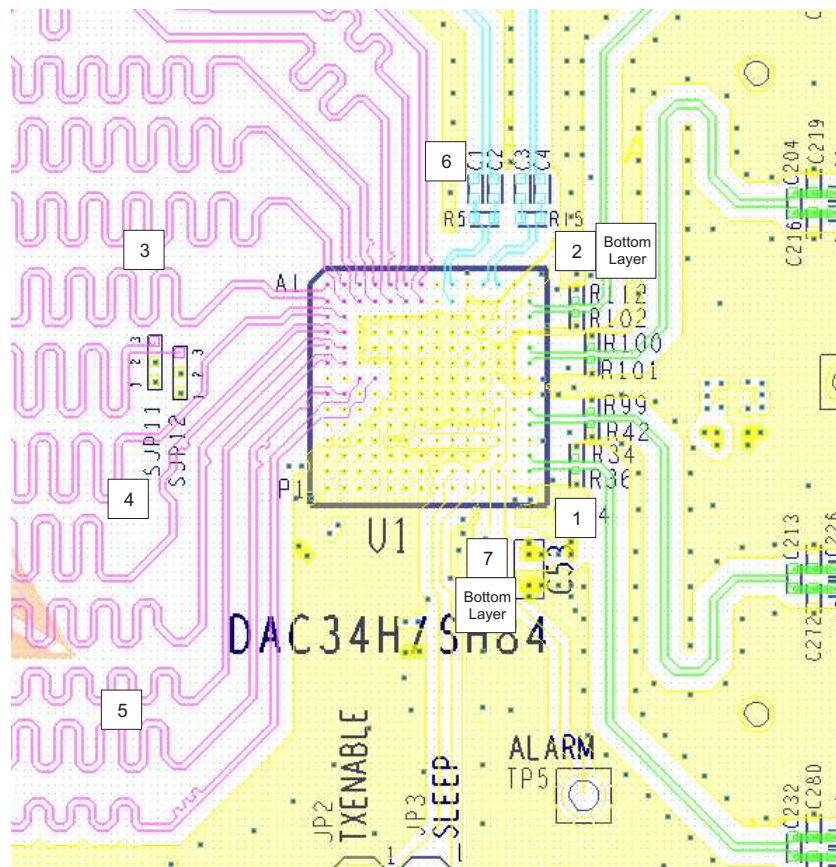

Figure 97. Top Layer of DAC34SH84 Layout Showing High Speed Signals such as LVDS Bus, DACCLK, OSTR, and DAC Outputs. Layout Example from TSW3085EVM Rev D

Layout Examples (continued)

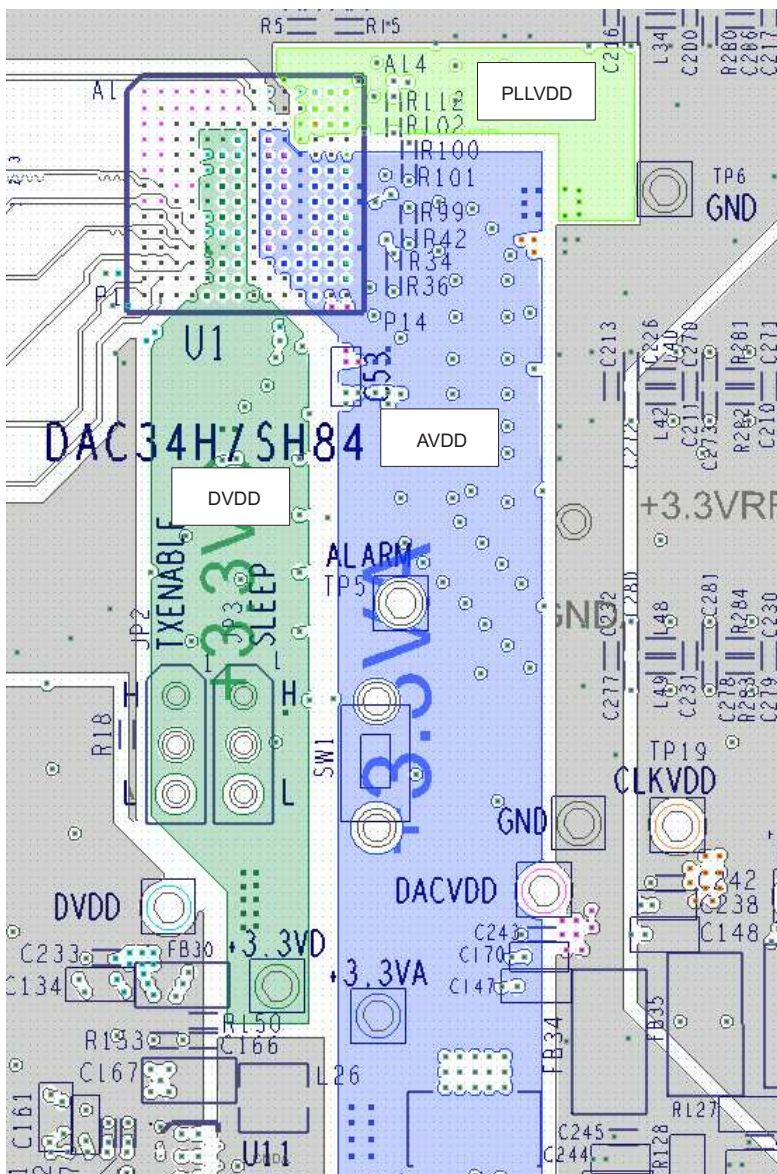

Figure 99. Sixth Layer of DAC34SH84 Layout Showing Power Layers. Layout Example from DAC34SH84EVM Rev H

11 Device and Documentation Support

11.1 Device Support

11.1.1 Third-Party Products Disclaimer

TI'S PUBLICATION OF INFORMATION REGARDING THIRD-PARTY PRODUCTS OR SERVICES DOES NOT CONSTITUTE AN ENDORSEMENT REGARDING THE SUITABILITY OF SUCH PRODUCTS OR SERVICES OR A WARRANTY, REPRESENTATION OR ENDORSEMENT OF SUCH PRODUCTS OR SERVICES, EITHER ALONE OR IN COMBINATION WITH ANY TI PRODUCT OR SERVICE.

11.1.2 Device Nomenclature

11.1.2.1 Definition of Specifications

Adjacent-Carrier Leakage Ratio (ACLR): Defined for a 3.84-Mcps 3GPP W-CDMA input signal measured in a 3.84-MHz bandwidth at a 5-MHz offset from the carrier with a 12-dB peak-to-average ratio

Analog and Digital Power Supply Rejection Ratio (APSSR, DPSSR): Defined as the percentage error in the ratio of the delta IOUT and delta supply voltage normalized with respect to the ideal IOUT current

Differential Nonlinearity (DNL): Defined as the variation in analog output associated with an ideal 1-LSB change in the digital input code

Gain Drift: Defined as the maximum change in gain, in terms of ppm of full-scale range (FSR) per °C, from the value at ambient (25°C) to values over the full operating temperature range

Gain Error: Defined as the percentage error (in FSR%) for the ratio between the measured full-scale output current and the ideal full-scale output current

Integral Nonlinearity (INL): Defined as the maximum deviation of the actual analog output from the ideal output, determined by a straight line drawn from zero scale to full scale

Intermodulation Distortion (IMD3): The two-tone IMD3 is defined as the ratio (in dBc) of the third-order intermodulation distortion product to either fundamental output tone.

Offset Drift: Defined as the maximum change in dc offset, in terms of ppm of full-scale range (FSR) per °C, from the value at ambient (25°C) to values over the full operating temperature range

Offset Error: Defined as the percentage error (in FSR%) for the ratio between the measured mid-scale output current and the ideal mid-scale output current

Output Compliance Range: Defined as the minimum and maximum allowable voltage at the output of the current-output DAC. Exceeding this limit may result in reduced reliability of the device or adversely affect distortion performance.

Reference Voltage Drift: Defined as the maximum change of the reference voltage in ppm per degree Celsius from the value at ambient (25°C) to values over the full operating temperature range

Spurious-Free Dynamic Range (SFDR): Defined as the difference (in dBc) between the peak amplitude of the output signal and the peak spurious signal within the first Nyquist zone

Noise Spectral Density (NSD): Defined as the difference of power (in dBc) between the output tone signal power and the noise floor of 1-Hz bandwidth within the first Nyquist zone

11.2 Documentation Support

11.2.1 Related Documentation

- *DAC34H84 EVM* User's Guide ([SLAU338](#))
- *nFBGA Packaging* Application Report ([SPRAA99](#))

11.3 Community Resources

The following links connect to TI community resources. Linked contents are provided "AS IS" by the respective contributors. They do not constitute TI specifications and do not necessarily reflect TI's views; see TI's [Terms of Use](#).

TI E2E™ Online Community *TI's Engineer-to-Engineer (E2E) Community*. Created to foster collaboration among engineers. At e2e.ti.com, you can ask questions, share knowledge, explore ideas and help solve problems with fellow engineers.

Design Support *TI's Design Support* Quickly find helpful E2E forums along with design support tools and contact information for technical support.

11.4 Trademarks

E2E is a trademark of Texas Instruments.
All other trademarks are the property of their respective owners.

11.5 Electrostatic Discharge Caution



These devices have limited built-in ESD protection. The leads should be shorted together or the device placed in conductive foam during storage or handling to prevent electrostatic damage to the MOS gates.

11.6 Glossary

[SLYZ022](#) — *TI Glossary*.

This glossary lists and explains terms, acronyms, and definitions.

12 Mechanical, Packaging, and Orderable Information

The following pages include mechanical, packaging, and orderable information. This information is the most current data available for the designated devices. This data is subject to change without notice and revision of this document. For browser-based versions of this data sheet, refer to the left-hand navigation.

PACKAGING INFORMATION

Orderable Device	Status (1)	Package Type	Package Drawing	Pins	Package Qty	Eco Plan (2)	Lead/Ball Finish (6)	MSL Peak Temp (3)	Op Temp (°C)	Device Marking (4/5)	Samples
DAC34SH84IZAY	ACTIVE	NFBGA	ZAY	196	160	Green (RoHS & no Sb/Br)	SNAGCU	Level-3-260C-168 HR	-40 to 85	DAC34SH84I	Samples
DAC34SH84IZAYR	ACTIVE	NFBGA	ZAY	196	1000	Green (RoHS & no Sb/Br)	SNAGCU	Level-3-260C-168 HR	-40 to 85	DAC34SH84I	Samples

(1) The marketing status values are defined as follows:

ACTIVE: Product device recommended for new designs.

LIFEBUY: TI has announced that the device will be discontinued, and a lifetime-buy period is in effect.

NRND: Not recommended for new designs. Device is in production to support existing customers, but TI does not recommend using this part in a new design.

PREVIEW: Device has been announced but is not in production. Samples may or may not be available.

OBsolete: TI has discontinued the production of the device.

(2) Eco Plan - The planned eco-friendly classification: Pb-Free (RoHS), Pb-Free (RoHS Exempt), or Green (RoHS & no Sb/Br) - please check <http://www.ti.com/productcontent> for the latest availability information and additional product content details.

TBD: The Pb-Free/Green conversion plan has not been defined.

Pb-Free (RoHS): TI's terms "Lead-Free" or "Pb-Free" mean semiconductor products that are compatible with the current RoHS requirements for all 6 substances, including the requirement that lead not exceed 0.1% by weight in homogeneous materials. Where designed to be soldered at high temperatures, TI Pb-Free products are suitable for use in specified lead-free processes.

Pb-Free (RoHS Exempt): This component has a RoHS exemption for either 1) lead-based flip-chip solder bumps used between the die and package, or 2) lead-based die adhesive used between the die and leadframe. The component is otherwise considered Pb-Free (RoHS compatible) as defined above.

Green (RoHS & no Sb/Br): TI defines "Green" to mean Pb-Free (RoHS compatible), and free of Bromine (Br) and Antimony (Sb) based flame retardants (Br or Sb do not exceed 0.1% by weight in homogeneous material)

(3) MSL, Peak Temp. - The Moisture Sensitivity Level rating according to the JEDEC industry standard classifications, and peak solder temperature.

(4) There may be additional marking, which relates to the logo, the lot trace code information, or the environmental category on the device.

(5) Multiple Device Markings will be inside parentheses. Only one Device Marking contained in parentheses and separated by a "~" will appear on a device. If a line is indented then it is a continuation of the previous line and the two combined represent the entire Device Marking for that device.

(6) Lead/Ball Finish - Orderable Devices may have multiple material finish options. Finish options are separated by a vertical ruled line. Lead/Ball Finish values may wrap to two lines if the finish value exceeds the maximum column width.

Important Information and Disclaimer: The information provided on this page represents TI's knowledge and belief as of the date that it is provided. TI bases its knowledge and belief on information provided by third parties, and makes no representation or warranty as to the accuracy of such information. Efforts are underway to better integrate information from third parties. TI has taken and continues to take reasonable steps to provide representative and accurate information but may not have conducted destructive testing or chemical analysis on incoming materials and chemicals. TI and TI suppliers consider certain information to be proprietary, and thus CAS numbers and other limited information may not be available for release.

In no event shall TI's liability arising out of such information exceed the total purchase price of the TI part(s) at issue in this document sold by TI to Customer on an annual basis.

ZAY0196A

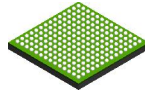

PACKAGE OUTLINE

NFBGA - 1.4 mm max height

PLASTIC BALL GRID ARRAY

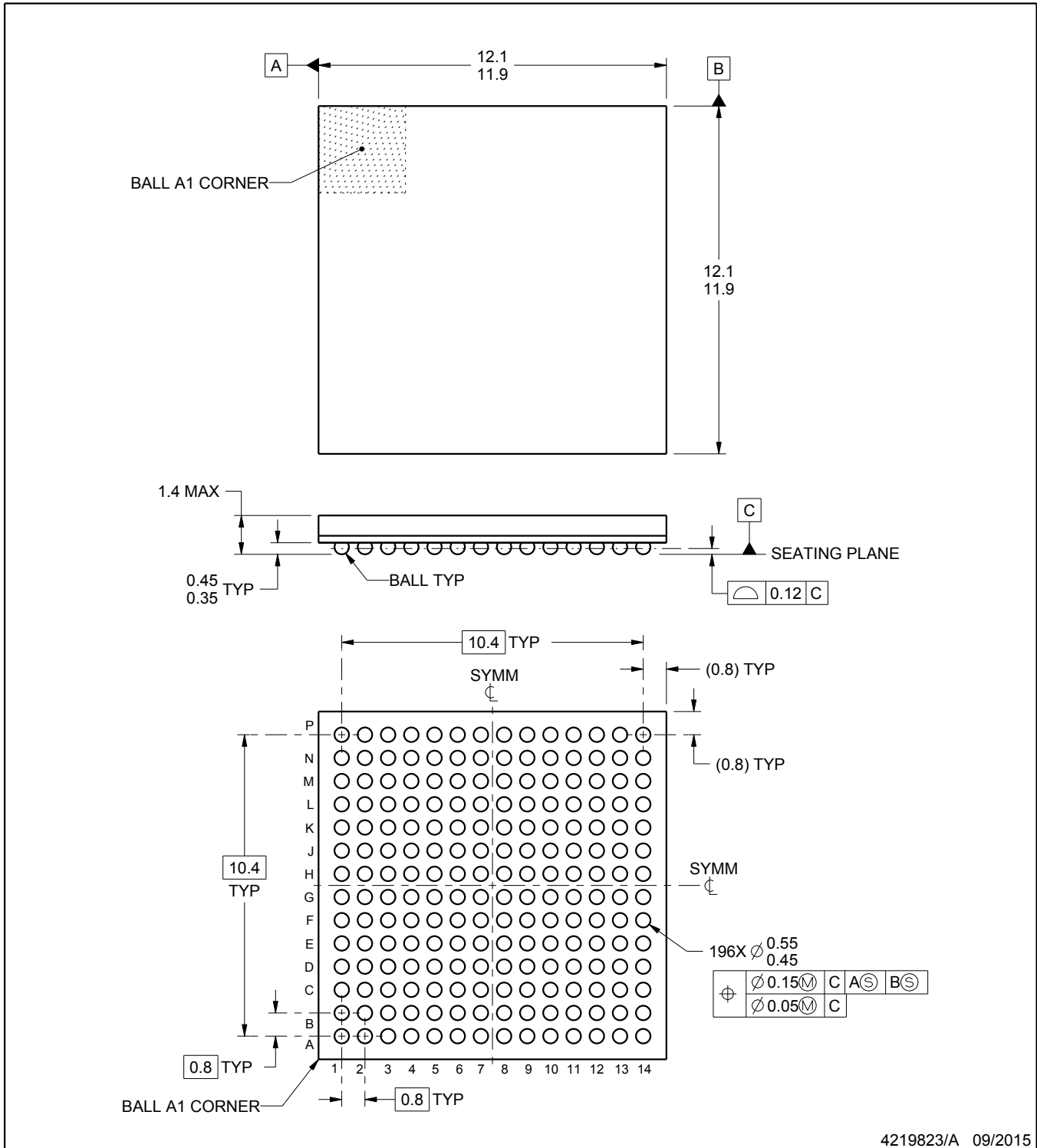

NOTES:

1. All linear dimensions are in millimeters. Any dimensions in parenthesis are for reference only. Dimensioning and tolerancing per ASME Y14.5M.
2. This drawing is subject to change without notice.

EXAMPLE BOARD LAYOUT

ZAY0196A

NFBGA - 1.4 mm max height

PLASTIC BALL GRID ARRAY

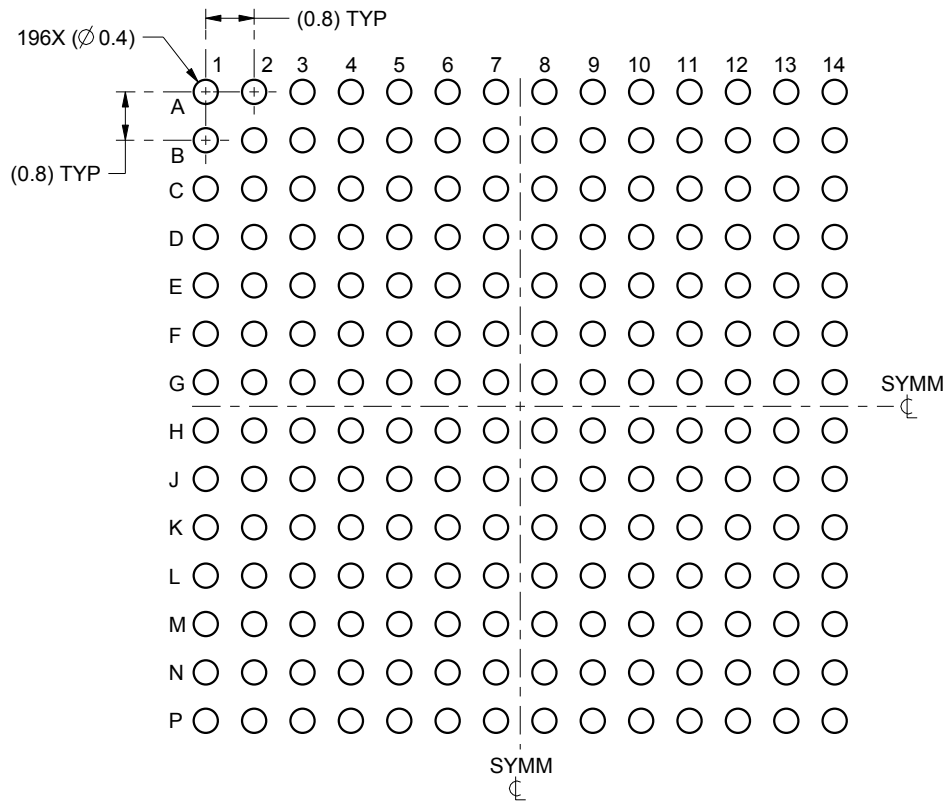

LAND PATTERN EXAMPLE
SCALE:8X

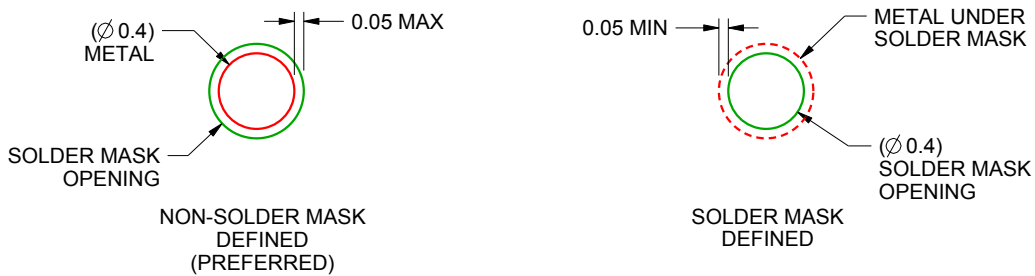

SOLDER MASK DETAILS
NOT TO SCALE

4219823/A 09/2015

NOTES: (continued)

- Final dimensions may vary due to manufacturing tolerance considerations and also routing constraints. For information, see Texas Instruments literature number SPRAA99 (www.ti.com/lit/spraa99).

EXAMPLE STENCIL DESIGN

ZAY0196A

NFBGA - 1.4 mm max height

PLASTIC BALL GRID ARRAY

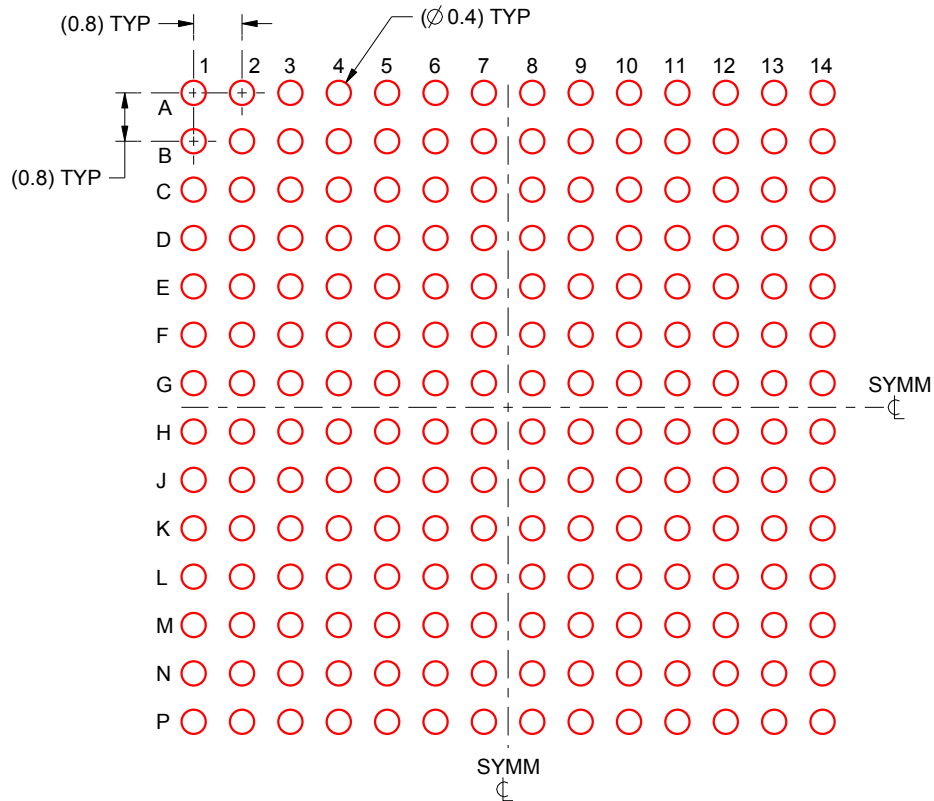

SOLDER PASTE EXAMPLE
BASED ON 0.15 mm THICK STENCIL
SCALE:8X

4219823/A 09/2015

NOTES: (continued)

4. Laser cutting apertures with trapezoidal walls and rounded corners may offer better paste release.

IMPORTANT NOTICE AND DISCLAIMER

TI PROVIDES TECHNICAL AND RELIABILITY DATA (INCLUDING DATASHEETS), DESIGN RESOURCES (INCLUDING REFERENCE DESIGNS), APPLICATION OR OTHER DESIGN ADVICE, WEB TOOLS, SAFETY INFORMATION, AND OTHER RESOURCES "AS IS" AND WITH ALL FAULTS, AND DISCLAIMS ALL WARRANTIES, EXPRESS AND IMPLIED, INCLUDING WITHOUT LIMITATION ANY IMPLIED WARRANTIES OF MERCHANTABILITY, FITNESS FOR A PARTICULAR PURPOSE OR NON-INFRINGEMENT OF THIRD PARTY INTELLECTUAL PROPERTY RIGHTS.

These resources are intended for skilled developers designing with TI products. You are solely responsible for (1) selecting the appropriate TI products for your application, (2) designing, validating and testing your application, and (3) ensuring your application meets applicable standards, and any other safety, security, or other requirements. These resources are subject to change without notice. TI grants you permission to use these resources only for development of an application that uses the TI products described in the resource. Other reproduction and display of these resources is prohibited. No license is granted to any other TI intellectual property right or to any third party intellectual property right. TI disclaims responsibility for, and you will fully indemnify TI and its representatives against, any claims, damages, costs, losses, and liabilities arising out of your use of these resources.

TI's products are provided subject to TI's Terms of Sale (www.ti.com/legal/termsofsale.html) or other applicable terms available either on ti.com or provided in conjunction with such TI products. TI's provision of these resources does not expand or otherwise alter TI's applicable warranties or warranty disclaimers for TI products.

Mailing Address: Texas Instruments, Post Office Box 655303, Dallas, Texas 75265
Copyright © 2019, Texas Instruments Incorporated

Looking for pricing, stock, or lifecycle information?

Click below to explore more details on WIN SOURCE:

 [View DAC34SH84IZAYR on WIN SOURCE](#)

 [Texas Instruments](#) Information

Optimize Your Supply Chain with WIN SOURCE Solutions

-  Global Sourcing Solution
-  Obsolete Management
-  Cost Control Management
-  Shortage Management
-  Alternative Solution
-  Excess Inventory Management