





# High-Efficiency Step-Up Current Regulator for LEDs

## General Description

The MAX1698 and MAX1698A are efficient drivers for white or color LEDs. They are ideal for large LED backlight displays in PDAs and laptop computers. Numerous benefits include greater simplicity, lower cost, higher efficiency, longer bulb life, and greater reliability when compared to fluorescent (CCFL) and electroluminescent (EL) lamps.

The MAX1698/MAX1698A are switch-mode boost controllers in which LED current, rather than output voltage, is regulated. The devices drive series-connected LEDs with a controlled current that is measured with a typical 15Ω sense resistor, not an expensive fractional-ohm value. LED current control and dimming are accomplished with an adjust input (ADJ). For larger light output, multiple LED banks can be connected in parallel with up to 5W total output power.

The MAX1698A has a higher, and more accurately specified, CS current limit than the MAX1698 for higher-power applications of 5W or more. Both devices are supplied in a space-saving 10-pin μMAX package that occupies half the space of an 8-pin SO. An evaluation kit (MAX1698EVKIT) is available to speed designs.

## Applications

Battery-Powered Backlight Applications  
Backlight for LCD Panels  
Notebook PCs  
Handy Terminals  
PDAs

## Features

- ◆ Over 90% Efficiency
- ◆ Lossless, Adjustable LED Brightness
- ◆ Space-Saving 10-Pin μMAX Package
- ◆ Simpler, Lower Cost, More Reliable Compared to CCFL or EL Backlights
- ◆ Up to 5W Output Power

## Ordering Information

PART	TEMP RANGE	PIN-PACKAGE	PKG CODE
MAX1698EUB	-40°C to +85°C	10μMAX	U10-2
MAX1698AEUB	-40°C to +85°C	10μMAX	U10-2

## Pin Configuration

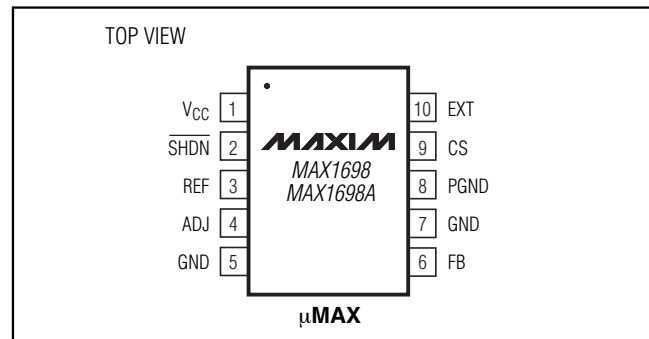

## Typical Operating Circuit

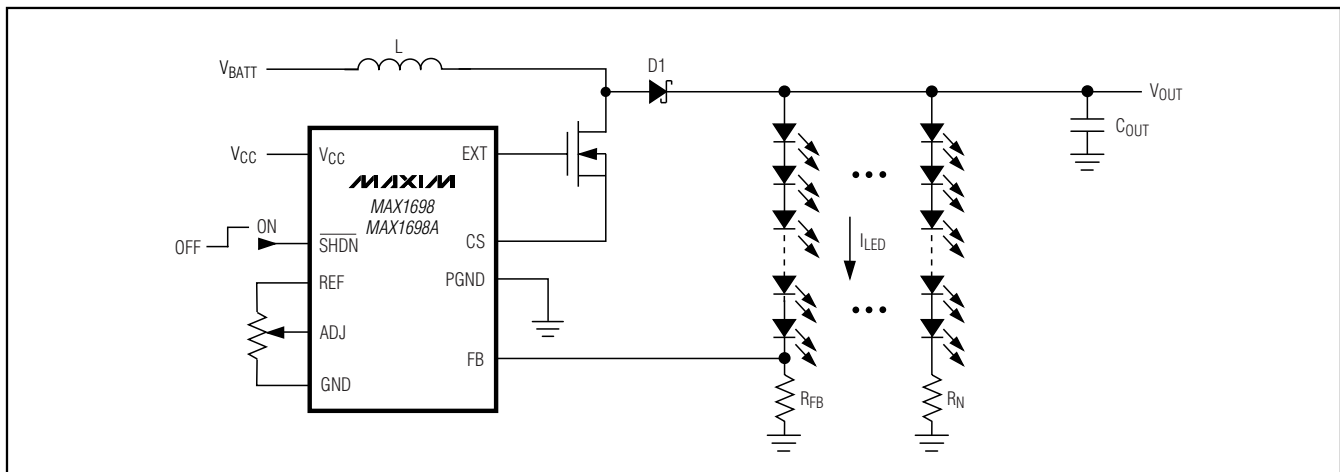

# High-Efficiency Step-Up Current Regulator for LEDs

## ABSOLUTE MAXIMUM RATINGS

V<sub>CC</sub>,  $\overline{\text{SHDN}}$  to GND .....-0.3V to +6V  
 EXT, FB, CS, ADJ, REF to GND.....-0.3V to (V<sub>CC</sub> + 0.3V)  
 GND to PGND .....±0.3V  
 Continuous Power Dissipation (T<sub>A</sub> = +70°C)  
 10-Pin  $\mu$ MAX (derate 5.6mW/°C above +70°C) .....444mW

Operating Temperature Range .....-40°C to +85°C  
 Junction Temperature .....+150°C  
 Storage Temperature Range .....-65°C to +150°C  
 Lead Temperature Range (soldering, 10s).....+300°C

Stresses beyond those listed under "Absolute Maximum Ratings" may cause permanent damage to the device. These are stress ratings only, and functional operation of the device at these or any other conditions beyond those indicated in the operational sections of the specifications is not implied. Exposure to absolute maximum rating conditions for extended periods may affect device reliability.

## ELECTRICAL CHARACTERISTICS

(V<sub>CC</sub> = +3.3V, T<sub>A</sub> = 0°C to +85°C, unless otherwise noted. Typical values are at T<sub>A</sub> = +25°C.)

PARAMETER	SYMBOL	CONDITIONS	MIN	TYP	MAX	UNITS	
Supply Voltage	V <sub>CC</sub>		2.7		5.5	V	
Quiescent Supply Current	I <sub>CC</sub>	V <sub>FB</sub> = 0.3V		260	500	μA	
Undervoltage Lockout		Rising edge	2.25	2.4	2.55	V	
Undervoltage Hysteresis				80		mV	
FB Regulation Voltage	V <sub>FB</sub>	ADJ = REF	285	300	315	mV	
		V <sub>ADJ</sub> = 100mV	18	24	30		
CS Trip Current		FB = GND	MAX1698A	2.0	2.4	2.8	A
			MAX1698	0.8	1.5	2.5	
CS Input Current	I <sub>CS</sub>				0.8	A <sub>RMS</sub>	
Minimum Off Time	t <sub>OFF(MIN)</sub>	FB = GND, ADJ = REF	0.8	1.0	1.2	μs	
Maximum On Time	t <sub>ON(MAX)</sub>	FB = GND, ADJ = REF, CS = GND	10	15	20	μs	
ADJ Start Threshold			30	50	70	mV	
ADJ Input Range	V <sub>ADJ</sub>		0.03		REF	V	
FB Input Bias Current	I <sub>FB</sub>	V <sub>FB</sub> = 300mV	-15		15	nA	
ADJ Input Bias Current	I <sub>ADJ</sub>	ADJ = REF	-50		50	nA	
Shutdown Supply Current		$\overline{\text{SHDN}}$ = GND		0.01	1	μA	
REF Output Voltage	V <sub>REF</sub>	I <sub>REF</sub> = 0	1.20	1.25	1.30	V	
REF Load Regulation	ΔV <sub>REF</sub>	I <sub>REF</sub> = 0 to 150μA		-2	-25	mV	
REF Short-Circuit Current		REF = GND		0.45	1	mA	
REF Power-Supply Rejection Ratio	PSRR	V <sub>CC</sub> = 2.7V to 5.5V		+0.3	+2	mV/V	
EXT Driver Sink/Source Current		V <sub>CC</sub> = 5V, EXT = 2V		0.2		A	
EXT Driver On-Resistance		V <sub>CC</sub> = 5V			8	Ω	
$\overline{\text{SHDN}}$ Input High Voltage	V <sub>IH</sub>	V <sub>CC</sub> = 2.7V to 5.5V	2			V	
$\overline{\text{SHDN}}$ Input Low Voltage	V <sub>IL</sub>	V <sub>CC</sub> = 2.7V to 5.5V			0.8	V	
$\overline{\text{SHDN}}$ Input Bias Current	I <sub>SHDN</sub>	V <sub>CC</sub> = 2.7V to 5.5V	-1		1	μA	

# High-Efficiency Step-Up Current Regulator for LEDs

MAX1698/MAX1698A

## ELECTRICAL CHARACTERISTICS

( $V_{CC} = +3.3V$ ,  $T_A = -40^{\circ}C$  to  $+85^{\circ}C$ , unless otherwise noted.) (Note 1)

PARAMETER	SYMBOL	CONDITIONS	MIN	MAX	UNITS	
Supply Voltage	$V_{CC}$		2.7	5.5	V	
Quiescent Supply Current	$I_{CC}$	$V_{FB} = 0.3V$		500	$\mu A$	
Undervoltage Lockout		Rising edge	2.20	2.65	V	
FB Regulation Voltage	$V_{FB}$	ADJ = REF	280	320	mV	
		$V_{ADJ} = 100mV$	13	35		
CS Trip Current		FB = GND	MAX1698A	2.0	3.0	A
			MAX1698	0.8	3.0	
Minimum Off Time	$t_{OFF(MIN)}$	FB = GND, ADJ = REF	0.6	1.4	$\mu s$	
Maximum On Time	$t_{ON(MAX)}$	FB = GND, ADJ = REF, CS = GND	9	21	$\mu s$	
ADJ Start Threshold			25	75	mV	
FB Input Bias Current	$I_{FB}$	$V_{FB} = 300mV$	-20	20	nA	
ADJ Input Bias Current	$I_{ADJ}$	ADJ = REF	-50	50	nA	
Shutdown Supply Current		$\overline{SHDN} = GND$		1	$\mu A$	
REF Output Voltage	$V_{REF}$	$I_{REF} = 0$	1.17	1.33	V	
REF Load Regulation	$\Delta V_{REF}$	$I_{REF} = 0$ to $150\mu A$		-30	mV	
REF Short-Circuit Current		REF = GND		1	mA	
REF Power-Supply Rejection Ratio	PSRR	$V_{CC} = 2.7V$ to $5.5V$		+2	mV/V	
EXT On-Resistance		$V_{CC} = 5V$		8	$\Omega$	
$\overline{SHDN}$ Input High Voltage	$V_{IH}$	$V_{CC} = 2.7V$ to $5.5V$	2		V	
$\overline{SHDN}$ Input Low Voltage	$V_{IL}$	$V_{CC} = 2.7V$ to $5.5V$		0.8	V	
$\overline{SHDN}$ Input Bias Current	$I_{\overline{SHDN}}$	$V_{CC} = 2.7V$ to $5.5V$	-1	1	$\mu A$	

**Note 1:** Specifications to  $-40^{\circ}C$  are guaranteed by design, not production tested.

# High-Efficiency Step-Up Current Regulator for LEDs

## Typical Operating Characteristics

(Circuit of Figure 2,  $V_{CC} = V_{BATT} = 3.3V$ ,  $V_{ADJ} = V_{REF}$ ,  $T_A = +25^\circ C$ , unless otherwise noted.)

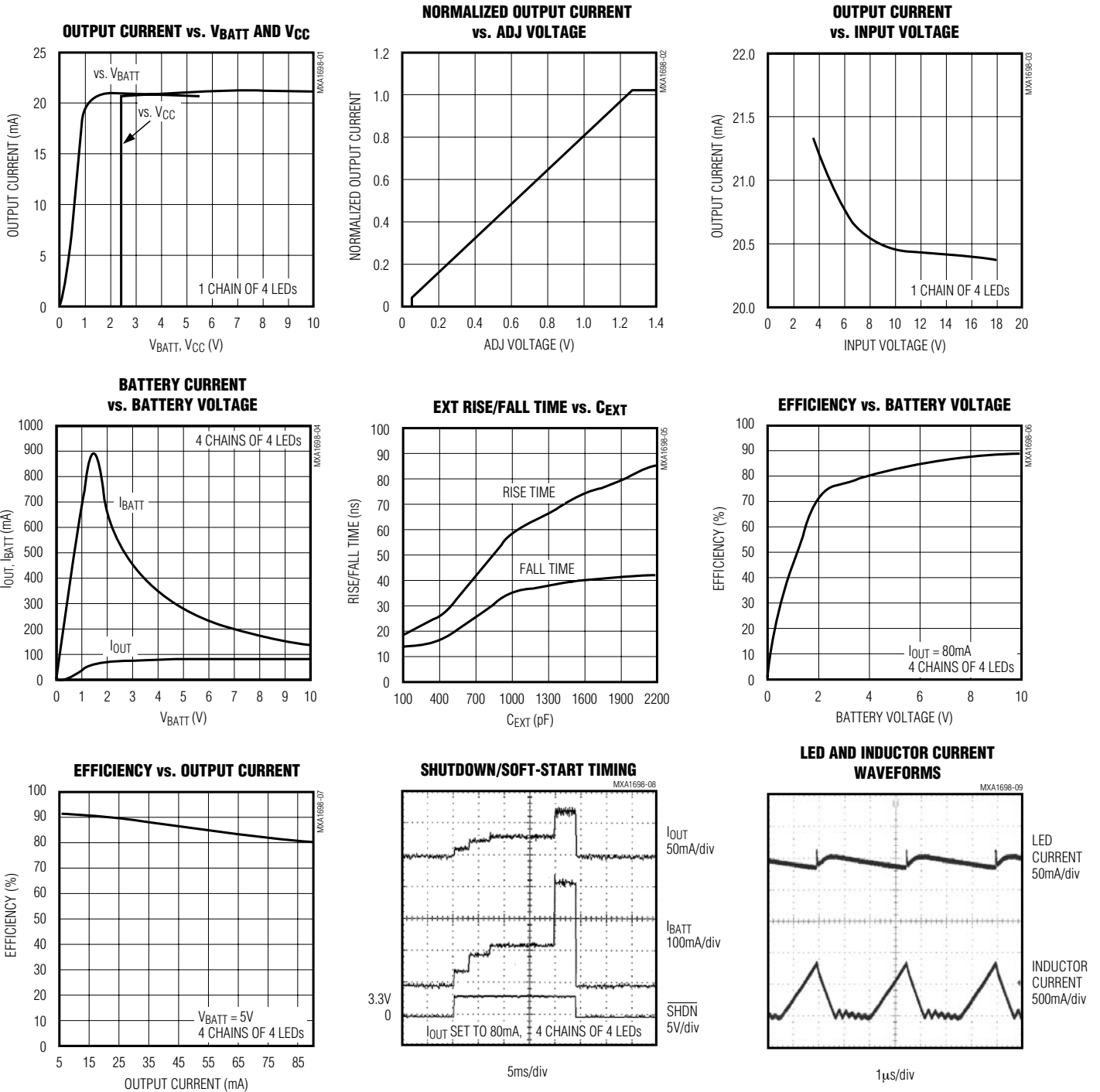

# High-Efficiency Step-Up Current Regulator for LEDs

## Pin Description

MAX1698/MAX1698A

PIN	NAME	FUNCTION
1	V <sub>CC</sub>	IC Supply Voltage Input. Power for internal circuitry. Input range is 2.7V to 5.5V.
2	$\overline{\text{SHDN}}$	Active-Low Shutdown Input. In shutdown, the MOSFET turns off, but a current path still exists between the input and output. The minimum forward voltage of the LED array must exceed the maximum V <sub>BATT</sub> to ensure that the LEDs are off in shutdown.
3	REF	1.25V Reference Output. Capable of sourcing 150 $\mu$ A for external loads. This pin is internally compensated. Do not connect any bypass capacitors at REF.
4	ADJ	Adjust Input. Allows dynamic adjustment of the output current. FB regulates to 300mV when ADJ = REF.
5, 7	GND	Ground
6	FB	Feedback Input. Connect to the external LED current-sense feedback resistor.
8	PGND	Power Ground
9	CS	FET Current-Sense Input
10	EXT	Gate Driver Output

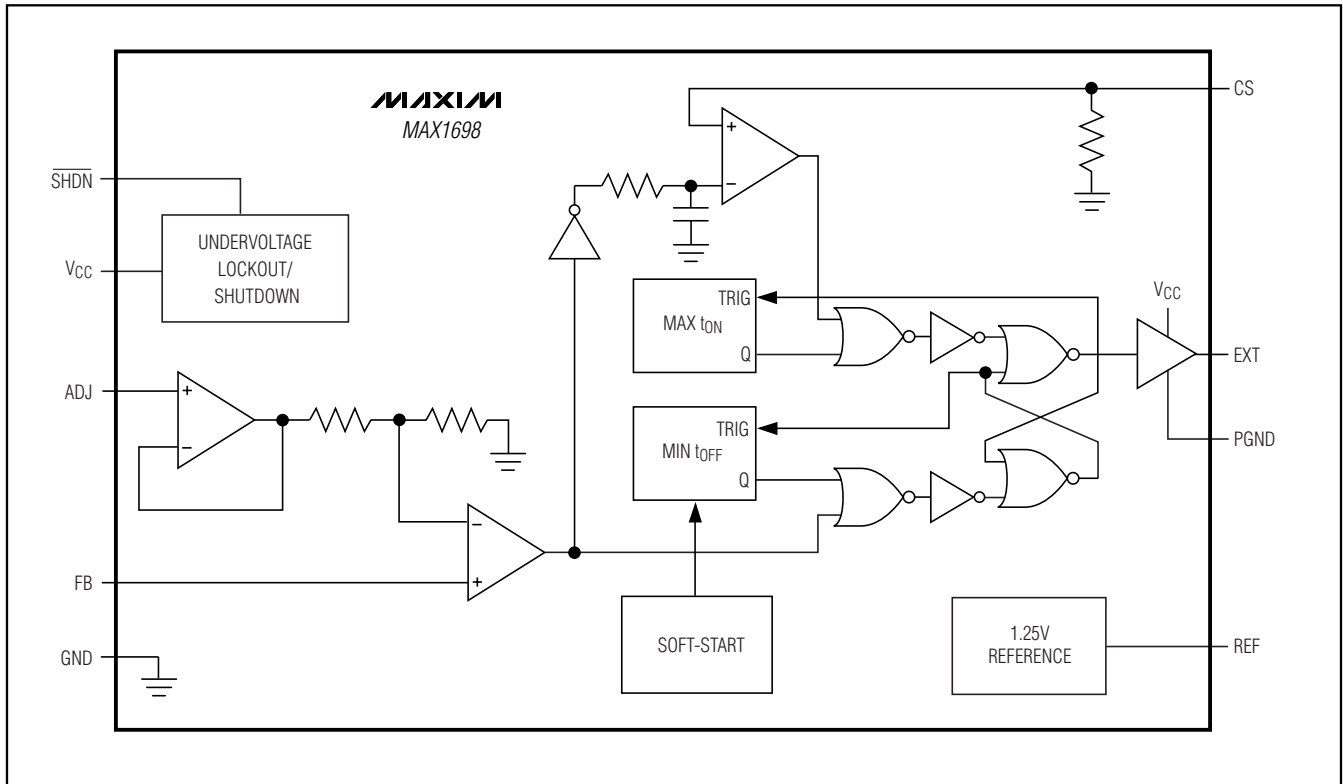

Figure 1. Functional Diagram

# High-Efficiency Step-Up Current Regulator for LEDs

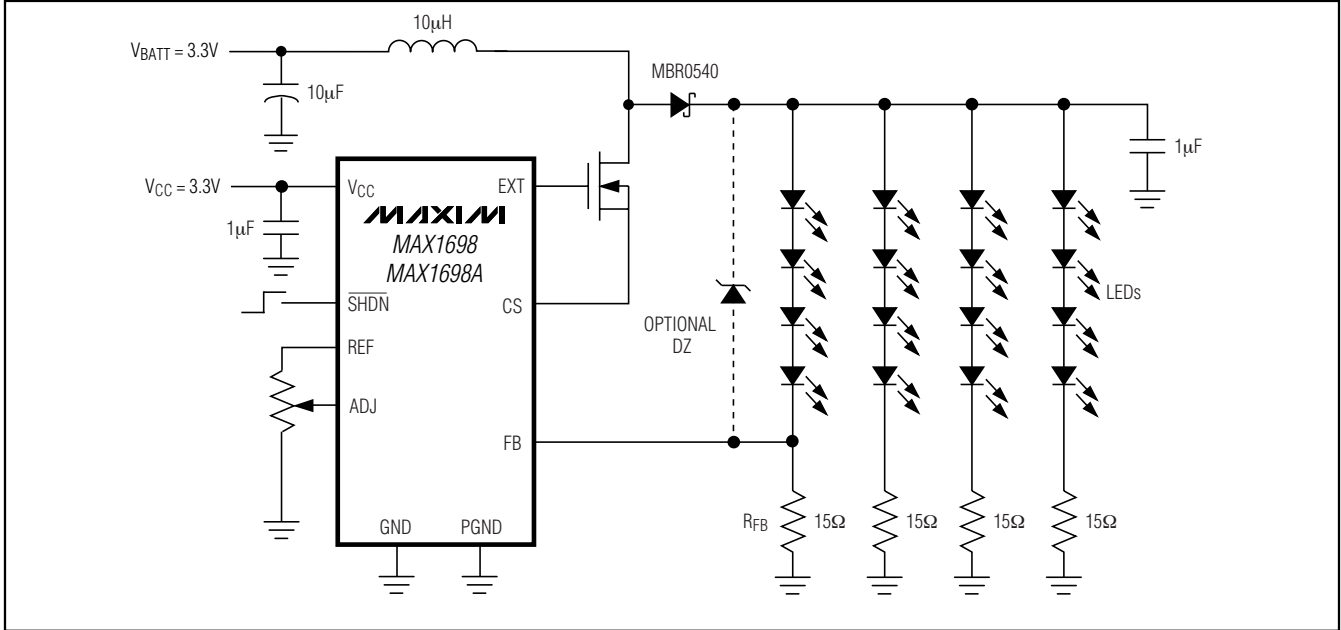

Figure 2. Typical Operating Circuit

## Detailed Description

The MAX1698/MAX1698As' high efficiency and small size make them ideally suited to drive LEDs. They operate as a boost DC-DC converter that controls output current rather than voltage. Losses are minimized by a low, 300mV current-sense threshold. In the standard configuration, a feedback resistor,  $R_{FB}$ , sets the current through the primary chain of LEDs. Additional chains of matching LEDs can be added with an equivalent resistor. In matched LED arrays, the secondary chain currents closely track the primary chain. An optional zener diode, D2, prevents overvoltage in the event that one of the LEDs in the primary chain becomes an open circuit. The LED brightness can be adjusted dynamically by a voltage input at ADJ.

### Shutdown

In shutdown, the supply current is reduced below 1µA. EXT goes low in shutdown, shutting off the external N-channel FET. This leaves a current path between the input and the LEDs through the boost inductor and catch diode. The minimum forward voltage of the LED array must exceed the maximum  $V_{BATT}$  to ensure that the LEDs remain off in shutdown. Typical shutdown timing characteristics are shown in the *Typical Operating Characteristics*.

### Soft-Start

The MAX1698/MAX1698A include a soft-start function that eliminates input current surges at turn-on. They do this by extending the external FET driver (EXT) minimum off-time during start-up. During the first 512 switching cycles, the minimum off-time is 5µs. It is then allowed to drop to 2µs for the next 1500 switching cycles. After that time, the minimum off-time falls to the 1µs value used during normal operation. (See Shutdown/Soft-Start Timing in the *Typical Operating Characteristics* section.)

## Design Procedure

### Setting the Maximum LED Current

Resistor  $R_{FB}$  sets the maximum current in the primary chain of LEDs:

$$R_{FB} = \frac{300\text{mV}}{I_{LED\text{MAX}}}$$

where  $I_{LED\text{MAX}}$  is the maximum LED current.

### Adjusting LED Current

$R_{FB}$  sets the maximum LED current. This current can be reduced proportional to the voltage at the ADJ pin (see Normalized Output Current vs. ADJ Voltage in the *Typical Operating Characteristics* section). Figure 3

# High-Efficiency Step-Up Current Regulator for LEDs

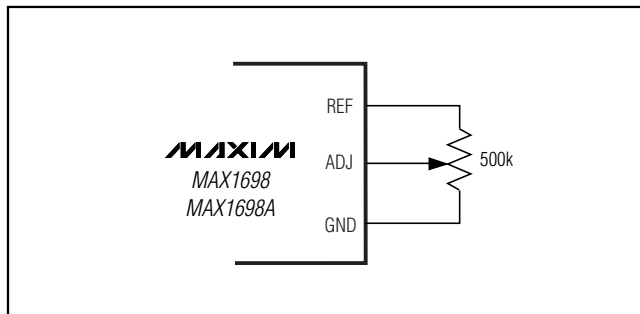

Figure 3. Adjusting LED Current

shows the standard method of setting the ADJ voltage. Use the following equation to determine  $I_{LED}$ :

$$I_{LED} = \frac{V_{ADJ}}{4.16 \cdot R_{FB}}$$

where  $V_{ADJ}$  is the voltage at ADJ. Note that ADJ voltages below 50mV turn the LEDs off.

### Inductor Selection

Choose an inductor with low DC resistance (in the neighborhood of 100mΩ) to minimize losses. A typical inductance value for L is 10μH; however, values from 3.3μH to 100μH can also be used. Higher inductor values reduce the MAX1698's switching frequency. The typical operating frequency is given by:

$$f = \frac{0.67 \cdot V_{BATT}}{L}$$

The MAX1698/MAX1698A limit peak inductor current to 1.5A, but also contains a control loop that reduces inductor current as a function of output power. For a given output power, the required inductor peak current rating is approximately set by:

$$I_{L(PEAK)} = 1.0 \cdot P_{OUT}$$

where  $P_{OUT}$  is the output power to all LED banks in watts and  $I_{L(PEAK)}$  is in amperes.

### Capacitor Selection

The exact value of output capacitance is not critical. Typical values for the output capacitor are 0.1μF to 10μF. Larger values help reduce output ripple at the expense of size and higher cost.

The requirements of the input capacitor depend on the type of the input voltage source. However, in many applications, the same capacitor type and value are used for both the input and output capacitors.

### Transistor Selection

The MAX1698/MAX1698A drive an external N-channel MOSFET. Since the gate drive voltage is derived from  $V_{CC}$ , best performance is achieved with low-threshold NFETs that specify on-resistance with gate-source voltages ( $V_{GS}$ ) at the voltage supplied at  $V_{CC}$  or less. For best results, minimize the FET's  $R_{DS(ON)}$ . The external NFET's maximum drain-to-source voltage ( $V_{DS(MAX)}$ ) must exceed the output voltage.

### Catch Diode (D1) Selection

The MAX1698/MAX1698As' high-switching frequency demands a high-speed rectifier. Schottky diodes are recommended for most applications, due to their fast recovery time and low forward-voltage drop. Ensure that the diode's average and peak current ratings exceed the average output current and peak inductor current, respectively. In addition, the diode's reverse breakdown voltage must exceed  $V_{OUT}$ . For output voltages exceeding 40V, high-speed silicon rectifiers may be required for their higher breakdown voltages.

### Zener Diode

For applications requiring open-circuit protection if one of the LEDs in the primary chain opens, add a zener diode as shown in Figure 2. The zener diode protects the MOSFET and output capacitor if the current feedback signal is lost. The zener voltage should exceed the maximum forward voltage of the LED network by at least 2V.

## Applications Information

### PCB Layout

Due to fast switching waveforms and high-current paths, careful PCB layout is required. Protoboards and wire-wrap boards should not be used for evaluation. An EV kit (MAX1698EVKIT) is available to aid most designs.

When laying out a board, minimize trace lengths to CS, the inductor, diode, input capacitor, and output capacitor. Keep traces short, direct, and wide. Keep noisy traces, such as the inductor's traces, away from FB.  $V_{CC}$ 's bypass capacitor should be placed as close to the IC as possible.

Refer to the MAX1698 EV kit for an example of proper layout.

## Chip Information

TRANSISTOR COUNT: 2180

# High-Efficiency Step-Up Current Regulator for LEDs

## Package Information

(The package drawing(s) in this data sheet may not reflect the most current specifications. For the latest package outline information go to [www.maxim-ic.com/packages](http://www.maxim-ic.com/packages).)

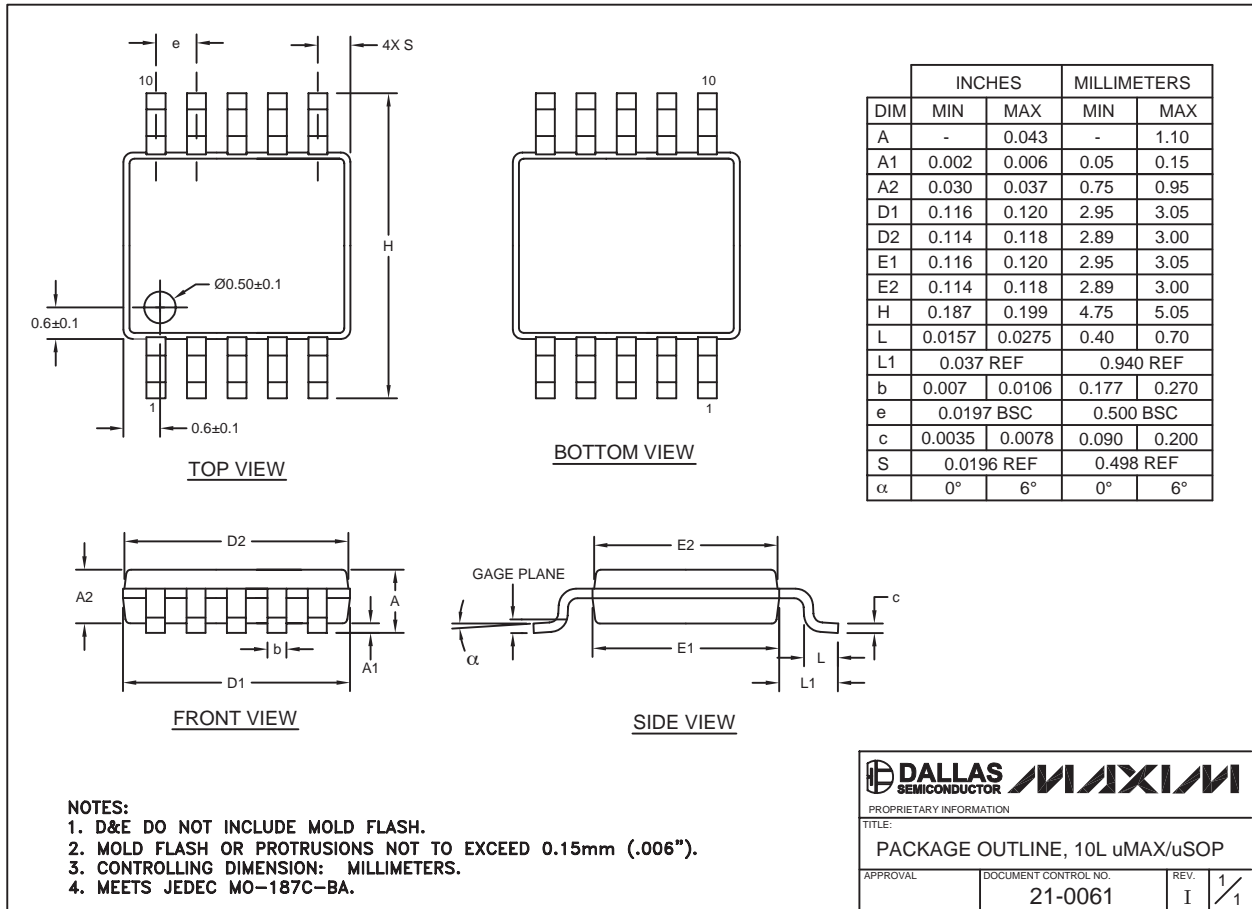

10LUMAXEPS

**Note:** The MAX1698 does not have an exposed pad.

## Revision History

Pages changed at Rev 2: 1, 2, 8

Maxim cannot assume responsibility for use of any circuitry other than circuitry entirely embodied in a Maxim product. No circuit patent licenses are implied. Maxim reserves the right to change the circuitry and specifications without notice at any time.

8 Maxim Integrated Products, 120 San Gabriel Drive, Sunnyvale, CA 94086 408-737-7600

## Looking for pricing, stock, or lifecycle information?

Click below to explore more details on WIN SOURCE:

- ⊖ [View MAX1698AEUB+T on WIN SOURCE](#)
- ⊖ [Maxim Integrated Information](#)

## Optimize Your Supply Chain with WIN SOURCE Solutions

- ✓ Global Sourcing Solution
- ✓ Obsolete Management
- ✓ Cost Control Management
- ✓ Shortage Management
- ✓ Alternative Solution
- ✓ Excess Inventory Management