



**THE DATASHEET OF
UC3611N**



QUAD SCHOTTKY DIODE ARRAY

FEATURES

- Matched, Four-Diode Monolithic Array
- High Peak Current
- Low-Cost MINIDIP Package
- Low-Forward Voltage
- Parallelable for Lower V_F or Higher I_F
- Fast Recovery Time
- Military Temperature Range Available

DESCRIPTION

This four-diode array is designed for general purpose use as individual diodes or as a high-speed, high-current bridge. It is particularly useful on the outputs of high-speed power MOSFET drivers where Schottky diodes are needed to clamp any negative excursions caused by ringing on the driven line. These diodes are also ideally suited for use as voltage clamps when driving inductive loads such as relays and solenoids, and to provide a path for current free-wheeling in motor drive applications. The use of Schottky diode technology features high efficiency through lowered forward voltage drop and decreased reverse recovery time. This single monolithic chip is fabricated in both hermetic CERDIP and copper-eated plastic packages. The UC1611 in ceramic is designed for -55°C to 125°C environments but with reduced peak current capability; while the UC3611 in plastic has higher current rating over a 0°C to 70°C ambient temperature range.

AVAILABLE OPTIONS

$T_A = T_J$	Packaged Devices		
	SOIC Wide (DW)	DIL (J)	DIL (N)
-55°C to 125°C	UC1611DW	UC1611J	UC1611N
0°C to 70°C	UC3611DW	UC3611J	UC3611N

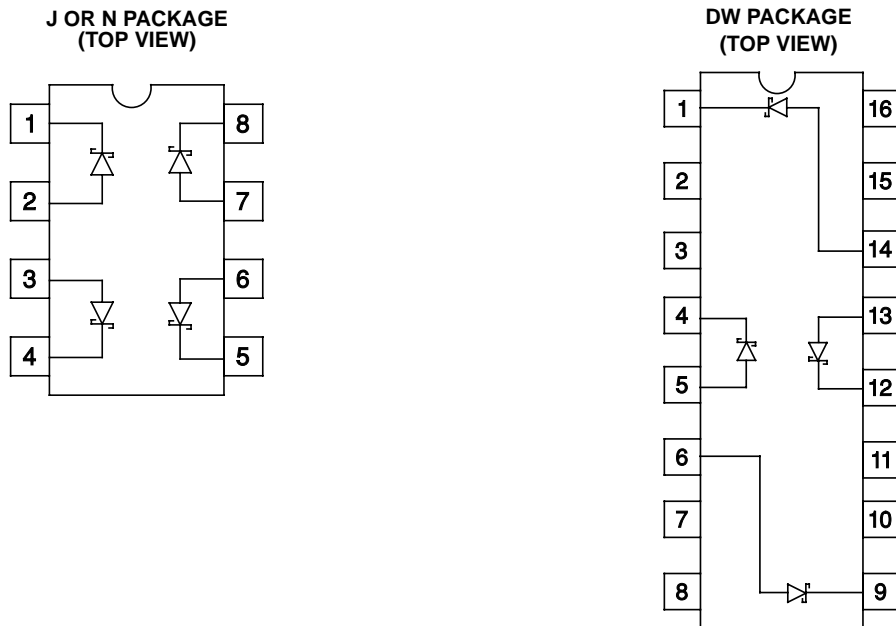

absolute maximum ratings over operating free-air temperature (unless otherwise noted)†

Peak inverse voltage (per diode)	50 V
Diode-to-diode voltage	80 V
Peak forward current	
UC1611	1 A
UC3611	3 A
Power dissipation at $T_A = 70^\circ\text{C}$	1 W
Storage temperature range, T_{stg}	-65°C to 150°C
Lead temperature (soldering, 10 seconds)	300°C

† Stresses beyond those listed under “absolute maximum ratings” may cause permanent damage to the device. These are stress ratings only, and functional operation of the device at these or any other conditions beyond those indicated under “recommended operating conditions” is not implied. Exposure to absolute-maximum-rated conditions for extended periods may affect device reliability.

‡ Please consult packaging section of data book for thermal limitations and considerations of package.

electrical characteristics, all specifications apply to each individual diode, $T_J = 25^\circ\text{C}$, $T_A = T_J$, (except as noted)

PARAMETER	TEST CONDITIONS	MIN	TYP	MAX	UNITS
Forward voltage drop	$I_F = 100\text{ mA}$	0.3	0.4	0.7	V
	$I_F = 1\text{ A}$		0.9	1.2	V
Leakage current	$V_R = 40\text{ V}$		0.01	0.1	mA
	$V_R = 40\text{ V}$, $T_J = 100^\circ\text{C}$		0.1	1.0	mA
Reverse recovery	0.5 A forward to 0.5 A reverse		20		ns
Forward recovery	1 A forward to 1.1 V recovery		40		ns
Junction capacitance	$V_R = 5\text{ V}$		100		pF

NOTE: At forward currents of greater than 1.0 A, a parasitic current of approximately 10 mA may be collected by adjacent diodes.

APPLICATION INFORMATION

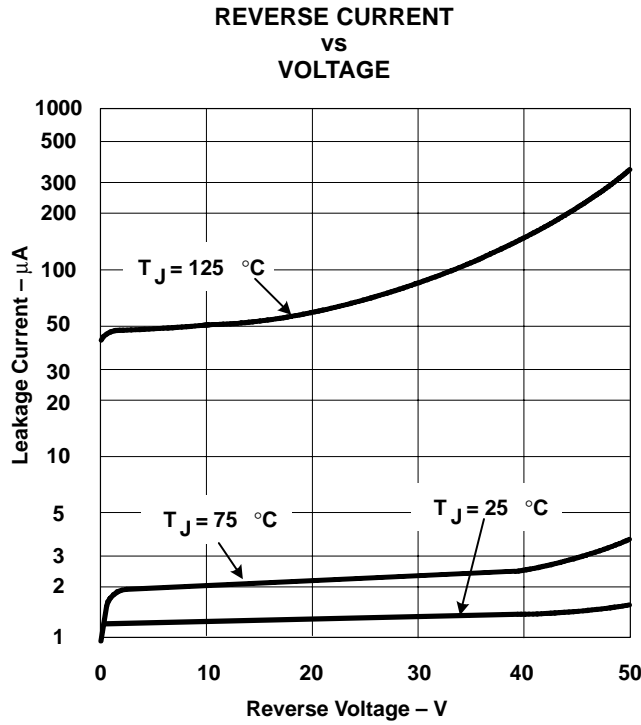

Figure 1

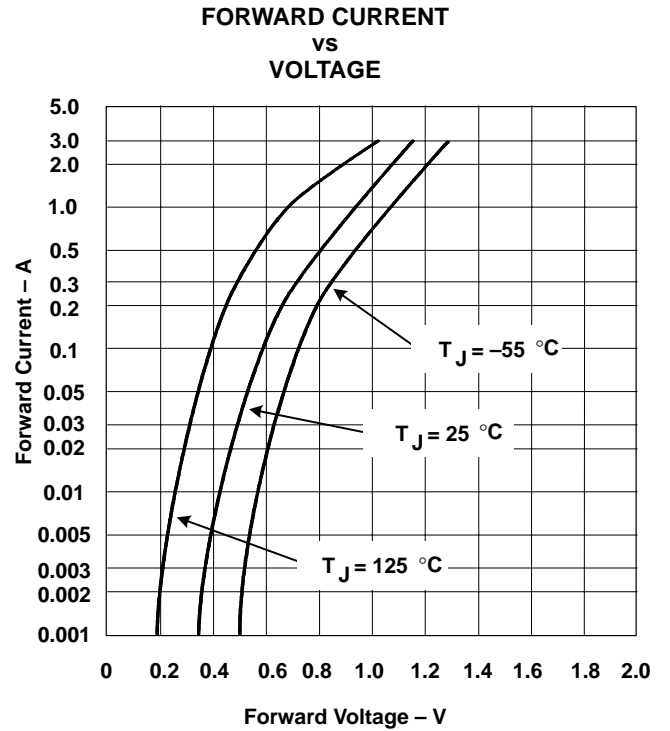

Figure 2

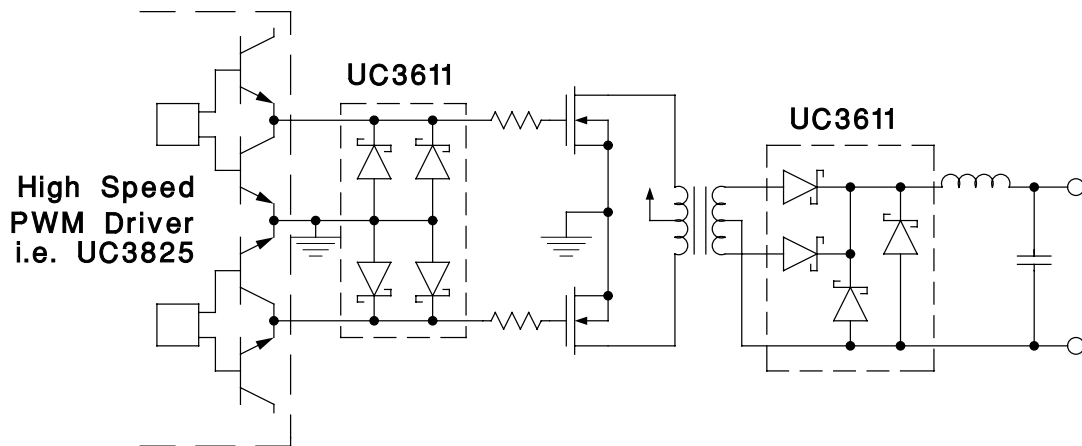

Figure 3. Clamp Diodes – PWMs and Drivers

APPLICATION INFORMATION

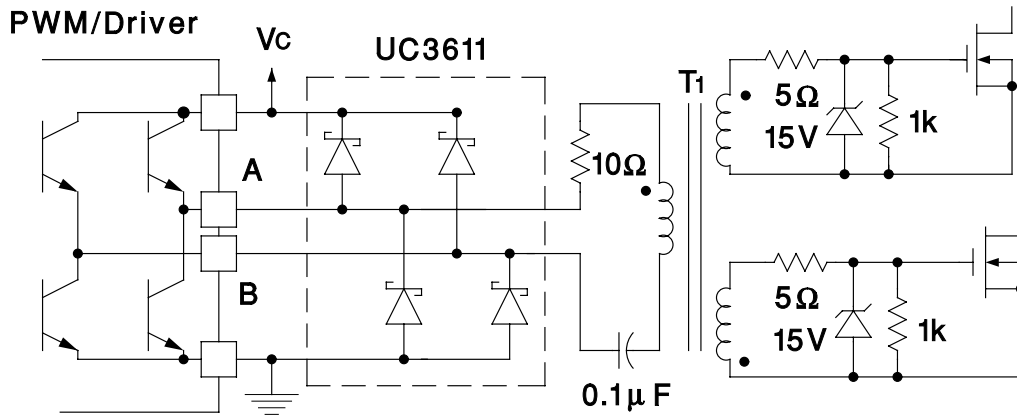

Figure 4. Transformer Coupled Drive Circuits

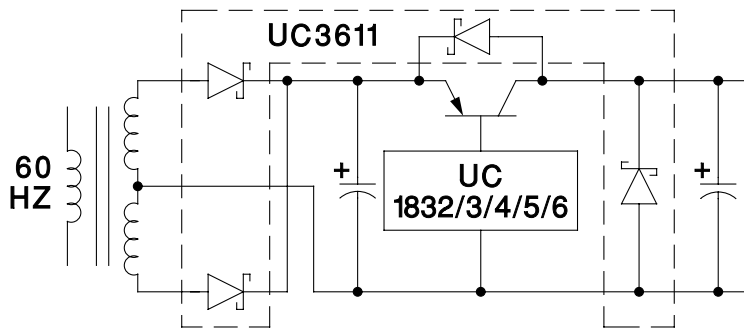

Figure 5. Linear Regulations

PACKAGING INFORMATION

Orderable Device	Status (1)	Package Type	Package Drawing	Pins	Package Qty	Eco Plan (2)	Lead/Ball Finish (6)	MSL Peak Temp (3)	Op Temp (°C)	Device Marking (4/5)	Samples
5962-90538012A	ACTIVE	LCCC	FK	20	1	TBD	POST-PLATE	N / A for Pkg Type	-55 to 125	5962-90538012A UC1611L/ 883B	Samples
5962-9053801PA	ACTIVE	CDIP	JG	8	1	TBD	A42	N / A for Pkg Type	-55 to 125	9053801PA UC1611	Samples
5962-9053801V2A	ACTIVE	LCCC	FK	20	1	TBD	POST-PLATE	N / A for Pkg Type	-55 to 125	5962-9053801V2A UC1611L QMLV	Samples
5962-9053801VPA	ACTIVE	CDIP	JG	8	1	TBD	A42	N / A for Pkg Type	-55 to 125	9053801VPA UC1611	Samples
UC1611J	ACTIVE	CDIP	JG	8	1	TBD	A42	N / A for Pkg Type	-55 to 125	UC1611J	Samples
UC1611J883B	ACTIVE	CDIP	JG	8	1	TBD	A42	N / A for Pkg Type	-55 to 125	9053801PA UC1611	Samples
UC1611L883B	ACTIVE	LCCC	FK	20	1	TBD	POST-PLATE	N / A for Pkg Type	-55 to 125	5962-90538012A UC1611L/ 883B	Samples
UC3611DW	ACTIVE	SOIC	DW	16	40	Green (RoHS & no Sb/Br)	CU NIPDAU	Level-2-260C-1 YEAR	0 to 70	UC3611DW	Samples
UC3611J	ACTIVE	CDIP	JG	8	1	TBD	A42	N / A for Pkg Type	0 to 70	UC3611J	Samples
UC3611N	ACTIVE	PDIP	P	8	50	Green (RoHS & no Sb/Br)	CU NIPDAU	N / A for Pkg Type	0 to 70	UC3611N	Samples

(1) The marketing status values are defined as follows:

ACTIVE: Product device recommended for new designs.

LIFEBUY: TI has announced that the device will be discontinued, and a lifetime-buy period is in effect.

NRND: Not recommended for new designs. Device is in production to support existing customers, but TI does not recommend using this part in a new design.

PREVIEW: Device has been announced but is not in production. Samples may or may not be available.

OBSOLETE: TI has discontinued the production of the device.

(2) **RoHS:** TI defines "RoHS" to mean semiconductor products that are compliant with the current EU RoHS requirements for all 10 RoHS substances, including the requirement that RoHS substance do not exceed 0.1% by weight in homogeneous materials. Where designed to be soldered at high temperatures, "RoHS" products are suitable for use in specified lead-free processes. TI may reference these types of products as "Pb-Free".

RoHS Exempt: TI defines "RoHS Exempt" to mean products that contain lead but are compliant with EU RoHS pursuant to a specific EU RoHS exemption.

Green: TI defines "Green" to mean the content of Chlorine (Cl) and Bromine (Br) based flame retardants meet JS709B low halogen requirements of <=1000ppm threshold. Antimony trioxide based flame retardants must also meet the <=1000ppm threshold requirement.

(3) MSL, Peak Temp. - The Moisture Sensitivity Level rating according to the JEDEC industry standard classifications, and peak solder temperature.

(4) There may be additional marking, which relates to the logo, the lot trace code information, or the environmental category on the device.

(5) Multiple Device Markings will be inside parentheses. Only one Device Marking contained in parentheses and separated by a "~" will appear on a device. If a line is indented then it is a continuation of the previous line and the two combined represent the entire Device Marking for that device.

(6) Lead/Ball Finish - Orderable Devices may have multiple material finish options. Finish options are separated by a vertical ruled line. Lead/Ball Finish values may wrap to two lines if the finish value exceeds the maximum column width.

Important Information and Disclaimer: The information provided on this page represents TI's knowledge and belief as of the date that it is provided. TI bases its knowledge and belief on information provided by third parties, and makes no representation or warranty as to the accuracy of such information. Efforts are underway to better integrate information from third parties. TI has taken and continues to take reasonable steps to provide representative and accurate information but may not have conducted destructive testing or chemical analysis on incoming materials and chemicals. TI and TI suppliers consider certain information to be proprietary, and thus CAS numbers and other limited information may not be available for release.

In no event shall TI's liability arising out of such information exceed the total purchase price of the TI part(s) at issue in this document sold by TI to Customer on an annual basis.

OTHER QUALIFIED VERSIONS OF UC1611, UC1611-SP, UC3611, UC3611M :

● Catalog: [UC3611](#), [UC1611](#), [UC3611M](#), [UC3611](#)

● Military: [UC1611](#), [UC1611](#)

● Space: [UC1611-SP](#)

NOTE: Qualified Version Definitions:

● Catalog - TI's standard catalog product

● Military - QML certified for Military and Defense Applications

● Space - Radiation tolerant, ceramic packaging and qualified for use in Space-based application

IMPORTANT NOTICE AND DISCLAIMER

TI PROVIDES TECHNICAL AND RELIABILITY DATA (INCLUDING DATASHEETS), DESIGN RESOURCES (INCLUDING REFERENCE DESIGNS), APPLICATION OR OTHER DESIGN ADVICE, WEB TOOLS, SAFETY INFORMATION, AND OTHER RESOURCES "AS IS" AND WITH ALL FAULTS, AND DISCLAIMS ALL WARRANTIES, EXPRESS AND IMPLIED, INCLUDING WITHOUT LIMITATION ANY IMPLIED WARRANTIES OF MERCHANTABILITY, FITNESS FOR A PARTICULAR PURPOSE OR NON-INFRINGEMENT OF THIRD PARTY INTELLECTUAL PROPERTY RIGHTS.

These resources are intended for skilled developers designing with TI products. You are solely responsible for (1) selecting the appropriate TI products for your application, (2) designing, validating and testing your application, and (3) ensuring your application meets applicable standards, and any other safety, security, or other requirements. These resources are subject to change without notice. TI grants you permission to use these resources only for development of an application that uses the TI products described in the resource. Other reproduction and display of these resources is prohibited. No license is granted to any other TI intellectual property right or to any third party intellectual property right. TI disclaims responsibility for, and you will fully indemnify TI and its representatives against, any claims, damages, costs, losses, and liabilities arising out of your use of these resources.

TI's products are provided subject to TI's Terms of Sale (www.ti.com/legal/termsofsale.html) or other applicable terms available either on ti.com or provided in conjunction with such TI products. TI's provision of these resources does not expand or otherwise alter TI's applicable warranties or warranty disclaimers for TI products.

Mailing Address: Texas Instruments, Post Office Box 655303, Dallas, Texas 75265
Copyright © 2019, Texas Instruments Incorporated

Looking for pricing, stock, or lifecycle information?

Click below to explore more details on WIN SOURCE:

 [View UC3611N on WIN SOURCE](#)

 [Texas Instruments](#) Information

Optimize Your Supply Chain with WIN SOURCE Solutions

-  Global Sourcing Solution
-  Obsolete Management
-  Cost Control Management
-  Shortage Management
-  Alternative Solution
-  Excess Inventory Management