



THE DATASHEET OF TXDV1212RG



12 A high voltage Triacs

Features

- On-state current ($I_{T(RMS)}$): 12 A
- Max. blocking voltage (V_{DRM}/V_{RRM}): 1200 V
- Gate current (I_{GT}): 100 mA
- Commutation @ 10 V/ μ s: up to 42.5 A/ms
- Noise immunity: 2 kV/ μ s
- Insulated package:
 - 2,500 V rms (UL recognized: E81734).

Description

The TXDVxx12 series uses a high performance alternistor technology.

Featuring very high commutation levels and high surge current capability, these devices are well adapted to power control for inductive and resistive loads (motor, transformer...) especially on three-phase power grid. Targeted three-phase applications include heating systems, motor starters, and induction motor speed control (especially for fans).

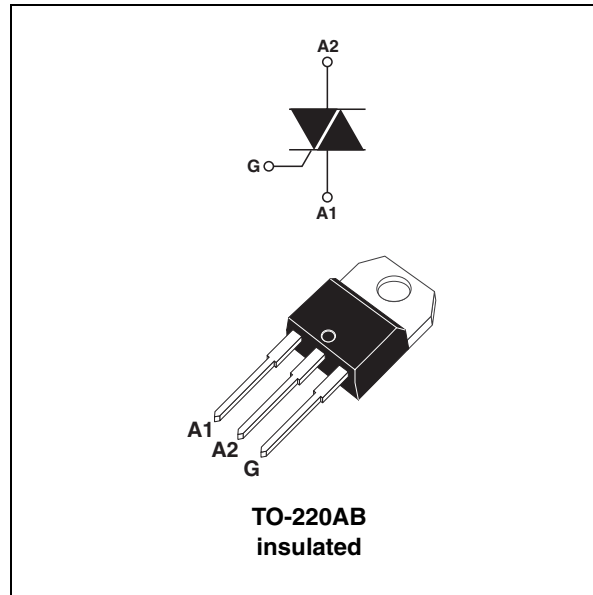

Table 1. Device summary

Parameter	TXDV812RG	TXDV1212RG
Blocking voltage V_{DRM}/V_{RRM}	800 V	1200 V
On-state current $I_{T(RMS)}$	12 A	
Gate current I_{GT}	100 mA	

1 Characteristics

Table 2. Absolute maximum ratings (limiting values)

Symbol	Parameter		Value	Unit		
$I_{T(RMS)}$	On-state rms current (180° conduction angle)		$T_c = 90\text{ °C}$	12	A	
V_{DRM} V_{RRM}	Repetitive peak off-state voltage		TXDV812	$T_j = 125\text{ °C}$	800	V
			TXDV1212		1200	
I_{TSM}	Non repetitive surge peak on-state current		$t_p = 2.5\text{ ms}$	$T_j = 25\text{ °C}$	170	A
			$t_p = 8.3\text{ ms}$		125	
			$t_p = 10\text{ ms}$		120	
I^2t	I^2t value for fusing	$t_p = 10\text{ ms}$		72	A^2s	
di/dt	Critical rate of rise of on-state current $I_G = 500\text{ mA}$ $di_G/dt = 1\text{ A}/\mu s$	$F = 50\text{ Hz}$		100	$A/\mu s$	
T_{stg} T_j	Storage junction temperature range Operating junction temperature range			- 40 to + 150 - 40 to + 125	$^{\circ}C$	
$V_{INS(RMS)}^{(1)}$	Insulation rms voltage			2500	V	

1. A1, A2, gate terminals to case for 1 minute

Table 3. Electrical characteristics ($T_j = 25\text{ °C}$, unless otherwise specified)

Symbol	Test conditions	Quadrant		Value		Unit	
				TXDV812	TXDV1212		
I_{GT}	$V_D = 12\text{ V DC}$, $R_L = 33\ \Omega$	I-II-III	MAX.	100		mA	
V_{GT}		I-II-III	MAX.	1.5		V	
V_{GD}	$V_D = V_{DRM}$ $R_L = 3.3\text{ k}\Omega$ $T_j = 110\text{ °C}$	I-II-III	MIN.	0.2		V	
t_{gt}	$V_D = V_{DRM}$ $I_G = 500\text{ mA}$ $di_G/dt = 3\text{ A}/\mu s$	I-II-III	TYP.	2.5		μs	
I_L	$I_G = 1.2 \times I_{GT}$	I-III	TYP.	100		mA	
		II		200			
$I_H^{(1)}$	$I_T = 500\text{ mA}$ Gate open		MAX.	100		mA	
$dV/dt^{(1)}$	Linear slope up to: $V_D = 67\% V_{DRM}$ Gate open		$T_j = 125\text{ °C}$	MIN.	2		$kV/\mu s$
$(di/dt)_c^{(1)}$	$(dV/dt)_c = 10\text{ V}/\mu s$		$T_j = 110\text{ °C}$	MIN.	42.5	30	A/ms
$V_{TM}^{(1)}$	$I_{TM} = 17\text{ A}$ $t_p = 380\ \mu s$		MAX.	1.95		V	
$V_{to}^{(1)}$	Threshold voltage		MAX.	1.21		V	
$R_d^{(1)}$	Dynamic resistance		MAX.	40		$m\Omega$	
I_{DRM} I_{RRM}	$V_{DRM} = V_{RRM}$		$T_j = 25\text{ °C}$	MAX.	0.01		mA
			$T_j = 110\text{ °C}$		2	5	

1. For either polarity of electrode A_2 voltage with reference to electrode A_1 .

Table 4. Gate characteristics (maximum values)

Symbol	Parameter	Value	Unit
$P_{G(AV)}$	Average gate power dissipation	1	W
P_{GM}	Peak gate power dissipation	$t_p = 20 \mu s$ 10	W
I_{GM}	Peak gate current	$t_p = 20 \mu s$ 4	A
V_{GM}	Peak positive gate voltage	$t_p = 20 \mu s$ 16	V

Table 5. Thermal resistance

Symbol	Parameter	Value	Unit
$R_{th(j-a)}$	Junction to ambient	60	$^{\circ}C/W$
$R_{th(j-c)}$ DC	Junction to case for DC	2.5	$^{\circ}C/W$
$R_{th(j-c)}$ AC	Junction to case for 360 $^{\circ}$ Conduction angle ($F = 50$ Hz)	1.9	$^{\circ}C/W$

Figure 1. Max. rms power dissipation versus on-state rms current ($F = 50$ Hz). (curves limited by $(di/dt)_c$)

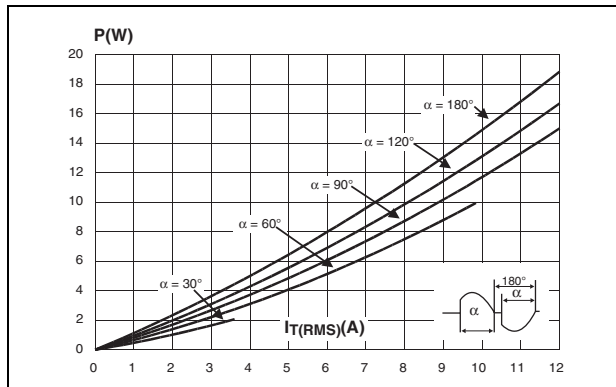

Figure 2. Max. rms power dissipation and max. allowable temperatures (T_{amb} and T_{case}) for various R_{th}

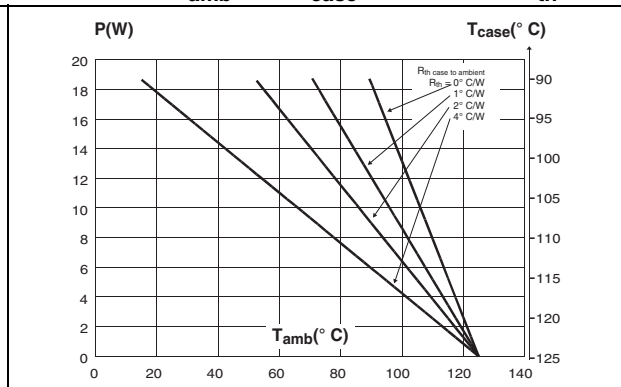

Figure 3. On-state rms current versus case temperature

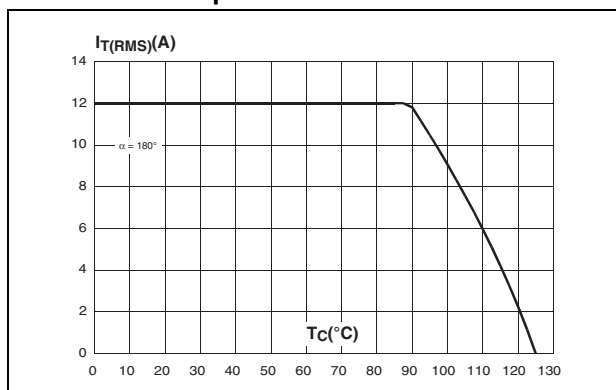

Figure 4. Relative variation of thermal impedance versus pulse duration

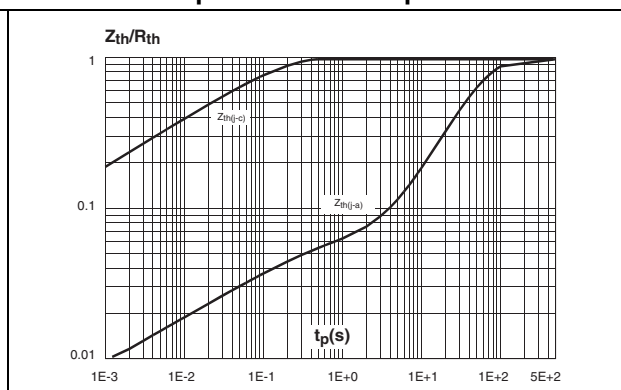

Figure 5. Relative variation of gate trigger current and holding current versus junction temperature

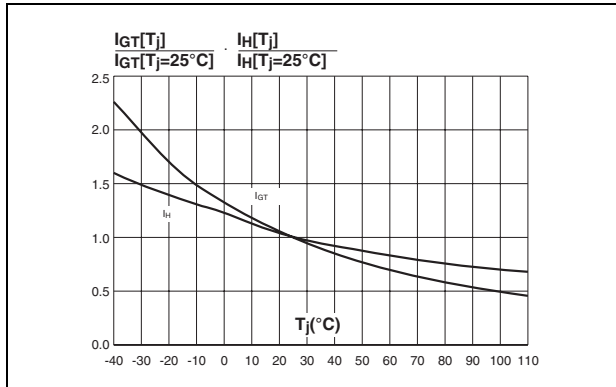

Figure 6. Non repetitive surge peak on-state current versus number of cycles

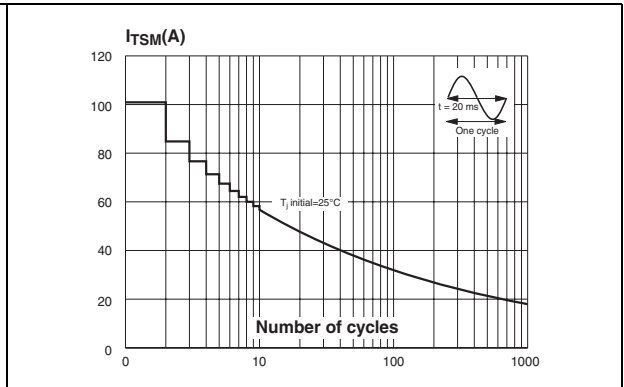

Figure 7. Non-repetitive surge peak on-state current for a sinusoidal pulse and corresponding values of I²t

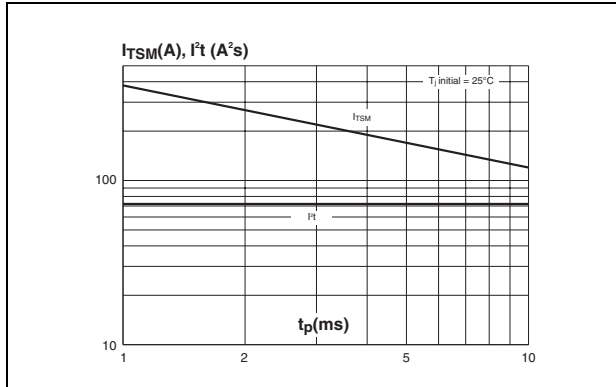

Figure 8. On-state characteristics (maximum values)

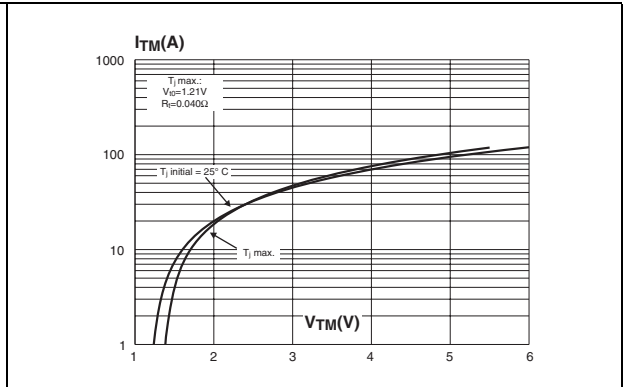
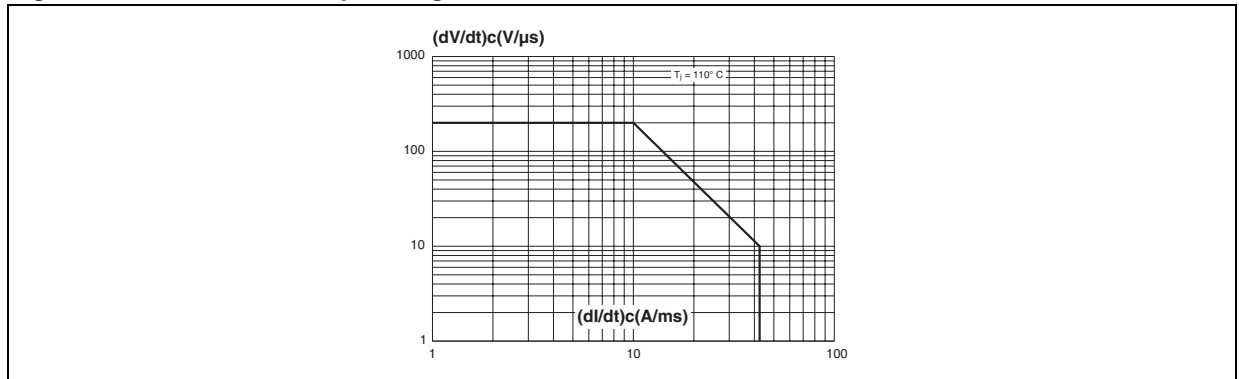

Figure 9. Safe turn-off operating area



2 Package information

- Epoxy meets UL94,V0
- Cooling method: C (by conduction)
- Recommended torque value: 0.4 to 0.6 N·m

In order to meet environmental requirements, ST offers these devices in different grades of ECOPACK® packages, depending on their level of environmental compliance. ECOPACK® specifications, grade definitions and product status are available at: www.st.com. ECOPACK® is an ST trademark.

Table 6. TO-220AB insulated dimensions

Ref.	Dimensions					
	Millimeters			Inches		
	Min.	Typ.	Max.	Min.	Typ.	Max.
A	15.20		15.90	0.598		0.625
a1		3.75			0.147	
a2	13.00		14.00	0.511		0.551
B	10.00		10.40	0.393		0.409
b1	0.61		0.88	0.024		0.034
b2	1.23		1.32	0.048		0.051
C	4.40		4.60	0.173		0.181
c1	0.49		0.70	0.019		0.027
c2	2.40		2.72	0.094		0.107
e	2.40		2.70	0.094		0.106
F	6.20		6.60	0.244		0.259
ØI	3.75		3.85	0.147		0.151
I4	15.80	16.40	16.80	0.622	0.646	0.661
L	2.65		2.95	0.104		0.116
I2	1.14		1.70	0.044		0.066
I3	1.14		1.70	0.044		0.066
M		2.60			0.102	

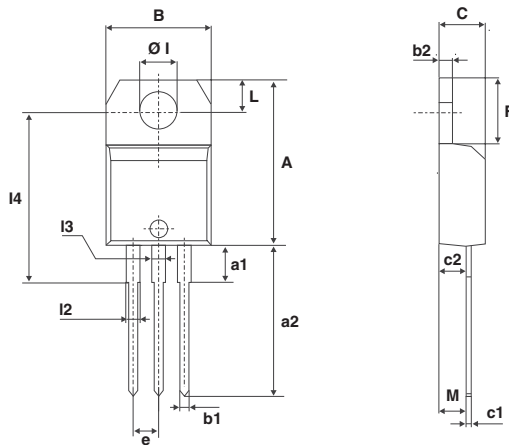

3 Ordering information

Table 7. Ordering information

Order code	Marking	Package	Weight	Base qty	Delivery mode
TXDV812RG	TXDV812	TO-220AB insulated	2.3 g	50	Tube
TXDV1212RG	TXDV1212				

4 Revision history

Table 8. Document revision history

Date	Revision	Changes
30-Mar-2011	1	Initial release.
13-Jan-2012	2	Updated dI/dt in Table 2 , and added V_{t0} and R_d in Table 3

Please Read Carefully:

Information in this document is provided solely in connection with ST products. STMicroelectronics NV and its subsidiaries ("ST") reserve the right to make changes, corrections, modifications or improvements, to this document, and the products and services described herein at any time, without notice.

All ST products are sold pursuant to ST's terms and conditions of sale.

Purchasers are solely responsible for the choice, selection and use of the ST products and services described herein, and ST assumes no liability whatsoever relating to the choice, selection or use of the ST products and services described herein.

No license, express or implied, by estoppel or otherwise, to any intellectual property rights is granted under this document. If any part of this document refers to any third party products or services it shall not be deemed a license grant by ST for the use of such third party products or services, or any intellectual property contained therein or considered as a warranty covering the use in any manner whatsoever of such third party products or services or any intellectual property contained therein.

UNLESS OTHERWISE SET FORTH IN ST'S TERMS AND CONDITIONS OF SALE ST DISCLAIMS ANY EXPRESS OR IMPLIED WARRANTY WITH RESPECT TO THE USE AND/OR SALE OF ST PRODUCTS INCLUDING WITHOUT LIMITATION IMPLIED WARRANTIES OF MERCHANTABILITY, FITNESS FOR A PARTICULAR PURPOSE (AND THEIR EQUIVALENTS UNDER THE LAWS OF ANY JURISDICTION), OR INFRINGEMENT OF ANY PATENT, COPYRIGHT OR OTHER INTELLECTUAL PROPERTY RIGHT.

UNLESS EXPRESSLY APPROVED IN WRITING BY TWO AUTHORIZED ST REPRESENTATIVES, ST PRODUCTS ARE NOT RECOMMENDED, AUTHORIZED OR WARRANTED FOR USE IN MILITARY, AIR CRAFT, SPACE, LIFE SAVING, OR LIFE SUSTAINING APPLICATIONS, NOR IN PRODUCTS OR SYSTEMS WHERE FAILURE OR MALFUNCTION MAY RESULT IN PERSONAL INJURY, DEATH, OR SEVERE PROPERTY OR ENVIRONMENTAL DAMAGE. ST PRODUCTS WHICH ARE NOT SPECIFIED AS "AUTOMOTIVE GRADE" MAY ONLY BE USED IN AUTOMOTIVE APPLICATIONS AT USER'S OWN RISK.

Resale of ST products with provisions different from the statements and/or technical features set forth in this document shall immediately void any warranty granted by ST for the ST product or service described herein and shall not create or extend in any manner whatsoever, any liability of ST.

ST and the ST logo are trademarks or registered trademarks of ST in various countries.

Information in this document supersedes and replaces all information previously supplied.

The ST logo is a registered trademark of STMicroelectronics. All other names are the property of their respective owners.

© 2012 STMicroelectronics - All rights reserved

STMicroelectronics group of companies

Australia - Belgium - Brazil - Canada - China - Czech Republic - Finland - France - Germany - Hong Kong - India - Israel - Italy - Japan - Malaysia - Malta - Morocco - Philippines - Singapore - Spain - Sweden - Switzerland - United Kingdom - United States of America

www.st.com

Looking for pricing, stock, or lifecycle information?

Click below to explore more details on WIN SOURCE:

- ⊖ [View TXDV1212RG](#) on WIN SOURCE
- ⊖ [STMicroelectronics](#) Information

Optimize Your Supply Chain with WIN SOURCE Solutions

- ✓ Global Sourcing Solution
- ✓ Obsolete Management
- ✓ Cost Control Management
- ✓ Shortage Management
- ✓ Alternative Solution
- ✓ Excess Inventory Management