



**THE DATASHEET OF
LM3420M5-12.6**



LM3420

LM3420-4.2, -8.2, -8.4, -12.6, -16.8 Lithium-Ion Battery Charge Controller



Literature Number: SNVS116C

Connection Diagrams and Order Information

5-Lead Small Outline Package (M5)

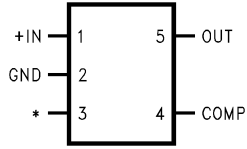

01235903

*No internal connection, but should be soldered to PC board for best heat transfer.

Actual Size



01235904

Top View

For Ordering Information See *Figure 1* in this Data Sheet See NS Package Number MF05A

Absolute Maximum Ratings (Note 1)

If Military/Aerospace specified devices are required, please contact the National Semiconductor Sales Office/Distributors for availability and specifications.

Input Voltage V(IN)	20V
Output Current	20 mA
Junction Temperature	150°C
Storage Temperature	-65°C to +150°C
Lead Temperature	
Vapor Phase (60 seconds)	+215°C
Infrared (15 seconds)	+220°C
Power Dissipation (T _A = 25°C)	
(Note 2)	300 mW

ESD Susceptibility (Note 3)

Human Body Model 1500V

See AN-450 "Surface Mounting Methods and Their Effect on Product Reliability" for methods on soldering surface-mount devices.

Operating Ratings (Notes 1, 2)

Ambient Temperature Range	-40°C ≤ T _A ≤ +85°C
Junction Temperature Range	-40°C ≤ T _J ≤ +125°C
Output Current	15 mA

LM3420-4.2

Electrical Characteristics

Specifications with standard type face are for T_J = 25°C, and those with **boldface type** apply over **full Operating Temperature Range**. Unless otherwise specified, V(IN) = V_{REG}, V_{OUT} = 1.5V.

Symbol	Parameter	Conditions	Typical (Note 4)	LM3420A-4.2 Limit (Note 5)	LM3420-4.2 Limit (Note 5)	Units (Limits)
V _{REG}	Regulation Voltage	I _{OUT} = 1 mA	4.2	4.221/ 4.242 4.179/ 4.158	4.242/ 4.284 4.158/ 4.116	V V(max) V(min)
	Regulation Voltage Tolerance	I _{OUT} = 1 mA		±0.5/ ±1	±1/ ±2	%(max)
I _q	Quiescent Current	I _{OUT} = 1 mA	85	110/ 115	125/ 150	μA μA(max)
G _m	Transconductance ΔI _{OUT} /ΔV _{REG}	20 μA ≤ I _{OUT} ≤ 1 mA V _{OUT} = 2V	3.3	1.3/ 0.75	1.0/ 0.50	mA/mV mA/mV(min)
		1 mA ≤ I _{OUT} ≤ 15 mA V _{OUT} = 2V	6.0	3.0/ 1.5	2.5/ 1.4	mA/mV mA/mV(min)
A _V	Voltage Gain ΔV _{OUT} /ΔV _{REG}	1V ≤ V _{OUT} ≤ V _{REG} - 1.2V (-1.3) R _L = 200Ω (Note 6)	1000	550/ 250	450/ 200	V/V V/V(min)
		1V ≤ V _{OUT} ≤ V _{REG} - 1.2V (-1.3) R _L = 2 kΩ	3500	1500/ 900	1000/ 700	V/V V/V(min)
V _{SAT}	Output Saturation (Note 7)	V(IN) = V _{REG} + 100 mV I _{OUT} = 15 mA	1.0	1.2/ 1.3	1.2/ 1.3	V V(max)
I _L	Output Leakage Current	V(IN) = V _{REG} - 100 mV V _{OUT} = 0V	0.1	0.5/ 1.0	0.5/ 1.0	μA μA(max)
R _f	Internal Feedback Resistor (Note 8)		75	94	94	kΩ kΩ(max)
				56	56	kΩ(min)
E _n	Output Noise Voltage	I _{OUT} = 1 mA, 10 Hz ≤ f ≤ 10 kHz	70			μV _{RMS}

LM3420-8.2 Electrical Characteristics

Specifications with standard type face are for $T_J = 25^\circ\text{C}$, and those with **boldface type** apply over **full Operating Temperature Range**. Unless otherwise specified, $V(\text{IN}) = V_{\text{REG}}$, $V_{\text{OUT}} = 1.5\text{V}$.

Symbol	Parameter	Conditions	Typical (Note 4)	LM3420A-8.2 Limit (Note 5)	LM3420-8.2 Limit (Note 5)	Units (Limits)
V_{REG}	Regulation Voltage	$I_{\text{OUT}} = 1\text{ mA}$	8.2	8.241/ 8.282 8.159/ 8.118	8.282/ 8.364 8.118/ 8.036	V V(max) V(min)
	Regulation Voltage Tolerance	$I_{\text{OUT}} = 1\text{ mA}$		$\pm 0.5/\pm 1$	$\pm 1/\pm 2$	%(max)
I_{q}	Quiescent Current	$I_{\text{OUT}} = 1\text{ mA}$	85	110/ 115	125/ 150	μA $\mu\text{A}(\text{max})$
G_{m}	Transconductance $\Delta I_{\text{OUT}}/\Delta V_{\text{REG}}$	$20\ \mu\text{A} \leq I_{\text{OUT}} \leq 1\text{ mA}$ $V_{\text{OUT}} = 6\text{V}$	3.3	1.3/ 0.75	1.0/ 0.50	mA/mV $\text{mA}/\text{mV}(\text{min})$
		$1\text{ mA} \leq I_{\text{OUT}} \leq 15\text{ mA}$ $V_{\text{OUT}} = 6\text{V}$	6.0	3.0/ 1.5	2.5/ 1.4	mA/mV $\text{mA}/\text{mV}(\text{min})$
A_{V}	Voltage Gain $\Delta V_{\text{OUT}}/\Delta V_{\text{REG}}$	$1\text{V} \leq V_{\text{OUT}} \leq V_{\text{REG}} - 1.2\text{V}$ (-1.3) $R_{\text{L}} = 470\Omega$ (Note 6)	1000	550/ 250	450/ 200	V/V V/V(min)
		$1\text{V} \leq V_{\text{OUT}} \leq V_{\text{REG}} - 1.2\text{V}$ (-1.3) $R_{\text{L}} = 5\text{ k}\Omega$	3500	1500/ 900	1000/ 700	V/V V/V(min)
V_{SAT}	Output Saturation (Note 7)	$V(\text{IN}) = V_{\text{REG}} + 100\text{ mV}$ $I_{\text{OUT}} = 15\text{ mA}$	1.0	1.2/ 1.3	1.2/ 1.3	V V(max)
I_{L}	Output Leakage Current	$V(\text{IN}) = V_{\text{REG}} - 100\text{ mV}$ $V_{\text{OUT}} = 0\text{V}$	0.1	0.5/ 1.0	0.5/ 1.0	μA $\mu\text{A}(\text{max})$
R_{f}	Internal Feedback Resistor (Note 8)		176	220	220	$\text{k}\Omega$ $\text{k}\Omega(\text{max})$
				132	132	$\text{k}\Omega(\text{min})$
E_{n}	Output Noise Voltage	$I_{\text{OUT}} = 1\text{ mA}$, $10\text{ Hz} \leq f \leq 10\text{ kHz}$	140			μV_{RMS}

LM3420-8.4 Electrical Characteristics

Specifications with standard type face are for $T_J = 25^\circ\text{C}$, and those with **boldface type** apply over **full Operating Temperature Range**. Unless otherwise specified, $V(\text{IN}) = V_{\text{REG}}$, $V_{\text{OUT}} = 1.5\text{V}$.

Symbol	Parameter	Conditions	Typical (Note 4)	LM3420A-8.4 Limit (Note 5)	LM3420-8.4 Limit (Note 5)	Units (Limits)
V_{REG}	Regulation Voltage	$I_{\text{OUT}} = 1\text{ mA}$	8.4	8.442/ 8.484 8.358/ 8.316	8.484/ 8.568 8.316/ 8.232	V V(max) V(min)
	Regulation Voltage Tolerance	$I_{\text{OUT}} = 1\text{ mA}$		$\pm 0.5/\pm 1$	$\pm 1/\pm 2$	%(max)
I_{q}	Quiescent Current	$I_{\text{OUT}} = 1\text{ mA}$	85	110/ 115	125/ 150	μA $\mu\text{A}(\text{max})$
G_{m}	Transconductance $\Delta I_{\text{OUT}}/\Delta V_{\text{REG}}$	$20\ \mu\text{A} \leq I_{\text{OUT}} \leq 1\text{ mA}$ $V_{\text{OUT}} = 6\text{V}$	3.3	1.3/ 0.75	1.0/ 0.50	mA/mV $\text{mA}/\text{mV}(\text{min})$
		$1\text{ mA} \leq I_{\text{OUT}} \leq 15\text{ mA}$ $V_{\text{OUT}} = 6\text{V}$	6.0	3.0/ 1.5	2.5/ 1.4	mA/mV $\text{mA}/\text{mV}(\text{min})$

LM3420-8.4

Electrical Characteristics (Continued)

Specifications with standard type face are for $T_J = 25^\circ\text{C}$, and those with **boldface type** apply over **full Operating Temperature Range**. Unless otherwise specified, $V(\text{IN}) = V_{\text{REG}}$, $V_{\text{OUT}} = 1.5\text{V}$.

Symbol	Parameter	Conditions	Typical (Note 4)	LM3420A-8.4 Limit (Note 5)	LM3420-8.4 Limit (Note 5)	Units (Limits)
A_V	Voltage Gain $\Delta V_{\text{OUT}}/\Delta V_{\text{REG}}$	$1\text{V} \leq V_{\text{OUT}} \leq V_{\text{REG}} - 1.2\text{V}$ (-1.3) $R_L = 470\Omega$ (Note 6)	1000	550/ 250	450/ 200	V/V V/V(min)
		$1\text{V} \leq V_{\text{OUT}} \leq V_{\text{REG}} - 1.2\text{V}$ (-1.3) $R_L = 5\text{ k}\Omega$	3500	1500/ 900	1000/ 700	V/V V/V(min)
V_{SAT}	Output Saturation (Note 7)	$V(\text{IN}) = V_{\text{REG}} + 100\text{ mV}$ $I_{\text{OUT}} = 15\text{ mA}$	1.0	1.2/ 1.3	1.2/ 1.3	V V(max)
I_L	Output Leakage Current	$V(\text{IN}) = V_{\text{REG}} - 100\text{ mV}$ $V_{\text{OUT}} = 0\text{V}$	0.1	0.5/ 1.0	0.5/ 1.0	μA $\mu\text{A}(\text{max})$
R_f	Internal Feedback Resistor (Note 8)		181	227	227	$\text{k}\Omega$ $\text{k}\Omega(\text{max})$
				135	135	$\text{k}\Omega(\text{min})$
E_n	Output Noise Voltage	$I_{\text{OUT}} = 1\text{ mA}$, $10\text{ Hz} \leq f \leq 10\text{ kHz}$	140			μV_{RMS}

LM3420-12.6

Electrical Characteristics

Specifications with standard type face are for $T_J = 25^\circ\text{C}$, and those with **boldface type** apply over **full Operating Temperature Range**. Unless otherwise specified, $V(\text{IN}) = V_{\text{REG}}$, $V_{\text{OUT}} = 1.5\text{V}$.

Symbol	Parameter	Conditions	Typical (Note 4)	LM3420A-12.6 Limit (Note 5)	LM3420-12.6 Limit (Note 5)	Units (Limits)
V_{REG}	Regulation Voltage	$I_{\text{OUT}} = 1\text{ mA}$	12.6	12.663/ 12.726 12.537/ 12.474	12.726/ 12.852 12.474/ 12.348	V V(max) V(min)
					$\pm 0.5/\pm 1$	$\pm 1/\pm 2$
I_q	Quiescent Current	$I_{\text{OUT}} = 1\text{ mA}$	85	110/ 115	125/ 150	μA $\mu\text{A}(\text{max})$
G_m	Transconductance $\Delta I_{\text{OUT}}/\Delta V_{\text{REG}}$	$20\text{ }\mu\text{A} \leq I_{\text{OUT}} \leq 1\text{ mA}$ $V_{\text{OUT}} = 10\text{V}$	3.3	1.3/ 0.75	1.0/ 0.5	mA/mV $\text{mA}/\text{mV}(\text{min})$
		$1\text{ mA} \leq I_{\text{OUT}} \leq 15\text{ mA}$ $V_{\text{OUT}} = 10\text{V}$	6.0	3.0/ 1.5	2.5/ 1.4	mA/mV $\text{mA}/\text{mV}(\text{min})$
A_V	Voltage Gain $\Delta V_{\text{OUT}}/\Delta V_{\text{REG}}$	$1\text{V} \leq V_{\text{OUT}} \leq V_{\text{REG}} - 1.2\text{V}$ (-1.3) $R_L = 750\Omega$ (Note 6)	1000	550/ 250	450/ 200	V/V V/V(min)
		$1\text{V} \leq V_{\text{OUT}} \leq V_{\text{REG}} - 1.2\text{V}$ (-1.3) $R_L = 10\text{ k}\Omega$	3500	1500/ 900	1000/ 700	V/V V/V(min)
V_{SAT}	Output Saturation (Note 7)	$V(\text{IN}) = V_{\text{REG}} + 100\text{ mV}$ $I_{\text{OUT}} = 15\text{ mA}$	1.0	1.2/ 1.3	1.2/ 1.3	V V(max)
I_L	Output Leakage Current	$V(\text{IN}) = V_{\text{REG}} - 100\text{ mV}$ $V_{\text{OUT}} = 0\text{V}$	0.1	0.5/ 1.0	0.5/ 1.0	μA $\mu\text{A}(\text{max})$
R_f	Internal Feedback Resistor (Note 8)		287	359	359	$\text{k}\Omega$ $\text{k}\Omega(\text{max})$
				215	215	$\text{k}\Omega(\text{min})$
E_n	Output Noise Voltage	$I_{\text{OUT}} = 1\text{ mA}$, $10\text{ Hz} \leq f \leq 10\text{ kHz}$	210			μV_{RMS}

LM3420-16.8

Electrical Characteristics

Specifications with standard type face are for $T_J = 25^\circ\text{C}$, and those with **boldface type** apply over **full Operating Temperature Range**. Unless otherwise specified, $V(\text{IN}) = V_{\text{REG}}$, $V_{\text{OUT}} = 1.5\text{V}$.

Symbol	Parameter	Conditions	Typical (Note 4)	LM3420A-16.8 Limit (Note 5)	LM3420-16.8 Limit (Note 5)	Units (Limits)
V_{REG}	Regulation Voltage	$I_{\text{OUT}} = 1\text{ mA}$	16.8	16.884/ 16.968 16.716/ 16.632	16.968/ 17.136 16.632/ 16.464	V V(max) V(min)
	Regulation Voltage Tolerance	$I_{\text{OUT}} = 1\text{ mA}$		$\pm 0.5/\pm 1$	$\pm 1/\pm 2$	%(max)
I_{q}	Quiescent Current	$I_{\text{OUT}} = 1\text{ mA}$	85	110/ 115	125/ 150	μA $\mu\text{A}(\text{max})$
G_{m}	Transconductance $\Delta I_{\text{OUT}}/\Delta V_{\text{REG}}$	$20\ \mu\text{A} \leq I_{\text{OUT}} \leq 1\text{ mA}$ $V_{\text{OUT}} = 15\text{V}$	3.3	0.8/0.4	0.7/0.35	mA/mV $\text{mA}/\text{mV}(\text{min})$
		$1\text{ mA} \leq I_{\text{OUT}} \leq 15\text{ mA}$ $V_{\text{OUT}} = 15\text{V}$	6.0	2.9/0.9	2.5/0.75	mA/mV $\text{mA}/\text{mV}(\text{min})$
A_{V}	Voltage Gain $\Delta V_{\text{OUT}}/\Delta V_{\text{REG}}$	$1\text{V} \leq V_{\text{OUT}} \leq V_{\text{REG}} - 1.2\text{V}$ (-1.3) $R_{\text{L}} = 1\text{ k}\Omega$ (Note 6)	1000	550/250	450/200	V/V V/V(min)
		$1\text{V} \leq V_{\text{OUT}} \leq V_{\text{REG}} - 1.2\text{V}$ (-1.3) $R_{\text{L}} = 15\text{ k}\Omega$	3500	1200/750	1000/650	V/V V/V(min)
V_{SAT}	Output Saturation (Note 7)	$V(\text{IN}) = V_{\text{REG}} + 100\text{ mV}$ $I_{\text{OUT}} = 15\text{ mA}$	1.0	1.2/1.3	1.2/1.3	V V(max)
I_{L}	Output Leakage Current	$V(\text{IN}) = V_{\text{REG}} - 100\text{ mV}$ $V_{\text{OUT}} = 0\text{V}$	0.1	0.5/1.0	0.5/1.0	μA $\mu\text{A}(\text{max})$
R_{f}	Internal Feedback Resistor (Note 8)		392	490	490	$\text{k}\Omega$ $\text{k}\Omega(\text{max})$
				294	294	$\text{k}\Omega(\text{min})$
E_{n}	Output Noise Voltage	$I_{\text{OUT}} = 1\text{ mA}$, $10\text{ Hz} \leq f \leq 10\text{ kHz}$	280			μV_{RMS}

Note 1: Absolute Maximum Ratings indicate limits beyond which damage to the device may occur. Operating Ratings indicate conditions for which the device is intended to be functional, but do not guarantee specific performance limits. For guaranteed specifications and test conditions, see the Electrical Characteristics. The guaranteed specifications apply only for the test conditions listed. Some performance characteristics may degrade when the device is not operated under the listed test conditions.

Note 2: The maximum power dissipation must be derated at elevated temperatures and is dictated by T_{Jmax} (maximum junction temperature), θ_{JA} (junction to ambient thermal resistance), and T_{A} (ambient temperature). The maximum allowable power dissipation at any temperature is $P_{\text{Dmax}} = (T_{\text{Jmax}} - T_{\text{A}})/\theta_{\text{JA}}$ or the number given in the Absolute Maximum Ratings, whichever is lower. The typical thermal resistance (θ_{JA}) when soldered to a printed circuit board is approximately $306^\circ\text{C}/\text{W}$ for the M5 package.

Note 3: The human body model is a 100 pF capacitor discharged through a $1.5\text{ k}\Omega$ resistor into each pin.

Note 4: Typical numbers are at 25°C and represent the most likely parametric norm.

Note 5: Limits are 100% production tested at 25°C . Limits over the operating temperature range are guaranteed through correlation using Statistical Quality Control (SQC) methods. The limits are used to calculate National's Averaging Outgoing Quality Level (AOQL).

Note 6: Actual test is done using equivalent current sink instead of a resistor load.

Note 7: $V_{\text{SAT}} = V(\text{IN}) - V_{\text{OUT}}$, when the voltage at the IN pin is forced 100 mV above the nominal regulating voltage (V_{REG}).

Note 8: See Applications and Typical Performance Characteristics sections for information on this resistor.

Typical Performance Characteristics

4.2V Bode Plot

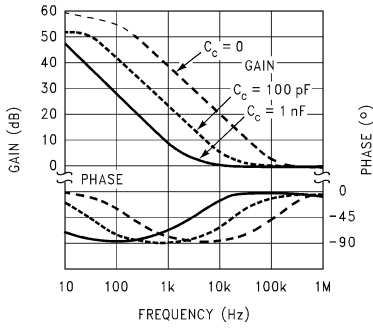

01235917

Response Time for 4.2V Version

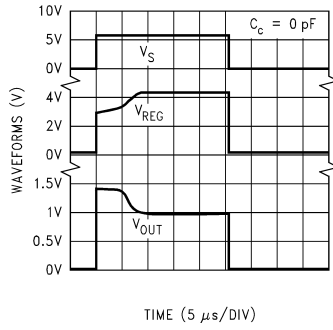

01235918

Response Time for 4.2V Version

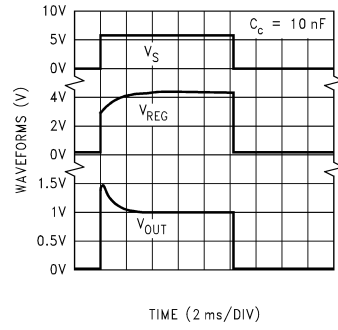

01235919

8.2V and 8.4V Bode Plot

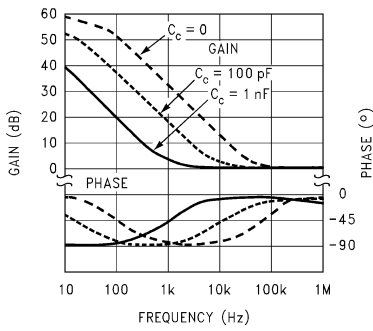

01235920

Response Time for 8.2V, 8.4V Versions

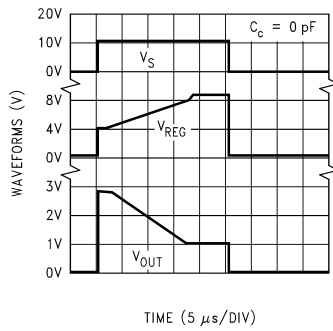

01235921

Response Time for 8.2V, 8.4V Versions

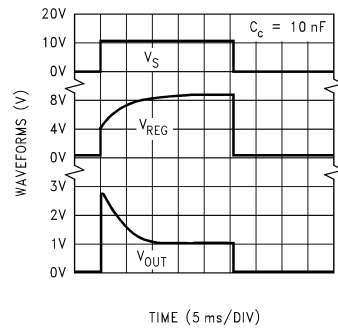

01235922

12.6V Bode Plot

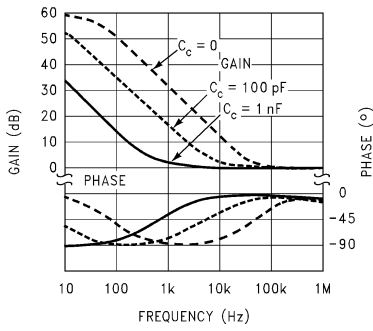

01235923

Response Time for 12.6V Version

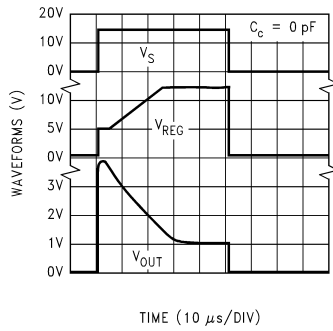

01235924

Response Time for 12.6V Version

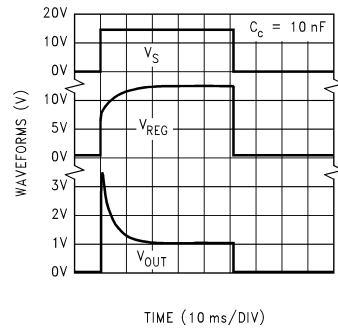

01235925

16.8V Bode Plot

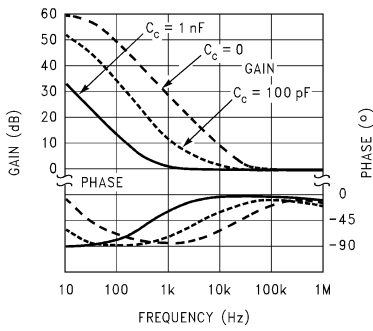

01235926

Response Time for 16.8V Version

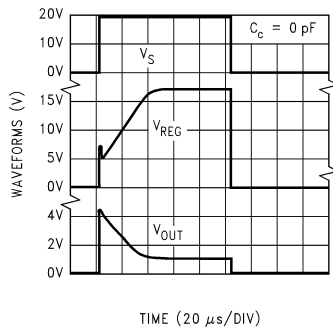

01235927

Response Time for 16.8V Version

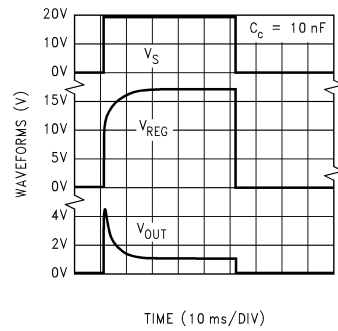

01235928

Typical Performance Characteristics (Continued)

Regulation Voltage vs Output Voltage and Load Resistance

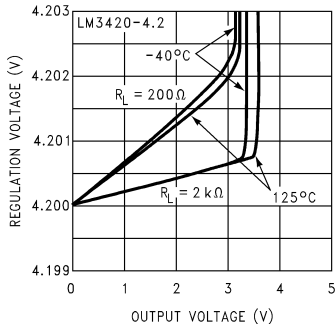

Circuit Used for Bode Plots

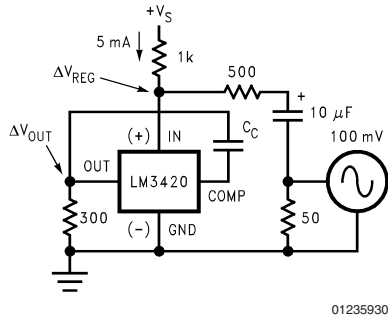

Circuit Used for Response Time

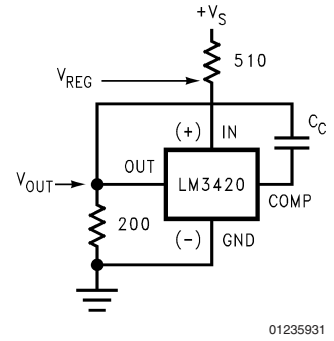

Regulation Voltage vs Output Voltage and Load Resistance

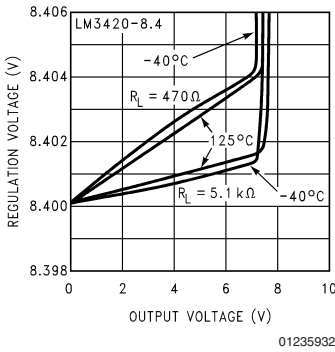

Quiescent Current

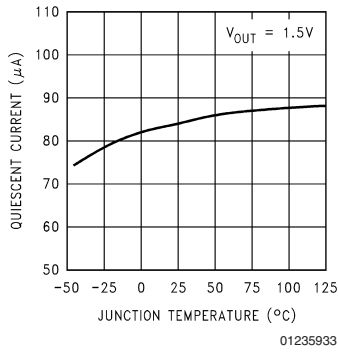

Internal Feedback Resistor (R_f) Tempco

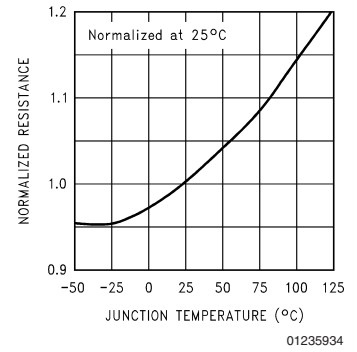

Regulation Voltage vs Output Voltage and Load Resistance

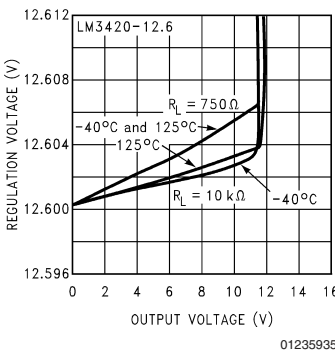

Normalized Temperature Drift

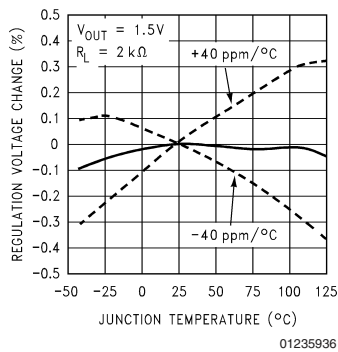

Output Saturation Voltage (V_{SAT})

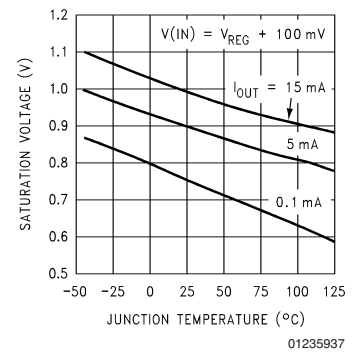

Typical Performance Characteristics (Continued)

Regulation Voltage vs Output Voltage and Load Resistance

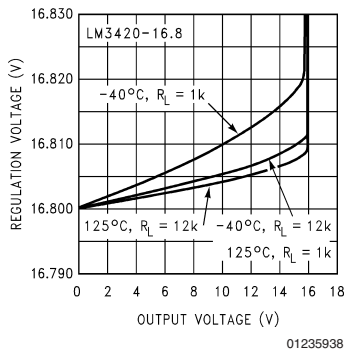

Five Lead Surface Mount Package Information

The small SOT23-5 package allows only 4 alphanumeric characters to identify the product. The table below contains the field information marked on the package.

Voltage	Grade	Order Information	Package Marking	Supplied as
4.2V	A (Prime)	LM3420AM5-4.2	D02A	1000 unit increments on tape and reel
4.2V	A (Prime)	LM3420AM5X-4.2	D02A	3000 unit increments on tape and reel
4.2V	B (Standard)	LM3420M5-4.2	D02B	1000 unit increments on tape and reel
4.2V	B (Standard)	LM3420M5X-4.2	D02B	3000 unit increments on tape and reel
8.2V	A (Prime)	LM3420AM5-8.2	D07A	1000 unit increments on tape and reel
8.2V	A (Prime)	LM3420AM5X-8.2	D07A	3000 unit increments on tape and reel
8.2V	B (Standard)	LM3420M5-8.2	D07B	1000 unit increments on tape and reel
8.2V	B (Standard)	LM3420M5X-8.2	D07B	3000 unit increments on tape and reel
8.4V	A (Prime)	LM3420AM5-8.4	D03A	1000 unit increments on tape and reel
8.4V	A (Prime)	LM3420AM5X-8.4	D03A	3000 unit increments on tape and reel
8.4V	B (Standard)	LM3420M5-8.4	D03B	1000 unit increments on tape and reel
8.4V	B (Standard)	LM3420M5X-8.4	D03B	3000 unit increments on tape and reel
12.6V	A (Prime)	LM3420AM5-12.6	D04A	1000 unit increments on tape and reel
12.6V	A (Prime)	LM3420AM5X-12.6	D04A	3000 unit increments on tape and reel
12.6V	B (Standard)	LM3420M5-12.6	D04B	1000 unit increments on tape and reel
12.6V	B (Standard)	LM3420M5X-12.6	D04B	3000 unit increments on tape and reel
16.8V	A (Prime)	LM3420AM5-16.8	D05A	1000 unit increments on tape and reel
16.8V	A (Prime)	LM3420AM5X-16.8	D05A	3000 unit increments on tape and reel
16.8V	B (Standard)	LM3420M5-16.8	D05B	1000 unit increments on tape and reel
16.8V	B (Standard)	LM3420M5X-16.8	D05B	3000 unit increments on tape and reel

FIGURE 1. SOT23-5 Marking

The first letter “D” identifies the part as a Driver, the next two numbers indicate the voltage, “02” for a 4.2V part, “07” for an 8.2V part, “03” for an 8.4V part, “04” for a 12.6V part, and “05” for a 16.8V part. The fourth letter indicates the grade, “B” for standard grade, “A” for the prime grade.

The SOT23-5 surface mount package is only available on tape in quantity increments of 1000 on tape and reel (indicated by the letters “M5” in the part number), or in quantity increments of 3000 on tape and reel (indicated by the letters “M5X” in the part number).

Product Description

The LM3420 is a shunt regulator specifically designed to be the reference and control section in an overall feedback loop of a Lithium-Ion battery charger. The regulated output voltage is sensed between the IN pin and GROUND pin of the LM3420. If the voltage at the IN pin is less than the LM3420 regulating voltage (V_{REG}), the OUT pin sources no current. As the voltage at the IN pin approaches the V_{REG} voltage, the OUT pin begins sourcing current. This current is then used to drive a feedback device (opto-coupler), or a power device (linear regulator, switching regulator, etc.), which serves the output voltage to be the same value as V_{REG} .

In some applications, (even under normal operating conditions) the voltage on the IN pin can be forced above the V_{REG} voltage. In these instances, the maximum voltage

applied to the IN pin should not exceed 20V. In addition, an external resistor may be required on the OUT pin to limit the maximum current to 20 mA.

Compensation

The inverting input of the error amplifier is brought out to allow overall closed-loop compensation. In many of the applications circuits shown here, compensation is provided by a single capacitor (C_C) connected from the compensation pin to the out pin of the LM3420. The capacitor values shown in the schematics are adequate under most conditions, but they can be increased or decreased depending on the desired loop response. Applying a load pulse to the output of a regulator circuit and observing the resultant output voltage response is an easy method of determining the stability of the control loop.

Analyzing more complex feedback loops requires additional information.

The formula for AC gain at a frequency (f) is as follows;

$$\text{Gain (f)} = 1 + \frac{Z_f(f)}{R_f}$$

$$\text{where } Z_f(f) = \frac{1}{j \cdot 2\pi \cdot f \cdot C_C}$$

Compensation (Continued)

where $R_f \approx 75 \text{ k}\Omega$ for the 4.2V part, $R_f \approx 181 \text{ k}\Omega$ for the 8.4V part, $R_f \approx 287 \text{ k}\Omega$ for the 12.6V part, and $R_f \approx 392 \text{ k}\Omega$ for the 16.8V part.

The resistor (R_f) in the formula is an internal resistor located on the die. Since this resistor value will affect the phase margin, the worst case maximum and minimum values are important when analyzing closed loop stability. The minimum and maximum room temperature values of this resistor are specified in the Electrical Characteristics section of this data sheet, and a curve showing the temperature coefficient is

shown in the curves section. Minimum values of R_f result in lower phase margins.

Test Circuit

The test circuit shown in *Figure 2* can be used to measure and verify various LM3420 parameters. Test conditions are set by forcing the appropriate voltage at the $V_{OUT \text{ Set}}$ test point and selecting the appropriate R_L or I_{OUT} as specified in the Electrical Characteristics section. Use a DVM at the "measure" test points to read the data.

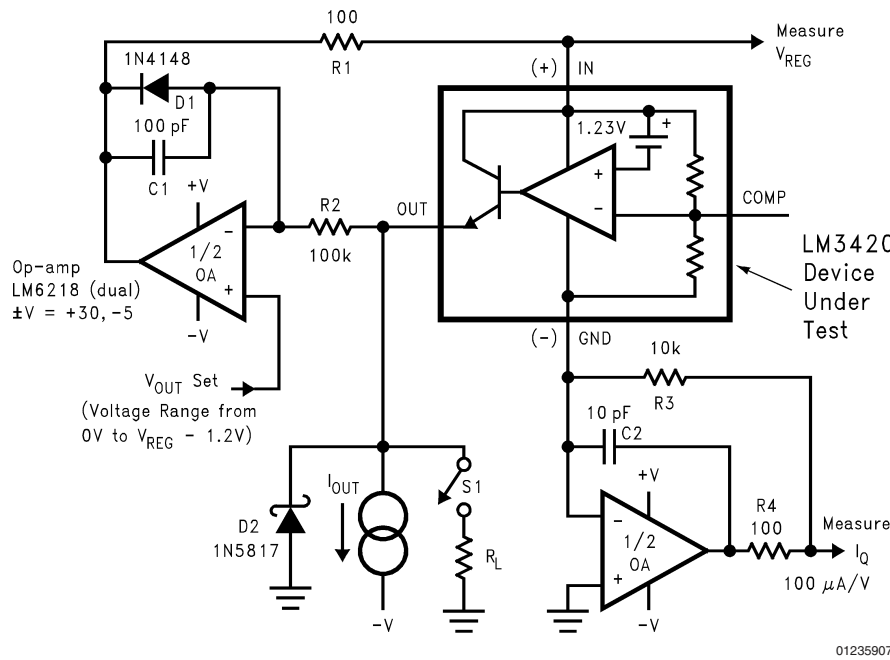
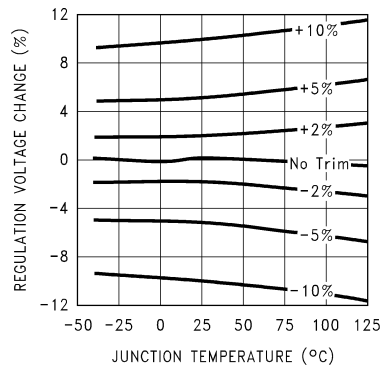

FIGURE 2. LM3420 Test Circuit

V_{REG} External Voltage Trim

The regulation voltage (V_{REG}) of the LM3420 can be externally trimmed by adding a single resistor from the COMP pin to the +IN pin or from the COMP pin to the GND pin, depending on the desired trim direction. Trim adjustments up to $\pm 10\%$ of V_{REG} can be realized, with only a small increase in the temperature coefficient. (See temperature coefficient curve shown in *Figure 3* below.)



Normalized Temperature Drift with Output Externally Trimmed

FIGURE 3.

V_{REG} External Voltage Trim

(Continued)

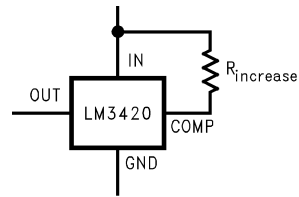

01235909

Increasing V_{REG}

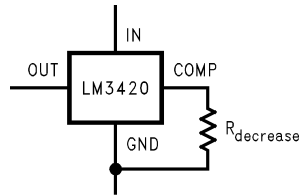

01235910

Decreasing V_{REG}

FIGURE 4. Changing V_{REG}

Formulas for selecting trim resistor values are shown below, based on the percent of increase (%incr) or percent of decrease (%decr) of the output voltage from the nominal voltage.

For LM3420-4.2

$$R_{\text{increase}} = 22 \times 10^5 / \% \text{incr}$$

$$R_{\text{decrease}} = (53 \times 10^5 / \% \text{decr}) - 75 \times 10^3$$

For LM3420-8.2

$$R_{\text{increase}} = 26 \times 10^5 / \% \text{incr}$$

$$R_{\text{decrease}} = (150 \times 10^5 / \% \text{decr}) - 176 \times 10^3$$

For LM3420-8.4

$$R_{\text{increase}} = 26 \times 10^5 / \% \text{incr}$$

$$R_{\text{decrease}} = (154 \times 10^5 / \% \text{decr}) - 181 \times 10^3$$

For LM3420-12.6

$$R_{\text{increase}} = 28 \times 10^5 / \% \text{incr}$$

$$R_{\text{decrease}} = (259 \times 10^5 / \% \text{decr}) - 287 \times 10^3$$

For LM3420-16.8

$$R_{\text{increase}} = 29 \times 10^5 / \% \text{incr}$$

$$R_{\text{decrease}} = (364 \times 10^5 / \% \text{decr}) - 392 \times 10^3$$

Application Information

The LM3420 regulator/driver provides the reference and feedback drive functions for a Lithium-Ion battery charger. It can be used in many different charger configurations using both linear and switching topologies to provide the precision needed for charging Lithium-Ion batteries safely and efficiently. Output voltage tolerances better than 0.5% are possible without using trim pots or precision resistors. The circuits shown are designed for 2 cell operation, but they can readily be changed for either 1, 3 or 4 cell charging applications.

One item to keep in mind when designing with the LM3420 is that there are parasitic diodes present. In some designs, under special electrical conditions, unwanted currents may flow. Parasitic diodes exist from OUT to IN, as well as from GROUND to IN. In both instances the diode arrow is pointed toward the IN pin.

Application Circuits

The circuit shown in *Figure 5* performs constant-current, constant-voltage charging of two Li-Ion cells. At the beginning of the charge cycle, when the battery voltage is less than 8.4V, the LM3420 sources no current from the OUT pin, keeping Q2 off, thus allowing the LM317 Adjustable voltage regulator to operate as a constant-current source. (The LM317 is rated for currents up to 1.5A, and the LM350 and LM338 can be used for higher currents.) The LM317 forces a constant 1.25V across R_{LIM}, thus generating a constant current of

$$I_{\text{LIM}} = 1.25V / R_{\text{LIM}}$$

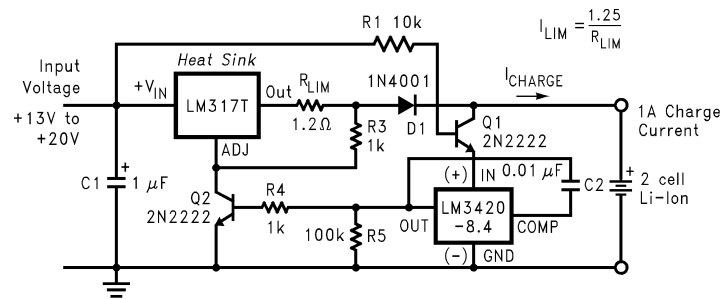

01235901

FIGURE 5. Constant Current/Constant Voltage Li-Ion Battery Charger

Application Circuits (Continued)

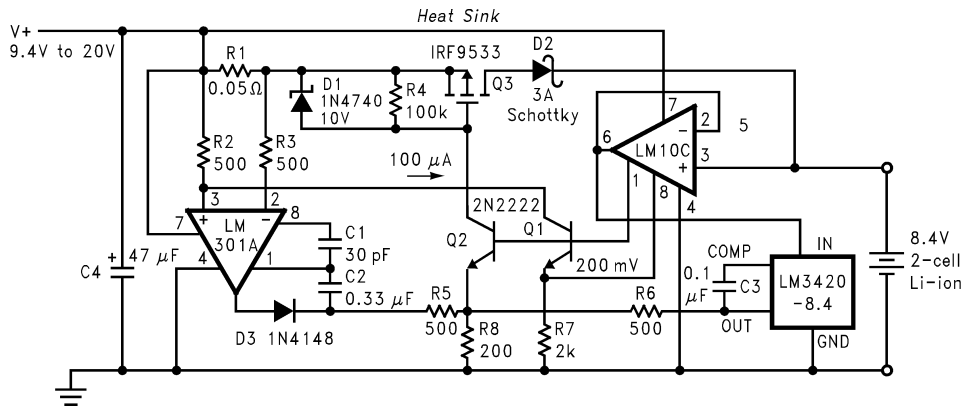

FIGURE 6. Low Drop-Out Constant Current/Constant Voltage 2-Cell Charger

Transistor Q1 provides a disconnect between the battery and the LM3420 when the input voltage is removed. This prevents the 85 μ A quiescent current of the LM3420 from eventually discharging the battery. In this application Q1 is used as a low offset saturated switch, with the majority of the base drive current flowing through the collector and crossing over to the emitter as the battery becomes fully charged. It provides a very low collector to emitter saturation voltage (approximately 5 mV). Diode D1 is also used to prevent the battery current from flowing through the LM317 regulator from the output to the input when the DC input voltage is removed.

As the battery charges, its voltage begins to rise, and is sensed at the IN pin of the LM3420. Once the battery voltage reaches 8.4V, the LM3420 begins to regulate and starts sourcing current to the base of Q2. Transistor Q2 begins controlling the ADJ. pin of the LM317 which begins to regulate the voltage across the battery and the constant voltage portion of the charging cycle starts. Once the charger is in the constant voltage mode, the charger maintains a regulated 8.4V across the battery and the charging current is dependent on the state of charge of the battery. As the cells approach a fully charged condition, the charge current falls to a very low value.

Figure 6 shows a Li-Ion battery charger that features a dropout voltage of less than one volt. This charger is a constant-current, constant-voltage charger (it operates in constant-current mode at the beginning of the charge cycle and switches over to a constant-voltage mode near the end of the charging cycle). The circuit consists of two basic feedback loops. The first loop controls the constant charge current delivered to the battery, and the second determines the final voltage across the battery.

With a discharged battery connected to the charger, (battery voltage is less than 8.4V) the circuit begins the charge cycle with a constant charge current. The value of this current is set by using the reference section of the LM10C to force 200 mV across R7 thus causing approximately 100 μ A of emitter current to flow through Q1, and approximately 1 mA of emitter current to flow through Q2. The collector current of Q1 is also approximately 100 μ A, and this current flows through R2 developing 50 mV across it. This 50 mV is used as a reference to develop the constant charge current through the current sense resistor R1.

The constant current feedback loop operates as follows. Initially, the emitter and collector current of Q2 are both approximately 1 mA, thus providing gate drive to the MOSFET Q3, turning it on. The output of the LM301A op-amp is low. As Q3's current reaches 1A, the voltage across R1 approaches 50 mV, thus canceling the 50 mV drop across R2, and causing the op-amp's output to start going positive, and begin sourcing current into R8. As more current is forced into R8 from the op-amp, the collector current of Q2 is reduced by the same amount, which decreases the gate drive to Q3, to maintain a constant 50 mV across the 0.05 Ω current sensing resistor, thus maintaining a constant 1A of charge current.

The current limit loop is stabilized by compensating the LM301A with C1 (the standard frequency compensation used with this op-amp) and C2, which is additional compensation needed when D3 is forward biased. This helps speed up the response time during the reverse bias of D3. When the LM301A output is low, diode D3 reverse biases and prevents the op-amp from pulling more current through the emitter of Q2. This is important when the battery voltage reaches 8.4V, and the 1A charge current is no longer needed. Resistor R5 isolates the LM301A feedback node at the emitter of Q2.

The battery voltage is sensed and buffered by the op-amp section of the LM10C, connected as a voltage follower driving the LM3420. When the battery voltage reaches 8.4V, the LM3420 will begin regulating by sourcing current into R8, which controls the collector current of Q2, which in turn reduces the gate voltage of Q3 and becomes a constant voltage regulator for charging the battery. Resistor R6 isolates the LM3420 from the common feedback node at the emitter of Q2. If R5 and R6 are omitted, oscillations could occur during the transition from the constant-current to the constant-voltage mode. D2 and the PNP transistor input stage of the LM10C will disconnect the battery from the charger circuit when the input supply voltage is removed to prevent the battery from discharging.

Application Circuits (Continued)

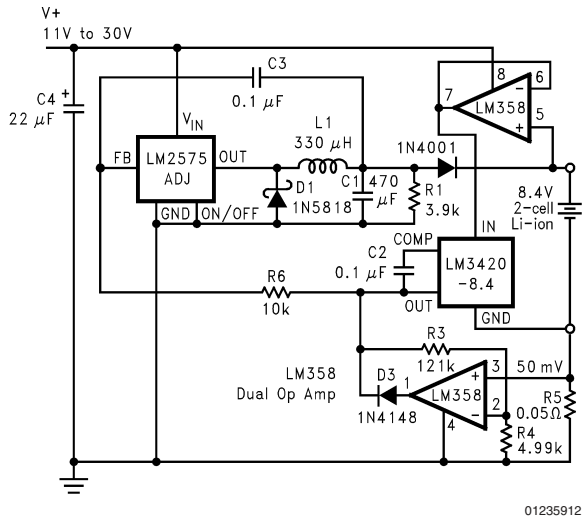

FIGURE 7. High Efficiency Switching Regulator Constant Current/Constant Voltage 2-Cell Charger

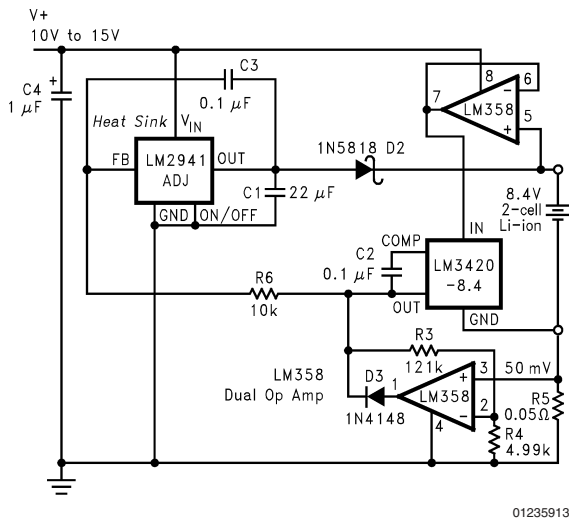

FIGURE 8. Low Dropout Constant Current/Constant Voltage Li-Ion Battery Charger

A switching regulator, constant-current, constant-voltage two-cell Li-Ion battery charging circuit is shown in *Figure 7*. This circuit provides much better efficiency, especially over a wide input voltage range than the linear topologies. For a 1A charger an LM2575-ADJ. switching regulator IC is used in a standard buck topology. For other currents, or other packages, other members of the SIMPLE SWITCHER™ buck regulator family may be used.

Circuit operation is as follows. With a discharged battery connected to the charger, the circuit operates as a constant current source. The constant-current portion of the charger is formed by the loop consisting of one half of the LM358 op amp along with gain setting resistors R3 and R4, current sensing resistor R5, and the feedback reference voltage of 1.23V. Initially the LM358's output is low causing the output of the LM2575-ADJ. to rise thus causing some charging current to flow into the battery. When the current reaches 1A, it is sensed by resistor R5 (50 mΩ), and produces 50 mV. This 50 mV is amplified by the op-amp's gain of 25 to produce 1.23V, which is applied to the feedback pin of the LM2575-ADJ. to satisfy the feedback loop.

Once the battery voltage reaches 8.4V, the LM3420 takes over and begins to control the feedback pin of the LM2575-ADJ. The LM3420 now regulates the voltage across the battery, and the charger becomes a constant-voltage charger. Loop compensation network R6 and C3 ensure stable operation of the charger circuit under both constant-current and constant-voltage conditions. If the input supply voltage is removed, diode D2 and the PNP input stage of the LM358 become reverse biased and disconnects the battery to ensure that the battery is not discharged. Diode D3 reverse biases to prevent the op-amp from sinking current when the charger changes to constant voltage mode.

The minimum supply voltage for this charger is approximately 11V, and the maximum is around 30V (limited by the 32V maximum operating voltage of the LM358). If another op-amp is substituted for the LM358, make sure that the input common-mode range of the op-amp extends down to ground so that it can accurately sense 50 mV. R1 is included to provide a minimum load for the switching regulator to assure that switch leakage current will not cause the output to rise when the battery is removed.

The circuit in *Figure 8* is very similar to *Figure 7*, except the switching regulator has been replaced with a low dropout linear regulator, allowing the input voltage to be as low as 10V. The constant current and constant voltage control loops are the same as the previous circuit. Diode D2 has been changed to a Schottky diode to provide a reduction in the overall dropout voltage of this circuit, but Schottky diodes typically have higher leakage currents than a standard silicon diode. This leakage current could discharge the battery if the input voltage is removed for an extended period of time.

Another variation of a constant current/constant voltage switch mode charger is shown in *Figure 9*. The basic feedback loops for current and voltage are similar to the previous circuits. This circuit has the current sensing resistor, for the constant current part of the feedback loop, on the positive side of the battery, thus allowing a common ground between the input supply and the battery. Also, the LMC7101 op-amp is available in a very small SOT23-5 package thus allowing a very compact pc board design. Diode D4 prevents the battery from discharging through the charger circuitry if the input voltage is removed, although the quiescent current of the LM3420 will still be present (approximately 85 µA).

Application Circuits (Continued)

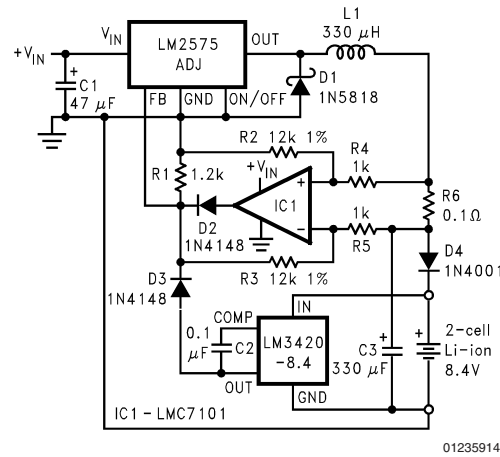

FIGURE 9. High Efficiency Switching Charger with High Side Current Sensing

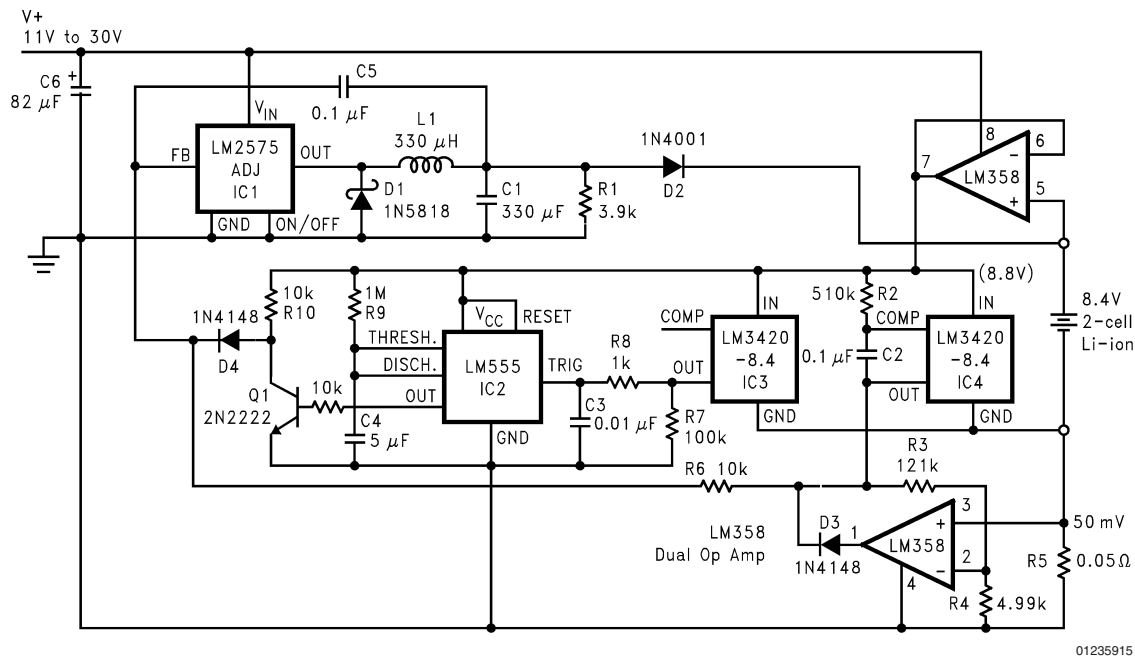

FIGURE 10. (Fast) Pulsed Constant Current 2-Cell Charger

LM3420-4.2/LM3420-8.2/LM3420-8.4/LM3420-12.6/LM3420-16.8

Application Circuits (Continued)

A rapid charge Lithium-Ion battery charging circuit is shown in *Figure 10*. This configuration uses a switching regulator to deliver the charging current in a series of constant current pulses. At the beginning of the charge cycle (constant-current mode), this circuit performs identically to the previous LM2575 charger by charging the battery at a constant current of 1A. As the battery voltage reaches 8.4V, this charger changes from a constant continuous current of 1A to a 5 second pulsed 1A. This allows the total battery charge time to be reduced considerably. This is different from the other charging circuits that switch from a constant current charge to a constant voltage charge once the battery voltage reaches 8.4V. After charging the battery with 1A for 5 seconds, the charge stops, and the battery voltage begins to drop. When it drops below 8.4V, the LM555 timer again starts the timing cycle and charges the battery with 1A for another 5 seconds. This cycling continues with a constant 5 second charge time, and a variable off time. In this manner, the battery will be charged with 1A for 5 seconds, followed by an off period (determined by the battery's state of charge), setting up a periodic 1A charge current. The off time is determined by how long it takes the battery voltage to decrease back down to 8.4V. When the battery first reaches

8.4V, the off time will be very short (1 ms or less), but when the battery approaches full charge, the off time will begin increasing to tens of seconds, then minutes, and eventually hours.

The constant-current loop for this charger and the method used for programming the 1A constant current is identical to the previous LM2575-ADJ. charger. In this circuit, a second LM3420-8.4 has its V_{REG} increased by approximately 400 mV (via R2), and is used to limit the output voltage of the charger to 8.8V in the event of a bad battery connection, or the battery is removed or possibly damaged.

The LM555 timer is connected as a one-shot, and is used to provide the 5 second charging pulses. As long as the battery voltage is less than the 8.4V, the output of IC3 will be held low, and the LM555 one-shot will never fire (the output of the LM555 will be held high) and the one-shot will have no effect on the charger. Once the battery voltage exceeds the 8.4V regulation voltage of IC3, the trigger pin of the LM555 is pulled high, enabling the one shot to begin timing. The charge current will now be pulsed into the battery at a 5 second rate, with the off time determined by the battery's state of charge. The LM555 output will go high for 5 seconds (pulling down the collector of Q1) which allows the 1A constant-current loop to control the circuit.

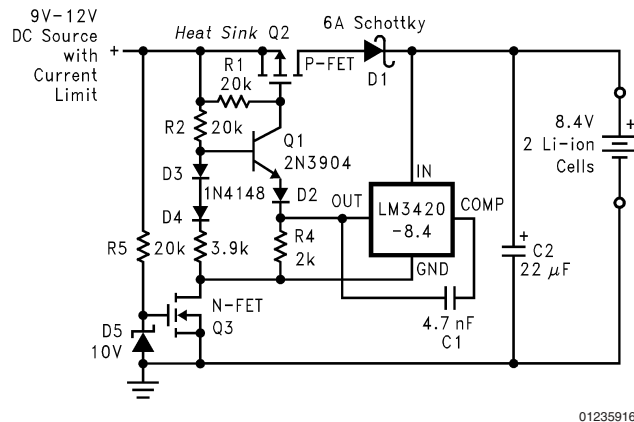

FIGURE 11. MOSFET Low Dropout Charger

Figure 11 shows a low dropout constant voltage charger using a MOSFET as the pass element, but this circuit does not include current limiting. This circuit uses Q3 and a Schottky diode to isolate the battery from the charging circuitry when the input voltage is removed, to prevent the battery from discharging. Q2 should be a high current (0.2Ω) FET, while Q3 can be a low current (2Ω) device.

Note: Although the application circuits shown here have been built and tested, they should be thoroughly evaluated with the same type of battery the charger will eventually be used with.

Different battery manufacturers may use a slightly different battery chemistry which may require different charging characteristics. Always consult the battery manufacturer for information on charging specifications and battery details, and always observe the manufacturer's precautions when using their batteries. Avoid overcharging or shorting Lithium-Ion batteries.

Physical Dimensions inches (millimeters) unless otherwise noted

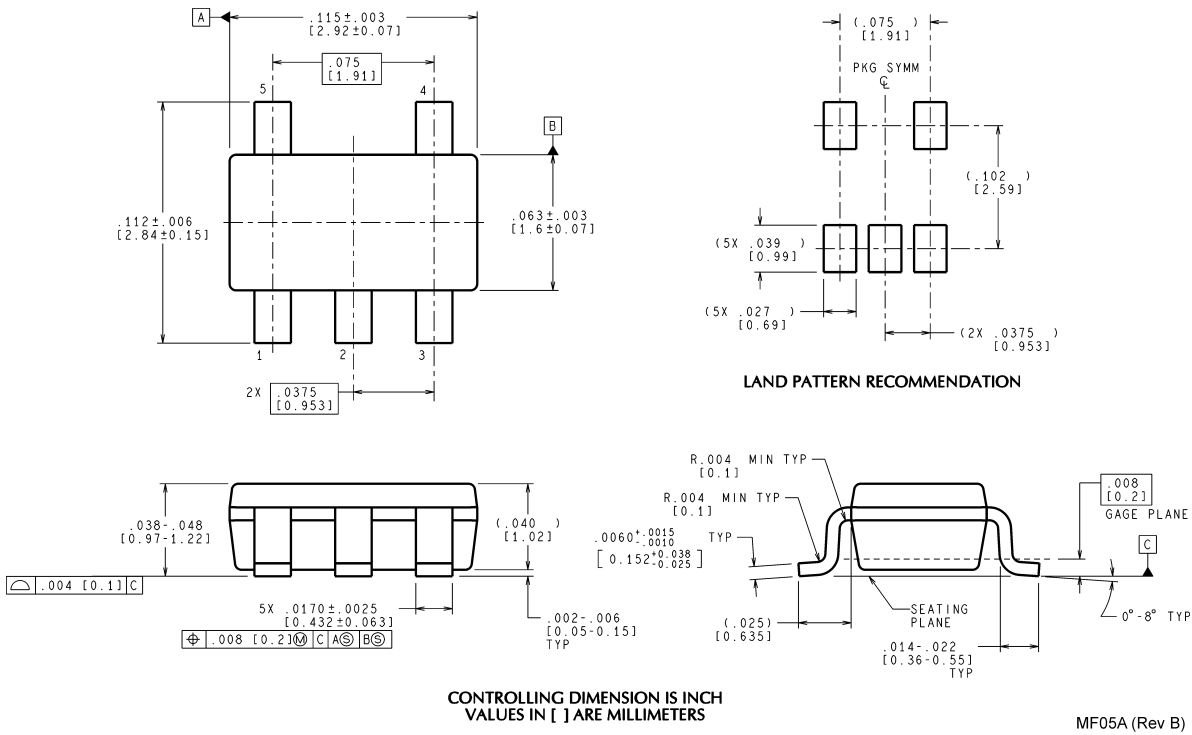

**5-Lead Small Outline Package (M5)
For Ordering Information See *Figure 1* In This Data Sheet
NS Package Number MF05A**

National does not assume any responsibility for use of any circuitry described, no circuit patent licenses are implied and National reserves the right at any time without notice to change said circuitry and specifications.

For the most current product information visit us at www.national.com.

LIFE SUPPORT POLICY

NATIONAL'S PRODUCTS ARE NOT AUTHORIZED FOR USE AS CRITICAL COMPONENTS IN LIFE SUPPORT DEVICES OR SYSTEMS WITHOUT THE EXPRESS WRITTEN APPROVAL OF THE PRESIDENT AND GENERAL COUNSEL OF NATIONAL SEMICONDUCTOR CORPORATION. As used herein:

1. Life support devices or systems are devices or systems which, (a) are intended for surgical implant into the body, or (b) support or sustain life, and whose failure to perform when properly used in accordance with instructions for use provided in the labeling, can be reasonably expected to result in a significant injury to the user.
2. A critical component is any component of a life support device or system whose failure to perform can be reasonably expected to cause the failure of the life support device or system, or to affect its safety or effectiveness.

BANNED SUBSTANCE COMPLIANCE

National Semiconductor certifies that the products and packing materials meet the provisions of the Customer Products Stewardship Specification (CSP-9-111C2) and the Banned Substances and Materials of Interest Specification (CSP-9-111S2) and contain no "Banned Substances" as defined in CSP-9-111S2.

National Semiconductor
Americas Customer
Support Center
Email: new.feedback@nsc.com
Tel: 1-800-272-9959

National Semiconductor
Europe Customer Support Center
Fax: +49 (0) 180-530 85 86
Email: europe.support@nsc.com
Deutsch Tel: +49 (0) 69 9508 6208
English Tel: +44 (0) 870 24 0 2171
Français Tel: +33 (0) 1 41 91 8790

National Semiconductor
Asia Pacific Customer
Support Center
Email: ap.support@nsc.com

National Semiconductor
Japan Customer Support Center
Fax: 81-3-5639-7507
Email: jpn.feedback@nsc.com
Tel: 81-3-5639-7560

IMPORTANT NOTICE

Texas Instruments Incorporated and its subsidiaries (TI) reserve the right to make corrections, modifications, enhancements, improvements, and other changes to its products and services at any time and to discontinue any product or service without notice. Customers should obtain the latest relevant information before placing orders and should verify that such information is current and complete. All products are sold subject to TI's terms and conditions of sale supplied at the time of order acknowledgment.

TI warrants performance of its hardware products to the specifications applicable at the time of sale in accordance with TI's standard warranty. Testing and other quality control techniques are used to the extent TI deems necessary to support this warranty. Except where mandated by government requirements, testing of all parameters of each product is not necessarily performed.

TI assumes no liability for applications assistance or customer product design. Customers are responsible for their products and applications using TI components. To minimize the risks associated with customer products and applications, customers should provide adequate design and operating safeguards.

TI does not warrant or represent that any license, either express or implied, is granted under any TI patent right, copyright, mask work right, or other TI intellectual property right relating to any combination, machine, or process in which TI products or services are used. Information published by TI regarding third-party products or services does not constitute a license from TI to use such products or services or a warranty or endorsement thereof. Use of such information may require a license from a third party under the patents or other intellectual property of the third party, or a license from TI under the patents or other intellectual property of TI.

Reproduction of TI information in TI data books or data sheets is permissible only if reproduction is without alteration and is accompanied by all associated warranties, conditions, limitations, and notices. Reproduction of this information with alteration is an unfair and deceptive business practice. TI is not responsible or liable for such altered documentation. Information of third parties may be subject to additional restrictions.

Resale of TI products or services with statements different from or beyond the parameters stated by TI for that product or service voids all express and any implied warranties for the associated TI product or service and is an unfair and deceptive business practice. TI is not responsible or liable for any such statements.

TI products are not authorized for use in safety-critical applications (such as life support) where a failure of the TI product would reasonably be expected to cause severe personal injury or death, unless officers of the parties have executed an agreement specifically governing such use. Buyers represent that they have all necessary expertise in the safety and regulatory ramifications of their applications, and acknowledge and agree that they are solely responsible for all legal, regulatory and safety-related requirements concerning their products and any use of TI products in such safety-critical applications, notwithstanding any applications-related information or support that may be provided by TI. Further, Buyers must fully indemnify TI and its representatives against any damages arising out of the use of TI products in such safety-critical applications.

TI products are neither designed nor intended for use in military/aerospace applications or environments unless the TI products are specifically designated by TI as military-grade or "enhanced plastic." Only products designated by TI as military-grade meet military specifications. Buyers acknowledge and agree that any such use of TI products which TI has not designated as military-grade is solely at the Buyer's risk, and that they are solely responsible for compliance with all legal and regulatory requirements in connection with such use.

TI products are neither designed nor intended for use in automotive applications or environments unless the specific TI products are designated by TI as compliant with ISO/TS 16949 requirements. Buyers acknowledge and agree that, if they use any non-designated products in automotive applications, TI will not be responsible for any failure to meet such requirements.

Following are URLs where you can obtain information on other Texas Instruments products and application solutions:

Products

Audio	www.ti.com/audio
Amplifiers	amplifier.ti.com
Data Converters	dataconverter.ti.com
DLP® Products	www.dlp.com
DSP	dsp.ti.com
Clocks and Timers	www.ti.com/clocks
Interface	interface.ti.com
Logic	logic.ti.com
Power Mgmt	power.ti.com
Microcontrollers	microcontroller.ti.com
RFID	www.ti-rfid.com
OMAP Mobile Processors	www.ti.com/omap
Wireless Connectivity	www.ti.com/wirelessconnectivity

Applications

Communications and Telecom	www.ti.com/communications
Computers and Peripherals	www.ti.com/computers
Consumer Electronics	www.ti.com/consumer-apps
Energy and Lighting	www.ti.com/energy
Industrial	www.ti.com/industrial
Medical	www.ti.com/medical
Security	www.ti.com/security
Space, Avionics and Defense	www.ti.com/space-avionics-defense
Transportation and Automotive	www.ti.com/automotive
Video and Imaging	www.ti.com/video

TI E2E Community Home Page

e2e.ti.com

Mailing Address: Texas Instruments, Post Office Box 655303, Dallas, Texas 75265
Copyright © 2011, Texas Instruments Incorporated

Looking for pricing, stock, or lifecycle information?

Click below to explore more details on WIN SOURCE:

 [View LM3420M5-12.6](#) on WIN SOURCE

 [Texas Instruments](#) Information

Optimize Your Supply Chain with WIN SOURCE Solutions

-  Global Sourcing Solution
-  Obsolete Management
-  Cost Control Management
-  Shortage Management
-  Alternative Solution
-  Excess Inventory Management