



THE DATASHEET OF AOZ1342PI



General Description

The AOZ1342 power-distribution switches is intended for applications where heavy capacitive loads and short-circuits are likely to be encountered. This device incorporates N-channel MOSFET power switches for power-distribution systems that require multiple power switches in a single package. Each switch is controlled by a logic enable input. Gate drive is provided by an internal charge pump designed to control the power-switch rise times and fall times to minimize current surges during switching. The charge pump requires no external components and allows operation from supplies as low as 2.7 V.

The AOZ1342 offers 1.5 A of maximum continuous current.

The AOZ1342 is available in an Exposed Pad SO-8 package and is rated over a -40 °C to +85 °C ambient temperature range.

Features

- Typical 70 mΩ (NFET)
- 1.5 A maximum continuous current
- Two enable options: EN or \overline{EN}
- Vin range: 2.7 V to 5.5 V
- Open Drain Fault Flag
- Fault Flag deglitched (blanking time)
- Thermal shutdown
- Reverse current blocking
- Exposed pad SO-8 package

Applications

- Notebook Computers
- Desktop Computers



Typical Application

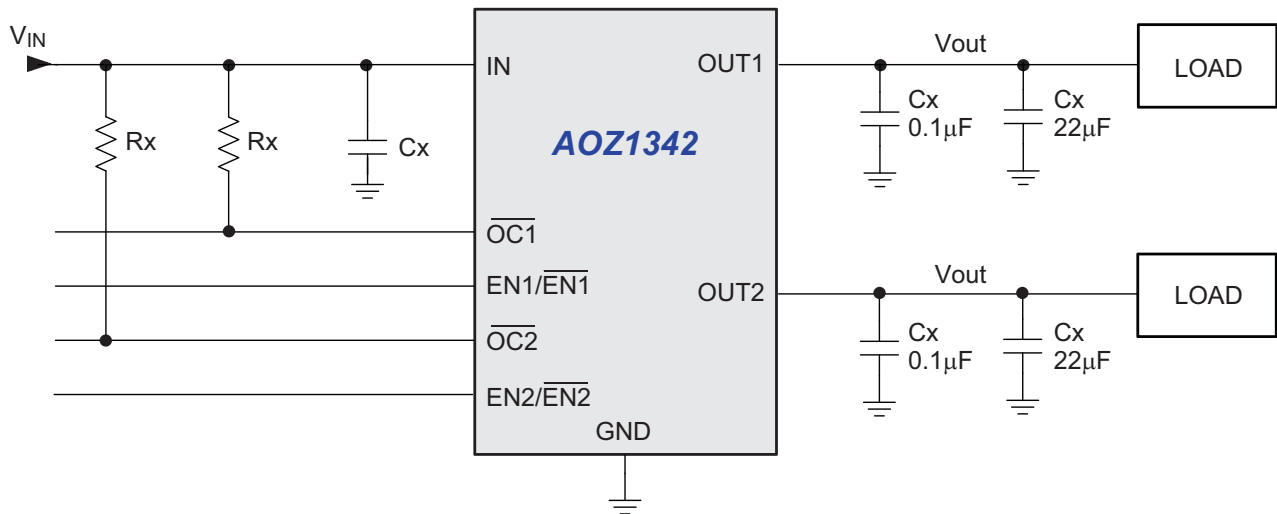

Ordering Information

Part Number	Maximum Continuous Current		Typical Short-circuit Current Limit		Enable Setting	Package	Output Discharge	Environmental
	Channel 1	Channel 2	Channel 1	Channel 2				
AOZ1341AI	1 A	1A	1.5 A	1.5 A	Active Low	SO-8	No	Green Product RoHS Compliant
AOZ1341EI						EPAD MSOP-8		
AOZ1341AI-1					Active High	SO-8		
AOZ1341EI-1						EPAD MSOP-8		
AOZ1342PI	1.5 A	1.5A	2 A	2 A	Active Low	EPAD SO-8		
AOZ1342PI-1					Active High	EPAD SO-8		
AOZ1343AI*	1.5 A	0.5A	2 A	0.75 A	Active Low	SO-8		
AOZ1343EI*						EPAD MSOP-8		
AOZ1343AI-1*					Active High	SO-8		
AOZ1343EI-1*						EPAD MSOP-8		
AOZ1312AI-1	1.5 A	None	2 A	None	Active High	SO-8		
AOZ1312EI-1						EPAD MSOP-8		
AOZ1310CI-1	0.5 A	None	0.75 A	None	Active High	SOT23-5		

*Contact factory for availability



AOS Green Products use reduced levels of Halogens, and are also RoHS compliant.

Please visit www.aosmd.com/web/quality/rohs_compliant.jsp for additional information.

Pin Configuration

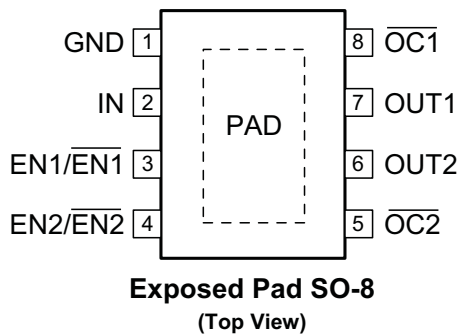

Pin Description

Pin Name	Pin Number	Pin Function
GND	1	Ground
IN	2	Input voltage
EN1/ $\overline{\text{EN1}}$	3	Enable input, logic high/logic low turns on power switch IN-OUT1
EN2/ $\overline{\text{EN2}}$	4	Enable input, logic high/logic low turns on power switch IN-OUT2
$\overline{\text{OC2}}$	5	Overcurrent, open-drain output, active low, IN-OUT1
OUT2	6	Power-switch output, IN-OUT1
OUT1	7	Power-switch output, IN-OUT2
$\overline{\text{OC1}}$	8	Overcurrent, open-drain output, active low, IN-OUT2

Absolute Maximum Ratings

Exceeding the Absolute Maximum Ratings may damage the device.

Parameter	Rating
Input Voltage (V_{IN})	6 V
Enable Voltage (V_{EN})	6 V
Storage Temperature (T_S)	-55 °C to +150 °C
Maximum Continuous Current	1.5 A
ESD Rating ⁽¹⁾	2 kV

Note:

1. Devices are inherently ESD sensitive, handling precautions are required. Human body model is a 100 pF capacitor discharging through a 1.5 kΩ resistor.

Recommended Operating Conditions

The device is not guaranteed to operate beyond the Recommended Operating Conditions.

Parameter	Rating
Input Voltage (V_{IN})	+2.7 V to +5.5 V
Junction Temperature (T_J)	-40 °C to +125 °C
Package Thermal Resistance Exposed Pad SO-8 (θ_{JA})	45 °C/W

Electrical Characteristics

$T_A = 25\text{ °C}$, $V_{IN} = V_{EN} = 5.5\text{ V}$, unless otherwise specified.

Symbol	Parameter	Conditions	Min.	Typ.	Max.	Units
POWER SWITCH						
$R_{DS(ON)}$	Switch On-Resistance	$V_{IN} = 2.7\text{ V to } 5\text{ V}$, $I_O = 0.5\text{ A/1.5 A}$		70	135	mΩ
t_r	Rise Time, Output	$V_{IN} = 5.5\text{ V}$		0.6	1.5	ms
		$V_{IN} = 2.7\text{ V}$				
t_f	Fall time, Output	$V_{IN} = 5.5\text{ V}$		0.05	0.5	ms
		$V_{IN} = 2.7\text{ V}$				
	FET Leakage Current	Out connect to ground, $2.7\text{ V} \leq V_{IN} \leq 5.5\text{ V}$, $V_{(\overline{ENx})} = V_{IN}$ or $V_{(ENx)} = 0\text{ V}$	$-40\text{ °C} \leq T_J \leq 125\text{ °C}^{(2)}$	1		μA
ENABLE INPUT EN OR EN						
V_{IH}	High-level Input Voltage	$2.7\text{ V} \leq V_{IN} \leq 5.5\text{ V}$	2.0			V
V_{IL}	Low-level Input Voltage	$2.7\text{ V} \leq V_{IN} \leq 5.5\text{ V}$			0.8	V
I_I	Input Current		-0.5		0.5	μA
t_{on}	Turn-on Time	$C_L = 100\text{ μF}$, $R_L = 5\text{ Ω}$			3	ms
t_{off}	Turn-off Time	$C_L = 100\text{ μF}$, $R_L = 5\text{ Ω}$			10	ms
CURRENT LIMIT						
I_{OS}	Short-circuit Output Current (per Channel)	$V_{(IN)} = 2.7\text{ V to } 5.5\text{ V}$, OUT connected to GND, device enable into short-circuit, Channel 1 or 2	1.6	2.0	2.4	A
I_{OC_TRIP}	Overcurrent Trip Threshold (per Channel)	$V_{(IN)} = 5\text{ V}$, current ramp ($\leq 100\text{ A/s}$) on OUT, Channel 1 or 2	1.6	2.2	2.5	A
SUPPLY CURRENT						
	Supply Current, Low-level Output	No load on OUT, $2.7\text{ V} \leq V_{IN} \leq 5.5\text{ V}$, $V_{(\overline{ENx})} = V_{IN}$ or $V_{(ENx)} = 0\text{ V}$	$T_J = 25\text{ °C}$	0.5	1	μA
			$-40\text{ °C} \leq T_J \leq 125\text{ °C}^{(2)}$	0.5	5	
	Supply current, High-level Output	No load on OUT, $V_{(\overline{ENx})} = 0\text{ V}$ or $V_{(ENx)} = 5.5\text{ V}$	$T_J = 25\text{ °C}$	65	81	μA
			$-40\text{ °C} \leq T_J \leq 125\text{ °C}^{(2)}$	65	90	
	Reverse Leakage Current	$V_{(OUTx)} = 5.5\text{ V}$, IN = ground		0.2		μA

Electrical Characteristics (Continued)

 $T_A = 25\text{ }^\circ\text{C}$, $V_{IN} = V_{EN} = 5.5\text{ V}$, unless otherwise specified.

Symbol	Parameter	Conditions	Min.	Typ.	Max.	Units
UNDERVOLTAGE LOCKOUT						
	Low-level voltage, IN		2.0		2.5	V
	Hysteresis, IN			200		mV
OVERCURRENT OC1 AND OC2						
	Output Low Voltage $V_{OL(OCx)}$	$I_{O(OCx)} = 5\text{ mA}$			0.4	V
	Off-state Current	$V_{O(OCx)} = 5\text{ V or } 3.3\text{ V}$			1	μA
	OC_L Deglitch	OCx assertion or deassertion	4	8	15	ms
THERMAL SHUTDOWN						
	Thermal Shutdown Threshold		135			$^\circ\text{C}$
	Recovery from Thermal Shutdown		105			$^\circ\text{C}$
	Hysteresis			30		$^\circ\text{C}$

Note:

2. Parameters are guaranteed by design only and not production tested.

Functional Block Diagram

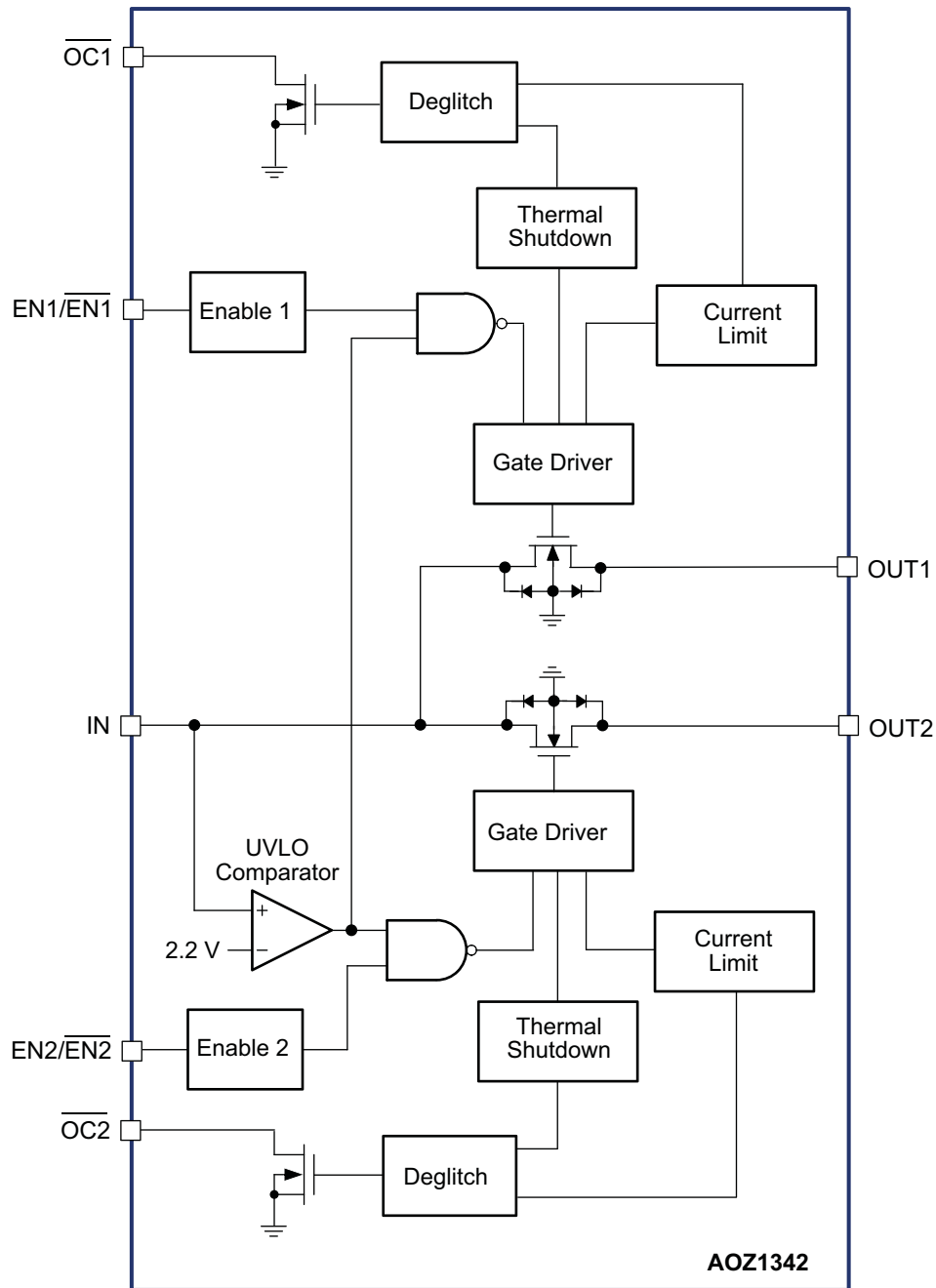

AOZ1342

Functional Characteristics

Figure 1. Turn-On Delay and Rise Time with 1 μ F Load (Active High)

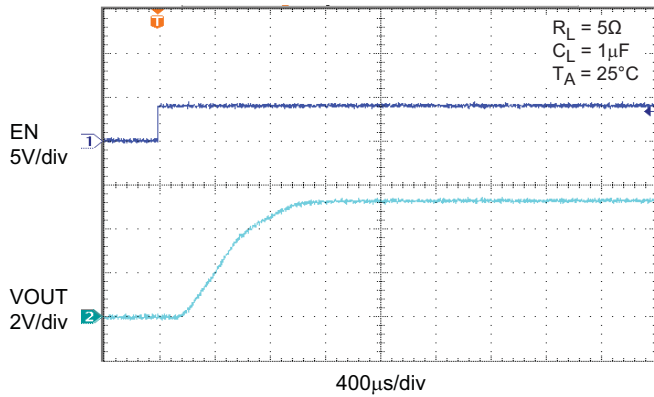

Figure 2. Turn-Off Delay and Fall Time with 1 μ F Load (Active High)

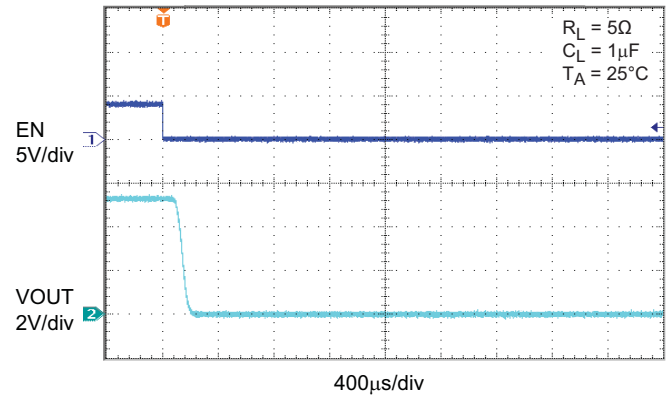

Figure 3. Turn-On Delay and Rise Time with 100 μ F Load (Active High)

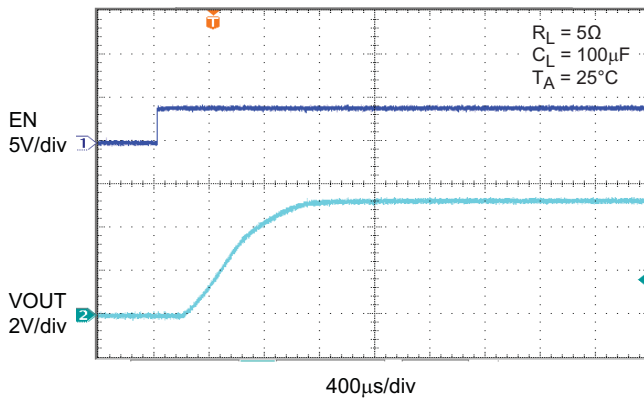

Figure 4. Turn-Off Delay and Fall Time with 100 μ F Load (Active High)

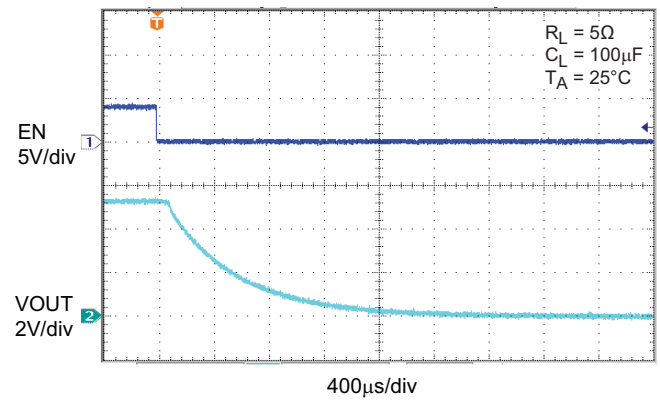

Figure 5. Short-circuit Current, Device Enable to Short (Active High)

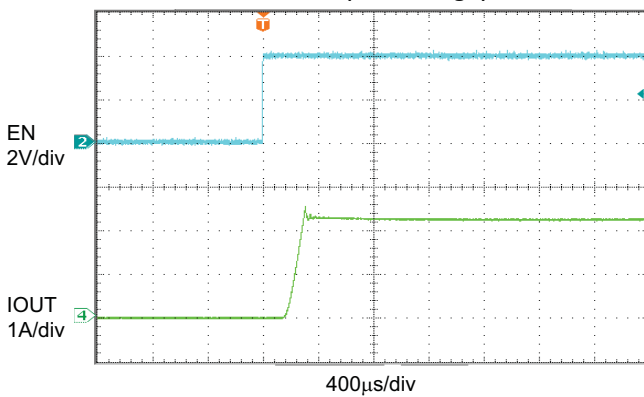
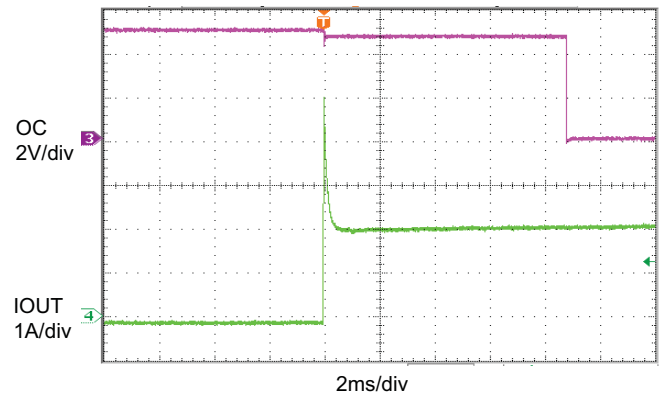

Figure 6. 0.6 Ω Load Connected to Enable to Device (Active High)



Typical Characteristics

Figure 7. Supply Current, Output Enabled vs. Junction Temperature

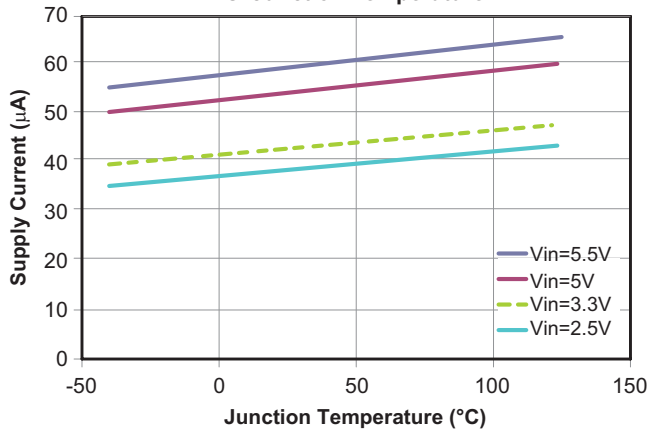

Figure 8. Supply Current, Output Disabled vs. Junction Temperature

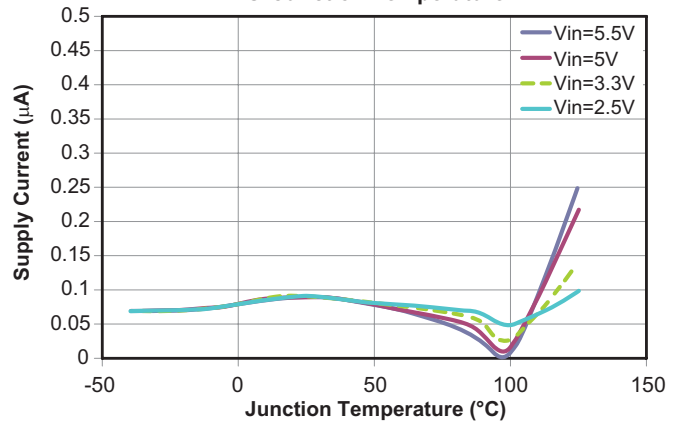

Figure 9. Rds(on) vs. Ambient Temperature

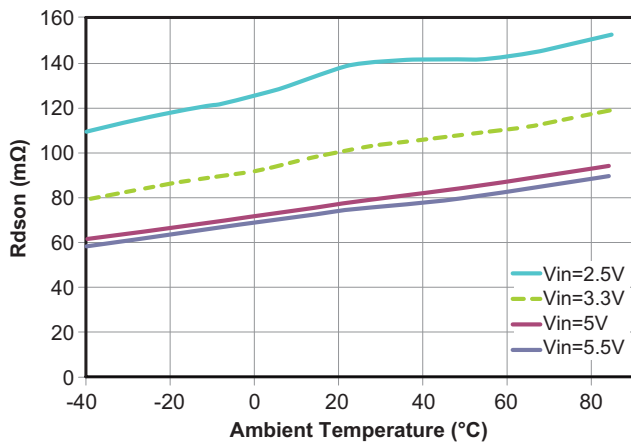
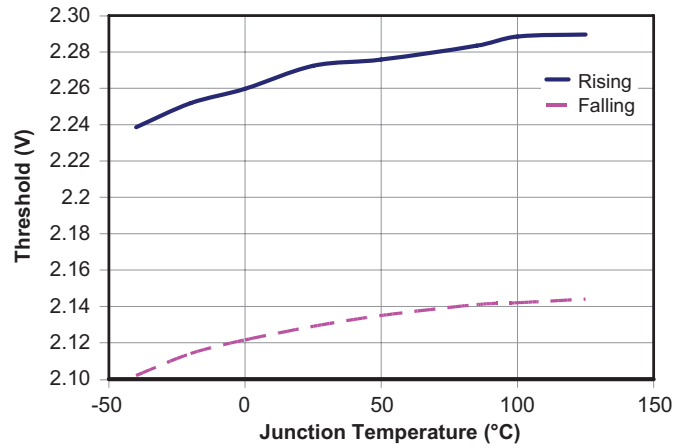

Figure 10. UVLO Threshold vs. Junction Temperature



Detailed Description

The AOZ1342 family of power-distribution switches are intended for applications where heavy capacitive loads and short-circuits are likely to be encountered. This device incorporates 70 mΩ N-channel MOSFET power switches for power-distribution systems that require multiple power switches in a single package. Each switch is controlled by a logic enable input. Gate drive is provided by an internal charge pump designed to control the power-switch rise times and fall times to minimize current surges during switching. The charge pump requires no external components and allows operation from supplies as low as 2.7 V.

Thermal Shut-down Protection

When the output load exceeds the current-limit threshold or a short is present, the device limits the output current to a safe level by switching into a constant-current mode, pulling the overcurrent (OC) logic output low.

During current limit or short circuit conditions, the increasing power dissipation in the chip causes the die temperature to rise. When the die temperature reaches a certain level, the thermal shutdown circuitry will shutdown the device. The thermal shutdown will cycle repeatedly until the short circuit condition is resolved.

Applications Information

Input Capacitor Selection

The input capacitor prevents large voltage transients from appearing at the input, and provides the instantaneous current needed each time the switch turns on and to also limit input voltage drop. The input capacitor also prevents high-frequency noise on the power line from passing through the output of the power side. The choice of input capacitor is based on its ripple current and voltage ratings rather than its capacitor value. The input capacitor should be located as close as possible to the VIN pin. A 0.1 μF ceramic cap is recommended. However, a higher value capacitor will reduce the voltage drop at the input.

Output Capacitor Selection

The output capacitor acts in a similar way. A small 0.1 μF capacitor prevents high-frequency noise from going into the system. Also, the output capacitor has to supply enough current for the large load that it may encounter during system transients. This bulk capacitor must be large enough to supply a fast transient load in order to prevent the output from dropping.

Power Dissipation Calculation

Calculate the power dissipation for normal load condition using the following equation:

$$P_D = R_{ON} \times (I_{OUT})^2$$

The worst case power dissipation occurs when the load current hits the current limit due to over-current or short circuit faults. The power dissipation under these conditions can be calculated using the following equation:

$$P_D = (V_{IN} - V_{OUT}) \times I_{LIMIT}$$

Layout Guidelines

Good PCB layout is important for improving the thermal and overall performance of AOZ1342. To optimize the switch response time to output short-circuit conditions, keep all traces as short as possible to reduce the effect of unwanted parasitic inductance. Place the input and output bypass capacitors as close as possible to the IN and OUT pins. The input and output PCB traces should be as wide as possible for the given PCB space. Use a ground plane to enhance the power dissipation capability of the device.

USB Power Distribution Application

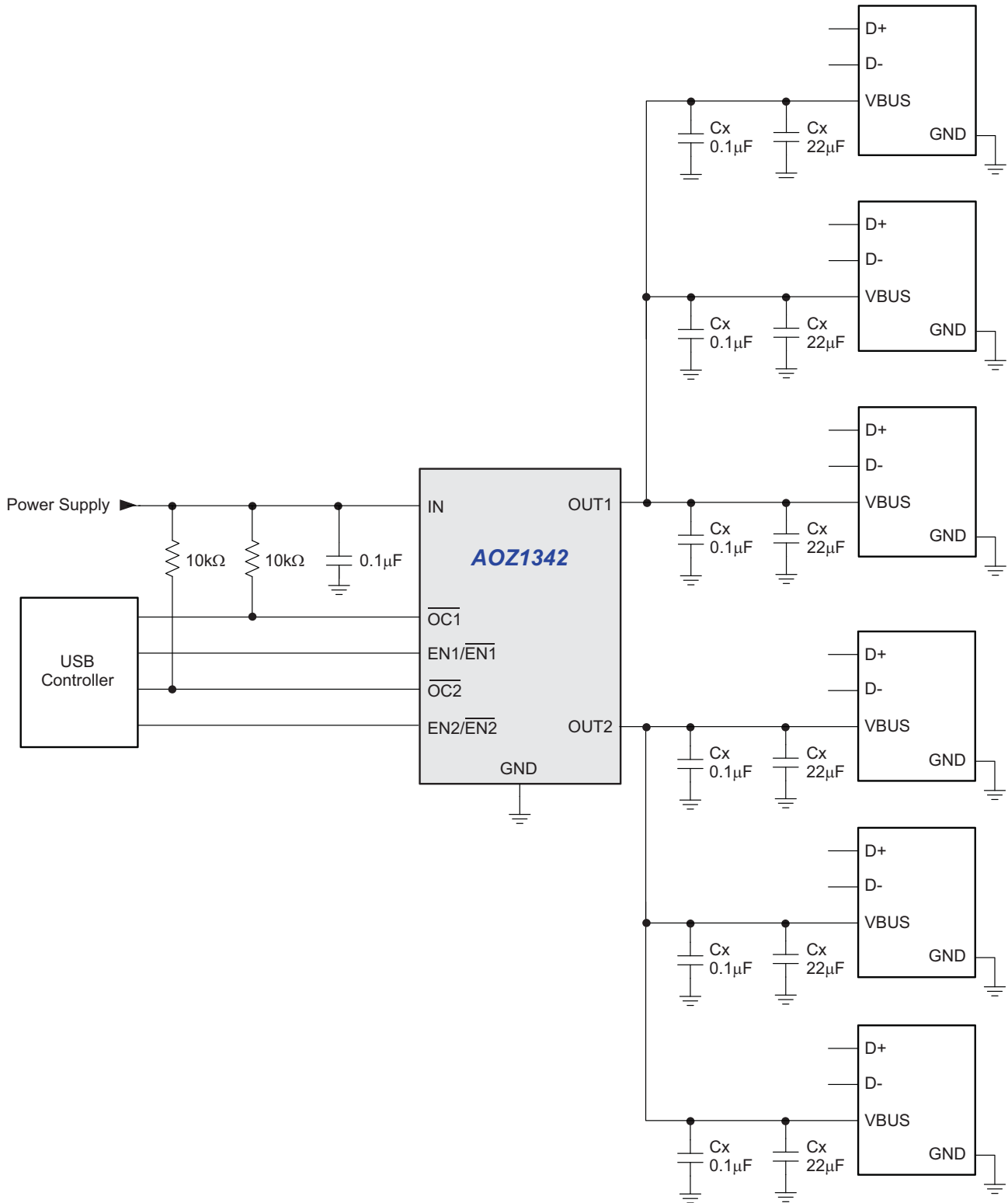
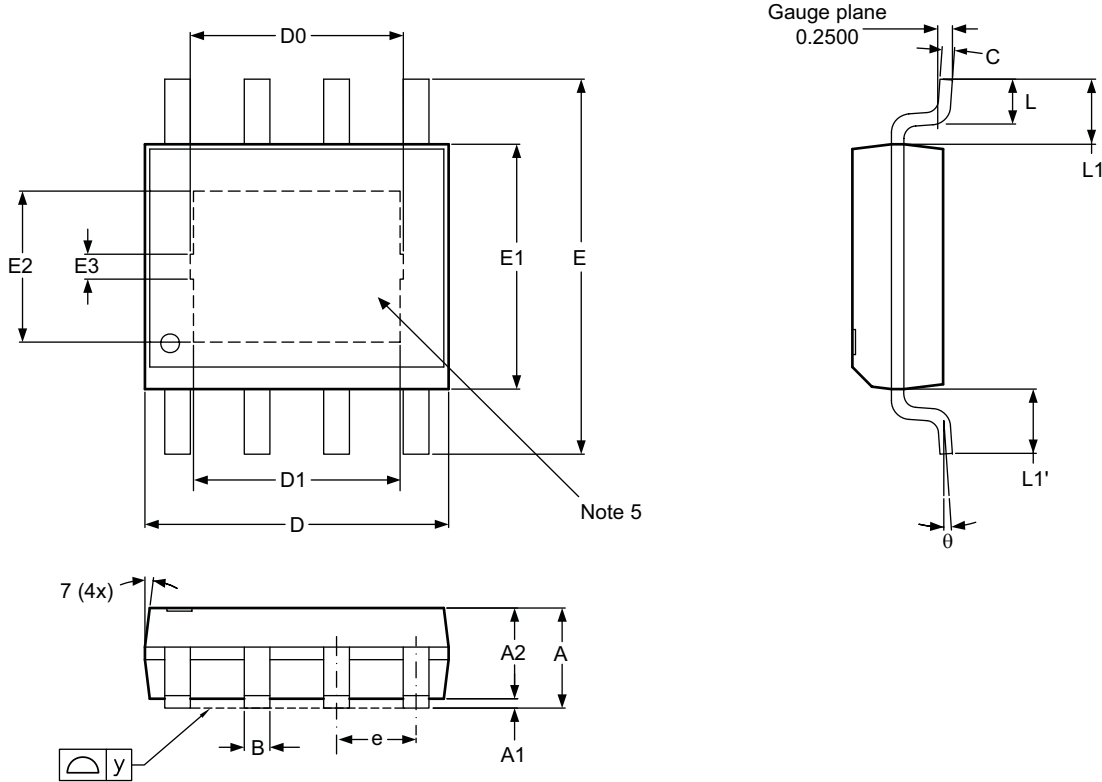
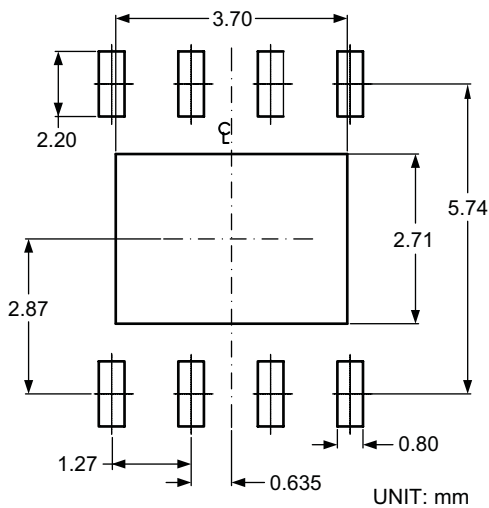

Figure 11. Typical Six-Port USB Host/Self-Powered Hub Applications Circuitry

Package Dimensions, Exposed Pad SO-8



RECOMMENDED LAND PATTERN



Dimensions in millimeters

Symbols	Min.	Nom.	Max.
A	1.40	1.55	1.70
A1	0.00	0.05	0.10
A2	1.40	1.50	1.60
B	0.31	0.406	0.51
C	0.17	—	0.25
D	4.80	4.96	5.00
D0	3.20	3.40	3.60
D1	3.10	3.30	3.50
E	5.80	6.00	6.20
e	—	1.27	—
E1	3.80	3.90	4.00
E2	2.21	2.41	2.61
E3	0.40 REF		
L	0.40	0.95	1.27
y	—	—	0.10
θ	0°	3°	8°
L1-L1'	—	0.04	0.12
L1	1.04 REF		

Dimensions in inches

Symbols	Min.	Nom.	Max.
A	0.055	0.061	0.067
A1	0.000	0.002	0.004
A2	0.055	0.059	0.063
B	0.012	0.016	0.020
C	0.007	—	0.010
D	0.189	0.195	0.197
D0	0.126	0.134	0.142
D1	0.122	0.130	0.138
E	0.228	0.236	0.244
e	—	0.050	—
E1	0.150	0.153	0.157
E2	0.087	0.095	0.103
E3	0.016 REF		
L	0.016	0.037	0.050
y	—	—	0.004
θ	0°	3°	8°
L1-L1'	—	0.002	0.005
L1	0.041 REF		

Notes:

1. Package body sizes exclude mold flash and gate burrs.
2. Dimension L is measured in gauge plane.
3. Tolerance 0.10mm unless otherwise specified.
4. Controlling dimension is millimeter, converted inch dimensions are not necessarily exact.
5. Die pad exposure size is according to lead frame design.
6. Followed from JEDEC MS-012

Tape and Reel Dimensions, Exposed Pad SO-8

Carrier Tape

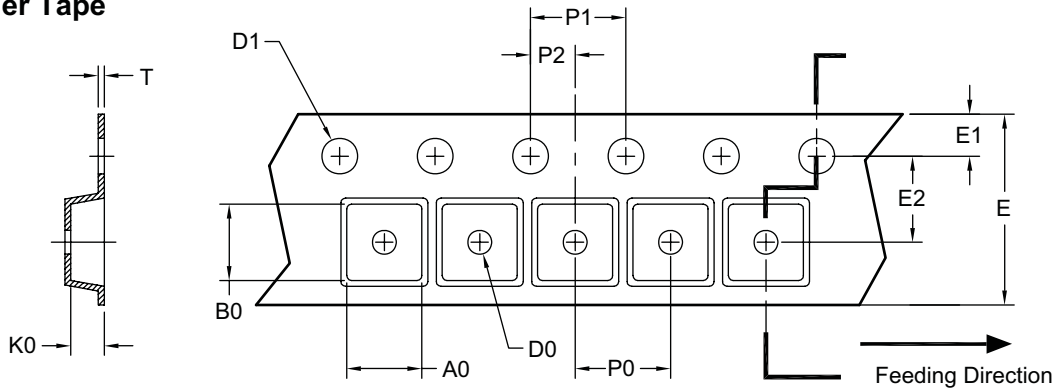

UNIT: mm

Package	A0	B0	K0	D0	D1	E	E1	E2	P0	P1	P2	T
SO-8 (12mm)	6.40 ±0.10	5.20 ±0.10	2.10 ±0.10	1.60 ±0.10	1.50 ±0.10	12.00 ±0.10	1.75 ±0.10	5.50 ±0.10	8.00 ±0.10	4.00 ±0.10	2.00 ±0.10	0.25 ±0.10

Reel

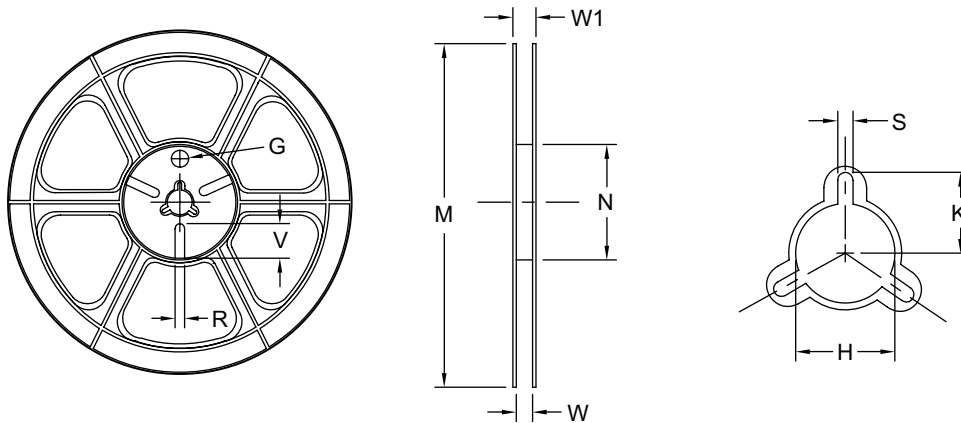

UNIT: mm

Tape Size	Reel Size	M	N	W	W1	H	K	S	G	R	V
12mm	ø330	ø330.00 ±0.50	ø97.00 ±0.10	13.00 ±0.30	17.40 ±1.00	ø13.00 +0.50/-0.20	10.60	2.00 ±0.50	—	—	—

Leader/Trailer and Orientation

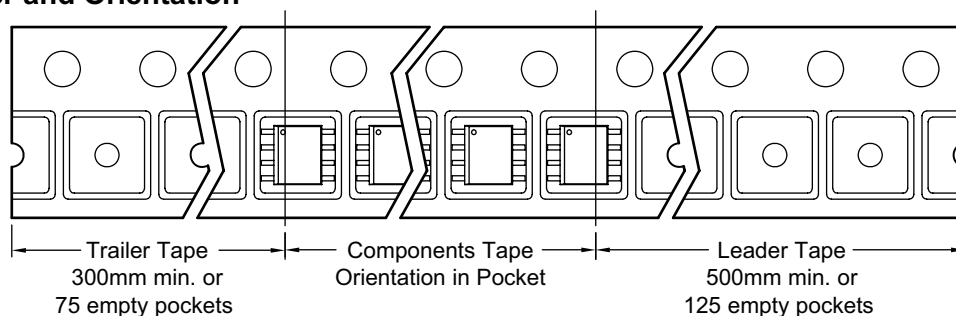

Part Marking

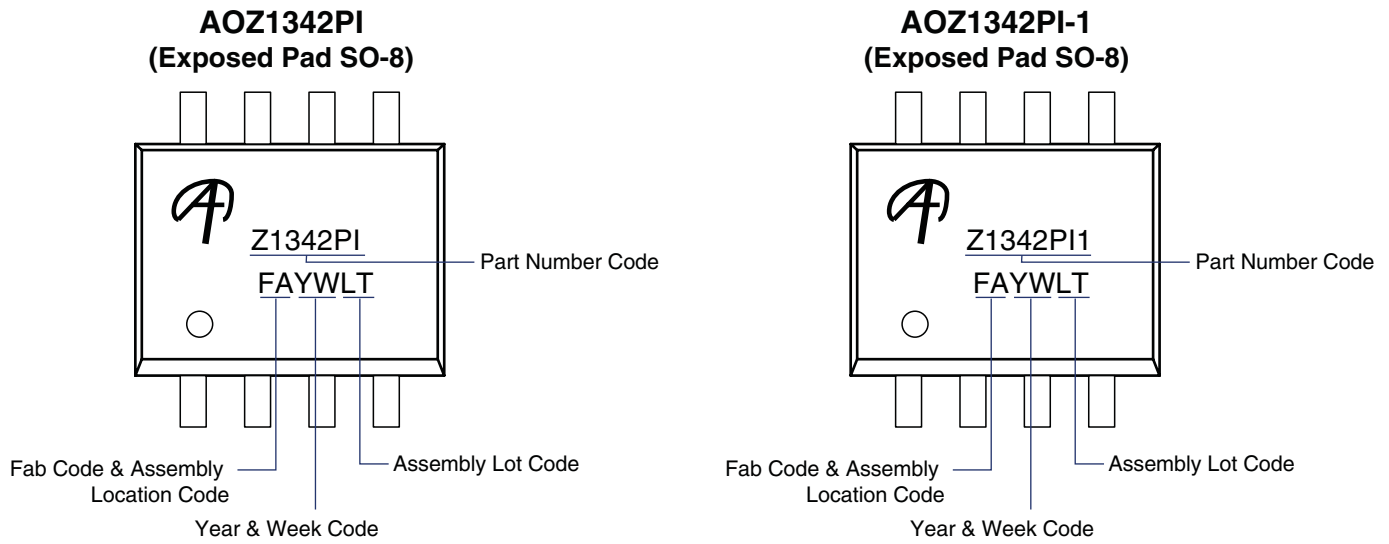

This datasheet contains preliminary data; supplementary data may be published at a later date. Alpha & Omega Semiconductor reserves the right to make changes at any time without notice.

LIFE SUPPORT POLICY

ALPHA & OMEGA SEMICONDUCTOR PRODUCTS ARE NOT AUTHORIZED FOR USE AS CRITICAL COMPONENTS IN LIFE SUPPORT DEVICES OR SYSTEMS.

As used herein:

1. Life support devices or systems are devices or systems which, (a) are intended for surgical implant into the body or (b) support or sustain life, and (c) whose failure to perform when properly used in accordance with instructions for use provided in the labeling, can be reasonably expected to result in a significant injury of the user.
2. A critical component in any component of a life support, device, or system whose failure to perform can be reasonably expected to cause the failure of the life support device or system, or to affect its safety or effectiveness.

Looking for pricing, stock, or lifecycle information?

Click below to explore more details on WIN SOURCE:

- ⊖ [View AOZ1342PI on WIN SOURCE](#)
- ⊖ [Alpha & Omega Semiconductor Inc. Information](#)

Optimize Your Supply Chain with WIN SOURCE Solutions

- ✓ Global Sourcing Solution
- ✓ Obsolete Management
- ✓ Cost Control Management
- ✓ Shortage Management
- ✓ Alternative Solution
- ✓ Excess Inventory Management