Multi-Channel High Definition Audio Codec

DESCRIPTION

The WM8850 is a high performance multi-channel audio CODEC designed for high performance PC audio systems. The device offers full compatibility with the Intel High Definition Audio (HDA) specification revision 1.0, allowing seamless integration with industry-standard HDA controllers.

The WM8850 has three high performance stereo DACs to enable six channels of high definition audio, ideal for 5.1 channel applications. A high-performance ground-referenced stereo headphone amplifier utilises advanced charge pump and DC servo technology to minimise system cost and space without compromise on audio quality. Line outputs provide a high-quality differential connection to speaker amplifiers, enabling common mode noise rejection when these traces are routed across a PCB.

The WM8850 also has two high performance stereo ADCs to provide Hi-Fi quality analogue line-in and microphone input digitisation. A low noise microphone bias with programmable output voltage is provided. Additionally, the CODEC contains a digital microphone interface capable of supporting up to four independent digital microphones. One differential stereo input is provided for line level signals, while one pseudo-differential stereo input with integrated microphone preamplifier is provided.

The WM8850 also contains a S/PDIF transceiver which is fully compatible with IEC-60958-3. The S/PDIF receive and transmit paths each contain a sample rate converter (SRC) to enable asynchronous sample rate conversion between the S/PDIF receive/transmit and HDA interface clock domains. An additional S/PDIF transmitter is provided to allow direct output of a stereo stream from the HDA interface.

The WM8850 is supplied in a small 48-pin QFN package.

FEATURES

- Multi-channel High Definition Audio CODEC
- Fully compatible with Intel High Definition Audio Revision 1.0
- 6-Channel DAC, 4-channel ADC
- DAC sampling frequency 8kHz - 192kHz
- ADC sampling frequency 8kHz - 96kHz
- DAC Performance:
 - SNR 108 dB ('A' weighted)
 - SNR 105dB (non weighted)
 - THD -96dB (at 0dBFS)
- ADC Performance:
 - SNR 105 dB ('A' weighted)
 - SNR 102dB (non weighted)
 - THD -95dB (at -1dBFS)
- Ground-referenced stereo headphone driver
- Differential line inputs/outputs
- Stereo microphone interface with integrated pre-amp
- Multi-channel digital microphone interface
- IEC-60958-3 compatible S/PDIF transceiver
- Additional IEC-60958-3 compatible S/PDIF transmitter
- Jack detect and load impedance sensing
- Beep generator
- GPIO functionality
- IEEE-754 Single precision 32-bit floating point support
- Power supplies
 - Digital core: 1.62V – 1.98V
 - Digital buffer: 2.97V – 3.63V
 - Analogue: 4.5V – 5.25V
 - Charge pump: 4.5V – 5.25V
- 48-pin 7mm x 7mm QFN package

APPLICATIONS

- High performance PC audio
- All-in-one desktop PC
- Notebook PC

BLOCK DIAGRAM

TABLE OF CONTENTS

DESCRIPTION	1
FEATURES	1
APPLICATIONS	1
BLOCK DIAGRAM	2
TABLE OF CONTENTS	3
PIN CONFIGURATION	9
ORDERING INFORMATION	9
PIN DESCRIPTION	10
ABSOLUTE MAXIMUM RATINGS	11
RECOMMENDED OPERATING CONDITIONS	11
THERMAL PERFORMANCE	12
ELECTRICAL CHARACTERISTICS	13
TERMINOLOGY	25
POWER CONSUMPTION	26
SIGNAL TIMING REQUIREMENTS	27
INTERNAL POWER ON RESET CIRCUIT	28
INTRODUCTION	29
CIRRUS LOGIC INTERPRETATION OF HDA SPECIFICATION	29
DOLBY AC3 (IEC-61937)	29
FLOAT32	29
AUDIO WIDGETS CAPABILITIES PARAMETER: DIGITAL	30
LATENCY	30
POWER STATES	30
STREAM START/STOP	31
SDI STREAM ORDER.....	31
BANDWIDTH CONFLICTS.....	32
SOFTWARE FORMATTED (RAW) S/PDIF	32
SOURCE SYNCHRONOUS INPUT - S/PDIF RX.....	32
S/PDIF TX VALIDITY FLAG	33
CHANNEL NUMBERING.....	33
ILLEGAL REGISTER VALUES.....	34
RESPONSE FIELD.....	34
CHIP HIERARCHY	35
WIDGET DIAGRAM.....	35
NODE LIST.....	36
NODE/VERB SUMMARY	37
DEVICE DESCRIPTION	39
STEREO ANALOGUE LINE RECORD	40
PORT-E (NID = 0CH)	40
PGA1 (NID = 0AH).....	41
ADC1 (NID = 02H)	42
STEREO ANALOGUE MICROPHONE RECORD	44
PORT-B (NID = 0DH)	44
PGA2 (NID = 0BH).....	46
MIC1 MUX (NID = 09H)	47
MIC1 (NID = 03H)	47
DIGITAL MICROPHONE RECORD	49
PORT-D (NID = 0EH)	50
PORT-H (NID = 16H).....	50

MIC2 (NID = 15H)	51
DIGITAL MICROPHONE INTERFACE CLOCK RATES	51
STEREO HEADPHONE PLAYBACK	52
DAC1 (NID = 06H)	52
PORT-A (NID = 11H)	54
STEREO LINE PLAYBACK.....	55
DAC2 (NID = 07H) AND DAC3 (NID = 08H).....	55
PORT-G (NID = 12H) AND PORT-F (NID = 13H)	57
S/PDIF RECEIVE	58
S/PDIF IN (NID = 10H)	58
S/PDIF RX (NID = 05H)	61
S/PDIF RECEIVE USING SRC1	64
S/PDIF RECEIVE WITHOUT USING SRC1	64
S/PDIF RECEIVE TO DACS	65
S/PDIF TRANSMIT	66
S/PDIF TX 1 (NID = 04H)	67
S/PDIF OUT (NID = 0FH)	69
S/PDIF TRANSMIT USING SRC2	70
S/PDIF TRANSMIT WITHOUT USING SRC2	71
S/PDIF TX 2 (NID = 17H)	72
ANCILLARY FUNCTIONS.....	74
BEEP (NID = 14H)	74
AUDIO FUNCTION GROUP (NID = 01H).....	74
UNSOLICITED RESPONSES	77
GENERATING UNSOLICITED RESPONSES	77
PRIORITY QUEUING	77
IN-QUEUE-UPDATE.....	77
UNSOLICITED RESPONSE TYPES	79
SF = UNSOLICITED RESPONSE STATUS FLAG	79
UF = UNSOLICITED RESPONSE UPDATE FLAG.....	79
EF = UNSOLICITED RESPONSE EVENT FLAG.....	79
UNSOLICITED RESPONSE DEFINITIONS	80
DETAILED VERB DESCRIPTIONS	87
ROOT NODE (NID = 00H)	87
AUDIO FUNCTION GROUP (NID = 01H)	89
FUNCTION RESET VERB.....	89
GET PARAMETER VERB	89
POWER STATE VERB.....	91
UNSOLICITED RESPONSE VERB.....	91
GPIO DATA VERB	92
GPIO ENABLE MASK VERB.....	92
GPIO DIRECTION VERB	92
GPIO WAKE ENABLE MASK VERB	92
GPIO UNSOLICITED ENABLE MASK VERB	93
GPIO STICKY MASK VERB	93
IMPLEMENTATION ID / SUBSYSTEM ID VERB.....	93
VMID CONTROL VERB (VENDOR SPECIFIC)	94
GPIO AUTOMATIC CONTROL VERB (VENDOR-SPECIFIC).....	94
UNSOLICITED RESPONSE PRIORITY CONTROL VERB (VENDOR-SPECIFIC).....	95
ADC1 AUDIO INPUT CONVERTER WIDGET (NID = 02H).....	97
STREAM FORMAT VERB	97
GET PARAMETER VERB	98
GET CONNECTION LIST ENTRY VERB.....	99
PROCESSING STATE VERB	100

POWER STATE VERB	100
CONVERTER STREAM, CHANNEL VERB	100
UNSOLICITED RESPONSE VERB	101
UNSOLICITED RESPONSE PRIORITY CONTROL VERB (VENDOR-SPECIFIC)	101
CHANNEL COPY VERB (VENDOR-SPECIFIC)	101
MIC1 AUDIO INPUT CONVERTER WIDGET (NID = 03H).....	103
STREAM FORMAT VERB	103
GET PARAMETER VERB	104
GET CONNECTION LIST ENTRY VERB	105
PROCESSING STATE VERB	106
POWER STATE VERB	106
CONVERTER STREAM, CHANNEL VERB	107
UNSOLICITED RESPONSE VERB	107
UNSOLICITED RESPONSE PRIORITY CONTROL VERB (VENDOR-SPECIFIC)	107
CHANNEL COPY VERB (VENDOR-SPECIFIC)	108
S/PDIF TX 1 AUDIO OUTPUT CONVERTER WIDGET (NID = 04H)	109
STREAM FORMAT VERB	109
GET PARAMETER VERB	110
PROCESSING STATE VERB	111
CONVERTER STREAM, CHANNEL VERB	112
UNSOLICITED RESPONSE VERB	112
S/PDIF CONVERTER CONTROL VERB	113
INTERNAL PATH VERB (VENDOR-SPECIFIC)	114
S/PDIF VERB (VENDOR-SPECIFIC)	114
TX CHANNEL STATUS CONTROL VERB (VENDOR-SPECIFIC)	115
CHANNEL STATUS DATA PACKING CONFIGURATION VERB (VENDOR-SPECIFIC)	115
UNSOLICITED RESPONSE PRIORITY CONTROL VERB (VENDOR-SPECIFIC)	116
S/PDIF RX AUDIO INPUT CONVERTER WIDGET (NID = 05H)	117
STREAM FORMAT VERB	117
GET PARAMETER VERB	118
GET CONNECTION LIST ENTRY VERB	119
PROCESSING STATE VERB	119
CONVERTER STREAM, CHANNEL VERB	120
UNSOLICITED RESPONSE VERB	120
DIGITAL CONVERTER CONTROL VERB	121
S/PDIF VERB (VENDOR-SPECIFIC)	121
UNSOLICITED RESPONSE PRIORITY CONTROL VERB (VENDOR-SPECIFIC)	122
GET CHANNEL STATUS VERB (VENDOR-SPECIFIC)	122
GET NON-AUDIO FLAG VERB (VENDOR-SPECIFIC)	122
OVERWRITE CONTROL VERB (VENDOR-SPECIFIC)	123
DAC1 AUDIO OUTPUT CONVERTER WIDGET (NID = 06H).....	125
STREAM FORMAT VERB	125
AMPLIFIER GAIN/MUTE VERB	126
GET PARAMETER VERB	127
POWER STATE VERB	128
CONVERTER STREAM, CHANNEL VERB	128
UNSOLICITED RESPONSE VERB	129
INTERNAL PATH VERB (VENDOR-SPECIFIC)	129
UNSOLICITED RESPONSE PRIORITY CONTROL VERB (VENDOR-SPECIFIC)	129
DAC2 AUDIO OUTPUT CONVERTER WIDGET (NID = 07H).....	131
STREAM FORMAT VERB	131
AMPLIFIER GAIN/MUTE VERB	132
GET PARAMETER VERB	133
POWER STATE VERB	134
CONVERTER STREAM, CHANNEL VERB	134

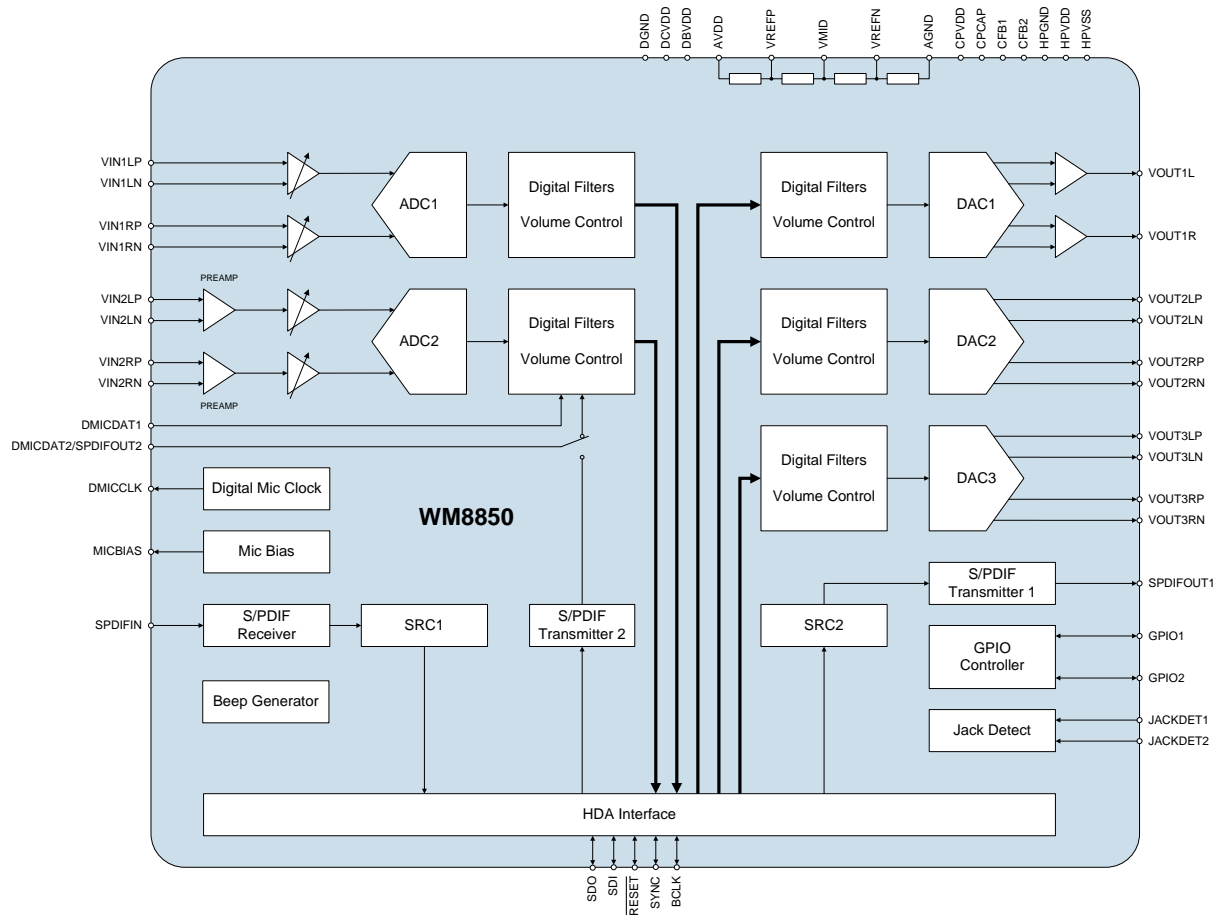
UNSOLICITED RESPONSE VERB	135
INTERNAL PATH VERB (VENDOR-SPECIFIC)	135
UNSOLICITED RESPONSE PRIORITY CONTROL VERB (VENDOR-SPECIFIC)	135
DAC3 AUDIO OUTPUT CONVERTER WIDGET (NID = 08H)	137
STREAM FORMAT VERB	137
AMPLIFIER GAIN/MUTE VERB	138
GET PARAMETER VERB	139
POWER STATE VERB	140
CONVERTER STREAM, CHANNEL VERB	140
UNSOLICITED RESPONSE VERB	141
INTERNAL PATH VERB (VENDOR-SPECIFIC)	141
UNSOLICITED RESPONSE PRIORITY CONTROL VERB (VENDOR-SPECIFIC)	141
MIC1 MUX SELECTOR WIDGET (NID = 09H)	143
GET PARAMETER VERB	143
CONNECTION SELECT CONTROL VERB	143
GET CONNECTION LIST ENTRY VERB	144
PGA1 SELECTOR WIDGET (NID = 0AH)	145
AMPLIFIER GAIN/MUTE VERB	145
GET PARAMETER VERB	146
GET CONNECTION LIST ENTRY VERB	146
PGA CONTROL VERB (VENDOR-SPECIFIC)	147
PGA2 SELECTOR WIDGET (NID = 0BH)	149
AMPLIFIER GAIN/MUTE VERB	149
GET PARAMETER VERB	150
GET CONNECTION LIST ENTRY VERB	150
PGA CONTROL VERB (VENDOR-SPECIFIC)	151
PORT-E PIN COMPLEX WIDGET (NID = 0CH)	153
GET PARAMETER VERB	153
PIN WIDGET CONTROL VERB	154
UNSOLICITED RESPONSE VERB	154
PIN SENSE VERB	154
EAPD/BTL VERB	154
CONFIGURATION DEFAULT VERB	155
UNSOLICITED RESPONSE PRIORITY CONTROL VERB (VENDOR-SPECIFIC)	157
AUTO-MUTE CONTROL VERB (VENDOR-SPECIFIC)	157
PORT-B PIN COMPLEX WIDGET (NID = 0DH)	159
AMPLIFIER GAIN/MUTE VERB	159
GET PARAMETER VERB	160
PIN WIDGET CONTROL VERB	161
UNSOLICITED RESPONSE VERB	161
PIN SENSE VERB	161
EAPD/BTL VERB	162
CONFIGURATION DEFAULT VERB	162
UNSOLICITED RESPONSE PRIORITY CONTROL VERB (VENDOR-SPECIFIC)	164
DIFFERENTIAL VERB (VENDOR-SPECIFIC)	164
AUTO-MUTE CONTROL VERB (VENDOR-SPECIFIC)	165
PORT-D PIN COMPLEX WIDGET (NID = 0EH)	167
AMPLIFIER GAIN/MUTE VERB	167
GET PARAMETER VERB	168
PIN WIDGET CONTROL VERB	169
CONFIGURATION DEFAULT VERB	169
S/PDIF OUT PIN COMPLEX WIDGET (NID = 0FH)	173
GET PARAMETER VERB	173
GET CONNECTION LIST ENTRY VERB	174
PIN WIDGET CONTROL VERB	174

UNSOLICITED RESPONSE VERB	174
PIN SENSE VERB	175
CONFIGURATION DEFAULT VERB	175
INTERNAL PATH VERB (VENDOR-SPECIFIC)	177
UNSOLICITED RESPONSE PRIORITY CONTROL VERB (VENDOR-SPECIFIC)	177
S/PDIF IN PIN COMPLEX WIDGET (NID = 10H)	179
GET PARAMETER VERB	179
PIN WIDGET CONTROL VERB	180
UNSOLICITED RESPONSE VERB	180
PIN SENSE VERB	180
CONFIGURATION DEFAULT VERB	181
UNSOLICITED RESPONSE PRIORITY CONTROL VERB (VENDOR-SPECIFIC)	183
GET S/PDIF IN STATUS VERB (VENDOR-SPECIFIC)	183
S/PDIF IN CONTROL VERB (VENDOR-SPECIFIC)	184
PORT-A PIN COMPLEX WIDGET (NID = 11H)	185
GET PARAMETER VERB	185
GET CONNECTION LIST ENTRY VERB	186
PIN WIDGET CONTROL VERB	186
UNSOLICITED RESPONSE VERB	186
PIN SENSE VERB	187
CONFIGURATION DEFAULT VERB	187
UNSOLICITED RESPONSE PRIORITY CONTROL VERB (VENDOR-SPECIFIC)	189
PORT-G PIN COMPLEX WIDGET (NID = 12H)	191
GET PARAMETER VERB	191
GET CONNECTION LIST ENTRY VERB	192
PIN WIDGET CONTROL VERB	192
UNSOLICITED RESPONSE VERB	192
PIN SENSE VERB	192
CONFIGURATION DEFAULT VERB	193
UNSOLICITED RESPONSE PRIORITY CONTROL VERB (VENDOR-SPECIFIC)	195
PORT-F PIN COMPLEX WIDGET (NID = 13H)	197
GET PARAMETER VERB	197
GET CONNECTION LIST ENTRY VERB	198
PIN WIDGET CONTROL VERB	198
UNSOLICITED RESPONSE VERB	198
PIN SENSE VERB	198
CONFIGURATION DEFAULT VERB	199
UNSOLICITED RESPONSE PRIORITY CONTROL VERB (VENDOR-SPECIFIC)	201
BEEP GENERATOR WIDGET (NID = 14H)	203
AMPLIFIER GAIN/MUTE VERB	203
GET PARAMETER VERB	204
BEEP GENERATION VERB	204
BEEP MASK SELECTION VERB (VENDOR SPECIFIC)	205
MIC2 AUDIO INPUT CONVERTER WIDGET (NID = 15H)	207
STREAM FORMAT VERB	207
GET PARAMETER VERB	208
GET CONNECTION LIST ENTRY VERB	209
PROCESSING STATE VERB	209
CONVERTER STREAM, CHANNEL VERB	210
UNSOLICITED RESPONSE VERB	210
UNSOLICITED RESPONSE PRIORITY CONTROL VERB (VENDOR-SPECIFIC)	210
CHANNEL COPY VERB (VENDOR-SPECIFIC)	211
PORT-H PIN COMPLEX WIDGET (NID = 16H)	213
AMPLIFIER GAIN/MUTE VERB	213
GET PARAMETER VERB	214

GET CONNECTION LIST ENTRY VERB.....	215
PIN WIDGET CONTROL VERB.....	215
CONFIGURATION DEFAULT VERB.....	216
INTERNAL PATH VERB (VENDOR-SPECIFIC).....	218
S/PDIF TX 2 AUDIO OUTPUT CONVERTER WIDGET (NID = 17H).....	219
STREAM FORMAT VERB.....	219
GET PARAMETER VERB.....	220
CONVERTER STREAM, CHANNEL VERB.....	221
UNSOLICITED RESPONSE VERB.....	221
S/PDIF CONVERTER CONTROL VERB.....	222
INTERNAL PATH VERB (VENDOR-SPECIFIC).....	223
TX CHANNEL STATUS CONTROL VERB (VENDOR-SPECIFIC).....	223
CHANNEL STATUS DATA PACKING CONFIGURATION VERB (VENDOR-SPECIFIC).....	224
UNSOLICITED RESPONSE PRIORITY CONTROL VERB (VENDOR-SPECIFIC).....	224
APPLICATIONS INFORMATION.....	225
RECOMMENDED EXTERNAL COMPONENTS.....	225
REQUIRED JACK DETECT COMPONENTS.....	226
PACKAGE DIMENSIONS.....	227
IMPORTANT NOTICE.....	228
REVISION HISTORY.....	229

PIN CONFIGURATION

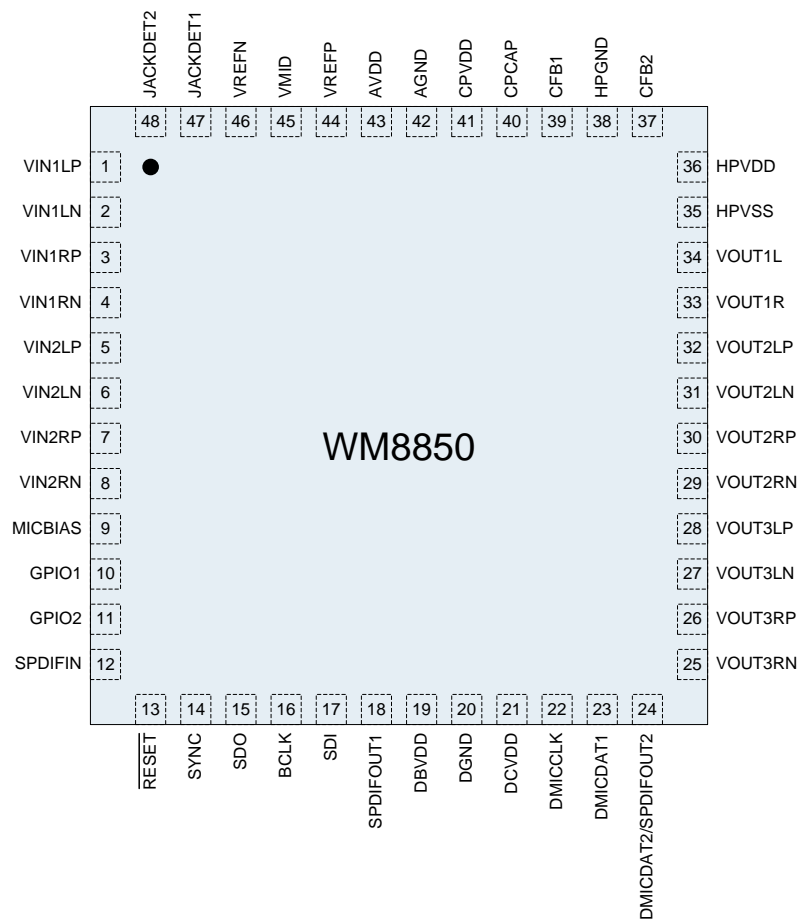

ORDERING INFORMATION

ORDER CODE	TEMPERATURE RANGE	PACKAGE	MOISTURE SENSITIVITY LEVEL	PEAK SOLDERING TEMPERATURE
WM8850GEFL/V	-40°C to +85°C	48-pin QFN (Pb-free)	MSL3	260°C
WM8850GEFL/RV	-40°C to +85°C	48-pin QFN (Pb-free, tape and reel)	MSL3	260°C

Note:

Reel quantity = 2200

PIN DESCRIPTION

PIN NO	NAME	TYPE	DESCRIPTION
1	VIN1LP	Analogue input	Left channel 1 positive input
2	VIN1LN	Analogue input	Left channel 1 negative input
3	VIN1RP	Analogue input	Right channel 1 positive input
4	VIN1RN	Analogue input	Right channel 1 negative input
5	VIN2LP	Analogue input	Left channel 2 positive input
6	VIN2LN	Analogue input	Left channel 2 negative input
7	VIN2RP	Analogue input	Right channel 2 positive input
8	VIN2RN	Analogue input	Right channel 2 negative input
9	MICBIAS	Analogue output	Microphone bias output
10	GPIO1	Digital input / output	General purpose digital input/output 1
11	GPIO2	Digital input / output	General purpose digital input/output 2
12	SPDIFIN	Digital input	S/PDIF Input
13	/RESET	Digital input	Global reset (active low)
14	SYNC	Digital input	HDA frame sync, 48kHz
15	SDO	Digital input	Serial data output from HDA controller
16	BCLK	Digital input	HDA Link bit clock, 24MHz
17	SDI	Digital input / output	Serial data input to HDA controller
18	SPDIFOUT1	Digital output	S/PDIF output 1
19	DBVDD	Supply input	Digital buffer supply input
20	DGND	Supply input	Digital ground (return for DBVDD and DCVDD)
21	DCVDD	Supply input	Digital core supply input
22	DMICCLK	Digital output	Digital microphone clock output
23	DMICDAT1	Digital input	Digital microphone data input 1
24	DMICDAT2/ SPDIFOUT2	Digital input / output	Digital microphone data input 2 / S/PDIF output 2
25	VOUT3RN	Analogue output	Right channel 3 negative output
26	VOUT3RP	Analogue output	Right channel 3 positive output
27	VOUT3LN	Analogue output	Left channel 3 negative output
28	VOUT3LP	Analogue output	Left channel 3 positive output
29	VOUT2RN	Analogue output	Right channel 2 negative output
30	VOUT2RP	Analogue output	Right channel 2 positive output
31	VOUT2LN	Analogue output	Left channel 2 negative output
32	VOUT2LP	Analogue output	Left channel 2 positive output
33	VOUT1R	Analogue output	Right channel 1 output
34	VOUT1L	Analogue output	Left channel 1 output
35	HPVSS	Supply output	Charge pump negative supply decoupling point
36	HPVDD	Supply output	Charge pump positive supply decoupling point
37	CFB2	Analogue output	Charge pump flyback capacitor pin 2
38	HPGND	Supply input	Charge pump ground (return path for HPVDD and HPVSS)
39	CFB1	Analogue output	Charge pump flyback capacitor pin 1
40	CPCAP	Supply output	Internally generated regulated charge pump supply decoupling point
41	CPVDD	Supply input	Charge pump supply input
42	AGND	Supply input	Analogue ground (return path for AVDD and CPVDD)
43	AVDD	Supply input	Analogue supply input
44	VREFP	Analogue output	Analogue positive reference decoupling point
45	VMID	Analogue output	Midrail voltage decoupling point
46	VREFN	Analogue output	Analogue negative reference decoupling point
47	JACKDET1	Analogue output	Jack detect sense 1
48	JACKDET2	Analogue output	Jack detect sense 2

ABSOLUTE MAXIMUM RATINGS

Absolute Maximum Ratings are stress ratings only. Permanent damage to the device may be caused by continuously operating at or beyond these limits. Device functional operating limits and guaranteed performance specifications are given under Electrical Characteristics at the test conditions specified.



ESD Sensitive Device. This device is manufactured on a CMOS process. It is therefore generically susceptible to damage from excessive static voltages. Proper ESD precautions must be taken during handling and storage of this device.

Cirrus Logic tests its package types according to IPC/JEDEC J-STD-020B for Moisture Sensitivity to determine acceptable storage conditions prior to surface mount assembly. These levels are:

MSL1 = unlimited floor life at <30°C / 85% Relative Humidity. Not normally stored in moisture barrier bag.

MSL2 = out of bag storage for 1 year at <30°C / 60% Relative Humidity. Supplied in moisture barrier bag.

MSL3 = out of bag storage for 168 hours at <30°C / 60% Relative Humidity. Supplied in moisture barrier bag.

The Moisture Sensitivity Level for each package type is specified in Ordering Information.

CONDITION	MIN	MAX
Analogue supply voltage (AVDD)	-0.3V	+7V
Charge pump supply voltage (CPVDD)	-0.3V	+7V
Digital core supply voltage (DCVDD)	-0.3V	+2.5V
Digital buffer supply voltage (DBVDD)	-0.3V	+7V
Voltage range digital inputs	DGND -0.3V	DBVDD +0.3V
Voltage range analogue inputs	AGND -0.3V	AVDD +0.3V
Operating temperature range, T _A	-40°C	+85°C
Junction temperature, T _{JMAX}	-40°C	+150°C
Storage temperature after soldering	-65°C	+150°C

RECOMMENDED OPERATING CONDITIONS

PARAMETER	SYMBOL	MIN	TYP	MAX	UNIT
CODEC Power Supplies					
Digital core supply range	DCVDD	1.62	1.8	1.98	V
Digital buffer supply range	DBVDD	2.97	3.3	3.63	V
Analogue supply range	AVDD	4.5	5.0	5.25	V
Charge pump supply range	CPVDD	4.5	5.0	5.25	V
Ground	DGND, AGND, HPGND		0		V

Notes:

- Analogue and digital grounds must always be within 0.3V of each other.
- All digital and analogue supplies are completely independent from each other (i.e. not internally connected).

THERMAL PERFORMANCE

Thermal analysis should be performed in the intended application to prevent the WM8850 from exceeding maximum junction temperature. Several contributing factors affect thermal performance most notably the physical properties of the mechanical enclosure, location of the device on the PCB in relation to surrounding components and the number of PCB layers. Connecting the GND paddle through thermal vias and into a large ground plane will aid heat extraction.

Three main heat transfer paths exist to surrounding air as illustrated below in Figure 1:

- Package top to air (radiation).
- Package bottom to PCB (radiation).
- Package leads & paddle to PCB (conduction).

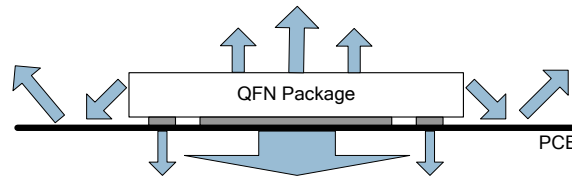

Figure 1 Heat Transfer Paths

The temperature rise T_R is given by $T_R = P_D * \Theta_{JA}$

- P_D is the power dissipated in the device.
- Θ_{JA} is the thermal resistance from the junction of the die to the ambient temperature and is therefore a measure of heat transfer from the die to surrounding air. Θ_{JA} is determined with reference to JEDEC standard JESD51-9.

The junction temperature T_J is given by $T_J = T_A + T_R$, where T_A is the ambient temperature.

PARAMETER	SYMBOL	MIN	TYP	MAX	UNIT
Operating temperature range	T_A	-40		85	°C
Operating junction temperature	T_J	-40		125	°C
Thermal Resistance	Θ_{JA}		29		°C/W

ELECTRICAL CHARACTERISTICS

Test Conditions

AVDD = CPVDD = 5V, DBVDD = 3.3V, DCVDD = 1.8V, T_A = +25°C, 1kHz signal, f_s = 48kHz, 24-bit data unless otherwise stated.

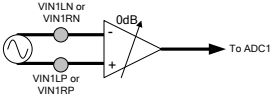
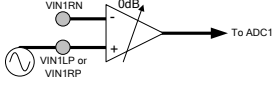
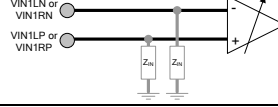
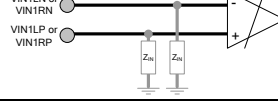
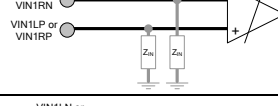
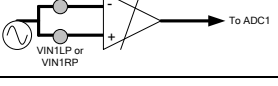
PARAMETER	SYMBOL	TEST CONDITIONS	MIN	TYP	MAX	UNIT
Analogue Input 1 (VIN1LP, VIN1LN, VIN1RP, VIN1RN)						
Maximum Differential Input Signal Level	V _{INDIFF(max)}	0dB gain 		2.25 x AVDD/5		V _{RMS}
Maximum Single-ended Input Signal Level	V _{INSE(max)}	0dB gain 		1.6 x AVDD/5		V _{RMS}
Input impedance	Z _{IN}	-12dB gain 		42		kΩ
		0dB gain 		27		kΩ
		+12dB gain 		9		kΩ
Common Mode Rejection Ratio	CMRR	20Hz to 20kHz 		55		dB
Minimum PGA Gain Setting				-12		dB
Maximum PGA Gain Setting				+12		dB
PGA Gain Step Size		Guaranteed monotonic		0.5		dB

Test Conditions

AVDD = CPVDD = 5V, DBVDD = 3.3V, DCVDD = 1.8V, $T_A = +25^\circ\text{C}$, 1kHz signal, $f_s = 48\text{kHz}$, 24-bit data unless otherwise stated.

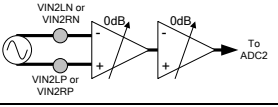
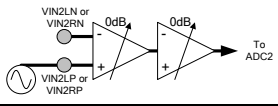
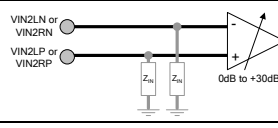
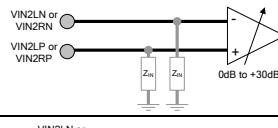
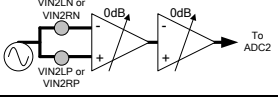
PARAMETER	SYMBOL	TEST CONDITIONS	MIN	TYP	MAX	UNIT
Analogue Input 2 (VIN2LP, VIN2LN, VIN2RP, VIN2RN)						
Maximum Differential Input Signal Level	$V_{\text{INDIFF(max)}}$	0dB gain 		$2.25 \times \text{AVDD}/5$		V_{RMS}
Maximum Single-ended Input Signal Level	$V_{\text{INSE(max)}}$	0dB gain 		$1.1 \times \text{AVDD}/5$		V_{RMS}
Input impedance	Z_{IN}	Single-ended or Differential (Inverting) 		10		k Ω
		Differential (Non-inverting) 		120		k Ω
Common Mode Rejection Ratio	CMRR	20Hz to 20kHz 		65		dB
Microphone Preamp Gain Options				0 10 20 30		dB
Minimum PGA Gain Setting				-12		dB
Maximum PGA Gain Setting				+12		dB
PGA Gain Step Size		Guaranteed monotonic		0.5		dB

Test Conditions

 AVDD = CPVDD = 5V, DBVDD = 3.3V, DCVDD = 1.8V, T_A = +25°C, 1kHz signal, f_s = 48kHz, 24-bit data unless otherwise stated.

PARAMETER	SYMBOL	TEST CONDITIONS	MIN	TYP	MAX	UNIT
ADC1 Performance						
Signal to Noise Ratio	SNR	Unweighted		102		dB
		A-weighted	100	105		dB
		A-weighted f _s =96kHz		105		dB
Dynamic Range	DNR	A-weighted -60dBFS		105		dB
Total Harmonic Distortion	THD	-1dBFS		-95	-90	dB
		-1dBFS f _s =96kHz		-95		dB
Channel Separation		1kHz		86		dB
		20Hz to 20kHz		86		dB
Channel Level Matching		0dBFS		0.1		dB
Channel Phase Deviation				0.01		°
Power Supply Rejection Ratio	PSRR	1kHz, 100mVpp on AVDD		90		dB
		20Hz to 20kHz, 100mVpp on AVDD		70		dB

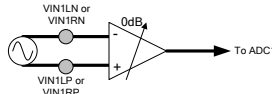

Test Conditions

AVDD = CPVDD = 5V, DBVDD = 3.3V, DCVDD = 1.8V, T_A = +25°C, 1kHz signal, fs = 48kHz, 24-bit data unless otherwise stated.

PARAMETER	SYMBOL	TEST CONDITIONS	MIN	TYP	MAX	UNIT
ADC2 Performance						
Signal to Noise Ratio	SNR	Unweighted		100		dB
		A-weighted		95	103	dB
		A-weighted fs=96kHz			103	
Dynamic Range	DNR	A-weighted -60dBFS		103		dB
Total Harmonic Distortion	THD	-1dBFS		-95	-90	dB
Channel Separation		1kHz		87		dB
		20Hz to 20kHz		84		dB
Channel Level Matching		0dBFS		0.1		dB
Channel Phase Deviation				0.01		°
Power Supply Rejection Ratio	PSRR	1kHz, 100mVpp on AVDD		90		dB
		20Hz to 20kHz, 100mVpp on AVDD		70		dB

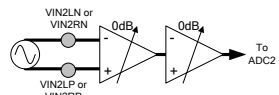

Test Conditions

AVDD = CPVDD = 5V, DBVDD = 3.3V, DCVDD = 1.8V, T_A = +25°C, 1kHz signal, fs = 48kHz, 24-bit data unless otherwise stated.

PARAMETER	SYMBOL	TEST CONDITIONS	MIN	TYP	MAX	UNIT
Microphone Bias Generator						
Output Voltage		V _{RefEn[2:0]} = 001		0.5x AVDD		V
		V _{RefEn[2:0]} = 100		0.8x AVDD		V
Current Source Capability					2.5	mA
Power Supply Rejection Ratio	PSRR	1kHz, 100mVpp on AVDD		100		dB
		20Hz to 20kHz, 100mVpp on AVDD		88		dB

Test Conditions

 AVDD = CPVDD = 5V, DBVDD = 3.3V, DCVDD = 1.8V, T_A = +25°C, 1kHz signal, fs = 48kHz, 24-bit data unless otherwise stated.

PARAMETER	SYMBOL	TEST CONDITIONS	MIN	TYP	MAX	UNIT
Digital Microphone Interface						
Digital Microphone Clock Frequencies				1.024 1.4112 2.048 2.8224 3.072		MHz
Signal to Noise Ratio	SNR			96		dB
Minimum Digital Gain Setting				-12		dB
Maximum Digital Gain Setting				+32		dB
Digital Gain Step Size				0.5		dB

Test Conditions

 AVDD = CPVDD = 5V, DBVDD = 3.3V, DCVDD = 1.8V, T_A = +25°C, 1kHz signal, fs = 48kHz, 24-bit data unless otherwise stated.

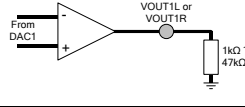
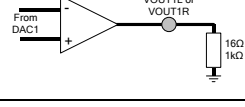
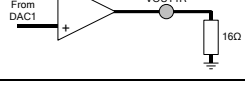
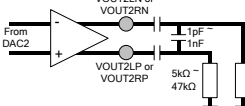
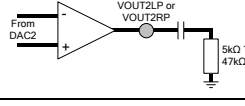
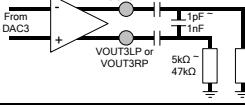
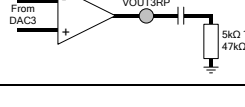
PARAMETER	SYMBOL	TEST CONDITIONS	MIN	TYP	MAX	UNIT
Analogue Output 1 (VOUT1L, VOUT1R)						
Full Scale Output Signal Level	V _{OUT}	R _L = 1kΩ to 47kΩ H-Phn Enable = 0			2 x AVDD/5	V _{RMS}
		R _L = 16Ω to 1kΩ H-Phn Enable = 1			0.8 x AVDD/5	V _{RMS}
Maximum Rated Output Power	P _{OUT(max)}	R _L = 16Ω			40	mW
Load Impedance	R _L		16		47k	Ω
Load Capacitance	C _L				1	nF
DC Offset		Measured between VOUT1L/R and AGND with path fully enabled but no signal playing	-1	0	+1	mV
Analogue Output 2 (VOUT2L, VOUT2LN, VOUT2RP, VOUT2RN)						
Differential Full Scale Output Signal Level	V _{OUT}	R _L = 5kΩ to 47kΩ			2 x AVDD/5	V _{RMS}
Single-ended Full Scale Output Signal Level	V _{OUT}	R _L = 5kΩ to 47kΩ			1 x AVDD/5	V _{RMS}
Load Impedance	R _L		5		47	kΩ
Load Capacitance	C _L				1	nF
Analogue Output 3 (VOUT3L, VOUT3LN, VOUT3RP, VOUT3RN)						
Differential Full Scale Output Signal Level	V _{OUT}	R _L = 5kΩ to 47kΩ			2 x AVDD/5	V _{RMS}
Single-ended Full Scale Output Signal Level	V _{OUT}	R _L = 5kΩ to 47kΩ			1 x AVDD/5	V _{RMS}
Load Impedance	R _L		5		47	kΩ
Load Capacitance	C _L				1	nF

Test Conditions

 AVDD = CPVDD = 5V, DBVDD = 3.3V, DCVDD = 1.8V, T_A = +25°C, 1kHz signal, f_s = 48kHz, 24-bit data unless otherwise stated.

PARAMETER	SYMBOL	TEST CONDITIONS	MIN	TYP	MAX	UNIT
DAC1 Path Performance (VOUT1L and VOUT1R into 10kΩ Line Load)						
Signal to Noise Ratio	SNR	Unweighted		105		dB
		A-weighted	100	108		dB
		A-weighted f _s =96kHz		108		dB
Out of Band Signal to Noise Ratio (0.6f _s to 150kHz)	OBSNR	F _s > 11.025kHz		80		dB
		F _s ≤ 11.025kHz		75		dB
Dynamic Range	DNR	A-weighted -60dBFS		108		dB
Total Harmonic Distortion	THD	0dBFS		-96	-85	dB
		0dBFS f _s =96kHz		-96	-85	dB
Channel Separation		1kHz		115		dB
		20Hz to 20kHz		110		dB
Channel Level Matching		0dBFS		0.1		dB
Channel Phase Deviation				0.01		°
AVDD Power Supply Rejection Ratio	AVDD PSRR	1kHz, 100mVpp on AVDD		51		dB
		20Hz to 20kHz, 100mVpp on AVDD		50		dB
CPVDD Power Supply Rejection Ratio	CPVDD PSRR	1kHz, 100mVpp on CPVDD		86		dB
		20Hz to 20kHz, 100mVpp on CPVDD		75		dB

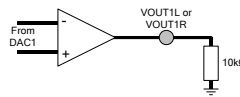

Test Conditions

AVDD = CPVDD = 5V, DBVDD = 3.3V, DCVDD = 1.8V, T_A = +25°C, 1kHz signal, f_s = 48kHz, 24-bit data unless otherwise stated.

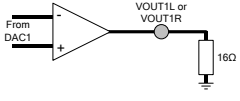
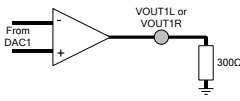
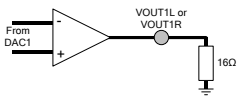
PARAMETER	SYMBOL	TEST CONDITIONS	MIN	TYP	MAX	UNIT
DAC1 Path Performance (VOUT1L and VOUT1R into 16Ω Headphone Load)						
Total Harmonic Distortion	THD	$P_{OUT} = 30mW$ $R_L = 16\Omega$ 		--80	-73	dB
				0.01		%
		$P_{OUT} = 10mW$ $R_L = 300\Omega$ 		-80		dB
				0.01		%
Idle Channel Noise		$R_L = 16\Omega$ A-weighted 	90	98		dBV
				12.26		μV_{rms}
Channel Separation		$R_L = 16\Omega$ 1kHz		85		dB
		$R_L = 16\Omega$ 20Hz to 20kHz		72		dB

Test Conditions

AVDD = CPVDD = 5V, DBVDD = 3.3V, DCVDD = 1.8V, T_A = +25°C, 1kHz signal, f_s = 48kHz, 24-bit data unless otherwise stated.

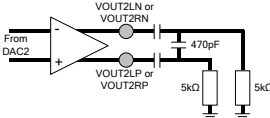
PARAMETER	SYMBOL	TEST CONDITIONS	MIN	TYP	MAX	UNIT
DAC2 Path Performance (VOUT2LP, VOUT2LN, VOUT2RP and VOUT2N into 10kΩ Line Load)						
DAC3 Path Performance (VOUT3LP, VOUT3LN, VOUT3RP and VOUT3N into 10kΩ Line Load)						
Signal to Noise Ratio	SNR	Unweighted		103		dB
		A-weighted		100	106	dB
		A-weighted f _s =96kHz			106	
Out of Band Signal to Noise Ratio (0.6f _s to 150kHz)	OBSNR	F _s > 11.025kHz		80		dB
		F _s ≤ 11.025kHz		75		dB
Dynamic Range	DNR	A-weighted -60dBFS		106		dB
Total Harmonic Distortion	THD	0dBFS		-92		dB
		0dBFS f _s =96kHz		-92		dB
Channel Separation		20Hz to 20kHz		102		dB
Channel Level Matching		0dBFS		0.1		dB
Channel Phase Deviation				0.01		°
AVDD Power Supply Rejection Ratio	AVDD PSRR	1kHz, 100mVpp on AVDD		75		dB
		20Hz to 20kHz, 100mVpp on AVDD	55			dB

Test Conditions

 AVDD = CPVDD = 5V, DBVDD = 3.3V, DCVDD = 1.8V, T_A = +25°C, 1kHz signal, fs = 48kHz, 24-bit data unless otherwise stated.

PARAMETER	SYMBOL	TEST CONDITIONS	MIN	TYP	MAX	UNIT
S/PDIF Receiver Specification						
Input Signal Level		IEC-60958 Compatible Input Mode	200	500		mV _{p-p}
Input Signal Logic High	V _{IH(S/PDIF)}	Normal CMOS Compatible Input Mode	0.7 *			V
		Low-Amplitude CMOS Compatible Input Mode	0.4 *		1.8	V
Input Signal Logic Low	V _{IL(S/PDIF)}	Normal CMOS Compatible Input Mode			0.3 *	V
		Low-Amplitude CMOS Compatible Input Mode			DBVDD x 0.2	V
Input Pin Bias Voltage		IEC-60958 Compatible Input Mode		0.5 *		V
Input Impedance	Z _{IN}	IEC-60958 Compatible Input Mode	7.5			kΩ
		Normal CMOS Compatible Input Mode	100			kΩ
Input Hysteresis		IEC-60958 Compatible Input Mode		50		mV
		Normal CMOS Compatible Input Mode		300		mV
		Low-Amplitude CMOS Compatible Input Mode		150		mV
Input Sample Rate Lock Tolerance		Includes maximum reference clock error of ±0.025% as allowed by HDA Specification			10000	ppm
			-1		+1	%
Lock Delay				3		192 Frame Blocks
S/PDIF Stream Jitter Tolerance		UI = 1/fs _(in)			10	UI
Input Sample Rate Support				32 44.1 48 88.2 96		kHz

Test Conditions

 AVDD = CPVDD = 5V, DBVDD = 3.3V, DCVDD = 1.8V, T_A = +25°C, 1kHz signal, fs = 48kHz, 24-bit data unless otherwise stated.

PARAMETER	SYMBOL	TEST CONDITIONS	MIN	TYP	MAX	UNIT
S/PDIF Transmitter Specification						
Output Signal Logic High	V _{OH(S/PDIF)}		0.9 * DBVDD			V
Output Signal Logic Low	V _{OL(S/PDIF)}				0.1 * DBVDD	V
Output Current Source/Sink Capability		DBVDD = 1.8V	7			mA
		DBVDD = 3.63V	15			mA
Output Sample Rate Tolerance		Includes maximum reference clock error of ±0.025% as allowed by HDA Specification			1000	ppm
			-0.1		+0.1	%
Output Sample Rate Support				32 44.1 48 88.2 96 176.4 192		kHz

Test Conditions

 AVDD = CPVDD = 5V, DBVDD = 3.3V, DCVDD = 1.8V, T_A = +25°C, 1kHz signal, fs = 48kHz, 24-bit data unless otherwise stated.

PARAMETER	SYMBOL	TEST CONDITIONS	MIN	TYP	MAX	UNIT
Analogue References						
Positive Voltage Reference	VREFP			0.9 * AVDD		V
Negative Voltage Reference	VREFN			0.1 * AVDD		V
Midrail Voltage Reference	VMID			0.5 * AVDD		V
Charge Pump Cap Level	CPCAP			3.15		V
Midrail Voltage Resistance	R _{VMID}	AVDD to VMID or VMID to AGND VMID_SEL[1:0]=00		12.5		kΩ
		AVDD to VMID or VMID to AGND VMID_SEL[1:0]=01		75		kΩ
		AVDD to VMID or VMID to AGND VMID_SEL[1:0]=10		37.5		kΩ
		AVDD to VMID or VMID to AGND VMID_SEL[1:0]=11		375		kΩ
Digital Input / Output						
Input High Level	V _{IH}		0.65 * DBVDD			V
Input Low Level	V _{IL}				0.35 * DBVDD	V
Output High Level	V _{OH}		0.9 * DBVDD			V
Output Low Level	V _{OL}				0.1 * DBVDD	V
Input Capacitance					7.5	pF
Input Leakage			-0.1		+0.1	μA

TERMINOLOGY

1. Signal-to-Noise Ratio (dB) – SNR is a measure of the difference in level between the full scale output signal and the output with no input signal applied.
2. Total Harmonic Distortion (dB) – THD is the level of the rms value of the sum of harmonic distortion products relative to the amplitude of the applied input signal.
3. Total Harmonic Distortion plus Noise (dB) – THD+N is the level of the rms value of the sum of harmonic distortion products plus noise in the specified bandwidth relative to the amplitude of the applied input signal.
4. Crosstalk (L/R) (dB) – left-to-right and right-to-left channel crosstalk is the measured signal level in the idle channel at the test signal frequency relative to the signal level at the output of the active channel. The active channel is configured and supplied with an appropriate input signal to drive a full scale output, with signal measured at the output of the associated idle channel. For example, measured signal level on the output of the idle right channel with a full scale signal level at the output of the active left channel.
5. Multi-Path Channel Separation (dB) – is the measured signal level in the idle path at the test signal frequency relative to the signal level at the output of the active path. The active path is configured and supplied with an appropriate input signal to drive a full scale output, with signal measured at the output of the specified idle path.
6. All performance measurements carried out with 20kHz low pass filter, and where noted an A-weighted filter. Failure to use such a filter will result in higher THD and lower SNR readings than are found in the Electrical Characteristics. The low pass filter removes out of band noise; although it is not audible it may affect dynamic specification values.
7. Mute Attenuation – This is a measure of the difference in level between the full scale output signal and the output with mute applied.
8. Channel Level Matching (dB) – the difference in output level between channels in a stereo pair.
9. Channel Phase Deviation (Degrees) – the difference in phase between channels in a stereo pair.
10. Idle Channel Noise (dBV) – absolute rms measurement of the noise floor over the 20Hz to 20kHz band.

POWER CONSUMPTION

Test Conditions

AVDD = CPVDD = 5V, DCVDD = DBVDD = 1.8V, T_A = +25°C, fs = 48kHz, 24-bit data unless otherwise stated.

PARAMETER	TEST CONDITIONS	AVDD (mA)	CPVDD (mA)	DBVDD (mA)	DCVDD (mA)
Render paths					
Headphone playback only	DAC1 & AFG D0, stream enabled R _L =47kΩ, quiescent	26.1	8.1	<0.1	9.1
Headphone playback & one line output	DAC1, DAC2 & AFG D0, stream enabled R _L =47kΩ, quiescent	36.7	8.1	<0.1	10.2
Stereo line output only	DAC2 or DAC3 & AFG D0, stream enabled R _L =47kΩ, quiescent	23.3	0.0	<0.1	9.0
All analogue outputs	DAC1, DAC2, DAC3 & AFG D0, stream enabled R _L =47kΩ, quiescent	47.0	8.0	<0.1	11.4
Capture paths					
Line record only	ADC1 & AFG D0, stream enabled quiescent	46.2	0.0	0.1	9.3
Analogue microphone record only	ADC1 & AFG D0, stream enabled quiescent	53.8	0.0	0.1	9.3
Combination paths					
Headphone playback & microphone record	ADC1, DAC1 & AFG D0, stream enabled quiescent	62.9	8.1	0.1	13.0
All blocks enabled	All blocks D0	106.6	8.1	0.1	15.8
All blocks disabled	All blocks D3 ^(Note 1) , BCLK stopped	12.3	0.0	<0.1	2.4
All blocks disabled, lowest power mode	Vendor-specific D4 ^(Note 2) , BCLK stopped	0.0	0.0	0.0	2.4

Notes:

1. D3 state allows for jack detect events to issue wake command to enable the system to wake-up
2. D4 state powers down all analogue circuit blocks. CODEC can no longer generate wakes, but can be woken up using the HD Link and initialised normally without the need for a power cycle.

SIGNAL TIMING REQUIREMENTS

Signal timing requirements are as defined in the High Definition Audio Specification Revision 1.0, section 6.2.3.1. This section of the specification is repeated here for completeness.

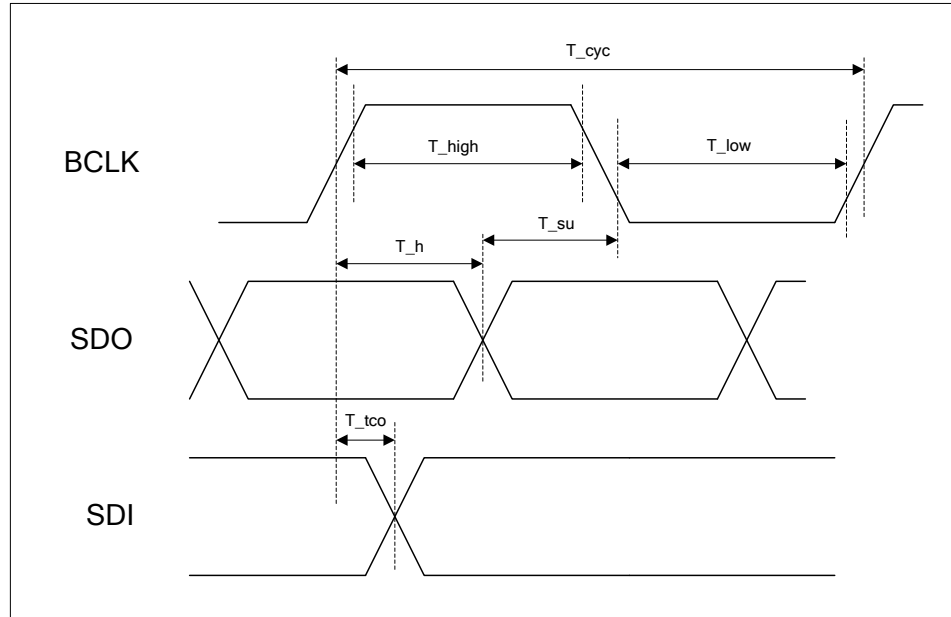

Test Conditions

DBVDD=3.3V, AVDD=CPVDD=5V, DCVDD=1.8V, T_A=+25°C

PARAMETER	SYMBOL	MIN	TYP	MAX	UNIT
Period of BCLK including jitter	T _{cyc}	41.163	41.67	42.171	ns
High phase of BCLK	T _{high}	17.5			ns
Low phase of BCLK	T _{low}	17.5			ns
BCLK jitter			150	500	ps
Time after rising edge of BCLK that SDI becomes valid	T _{tco}	3		11	ns
Setup for SDO at both rising and falling edge of BCLK	T _{su}	5			ns
Hold for SDO at both rising and falling edge of BCLK	T _h	5			ns

Table 1 High Definition Audio Link I/O Signal Timing

Notes:

1. Measurement points are as defined in the High Definition Audio Specification Revision 1.0 at either 0.35*DBVDD, 0.5*DBVDD or 0.65*DBVDD as appropriate
2. Period specification for BCLK is the long term average frequency measured over 1ms. BCLK has a 100ppm tolerance in the High Definition Audio Architecture
3. 42/58% is the worst case BCLK duty cycle at the WM8850
4. The WM8850 meets the timing requirements with the slew rate of the inputs in the range of 1V/ns to 3V/ns

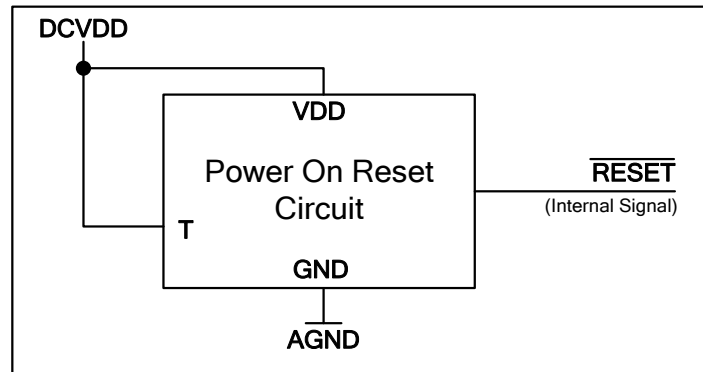
INTERNAL POWER ON RESET CIRCUIT

Figure 2 Internal Power on Reset Circuit Schematic

The WM8850 includes an internal Power-On-Reset Circuit, as shown in Figure 2, which is used to reset the digital logic into a default state after power up. The POR circuit is both powered from and monitors DCVDD. It asserts the internal RESET low if DCVDD is below a minimum threshold.

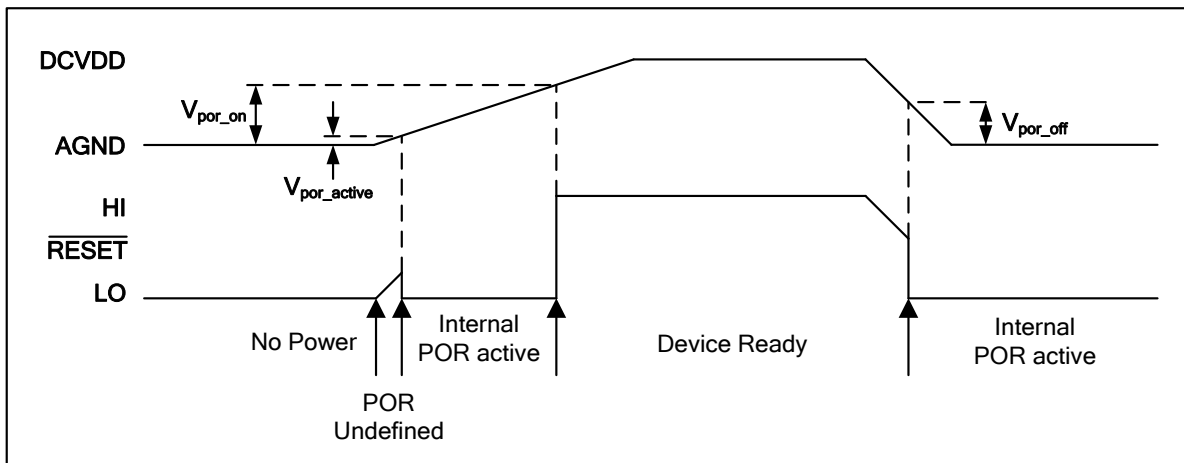

Figure 3 Typical Power up Sequence

Figure 3 shows a typical power-up sequence. The RESET signal is undefined until DCVDD has exceeded the minimum threshold, V_{por_active} . Once this threshold has been exceeded, RESET is asserted low and the chip is held in reset. In this condition, all stimulus to the WM8850 is ignored. Once DCVDD has reached V_{por_on} , RESET is released high, all registers are in their default state and access to the WM8850 via the HDA Interface may take place.

On power down, RESET is asserted low whenever DCVDD drops below the minimum threshold V_{por_off} .

Typical Power-On Reset parameters for the WM8850 are defined in Table 2.

SYMBOL	MIN	TYP	MAX	UNIT
V_{por_active}		0.1		V
V_{por_on}		1.23		V
V_{por_off}		1.16		V

Table 2 Typical Power-On Reset parameters

INTRODUCTION

The WM8850 is a high performance multi-channel audio CODEC designed for high performance PC audio systems. The device offers full compatibility with the Intel High Definition Audio (HDA) specification revision 1.0, allowing seamless integration with industry-standard HDA controllers.

The WM8850 has three high performance stereo DACs to enable six channels of high definition audio, ideal for 5.1 channel applications. A high-performance ground-referenced stereo headphone amplifier utilises advanced charge pump and DC servo technology to minimise system cost and space without compromise on audio quality. Two stereo pairs of line outputs are also provided. These line outputs may be used at the output of the PC to enable connection to a 5.1 speaker system, or may be used connected to external speaker drivers in a notebook or netbook application.

The WM8850 also has two high performance stereo ADCs to provide Hi-Fi quality analogue line-in and microphone input digitisation. A low noise microphone bias with programmable output voltage is provided, ideally suited as a bias current source for ECM microphones. Additionally, the CODEC contains a digital microphone interface capable of supporting up to four independent digital microphones, allowing high quality microphone array implementations to be realised. One differential stereo input is provided for line level signals, while one pseudo-differential stereo input with integrated microphone preamplifier is provided.

The WM8850 also contains a S/PDIF transceiver which is fully compatible with IEC-60958-3. The S/PDIF receive and transmit paths each contain a sample rate converter (SRC) to enable asynchronous sample rate conversion between the S/PDIF receive/transmit and HDA interface clock domains. An additional S/PDIF transmitter is provided to allow direct output of a stereo stream from the HDA interface.

The WM8850 includes an integrated beep generator allowing system beeps to be played back through the output paths.

This datasheet assumes familiarity with the High Definition Audio Specification Revision 1.0, available from <http://www.intel.com/standards/hdaudio/>. For those verbs implemented in the WM8850 which are as defined in the High Definition Audio Specification Revision 1.0 there is no detailed text describing their use in this datasheet. However, detailed text describing the function of of vendor-specific verbs is provided. Additionally, a full list of each node and each verb implemented in the WM8850 is provided at the rear of the document.

CIRRUS LOGIC INTERPRETATION OF HDA SPECIFICATION

DOLBY AC3 (IEC-61937)

The AFG node and Converter Widget nodes have a parameter called *AC3* within the *Supported Stream Formats Parameter*. The Intel High Definition Audio specification states that *AC3* should be set to 1 if the node supports Dolby AC3 (IEC-61937) encoded data.

There is some ambiguity as to what is meant by "supports Dolby AC3 (IEC-61937)". The WM8850 does not support processing of Dolby AC3 (IEC-61937) encoded data but it does support the passing of AC3 data through the S/PDIF Converter Widgets.

Cirrus Logic interprets the Intel specification to mean that the *AC3* parameter should be set if a node supports the encoding/decoding of AC3 data, and so we set the WM8850 *AC3* parameters to 0.

When the S/PDIF Converters are passing AC3 (IEC-61937) data, the *Stream Format Verb* for the widget node should have *Bits* = 1 (for 16-bit formatting) and *Type* = 1 to indicate that non-PCM data is being passed. Note that setting *Type* is for controller purposes only, and the WM8850 performs the same operation regardless of what *Type* is set to.

The user should ensure that Sample Rate Converters (SRCs) are bypassed when S/PDIF contains AC3 data.

FLOAT32

The WM8850 performs a Fixed-point/Floating-point conversion. Fixed point format is <1,23>, while floating point format is IEEE-754, single precision 32-bit, full scale between -1.0 and 1.0 with silence at 0.0.

Floating point conversion is implemented in all Converter widgets. The conversion is enabled when the *Stream Format Verb* for the widget node has *Bits* set to 4 (for 32-bit formatting).

AUDIO WIDGETS CAPABILITIES PARAMETER: DIGITAL

The MIC1 audio path can begin at either Port-B (Analogue Microphone) or Port-D (Digital Microphone). This leads to some confusion when setting the *Widget Capability Parameter*. Bit [9] of this parameter is called *Digital* and is used to indicate if the widget acts on an analogue stream or on a digital stream.

In the cases of the MIC1 Converter (NID = 03h) and the MIC1 Mux (NID = 09h), these can act on both analogue or digital streams, depending on which microphone interface is being used. For these two nodes, *Digital* = 0 to indicate that the nodes act on analogue data, but the user should be aware that these nodes can also act on digital data when the digital microphone is being used.

The Port-D node has its *Digital* parameter set to 1 to indicate that it acts on digital data.

LATENCY

The group delay or latency for an audio path varies based on sample rate and processing steps (e.g. SRC). As variable reporting is not supported as part of the Intel HDA Specification, the *Delay* parameter in the *Audio Widgets Capabilities Parameter* is set to 0 to indicate that latency is not reported.

POWER STATES

Within the AFG, all power states are supported. These are interpreted as follows:

- D0: Fully on
- D1: Link active, Jack detection logic on, analogue references enabled, but converters and DSP logic still disabled.
- D2: Link active, Jack detection logic on, register read/write access possible but all modules in an audio path are disabled.
- D3: Link disabled (i.e. BCLK stopped), responses not possible but Jack detection logic on and capable of issuing a wake.
- D4: Power applied, and settings maintained. Jack detection logic off, and wake disabled.

The AFG node supports the *Power State* verb. Widget nodes also offer power control, but their settings are restricted to select only power states below that of the AFG power state setting. For example, if the AFG node is set at D1, widget nodes can be set to D1, D2, D3, but not D0.

The default power state of the AFG is D2 so as to allow the PLLs to lock during CODEC initialisation. The default power state of the widget nodes is D3 so as to minimise power consumption. Widget nodes do not support D4 as the D3 state is identical to D4 at the widget node level.

Power state transitions are done in sequence. For example, if a node is in power state D3, and the power state is set to D0, the transitions steps are D3-D2-D1-D0. If a *Get Power State* command is issued during the state transitions, the actual power state returned, will be the power state at the end of the frame that the *Power State* command was issued in.

It is possible that the actual power state returned is D3, D2 or D0 while the set power state returned is D0.

For low power operation, the link should be in the Link Reset state and the WM8850 AFG should be in D3 or D4. If the link is in the Link Reset state, and the WM8850 AFG was left in states D0, D1 or D2, the WM8850 cannot issue a power state changes request (i.e. wake).

The only settings that can be changed in the D4 state is the AFG Power State or AFG reset settings – any other changes will be ignored.

In D3, BCLK may be stopped after the WM8850 asserts the *PS-ClkStopOK* register in the AFG's *Power State* verb. The *PS-ClkStopOK* bit will remain asserted in power state D3 until the power state is modified to D0, D1 or D2. If the power state is changed to D4 while in power state D3 when the *PS-ClkStopOK* bit is set, software must poll the AFG *PS-Act* bits to determine when the WM8850 reports transition to power state D4 complete (and hence reports *PS-Act* as D4) before stopping the BCLK.

In D3, if the link is not in the Link Reset state and BCLK is running, the WM8850 will issue an unsolicited response rather than a wake.

In D3 (with the link in the Link Reset state), the WM8850 is capable of generating a wake (i.e. a power state change request). The Controller will respond to the wake by putting the WM8850 through an initialisation sequence. The initialisation sequence will not change the register settings, so the WM8850 will still report a power state of D3 but the WM8850 will be able to send responses, including any unsolicited response(s) that caused a wake to be issued.

As register settings are maintained in the D3/D4 states, the user should be aware that if the WM8850 is brought from D3/D4 to D0 and stream IDs had been previously assigned, data rendering and capture will commence. If this behaviour is not desired, the user should bring the WM8850 to state D3 and set the stream IDs to 0, or ensure that stream IDs are set to 0 prior to entering the D3/D4 state.

STREAM START/STOP

Sections 4.5.3 and 4.5.4 of the Intel HD Audio specification describe the starting and stopping of streams. While the descriptions are sufficient from a controller perspective, there are ambiguities from a CODEC perspective.

For each stream that goes through the HDA Link, there is a 'Stream Manager' module within the WM8850 whose function is to assemble/disassemble the stream packets within the link frame. The Stream Manager is disabled while the *Stream* value in the *Converter Stream, Channel Verb* is set to 0h. When disabled, the captured data will not be sent on the link, and data from the link will not be decoded for rendering.

For audio path configuration, it is assumed that the Stream ID is the last register to be set in the configuration sequence. When Stream ID is set to a non-zero value it has the effect of starting the stream. On starting the stream, Stream Managers associated with input converters begin transmitting data on the link, and Stream Managers associated with output converters begin to decode data with the corresponding stream tag.

Note: Audio paths with mute capabilities may have 'un-mute' as the final configuration step. For these paths, the stream will have started but the audio data will be zeroed until mute has been disabled.

There are test paths within the WM8850 that do not use the HDA Link. These paths can still be used when the Stream Manager is disabled.

The Stream Manager is also disabled when the associated converter widget is in power state D1, D2 or D3. Digital converters (i.e. S/PDIF) have a *DigEn* register bit. When this is set to 0, the associated stream manager is disabled.

It is assumed that the settings of the *Stream Format Verb* and *Converter Stream, Channel Verb* will not change when a stream is active (with the exception of changing the Stream ID to 0 to terminate the stream). Changing stream settings while a stream is active is an erroneous action, and may result in audio corruption.

SDI STREAM ORDER

The order of stream transmission on the SDI link is governed by the CODEC. The WM8850 will transmit streams with the lowest stream ID value first.

If a stream is started with a stream ID lower than an existing stream, then the new stream is transmitted earlier in the frame than the existing stream (i.e. the WM8850 auto-shuffles the stream placement within the frame). This moves the existing stream to further on in the frame than it was prior to the starting of the new stream. It is assumed that moving streams within a frame is acceptable to the Controller.

BANDWIDTH CONFLICTS

Sections 5.3.2.2 and 5.3.3.3 of the HD Audio spec describe the scenario of over-subscription of SDO and SDI bandwidths. It indicates that the final stream on the link is terminated prior to completion, and further behaviour is undefined.

SDO

It is possible that the SDO line could be oversubscribed, if all streams are active at their maximum sample rate, and word length. It is the responsibility of the Controller to handle this situation, and determine what is put on the SDO line during oversubscription. The WM8850 will produce unsolicited responses from the converter nodes that have not received the stream packets that they have been configured for.

SDI

The WM8850 invokes a protection mechanism, should a bandwidth over-subscription situation arise. The mechanism monitors the sample rate, and sample-size settings of a stream to detect oversubscription.

If the SDI line is over-subscribed, due to software configuration or configuration from the recovered S/PDIF sample-rate, the stream (or streams) assigned the highest Stream ID tag value, will be dropped, and an unsolicited response issued from the stream converter whose stream has been dropped.

A stream will be restarted on a re-issue of a non-zero stream ID. However, should the bandwidth problem still be present, the stream won't start and an unsolicited response will be re-sent.

Although there is a protection mechanism in the WM8850, it is the responsibility of the user to identify and rectify bandwidth problems.

SOFTWARE FORMATTED (RAW) S/PDIF

An S/PDIF sub-frame consists of a preamble, 24-bits of audio data, and four control bits. In Software Formatted (Raw) S/PDIF mode, all 24-bits of the audio data, plus the 4 bits of control information, plus a 4-bit encoding of the preamble (taking the last 4-bits of the 8-bit bi-phase encoded preamble) are transported across the link. Software Formatted S/PDIF mode is selected by setting the *Bits* register in the *Stream Format Verb* to 4h (i.e. 32-bits) and setting the *Type* register to 1.

SOURCE SYNCHRONOUS INPUT - S/PDIF RX

Extra Bandwidth

Section 5.4.3 of the HDA specification describes how source synchronous inputs should be handled.

Note: Source synchronous handling is only required when SRC1 is bypassed.

When the incoming sampling rate is slightly higher than the nominal stream sampling rate extra data transmission is required. The HDA specification states *"the CODEC may insert one or more additional complete sample blocks on the link, either within its normal allocated stream packet (making it larger than the nominal allocated size) or by creating a second stream packet within the frame."*

The WM8850 implements the first option, and will insert additional samples (in left/right pairs) within the stream packet. The Data Length field within the Stream tag will be updated to show that the stream packet contains additional samples.

If additional samples cannot be accommodated on SDI due to bandwidth problems, the additional samples are dropped, and an unsolicited response is issued from the S/PDIF Rx Converter Node with EF_STREAM_DROP set to 01h.

Loss of Lock

Should the S/PDIF Rx lose lock, an unsolicited response will be triggered to indicate the change in lock status. The data in the link sample blocks will be set to 0, and the stream will continue to run at the previously recovered sample rate. There may be several samples of data before the unsolicited response can be sent, but the data will be zeroed immediately.

If the S/PDIF Rx is in Software Formatted S/PDIF mode, and the loss of lock event occurs, all 32-bits of the data are zeroed.

Change in Sample Rate

Once a stream has started, stream parameters such as sample-size, number of channels, and sample rates should not be changed. For the S/PDIF Rx audio path, it is expected that any change of S/PDIF sample rate will cause the S/PDIF Rx to lose lock.

Once the S/PDIF Rx has gained lock to the new sample rate (or regained lock at the existing sample rate), the controller will be sent an unsolicited response.

The S/PDIF Rx audio path has two methods of handling the relock condition:

1. *Push Method*: where upon lock, the stream (assuming SRC1 is bypassed) immediately changes sample rate to the new recovered rate, and data is no longer overwritten with zeros.
2. *Controlled Method*: where zeroed data continues to be transmitted at the old sample rate, until the stream ID is set to 0. Upon re-assignment of the Stream ID, non-zeroed stream data is transmitted at the newly recovered sample rate.

These methods are selected using the *Unlock Ctrl* register in the SPDIF_IN Control Verb.

S/PDIF TX VALIDITY FLAG

The validity flag is bit [28] of an S/PDIF sub-frame. It is configured using *V-bit* in the *Digital Converter Control Verb*.

When the *V-bit* is set to 1, the validity flag for both sub-frames is set to 1.

When the *V-bit* is set to 0, the validity flag for both sub-frames is set to 0, unless an invalid sample is being transmitted for that sub-frame - in which case the validity flag is set to 1 for that sub-frame.

An invalid sample may occur under the following conditions:

- The Stream ID is set to 0
- SRC2 is enabled but is unlocked
- There has been a FIFO overrun/under-run condition in the S/PDIF Tx Stream Manager (i.e. a Stream Error).

Note: A Stream Error problem would only be present due to a problem upstream of the WM8850. A Stream Error triggers an unsolicited response with the *EF_STREAM_ERR* flag set. If an invalid sample is detected, it will be overwritten with all-zeros if *VCFG* in the *Digital Converter Control Verb* is set to 1.

CHANNEL NUMBERING

Multi-Channel Streams

Channels 0, 2, 4, etc will be assigned to the Left Channel of a stereo converter. Channels 1, 3, 5, etc will be assigned to the Right Channel of a stereo converter.

Channel synchronisation between channels is only guaranteed where stream packets are received by the WM8850 after all converters in a multi-channel stream have had their stream ID assigned.

Mono Streams

All converters are stereo. Where an input converter (ADC, S/PDIF Rx) is associated with a mono stream, only the left channel (channel 0) will be sent on the HDA Link.

In mono mode, right channel modules in the ADC will be disabled to save power.

Where an output converter (DAC, S/PDIF Tx) is associated with a mono stream, both left and right channels render the same samples. If both left and right DAC outputs are not desired, the unwanted channel can be muted.

A stream is assumed to be mono when its *Chan* control in the *Stream Format Verb* is set to 0. The *Channel* control in the *Converter Stream, Channel Verb* should be set to 0, although any setting of this register gives the same behaviour in mono mode.

ILLEGAL REGISTER VALUES

Should the user set verb registers to illegal, unsupported or reserved values, WM8850 behaviour is undefined.

Writing to Reserved registers has no effect.

RESPONSE FIELD

Valid Bit

Bit [35] of the Response Field is defined as the Valid Bit. Section 7.3.1 of the HDA specification states: "A 1 in the Valid bit position indicates the Response Filed contains a valid response, which the controller will place in the RIRB; a 0 indicates there is no response."

The WM8850 will set the Valid Bit for all responses, except null responses.

We define a null response as a response to a command that contains an invalid verb (a command where NID=0h, and Verb=0h), or a response to a command with a CODEC address (CAd) that does not match the WM8850 CAd. Either of these commands can be considered as a null command.

We define a non-defined command as a command that has no meaning (i.e. a NID that is not within the WM8850, or a Verb ID that is not supported for the given node). The WM8850 will set the Valid Bit for non-defined commands.

CHIP HIERARCHY

WIDGET DIAGRAM

Figure 4 below shows the widgets for the WM8850 CODEC, showing available audio routing options. The Node ID (NID) values are shown in the top right corner of each widget. Dotted lines indicate paths that are controlled by vendor-specific verbs.

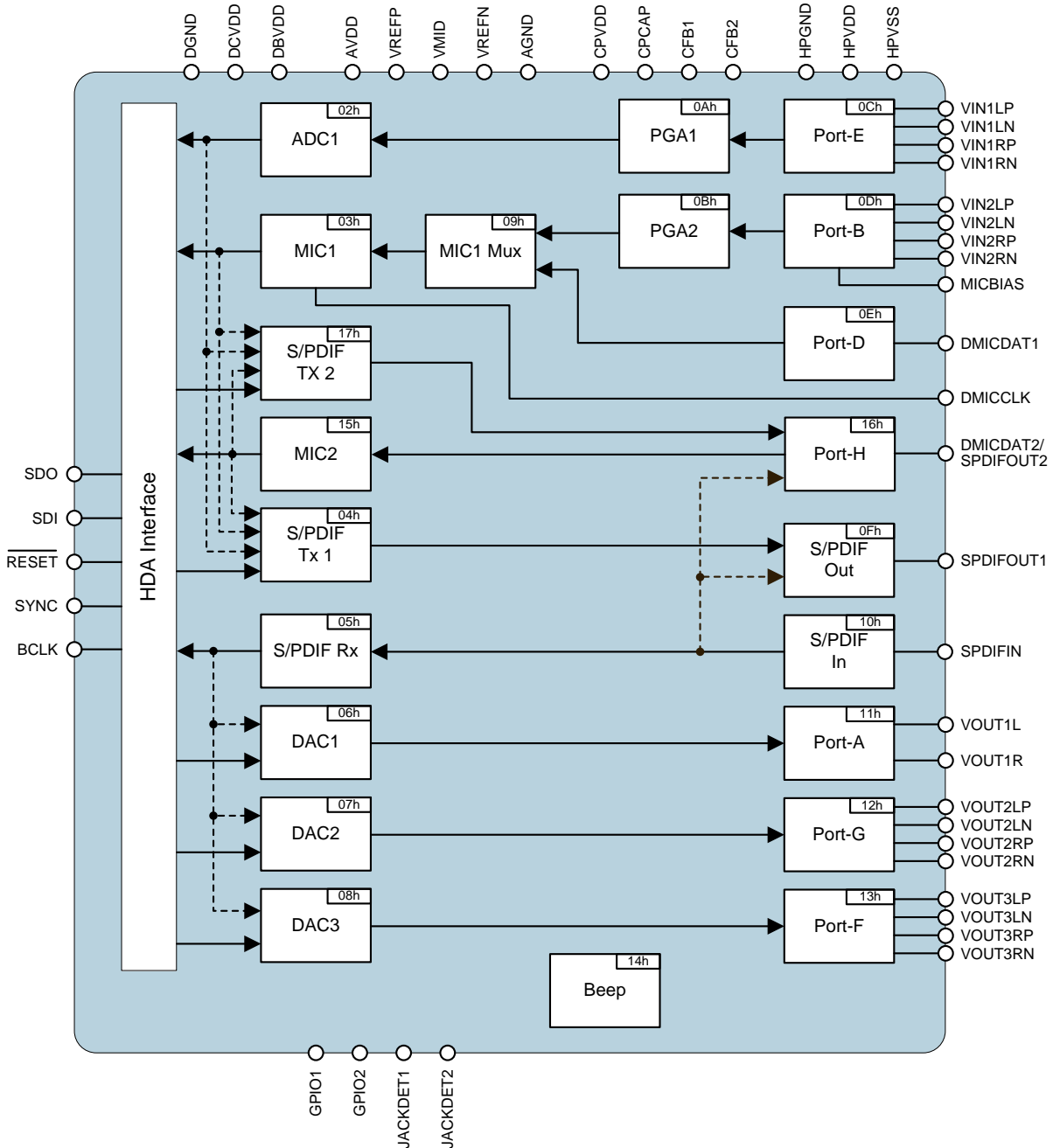

Figure 4 Widget Diagram Showing Valid Audio Paths

NODE LIST

A summary of the capabilities of each node is given in Table 3 below:

NID	NAME	WIDGET TYPE	DESCRIPTION
00h	Root	Root	Provides Vendor ID, Device ID, and NID of the AFG.
01h	AFG	Audio Function Group	Provides the number of Widget Nodes, and NID of first Widget Node. Describes CODEC Audio capabilities.
02h	ADC1	Audio Input Converter	Supports sample rates from 8kHz to 96kHz, and sample sizes from 16-bits to 24-bits.
03h	MIC1	Audio Input Converter	Supports sample rates from 8kHz to 48kHz, and sample sizes from 16-bits to 24-bits.
04h	S/PDIF Tx 1	Audio Output Converter	Supports sample rates from 32kHz to 192kHz, and sample sizes from 16-bits to 32-bits. Includes a fully asynchronous SRC.
05h	S/PDIF Rx	Audio Input Converter	As S/PDIF Tx 1, plus error detection.
06h	DAC1	Audio Output Converter	Supports sample rates from 8kHz to 192kHz, and sample sizes from 16-bits to 24-bits. Supports digital attenuation from 0dB to -63.5 dB in 0.5 dB steps.
07h	DAC2	Audio Output Converter	As DAC1.
08h	DAC3	Audio Output Converter	As DAC1.
09h	MIC1 Mux	Audio Selector	Selects between Digital Mic (Port-D), and Analogue Mic (Port-B).
0Ah	PGA1	Audio Selector	Supports a gain range of -12dB to +12 dB in 0.5dB steps.
0Bh	PGA2	Selector	As PGA1.
0Ch	Port-E	Pin Complex	Line Input (VIN1) with presence detection.
0Dh	Port-B	Pin Complex	Analogue Mic Input (VIN2) with pre-amplifier (0dB, +10dB, +20dB, +30dB), configurable V_{REF} , presence detection and custom impedance sensing scheme.
0Eh	Port-D	Pin Complex	Digital Mic Input (DMIC1) with gain (-12dB to +32dB in 0.5dB steps).
0Fh	S/PDIF Out	Pin Complex	S/PDIF Output with presence detection.
10h	S/PDIF In	Pin Complex	S/PDIF Input with presence detection ^(Note 1) plus lock and rate detection.
11h	Port-A	Pin Complex	Ground-referenced headphone/line out (VOUT1) with presence detection.
12h	Port-G	Pin Complex	Differential line out (VOUT2) with presence detection.
13h	Port-F	Pin Complex	Differential line out (VOUT3) with presence detection.
14h	Beep	Beep Generator	Generates a configurable tone that can be muxed into DAC audio paths. Supports a gain range 0dB to -24dB in 6dB steps.
15h	MIC2	Audio Input Converter	Supports sample rates from 8kHz to 48kHz, and sample sizes from 16-bits to 24-bits.
16h	Port-H	Pin Complex	Digital Mic Input (DMIC2) with gain (-12 dB to 32dB in 0.5 dB steps). Output port for S/PDIF Tx 2.
17h	S/PDIF Tx 2	Audio Output Converter	Supports sample rates from 32kHz to 192kHz, and sample sizes from 16-bits to 32-bits.

Table 3 Node List

Notes:

1. The Pin Sense Verb in the SPDIF_IN node does not convey presence detect information, and is used to convey the status of the SPDIF Rx Lock flag.
2. All Widget Nodes are as defined in the HDA specification; there are no vendor defined widgets.

NODE/VERB SUMMARY

Table 4 gives a summary of the verbs available for each node in the WM8850. Shaded cells show vendor-specific verbs:

	Root Node	AFG Node	ADC1	MIC1	S/PDIF Tx 1	S/PDIF Rx	DAC1	DAC2	DAC3	MIC1 Mux	PGA1	PGA2	Port-E	Port-B	Port-D	S/PDIF Out	S/PDIF In	Port-A	Port-G	Port-F	Beep	MIC2	Port-H	S/PDIF Tx 2
	00h	01h	02h	03h	04h	05h	06h	07h	08h	09h	0Ah	0Bh	0Ch	0Dh	0Eh	0Fh	10h	11h	12h	13h	14h	15h	16h	17h
Reset Get: – Execute: 7FFh		X																						
Stream Format Get: Ah Set: 2h			X	X	X	X	X	X	X													1		X
Amplifier Gain/Mute Get: Bh Set: 3h							X	X	X		X	X		X	X						X		X	
Get Parameter Get: F00h Set: –	X	X	X	X	X	X	X	X	X	X	X	X	X	X	X	X	X	X	X	X	X	X	X	X
Connection Select Control Get: F01h Set: 701h										X														
Get Connection List Entry Get: F02h Set: –			X	X		X				X	X	X				X		X	X	X		X	X	
Processing State Get: F03h Set: 703h			X	X	X	X																X		
Power State Get: F05h Set: 705h		X	X	X			X	X	X															
Converter Stream, Channel Verb Get: F06h Set: 706h			X	X	X	X	X	X	X													X		X
Pin Widget Control Get: F07h Set: 707h													X	X	X	X	X	X	X	X			X	
Unsolicited Response Get: F08h Set: 708h		X	X	X	X	X	X	X	X				X	X		X	X	X	X	X		X		X
Pin Sense Get: F09h Execute: 709h													2	X		2	4	2	2	2				
Beep Generation Get: F0Ah Set: 70Ah																					X			
EAPD/BTL Enable Get: F0Ch Set: 70Ch													X	X										
Digital Converter Control Get: F0Dh Set: 70Dh, 70Eh					X	3																		X
GPIO Data Get: F15h Set: 715h		X																						
GPIO Enable Get: F16h Set: 716h		X																						
GPIO Direction Get: F17h Set: 717h		X																						
GPIO Wake Enable Get: F18h Set: 718h		X																						
GPIO Unsolicited Enable Mask Get: F19h Set: 719h		X																						
GPIO Sticky Mask Get: F1Ah Set: 71Ah		X																						
Configuration Default Get: F1Ch Set: 71Ch, 71Dh, 71Eh, 71Fh													X	X	X	X	X	X	X	X			X	
Implementation Identification/Subsystem ID Get: F20h Set: 720h, 721h, 722h, 723h		X																						
VMID Control Get: F71h Set: 771h		X																						
Beep Mask Selection Get: F72h Set: 772h																					X			
Internal Path Get: F73h Set: 773h				X			X	X	X							X							X	X
S/PDIF Get: F80h Set: 780h				X	1																			
Tx Channel Status Control Get: F81h Set: 781h, 782h, 783h, 784h				X																				X
Channel Status Data Packing Configuration Get: F85h Set: 785h				X																				X

	Root Node	AFG Node	ADC1	MIC1	S/PDIF Tx 1	S/PDIF Rx	DAC1	DAC2	DAC3	MIC1 Mux	PGA1	PGA2	Port-E	Port-B	Port-D	S/PDIF Out	S/PDIF In	Port-A	Port-G	Port-F	Beep	MIC2	Port-H	S/PDIF Tx 2
	00h	01h	02h	03h	04h	05h	06h	07h	08h	09h	0Ah	0Bh	0Ch	0Dh	0Eh	0Fh	10h	11h	12h	13h	14h	15h	16h	17h
GPIO Automatic Control Get: F86h Set: 786h		X																						
Unsolicited Response Priority Control Get: F8Eh Set: 78Eh		X	X	X	X	X	X	X	X				X	X		X	X	X	X	X		X		X
Get Channel Status Get: F91h Set: –						X																		
Get Non-Audio Flag Get: F92h Set: –						X																		
Sample Overwrite Control Get: F93h Set: 793h						X																		
Get S/PDIF In Status Get: FA0h Set: –																	X							
S/PDIF In Control Get: FA1h Set: 7A1h																	X							
Differential Get: FA3h Set: 7A3h														X										
Auto-Mute Control Get: FB0h Set: 7B0h													X	X										
Channel Copy Get: FB1h Set: 7B1h			X	X																		X		
PGA Control Get: FB2h Set: 7B2h, 7B3h											X	X												

Table 4 Node/Verb Summary
Note:

1. Set Verbs are not supported in these cases.
2. Execute Verbs are not supported in these cases.
3. Set Verb 70Eh is not supported by this node.
4. The Pin Sense Verb in the SPDIF_IN node does not convey presence detect information, and is used to convey the status of the SPDIF Rx Lock flag.

DEVICE DESCRIPTION

This section of the datasheet provides detailed information on all the major paths through the device, along with the nodes used and the vendor-specific verbs. For those verbs implemented in the WM8850 which are as defined in the High Definition Audio Specification Revision 1.0 there is no detailed text describing their use in this datasheet.

The functions covered in this section of the datasheet, and the WM8850 nodes associated with each, are listed in Table 5.

FUNCTION	NODE NAME	NODE ID (NID)
Stereo Analogue Line Record	Port-E	0Ch
	PGA1	0Ah
	ADC1	02h
Stereo Analogue Microphone Record	Port-B	0Dh
	PGA2	0Bh
	MIC1 Mux	09h
	MIC1	03h
Digital Microphone Record	Port-D	0Eh
	MIC1 Mux	09h
	MIC1	03h
	Port-H	16h
	MIC2	15h
Stereo Headphone Playback	DAC1	06h
	Port-A	11h
Stereo Line Playback	DAC2	07h
	Port-G	12h
	DAC3	08h
	Port-F	13h
S/PDIF Receive	S/PDIF In	10h
	S/PDIF Rx	05h
S/PDIF Transmit	S/PDIF Tx 1	04h
	S/PDIF Out	0Fh
	S/PDIF Tx 2	17h
	Port-H	16h
Ancillary Functions (Beep generator, VMID control, GPIO2 automatic control mode, Unsolicited response priority control)	Beep	14h
	AFG	01h

Table 5 WM8850 Device Functions

STEREO ANALOGUE LINE RECORD

Stereo analogue line input is supported using the VIN1LP, VIN1LN, VIN1RP and VIN1RN pins; these are available for high-quality stereo digitisation through the ADC1 node.

The WM8850 nodes associated with this function are shown in Figure 5.

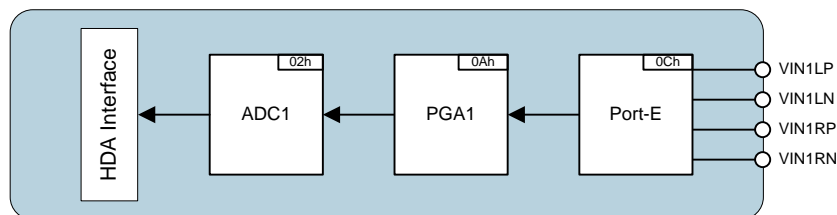

Figure 5 Stereo Analogue Line Record Path

This section provides a summary of the Port-E, PGA1 and ADC1 nodes, and describes the vendor-specific verb functions associated with each.

PORT-E (NID = 0CH)

Table 6 gives a summary of the Port-E node:

NODE SUMMARY INFORMATION	
NID	0Ch
Widget Type	Pin Complex
Supported Get Verbs	F00h, F07h, F08h, F09h, F0Ch, F1Ch, F8Eh, FB0h
Supported Set Verbs	707h, 708h, 70Ch, 71Ch, 71Dh, 71Eh, 71Fh, 78Eh, 7B0h
Unsolicited Responses	Presence Detect Status Change
Vendor-Specific Verbs	F8Eh, 78Eh : Unsolicited Response Priority Control Verb FB0h, 7B0h : Auto-Mute Control Verb

Table 6 Port-E Node Summary Information

Port-E supports two different input configurations, controlled by the *EAPD/BTL Verb*.

SET VERB	BIT	BITFIELD NAME	DEFAULT	DESCRIPTION
70Ch	0	BTL	1h	Controls the configuration of the input pins on Port-E: 0 = Single-ended mode 1 = BTL (balanced) mode

In single-ended input mode, VIN1LP and VIN1RP are used as the Port-E input pins VIN1LN and VIN1RN must be left floating in this mode. Note that the full-scale input signal level is reduced in single-ended mode, as shown in the “Electrical Characteristics” section.

In differential input mode, VIN1LP, VIN1LN, VIN1RP and VIN1RN are used as the Port-E input pins.

See Figure 6 for examples of the external connections required in each of the supported input configurations.

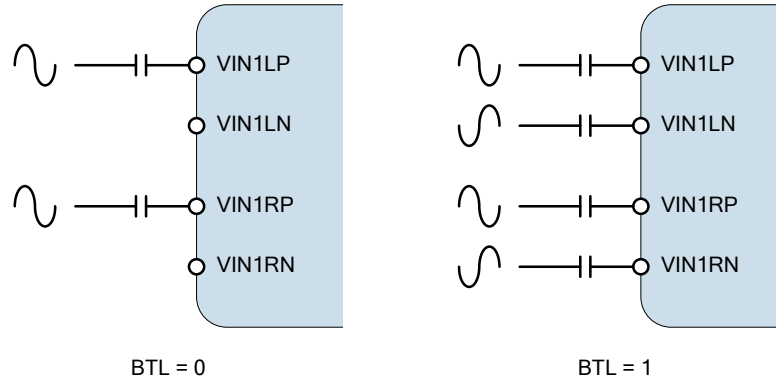

Figure 6 Single Ended (Left) and Differential (Right) External Connections

Port-E supports presence detect. This can be read directly from the *Pin Sense Verb*.

If nothing is plugged into Port-E it is possible to use an automute function which will automatically replace the samples in the stream with zeros, thus avoiding any noise being transmitted when there is no input. This function can be enabled using the vendor-specific *Auto-Mute Control Verb*.

SET VERB	BIT	BITFIELD NAME	DEFAULT	DESCRIPTION
7B0h	0	PD_ AUTOMUTE	0h	Auto-Mute Control: 0 = Automute disabled 1 = Automute enabled Note: When PD_AUTOMUTE=1 and Presence Detect (bit 31 in verb F09h)=1 the WM8850 will replace the samples in the stream with zeros

PGA1 (NID = 0Ah)

Table 7 gives a summary of the PGA1 node:

NODE SUMMARY INFORMATION	
NID	0Ch
Widget Type	Audio Selector
Supported Get Verbs	Bh, F00h, F02h, FB2h
Supported Set Verbs	3h, 7B2h, 7B3h
Unsolicited Responses	None
Vendor-Specific Verbs	FB2h, 7B2h, 7B3h : PGA Control

Table 7 PGA1 Node Summary Information

PGA1 provides analogue gain for the inputs to Port-E, allowing the signal level to be adjusted by up to +/-12dB in 0.5dB steps. Gain can be applied to left and right channels independently if required. Additionally, a mute function is available – again this can be applied to separate channels as required. The gain of PGA1 is controlled using the *Amplifier Gain/Mute Verb*.

Note: When Port-E is configured in single-ended mode the actual gain settings applied to the signal will be adjusted by a further -3.0dB. This changes the effective gain range to -15dB to +9dB.

PGA1 uses an internal zero cross detect circuit to ensure that all gain changes occur while the signal passes through the zero point. This function eliminates any potential DC steps that can occur if gain changes are applied at other times, and therefore the potential for zipper noise is removed. If no zero cross occurs within a specified time after the gain change is requested via a register write a timeout period will elapse and the gain will be changed regardless. This timeout period can be changed using the vendor-specific *PGA Control Verb*:

SET VERB	BIT	BITFIELD NAME	DEFAULT	DESCRIPTION
7B2h 7B3h	13:0	Terminal Count	1FFFh	Set the period of the zero detect timeout clock: 0000h = Timeout disabled 0001h to 03FFh = Reserved 0400h = 1025 x 20.833µs (21.3ms) 0401h = 1026 x 20.833µs (21.4ms) ... 1FFFh = 8192 x 20.833µs (171ms) ... 3FFFh = 16384 x 20.833µs (341ms) Note: The timeout clock uses the SYNC signal from the HDA interface, so the absolute value of the timeout period will depend on the absolute accuracy of the SYNC signal.

ADC1 (NID = 02h)

Table 8 gives a summary of the ADC1 node:

NODE SUMMARY INFORMATION	
NID	02h
Widget Type	Audio Input Converter
Supported Get Verbs	Ah, F00h, F02h, F03h, F05h, F06h, F08h, F8Eh, FB1h
Supported Set Verbs	2h, 703h, 705h, 706h, 708h, 78Eh, 7B1h
Unsolicited Responses	Stream Drop
Vendor-Specific Verbs	F8Eh, 78Eh : Unsolicited Response Priority Control Verb FB1h, 7B1h : Channel Copy Verb

Table 8 ADC1 Node Summary Information

ADC1 supports all common sample rates from 8kHz to 96kHz and data widths of 16, 20, 24 and 32-bit (Float-32).

The sample rate and word length of the data captured by the ADC1 node is set using the *Stream Format Verb*. Table 9 below shows the required settings for *Base*, *Mult* and *Div* as part of the *Stream Format Verb* to obtain the required sample rate.

SAMPLE RATE	BASE	MULT	DIV
8kHz	0h	0h	5h
11.025kHz	1h	0h	3h
16kHz	0h	0h	2h
22.05kHz	1h	0h	1h
24kHz	0h	0h	1h
32kHz	0h	1h	2h
44.1kHz	1h	0h	0h
48kHz	0h	0h	0h
88.2kHz	1h	1h	0h
96kHz	0h	1h	0h

Table 9 ADC1 Supported Sample Rate Settings

Note: Other settings of *Base*, *Mult* and *Div* are reserved and should not be set.

The ADC1 output data is by default set to provide the captured waveform from the left channel in Channel 0, and the right channel in Channel 1. It is possible to adjust this mapping using the vendor-specific *Channel Copy Verb*.

SET VERB	BIT	BITFIELD NAME	DEFAULT	DESCRIPTION
7B1h	1	CHAN1_SEL	1	Channel 1 (right) Mapping Control: 0 = Channel 1 takes data from left audio channel 1 = Channel 1 takes data from right audio channel
	0	CHAN0_SEL	0	Channel 0 (left) Mapping Control: 0 = Channel 0 takes data from left audio channel 1 = Channel 0 takes data from right audio channel

STEREO ANALOGUE MICROPHONE RECORD

Stereo analogue microphone input is supported using the VIN2LP, VIN2LN, VIN2RP and VIN2RN pins; these are available for analogue microphone digitisation through the MIC1 node. The MICBIAS output, controlled via the Port-B node, provides a low noise voltage output suitable for use as a power supply for analogue or digital microphones.

The WM8850 nodes associated with this function are shown in Figure 7.

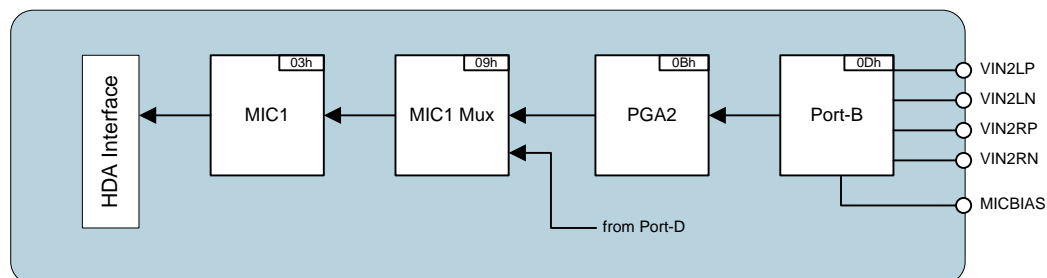

Figure 7 Stereo Analogue Microphone Record Path

This section provides a summary of the Port-B, PGA2, MIC1 Mux and MIC1 nodes, and describes the vendor-specific functions associated with each.

PORT-B (NID = 0DH)

Table 10 gives a summary of the Port-B node:

NODE SUMMARY INFORMATION	
NID	0Dh
Widget Type	Pin Complex
Supported Get Verbs	Bh, F00h, F07h, F08h, F09h, F0Ch, F1Ch, <i>F8Eh, FA3h, FB0h</i>
Supported Set Verbs	3h, 707h, 708h, 70Ch, 71Ch, 71Dh, 71Eh, 71Fh, <i>78Eh, 7A3h, 7B0h</i>
Unsolicited Responses	Presence Detect Status Change Impedance Measurement Ready
Vendor-Specific Verbs	F8Eh, 78Eh : Unsolicited Response Priority Control Verb FA3h, 7A3h : Differential Verb FB0h, 7B0h : Auto-Mute Control Verb

Table 10 Port-B Node Summary Information

Port-B supports three different input configurations, controlled by the *EAPD/BTL Verb* and the vendor-specific *Differential Verb*.

SET VERB	BIT	BITFIELD NAME	DEFAULT	DESCRIPTION
70Ch	0	BTL	1h	Controls the configuration of the input pins on Port-E: 0 = Single-ended mode 1 = BTL (balanced) mode
7A3h	0	Differential Mode	0h	Differential mode: 0 = Differential (microphone) 1 = Pseudo-differential

The supported input configurations are described in Table 11 below:

BTL	DIFFERENTIAL MODE	MODE	ACTIVE PINS	NOTES
0	X	Single Ended	VIN2LP VIN2RP	Input impedance varies with gain setting – minimum 10kΩ Suitable for microphone or line level signals
1	0	Differential (Microphone)	VIN2LP VIN2LN VIN2RP VIN2RN	Input impedance does not vary with gain setting – typically 120kΩ Suitable for microphone (low-level) signals only
1	1	Pseudo-Differential	VIN2LP VIN2LN VIN2RP VIN2RN	Input impedance varies with gain setting – minimum 10kΩ Suitable for microphone or line level signals

Table 11 Port-B Configuration Options

See Figure 8 for examples of the external connections required in each of the supported input configurations.

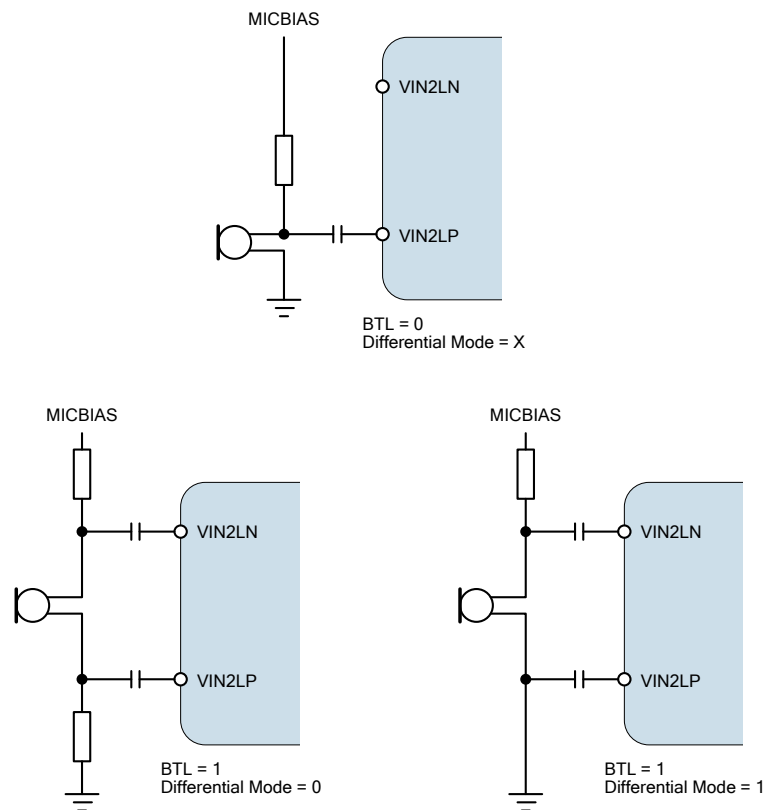

Figure 8 Port-B Example External Connections (one channel shown)

A microphone pre-amplifier is available as part of the Port-B node. This amplifier can be used to boost microphone inputs by +10dB, +20dB or +30dB. Alternatively, the gain of the pre-amplifier can be set to 0dB. It is not possible to use different gain settings for the left and right channels, and the pre-amplifier does not support mute. The microphone pre-amplifier is controlled by the *Amplifier Gain/Mute Verb*.

A low-noise microphone bias generator is provided as part of Port-B, which is suitable for use as a bias supply for analogue microphones. The control of the microphone bias level is via the *Pin Widget Control Verb*.

Port-B supports impedance sensing when using the microphone bias generator; this can be read directly from the *Pin Sense Verb*. Port-B also supports presence detect, using the *Pin Sense Verb*.

If nothing is plugged into Port-B it is possible to use an automute function which will automatically replace the samples in the stream with zeros, thus avoiding any noise being transmitted when there is no input device connected. This function can be enabled using the vendor-specific *Auto-Mute Control Verb*.

SET VERB	BIT	BITFIELD NAME	DEFAULT	DESCRIPTION
7B0h	0	PD_ AUTOMUTE	0h	Auto-Mute Control: 0 = Automute disabled 1 = Automute enabled Note: When PD_AUTOMUTE=1 and Presence Detect (bit 31 in verb F09h)=1 the WM8850 will replace the samples in the stream with zeros

PGA2 (NID = 0Bh)

Table 12 gives a summary of the PGA2 node:

NODE SUMMARY INFORMATION	
NID	0Ch
Widget Type	Audio Selector
Supported Get Verbs	Bh, F00h, F02h, FB2h
Supported Set Verbs	3h, 7B2h, 7B3h
Unsolicited Responses	None
Vendor-Specific Verbs	FB2h, 7B2h, 7B3h : PGA Control Verb

Table 12 PGA2 Node Summary Information

PGA2 provides analogue gain for the inputs to Port-B, allowing the signal level to be adjusted by up to +/-12dB in 0.5dB steps. Gain can be applied to left and right channels independently if required. Additionally, a mute function is available – again this can be applied to separate channels as required. The gain of PGA2 is controlled using the *Amplifier Gain/Mute Verb*.

PGA2 uses an internal zero cross detect circuit to ensure that all gain changes occur while the signal passes through the zero point. This function eliminates any potential DC steps that can occur if gain changes are applied at other times, and therefore the potential for zipper noise is removed. If no zero cross occurs within a specified time after the gain change is requested via a register write a timeout period will elapse and the gain will be changed regardless. This timeout period can be changed using the vendor-specific *PGA Control Verb*.

SET VERB	BIT	BITFIELD NAME	DEFAULT	DESCRIPTION
7B2h 7B3h	13:0	Terminal Count	1FFFh	<p>Set the period of the zero detect timeout clock: 0000h = Timeout disabled 0001h to 03FFh = Reserved 0400h = 1025 x 20.833µs (21.3ms) 0401h = 1026 x 20.833µs (21.4ms) ... 1FFFh = 8192 x 20.833µs (171ms) ... 3FFFh = 16384 x 20.833µs (341ms)</p> <p>Note: The timeout clock uses the SYNC signal from the HDA interface, so the absolute value of the timeout period will depend on the absolute accuracy of the SYNC signal.</p>

MIC1 MUX (NID = 09h)

Table 13 gives a summary of the MIC1 Mux node:

NODE SUMMARY INFORMATION	
NID	09h
Widget Type	Audio Selector
Supported Get Verbs	F00h, F01h, F02h
Supported Set Verbs	701h
Unsolicited Responses	None

Table 13 MIC1 Mux Node Summary Information

MIC1 Mux is used to select the source of the input to the MIC1 node. This can be either from the analogue microphone input path (from PGA2), or from the digital microphone path (from Port-D). When the MIC1 Mux is selecting the digital microphone input (Port-D) the WM8850 is automatically configured to bypass the analogue to digital converter part of the MIC1 node (NID = 03h).

There are no vendor-specific verbs associated with the MIC1 Mux node.

MIC1 (NID = 03H)

Table 14 gives a summary of the MIC1 node:

NODE SUMMARY INFORMATION	
NID	02h
Widget Type	Audio Input Converter
Supported Get Verbs	Ah, F00h, F02h, F03h, F05h, F06h, F08h, <i>F8Eh, FB1h</i>
Supported Set Verbs	2h, 703h, 705h, 706h, 708h, <i>78Eh, 7B1h</i>
Unsolicited Responses	Stream Drop
Vendor-Specific Verbs	F8Eh, 78Eh : Unsolicited Response Priority Control Verb FB1h, 7B1h : Channel Copy Verb

Table 14 MIC1 Node Summary Information

MIC1 contains a high performance stereo ADC intended for capture of microphone inputs to the WM8850. MIC1 supports all common sample rates from 8kHz to 48kHz and data widths of 16, 20, 24 and 32-bit (Float-32). The actual processing used by this node is dependant on the type of input received from the MIC1 Mux (NID = 09h), as the input to MIC1 may come from either an analogue or digital microphone.

Regardless of the type of input, the sample rate and word length of the data captured by the MIC1 node is set using the *Stream Format Verb*. Table 15 below shows the required settings for *Base*, *Mult* and *Div* as part of the *Stream Format Verb* to obtain the required sample rate.

When a digital microphone is being used, the DMICCLK output frequency will be set according to the *Stream Format Verb*. See “Digital Microphone Record” for details of the DMICCLK frequency.

SAMPLE RATE	BASE	MULT[2:0]	DIV[2:0]
8kHz	0h	0h	5h
11.025kHz	1h	0h	3h
16kHz	0h	0h	2h
22.05kHz	1h	0h	1h
32kHz	0h	1h	2h
44.1kHz	1h	0h	0h
48kHz	0h	0h	0h

Table 15 MIC1 Supported Sample Rate Settings

Note: Other settings of *Base*, *Mult* and *Div* are reserved and should not be set.

The MIC1 output data is by default set to provide the captured waveform from the left channel in Channel 0, and the right channel in Channel 1. It is possible to adjust this mapping using the vendor-specific *Channel Copy Verb*.

SET VERB	BIT	BITFIELD NAME	DEFAULT	DESCRIPTION
7B1h	1	CHAN1_SEL	1	Channel 1 (right) Mapping Control: 0 = Channel 1 takes data from left audio channel 1 = Channel 1 takes data from right audio channel
	0	CHAN0_SEL	0	Channel 0 (left) Mapping Control: 0 = Channel 0 takes data from left audio channel 1 = Channel 0 takes data from right audio channel

DIGITAL MICROPHONE RECORD

Digital microphone input is supported using the DMICDAT1, DMICDAT2 and DMICCLK pins; these allow up to four independent digital microphones to be connected through the MIC1 and MIC2 nodes.

The digital microphone interface accepts unfiltered PDM on the DMICDAT1 and DMICDAT2 pins and can recover data from both the high and low periods of the DMICCLK. Two microphone channels are interleaved on DMICDAT1; another two channels are interleaved on DMICDAT2. The timing is illustrated in Figure 9. Each microphone must tri-state its data output when the other microphone is transmitting.

Note that the DMICDAT2 pin also supports the SPDIFOUT2 function, which is described in the “S/PDIF Transmit” section.

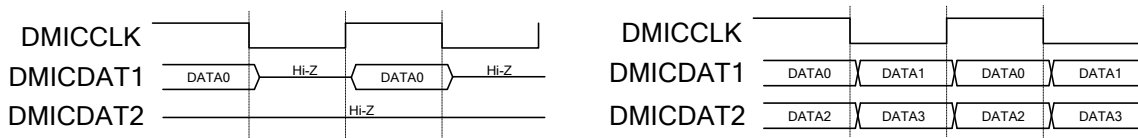

Figure 9 Digital Microphone Interface Protocol for One (left) or Four (right) Microphones

The WM8850 nodes associated with this function are shown in Figure 10.

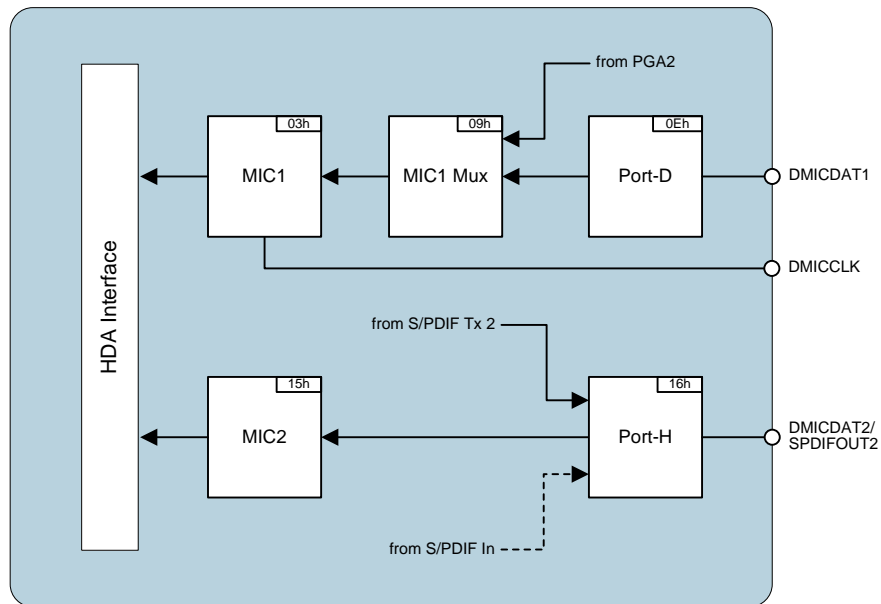

Figure 10 Digital Microphone Record Path

This section provides a summary of the Port-D, Port-H and MIC2 nodes, and describes the vendor-specific verb functions associated with each.

The MIC1 Mux and MIC1 nodes are described in the “Stereo Analogue Microphone Record” section.

PORT-D (NID = 0Eh)

Table 16 gives a summary of the Port-D node:

NODE SUMMARY INFORMATION	
NID	0Eh
Widget Type	Pin Complex
Supported Get Verbs	Bh, F00h, F07h, F1Ch
Supported Set Verbs	3h, 707h, 71Ch, 71Dh, 71Eh, 71Fh
Unsolicited Responses	None

Table 16 Port-D Node Summary Information

Port-D provides digital gain for the microphone(s) connected to DMICDAT1, allowing the signal level to be adjusted by up to +32dB to -12dB in 0.5dB steps. Gain can be applied to left and right channels independently if required. Additionally, a mute function is available – again this can be applied to separate channels as required. The gain is controlled using the *Amplifier Gain/Mute Verb*.

There are no vendor-specific verbs associated with the Port-D node.

PORT-H (NID = 16H)

Table 17 gives a summary of the Port-H node:

NODE SUMMARY INFORMATION	
NID	16h
Widget Type	Pin Complex
Supported Get Verbs	Bh, F00h, F02h, F07h, F1Ch, <i>F73h</i>
Supported Set Verbs	3h, 707h, 71Ch, 71Dh, 71Eh, 71Fh, <i>773h</i>
Unsolicited Responses	None
Vendor-Specific Verbs	<i>F73h, 773h</i> : Internal Path Verb

Table 17 Port-H Node Summary Information

Port-H provides digital gain for the microphone(s) connected to DMICDAT2, allowing the signal level to be adjusted by up to +32dB to -12dB in 0.5dB steps. Gain can be applied to left and right channels independently if required. Additionally, a mute function is available – again this can be applied to separate channels as required. The gain is controlled using the *Amplifier Gain/Mute Verb*.

Note that Port-H can also be used to provide a S/PDIF output. For details of the use of the node as a S/PDIF output, see the “S/PDIF Transmit” section.

When Port-H is configured for S/PDIF output, it is possible to select either S/PDIF In or S/PDIF Tx 2 as the data source. The signal path is selected using vendor-specific *Internal Path Verb*.

SET VERB	BIT	BITFIELD NAME	DEFAULT	DESCRIPTION
773h	7:0	Path Sel	17h	Selects the source of the Port-H node: 10h = S/PDIF In 17h = S/PDIF Tx2

MIC2 (NID = 15h)

Table 18 gives a summary of the MIC2 node:

NODE SUMMARY INFORMATION	
NID	15h
Widget Type	Audio Input Converter
Supported Get Verbs	Ah, F00h, F02h, F03h, F06h, F08h, <i>F8Eh, FB1h</i>
Supported Set Verbs	703h, 706h, 708h, <i>78Eh, 7B1h</i>
Unsolicited Responses	Stream Drop
Vendor-Specific Verbs	F8Eh, 78Eh : Unsolicited Response Priority Control Verb FB1h, 7B1h : Channel Copy Verb

Table 18 MIC2 Node Summary Information

The MIC2 node supports digital audio input at all common sample rates from 8kHz to 48kHz.

Note that the *Stream Format Verb* in the MIC2 widget (NID = 15h) is read-only; the associated parameters will echo the values set in the same verb in the MIC1 widget.

The MIC2 output data is by default set to provide the captured waveform from the left channel in Channel 0, and the right channel in Channel 1. It is possible to adjust this mapping using the vendor-specific *Channel Copy Verb*:

SET VERB	BIT	BITFIELD NAME	DEFAULT	DESCRIPTION
7B1h	1	CHAN1_SEL	1	Channel 1 (right) Mapping Control: 0 = Channel 1 takes data from left audio channel 1 = Channel 1 takes data from right audio channel
	0	CHAN0_SEL	0	Channel 0 (left) Mapping Control: 0 = Channel 0 takes data from left audio channel 1 = Channel 0 takes data from right audio channel

DIGITAL MICROPHONE INTERFACE CLOCK RATES

The sample rate of data captured by the digital microphone interface is controlled by the *Stream Format Verb* in the MIC1 widget (NID = 03h). Note that the *Stream Format Verb* in the MIC2 widget (NID = 15h) will echo the values set in the same verb in the MIC1 widget. This is necessary as DMICCLK is shared between the DMICDAT1 and DMICDAT2 pins.

The DMICCLK frequency will output at the rates shown in Table 19, which also contains the required settings for *Base*, *Mult* and *Div* as part of the *Stream Format Verb* of the MIC1 widget to obtain the required sample rate:

SAMPLE RATE	BASE	MULT[2:0]	DIV[2:0]	DMICCLK FREQUENCY	PROCESSING RATE
8kHz	0h	0h	5h	1.024MHz	128fs
11.025kHz	1h	0h	3h	1.4112MHz	128fs
16kHz	0h	0h	2h	1.024MHz	64fs
22.05kHz	1h	0h	1h	1.4112MHz	64fs
32kHz	0h	1h	2h	2.048MHz	64fs
44.1kHz	1h	0h	0h	2.8224MHz	64fs
48kHz	0h	0h	0h	3.072MHz	64fs

Table 19 MIC1 Supported Sample Rate Settings for Digital Microphone Interface

Note: Other settings of *Base*, *Mult* and *Div* are reserved and should not be set.

STEREO HEADPHONE PLAYBACK

Stereo headphone playback is supported using the VOUT1L and VOUT1R pins; these provide a ground-referenced stereo output through the DAC1 node. This output is intended for headphones, but can be used as a single-ended line output if required. This path can provide two channels of a multi-channel playback system, operating alongside the other two DAC paths.

It is possible to configure the stereo headphone outputs to select the S/PDIF Rx node as the data source. This signal path is enabled using a vendor-specific verb, and is illustrated by the dotted line in Figure 11.

The WM8850 nodes associated with this function are shown in Figure 11.

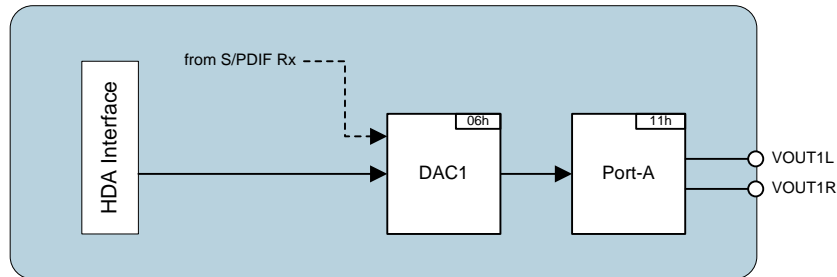

Figure 11 Stereo Headphone Playback Path

This section provides a summary of the DAC1 and Port-A, and describes the vendor-specific verb functions associated with each.

DAC1 (NID = 06H)

Table 20 gives a summary of the DAC1 node:

NODE SUMMARY INFORMATION	
NID	06h
Widget Type	Audio Converter
Supported Get Verbs	Ah, Bh, F00h, F05h, F06h, F08h, F73h, F8Eh
Supported Set Verbs	2h, 3h, 705h, 706h, 708h, 773h, 78Eh
Unsolicited Responses	Stream Error
Vendor-Specific Verbs	F73h, 773h : Internal Path Verb F8Eh, 78Eh : Unsolicited Response Priority Control Verb

Table 20 DAC1 Node Summary Information

DAC1 is a high performance stereo DAC that supports all common sample rates from 8kHz to 192kHz and data widths of 16, 20, 24 and 32-bit (Float-32).

The sample rate and word length of the data played back by the DAC1 node is set using the *Stream Format Verb*. Table 9 below shows the required settings for *Base*, *Mult* and *Div* as part of the *Stream Format Verb* to obtain the required sample rate.

SAMPLE RATE	BASE	MULT	DIV
8kHz	0h	0h	5h
11.025kHz	1h	0h	3h
16kHz	0h	0h	2h
22.05kHz	1h	0h	1h
24kHz	0h	0h	1h
32kHz	0h	1h	2h
44.1kHz	1h	0h	0h
48kHz	0h	0h	0h
88.2kHz	1h	1h	0h
96kHz	0h	1h	0h
176.4kHz	1h	3h	0h
192kHz	0h	3h	0h

Table 21 DAC1 Supported Sample Rate Settings

Note: Other settings of *Base*, *Mult* and *Div* are reserved and should not be set.

DAC1 provides digital gain, allowing the signal level to be adjusted between 0dB and -63.5dB in 0.5dB steps. Gain can be applied to left and right channels independently if required. Additionally, a digital softmute function is available – again this can be applied to separate channels as required. The gain of DAC1 is controlled using the *Amplifier Gain/Mute Verb*.

Note: When Port-A is configured to drive headphones (*H-Phn Enable* = 1) the actual gain settings applied will be adjusted by a further -8.0dB. This changes the effective gain range to -71.5dB to -8.0dB.

Under default conditions, the DAC1 node will process data received from the HDA interface. It is also possible to select S/PDIF Rx as the data source, using the vendor-specific *Internal Path Verb*.

Note that, when the S/PDIF Rx node is selected as the input to any of DAC1, DAC2 or DAC3, the *Internal Path Verbs* in all the other DAC nodes are updated to use the S/PDIF Rx node also. It is not possible to route the HDA Link to any DAC at the same time as routing the S/PDIF Rx node to another DAC.

When the S/PDIF Rx node is selected as the input to the DAC nodes, the *Stream Format Verb* for each DAC node becomes read-only and is set according to the settings in the S/PDIF Rx node.

SET VERB	BIT	BITFIELD NAME	DEFAULT	DESCRIPTION
773h	7:0	Path Sel	00h	Selects source of DAC1 node: 00h = DAC1 takes data from HDA Link 05h = DAC1 takes data from S/PDIF Rx All other values of Path Sel are reserved.

Note: When using the *Internal Path Verb* to use S/PDIF Rx as the data source of DAC1 it is recommended that the S/PDIF Rx node (NID=05h) is enabled after setting Path Sel=05h. Failure to do so may result in a one sample delay between left and right channels.

PORT-A (NID = 11H)

Table 22 gives a summary of the Port-A node:

NODE SUMMARY INFORMATION	
NID	11h
Widget Type	Pin Complex
Supported Get Verbs	F00h, F02h, F07h, F08h, F09h, F1Ch, <i>F8Eh</i>
Supported Set Verbs	707h, 708h, 709h, 71Ch, 71Dh, 71Eh, 71Fh, <i>78Eh</i>
Unsolicited Responses	Presence Detect
Vendor-Specific Verbs	F8Eh, 78Eh : Unsolicited Response Priority Control Verb

Table 22 Port-A Node Summary Information

Port-A contains a ground-referenced headphone driver which negates the requirement for large AC-coupling capacitors commonly required for headphone applications. The headphone driver is powered by an on-board charge pump which generates the required positive and negative supply voltages. Configuration of this block is handled automatically by the WM8850, and the required external components to enable optimum performance of the charge pump are given in the “Applications Information” section.

STEREO LINE PLAYBACK

Stereo line playback is supported using the VOUT2LP, VOUT2LN, VOUT2RP and VOUT2RN pins; these provide a differential stereo output through the DAC2 node. These outputs are intended for line-level loads; the differential configuration provides noise rejection, particularly in the case of lengthy signal tracks. An external differential to single-ended converter should be used for connection to an external stereo jack. This path can provide two channels of a multi-channel playback system, operating alongside the other two DAC paths.

Stereo line playback is also supported using the VOUT3LP, VOUT3LN, VOUT3RP and VOUT3RN pins; these provide a differential stereo output through the DAC3 node. This path is identical in function to the DAC2 path, so both paths are described together here. Note, however, that they are completely independent paths and must be setup separately.

It is possible to configure either of the stereo line outputs to select the S/PDIF Rx node as the data source. These signal paths are enabled using vendor-specific verbs, and are illustrated by the dotted line in Figure 12.

The WM8850 nodes associated with this function are shown in Figure 12.

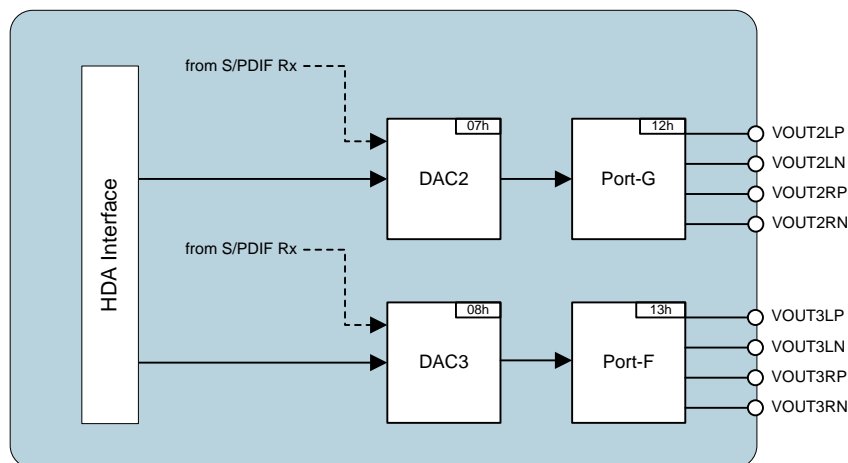

Figure 12 Stereo Differential Line Playback Paths

This section provides a summary of the DAC2, Port-G, DAC3 and Port-F nodes, and describes the vendor-specific verb functions associated with each.

DAC2 (NID = 07h) AND DAC3 (NID = 08h)

Table 23 gives a summary of the DAC2 and DAC3 nodes:

NODE SUMMARY INFORMATION	
NID	07h / 08h
Widget Type	Audio Converter
Supported Get Verbs	Ah, Bh, F00h, F05h, F06h, F08h, <i>F73h, F8Eh</i>
Supported Set Verbs	2h, 3h, 705h, 706h, 708h, <i>773h, 78Eh</i>
Unsolicited Responses	Stream Error
Vendor-Specific Verbs	F73h, 773h : Internal Path Verb F8Eh, 78Eh : Unsolicited Response Priority Control Verb

Table 23 DAC2 and DAC3 Nodes Summary Information

DAC2 and DAC3 are a high performance stereo DACs that supports all common sample rates from 8kHz to 192kHz and data widths of 16, 20, 24 and 32-bit (Float-32).

The sample rate and word length of the data played back by the DAC2 or DAC3 nodes is set using the *Stream Format Verb*. Table 24 below shows the required settings for *Base*, *Mult* and *Div* as part of the *Stream Format Verb* to obtain the required sample rate.

SAMPLE RATE	BASE	MULT	DIV
8kHz	0h	0h	5h
11.025kHz	1h	0h	3h
16kHz	0h	0h	2h
22.05kHz	1h	0h	1h
24kHz	0h	0h	1h
32kHz	0h	1h	2h
44.1kHz	1h	0h	0h
48kHz	0h	0h	0h
88.2kHz	1h	1h	0h
96kHz	0h	1h	0h
176.4kHz	1h	3h	0h
192kHz	0h	3h	0h

Table 24 DAC2 and DAC3 Supported Sample Rate Settings

Note: Other settings of *Base*, *Mult* and *Div* are reserved and should not be set.

DAC2 and DAC3 provide digital gain, allowing the signal level to be adjusted between 0dB and -63.5dB in 0.5dB steps. Gain can be applied to left and right channels independently if required. Additionally, a digital softmute function is available – again this can be applied to separate channels as required. The gain of each DAC is controlled using the *Amplifier Gain/Mute Verb* in the required node.

Under default conditions, the DAC2 and DAC3 nodes will process data received from the HDA interface. It is also possible to select S/PDIF Rx as the data source, using the vendor-specific *Internal Path Verb*.

Note that, when the S/PDIF Rx node is selected as the input to any of DAC1, DAC2 or DAC3, the *Internal Path Verbs* in all the other DAC nodes are updated to use the S/PDIF Rx node also. It is not possible to route the HDA Link to any DAC at the same time as routing the S/PDIF Rx node to another DAC.

When the S/PDIF Rx node is selected as the input to the DAC nodes, the *Stream Format Verb* for each DAC node becomes read-only and is set according to the settings in the S/PDIF Rx node.

SET VERB	BIT	BITFIELD NAME	DEFAULT	DESCRIPTION
773h	7:0	Path Sel	00h	Selects source of DAC2 or DAC3 node: 00h = DAC takes data from HDA Link 05h = DAC takes data from S/PDIF Rx All other values of Path Sel are reserved.

Note: When using the *Internal Path Verb* to use S/PDIF Rx as the data source of DAC2 or DAC3 it is recommended that the S/PDIF Rx node (NID=05h) is enabled after setting Path Sel=05h. Failure to do so may result in a one sample delay between left and right channels.

PORT-G (NID = 12h) AND PORT-F (NID = 13h)

Table 25 gives a summary of the Port-G and Port-F nodes:

NODE SUMMARY INFORMATION	
NID	12h / 13h
Widget Type	Pin Complex
Supported Get Verbs	F00h, F02h, F07h, F08h, F09h, F1Ch, <i>F8Eh</i>
Supported Set Verbs	707h, 708h, 709h, 71Ch, 71Dh, 71Eh, 71Fh, <i>78Eh</i>
Unsolicited Responses	Presence Detect
Vendor-Specific Verbs	F8Eh, 78Eh : Unsolicited Response Priority Control Verb

Table 25 Port-G and Port-F Nodes Summary Information

Port-G and Port-F each contain a VMID-referenced differential line driver which requires AC-coupling if driving outputs directly. It is possible to use the output in a single-ended configuration if required; note that this will result in a drop in signal level of 6dB.

If a single-ended output is required, VOUT2LP (VOUT3LP) and VOUT2RP (VOUT3RP) should be used to connect to the load, and VOUT2LN (VOUT3LN) and VOUT2RN (VOUT3RN) should be left unconnected. There is no requirement to change register settings or provide any additional external components to compensate for the unconnected output pins.

S/PDIF RECEIVE

S/PDIF Receive functionality is supported using the SPDIFIN pin; this provides an IEC-60958-3 compatible S/PDIF input through the S/PDIF Rx node.

The S/PDIF receiver accepts all common audio sample frequencies from 32kHz to 96kHz, and an on-chip fully-asynchronous sample rate converter (SRC) provides the flexibility to interface any supported incoming S/PDIF rate to the HDA interface without loss of quality. The S/PDIF receiver supports readback of all 40-bits of the S/PDIF channel status information, but does not decode the user channel data.

The WM8850 nodes associated with this function are shown in Figure 13:

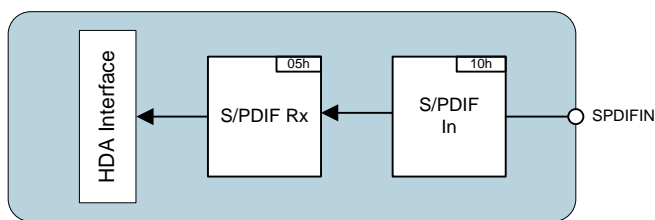

Figure 13 S/PDIF Receive Path

This section provides a summary of the S/PDIF In and S/PDIF Rx nodes, and describes the vendor-specific verb functions associated with each.

S/PDIF IN (NID = 10h)

Table 26 gives a summary of the S/PDIF In node:

NODE SUMMARY INFORMATION	
NID	10h
Widget Type	Pin Complex
Supported Get Verbs	F00h, F07h, F08h, F09h, F1Ch, F8Eh, FA0h, FA1h
Supported Set Verbs	707h, 708h, 71Ch, 71Dh, 71Eh, 71Fh, 78Eh, 7A1h
Unsolicited Responses	Presence Detect Lock Status Recovered Rate Change
Vendor-Specific Verbs	F8Eh, 78Eh : Unsolicited Response Priority Control Verb FA0h : Get S/PDIF In Status Verb FA1h, 7Ah : S/PDIF In Control Verb

Table 26 S/PDIF In Node Summary Information

The S/PDIF In node provides control over the physical connection of the input to the S/PDIF receiver. The node also provides basic status information from the S/PDIF receiver circuitry, such as lock status and recovered sample rate.

The S/PDIF input circuitry accepts signal levels as described in IEC-60958-3, as well as CMOS compatible and low-amplitude CMOS compatible signals. This allows for a wide range of external connectivity to the WM8850 depending on the application, which may range from direct connection of electrical signals from a coaxial cable through a matching network or from another CMOS device like an optical receiver or DSP.

The input configuration for the SPDIFIN pin is controlled by two register bits in the vendor-specific *Get S/PDIF In Control Verb*.

SET VERB	BIT	BITFIELD NAME	DEFAULT	DESCRIPTION
7A1h	1	CMOS Thres	0	Selects the logic threshold levels when in CMOS Mode: 0 = 30% / 70% thresholds 1 = 20% / 40% thresholds
	0	Pin Mode Sel	0	Selects the SPDIFIN Pin mode: 0 = CMOS Mode 1 = Comparator Mode

See Figure 14 for examples of the external connections required in each of the supported S/PDIF input modes:

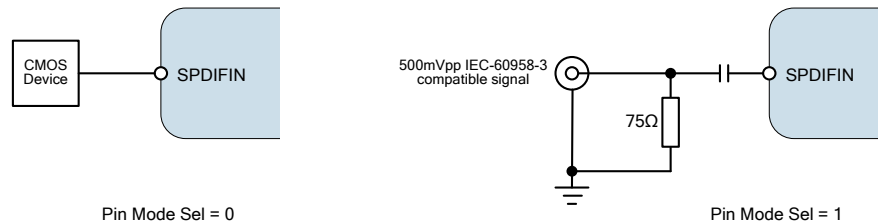

Figure 14 SPDIFIN Example External Connections

The vendor-specific *S/PDIF In Status Verb* can be used to see the current physical status of the S/PDIF receiver. This verb indicates whether the S/PDIF Receiver circuitry is locked, and the sample rate of the incoming S/PDIF stream.

GET VERB	BIT	BITFIELD NAME	DEFAULT	DESCRIPTION
FA0h	3:1	RATE	7h	Recovered sample rate: 0h = Reserved 1h = Reserved 2h = 96 kHz 3h = 88.2 kHz 4h = 48 kHz 5h = 44.1 kHz 6h = 32 kHz 7h = Sample rate not detected
	0	LOCK	0	S/PDIF Rx lock flag: 0 = Unlocked 1 = Locked

Note: The *RATE* value is measured directly from the incoming S/PDIF stream, using the BCLK on the HDA link as a reference clock. The reported sample rate in the channel status of the S/PDIF stream is not used to provide this value, so in a situation where the two differ the *RATE* value in the will reflect the actual sample rate of the S/PDIF input signal. This assumes that the speed of the BCLK on the HDA link is within the acceptable tolerance as defined in the HDA Specification.

If the S/PDIF receiver unlocks and the relocks once a stream is setup, for example as a result of a change in the rate of the S/PDIF signal applied to SPDIFIN pin, then the WM8850 can be configured to behave in two ways:

Push Method

As soon as the S/PDIF Rx loses lock the stream is overwritten with zeros at the previously received sample rate. Once the S/PDIF Rx achieves lock again the zeros will be removed and the recovered samples will be output at the new sample rate. This is the default behaviour for the WM8850.

When configured for the push method it is still possible for the controller to terminate the stream while the S/PDIF Rx is unlocked by setting the Stream ID to 0. The stream will then not be restarted until the Stream ID has been assigned a new (non-zero) number and the S/PDIF Rx has achieved lock again.

Controlled Method

As soon as the S/PDIF Rx loses lock the stream is overwritten with zeros at the previous received sample rate. This will continue until the stream is terminated by the controller by setting the Stream ID to 0, even if the S/PDIF Rx regains lock. The stream will not be restarted until the Stream ID has been assigned a new (non-zero) number and the S/PDIF Rx has achieved lock again.

The controlled method protects against a change in the stream sample rate while the stream is active.

The S/PDIF receiver unlock behaviour is selected using the *S/PDIF In Control Verb*.

SET VERB	BIT	BITFIELD NAME	DEFAULT	DESCRIPTION
7A1h	3	Unlock Ctrl	0	S/PDIF In unlock control: 0 = Push method 1 = Controlled method

As the S/PDIF In node does not support presence detect as defined in the HDA specification, by default it will report *Presence Detect Capable=0* in the *Pin Capabilities Parameter*. However, it is possible to use the lock status of the S/PDIF Rx to indicate that something is plugged into S/PDIF In using the vendor-specific *S/PDIF In Control Verb*. If this feature is enabled the S/PDIF In node will report *Presence Detect Capable=1* in the *Pin Capabilities Parameter*, will support the *Pin Sense Verb* and be able to generate an unsolicited response based on the presence detect value in the *Pin Sense Verb* if this functionality is set in the *Unsolicited Response Verb*.

SET VERB	BIT	BITFIELD NAME	DEFAULT	DESCRIPTION
7A1h	2	PD Config	0	Configures the <i>Presence Detect Capable</i> parameter: 0 = Do not use lock status as presence detect 1 = Use lock status as presence detect

S/PDIF RX (NID = 05h)

Table 27 gives a summary of the S/PDIF Rx node:

NODE SUMMARY INFORMATION	
NID	05h
Widget Type	Audio Input
Supported Get Verbs	Ah, F00h, F02h, F03h, F06h, F08h, F0Dh, <i>F80h, F8Eh, F91h, F92h, F93h</i>
Supported Set Verbs	2h, 703h, 706h, 708h, 70Dh, <i>78Eh, 793h</i>
Unsolicited Responses	Stream Drop Sample Drop SRC1 Lock Status Change Digital Converter Register Update Validity Flag Status Change Channel Status Update Non-Audio Flag Status Change Data Receive Error
Vendor-Specific Verbs	F80h : S/PDIF Verb F8Eh, 78Eh : Unsolicited Response Priority Control Verb F91h : Get Channel Status Verb F92h : Get Non-Audio Flag Verb F93h, 793h : Sample Overwrite Control Verb

Table 27 S/PDIF Rx Node Summary Information

The S/PDIF Rx node provides control over the S/PDIF receiver circuitry and the optional SRC1 processing stage. The S/PDIF receiver measures the actual sample rate of the incoming S/PDIF signal, recovers the payload data and decodes channel status information. The recovered data can then be passed through SRC1 (Sample Rate Converter) if necessary to interface to the HDA link domain.

The *Digital Converter Verb* is supported by the S/PDIF Rx node, allowing readback of selected channel status information as defined in the HDA Specification. It is also possible to readback all 40-bits of the channel status data as defined in IEC-60958-3, using the vendor-specific *Get Channel Status Verb*.

GET VERB	BIT	BITFIELD NAME	DEFAULT	DESCRIPTION
F91h	39:36	Original Sampling Frequency	N/A	Original Sampling Frequency
	35:33	Sample Word Length	N/A	Sample Word Length
	32	Max Word Length	N/A	Max Word Length
	31:28	Clock Accuracy	N/A	Clock Accuracy
	27:24	Sampling Frequency	N/A	Sampling Frequency
	23:20	Channel Number	N/A	Channel Number
	19:16	Source Number	N/A	Source Number
	15:8	Category Code	N/A	Category Code
	7:6	Channel Status Mode	N/A	Channel Status Mode
	5:4	Additional De-emphasis Information	N/A	Additional De-emphasis Information
	3	PRE	N/A	Pre-emphasis
	2	/COPY	N/A	Copyright
	1	/AUDIO	N/A	Non Audio
	0	PRO	N/A	Professional/Consumer

Notes:

- [31:0] are returned when *Payload[7:0] = 00h*, [39:32] are returned when *Payload[7:0] = 01h*
- See IEC-60958-3 for full definitions of the channel status bits

The */AUDIO* flag in the channel status for the S/PDIF stream is set by the source of the S/PDIF data to indicate that the data samples within the S/PDIF stream are not audio PCM samples. In addition, IEC-61937 specifies a non-audio sync code which can be detected by the WM8850. The WM8850 provides a *Non Audio Flag* to indicate if the non-audio code has been detected. The *Non Audio Flag* can be readback using the vendor-specific *Get Non-Audio Flag Verb*.

GET VERB	BIT	BITFIELD NAME	DEFAULT	DESCRIPTION
F92h	0	Non Audio Flag	0	Indicates the presence of the <i>Non Audio Flag</i> . 0 = <i>Non Audio Flag</i> not asserted 1 = <i>Non Audio Flag</i> asserted

The generation of the *Non Audio Flag* is controllable in one of two ways:

- The non-audio code (as defined in IEC-61937) is received by the WM8850. The value of the /AUDIO channel status bit is ignored. The *Non Audio Flag* will clear after 4096 consecutive S/PDIF frames have been received without the non-audio code being present.
- The non-audio code (as defined in IEC-61937) is received by the WM8850 **and** the /AUDIO channel status bit is set to 1. The *Non Audio Flag* will clear after 4096 consecutive S/PDIF frames have been received without the non-audio code being present, or it will clear immediately if the /AUDIO channel status bit is cleared.

The required function of the *Non Audio Flag* is set by the NA_CNTRL field as part of the *Overwrite Control Verb*.

SET VERB	BIT	BITFIELD NAME	DEFAULT	DESCRIPTION
793h	2	NA_CNTRL	1	Controls the generation of the <i>Non-Audio Flag</i> : 0 = Asserted when the non-audio code (as defined in IEC-61937) is detected 1 = Asserted when the non-audio code (as defined in IEC-61937) is detected and the /AUDIO channel status bit is set

When the *Non Audio Flag* is asserted, the WM8850 can be configured to overwrite the recovered data samples with zeros using the vendor-specific *Overwrite Control Verb*.

SET VERB	BIT	BITFIELD NAME	DEFAULT	DESCRIPTION
793h	1	NA_OVWR_EN	0	Enables data overwrite when the <i>Non Audio Flag</i> is asserted: 0 = Do not overwrite 1 = Overwrite data with zeros

Notes:

1. When in Software Formatted S/PDIF Mode, only the 24-bit payload can be overwritten
2. When SRC1 is being used NA_OVWR_EN is set to 1 automatically by the WM8850 and becomes read-only

The WM8850 can detect a S/PDIF received data error. A received data error can be the result of a parity error, a bi-phase encoding error or by receiving out of sequence pre-amble. Using the vendor-specific *Overwrite Control Verb* it is possible to configure with WM8850 to automatically overwrite erroneous samples with zeros when a data error is detected and therefore the received sample is erroneous:

SET VERB	BIT	BITFIELD NAME	DEFAULT	DESCRIPTION
793h	0	DE_OVWR_EN	1	Enables data overwrite when a data error is detected: 0 = Do not overwrite erroneous sample 1 = Overwrite erroneous sample with zeros

Note: When in Software Formatted S/PDIF Mode, all 32-bits of the stream sample are overwritten

Note that the vendor-specific *S/PDIF Verb* supported by the S/PDIF Rx node is described in the "S/PDIF Receive using SRC1" section below.

S/PDIF RECEIVE USING SRC1

The WM8850 provides a full-range sample rate converter, SRC1, to interface between the S/PDIF receiver domain and the HDA link domain. SRC1 is implemented as a processing function within the S/PDIF Rx node, and so is enabled by the *Processing State Verb* as defined in the HDA Specification.

When SRC1 is enabled, it is configured automatically by the WM8850, using the recovered sample rate for the S/PDIF stream for the input sample rate, and the *Stream Format Verb* for the output sample rate. Figure 15 shows a simplified diagram to demonstrate this.

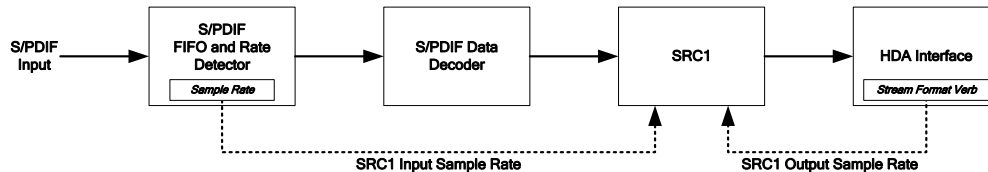

Figure 15 S/PDIF Receive using SRC1

When SRC1 is enabled, the lock status is reported using the vendor-specific *S/PDIF Verb* supported by the S/PDIF Rx node (NID = 05h).

GET VERB	BIT	BITFIELD NAME	DEFAULT	DESCRIPTION
F80h	8	SRC_LOCK	0	SRC1 lock flag: 0 = SRC1 unlocked 1 = SRC1 locked

When SRC1 is unlocked, it will output zero samples at the rate programmed by the *Stream Format Verb*. When SRC1 gains lock, transmission of valid samples will begin.

S/PDIF RECEIVE WITHOUT USING SRC1

When SRC1 is not enabled, the *Stream Format Verb* becomes read-only, and is set according to the recovered sample rate. Figure 16 shows a simplified diagram of this configuration.

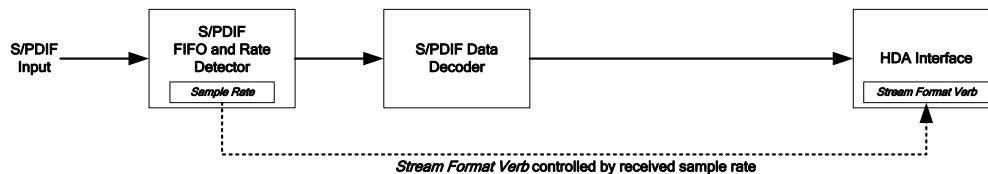

Figure 16 S/PDIF Receive without SRC1

S/PDIF RECEIVE TO DACS

It is possible to select S/PDIF Rx as the data source for the DACs on the WM8850, as described in the "Stereo Headphone Playback" and "Stereo Line Playback" sections.

In this mode, SRC1 is bypassed, the *Stream Format Verb* in each of the DAC nodes becomes read-only and are set according to the recovered sample rate. Figure 17 shows a simplified diagram of this configuration.

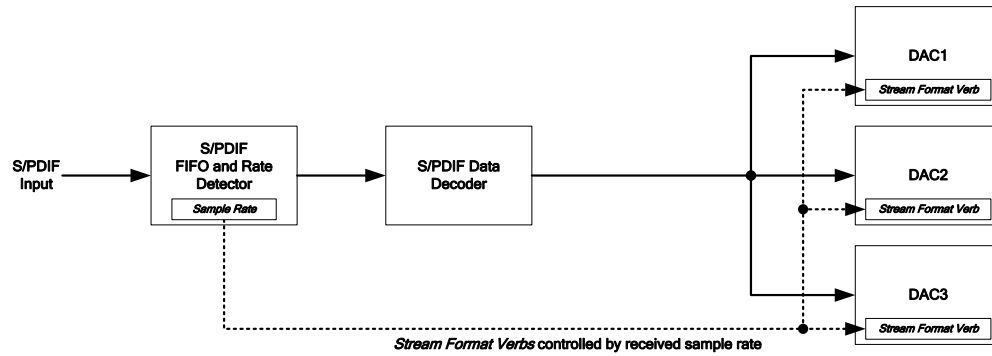

Figure 17 S/PDIF Receive to DACs

S/PDIF TRANSMIT

S/PDIF Transmit functionality is supported using the SPDIFOUT1 pin; this provides an IEC-60958-3 compatible S/PDIF output through the S/PDIF Tx 1 node. An on-chip, fully-asynchronous sample rate converter (SRC2) provides the flexibility to generate any supported outgoing S/PDIF rate from any supported HDA link rate if required.

S/PDIF Transmit functionality is also supported using the SPDIFOUT2 pin; this provides an IEC-60958-3 compatible S/PDIF output through the S/PDIF Tx 2 node. Note that there is no SRC associated with S/PDIF Tx 2.

It is possible to configure either of the S/PDIF outputs to select the ADC1, MIC1, MIC2 or S/PDIF In nodes as the data source. These signal paths are enabled using vendor-specific verbs, and are illustrated by dotted lines in Figure 18.

Both S/PDIF transmitters allow control over the channel status information.

Note that the SPDIFOUT2 pin also supports the DMICDAT2 function, which is described in the “Digital Microphone Record” section.

The WM8850 nodes associated with this function are shown in Figure 18.

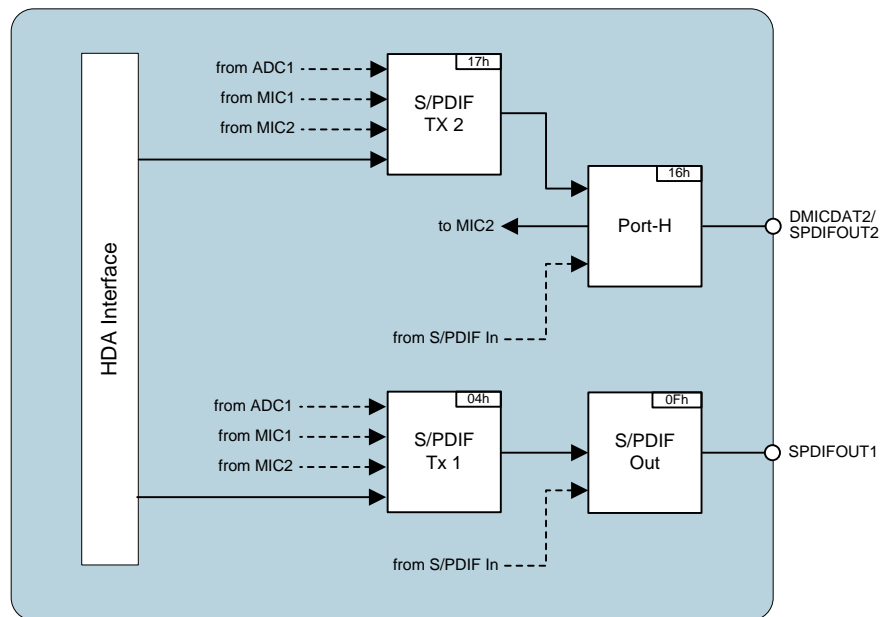

Figure 18 S/PDIF Transmit Paths

This section provides a summary of the S/PDIF Tx 1, S/PDIF Tx 2 and S/PDIF Out nodes, and describes the vendor-specific verb functions associated with each.

The Port-H node is described in the “Digital Microphone Record” section.

S/PDIF TX 1 (NID = 04h)

Table 26 gives a summary of the S/PDIF Tx 1 node:

NODE SUMMARY INFORMATION	
NID	04h
Widget Type	Audio Output
Supported Get Verbs	Ah, F00h, F03h, F06h, F08h, F0Dh, <i>F73h, F80h, F81h, F85h, F8Eh</i>
Supported Set Verbs	2h, 703h, 706h, 708h, 70Dh, 70Eh, <i>773h, 780h, 781h, 782h, 783h, 784h, 785h, 78Eh</i>
Unsolicited Responses	SRC2 Lock Status Stream Error
Vendor-Specific Verbs	F73h, 773h : Internal Path Verb F80h, 780h : S/PDIF Verb F81h, 781h, 782h, 783h, 784h : Tx Channel Status Control Verb F85h, 785h : Channel Status Data Packing Configuration Verb F8Eh, 78Eh : Unsolicited Response Priority Control Verb

Table 28 S/PDIF Tx 1 Node Summary Information

The S/PDIF Tx 1 node controls the formatting of the IEC-60958-3 compatible S/PDIF output stream and also the optional Sample Rate Conversion processing stage (SRC2).

Under default conditions, the S/PDIF Tx 1 node will process data received from the HDA interface. It is also possible to select ADC1, MIC1 or MIC2 as the data source, using the vendor-specific *Internal Path Verb*.

When ADC1, MIC1 or MIC2 is selected as the input to the S/PDIF Tx 1 node, the SRC2 is bypassed, the *Mult / Base / Div* fields in the *Stream Format Verb* become read-only and are set according to the selected source node.

SET VERB	BIT	BITFIELD NAME	DEFAULT	DESCRIPTION
773h	7:0	Path Sel	00h	Selects the source of the S/PDIF Tx 1 node: 00h = HDA Link 02h = ADC1 03h = MIC1 15h = MIC2

The *Digital Converter Verb* is supported by the S/PDIF Tx 1 node, allowing selected channel status information as defined in the HDA Specification to be set. It is also possible to set the remaining bits of channel status data as defined in IEC-60958-3, using the vendor-specific *Tx Channel Status Control Verb*.

SET VERB	BIT	BITFIELD NAME	DEFAULT	DESCRIPTION
784h	7:4	Channel Status [39:36]	0h	Original Sampling Frequency
	3:1	Channel Status [35:33]	5h	Sample Word Length
	0	Channel Status [32]	1	Max Word Length
783h	7:6	Channel Status [31:30]	0h	Channel Status [31:30]
	5:4	Channel Status [29:28]	0h	Clock Accuracy
	3:0	Channel Status [27:24]	1h	Sampling Frequency
782h	7:4	Channel Status [23:20]	0h	Channel Number for Sub-Frame B
	3:0	Channel Status [23:20]	0h	Channel Number for Sub-Frame A
781h	7:4	Channel Status [19:16]	0h	Source Number
	3:2	Channel Status [7:6]	0h	Channel Status Mode
	1:0	Channel Status [5:4]	0h	Additional De-emphasis information

Notes:

1. See IEC-60958-3 for full definitions of the channel status bits
2. The channel number of Sub-Frame B is uniquely configuration – all other channel status bits in Sub-Frame B have the same value as Sub-Frame A
3. Remaining channel status bits are set using the *Digital Converter Verb* as per the HDA Specification

Under default conditions, the WM8850 will pack the S/PDIF Tx Channel Status Data with the correct values of Sampling Frequency and Sample Word Length automatically, taking into account the various routing options through the chip. This means the Channel Status Data always reflects the same rate as the physical S/PDIF stream.

If required, this behaviour can be disabled using the vendor-specific *Channel Status Data Packing Configuration Verb*. When *CSD_MODE* is set to 0, the S/PDIF Tx Channel Status Data is completely defined using the vendor-specific *Tx Channel Status Control Verb*.

SET VERB	BIT	BITFIELD NAME	DEFAULT	DESCRIPTION
785h	0	CSD_MODE	1	S/PDIF Transmitter Channel Status Data Packing Mode: 0 = Manual mode: sample rate and data width channel status data packed from data sourced from the <i>Tx Channel Status Control Verb</i> 1 = Automatic mode: sample rate and data width channel status data packed from data sourced from the <i>Stream Verb</i> , <i>S/PDIF Verb</i> or S/PDIF Rx Rate Detector (depending on routing through device)

Note that the vendor-specific *S/PDIF Verb* supported by the S/PDIF Tx node is described in the “S/PDIF Transmit using SRC2” section below.

S/PDIF OUT (NID = 0Fh)

Table 30 gives a summary of the S/PDIF Out node:

NODE SUMMARY INFORMATION	
NID	0Fh
Widget Type	Pin Complex
Supported Get Verbs	F00h, F02h, F07h, F08h, F09h, F1Ch, <i>F73h, F8Eh</i>
Supported Set Verbs	707h, 708h, 71Ch, 71Dh, 71Eh, 71Fh, <i>773h, 78Eh</i>
Unsolicited Responses	Presence Detect
Vendor-Specific Verbs	F73h, 773h : Internal Path Verb F8Eh, 78Eh : Unsolicited Response Priority Control Verb

Table 29 S/PDIF Out Node Summary Information

The S/PDIF Out node controls the physical output to the SPDIFOUT1 pin.

Under default conditions, the S/PDIF Out node will output data from the S/PDIF Tx 1 node. It is also possible to select S/PDIF In as the data source, using the vendor-specific *Internal Path Verb*.

SET VERB	BIT	BITFIELD NAME	DEFAULT	DESCRIPTION
773h	7:0	Path Sel	04h	Selects the source of the S/PDIF Out node: 04h = S/PDIF Tx 1 10h = S/PDIF In All other values of Path Sel are reserved.

Note: This verb will override the path indicated by the *Get Connection List Entry Verb*.

S/PDIF TRANSMIT USING SRC2

The WM8850 provides a full-range sample rate converter, SRC2, to interface between the HDA link domain and the S/PDIF transmitter (S/PDIF Tx 1) domain. SRC2 is implemented as a processing function within the S/PDIF Tx 1 node, and so is enabled by the *Processing State Verb* as defined in the HDA Specification.

When SRC2 is enabled, it is configured automatically by the WM8850, using the *Stream Format Verb* for the input sample rate, and the vendor-specific *S/PDIF Verb* for the output. Figure 19 shows a simplified diagram to demonstrate this:

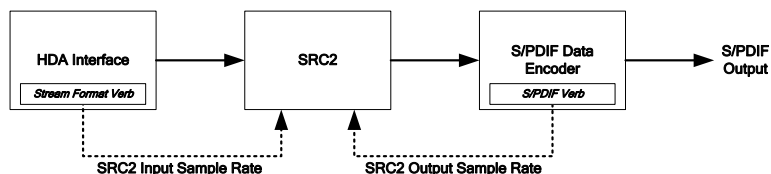

Figure 19 S/PDIF Transmit using SRC2

Note that the SRC2 Sample Rate Converter is associated with the S/PDIF Tx 1 node only; there is no SRC associated with S/PDIF Tx 2.

Note that, when SRC2 is enabled, the output S/PDIF stream will always contain 24-bit data.

The vendor-specific *S/PDIF Verb* implemented in the S/PDIF Tx 1 node is described below.

When SRC2 is enabled, the lock status is reported using the SRC_LOCK bit. When SRC2 is unlocked, it will output zero samples at the rate programmed by the *Stream Format Verb*. When SRC2 gains lock, transmission of valid samples will begin.

The *LINKED_MODE* bit provides the option to synchronise the S/PDIF Tx 1 output with the S/PDIF Rx input stream. Further details of this function are provided below.

GET VERB	BIT	BITFIELD NAME	DEFAULT	DESCRIPTION
F80h	8	SRC_LOCK	0	SRC2 lock flag: 0 = SRC2 unlocked 1 = SRC2 locked
	7	SRC_BASE	0	Used to set the base rate frequency: 0 = 48 kHz 1 = 44.1 kHz
	6:4	SRC_MULT	0h	Used to set the base rate multiplication factor: 0h = x1 (48 kHz, 44.1 kHz or less) 1h = x2 (96 kHz, 88.2 kHz, 32 kHz) 2h = Reserved 3h = x4 (192 kHz, 176.4 kHz) 4h-7h = Reserved
	3:1	SRC_DIV	0h	Used to set the base rate division factor: 0h = divide by 1 (48 kHz, 44.1 kHz) 1h = Reserved 2h = divide by 3 (32 kHz) 3h-7h = Reserved
	0	LINKED_MODE	0	Linked mode control: 0 = Linked mode disabled 1 = Linked mode enabled

When the *LINKED_MODE* bit is set in the *S/PDIF Verb*, the S/PDIF Tx 1 output is synchronised to the S/PDIF Rx input stream. In this mode, the *SRC_BASE* register field should be set to match the base rate frequency of the Input Sample Rate. The *SRC_MULT* and *SRC_DIV* fields can be used to select a range of S/PDIF Tx1 output sample rates which are synchronous to the received S/PDIF Rx sample rate. Figure 20 shows a simplified diagram:

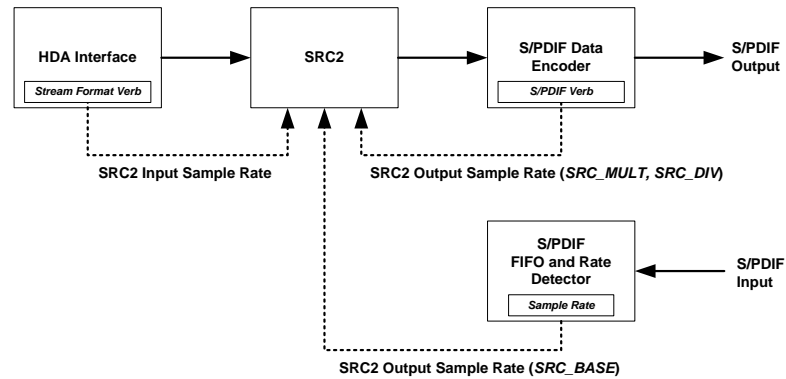

Figure 20 S/PDIF Transmit - Linked Mode

S/PDIF TRANSMIT WITHOUT USING SRC2

When SRC2 is not enabled, the output sample rate of the S/PDIF stream is controlled directly from *Stream Format Verb*. Figure 21 shows a simplified diagram:

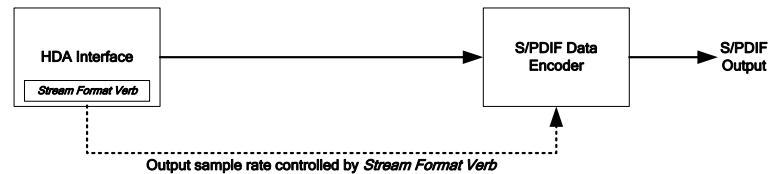

Figure 21 S/PDIF Transmit without SRC2

S/PDIF TX 2 (NID = 17h)

Table 30 gives a summary of the S/PDIF Tx 2 node:

NODE SUMMARY INFORMATION	
NID	17h
Widget Type	Audio Output
Supported Get Verbs	Ah, F00h, F06h, F08h, F0Dh, <i>F73h, F81h, F85h, F8Eh</i>
Supported Set Verbs	2h, 706h, 708h, 70Dh, 70Eh, <i>773h, 781h, 782h, 783h, 784h, 785h, 78Eh</i>
Unsolicited Responses	Stream Error
Vendor-Specific Verbs	F73h, 773h : Internal Path Verb F81h, 781h, 782h, 783h, 784h : Tx Channel Status Control Verb F85h, 785h : Channel Status Data Packing Configuration Verb F8Eh, 78Eh ; Unsolicited Response Priority Control Verb

Table 30 S/PDIF Tx 2 Node Summary Information

The S/PDIF Tx 2 node controls the formatting of the IEC-60958-3 compatible S/PDIF output stream.

Under default conditions, the S/PDIF Tx 2 node will process data received from the HDA interface. It is also possible to select ADC1, MIC1 or MIC2 as the data source, using the vendor-specific *Internal Path Verb*.

When ADC1, MIC1 or MIC2 is selected as the input to the S/PDIF Tx 2 node, the *Mult / Base / Div* fields in the *Stream Format Verb* become read-only and are set according to the selected source node.

SET VERB	BIT	BITFIELD NAME	DEFAULT	DESCRIPTION
773h	7:0	Path Sel	00h	Selects the source of the S/PDIF Tx 2 node: 00h = HDA Link 02h = ADC1 03h = MIC1 15h = MIC2

The *Digital Converter Verb* is supported by the S/PDIF Tx 2 node, allowing selected channel status information as defined in the HDA Specification to be set. It is also possible to set the remaining bits of channel status data as defined in IEC-60958-3, using the vendor-specific *Tx Channel Status Control Verb*.

SET VERB	BIT	BITFIELD NAME	DEFAULT	DESCRIPTION
784h	7:4	Channel Status [39:36]	0h	Original Sampling Frequency
	3:1	Channel Status [35:33]	5h	Sample Word Length
	0	Channel Status [32]	1	Max Word Length
783h	7:6	Channel Status [31:30]	0h	Channel Status [31:30]
	5:4	Channel Status [29:28]	0h	Clock Accuracy
	3:0	Channel Status [27:24]	1h	Sampling Frequency

782h	7:4	Channel Status [23:20]	0h	Channel Number for Sub-Frame B
	3:0	Channel Status [23:20]	0h	Channel Number for Sub-Frame A
781h	7:4	Channel Status [19:16]	0h	Source Number
	3:2	Channel Status [7:6]	0h	Channel Status Mode
	1:0	Channel Status [5:4]	0h	Additional De-emphasis information

Notes:

1. See IEC-60958-3 for full definitions of the channel status bits
2. The channel number ofr Sub-Frame B is uniquely configuration – all other channel status bits in Sub-Frame B have the same value as Sub-Frame A
3. Remaining channel status bits are set using the *Digital Converter Verb* as per the HDA Specification

Under default conditions, the WM8850 will pack the S/PDIF Tx Channel Status Data with the correct values of Sampling Frequency and Sample Word Length automatically, taking into account the various routing options through the chip. This means the Channel Status Data always reflects the same rate as the physical S/PDIF stream.

If required, this behaviour can be disabled using the vendor-specific *Channel Status Data Packing Configuration Verb*. When *CSD_MODE* is set to 0, the S/PDIF Tx Channel Status Data is completely defined using the vendor-specific *Tx Channel Status Control Verb*.

SET VERB	BIT	BITFIELD NAME	DEFAULT	DESCRIPTION
785h	0	CSD_MODE	1	S/PDIF Transmitter Channel Status Data Packing Mode: 0 = Manual mode: sample rate and data width channel status data packed from data sourced from the <i>Tx Channel Status Control Verb</i> 1 = Automatic mode: sample rate and data width channel status data packed from data sourced from the <i>Stream Verb</i> , <i>S/PDIF Verb</i> or S/PDIF Rx Rate Detector (depending on routing through device)

ANCILLARY FUNCTIONS

The WM8850 contains a beep widget suitable for the playback of system beeps to the analogue output widgets.

BEEP (NID = 14h)

Table 31 gives a summary of the Beep node:

NODE SUMMARY INFORMATION	
NID	14h
Widget Type	Beep Generator
Supported Get Verbs	Bh, F00h, F0Ah, F72h
Supported Set Verbs	3h, 70Ah, 772h
Unsolicited Responses	Not supported
Vendor-Specific Verbs	F72h, 772h : Beep Mask Selection Verb

Table 31 Beep Node Summary Information

The Beep node controls the system beep sound created by the WM8850. The volume of the beep signal is controlled using the *Amplifier Gain/Mute Verb*. The frequency of the beep signal is controlled using the *Beep Generation Verb*.

The beep signal overrides any sound currently being reproduced in the output path. Under default conditions, the beep is applied to all active outputs simultaneously. It is possible to mask the beep generator output to appear only at specific output nodes using the vendor-specific *Beep Mask Selection Verb*.

SET VERB	BIT	BITFIELD NAME	DEFAULT	DESCRIPTION
772h	2	Port-A Beep Mask	0h	Beep mask enable for Port-A (DAC1) 0h = Beep produced on Port-A 1h = Beep not produced on Port-A
	1	Port-G Beep Mask	0h	Beep mask enable for Port-G (DAC2) 0h = Beep produced on Port-G 1h = Beep not produced on Port-G
	0	Port-F Beep Mask	0h	Beep mask enable for Port-F (DAC3) 0h = Beep produced on Port-F 1h = Beep not produced on Port-F

AUDIO FUNCTION GROUP (NID = 01h)

Table 32 gives a summary of the Audio Function Group node:

NODE SUMMARY INFORMATION	
NID	01h
Widget Type	Audio Function Group
Supported Get Verbs	F00h, F05h, F08h, F15h, F16h, F17h, F18h, F19h, F1Ah, F20h, F71h, F86h, F8Eh
Supported Set Verbs	7FFh, 705h, 708h, 715h, 716h, 717h, 718h, 719h, 71Ah, 720h, 721h, 722h, 723h, 771h, 786h, 78Eh
Unsolicited Responses	GPIO status change
Vendor-Specific Verbs	F71h, 771h : VMID Control Verb F86h, 786h : GPIO Automatic Control Verb F8Eh, 78Eh : Unsolicited Response Priority Control Verb

Table 32 Audio Function Group Node Summary Information

VMID Voltage Reference Control

The analogue circuits in the WM8850 require a mid-rail analogue reference voltage, VMID. This reference is generated from AVDD via a programmable resistor chain. Together with the external VMID decoupling capacitor, the programmable resistor chain determines the charging rate on VMID. The resistor chain is selected using *VMID_SEL*, and can be used to optimise the reference for normal operation, low power standby or for fast start-up.

The VMID charge rate is controlled by *VMID_SEL* and the external VMID capacitor. The *VMID_RATE* field can be used to control the WM8850 power state according to the appropriate VMID conditions. In start-up from power state D4, the WM8850 will not indicate the D3 power state until the time set by *VMID_RATE* has elapsed.

The *VMID_SEL* and *VMID_RATE* fields are part of the *VMID Control Verb*.

SET VERB	BIT	BITFIELD NAME	DEFAULT	DESCRIPTION
771h	4:2	VMID_RATE	2h	Time allocated to charge VMID: 0h = 1024ms 1h = 512ms 2h = 256ms 3h = 128ms 4h = 64ms 5h = 32ms 6h = 16ms 7h = 8ms
	1:0	VMID_SEL	2h	VMID String Source Impedance Select: 0h = 12.5kΩ 1h = 75Ω 2h = 37.5kΩ 3h = 375kΩ Note: These figures give the value of the resistor from AVDD to VMID and from VMID to GND.

GPIO2 Automatic Control Mode

The *GPIO Automatic Control Verb* controls the behaviour of the GPIO2 pin.

In a system where external speaker amplifiers are connected to the WM8850 the GPIO2 pin may be used to control the enable pin(s) of these amplifiers. For this application, it is possible to automatically configure the GPIO2 pin as an output and to control its logic level as a function of the AFG power state. This function is enabled by setting *GPIO2_AUTO*=1 in the vendor-specific *GPIO Automatic Control Verb*:

SET VERB	BIT	BITFIELD NAME	DEFAULT	DESCRIPTION
786h	0	GPIO2_AUTO	1	GPIO2 Control Mode: 0 = GPIO2 Manual Mode 1 = GPIO Automatic Control Mode

The behaviour of GPIO2 when *GPIO2_AUTO*=1 is summarised in Table 33 below. When *GPIO2_AUTO*=0 the behaviour of GPIO2 is as per the standard GPIO verbs.

AFG PS-Act	GPIO2 Output
0	Logic 1
1	Logic 1
2	Logic 0
3	Logic 0
4	Logic 0

Table 33 GPIO2 Automatic Control Mode Summary
Unsolicited Response Priority Control Verb

The *Unsolicited Response Priority Control Verb* is supported by multiple nodes within the WM8850, including the Audio Function Group (AFG) node. This verb allows the Unsolicited Responses associated with each node to be prioritised relative to the other nodes.

The priority level for each node is set using the *Priority* field within the *Unsolicited Response Priority Control Verb*. When more than one Unsolicited Response is awaiting transmission, the node with the lowest *Priority* is placed at the front of the queue. Nodes that have the same *Priority* setting are queued on a 'first to trigger' basis.

Note that the lowest value of *Priority* represents the highest position in the queue.

The *Unsolicited Response Priority Control Verb* is defined as follows.

SET VERB	BIT	BITFIELD NAME	DEFAULT	DESCRIPTION
78Eh	4:0	Priority	00h	Assigns a priority setting for queued Unsolicited Responses. Nodes with the lowest value have the highest priority, and so go to the front of the Unsolicited Response queue. Nodes with the same value for priority are queued on first-to-trigger basis. 00h = Highest priority ... 1Fh = Lowest priority.

UNSOLICITED RESPONSES

The High Definition Audio Specification provides support for software interrupts to be generated by the CODEC independent of verb commands sent to the CODEC: these are known as Unsolicited Responses. This section defines how the WM8850 creates Unsolicited Responses, explains some of the novel features in the WM8850 to manage them, and what each Unsolicited Response from each node represents. This section assumes familiarity with the High Definition Audio Specification.

GENERATING UNSOLICITED RESPONSES

Unsolicited Responses can only be sent wherever a null response would normally be sent.

Unsolicited Responses are queued on a frame-basis. That is, if an Unsolicited Response is issued in the current frame, it is sent on the next frame containing a null response.

PRIORITY QUEUING

Where more than one Unsolicited Response is awaiting transmission, they are queued such that the Unsolicited Response with the lowest *Priority* value (set using the *Unsolicited Response Priority Control Verb*) is at the front of the queue. Nodes that have the same *Priority* setting are queued on a 'first-to-trigger' basis.

The *Unsolicited Response Priority Control Verb* is described in the "Ancillary Functions" section describing the Audio Function Group node.

IN-QUEUE-UPDATE

The WM8850 stores all flags that trigger an Unsolicited Response. If a node triggers an Unsolicited Response, the Unsolicited Response is queued as described above. Should the same node trigger a second Unsolicited Response (from a different flag within that node) while the first is being queued, the Unsolicited Response is updated to show both flags. This is known as an 'In-Queue-Update'. Should the same node trigger a second Unsolicited Response (from the same flag within the node) while the first is being queued, only one Unsolicited Response is sent for both events.

The concepts of Priority Queuing and In-Queue-Update are illustrated with the example in Figure 22.

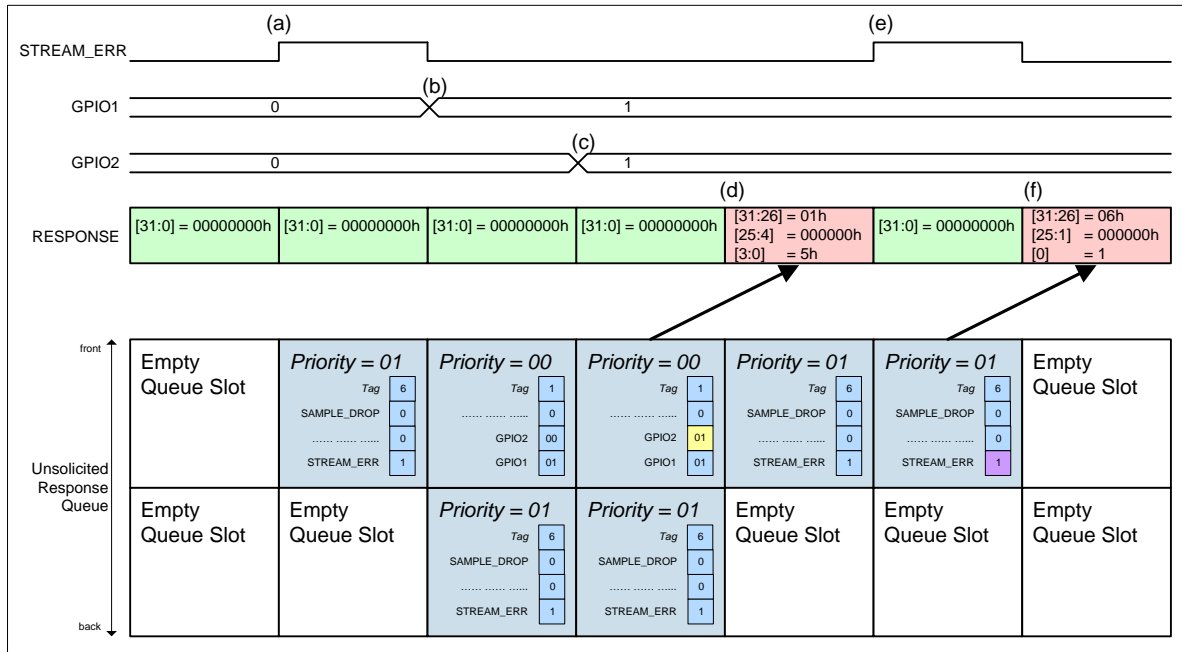

Figure 22 Priority Queuing and In-Queue Updates

- STREAM_ERR flag asserts from DAC1 Node (NID = 06h), and an Unsolicited Response (Tag ID = 06h) is queued awaiting a null response slot. STREAM_ERR rescinds at the end of the HDA frame.
- GPIO1 input changes to a 1 so the GPIO1 flag (from AFG NID = 01h) asserts and queues an Unsolicited Response (Tag ID = 01h). This Unsolicited Response goes to the front of the queue as its Priority value is lower (indicating higher priority) than the Priority setting of the Unsolicited Response presently at the front of the queue.
- GPIO2 input changes to a 1 so the GPIO2 flag asserts. The GPIO2_UPD flag is from the AFG (NID = 01h), and as there is already an Unsolicited Response from this node in the queue, the queued Unsolicited Response is updated to show both events (as highlighted with the yellow box). This is known as an 'In-Queue-Update'.
- A slot becomes available for sending an Unsolicited Response, so the AFG Unsolicited Response is transmitted as it is at the front of the queue.
- STREAM_ERR asserts from DAC1 Node (NID = 06h). As there is already an Unsolicited Response in the queue from this node, the Unsolicited Response is simply updated (as shown in the purple box). However, the queued Unsolicited Response already shows that there has been a STREAM_ERR flag so the In-Queue-Update does not actually change the Unsolicited Response value.
- A slot becomes available for sending an Unsolicited Response, so the Unsolicited Response (Tag ID = 06h) is transmitted.

UNSOLICITED RESPONSE TYPES

There are three types of flags that are returned by the WM8850, prefixed in the register map as follows:

SF = UNSOLICITED RESPONSE STATUS FLAG

Unsolicited Response Status Flags (SF) are used to indicate that there has been a change in flag state, and (where possible) convey what the new state is. A change in state is typically something that will persist for a number of HDA frames. A state change will trigger an Unsolicited Response, but it is possible that a state change can occur more than once while an Unsolicited Response is being queued.

To indicate this, Unsolicited Response Status Flags are 2-bits wide and are encoded as follows:

0h = Flag did not trigger Unsolicited Response.

1h = Rising edge of flag triggered Unsolicited Response.

2h = Falling edge of flag triggered Unsolicited Response.

3h = Rising and falling edges of the flag have been detected while the Unsolicited Response has been queued

When the Unsolicited Response Status Flag is reported as 0h, the user is informed that there has been no change in status. When the Unsolicited Response Status Flag is reported as 1h or 2h, the user is informed that there has been a change in status and what the new status value is. When the Unsolicited Response Status Flag is reported as 3h, the user is informed of a multiple change in status, and the user should read the associated flag's status register to get the current status value of the flag.

UF = UNSOLICITED RESPONSE UPDATE FLAG

Unsolicited Response Update Flags (UF) are used to indicate that there has been one or more changes to the value of some status registers. The status register should be read (through the issue of the appropriate Get command), to see the current register value.

EF = UNSOLICITED RESPONSE EVENT FLAG

Unsolicited Response Event Flags (EF) are used to indicate that an event has occurred during an HDA Frame. The occurrence of an event will trigger an Unsolicited Response.

UNSOLICITED RESPONSE DEFINITIONS

Table 34 gives a summary of the definitions of the Unsolicited Responses from each node in the WM8850. Note that these responses are generated only when the node is set to generate them, using the *Unsolicited Response Verb* as defined in the HDA specification.

NID	NODE NAME	UNSOLICITED RESPONSE		
		BIT	FLAG NAME	DESCRIPTION
01h	AFG	[31:26]	Tag	A software programmable tag value. The default value is equal to the Node ID. Other values can be configured using the Unsolicited Response Verb.
		[25:4]	Rsvd	Reserved
		[3:2]	SF_GPIO2	Indicates that the value on GPIO2 (configured as an input) has changed, and reports new status value. When the AFG is in power state D0, D1 or D2, a change in GPIO status triggers an Unsolicited Response. When the AFG is in power state D3, a change in GPIO status triggers a power state change request. Note that the status value is also accessible through the <i>Get GPIO Data Verb</i> .
		[1:0]	SF_GPIO1	Indicates that the value on GPIO1 (configured as an input) has changed, and reports new status value. When the AFG is in power state D0, D1 or D2, a change in GPIO status triggers an Unsolicited Response. When the AFG is in power state D3, a change in GPIO status triggers a power state change request. Note that the status value is also accessible through the <i>Get GPIO Data Verb</i> .
02h	ADC1	[31:26]	Tag	A software programmable tag value. The default value is equal to the Node ID. Other values can be configured using the Unsolicited Response Verb.
		[25:1]	Rsvd	Reserved
		[0]	EF_STREAM_DROP	Indicates that the stream associated with the ADC1 node has been dropped due to the bandwidth of the SDI line being oversubscribed. Assertion of the flag triggers an Unsolicited Response. The flag is cleared when the <i>Stream ID</i> is written to.
03h	MIC1	[31:26]	Tag	A software programmable tag value. The default value is equal to the Node ID. Other values can be configured using the Unsolicited Response Verb.
		[25:1]	Rsvd	Reserved
		[0]	EF_STREAM_DROP	Indicates that the stream associated with the MIC1 node has been dropped due to the bandwidth of the SDI line being oversubscribed. Assertion of the flag triggers an Unsolicited Response. The flag is cleared when the <i>Stream ID</i> is written to.

NID	NODE NAME	UNSOLICITED RESPONSE		
		BIT	FLAG NAME	DESCRIPTION
04h	S/PDIF TX 1	[31:26]	Tag	A software programmable tag value. The default value is equal to the Node ID. Other values can be configured using the Unsolicited Response Verb.
		[25:3]	Rsvd	Reserved
		[2]	EF_STREAM_ERR	Indicates that an error has occurred in the transfer of data from the HDA Link to the Stream Manager. Assertion of the flag triggers an Unsolicited Response. The flag rescinds at the end of the present HDA frame.
		[1:0]	SF_SRC2	Indicates that the lock status of SRC2 has changed, and reports the new lock status. A change in status triggers an Unsolicited Response. The status value is also accessible through the <i>Get SRC Verb</i> .
05h	S/PDIF Rx	[31:26]	Tag	A software programmable tag value. The default value is equal to the Node ID. Other values can be configured using the Unsolicited Response Verb.
		[25:11]	Rsvd	Reserved
		[10]	EF_STREAM_DROP	Indicates that the stream associated with the S/PDIF Rx node has been dropped due to the bandwidth of the SDI line being oversubscribed. Assertion of the flag triggers an Unsolicited Response. The flag is cleared when the <i>Stream ID</i> is written to.
		[9]	EF_SAMPLE_DROP	Indicates that additional samples (due to the recovered S/PDIF rate being faster than the nominal rate) have been dropped due to the bandwidth of the SDI line being oversubscribed. Assertion of the flag triggers an Unsolicited Response. The flag is cleared at the end of the present HDA frame.
		[8:7]	SF_SRC1	Indicates that the lock status of SRC1 has changed, and reports the new lock status. A change in status triggers an Unsolicited Response. The status value is also accessible through the <i>Get SRC Verb</i> .
		[6]	UF_CSUD_DC	Indicates that there has been a change to one of the bits in the <i>Digital Converter register</i> . A change in status triggers an Unsolicited Response. The status values are accessible through the <i>Get Digital Converter Verb</i> .
		[5:4]	SF_V_DC	Indicates that the validity bit has changed value. A change in status triggers an Unsolicited Response. The status value is also accessible through the <i>Get Digital Converter Verb</i> .

NID	NODE NAME	UNSOLICITED RESPONSE		
		BIT	FLAG NAME	DESCRIPTION
		[3]	UF_CSUD_CON	<p>Indicates that one (or more) of the first 40-bits of the channel status frame has changed.</p> <p>A change in status triggers an Unsolicited Response.</p> <p>The status values are accessible through the <i>Get Channel Status Verb</i>.</p>
		[2:1]	SF_NAF	<p>Indicates that the non-audio flag (defined in IEC-61937) has changed value.</p> <p>A change in status triggers an Unsolicited Response.</p> <p>The status value is also accessible through the <i>Get Non-Audio Flag Verb</i>.</p>
		[0]	EF_DATA_ERR	<p>Indicates there has been a parity error, bi-phase encoding error or that preambles have been recovered out of sequence in the received S/PDIF stream.</p> <p>Assertion of the flag triggers an Unsolicited Response.</p> <p>The flag is cleared at the end of the present HDA frame.</p>
06h	DAC1	[31:26]	Tag	<p>A software programmable tag value. The default value is equal to the Node ID. Other values can be configured using the Unsolicited Response Verb.</p>
		[25:1]	Rsvd	Reserved
		[0]	EF_STREAM_ERR	<p>Indicates that an error has occurred in the transfer of data from the HDA Link to the Stream Manager.</p> <p>Assertion of the flag triggers an Unsolicited Response.</p> <p>The flag is cleared at the end of the present HDA frame.</p>
07h	DAC2	[31:26]	Tag	<p>A software programmable tag value. The default value is equal to the Node ID. Other values can be configured using the Unsolicited Response Verb.</p>
		[25:1]	Rsvd	Reserved
		[0]	EF_STREAM_ERR	<p>Indicates that an error has occurred in the transfer of data from the HDA Link to the Stream Manager.</p> <p>Assertion of the flag triggers an Unsolicited Response.</p> <p>The flag is cleared at the end of the present HDA frame.</p>
08h	DAC3	[31:26]	Tag	<p>A software programmable tag value. The default value is equal to the Node ID. Other values can be configured using the Unsolicited Response Verb.</p>
		[25:1]	Rsvd	Reserved
		[0]	EF_STREAM_ERR	<p>Indicates that an error has occurred in the transfer of data from the HDA Link to the Stream Manager.</p> <p>Assertion of the flag triggers an Unsolicited Response.</p> <p>The flag is cleared at the end of the present HDA frame.</p>

NID	NODE NAME	UNSOLICITED RESPONSE		
		BIT	FLAG NAME	DESCRIPTION
0Ch	Port-E	[31:26]	Tag	A software programmable tag value. The default value is equal to the Node ID. Other values can be configured using the Unsolicited Response Verb.
		[25:2]	Rsvd	Reserved
		[1:0]	SF_PD	Indicates that the Presence Detect value (in the <i>Pin Sense Verb</i>) has changed. A change in status triggers an Unsolicited Response (when the AFG is in power state D0, D1, D2) or it triggers a power state change request (when the AFG is in power state D3). The status value is also accessible through the <i>Get Pin Sense Verb</i> .
0Dh	Port-B	[31:26]	Tag	A software programmable tag value. The default value is equal to the Node ID. Other values can be configured using the Unsolicited Response Verb.
		[25:3]	Rsvd	Reserved
		[2]	EF_IMP	Indicates that the Impedance Sense value is ready. Assertion of the flag triggers an Unsolicited Response. The flag is cleared on an issue of a <i>Get Pin Sense Verb</i> .
		[1:0]	SF_PD	Indicates that the Presence Detect value (in the <i>Pin Sense Verb</i>) has changed. A change in status triggers an Unsolicited Response (when the AFG is in power state D0, D1, D2) or it triggers a power state change request (when the AFG is in power state D3). The status value is also accessible through the <i>Get Pin Sense Verb</i> .
0Fh	S/PDIF Out	[31:26]	Tag	A software programmable tag value. The default value is equal to the Node ID. Other values can be configured using the Unsolicited Response Verb.
		[25:2]	Rsvd	Reserved
		[1:0]	SF_PD	Indicates that the Presence Detect value (in the <i>Pin Sense Verb</i>) has changed. A change in status triggers an Unsolicited Response (when the AFG is in power state D0, D1, D2) or it triggers a power state change request (when the AFG is in power state D3). The status value is also accessible through the <i>Get Pin Sense Verb</i> .

NID	NODE NAME	UNSOLICITED RESPONSE		
		BIT	FLAG NAME	DESCRIPTION
10h	S/PDIF In	[31:26]	Tag	A software programmable tag value. The default value is equal to the Node ID. Other values can be configured using the Unsolicited Response Verb.
		[25:5]	Rsvd	Reserved
		[4]	UF_RATE	Indicates that the recovered sample rate of the S/PDIF receiver has changed. A change in status triggers an Unsolicited Response. The status value is accessible through the <i>Get S/PDIF In Status Verb</i> .
		[3:2]	SF_SPDIN	Indicates that the Lock status of the in the S/PDIF Receiver. A change in status triggers an Unsolicited Response. The status value is also accessible through the <i>Get S/PDIF In Status Verb</i> .
		[1:0]	SF_PD	Indicates that the Presence Detect value (in the <i>Pin Sense Verb</i>) has changed. A change in status triggers an Unsolicited Response (when the AFG is in power state D0, D1, D2) or it triggers a power state change request (when the AFG is in power state D3). The status value is also accessible through the <i>Get Pin Sense Verb</i> .
11h	Port-A	[31:26]	Tag	A software programmable tag value. The default value is equal to the Node ID. Other values can be configured using the Unsolicited Response Verb.
		[25:2]	Rsvd	Reserved
		[1:0]	SF_PD	Indicates that the Presence Detect value (in the <i>Pin Sense Verb</i>) has changed. A change in status triggers an Unsolicited Response (when the AFG is in power state D0, D1, D2) or it triggers a power state change request (when the AFG is in power state D3). The status value is also accessible through the <i>Get Pin Sense Verb</i> .
12h	Port-G	[31:26]	Tag	A software programmable tag value. The default value is equal to the Node ID. Other values can be configured using the Unsolicited Response Verb.
		[25:2]	Rsvd	Reserved
		[1:0]	SF_PD	Indicates that the Presence Detect value (in the <i>Pin Sense Verb</i>) has changed. A change in status triggers an Unsolicited Response (when the AFG is in power state D0, D1, D2) or it triggers a power state change request (when the AFG is in power state D3). The status value is also accessible through the <i>Get Pin Sense Verb</i> .

NID	NODE NAME	UNSOLICITED RESPONSE		
		BIT	FLAG NAME	DESCRIPTION
13h	Port-F	[31:26]	Tag	A software programmable tag value. The default value is equal to the Node ID. Other values can be configured using the Unsolicited Response Verb.
		[25:2]	Rsvd	Reserved
		[1:0]	SF_PD	Indicates that the Presence Detect value (in the <i>Pin Sense Verb</i>) has changed. A change in status triggers an Unsolicited Response (when the AFG is in power state D0, D1, D2) or it triggers a power state change request (when the AFG is in power state D3). The status value is also accessible through the <i>Get Pin Sense Verb</i> .
15h	MIC2	[31:26]	Tag	A software programmable tag value. The default value is equal to the Node ID. Other values can be configured using the Unsolicited Response Verb.
		[25:1]	Rsvd	Reserved
		[0]	EF_STREAM_DROP	Indicates that the stream associated with the MIC2 node has been dropped due to the bandwidth of the SDI line being oversubscribed. Assertion of the flag triggers an Unsolicited Response. The flag is cleared when the <i>Stream ID</i> is written to.
17h	S/PDIF Tx 2	[31:26]	Tag	A software programmable tag value. The default value is equal to the Node ID. Other values can be configured using the Unsolicited Response Verb.
		[25:1]	Rsvd	Reserved
		[0]	EF_STREAM_ERR	Indicates that an error has occurred in the transfer of data from the HDA Link to the Stream Manager. Assertion of the flag triggers an Unsolicited Response. The flag is cleared at the end of the present HDA frame.

Table 34 Unsolicited Response Summary

DETAILED VERB DESCRIPTIONS

This section provides full verb information on each node in the WM8850. For verbs defined as part of the High Definition Audio Specification Revision 1.0 this is the only information provided. For vendor-specific verbs, more detailed explanation of the function is provided in the main text of the datasheet above.

ROOT NODE (NID = 00H)

	Verb ID	Payload [7:0]	Response[31:0]
Get	F00h	Parameter ID (PID)	Parameter Value

Vendor ID Response Format (PID = 00h)

Bit	Bitfield Name	RW	Default	Description
[31:16]	Vendor ID	R	1AECh	Vendor ID
[15:0]	Device ID	R	8800h	Device ID = WM8800

Revision ID Response Format (PID = 02h)

Bit	Bitfield Name	RW	Default	Description
[31:24]	Rsvd	R	00h	Reserved
[23:20]	MajRev	R	1h	Major revision number (left of the decimal) of the HDA Specification to which the WM8850 is fully compliant
[19:16]	MinRev	R	0h	Minor revision number (right of the decimal) of the HDA Specification to which the WM8850 is fully compliant
[15:8]	Revision ID	R	-	Cirrus Logic revision ID number for this device
[7:0]	Stepping ID	R	-	Optional stepping number within the Revision ID

Subordinate Node Count Response Format (PID = 04h)

Bit	Bitfield Name	RW	Default	Description
[31:24]	Rsvd	R	00h	Reserved
[23:16]	Starting NID	R	01h	Starting NID of the first function group
[15:8]	Rsvd	R	00h	Reserved
[7:0]	Total Nodes	R	1h	Total number of function group nodes

AUDIO FUNCTION GROUP (NID = 01H)
FUNCTION RESET VERB

	Verb ID	Payload [7:0]	Response[31:0]
Execute	7FFh	00h	00000000h

Bit	Bitfield Name	RW	Default	Description
[7:0]	Reset	W	00h	AFG reset. 00h = AFG and all widget nodes associated with the AFG will reset to default values. The WM8850 will issue a response and then be ready to accept commands in the frame following the valid response. Note: The <i>Implementation ID/Subsystem ID Verb</i> and the <i>Configuration Default Verb</i> will not be reset using this verb.

GET PARAMETER VERB

	Verb ID	Payload [7:0]	Response[31:0]
Get	F00h	Parameter ID (PID)	Parameter Value

Subordinate Node Count Response Format (PID = 04h)

Bit	Bitfield Name	RW	Default	Description
[31:24]	Rsvd	R	00h	Reserved
[23:16]	Starting NID	R	02h	Starting NID of the first widget in the AFG
[15:8]	Rsvd	R	00h	Reserved
[7:0]	Total Nodes	R	16h	Total number of widget nodes within the AFG

Function Group Type Response Format (PID = 05h)

Bit	Bitfield Name	RW	Default	Description
[31:9]	Rsvd	R	000000h	Reserved
[8]	Unsol	R	1	The AFG Node is capable of generating Unsolicited Responses
[7:0]	Node Type	R	01h	Node Type is Audio Function Group

Audio Function Group Capabilities Response Format (PID = 08h)

Bit	Bitfield Name	RW	Default	Description
[31:17]	Rsvd	R	0000h	Reserved
[16]	Beep Gen	R	1	Beep Generator Widget present
[15:12]	Rsvd	R	00h	Reserved
[11:8]	Input Delay	R	8h	Number of samples of input delay
[7:4]	Rsvd	R	00h	Reserved
[3:0]	Output Delay	R	8h	Number of samples of output delay

Input Amplifier Capabilities Response Format (PID = 0Dh)

Bit	Bitfield Name	RW	Default	Description
[31]	Mute Capable	R	0	Microphone preamplifiers are not capable of muting
[30:23]	Rsvd	R	00h	Reserved
[22:16]	Step Size	R	27h	Gain step size is 10dB
[15]	Rsvd	R	0	Reserved
[14:8]	Num Steps	R	03h	Number of steps in gain range is 4 (0dB to +30dB)
[7]	Rsvd	R	0	Reserved
[6:0]	Offset	R	0h	The step number that 0dB corresponds to is 0

Output Amplifier Capabilities Response Format (PID = 12h)

Bit	Bitfield Name	RW	Default	Description
[31]	Mute Capable	R	1	DAC Volume control is capable of muting
[30:23]	Rsvd	R	0000h	Reserved
[22:16]	Step Size	R	01h	Gain step size is 0.5dB
[15]	Rsvd	R	0	Reserved
[14:8]	Num Steps	R	7Fh	Number of steps in gain range is 128 (0dB to -63.5dB)
[7]	Rsvd	R	0	Reserved
[6:0]	Offset	R	7Fh	The step number that 0dB corresponds to is 7Fh

Supported Power States Response Format (PID = 0Fh)

Bit	Bitfield Name	RW	Default	Description
[31]	EPSS	R	0	EPSS not supported
[30]	CLKSTOP	R	1	Indicates that the link BCLK can be stopped when the WM8850 is in power state D3. The WM8850 will still perform jack detection and issue a wake the Presence Detect value of a node (in its <i>Pin Sense Verb</i>) has changed. Note: The <i>Power State Verb</i> for the AFG should be queried before actually stopping BCLK to ensure it is acceptable to do so
[29:5]	Rsvd	R	0000000h	Reserved
[4]	D4Sup	R	1	D4 Power State supported
[3]	D3Sup	R	1	D3 Power State supported
[2]	D2Sup	R	1	D2 Power State supported
[1]	D1sup	R	1	D1 Power State supported
[0]	D0Sup	R	1	D0 Power State supported

GPIO Count Response Format (PID = 11h)

Bit	Bitfield Name	RW	Default	Description
[31]	GPIO Wake	R	1	Indicates that a GPIO configured as an input can cause a wake (i.e. generate a Status Change event on the HDA Link)
[30]	GPIO Unsol	R	1	Indicates that a GPIO configured as an input can cause an Unsolicited Response to be generated
[29:24]	Rsvd	R	00h	Reserved
[23:16]	Num GPIs	R	00h	Device does not support any GPI pins
[15:8]	Num GPOs	R	00h	Device does not support any GPO pins
[7:0]	Num GPIOs	R	02h	Device supports 2 GPIO pins

POWER STATE VERB

	Verb ID	Payload [7:0]	Response[31:0]
Get	F05h	00h	Bits [31:0] in the table below
Set	705h	Bits [7:0] in the table below	00000000h

Bit	Bitfield Name	RW	Default	Description
[31:10]	Rsvd	R	000000h	Reserved
[9]	PS-ClkStopOK	R	0	Applicable when the AFG is in power state D3: 0 = BCLK must be kept running 1 = It is OK to stop BCLK
[8]	Rsvd	R	0	Reserved
[7:4]	PS-Act	R	2h	Indicates the actual power state of the AFG node: 0h = D0 1h = D1 2h = D2 3h = D3 4h = D4 The power state of the AFG is controlled by <i>PS-Set</i> below. For the AFG, <i>PS-Act</i> will equal <i>PS-Set</i> (offset by the time required to execute a power state transition).
[3:0]	PS-Set	RW	2h	Sets the power state of the AFG node: 0h = D0 1h = D1 2h = D2 3h = D3 4h = D4

Note: If the Link is operational, but the AFG is in power state D4, only Get Commands, Set Power State or AFG Reset commands are executed – all other commands are ignored. In this scenario, the SDI line is inactive and does not transmit responses, tags or data.

UNSOLICITED RESPONSE VERB

	Verb ID	Payload [7:0]	Response[31:0]
Get	F08h	00h	Bits [31:0] in the table below
Set	708h	Bits [7:0] in the table below	00000000h

Bit	Bitfield Name	RW	Default	Description
[31:8]	Rsvd	R	000000h	Reserved
[7]	Enable	RW	0	0 = Unsolicited Responses disabled for this node 1 = Unsolicited Responses enabled for this node
[6]	Rsvd	R	0	Reserved
[5:0]	Tag	RW	01h	A software programmable tag value that is returned in the top six bits (31:26) of every Unsolicited Response from this node. The default for <i>Tag</i> is equal to the Node ID.

Note: The Unsolicited Response for the AFG node is defined in the “Unsolicited Responses” section.

GPIO DATA VERB

	Verb ID	Payload [7:0]	Response[31:0]
Get	F15h	00h	Bits [31:0] in the table below
Set	715h	Bits [7:0] in the table below	00000000h

Bit	Bitfield Name	RW	Default	Description
[31:2]	Rsvd	R	00000000h	Reserved
[1]	Data[1]	RW	0	Sets and returns data associated with the GPIO2 pin
[0]	Data[0]	RW	0	Sets and returns data associated with the GPIO1 pin

GPIO ENABLE MASK VERB

	Verb ID	Payload [7:0]	Response[31:0]
Get	F16h	00h	Bits [31:0] in the table below
Set	716h	Bits [7:0] in the table below	00000000h

Bit	Bitfield Name	RW	Default	Description
[31:2]	Rsvd	R	00000000h	Reserved
[1]	Enable[1]	RW	0	0 = GPIO2 pin disabled (Hi-Z) 1 = GPIO2 pin enabled
[0]	Enable[0]	RW	0	0 = GPIO1 pin disabled (Hi-Z) 1 = GPIO1 pin enabled

GPIO DIRECTION VERB

	Verb ID	Payload [7:0]	Response[31:0]
Get	F17h	00h	Bits [31:0] in the table below
Set	717h	Bits [7:0] in the table below	00000000h

Bit	Bitfield Name	RW	Default	Description
[31:2]	Rsvd	R	00000000h	Reserved
[1]	Control[1]	RW	0	0 = GPIO2 pin is an input 1 = GPIO2 pin is an output
[0]	Control[0]	RW	0	0 = GPIO1 pin is an input 1 = GPIO1 pin is an output

GPIO WAKE ENABLE MASK VERB

	Verb ID	Payload [7:0]	Response[31:0]
Get	F18h	00h	Bits [31:0] in the table below
Set	718h	Bits [7:0] in the table below	00000000h

Bit	Bitfield Name	RW	Default	Description
[31:2]	Rsvd	R	00000000h	Reserved
[1]	Wake[1]	RW	0	0 = GPIO2 wake disabled 1 = GPIO2 wake enabled Note: Applies only if GPIO2 is configured as an input
[0]	Wake[0]	RW	0	0 = GPIO1 wake disabled 1 = GPIO1 wake enabled Note: Applies only if GPIO1 is configured as an input

GPIO UNSOLICITED ENABLE MASK VERB

	Verb ID	Payload [7:0]	Response[31:0]
Get	F19h	00h	Bits [31:0] in the table below
Set	719h	Bits [7:0] in the table below	00000000h

Bit	Bitfield Name	RW	Default	Description
[31:2]	Rsvd	R	00000000h	Reserved
[1]	UnsolEnable[1]	RW	0	0 = GPIO2 cannot generate an Unsolicited Response 1 = GPIO2 can generate an Unsolicited Response Note: Applies only if GPIO2 is configured as an input
[0]	UnsolEnable[0]	RW	0	0 = GPIO1 cannot generate an Unsolicited Response 1 = GPIO1 can generate an Unsolicited Response Note: Applies only if GPIO1 is configured as an input

GPIO STICKY MASK VERB

	Verb ID	Payload [7:0]	Response[31:0]
Get	F1Ah	00h	Bits [31:0] in the table below
Set	71Ah	Bits [7:0] in the table below	00000000h

Bit	Bitfield Name	RW	Default	Description
[31:2]	Rsvd	R	00000000h	Reserved
[1]	Data[1]	RW	0	0 = GPIO2 is non-sticky (level sensitive) 1 = GPIO2 is sticky (edge-sensitive) Note: Applies only if GPIO2 is configured as an input
[0]	Data[0]	RW	0	0 = GPIO1 is non-sticky (level sensitive) 1 = GPIO1 is sticky (edge-sensitive) Note: Applies only if GPIO1 is configured as an input

IMPLEMENTATION ID / SUBSYSTEM ID VERB

	Verb ID	Payload [7:0]	Response[31:0]
Get	F20h	00h	Bits [31:0] in the table below
Set1	720h	Implementation ID[7:0]	00h
Set2	721h	Implementation ID[15:8]	00h
Set3	722h	Implementation ID[23:16]	00h
Set4	723h	Implementation ID[31:24]	00h

Bit	Bitfield Name	RW	Default	Description
[31:0]	Implementation ID	RW	00000100h	Implementation ID

Note: The *Implementation ID / Subsystem ID Verb* is not reset to its default value during a reset from any source. The settings are only lost when digital power is removed from the WM8850. When digital power is restored, the System BIOS must restore the settings.

VMID CONTROL VERB (VENDOR SPECIFIC)

	Verb ID	Payload [7:0]	Response[31:0]
Get	F71h	00h	Bits [31:0] in the table below
Set	771h	Bits [7:0] in the table below	00000000h

Bit	Bitfield Name	RW	Default	Description
[31:6]	Rsvd	R	0000000h	Reserved
[4:2]	VMID_RATE	RW	2h	Time allocated to charge VMID: 0h = 1024ms 1h = 512ms 2h = 256ms 3h = 128ms 4h = 64ms 5h = 32ms 6h = 16ms 7h = 8ms
[1:0]	VMID_SEL	RW	2h	VMID String Source Impedance Select: 0h = 12.5kΩ 1h = 75kΩ 2h = 37.5kΩ 3h = 375kΩ Note: These figures give the value of the resistor from AVDD to VMID and from VMID to GND.

GPIO AUTOMATIC CONTROL VERB (VENDOR-SPECIFIC)

	Verb ID	Payload [7:0]	Response[31:0]
Get	F86h	00h	Bits [31:0] in the table below
Set	786h	Bits [7:0] in the table below	00000000h

Bit	Bitfield Name	RW	Default	Description
[31:1]	Rsvd	R	0000000h	Reserved
[0]	GPIO2_AUTO	RW	1	GPIO2 Control Mode: 0 = GPIO2 Manual Mode GPIO2 is controlled manually via the standard AFG verbs 1 = GPIO Automatic Control Mode GPIO2 is always an output and forced high when PS-Act of AFG is D1 or D0. GPIO2 is forced low when PS-Act of AFG is D2, D3 or D4.

UNSOLICITED RESPONSE PRIORITY CONTROL VERB (VENDOR-SPECIFIC)

	Verb ID	Payload [7:0]	Response[31:0]
Get	F8Eh	00h	Bits [31:0] in the table below
Set	78Eh	Bits [7:0] in the table below	00000000h

Bit	Bitfield Name	RW	Default	Description
[31:5]	Rsvd	R	0000000h	Reserved
[4:0]	Priority	RW	00h	Assigns a priority setting for queued Unsolicited Responses. Nodes with the lowest value have the highest priority, and so go to the front of the Unsolicited Response queue. Nodes with the same value for priority are queued on first-to-trigger basis. 00h = Highest priority ... 1Fh = Lowest priority.

00h
01h
02h
03h
04h
05h
06h
07h
08h
09h
0Ah
0Bh
0Ch
0Dh
0Eh
0Fh
10h
11h
12h
13h
14h
15h
16h
17h

ADC1 AUDIO INPUT CONVERTER WIDGET (NID = 02H)
STREAM FORMAT VERB

	Verb ID	Payload [15:0]	Response[31:0]
Get	Ah	0000h	Bits [31:0] in the table below
Set	2h	Bits [15:0] in the table below	00000000h

Bit	Bitfield Name	RW	Default	Description
[31:16]	Rsvd	R	0000h	Reserved
[15]	Type	R	0	Indicates the widget supports only PCM streams
[14]	Base	RW	0	Used to set the base rate frequency: 0 = 48 kHz 1 = 44.1 kHz
[13:11]	Mult	RW	0h	Used to set the base rate multiplication factor: 0h = x1 (48kHz, 44.1kHz or less) 1h = x2 (96kHz, 88.2kHz, 32kHz) 2h-7h = Reserved
[10:8]	Div	RW	0h	Used to set the base rate division factor: 0h = divide by 1 (48kHz, 44.1kHz) 1h = divide by 2 (22.05kHz) 2h = divide by 3 (16kHz, 32kHz) 3h = divide by 4 (11.025kHz) 4h = Reserved 5h = divide by 6 (8kHz) 6h = Reserved 7h = Reserved
[7]	Rsvd	R	0	Reserved
[6:4]	Bits	RW	3h	Bits per Sample: 0h = Reserved 1h = 16 bits 2h = 20 bits 3h = 24 bits 4h = 32 bits (Float 32) 5h-7h = Reserved
[3:0]	Chan	RW	1h	Number of Channels in each frame of the stream: 0h = 1 channel 1h = 2 channels 2h-Fh = reserved

GET PARAMETER VERB

	Verb ID	Payload [7:0]	Response[31:0]
Get	F00h	Parameter ID (PID)	Parameter Value

Audio Widget Capabilities Parameter (PID = 09h)

Bit	Bitfield Name	RW	Default	Description
[31:24]	Rsvd	R	00h	Reserved
[23:20]	Type	R	1h	Indicates that this is an Audio Input Widget
[19:16]	Delay	R	0h	Latency not reported
[15:12]	Rsvd	R	0h	Reserved
[11]	L-R Swap	R	0	Left/Right swap capability not supported
[10]	PowerCntrl	R	1	Indicates that the <i>Power State Verb</i> is supported in this widget
[9]	Digital	R	0	Indicates that this widget is translating analogue data
[8]	Conn List	R	1	Indicates that a connection list is present
[7]	Unsol Capable	R	1	Widget supports Unsolicited Responses
[6]	ProcWidget	R	1	Widget has processing capabilities (i.e high pass filter)
[5]	Stripe	R	0	Widget does not support striping
[4]	Format Override	R	1	Widget has a subset of the supported rates defined for the AFG
[3]	Amp Parameter Override	R	0	Not applicable as this widget does not have amplifier capabilities
[2]	Out Amp Present	R	0	Output amplifier not present in this widget
[1]	In Amp Present	R	0	Input amplifier not present in this widget
[0]	Stereo	R	1	Indicates that this is a stereo widget

Supported Rates Parameter (PID = 0Ah)

Bit	Bitfield Name	RW	Default	Description
[31:21]	Rsvd	R	000h	Reserved
[20]	B32	R	1	ADC1 supports 32-bit audio format
[19]	B24	R	1	ADC1 supports 24-bit audio format
[18]	B20	R	1	ADC1 supports 20-bit audio format
[17]	B16	R	1	ADC1 supports 16-bit audio format
[16]	B8	R	0	ADC1 does not support 8-bit audio format
[15:12]	Rsvd	R	0h	Reserved
[11]	R12	R	0	ADC1 does not support 384 kHz sample rate
[10]	R11	R	0	ADC1 does not support 192 kHz sample rate
[9]	R10	R	0	ADC1 does not support 176.4 kHz sample rate
[8]	R9	R	1	ADC1 supports 96 kHz sample rate
[7]	R8	R	1	ADC1 supports 88.2 kHz sample rate
[6]	R7	R	1	ADC1 supports 48 kHz sample rate
[5]	R6	R	1	ADC1 supports 44.1 kHz sample rate
[4]	R5	R	1	ADC1 supports 32 kHz sample rate
[3]	R4	R	1	ADC1 supports 22.05 kHz sample rate
[2]	R3	R	1	ADC1 supports 16 kHz sample rate
[1]	R2	R	1	ADC1 supports 11.025 kHz sample rate
[0]	R1	R	1	ADC1 supports 8 kHz sample rate

Supported Stream Formats Parameter (PID = 0Bh)

Bit	Bitfield Name	RW	Default	Description
[31:3]	Rsvd	R	00000000h	Reserved
[2]	AC3	R	0	ADC1 does not support Dolby AC3 formatted data
[1]	Float32	R	1	ADC1 supports Float32 formatted data
[0]	PCM	R	1	ADC1 supports PCM formatted data

Connection List Length Parameter (PID = 0Eh)

Bit	Bitfield Name	RW	Default	Description
[31:8]	Rsvd	R	000000h	Reserved
[7]	Long Form	R	0	Indicates that the connection list items are in short form
[6:0]	Connection List Length	R	01h	Indicates that there is 1 NID entry in the connection list

Supported Power States Parameter (PID = 0Fh)

Bit	Bitfield Name	RW	Default	Description
[31:4]	Rsvd	R	0000000h	Reserved
[3]	D3Sup	R	1	D3 power state supported
[2]	D2Sup	R	1	D2 power state supported
[1]	D1sup	R	1	D1 power state supported
[0]	D0Sup	R	1	D0 power state supported

Processing Capabilities Parameter (PID = 10h)

Bit	Bitfield Name	RW	Default	Description
[31:16]	Rsvd	R	0000h	Reserved
[15:8]	NumCoeff	R	00h	This widget does not support loadable coefficients
[7:1]	Rsvd	R	00h	Reserved
[0]	Benign	R	0	The "Processing Benign State" is not supported

GET CONNECTION LIST ENTRY VERB

	Verb ID	Payload [7:0]	Response[31:0]
Get	F02h	00h	Bits [31:0] in the table below

Bit	Bitfield Name	RW	Default	Description
[31:24]	Conn List Entry 3	R	00h	Unused connection list entry
[23:16]	Conn List Entry 2	R	00h	Unused connection list entry
[15:8]	Conn List Entry 1	R	00h	Unused connection list entry
[7:0]	Conn List Entry 0	R	0Ah	Indicates that the ADC1 widget node connects to the PGA1 widget node (NID = 0Ah)

PROCESSING STATE VERB

	Verb ID	Payload [7:0]	Response[31:0]
Get	F03h	00h	Bits [31:0] in the table below
Set	703h	Bits [7:0] in the table below	00000000h

Bit	Bitfield Name	RW	Default	Description
[31:8]	Rsvd	R	000000h	Reserved
[7:0]	Processing State	RW	01h	The processing block is the high-pass filter (HPF). The processing state is controlled as follows: 00h = Processing Off: HPF disabled 01h = Processing On: HPF enabled 02h = Processing Off: HPF disabled (benign not supported) 03h-7Fh = Reserved 80h-FFh = Vendor Specific – not used

POWER STATE VERB

	Verb ID	Payload [7:0]	Response[31:0]
Get	F05h	00h	Bits [31:0] in the table below
Set	705h	Bits [7:0] in the table below	00000000h

Bit	Bitfield Name	RW	Default	Description
[31:8]	Rsvd	R	000000h	Reserved
[7:4]	PS-Act	R	3h	Indicates the actual power state of the ADC1 widget node: 0h = D0 1h = D1 2h = D2 3h = D3 Note: The power state of the ADC1 widget node is controlled by <i>PS-Set</i> below, however the control may be superseded by the <i>PS-Set</i> of the AFG widget node.
[3:0]	PS-Set	RW	3h	Sets the power state of the ADC1 widget node: 0h = D0 1h = D1 2h = D2 3h = D3

CONVERTER STREAM, CHANNEL VERB

	Verb ID	Payload [7:0]	Response[31:0]
Get	F06h	00h	Bits [31:0] in the table below
Set	706h	Bits [7:0] in the table below	00000000h

Bit	Bitfield Name	RW	Default	Description
[31:8]	Rsvd	R	000000h	Reserved
[7:4]	Stream	RW	0h	Stream ID used by this widget. Note that Stream ID = 0h is used to indicate an unused stream, and converters will not transfer/receive link data for streams with an ID of 0.
[3:0]	Channel	RW	0h	Lowest channel number used by this widget. Note: as this widget does not support multi-channel capture, only a setting of 0h is applicable.

UNSOLICITED RESPONSE VERB

	Verb ID	Payload [7:0]	Response[31:0]
Get	F08h	00h	Bits [31:0] in the table below
Set	708h	Bits [7:0] in the table below	00000000h

Bit	Bitfield Name	RW	Default	Description
[31:8]	Rsvd	R	000000h	Reserved
[7]	Enable	RW	0	0 = Unsolicited Responses disabled for this node 1 = Unsolicited Responses enabled for this node
[6]	Rsvd	R	0	Reserved
[5:0]	Tag	RW	02h	A software programmable tag value that is returned in the top six bits (31:26) of every Unsolicited Response from this node. The default for <i>Tag</i> is equal to the Node ID.

Note: The Unsolicited Response for the AFG node is defined in the "Unsolicited Responses" section.

UNSOLICITED RESPONSE PRIORITY CONTROL VERB (VENDOR-SPECIFIC)

	Verb ID	Payload [7:0]	Response[31:0]
Get	F8Eh	00h	Bits [31:0] in the table below
Set	78Eh	Bits [7:0] in the table below	00000000h

Bit	Bitfield Name	RW	Default	Description
[31:5]	Rsvd	R	00000000h	Reserved
[4:0]	Priority	RW	00h	Assigns a priority setting for queued Unsolicited Responses. Nodes with the lowest value have the highest priority, and so go to the front of the Unsolicited Response queue. Nodes with the same value for priority are queued on first-to-trigger basis. 00h = Highest priority ... 1Fh = Lowest priority

CHANNEL COPY VERB (VENDOR-SPECIFIC)

	Verb ID	Payload [7:0]	Response[31:0]
Get	FB1h	00h	Bits [31:0] in the table below
Set	7B1h	Bits [7:0] in the table below	00000000h

Bit	Bitfield Name	RW	Default	Description
[31:2]	Rsvd	R	00000000h	Reserved
[1]	CHAN1_SEL	RW	1	Channel 1 (right) Mapping Control: 0 = Channel 1 takes data from left audio channel 1 = Channel 1 takes data from right audio channel
[0]	CHAN0_SEL	RW	0	Channel 0 (left) Mapping Control: 0 = Channel 0 takes data from left audio channel 1 = Channel 0 takes data from right audio channel

MIC1 AUDIO INPUT CONVERTER WIDGET (NID = 03H)
STREAM FORMAT VERB

	Verb ID	Payload [15:0]	Response[31:0]
Get	Ah	0000h	Bits [31:0] in the table below
Set	2h	Bits [15:0] in the table below	00000000h

Bit	Bitfield Name	RW	Default	Description
[31:16]	Rsvd	R	0000h	Reserved
[15]	Type	R	0	Indicates the widget supports only PCM streams
[14]	Base	RW	0	Used to set the base rate frequency: 0 = 48 kHz 1 = 44.1 kHz
[13:11]	Mult	RW	0h	Used to set the base rate multiplication factor: 0h = x1 (48kHz, 44.1kHz or less) 1h = x2 (32kHz) 2h-7h = Reserved
[10:8]	Div	RW	0h	Used to set the base rate division factor: 0h = divide by 1 (48kHz, 44.1kHz) 1h = divide by 2 (24kHz, 22.05kHz) 2h = divide by 3 (16kHz, 32kHz) 3h = divide by 4 (11.025kHz) 4h = Reserved 5h = divide by 6 (8kHz) 6h = Reserved 7h = Reserved
[7]	Rsvd	R	0	Reserved
[6:4]	Bits	RW	3h	Bits per Sample: 0h = Reserved 1h = 16 bits 2h = 20 bits 3h = 24 bits 4h = 32 bits (Float 32) 5h-7h = Reserved
[3:0]	Chan	RW	1h	Number of Channels in each frame of the stream: 0h = 1 channel 1h = 2 channels 2h = 3 channels 3h = 4 channels 4h-Fh = reserved

GET PARAMETER VERB

	Verb ID	Payload [7:0]	Response[31:0]
Get	F00h	Parameter ID (PID)	Parameter Value

Audio Widget Capabilities Parameter (PID = 09h)

Bit	Bitfield Name	RW	Default	Description
[31:24]	Rsvd	R	00h	Reserved
[23:20]	Type	R	1h	Indicates that this is an Audio Input widget
[19:16]	Delay	R	0h	Latency not reported
[15:12]	Rsvd	R	0h	Reserved
[11]	L-R Swap	R	0	Left/Right swap capability not supported
[10]	PowerCntrl	R	1	Indicates that the <i>Power State Verb</i> is supported in this widget
[9]	Digital	R	0	Indicates that this widget is translating analogue data
[8]	Conn List	R	1	Indicates that a connection list is present
[7]	Unsol Capable	R	1	Widget supports Unsolicited Responses
[6]	ProcWidget	R	1	Widget has processing capabilities (i.e high pass filter)
[5]	Stripe	R	0	Widget does not support striping
[4]	Format Override	R	1	Widget has a subset of the supported rates defined for the AFG
[3]	Amp Parameter Override	R	0	Not applicable as this widget does not have amplifier capabilities
[2]	Out Amp Present	R	0	Output amplifier not present in this widget
[1]	In Amp Present	R	0	Input amplifier not present in this widget
[0]	Stereo	R	1	Indicates that this is a stereo widget

Supported Rates Parameter (PID = 0Ah)

Bit	Bitfield Name	RW	Default	Description
[31:21]	Rsvd	R	000h	Reserved
[20]	B32	R	1	MIC1 supports 32-bit audio format
[19]	B24	R	1	MIC1 supports 24-bit audio format
[18]	B20	R	1	MIC1 supports 20-bit audio format
[17]	B16	R	1	MIC1 supports 16-bit audio format
[16]	B8	R	0	MIC1 does not support 8-bit audio format
[15:12]	Rsvd	R	0h	Reserved
[11]	R12	R	0	MIC1 does not support 384 kHz sample rate
[10]	R11	R	0	MIC1 does not support 192 kHz sample rate
[9]	R10	R	0	MIC1 does not support 176.4 kHz sample rate
[8]	R9	R	0	MIC1 does not support 96 kHz sample rate
[7]	R8	R	0	MIC1 does not support 88.2 kHz sample rate
[6]	R7	R	1	MIC1 supports 48 kHz sample rate
[5]	R6	R	1	MIC1 supports 44.1 kHz sample rate
[4]	R5	R	1	MIC1 supports 32 kHz sample rate
[3]	R4	R	1	MIC1 supports 22.05 kHz sample rate
[2]	R3	R	1	MIC1 supports 16 kHz sample rate
[1]	R2	R	1	MIC1 supports 11.025 kHz sample rate
[0]	R1	R	1	MIC1 supports 8 kHz sample rate

Supported Stream Formats Parameter (PID = 0Bh)

Bit	Bitfield Name	RW	Default	Description
[31:3]	Rsvd	R	00000000h	Reserved
[2]	AC3	R	0	MIC1 does not support Dolby AC3 formatted data
[1]	Float32	R	1	MIC1 supports Float32 formatted data
[0]	PCM	R	1	MIC1 supports PCM formatted data

Connection List Length Parameter (PID = 0Eh)

Bit	Bitfield Name	RW	Default	Description
[31:8]	Rsvd	R	0000000h	Reserved
[7]	Long Form	R	0	Indicates that the connection list items are in short form
[6:0]	Connection List Length	R	01h	Indicates that there is 1 NID entry in the connection list

Supported Power States Parameter (PID = 0Fh)

Bit	Bitfield Name	RW	Default	Description
[31:4]	Rsvd	R	0000000h	Reserved
[3]	D3Sup	R	1	D3 power state supported
[2]	D2Sup	R	1	D2 power state supported
[1]	D1sup	R	1	D1 power state supported
[0]	D0Sup	R	1	D0 power state supported

Processing Capabilities Parameter (PID = 10h)

Bit	Bitfield Name	RW	Default	Description
[31:16]	Rsvd	R	0000h	Reserved
[15:8]	NumCoeff	R	00h	This widget does not support loadable coefficients
[7:1]	Rsvd	R	00h	Reserved
[0]	Benign	R	0	The "Processing Benign State" is not supported

GET CONNECTION LIST ENTRY VERB

	Verb ID	Payload [7:0]	Response[31:0]
Get	F02h	00h	Bits [31:0] in the table below

Bit	Bitfield Name	RW	Default	Description
[31:24]	Conn List Entry 3	R	00h	Unused connection list entry
[23:16]	Conn List Entry 2	R	00h	Unused connection list entry
[15:8]	Conn List Entry 1	R	00h	Unused connection list entry
[7:0]	Conn List Entry 0	R	09h	Indicates that the MIC1 Widget connects to the MIC1 Mux Widget (NID = 09h)

PROCESSING STATE VERB

	Verb ID	Payload [7:0]	Response[31:0]
Get	F03h	00h	Bits [31:0] in the table below
Set	703h	Bits [7:0] in the table below	00000000h

Bit	Bitfield Name	RW	Default	Description
[31:8]	Rsvd	R	000000h	Reserved
[7:0]	Processing State	RW	01h	The processing node is the high-pass filter (HPF). The processing state is controlled as follows: 00h = Processing Off: HPF disabled 01h = Processing On: HPF enabled 02h = Processing Off: HPF disabled (benign not supported) 03h-7Fh = Reserved 80h-FFh = Vendor Specific – not used

POWER STATE VERB

	Verb ID	Payload [7:0]	Response[31:0]
Get	F05h	00h	Bits [31:0] in the table below
Set	705h	Bits [7:0] in the table below	00000000h

Bit	Bitfield Name	RW	Default	Description
[31:8]	Rsvd	R	000000h	Reserved
[7:4]	PS-Act	R	3h	Indicates the actual power state of the MIC1 widget node: 0h = D0 1h = D1 2h = D2 3h = D3 The power state of the MIC1 widget is controlled by <i>PS-Set</i> below, however the control may be superseded by the <i>PS-Set</i> of the AFG node.
[3:0]	PS-Set	RW	3h	Sets the power state of the MIC1 widget node: 0h = D0 1h = D1 2h = D2 3h = D3

CONVERTER STREAM, CHANNEL VERB

	Verb ID	Payload [7:0]	Response[31:0]
Get	F06h	00h	Bits [31:0] in the table below
Set	706h	Bits [7:0] in the table below	00000000h

Bit	Bitfield Name	RW	Default	Description
[31:8]	Rsvd	R	0000000h	Reserved
[7:4]	Stream	RW	0h	Stream ID used by this widget. Note that Stream ID = 0h is used to indicate an unused stream, and converters will not transfer/receive link data for streams with an ID of 0h. For multi-channel capture on MIC1 and MIC2, the <i>Stream</i> value should be the same for both.
[3:0]	Channel	RW	0h	Lowest channel number used by this widget. Note: When MIC1 and MIC2 are setup for multi-channel capture, only a setting of 0h and 2h are applicable. However, the values are mutually exclusive, in that if <i>Channel</i> has been set to 0h for the MIC1 node, it must be set to 2h for the MIC2 node. Both nodes should have <i>Channel</i> set to 0h when not in multi-channel capture mode.

UNSOLICITED RESPONSE VERB

	Verb ID	Payload [7:0]	Response[31:0]
Get	F08h	00h	Bits [31:0] in the table below
Set	708h	Bits [7:0] in the table below	00000000h

Bit	Bitfield Name	RW	Default	Description
[31:8]	Rsvd	R	0000000h	Reserved
[7]	Enable	RW	0	0 = Unsolicited Responses disabled for this node 1 = Unsolicited Responses enabled for this node
[6]	Rsvd	R	0	Reserved
[5:0]	Tag	RW	03h	A software programmable tag value that is returned in the top six bits (31:26) of every Unsolicited Response from this node. The default for <i>Tag</i> is equal to the Node ID.

Note: The Unsolicited Response for the AFG node is defined in the "Unsolicited Responses" section.

UNSOLICITED RESPONSE PRIORITY CONTROL VERB (VENDOR-SPECIFIC)

	Verb ID	Payload [7:0]	Response[31:0]
Get	F8Eh	00h	Bits [31:0] in the table below
Set	78Eh	Bits [7:0] in the table below	00000000h

Bit	Bitfield Name	RW	Default	Description
[31:5]	Rsvd	R	00000000h	Reserved
[4:0]	Priority	RW	00h	Assigns a priority setting for queued Unsolicited Responses. Nodes with the lowest value have the highest priority, and so go to the front of the Unsolicited Response queue. Nodes with the same value for priority are queued on first-to-trigger basis. 00h = Highest priority ... 1Fh = Lowest priority

CHANNEL COPY VERB (VENDOR-SPECIFIC)

	Verb ID	Payload [7:0]	Response[31:0]
Get	FB1h	00h	Bits [31:0] in the table below
Set	7B1h	Bits [7:0] in the table below	00000000h

Bit	Bitfield Name	RW	Default	Description
[31:2]	Rsvd	R	00000000h	Reserved
[1]	CHAN1_SEL	RW	1	Channel 1 (right) Mapping Control: 0 = Channel 1 takes data from left audio channel 1 = Channel 1 takes data from right audio channel
[0]	CHAN0_SEL	RW	0	Channel 0 (left) Mapping Control: 0 = Channel 0 takes data from left audio channel 1 = Channel 0 takes data from right audio channel

S/PDIF TX 1 AUDIO OUTPUT CONVERTER WIDGET (NID = 04H)
STREAM FORMAT VERB

	Verb ID	Payload [15:0]	Response[31:0]
Get	Ah	0000h	Bits [31:0] in the table below
Set	2h	Bits [15:0] in the table below	00000000h

Bit	Bitfield Name	RW	Default	Description
[31:16]	Rsvd	R	0000h	Reserved
[15]	Type	RW	0	Used to set the format of the stream: 0 = PCM 1 = Non-PCM (i.e. AC3 or Software Formatted S/PDIF)
[14]	Base	RW	0	Used to set the base rate frequency: 0h = 48 kHz 1h = 44.1 kHz
[13:11]	Mult	RW	0h	Used to set the base rate multiplication factor: 0h = x1 (48kHz, 44.1kHz or less) 1h = x2 (96kHz, 88.2kHz, 32kHz) 2h = Reserved 3h = x4 (192kHz, 176.4kHz) 4h-7h = Reserved
[10:8]	Div	RW	0h	Used to set the base rate division factor: 0h = divide by 1 (48kHz, 44.1kHz) 1h = Reserved 2h = divide by 3 (32kHz) 3h-7h = Reserved
[7]	Rsvd	R	0	Reserved
[6:4]	Bits	RW	4h	Bits per Sample: 0h = Reserved 1h = 16 bits 2h = 20 bits 3h = 24 bits 4h = 32 bits (Software Formatted or Float 32) 5h-7h = Reserved
[3:0]	Chan	RW	1h	Number of Channels in each frame of the stream: 0h = 1 channel 1h = 2 channels 2h-Fh = reserved

Notes:

- When the internal path (of ADC1 or MIC1 or MIC2) to S/PDIF TX 1 is active, *Mult*, *Base* & *Div* become read only and are programmed by the WM8850 to match the sourced node settings.
- When Software Formatted S/PDIF is selected, and the S/PDIF TX 1 is sourcing the HDA Link, the S/PDIF output is driven low until stream ID is assigned.

GET PARAMETER VERB

	Verb ID	Payload [7:0]	Response[31:0]
Get	F00h	Parameter ID (PID)	Parameter Value

Audio Widget Capabilities Parameter (PID = 09h)

Bit	Bitfield Name	RW	Default	Description
[31:24]	Rsvd	R	00h	Reserved
[23:20]	Type	R	0h	Indicates that this is an Audio Output Widget
[19:16]	Delay	R	0h	Latency not reported
[15:12]	Rsvd	R	0h	Reserved
[11]	L-R Swap	R	0	Left/Right swap capability not supported
[10]	PowerCntrl	R	0	Indicates that the <i>Power State Verb</i> is supported in this widget
[9]	Digital	R	1	Indicates that this widget is translating digital data
[8]	Conn List	R	0	Indicates that a connection list is not present
[7]	Unsol Capable	R	1	Widget supports Unsolicited Responses
[6]	ProcWidget	R	1	Widget has processing capabilities (i.e SRC2)
[5]	Stripe	R	0	Widget does not support striping
[4]	Format Override	R	1	Widget has a subset of the supported rates defined for the AFG
[3]	Amp Parameter Override	R	0	Not applicable as this widget does not have amplifier capabilities
[2]	Out Amp Present	R	0	Output amplifier not present in this widget
[1]	In Amp Present	R	0	Input amplifier not present in this widget
[0]	Stereo	R	1	Indicates that this is a stereo widget

Supported Rates Parameter (PID = 0Ah)

Bit	Bitfield Name	RW	Default	Description
[31:21]	Rsvd	R	000h	Reserved
[20]	B32	R	1	Float32 and Software Formatted S/PDIF is supported.
[19]	B24	R	1	S/PDIF Tx 1 supports 24-bit audio format
[18]	B20	R	1	S/PDIF Tx 1 supports 20-bit audio format
[17]	B16	R	1	S/PDIF Tx 1 supports 16-bit audio format
[16]	B8	R	0	S/PDIF Tx 1 does not support 8-bit audio format
[15:12]	Rsvd	R	0h	Reserved
[11]	R12	R	0	S/PDIF Tx 1 does not support 384 kHz sample rate
[10]	R11	R	1	S/PDIF Tx 1 supports 192 kHz sample rate
[9]	R10	R	1	S/PDIF Tx 1 supports 176.4 kHz sample rate
[8]	R9	R	1	S/PDIF Tx 1 supports 96 kHz sample rate
[7]	R8	R	1	S/PDIF Tx 1 supports 88.2 kHz sample rate
[6]	R7	R	1	S/PDIF Tx 1 supports 48 kHz sample rate
[5]	R6	R	1	S/PDIF Tx 1 supports 44.1 kHz sample rate
[4]	R5	R	1	S/PDIF Tx 1 supports 32 kHz sample rate
[3]	R4	R	0	S/PDIF Tx 1 does not support 22.05 kHz sample rate
[2]	R3	R	0	S/PDIF Tx 1 does not support 16 kHz sample rate
[1]	R2	R	0	S/PDIF Tx 1 does not support 11.025 kHz sample rate
[0]	R1	R	0	S/PDIF Tx 1 does not support 8 kHz sample rate

Supported Stream Formats Parameter (PID = 0Bh)

Bit	Bitfield Name	RW	Default	Description
[31:3]	Rsvd	R	00000000h	Reserved
[2]	AC3	R	0	S/PDIF Tx 1 does not support Dolby AC3 format
[1]	Float32	R	1	S/PDIF Tx 1 supports Float32 formatted data
[0]	PCM	R	1	S/PDIF Tx 1 supports PCM formatted data

Processing Capabilities Parameter (PID = 10h)

Bit	Bitfield Name	RW	Default	Description
[31:16]	Rsvd	R	0000h	Reserved
[15:8]	NumCoeff	R	00h	This widget does not support loadable coefficients
[7:1]	Rsvd	R	00h	Reserved
[0]	Benign	R	0	The "Processing Benign State" is not supported

PROCESSING STATE VERB

	Verb ID	Payload [7:0]	Response[31:0]
Get	F03h	00h	Bits [31:0] in the table below
Set	703h	Bits [7:0] in the table below	00000000h

Bit	Bitfield Name	RW	Default	Description
[31:8]	Rsvd	R	000000h	Reserved
[7:0]	Processing State	RW	00h	The processing block for the S/PDIF Tx 1 widget node is SRC2. The processing state is controlled as follows: 00h = Processing Off: SRC2 bypassed 01h = Processing On: SRC2 used 02h = Processing Off: SRC2 bypassed (benign not supported) 03h-7Fh = Reserved 80h-FFh = Vendor Specific – not used

Notes:

1. When the S/PDIF transmitter is linked to the S/PDIF receiver (i.e. in Linked Mode), SRC2 is automatically enabled by the CODEC, and the processing state register is read only.
2. When Software Formatted S/PDIF is selected, SRC2 is automatically bypassed, and the processing state register is read only.
3. When the internal path (of ADC1 or MIC1 or MIC2) to S/PDIF Tx 1 is active, SRC2 is automatically bypassed

CONVERTER STREAM, CHANNEL VERB

	Verb ID	Payload [7:0]	Response[31:0]
Get	F06h	00h	Bits [31:0] in the table below
Set	706h	Bits [7:0] in the table below	00000000h

Bit	Bitfield Name	RW	Default	Description
[31:8]	Rsvd	R	000000h	Reserved
[7:4]	Stream	RW	0h	Stream ID used by this widget. Note that Stream ID = 0h is used to indicate an unused stream, and converters will not transfer/receive link data for streams with an ID of 0.
[3:0]	Channel	RW	0h	Lowest channel number used by this widget. Note: As this widget does not support multi-channel capture, only a setting of 0 is applicable.

UNSOLICITED RESPONSE VERB

	Verb ID	Payload [7:0]	Response[31:0]
Get	F08h	00h	Bits [31:0] in the table below
Set	708h	Bits [7:0] in the table below	00000000h

Bit	Bitfield Name	RW	Default	Description
[31:8]	Rsvd	R	000000h	Reserved
[7]	Enable	RW	0	0 = Unsolicited Responses disabled for this node 1 = Unsolicited Responses enabled for this node
[6]	Rsvd	R	0	Reserved
[5:0]	Tag	RW	04h	A software programmable tag value that is returned in the top six bits (31:26) of every Unsolicited Response from this node. The default for <i>Tag</i> is equal to the Node ID.

Note: The Unsolicited Response for the AFG node is defined in the "Unsolicited Responses" section.

S/PDIF CONVERTER CONTROL VERB

	Verb ID	Payload [7:0]	Response[31:0]
Get	F0Dh	0000h	Bits [31:0] in the table below
Set1	70Dh	Bits [7:0] in the table below	00000000h
Set2	70Eh	Bits [15:8] in the table below	00000000h

Bit	Bitfield Name	RW	Default	Description
[31:15]	Rsvd	R	00000h	Reserved
[14:8]	CC	RW	00h	Category Code. Channel Status bits [14:8] – see IEC 60958-3 for details.
[7]	L	RW	0	Generation Level, Channel Status bit [15] - see IEC 60958-3 for details.
[6]	PRO	RW	0	Professional, Channel Status bit[0]: 0 = Consumer Channel Status (40-bits) 1 = Professional Channel Status (192-bits)
[5]	/AUDIO	RW	0	Non-Audio, Channel Status bit[1]: 0 = PCM formatted data 1 = non-PCM formatted data
[4]	COPY	RW	0	Copyright, Channel Status bit[2]: 0 = indicates copyright asserted (i.e. S/PDIF Channel Status bit[2] set to 1) 1 = indicates no copyright asserted (i.e. S/PDIF Channel Status bit[2] set to 0) Note: The HDA specification, and the IEC 60958-3 specification are the inverse of each other. To comply with both, the WM8850 inverts the written value.
[3]	PRE	RW	0	Pre-emphasis, Channel Status bit[3]: 0 = no pre-emphasis 1 = 50/15 us pre-emphasis
[2]	VCFG	RW	0	Validity Configuration Control - determines what happens to the audio data, should an invalid sample occur (invalid samples occur when SRC2 is in use but not locked, EF_STREAM_ERR is asserted, or the stream ID is 0). 0 = pass data as received by the S/PDIF Tx 1. 1 = overwrite invalid data with all zeros (for the invalid sub frame only).
[1]	V	RW	0	Validity: 0 = Indicates valid data 1 = Indicates invalid data If V=1, the transmitted <i>validity</i> flag is set to 1. If V=0, the transmitted <i>validity</i> flag is set to 1 if there is an invalid sample being transmitted. Invalid samples may occur when SRC2 is in use but not locked, EF_STREAM_ERR is asserted, or the stream ID is 0.
[0]	DigEn	RW	0	Digital Enable: 0 = S/PDIF audio path disabled 1 = S/PDIF audio path enabled

Note: When Software Formatted S/PDIF is selected, verb settings for channel status and validity are not used

INTERNAL PATH VERB (VENDOR-SPECIFIC)

	Verb ID	Payload [7:0]	Response[31:0]
Get	F73h	00h	Bits [31:0] in the table below
Set1	773h	Bits [7:0] in the table below	00000000h

Bit	Bitfield Name	RW	Default	Description
[31:8]	Rsvd	R	0000000h	Reserved
[7:0]	Path Sel	RW	00h	Selects source of S/PDIF TX 1 node: 00h = HDA Link 02h = ADC1 03h = MIC1 15h = MIC2 All other values of Path Sel are reserved.

Note: When the internal path (of ADC1 or MIC1 or MIC2) to S/PDIF TX 1 is active, SRC2 is automatically bypassed and *Mult*, *Base* & *Div* (in the *Stream Format Verb*) become read only and are programmed by the WM8850 to match the sourced node settings.

S/PDIF VERB (VENDOR-SPECIFIC)

	Verb ID	Payload [7:0]	Response[31:0]
Get	F80h	00h	Bits [31:0] in the table below
Set	780h	Bits [7:0] in the table below	00000000h

Bit	Bitfield Name	RW	Default	Description
[31:9]	Rsvd	R	00000000h	Reserved
[8]	SRC_LOCK	R	0	SRC2 Lock Flag: 0 = Unlocked 1 = Locked
[7]	SRC_BASE	RW	0	Used to set the base rate frequency: 0 = 48 kHz 1 = 44.1 kHz
[6:4]	SRC_MULT	RW	0h	Used to set the base rate multiplication factor: 0h = x1 (48 kHz, 44.1 kHz or less) 1h = x2 (96 kHz, 88.2 kHz, 32 kHz) 2h = Reserved 3h = x4 (192 kHz, 176.4 kHz) 4h-7h = Reserved
[3:1]	SRC_DIV	RW	0h	Used to set the base rate division factor: 0h = divide by 1 (48 kHz, 44.1 kHz) 1h = Reserved 2h = divide by 3 (32 kHz) 3h-7h = Reserved
[0]	LINKED_MODE	RW	0	Linked Mode Control: 0 = Linked Mode disabled. S/PDIF Tx 1 and S/PDIF Rx are not linked and can operate at independent sample rates. The S/PDIF Tx 1 sample rate is determined by the <i>Stream Format Verb</i> , or, in the case where SRC2 is enabled, the sample rate is determined by <i>Base</i> , <i>Mult</i> and <i>Div</i> above. 1 = Link Mode enabled. S/PDIF Tx 1 is linked to S/PDIF Rx, and operates at a rate (configured by <i>SRC_MULT</i> and <i>SRC_DIV</i> above) that is synchronous with the recovered sample rate.

TX CHANNEL STATUS CONTROL VERB (VENDOR-SPECIFIC)

	Verb ID	Payload [7:0]	Response[31:0]
Get	F81h	00h	Bits [31:0] in the table below
Set1	781h	Bits [7:0] in the table below	00000000h
Set2	782h	Bits [15:8] in the table below	00000000h
Set3	783h	Bits [23:16] in the table below	00000000h
Set4	784h	Bits [31:24] in the table below	00000000h

The bits in the table below are defined in the IEC-60958-3 Specification:

Bit	Bitfield Name	RW	Default	Description
[31:28]	Channel Status [39:36]	RW	0h	Original Sampling Frequency
[27:25]	Channel Status [35:33]	RW	5h	Sample Word Length
[24]	Channel Status [32]	RW	1	Max Word Length
[23:22]	Channel Status [31:30]	RW	0h	Channel Status [31:30]
[21:20]	Channel Status [29:28]	RW	0h	Clock Accuracy
[19:16]	Channel Status [27:24]	RW	1h	Sampling Frequency
[15:12]	Channel Status B [23:20]	RW	0h	Channel Number for Sub-Frame B
[11:8]	Channel Status [23:20]	RW	0h	Channel Number for Sub-Frame A
[7:4]	Channel Status [19:16]	RW	0h	Source Number
[3:2]	Channel Status [7:6]	RW	0h	Channel Status Mode
[1:0]	Channel Status [5:4]	RW	0h	Additional De-emphasis Information

Notes:

1. When Software Formatted S/PDIF is selected, verb settings for channel status and validity are not used.
2. The *Channel Number* for Sub-frame B is uniquely configurable – all other Channel status bits have the same value as Sub-frame A.

CHANNEL STATUS DATA PACKING CONFIGURATION VERB (VENDOR-SPECIFIC)

	Verb ID	Payload [7:0]	Response[31:0]
Get	F85h	00h	Bits [31:0] in the table below
Set	785h	Bits [7:0] in the table below	00000000h

Bit	Bitfield Name	RW	Default	Description
[31:1]	Rsvd	R	0000000h	Reserved
[0]	CSD_MODE	RW	1	S/PDIF Transmitter Channel Status Data Packing Mode: 0 = Manual mode: sample rate and data width channel status data packed from data sourced from the <i>Tx Channel Status Control Verb</i> 1 = Automatic mode: sample rate and data width channel status data packed from data sourced from the <i>Stream Verb</i> , <i>S/PDIF Verb</i> or <i>S/PDIF Rx Rate Detector</i> (depending on routing through device)

UNSOLICITED RESPONSE PRIORITY CONTROL VERB (VENDOR-SPECIFIC)

	Verb ID	Payload [7:0]	Response[31:0]
Get	F8Eh	00h	Bits [31:0] in the table below
Set	78Eh	Bits [7:0] in the table below	00000000h

Bit	Bitfield Name	RW	Default	Description
[31:5]	Rsvd	R	0000000h	Reserved
[4:0]	Priority	RW	00h	Assigns a priority setting for queued Unsolicited Responses. Nodes with the lowest value have the highest priority, and so go to the front of the Unsolicited Response queue. Nodes with the same value for priority are queued on first-to-trigger basis. 00h = Highest priority ... 1Fh = Lowest priority

S/PDIF RX AUDIO INPUT CONVERTER WIDGET (NID = 05H)
STREAM FORMAT VERB

	Verb ID	Payload [15:0]	Response[31:0]
Get	Ah	0000h	Bits [31:0] in the table below
Set	2h	Bits [15:0] in the table below	00000000h

Bit	Bitfield Name	RW	Default	Description
[31:16]	Rsvd	R	0000h	Reserved
[15]	Type	RW	0	Used to set the format of the stream: 0 = PCM 1 = Non-PCM (i.e. AC3 or Software Formatted S/PDIF)
[14]	Base	RW	0	Used to set the base rate frequency: 0 = 48 kHz 1 = 44.1 kHz
[13:11]	Mult	RW	0h	Used to set the base rate multiplication factor: 0h = x1 (48kHz, 44.1kHz or less) 1h = x2 (96kHz, 88.2kHz, 32kHz) 2h = Reserved 3h = x4 (192kHz, 176.4kHz) 4h-7h = Reserved
[10:8]	Div	RW	0h	Used to set the base rate division factor: 0h = divide by 1 (48kHz, 44.1kHz) 1h = Reserved 2h = divide by 3 (32kHz) 3h-7h = Reserved
[7]	Rsvd	R	0	Reserved
[6:4]	Bits	RW	4h	Bits per Sample: 0h = Reserved 1h = 16 bits 2h = 20 bits 3h = 24 bits 4h = 32 bits (Software Formatted or Float 32) 5h-7h = Reserved
[3:0]	Chan	RW	1h	Number of Channels in each frame of the stream: 0h = 1 channel 1h = 2 channels 2h-Fh = reserved

Notes:

- When SRC1 is disabled, registers *Base*, *Mult*, and *Div* are read only, and are determined by the recovered S/PDIF rate. When SRC1 is enabled, registers *Base*, *Mult*, and *Div* have read-write access, and are used to program the sample rate for the link and for the output side of SRC1.
- When Software Formatted S/PDIF is selected, SRC1 is automatically bypassed.

GET PARAMETER VERB

	Verb ID	Payload [7:0]	Response[31:0]
Get	F00h	Parameter ID (PID)	Parameter Value

Audio Widget Capabilities Parameter (PID = 09h)

Bit	Bitfield Name	RW	Default	Description
[31:24]	Rsvd	R	00h	Reserved
[23:20]	Type	R	1h	Indicates that this is an Audio Input Widget
[19:16]	Delay	R	0h	Latency not reported
[15:12]	Rsvd	R	0h	Reserved
[11]	L-R Swap	R	0	Left/Right swap capability not supported
[10]	PowerCntrl	R	0	Indicates that the <i>Power State Verb</i> is supported in this widget
[9]	Digital	R	1	Indicates that this widget is translating digital data
[8]	Conn List	R	1	Indicates that a connection list is present
[7]	Unsol Capable	R	1	Widget supports Unsolicited Responses
[6]	ProcWidget	R	1	Widget has processing capabilities (i.e SRC1)
[5]	Stripe	R	0	Widget does not support striping
[4]	Format Override	R	1	Widget has a subset of the supported rates defined for the AFG
[3]	Amp Parameter Override	R	0	Not applicable as this widget does not have amplifier capabilities
[2]	Out Amp Present	R	0	Output amplifier not present in this widget
[1]	In Amp Present	R	0	Input amplifier not present in this widget
[0]	Stereo	R	1	Indicates that this is a stereo widget

Supported Rates Parameter (PID = 0Ah)

Bit	Bitfield Name	RW	Default	Description
[31:21]	Rsvd	R	000h	Reserved
[20]	B32	R	1	Float32 and Software Formatted S/PDIF is supported.
[19]	B24	R	1	S/PDIF Rx supports 24-bit audio format
[18]	B20	R	1	S/PDIF Rx supports 20-bit audio format
[17]	B16	R	1	S/PDIF Rx supports 16-bit audio format
[16]	B8	R	0	S/PDIF Rx does not support 8-bit audio format
[15:12]	Rsvd	R	0h	Reserved
[11]	R12	R	0	S/PDIF Rx does not support 384 kHz sample rate
[10]	R11	R	0	S/PDIF Rx does not support 192 kHz sample rate
[9]	R10	R	0	S/PDIF Rx does not support 176.4 kHz sample rate
[8]	R9	R	1	S/PDIF Rx supports 96 kHz sample rate
[7]	R8	R	1	S/PDIF Rx supports 88.2 kHz sample rate
[6]	R7	R	1	S/PDIF Rx supports 48 kHz sample rate
[5]	R6	R	1	S/PDIF Rx supports 44.1 kHz sample rate
[4]	R5	R	1	S/PDIF Rx supports 32 kHz sample rate
[3]	R4	R	0	S/PDIF Rx does not support 22.05 kHz sample rate
[2]	R3	R	0	S/PDIF Rx does not support 16 kHz sample rate
[1]	R2	R	0	S/PDIF Rx does not support 11.025 kHz sample rate
[0]	R1	R	0	S/PDIF Rx does not support 8 kHz sample rate

Supported Stream Formats Parameter (PID = 0Bh)

Bit	Bitfield Name	RW	Default	Description
[31:3]	Rsvd	R	00000000h	Reserved
[2]	AC3	R	0	S/PDIF Rx does not support Dolby AC3 format
[1]	Float32	R	1	S/PDIF Rx supports Float32 formatted data
[0]	PCM	R	1	S/PDIF Rx supports PCM formatted data

Connection List Length Parameter (PID = 0Eh)

Bit	Bitfield Name	RW	Default	Description
[31:8]	Rsvd	R	000000h	Reserved
[7]	Long Form	R	0	Indicates that the connection list items are in short form
[6:0]	Connection List Length	R	01h	Indicates that there is 1 NID entry in the connection list

Processing Capabilities Parameter (PID = 10h)

Bit	Bitfield Name	RW	Default	Description
[31:16]	Rsvd	R	0000h	Reserved
[15:8]	NumCoeff	R	00h	This widget does not support loadable coefficients
[7:1]	Rsvd	R	00h	Reserved
[0]	Benign	R	0	The "Processing Benign State" is not supported

GET CONNECTION LIST ENTRY VERB

	Verb ID	Payload [7:0]	Response[31:0]
Get	F02h	00h	Bits [31:0] in the table below

Bit	Bitfield Name	RW	Default	Description
[31:24]	Conn List Entry 3	R	00h	Unused connection list entry
[23:16]	Conn List Entry 2	R	00h	Unused connection list entry
[15:8]	Conn List Entry 1	R	00h	Unused connection list entry
[7:0]	Conn List Entry 0	R	10h	Indicates that the S/PDIF Rx Input Widget node connects to the SPDIF_IN Pin Widget (NID = 10h)

PROCESSING STATE VERB

	Verb ID	Payload [7:0]	Response[31:0]
Get	F03h	00h	Bits [31:0] in the table below
Set	703h	Bits [7:0] in the table below	00000000h

Bit	Bitfield Name	RW	Default	Description
[31:8]	Rsvd	R	000000h	Reserved
[7:0]	Processing State	RW	00h	The processing block for the S/PDIF Rx widget node is SRC1. The processing state is controlled as follows: 00h = Processing Off: SRC1 bypassed 01h = Processing On: SRC1 used 02h = Processing Off: SRC1 bypassed (benign not supported) 03h-7Fh = Reserved 80h-FFh = Vendor Specific – not used

Note:

The Processing State Verb should be set to 00h (SRC1 bypassed) when Software Formatted S/PDIF is selected or when any S/PDIF Rx to DAC internal path is enabled. This is not done automatically.

CONVERTER STREAM, CHANNEL VERB

	Verb ID	Payload [7:0]	Response[31:0]
Get	F06h	00h	Bits [31:0] in the table below
Set	706h	Bits [7:0] in the table below	00000000h

Bit	Bitfield Name	RW	Default	Description
[31:8]	Rsvd	R	000000h	Reserved
[7:4]	Stream	RW	0h	Stream ID used by this widget. Note that Stream ID = 0 is used to indicate an unused stream, and converters will not transfer/receive link data for streams with an ID of 0.
[3:0]	Channel	RW	0h	Lowest channel number used by this widget. Note: As this widget does not support multi-channel capture, only a setting of 0 is applicable.

UNSOLICITED RESPONSE VERB

	Verb ID	Payload [7:0]	Response[31:0]
Get	F08h	00h	Bits [31:0] in the table below
Set	708h	Bits [7:0] in the table below	00000000h

Bit	Bitfield Name	RW	Default	Description
[31:8]	Rsvd	R	000000h	Reserved
[7]	Enable	RW	0	0 = Unsolicited Responses disabled for this node 1 = Unsolicited Responses enabled for this node
[6]	Rsvd	R	0	Reserved
[5:0]	Tag	RW	05h	A software programmable tag value that is returned in the top six bits (31:26) of every Unsolicited Response from this node. The default for <i>Tag</i> is equal to the Node ID.

Note: The Unsolicited Response for the AFG node is defined in the "Unsolicited Responses" section.

DIGITAL CONVERTER CONTROL VERB

	Verb ID	Payload [7:0]	Response[31:0]
Get	F0Dh	0000h	Bits [31:0] in the table below
Set	70Dh	Bit [0] in the table below	00000000h

Bit	Bitfield Name	RW	Default	Description
[31:15]	Rsvd	R	000000h	Reserved
[14:8]	CC	R	00h	Category Code. Channel Status bits [14:8] – see IEC 60958-3 for details.
[7]	L	R	0	Generation Level, Channel Status bit [15] - see IEC 60958-3 for details.
[6]	PRO	R	0	Professional, Channel Status bit[0]: 0 = Consumer Channel Status (40-bits) 1 = Professional Channel Status (192-bits)
[5]	/AUDIO	R	0	Non-Audio, Channel Status bit[1]: 0 = PCM formatted data 1 = non-PCM formatted data
[4]	COPY	R	0	Copyright, Channel Status bit[2]: 0 = indicates copyright asserted 1 = indicates no copyright asserted Note: The HDA specification and the IEC 60958-3 specification are the inverse of each other. To comply with both, the WM8850 inverts the recovered value.
[3]	PRE	R	0	Pre-emphasis, Channel Status bit[3]: 0 = no pre-emphasis 1 = 50/15 us pre-emphasis
[2]	Rsvd	R	0	Reserved
[1]	V	R	0	Validity: 0 = Indicates valid data 1 = Indicates invalid data
[0]	DigEn	RW	0	Digital Enable: 0 = S/PDIF audio path disabled 1 = S/PDIF audio path enabled

S/PDIF VERB (VENDOR-SPECIFIC)

	Verb ID	Payload [7:0]	Response[31:0]
Get	F80h	00h	Bits [31:0] in the table below

Bit	Bitfield Name	RW	Default	Description
[31:9]	Rsvd	R	00000000h	Reserved
[8]	SRC_LOCK	R	0	SRC1 Lock Flag: 0 = Unlocked 1 = Locked
[7:0]	Rsvd	R	00h	Reserved

UNSOLICITED RESPONSE PRIORITY CONTROL VERB (VENDOR-SPECIFIC)

	Verb ID	Payload [7:0]	Response[31:0]
Get	F8Eh	00h	Bits [31:0] in the table below
Set	78Eh	Bits [7:0] in the table below	00000000h

Bit	Bitfield Name	RW	Default	Description
[31:5]	Rsvd	R	0000000h	Reserved
[4:0]	Priority	RW	00h	Assigns a priority setting for queued Unsolicited Responses. Nodes with the lowest value have the highest priority, and so go to the front of the Unsolicited Response queue. Nodes with the same value for priority are queued on first-to-trigger basis. 00h = Highest priority ... 1Fh = Lowest priority

GET CHANNEL STATUS VERB (VENDOR-SPECIFIC)

	Verb ID	Payload [7:0]	Response[31:0]
Get	F91h	00h	Bits [31:0] in the table below
Get	F91h	01h	Bits [39:32] in the table below

The bits in the table below are defined in the IEC-60958-3 Specification:

Bit	Bitfield Name	RW	Default	Description
[39:36]	Original Sampling Frequency	R	N/A	Original Sampling Frequency
[35:33]	Sample Word Length	R	N/A	Sample Word Length
[32]	Max Word Length	R	N/A	Max Word Length
[31:28]	Clock Accuracy	R	N/A	Clock Accuracy
[27:24]	Sampling Frequency	R	N/A	Sampling Frequency
[23:20]	Channel Number	R	N/A	Channel Number
[19:16]	Source Number	R	N/A	Source Number
[15:8]	Category Code	R	N/A	Category Code
[7:6]	Channel Status Mode	R	N/A	Channel Status Mode
[5:4]	Additional De-emphasis Information	R	N/A	Additional De-emphasis Information
[3]	PRE	R	N/A	Pre-emphasis
[2]	/COPY	R	N/A	Copyright
[1]	/AUDIO	R	N/A	Non Audio
[0]	PRO	R	N/A	Professional/Consumer

GET NON-AUDIO FLAG VERB (VENDOR-SPECIFIC)

	Verb ID	Payload [7:0]	Response[31:0]
Get	F92h	00h	Bits [31:0] in the table below

Bit	Bitfield Name	RW	Default	Description
[31:1]	Rsvd	R	00000000h	Reserved
[0]	Non Audio Flag	R	0	Indicates the presence of the non-audio flag: 0 = non-audio flag not asserted 1 = non-audio flag asserted

OVERWRITE CONTROL VERB (VENDOR-SPECIFIC)

	Verb ID	Payload [7:0]	Response[31:0]
Get	F93h	00h	Bits [31:0] in the table below
Set	793h	Bits [7:0] in the table below	00000000h

Bit	Bitfield Name	RW	Default	Description
[31:3]	Rsvd	R	0000000h	Reserved
[2]	NA_CNTRL	RW	1	<p>Controls the conditions under which the non audio flag is asserted:</p> <p>0 = non-audio flag asserted when the non-audio code (defined in IEC-61937) is detected. Non-audio flag rescinds after 4096 S/PDIF frames without non-audio code being present.</p> <p>1 = as above, but Channel Status Bit [1] (/AUDIO) must also be set to 1 for the non-audio flag to assert. Non-audio flag rescinds in the same way as above, and in addition the flag will rescind immediately if /AUDIO were to go low.</p>
[1]	NA_OVWR_EN	RW	0	<p>If a Non-Audio Flag is asserted then sample data is overwritten with zeros when this bit is set:</p> <p>0 = no overwrite 1 = overwrite samples with zeros</p> <p>Note: When in Software Formatted S/PDIF Mode, only the 24-bit payload can be overwritten.</p> <p>Note: When SRC1 is used (i.e. <i>Processing State</i> is 01h), NA_OVWR_EN is set to 1 by the WM8850</p>
[0]	DE_OVWR_EN	RW	1	<p>If a DATA_ERR is detected, the sample is overwritten with zeros when this bit is set:</p> <p>0 = Let erroneous sample pass 1 = overwrite erroneous sample with zeros</p> <p>Note: When in Software Formatted S/PDIF Mode, all 32-bits of the stream sample are overwritten.</p>

DAC1 AUDIO OUTPUT CONVERTER WIDGET (NID = 06H)
STREAM FORMAT VERB

	Verb ID	Payload [15:0]	Response[31:0]
Get	Ah	0000h	Bits [31:0] in the table below
Set	2h	Bits [15:0] in the table below	00000000h

Bit	Bitfield Name	RW	Default	Description
[31:16]	Rsvd	R	0000h	Reserved
[15]	Type	R	0h	Indicates the widget supports only PCM streams
[14]	Base	RW	0	Used to set the base rate frequency: 0 = 48 kHz 1 = 44.1 kHz
[13:11]	Mult	RW	0h	Used to set the base rate multiplication factor: 0h = x1 (48kHz, 44.1kHz or less) 1h = x2 (96kHz, 88.2kHz, 32kHz) 2h = Reserved 3h = x4 (192kHz, 176.4kHz) 4h-7h = Reserved
[10:8]	Div	RW	0h	Used to set the base rate division factor: 0h = divide by 1 (48kHz, 44.1kHz) 1h = divide by 2 (24kHz, 22.05kHz) 2h = divide by 3 (16kHz, 32kHz) 3h = divide by 4 (11.025kHz) 4h = Reserved 5h = divide by 6 (8kHz) 6h = Reserved 7h = Reserved
[7]	Rsvd	R	0	Reserved
[6:4]	Bits	RW	3h	Bits per Sample: 0h = Reserved 1h = 16 bits 2h = 20 bits 3h = 24 bits 4h = 32 bits (Float 32) 5h-7h = Reserved
[3:0]	Chan	RW	1h	Number of Channels in each frame of the stream: 0h = 1 channel 1h = 2 channels 2h = 3 channels 3h = 4 channels 4h = 5 channels 5h = 6 channels 6h-Fh = reserved

Note: When the internal path between the S/PDIF Rx node to the DAC1, DAC2 and DAC3 nodes is active, *Mult*, *Base* & *Div* become read only and are programmed by the SPDIF_IN node to match the incoming sample rate.

AMPLIFIER GAIN/MUTE VERB

	Verb ID	Payload [15:0]	Response[31:0]
Get	Bh	A000h	Bits [31:0] in the response table below – applies to the left channel only
Get	Bh	8000h	Bits [31:0] in the response table below – applies to the right channel only
Set	3h	Bits [15:0] in the set table below	00000000h

Response Table:

Bit	Bitfield Name	RW	Default	Description
[31:8]	Rsvd	R	000000h	Reserved
[7]	Amplifier Mute	R	1	Shows the amplifier mute status of the selected channel: 0 = Normal 1 = Muted
[6:0]	Amplifier Gain	R	7Fh	Shows the amplifier gain setting (step number) for the selected channel. The actual gain applied is determined by <i>the Output Amplifier Capabilities Parameter</i> in the AFG, and is shown below for convenience: 00h = -63.5dB 01h = -63.0dB ... 0.5dB steps 7Eh = -0.5dB 7Fh = 0dB Note: If the <i>H-Phn Enable</i> register in the Port-A (NID=11h) <i>Pin Widget Control Verb</i> is set to 1, the actual gain setting applied has an offset of -8dB from the setting configured by the <i>Gain</i> register.

Set Table:

Bit	Bitfield Name	RW	Default	Description
[15]	Set Output Amp	W	1	Indicates that the programming refers to the output amplifier on this widget
[14]	Set Input Amp	W	0	Not applicable to this widget
[13]	Set Left Amp	W	1	0 = Left channel amplifier does not accept the values in <i>Mute</i> or <i>Gain</i> fields 1 = Left channel amplifier does accept the values in the <i>Mute</i> and <i>Gain</i> fields
[12]	Set Right Amp	W	1	0 = Right channel amplifier does not accept the values in <i>Mute</i> or <i>Gain</i> fields 1 = Right channel amplifier does accept the values in the <i>Mute</i> and <i>Gain</i> fields
[11:8]	Index	W	0h	Not applicable to this widget
[7]	Mute	W	1	0 = Normal operation 1 = Mute
[6:0]	Gain	W	7Fh	Step number of the gain – see <i>Amplifier Gain</i> in response table above for details of actual gain values

GET PARAMETER VERB

	Verb ID	Payload [7:0]	Response[31:0]
Get	F00h	Parameter ID (PID)	Parameter Value

Audio Widget Capabilities Parameter (PID = 09h)

Bit	Bitfield Name	RW	Default	Description
[31:24]	Rsvd	R	00h	Reserved
[23:20]	Type	R	0h	Indicates that this is an Audio Output Widget
[19:16]	Delay	R	0h	Latency not reported
[15:12]	Rsvd	R	0h	Reserved
[11]	L-R Swap	R	0	Left/Right swap capability not supported
[10]	PowerCntrl	R	1	Indicates that the <i>Power State Verb</i> is supported in this widget
[9]	Digital	R	0	Indicates that this widget is translating analogue data
[8]	Conn List	R	0	Indicates that a connection list is not present
[7]	Unsol Capable	R	1	Widget supports Unsolicited Responses
[6]	ProcWidget	R	0	Widget does not have processing capabilities
[5]	Stripe	R	0	Widget does not support striping
[4]	Format Override	R	1	Widget has a subset of the supported rates defined for the AFG
[3]	Amp Parameter Override	R	0	The AFG amplifier parameters are used for this widget
[2]	Out Amp Present	R	1	Output amplifier is present in this widget
[1]	In Amp Present	R	0	Input amplifier not present in this widget
[0]	Stereo	R	1	Indicates that this is a stereo widget

Supported Rates Parameter (PID = 0Ah)

Bit	Bitfield Name	RW	Default	Description
[31:21]	Rsvd	R	000h	Reserved
[20]	B32	R	1	DAC1 supports 32-bit audio format
[19]	B24	R	1	DAC1 supports 24-bit audio format
[18]	B20	R	1	DAC1 supports 20-bit audio format
[17]	B16	R	1	DAC1 supports 16-bit audio format
[16]	B8	R	0	DAC1 does not support 8-bit audio format
[15:12]	Rsvd	R	0h	Reserved
[11]	R12	R	0	DAC1 does not support 384 kHz sample rate
[10]	R11	R	1	DAC1 supports 192 kHz sample rate
[9]	R10	R	1	DAC1 supports 176.4 kHz sample rate
[8]	R9	R	1	DAC1 supports 96 kHz sample rate
[7]	R8	R	1	DAC1 supports 88.2 kHz sample rate
[6]	R7	R	1	DAC1 supports 48 kHz sample rate
[5]	R6	R	1	DAC1 supports 44.1 kHz sample rate
[4]	R5	R	1	DAC1 supports 32 kHz sample rate
[3]	R4	R	1	DAC1 supports 22.05 kHz sample rate
[2]	R3	R	1	DAC1 supports 16 kHz sample rate
[1]	R2	R	1	DAC1 supports 11.025 kHz sample rate
[0]	R1	R	1	DAC1 supports 8 kHz sample rate

Supported Stream Formats Parameter (PID = 0Bh)

Bit	Bitfield Name	RW	Default	Description
[31:3]	Rsvd	R	00000000h	Reserved
[2]	AC3	R	0	DAC1 does not support Dolby AC3 formatted data
[1]	Float32	R	1	DAC1 supports Float32 formatted data
[0]	PCM	R	1	DAC1 supports PCM formatted data

Supported Power States Parameter (PID = 0Fh)

Bit	Bitfield Name	RW	Default	Description
[31:4]	Rsvd	R	0000000h	Reserved
[3]	D3Sup	R	1	D3 power state supported
[2]	D2Sup	R	1	D2 power state supported
[1]	D1sup	R	1	D1 power state supported
[0]	D0Sup	R	1	D0 power state supported

POWER STATE VERB

	Verb ID	Payload [7:0]	Response[31:0]
Get	F05h	00h	Bits [31:0] in the table below
Set	705h	Bits [7:0] in the table below	00000000h

Bit	Bitfield Name	RW	Default	Description
[31:8]	Rsvd	R	0000000h	Reserved
[7:4]	PS-Act	R	3h	Indicates the actual power state of the DAC1 node: 0h = D0 1h = D1 2h = D2 3h = D3 4h-Fh = Reserved Note: The power state of the DAC1 node is controlled by <i>PS-Set</i> below, however the control may be superseded by the <i>PS-Set</i> of the AFG node.
[3:0]	PS-Set	RW	3h	Sets the power state of the DAC1 node: 0h = D0 1h = D1 2h = D2 3h = D3 4h-Fh = Reserved

CONVERTER STREAM, CHANNEL VERB

	Verb ID	Payload [7:0]	Response[31:0]
Get	F06h	00h	Bits [31:0] in the table below
Set	706h	Bits [7:0] in the table below	00000000h

Bit	Bitfield Name	RW	Default	Description
[31:8]	Rsvd	R	0000000h	Reserved
[7:4]	Stream	RW	0h	Stream ID used by this widget. Note that Stream ID = 0h is used to indicate an unused stream, and converters will not transfer/receive link data for streams with an ID of 0h.
[3:0]	Channel	RW	0h	Lowest channel number used by this widget.

UNSOLICITED RESPONSE VERB

	Verb ID	Payload [7:0]	Response[31:0]
Get	F08h	00h	Bits [31:0] in the table below
Set	708h	Bits [7:0] in the table below	00000000h

Bit	Bitfield Name	RW	Default	Description
[31:8]	Rsvd	R	0000000h	Reserved
[7]	Enable	RW	0	0 = Unsolicited Responses disabled for this node 1 = Unsolicited Responses enabled for this node
[6]	Rsvd	R	0	Reserved
[5:0]	Tag	RW	06h	A software programmable tag value that is returned in the top six bits (31:26) of every Unsolicited Response from this node. The default for <i>Tag</i> is equal to the Node ID.

Note: The Unsolicited Response for the AFG node is defined in the "Unsolicited Responses" section.

INTERNAL PATH VERB (VENDOR-SPECIFIC)

	Verb ID	Payload [7:0]	Response[31:0]
Get	F73h	00h	Bits [31:0] in the table below
Set	773h	Bits [7:0] in the table below	00000000h

Bit	Bitfield Name	RW	Default	Description
[31:8]	Rsvd	R	00000000h	Reserved
[7:0]	Path Sel	RW	00h	Selects source of DAC1 node: 0h = Channel takes data from HDA Link 5h = Channel takes data from S/PDIF Rx All other values of Path Sel are reserved. Note: When the internal path of S/PDIF Rx to DAC1 is selected, the <i>Internal Path</i> verbs in the other DAC nodes are also updated to select the S/PDIF Rx as their data source.

UNSOLICITED RESPONSE PRIORITY CONTROL VERB (VENDOR-SPECIFIC)

	Verb ID	Payload [7:0]	Response[31:0]
Get	F8Eh	00h	Bits [31:0] in the table below
Set	78Eh	Bits [7:0] in the table below	00000000h

Bit	Bitfield Name	RW	Default	Description
[31:5]	Rsvd	R	0000000h	Reserved
[4:0]	Priority	RW	00h	Assigns a priority setting for queued Unsolicited Responses. Nodes with the lowest value have the highest priority, and so go to the front of the Unsolicited Response queue. Nodes with the same value for priority are queued on first-to-trigger basis. 00h = Highest priority ... 1Fh = Lowest priority

DAC2 AUDIO OUTPUT CONVERTER WIDGET (NID = 07H)
STREAM FORMAT VERB

	Verb ID	Payload [15:0]	Response[31:0]
Get	Ah	0000h	Bits [31:0] in the table below
Set	2h	Bits [15:0] in the table below	00000000h

Bit	Bitfield Name	RW	Default	Description
[31:16]	Rsvd	R	0000h	Reserved
[15]	Type	R	0	Indicates the widget supports only PCM streams
[14]	Base	RW	0	Used to set the base rate frequency: 0 = 48 kHz 1 = 44.1 kHz
[13:11]	Mult	RW	0h	Used to set the base rate multiplication factor: 0h = x1 (48kHz, 44.1kHz or less) 1h = x2 (96kHz, 88.2kHz, 32kHz) 2h = Reserved 3h = x4 (192kHz, 176.4kHz) 4h-7h = Reserved
[10:8]	Div	RW	0h	Used to set the base rate division factor: 0h = divide by 1 (48kHz, 44.1kHz) 1h = divide by 2 (24kHz, 22.05kHz) 2h = divide by 3 (16kHz, 32kHz) 3h = divide by 4 (11.025kHz) 4h = Reserved 5h = divide by 6 (8kHz) 6h = Reserved 7h = Reserved
[7]	Rsvd	R	0	Reserved
[6:4]	Bits	RW	3h	Bits per Sample: 0h = Reserved 1h = 16 bits 2h = 20 bits 3h = 24 bits 4h = 32 bits (Float 32) 5h-7h = Reserved
[3:0]	Chan	RW	1h	Number of Channels in each frame of the stream: 0h = 1 channel 1h = 2 channels 2h = 3 channels 3h = 4 channels 4h = 5 channels 5h = 6 channels 6h-Fh = reserved

Note: When the internal path between the S/PDIF Rx node to the DAC1, DAC2 and DAC3 nodes is active, *Mult*, *Base* & *Div* become read only and are programmed by the SPDIF_IN node to match the incoming sample rate.

AMPLIFIER GAIN/MUTE VERB

	Verb ID	Payload [15:0]	Response[31:0]
Get	Bh	A000h	Bits [31:0] in the response table below – applies to the left channel only
Get	Bh	8000h	Bits [31:0] in the response table below – applies to the right channel only
Set	3h	Bits [15:0] in the set table below	00000000h

Response Table:

Bit	Bitfield Name	RW	Default	Description
[31:8]	Rsvd	R	000000h	Reserved
[7]	Amplifier Mute	R	1	Shows the amplifier mute status of the selected channel: 0 = Normal 1 = Muted
[6:0]	Amplifier Gain	R	7Fh	Shows the amplifier gain setting (step number) for the selected channel. The actual gain applied is determined by the <i>Output Amplifier Capabilities Parameter</i> in the AFG (NID = 01h), and is shown below for convenience: 00h = -63.5dB 01h = -63.0dB ... 0.5dB steps 7Eh = -0.5dB 7Fh = 0dB

Set Table:

Bit	Bitfield Name	RW	Default	Description
[15]	Set Output Amp	W	1	Indicates that the programming refers to the output amplifier on this widget
[14]	Set Input Amp	W	0	Not applicable to this widget
[13]	Set Left Amp	W	1	0 = Left channel amplifier does not accept the values in <i>Mute</i> or <i>Gain</i> fields 1 = Left channel amplifier does accept the values in the <i>Mute</i> and <i>Gain</i> fields
[12]	Set Right Amp	W	1	0 = Right channel amplifier does not accept the values in <i>Mute</i> or <i>Gain</i> fields 1 = Right channel amplifier does accept the values in the <i>Mute</i> and <i>Gain</i> fields
[11:8]	Index	W	0h	Not applicable to this widget
[7]	Mute	W	1	0 = Normal operation 1 = Mute
[6:0]	Gain	W	7Fh	Step number of the gain – see <i>Amplifier Gain</i> in response table above for details of actual gain values

GET PARAMETER VERB

	Verb ID	Payload [7:0]	Response[31:0]
Get	F00h	Parameter ID (PID)	Parameter Value

Audio Widget Capabilities Parameter (PID = 09h)

Bit	Bitfield Name	RW	Default	Description
[31:24]	Rsvd	R	00h	Reserved
[23:20]	Type	R	0h	Indicates that this is an Audio Output Widget
[19:16]	Delay	R	0h	Latency not reported
[15:12]	Rsvd	R	0h	Reserved
[11]	L-R Swap	R	0	Left/Right swap capability not supported
[10]	PowerCntrl	R	1	Indicates that the <i>Power State Verb</i> is supported in this widget
[9]	Digital	R	0	Indicates that this widget is translating analogue data
[8]	Conn List	R	0	Indicates that a connection list is not present
[7]	Unsol Capable	R	1	Widget supports Unsolicited Responses
[6]	ProcWidget	R	0	Widget does not have processing capabilities
[5]	Stripe	R	0	Widget does not support striping
[4]	Format Override	R	1	Widget has a subset of the supported rates defined for the AFG
[3]	Amp Parameter Override	R	0	The AFG amplifier parameters are used for this widget
[2]	Out Amp Present	R	1	Output amplifier is present in this widget
[1]	In Amp Present	R	0	Input amplifier not present in this widget
[0]	Stereo	R	1	Indicates that this is a stereo widget

Supported Rates Parameter (PID = 0Ah)

Bit	Bitfield Name	RW	Default	Description
[31:21]	Rsvd	R	000h	Reserved
[20]	B32	R	1	DAC2 supports 32-bit audio format
[19]	B24	R	1	DAC2 supports 24-bit audio format
[18]	B20	R	1	DAC2 supports 20-bit audio format
[17]	B16	R	1	DAC2 supports 16-bit audio format
[16]	B8	R	0	DAC2 does not support 8-bit audio format
[15:12]	Rsvd	R	0h	Reserved
[11]	R12	R	0	DAC2 does not support 384 kHz sample rate
[10]	R11	R	1	DAC2 supports 192 kHz sample rate
[9]	R10	R	1	DAC2 supports 176.4 kHz sample rate
[8]	R9	R	1	DAC2 supports 96 kHz sample rate
[7]	R8	R	1	DAC2 supports 88.2 kHz sample rate
[6]	R7	R	1	DAC2 supports 48 kHz sample rate
[5]	R6	R	1	DAC2 supports 44.1 kHz sample rate
[4]	R5	R	1	DAC2 supports 32 kHz sample rate
[3]	R4	R	1	DAC2 supports 22.05 kHz sample rate
[2]	R3	R	1	DAC2 supports 16 kHz sample rate
[1]	R2	R	1	DAC2 supports 11.025 kHz sample rate
[0]	R1	R	1	DAC2 supports 8 kHz sample rate

Supported Stream Formats Parameter (PID = 0Bh)

Bit	Bitfield Name	RW	Default	Description
[31:3]	Rsvd	R	00000000h	Reserved
[2]	AC3	R	0	DAC2 does not support Dolby AC3 formatted data
[1]	Float32	R	1	DAC2 supports Float32 formatted data
[0]	PCM	R	1	DAC2 supports PCM formatted data

Supported Power States Parameter (PID = 0Fh)

Bit	Bitfield Name	RW	Default	Description
[31:4]	Rsvd	R	0000000h	Reserved
[3]	D3Sup	R	1	D3 power state supported
[2]	D2Sup	R	1	D2 power state supported
[1]	D1sup	R	1	D1 power state supported
[0]	D0Sup	R	1	D0 power state supported

POWER STATE VERB

	Verb ID	Payload [7:0]	Response[31:0]
Get	F05h	00h	Bits [31:0] in the table below
Set	705h	Bits [7:0] in the table below	00000000h

Bit	Bitfield Name	RW	Default	Description
[31:8]	Rsvd	R	000000h	Reserved
[7:4]	PS-Act	R	3h	Indicates the actual power state of the DAC2 node: 0h = D0 1h = D1 2h = D2 3h = D3 4h-Fh = Reserved The power state of the DAC2 node is controlled by <i>PS-Set</i> below, however the control may be superseded by the <i>PS-Set</i> of the AFG node.
[3:0]	PS-Set	RW	3h	Sets the power state of the DAC2 node: 0h = D0 1h = D1 2h = D2 3h = D3 4h-Fh = Reserved

CONVERTER STREAM, CHANNEL VERB

	Verb ID	Payload [7:0]	Response[31:0]
Get	F06h	00h	Bits [31:0] in the table below
Set	706h	Bits [7:0] in the table below	00000000h

Bit	Bitfield Name	RW	Default	Description
[31:8]	Rsvd	R	000000h	Reserved
[7:4]	Stream	RW	0h	Stream ID used by this widget. Note that Stream ID = 0h is used to indicate an unused stream, and converters will not transfer/receive link data for streams with an ID of 0h.
[3:0]	Channel	RW	0h	Lowest channel number used by this widget.

UNSOLICITED RESPONSE VERB

	Verb ID	Payload [7:0]	Response[31:0]
Get	F08h	00h	Bits [31:0] in the table below
Set	708h	Bits [7:0] in the table below	00000000h

Bit	Bitfield Name	RW	Default	Description
[31:8]	Rsvd	R	0000000h	Reserved
[7]	Enable	RW	0	0 = Unsolicited Responses disabled for this node 1 = Unsolicited Responses enabled for this node
[6]	Rsvd	R	0	Reserved
[5:0]	Tag	RW	07h	A software programmable tag value that is returned in the top six bits (31:26) of every Unsolicited Response from this node. The default for <i>Tag</i> is equal to the Node ID.

Note: The Unsolicited Response for the AFG node is defined in the "Unsolicited Responses" section.

INTERNAL PATH VERB (VENDOR-SPECIFIC)

	Verb ID	Payload [7:0]	Response[31:0]
Get	F73h	00h	Bits [31:0] in the table below
Set	773h	Bits [7:0] in the table below	00000000h

Bit	Bitfield Name	RW	Default	Description
[31:8]	Rsvd	R	00000000h	Reserved
[7:0]	Path Sel	RW	00h	Selects source of DAC2 node: 0h = Channel takes data from HDA Link 5h = Channel takes data from S/PDIF Rx Note: When the internal path of S/PDIF Rx to DAC2 is selected, the <i>Internal Path</i> verbs in the other DAC nodes are also updated to select the S/PDIF Rx as their data source.

UNSOLICITED RESPONSE PRIORITY CONTROL VERB (VENDOR-SPECIFIC)

	Verb ID	Payload [7:0]	Response[31:0]
Get	F8Eh	00h	Bits [31:0] in the table below
Set	78Eh	Bits [7:0] in the table below	00000000h

Bit	Bitfield Name	RW	Default	Description
[31:5]	Rsvd	R	0000000h	Reserved
[4:0]	Priority	RW	00h	Assigns a priority setting for queued Unsolicited Responses. Nodes with the lowest value have the highest priority, and so go to the front of the Unsolicited Response queue. Nodes with the same value for priority are queued on first-to-trigger basis. 00h = Highest priority ... 1Fh = Lowest priority

DAC3 AUDIO OUTPUT CONVERTER WIDGET (NID = 08H)
STREAM FORMAT VERB

	Verb ID	Payload [15:0]	Response[31:0]
Get	Ah	0000h	Bits [31:0] in the table below
Set	2h	Bits [15:0] in the table below	00000000h

Bit	Bitfield Name	RW	Default	Description
[31:16]	Rsvd	R	0000h	Reserved
[15]	Type	R	0h	Indicates the widget supports only PCM streams
[14]	Base	RW	0	Used to set the base rate frequency: 0 = 48 kHz 1 = 44.1 kHz
[13:11]	Mult	RW	0h	Used to set the base rate multiplication factor: 0h = x1 (48kHz, 44.1kHz or less) 1h = x2 (96kHz, 88.2kHz, 32kHz) 2h = Reserved 3h = x4 (192kHz, 176.4kHz) 4h-7h = Reserved
[10:8]	Div	RW	0h	Used to set the base rate division factor: 0h = divide by 1 (48kHz, 44.1kHz) 1h = divide by 2 (24kHz, 22.05kHz) 2h = divide by 3 (16kHz, 32kHz) 3h = divide by 4 (11.025kHz) 4h = Reserved 5h = divide by 6 (8kHz) 6h = Reserved 7h = Reserved
[7]	Rsvd	R	0	Reserved
[6:4]	Bits	RW	3h	Bits per Sample: 0h = Reserved 1h = 16 bits 2h = 20 bits 3h = 24 bits 4h = 32 bits (Float 32) 5h-7h = Reserved
[3:0]	Chan	RW	1h	Number of Channels in each frame of the stream: 0h = 1 channel 1h = 2 channels 2h = 3 channels 3h = 4 channels 4h = 5 channels 5h = 6 channels 6h-Fh = reserved

Note: When the internal path between the S/PDIF Rx node to the DAC1, DAC2 and DAC3 nodes is active, *Mult*, *Base* & *Div* become read only and are programmed by the S/PDIF In node to match the incoming sample rate.

AMPLIFIER GAIN/MUTE VERB

	Verb ID	Payload [15:0]	Response[31:0]
Get	Bh	A000h	Bits [31:0] in the response table below – applies to the left channel only
Get	Bh	8000h	Bits [31:0] in the response table below – applies to the right channel only
Set	3h	Bits [15:0] in the set table below	00000000h

Response Table:

Bit	Bitfield Name	RW	Default	Description
[31:8]	Rsvd	R	000000h	Reserved
[7]	Amplifier Mute	R	1	Shows the amplifier mute status of the selected channel: 0 = Normal 1 = Muted
[6:0]	Amplifier Gain	R	7Fh	Shows the amplifier gain setting (step number) for the selected channel. The actual gain applied is determined by the <i>Output Amplifier Capabilities Parameter</i> in the AFG (NID = 01h), and is shown below for convenience: 00h = -63.5dB 01h = -63.0dB ... 0.5dB steps 7Eh = -0.5dB 7Fh = 0dB

Set Table:

Bit	Bitfield Name	RW	Default	Description
[15]	Set Output Amp	W	1	Indicates that the programming refers to the output amplifier on this widget
[14]	Set Input Amp	W	0	Not applicable to this widget
[13]	Set Left Amp	W	1	0 = Left channel amplifier does not accept the values in <i>Mute</i> or <i>Gain</i> fields 1 = Left channel amplifier accepts the values in the <i>Mute</i> and <i>Gain</i> fields
[12]	Set Right Amp	W	1	0 = Right channel amplifier does not accept the values in <i>Mute</i> or <i>Gain</i> fields 1 = Right channel amplifier accepts the values in the <i>Mute</i> and <i>Gain</i> fields
[11:8]	Index	W	0h	Not applicable to this widget
[7]	Mute	W	1	0 = Normal operation 1 = Mute
[6:0]	Gain	W	7Fh	Step number of the gain – see <i>Amplifier Gain</i> in response table above for details of actual gain values

GET PARAMETER VERB

	Verb ID	Payload [7:0]	Response[31:0]
Get	F00h	Parameter ID (PID)	Parameter Value

Audio Widget Capabilities Parameter (PID = 09h)

Bit	Bitfield Name	RW	Default	Description
[31:24]	Rsvd	R	00h	Reserved
[23:20]	Type	R	0h	Indicates that this is an Audio Output Widget
[19:16]	Delay	R	0h	Latency not reported
[15:12]	Rsvd	R	0h	Reserved
[11]	L-R Swap	R	0	Left/Right swap capability not supported
[10]	PowerCntrl	R	1	Indicates that the <i>Power State Verb</i> is supported in this widget
[9]	Digital	R	0	Indicates that this widget is translating analogue data
[8]	Conn List	R	0	Indicates that a connection list is not present
[7]	Unsol Capable	R	1	Widget supports Unsolicited Responses
[6]	ProcWidget	R	0	Widget does not have processing capabilities
[5]	Stripe	R	0	Widget does not support striping
[4]	Format Override	R	1	Widget has a subset of the supported rates defined for the AFG
[3]	Amp Parameter Override	R	0	The AFG amplifier parameters are used for this widget
[2]	Out Amp Present	R	1	Output amplifier is present in this widget
[1]	In Amp Present	R	0	Input amplifier not present in this widget
[0]	Stereo	R	1	Indicates that this is a stereo widget

Supported Rates Parameter (PID = 0Ah)

Bit	Bitfield Name	RW	Default	Description
[31:21]	Rsvd	R	000h	Reserved
[20]	B32	R	1	DAC3 supports 32-bit audio format
[19]	B24	R	1	DAC3 supports 24-bit audio format
[18]	B20	R	1	DAC3 supports 20-bit audio format
[17]	B16	R	1	DAC3 supports 16-bit audio format
[16]	B8	R	0	DAC3 does not support 8-bit audio format
[15:12]	Rsvd	R	0h	Reserved
[11]	R12	R	0	DAC3 does not support 384 kHz sample rate
[10]	R11	R	1	DAC3 supports 192 kHz sample rate
[9]	R10	R	1	DAC3 supports 176.4 kHz sample rate
[8]	R9	R	1	DAC3 supports 96 kHz sample rate
[7]	R8	R	1	DAC3 supports 88.2 kHz sample rate
[6]	R7	R	1	DAC3 supports 48 kHz sample rate
[5]	R6	R	1	DAC3 supports 44.1 kHz sample rate
[4]	R5	R	1	DAC3 supports 32 kHz sample rate
[3]	R4	R	1	DAC3 supports 22.05 kHz sample rate
[2]	R3	R	1	DAC3 supports 16 kHz sample rate
[1]	R2	R	1	DAC3 supports 11.025 kHz sample rate
[0]	R1	R	1	DAC3 supports 8 kHz sample rate

Supported Stream Formats Parameter (PID = 0Bh)

Bit	Bitfield Name	RW	Default	Description
[31:3]	Rsvd	R	00000000h	Reserved
[2]	AC3	R	0	DAC3 does not support Dolby AC3 formatted data
[1]	Float32	R	1	DAC3 supports Float32 formatted data
[0]	PCM	R	1	DAC3 supports PCM formatted data

Supported Power States Parameter (PID = 0Fh)

Bit	Bitfield Name	RW	Default	Description
[31:4]	Rsvd	R	0000000h	Reserved
[3]	D3Sup	R	1	D3 power state supported
[2]	D2Sup	R	1	D2 power state supported
[1]	D1sup	R	1	D1 power state supported
[0]	D0Sup	R	1	D0 power state supported

POWER STATE VERB

	Verb ID	Payload [7:0]	Response[31:0]
Get	F05h	00h	Bits [31:0] in the table below
Set	705h	Bits [7:0] in the table below	00000000h

Bit	Bitfield Name	RW	Default	Description
[31:8]	Rsvd	R	000000h	Reserved
[7:4]	PS-Act	R	3h	Indicates the actual power state of the DAC3 node: 0h = D0 1h = D1 2h = D2 3h = D3 4h-Fh = Reserved The power state of the DAC3 node is controlled by PS-Set below, however the control may be superseded by the PS-Set of the AFG node.
[3:0]	PS-Set	RW	3h	Sets the power state of the DAC3 node: 0h = D0 1h = D1 2h = D2 3h = D3 4h-Fh = Reserved

CONVERTER STREAM, CHANNEL VERB

	Verb ID	Payload [7:0]	Response[31:0]
Get	F06h	00h	Bits [31:0] in the table below
Set	706h	Bits [7:0] in the table below	00000000h

Bit	Bitfield Name	RW	Default	Description
[31:8]	Rsvd	R	000000h	Reserved
[7:4]	Stream	RW	0h	Stream ID used by this widget. Note that Stream ID = 0h is used to indicate an unused stream, and converters will not transfer/receive link data for streams with an ID of 0h.
[3:0]	Channel	RW	0h	Lowest channel number used by this widget.

UNSOLICITED RESPONSE VERB

	Verb ID	Payload [7:0]	Response[31:0]
Get	F08h	00h	Bits [31:0] in the table below
Set	708h	Bits [7:0] in the table below	00000000h

Bit	Bitfield Name	RW	Default	Description
[31:8]	Rsvd	R	0000000h	Reserved
[7]	Enable	RW	0	0 = Unsolicited Responses disabled for this node 1 = Unsolicited Responses enabled for this node
[6]	Rsvd	R	0	Reserved
[5:0]	Tag	RW	08h	A software programmable tag value that is returned in the top six bits (31:26) of every Unsolicited Response from this node. The default for <i>Tag</i> is equal to the Node ID.

Note: The Unsolicited Response for the AFG node is defined in the "Unsolicited Responses" section.

INTERNAL PATH VERB (VENDOR-SPECIFIC)

	Verb ID	Payload [7:0]	Response[31:0]
Get	F73h	00h	Bits [31:0] in the table below
Set	773h	Bits [7:0] in the table below	00000000h

Bit	Bitfield Name	RW	Default	Description
[31:8]	Rsvd	R	00000000h	Reserved
[7:0]	Path Sel	RW	00h	Selects source of DAC3 node: 0h = Channel takes data from HDA Link 5h = Channel takes data from S/PDIF Rx Note: When the internal path of S/PDIF Rx to DAC3 is selected, the <i>Internal Path</i> verbs in the other DAC nodes are also updated to select the S/PDIF Rx as their data source.

UNSOLICITED RESPONSE PRIORITY CONTROL VERB (VENDOR-SPECIFIC)

	Verb ID	Payload [7:0]	Response[31:0]
Get	F8Eh	00h	Bits [31:0] in the table below
Set	78Eh	Bits [7:0] in the table below	00000000h

Bit	Bitfield Name	RW	Default	Description
[31:5]	Rsvd	R	0000000h	Reserved
[4:0]	Priority	RW	00h	Assigns a priority setting for queued Unsolicited Responses. Nodes with the lowest value have the highest priority, and so go to the front of the Unsolicited Response queue. Nodes with the same value for priority are queued on first-to-trigger basis. 00h = Highest priority ... 1Fh = Lowest priority

MIC1 MUX SELECTOR WIDGET (NID = 09H)
GET PARAMETER VERB

	Verb ID	Payload [7:0]	Response[31:0]
Get	F00h	Parameter ID (PID)	Parameter Value

Audio Widget Capabilities Parameter (PID = 09h)

Bit	Bitfield Name	RW	Default	Description
[31:24]	Rsvd	R	00h	Reserved
[23:20]	Type	R	3h	Indicates that this is an Audio Selector Widget
[19:16]	Delay	R	0h	Latency not reported
[15:12]	Rsvd	R	0h	Reserved
[11]	L-R Swap	R	0	Left/Right swap capability not supported
[10]	PowerCntrl	R	0	Indicates that the <i>Power State Verb</i> is not supported in this widget
[9]	Digital	R	0	Indicates that this widget is translating analogue data
[8]	Conn List	R	1	Indicates that a connection list is present
[7]	Unsol Capable	R	0	Widget supports Unsolicited Responses
[6]	ProcWidget	R	0	Widget does not have processing capabilities
[5]	Stripe	R	0	Widget does not support striping
[4]	Format Override	R	0	Widget does not override the format defined for the AFG
[3]	Amp Parameter Override	R	0	Not applicable as this widget does not have amplifier capabilities
[2]	Out Amp Present	R	0	Output amplifier is not present in this widget
[1]	In Amp Present	R	0	Input amplifier not present in this widget
[0]	Stereo	R	1	Indicates that this is a stereo widget

Connection List Length Parameter (PID = 0Eh)

Bit	Bitfield Name	RW	Default	Description
[31:8]	Rsvd	R	000000h	Reserved
[7]	Long Form	R	0	Indicates that the connection list items are in short form
[6:0]	Connection List Length	R	02h	Indicates that there is 2 NID entries in the connection list

CONNECTION SELECT CONTROL VERB

	Verb ID	Payload [7:0]	Response[31:0]
Get	F01h	00h	Bits [31:0] in the table below
Set	701h	Bits [7:0] in the table below	00000000h

Bit	Bitfield Name	RW	Default	Description
[31:8]	Rsvd	R	000000h	Reserved
[7:0]	Connection Index	RW	00h	Connection index currently set: 00h = Connection list entry 0 01h = Connection list entry 1 02h-FFh = Reserved

GET CONNECTION LIST ENTRY VERB

	Verb ID	Payload [7:0]	Response[31:0]
Get	F02h	00h	Bits [31:0] in the table below

Bit	Bitfield Name	RW	Default	Description
[31:24]	Conn List Entry 3	R	00h	Unused connection list entry
[23:16]	Conn List Entry 2	R	00h	Unused connection list entry
[15:8]	Conn List Entry 1	R	0Eh	Indicates that the MIC1 Mux Widget connects to the Port-D Pin Widget (NID = 0Eh) Note: When the MIC1 Widget (NID=03h) is in power state D0, and the MIC1 Mux Widget sources Port-D (Digital Microphone), the analogue circuitry for the ADC, PGA, and MICBIAS is disabled to save power. Also, the DMICCLK is automatically enabled and runs at a rate determined by the MIC1 <i>Stream Format</i> verb.
[7:0]	Conn List Entry 0	R	0Bh	Indicates that the MIC1 Mux Selector Widget connects to the PGA2 Widget (NID = 0Bh)

PGA1 SELECTOR WIDGET (NID = 0AH)
AMPLIFIER GAIN/MUTE VERB

	Verb ID	Payload [15:0]	Response[31:0]
Get	Bh	A000h	Bits [31:0] in the response table below – applies to the left channel only
Get	Bh	8000h	Bits [31:0] in the response table below – applies to the right channel only
Set	3h	Bits [15:0] in the set table below	00000000h

Response Table:

Bit	Bitfield Name	RW	Default	Description
[31:8]	Rsvd	R	000000h	Reserved
[7]	Amplifier Mute	R	1	Shows the amplifier mute status of the selected channel: 0 = Normal 1 = Muted
[6:0]	Amplifier Gain	R	18h	Shows the amplifier gain setting (step number) for the selected channel. The actual gain applied is determined by the <i>Output Amplifier Capabilities Parameter</i> , and is shown below for convenience: 00h = -12dB 01h = -11.5dB ... 0.5dB steps 2Fh = +11.5dB 30h = +12dB Note: If the <i>BTL</i> register in the Port-E Pin Widget (NID=0Ch) <i>EAPD/BTL Verb</i> is set to 0, the input is single-ended and the actual gain setting applied has an offset of -3dB from the setting configured by the <i>Gain</i> register.

Set Table:

Bit	Bitfield Name	RW	Default	Description
[15]	Set Output Amp	W	1	Indicates that the programming refers to the output amplifier on this widget
[14]	Set Input Amp	W	0	Not applicable to this widget
[13]	Set Left Amp	W	1	0 = Left channel amplifier does not accept the values in <i>Mute</i> or <i>Gain</i> fields 1 = Left channel amplifier does accept the values in the <i>Mute</i> and <i>Gain</i> fields
[12]	Set Right Amp	W	1	0 = Right channel amplifier does not accept the values in <i>Mute</i> or <i>Gain</i> fields 1 = Right channel amplifier does accept the values in the <i>Mute</i> and <i>Gain</i> fields
[11:8]	Index	W	0h	Not applicable to this widget
[7]	Mute	W	1	0 = Normal operation 1 = Mute Note: When mute is applied to a channel, the data value is overwritten with all zeros.
[6:0]	Gain	W	18h	Step number of the gain – see <i>Amplifier Gain</i> in response table above for details of actual gain values

GET PARAMETER VERB

	Verb ID	Payload [7:0]	Response[31:0]
Get	F00h	Parameter ID (PID)	Parameter Value

Audio Widget Capabilities Parameter (PID = 09h)

Bit	Bitfield Name	RW	Default	Description
[31:24]	Rsvd	R	00h	Reserved
[23:20]	Type	R	3h	Indicates that this is an Audio Selector Widget
[19:16]	Delay	R	0h	Latency not reported
[15:12]	Rsvd	R	0h	Reserved
[11]	L-R Swap	R	0	Left/Right swap capability not supported
[10]	PowerCntrl	R	0	Indicates that the <i>Power State Verb</i> is not supported in this widget
[9]	Digital	R	0	Indicates that this widget is translating analogue data
[8]	Conn List	R	1	Indicates that a connection list is present
[7]	Unsol Capable	R	0	Widget supports Unsolicited Responses
[6]	ProcWidget	R	0	Widget does not have processing capabilities
[5]	Stripe	R	0	Widget does not support striping
[4]	Format Override	R	0	Widget does not override the format defined for the AFG
[3]	Amp Parameter Override	R	1	The AFG amplifier parameters are overridden for this node
[2]	Out Amp Present	R	1	Output amplifier is present in this widget
[1]	In Amp Present	R	0	Input amplifier not present in this widget
[0]	Stereo	R	1	Indicates that this is a stereo widget

Connection List Length Parameter (PID = 0Eh)

Bit	Bitfield Name	RW	Default	Description
[31:8]	Rsvd	R	000000h	Reserved
[7]	Long Form	R	0	Indicates that the connection list items are in short form
[6:0]	Connection List Length	R	01h	Indicates that there is 1 NID entries in the connection list

Output Amplifier Capabilities Response Format (PID = 12h)

Bit	Bitfield Name	RW	Default	Description
[31]	Mute Capable	R	1	PGA1 is capable of muting
[30:23]	Rsvd	R	0000h	Reserved
[22:16]	Step Size	R	01h	Gain step size is 0.5dB
[15]	Rsvd	R	0	Reserved
[14:8]	Num Steps	R	30h	Number of steps in gain range is 49 (-12dB to +12dB)
[7]	Rsvd	R	0	Reserved
[6:0]	Offset	R	18h	The step number that 0dB corresponds to is 18h

GET CONNECTION LIST ENTRY VERB

	Verb ID	Payload [7:0]	Response[31:0]
Get	F02h	00h	Bits [31:0] in the table below

Bit	Bitfield Name	RW	Default	Description
[31:24]	Conn List Entry 3	R	00h	Unused connection list entry
[23:16]	Conn List Entry 2	R	00h	Unused connection list entry
[15:8]	Conn List Entry 1	R	00h	Unused connection list entry
[7:0]	Conn List Entry 0	R	0Ch	Indicates that the PGA1 Widget connects to the Port-E Pin Widget (NID = 0Ch)

PGA CONTROL VERB (VENDOR-SPECIFIC)

	Verb ID	Payload [7:0]	Response[31:0]
Get	FB2h	00h	Bits [31:0] in the table below
Set1	7B2h	Bits [7:0] in the table below	00000000h
Set2	7B3h	Bits [15:0] in the table below	00000000h

Bit	Bitfield Name	RW	Default	Description
[31:14]	Rsvd	R	00000h	Reserved
[13:0]	Terminal Count	RW	1FFFh	Set the period of the zero detect timeout clock: 0000h = Timeout disabled 0001h to 03FFh = Reserved 0400h = 1025 x 20.833µs (21.3ms) 0401h = 1026 x 20.833µs (21.4ms) ... 1FFFh = 8192 x 20.833µs (171ms) ... 3FFFh = 16384 x 20.833µs (341ms) Note: The timeout clock uses the SYNC signal from the HDA interface, so the absolute value of the timeout period will depend on the absolute accuracy of the SYNC signal.

00h
01h
02h
03h
04h
05h
06h
07h
08h
09h
0Ah
0Bh
0Ch
0Dh
0Eh
0Fh
10h
11h
12h
13h
14h
15h
16h
17h

PGA2 SELECTOR WIDGET (NID = 0BH)
AMPLIFIER GAIN/MUTE VERB

	Verb ID	Payload [15:0]	Response[31:0]
Get	Bh	A000h	Bits [31:0] in the response table below – applies to the left channel only
Get	Bh	8000h	Bits [31:0] in the response table below – applies to the right channel only
Set	3h	Bits [15:0] in the set table below	00000000h

Response Table:

Bit	Bitfield Name	RW	Default	Description
[31:8]	Rsvd	R	000000h	Reserved
[7]	Amplifier Mute	R	1	Shows the amplifier mute status of the selected channel: 0 = Normal 1 = Muted
[6:0]	Amplifier Gain	R	18h	Shows the amplifier gain setting (step number) for the selected channel. The actual gain applied is determined by the <i>Output Amplifier Capabilities Parameter</i> , and is shown below for convenience: 00h = -12dB 01h = -11.5dB ... 0.5dB steps 2Fh = +11.5dB 30h = +12dB

Set Table:

Bit	Bitfield Name	RW	Default	Description
[15]	Set Output Amp	W	1	Indicates that the programming refers to the output amplifier on this widget
[14]	Set Input Amp	W	0	Not applicable to this widget
[13]	Set Left Amp	W	1	0 = Left channel amplifier does not accept the values in <i>Mute</i> or <i>Gain</i> fields 1 = Left channel amplifier does accept the values in the <i>Mute</i> and <i>Gain</i> fields
[12]	Set Right Amp	W	1	0 = Right channel amplifier does not accept the values in <i>Mute</i> or <i>Gain</i> fields 1 = Right channel amplifier does accept the values in the <i>Mute</i> and <i>Gain</i> fields
[11:8]	Index	W	0h	Not applicable to this widget
[7]	Mute	W	1	0 = Normal operation 1 = Mute Note: When mute is applied to a channel, the data value is overwritten with all zeros.
[6:0]	Gain	W	18h	Step number of the gain – see <i>Amplifier Gain</i> in response table above for details of actual gain values

GET PARAMETER VERB

	Verb ID	Payload [7:0]	Response[31:0]
Get	F00h	Parameter ID (PID)	Parameter Value

Audio Widget Capabilities Parameter (PID = 09h)

Bit	Bitfield Name	RW	Default	Description
[31:24]	Rsvd	R	00h	Reserved
[23:20]	Type	R	3h	Indicates that this is an Audio Selector Widget
[19:16]	Delay	R	0h	Latency not reported
[15:12]	Rsvd	R	0h	Reserved
[11]	L-R Swap	R	0	Left/Right swap capability not supported
[10]	PowerCntrl	R	0	Indicates that the <i>Power State Verb</i> is not supported in this widget
[9]	Digital	R	0	Indicates that this widget is translating analogue data
[8]	Conn List	R	1	Indicates that a connection list is present
[7]	Unsol Capable	R	0	Widget supports Unsolicited Responses
[6]	ProcWidget	R	0	Widget does not have processing capabilities
[5]	Stripe	R	0	Widget does not support striping
[4]	Format Override	R	0	Widget does not override the format defined for the AFG
[3]	Amp Parameter Override	R	1	The AFG amplifier parameters are overridden for this node
[2]	Out Amp Present	R	1	Output amplifier is present in this widget
[1]	In Amp Present	R	0	Input amplifier not present in this widget
[0]	Stereo	R	1	Indicates that this is a stereo widget

Connection List Length Parameter (PID = 0Eh)

Bit	Bitfield Name	RW	Default	Description
[31:8]	Rsvd	R	000000h	Reserved
[7]	Long Form	R	0	Indicates that the connection list items are in short form
[6:0]	Connection List Length	R	01h	Indicates that there is 1 NID entry in the connection list

Output Amplifier Capabilities Response Format (PID = 12h)

Bit	Bitfield Name	RW	Default	Description
[31]	Mute Capable	R	1	PGA2 is capable of muting
[30:23]	Rsvd	R	0000h	Reserved
[22:16]	Step Size	R	01h	Gain step size is 0.5dB
[15]	Rsvd	R	0	Reserved
[14:8]	Num Steps	R	30h	Number of steps in gain range is 49 (-12dB to +12dB)
[7]	Rsvd	R	0	Reserved
[6:0]	Offset	R	18h	The step number that 0dB corresponds to is 18h

GET CONNECTION LIST ENTRY VERB

	Verb ID	Payload [7:0]	Response[31:0]
Get	F02h	00h	Bits [31:0] in the table below

Bit	Bitfield Name	RW	Default	Description
[31:24]	Conn List Entry 3	R	00h	Unused connection list entry
[23:16]	Conn List Entry 2	R	00h	Unused connection list entry
[15:8]	Conn List Entry 1	R	00h	Unused connection list entry
[7:0]	Conn List Entry 0	R	0Dh	Indicates that the PGA2 Widget connects to the Port-B Pin Widget (NID = 0Dh)

PGA CONTROL VERB (VENDOR-SPECIFIC)

	Verb ID	Payload [7:0]	Response[31:0]
Get	FB2h	00h	Bits [31:0] in the table below
Set1	7B2h	Bits [7:0] in the table below	00000000h
Set2	7B3h	Bits [15:0] in the table below	00000000h

Bit	Bitfield Name	RW	Default	Description
[31:14]	Rsvd	R	00000h	Reserved
[13:0]	Terminal Count	RW	1FFFh	Set the period of the zero detect timeout clock: 0000h = Timeout disabled 0001h to 03FFh = Reserved 0400h = 1025 x 20.833µs (21.3ms) 0401h = 1026 x 20.833µs (21.4ms) ... 1FFFh = 8192 x 20.833µs (171ms) ... 3FFFh = 16384 x 20.833µs (341ms) Note: The timeout clock uses the SYNC signal from the HDA interface, so the absolute value of the timeout period will depend on the absolute accuracy of the SYNC signal.

00h
01h
02h
03h
04h
05h
06h
07h
08h
09h
0Ah
0Bh
0Ch
0Dh
0Eh
0Fh
10h
11h
12h
13h
14h
15h
16h
17h

PORT-E PIN COMPLEX WIDGET (NID = 0CH)
GET PARAMETER VERB

	Verb ID	Payload [7:0]	Response[31:0]
Get	F00h	Parameter ID (PID)	Parameter Value

Audio Widget Capabilities Parameter (PID = 09h)

Bit	Bitfield Name	RW	Default	Description
[31:24]	Rsvd	R	00h	Reserved
[23:20]	Type	R	4h	Indicates that this is a Pin Complex Widget
[19:16]	Delay	R	0h	Latency not reported
[15:12]	Rsvd	R	0h	Reserved
[11]	L-R Swap	R	0	Left/Right swap capability not supported
[10]	PowerCntrl	R	0	Indicates that the <i>Power State Verb</i> is not supported in this widget
[9]	Digital	R	0	Indicates that this widget is translating analogue data
[8]	Conn List	R	0	Indicates that a connection list is not present
[7]	Unsol Capable	R	1	Widget supports Unsolicited Responses
[6]	ProcWidget	R	0	Widget does not have processing capabilities
[5]	Stripe	R	0	Widget does not support striping
[4]	Format Override	R	0	Widget does not override the format defined for the AFG
[3]	Amp Parameter Override	R	0	Not applicable as this widget does not have amplifier capabilities
[2]	Out Amp Present	R	0	Output Amplifier not present in this widget
[1]	In Amp Present	R	0	Input amplifier not present in this widget
[0]	Stereo	R	1	Indicates that this is a stereo widget

Pin Capabilities Parameter (PID = 0Ch)

Bit	Bitfield Name	RW	Default	Description
[31:17]	Rsvd	R	0000h	Reserved
[16]	EAPD Capable	R	0	Widget does not support an EAPD pin
[15:8]	VRef Control	R	00h	VRef not supported
[7]	Rsvd	R	0	Reserved
[6]	Balanced I/O Pins	R	1	Indicates that this widget has balanced pins
[5]	Input Capable	R	1	Indicates that this widget is input capable
[4]	Output Capable	R	0	Indicates that this widget is not output capable
[3]	Headphone Drive Capable	R	0	Not applicable as this is an input port
[2]	Presence Detect Capable	R	1	Indicates that this widget can perform presence detection via the Pin Sense Verb
[1]	Trigger Required	R	0	Impedance measurement not supported
[0]	Impedance Sense Capable	R	0	Impedance measurement not supported

PIN WIDGET CONTROL VERB

	Verb ID	Payload [7:0]	Response[31:0]
Get	F07h	00h	Bits [31:0] in the table below
Set	707h	Bits [7:0] in the table below	00000000h

Bit	Bitfield Name	RW	Default	Description
[31:8]	Rsvd	R	000000h	Reserved
[7]	H-Phn Enable	R	0	Not applicable as this in an input port
[6]	Out Enable	R	0	Not applicable as this in an input port
[5]	In Enable	RW	1	Controls the input path: 0 = Input path is disabled 1 = Input path is enabled
[4:3]	Rsvd	R	0h	Reserved
[2:0]	VRefEn	R	0h	Selectable VRef not supported

UNSOLICITED RESPONSE VERB

	Verb ID	Payload [7:0]	Response[31:0]
Get	F08h	00h	Bits [31:0] in the table below
Set	708h	Bits [7:0] in the table below	00000000h

Bit	Bitfield Name	RW	Default	Description
[31:8]	Rsvd	R	000000h	Reserved
[7]	Enable	RW	0	0 = Unsolicited Responses disabled for this node 1 = Unsolicited Responses enabled for this node
[6]	Rsvd	R	0	Reserved
[5:0]	Tag	RW	0Ch	A software programmable tag value that is returned in the top six bits (31:26) of every Unsolicited Response from this node. The default for <i>Tag</i> is equal to the Node ID.

Note: The Unsolicited Response for the AFG node is defined in the “Unsolicited Responses” section.

PIN SENSE VERB

	Verb ID	Payload [7:0]	Response[31:0]
Get	F09h	00h	Bits [31:0] in the table below

Bit	Bitfield Name	RW	Default	Description
[31]	Presence Detect	R	0	0 = nothing plugged into Port-E 1 = something plugged into Port-E
[30:0]	Impedance Sense	R	00000000h	Impedance sense not supported

EAPD/BTL VERB

	Verb ID	Payload [7:0]	Response[31:0]
Get	F0Ch	00h	Bits [31:0] in the table below
Set	70Ch	Bits [7:0] in the table below	00000000h

Bit	Bitfield Name	RW	Default	Description
[31:1]	Rsvd	R	000000h	Reserved
[0]	BTL	RW	1	Controls the configuration of the input pins on Port-E: 0 = Single-ended mode 1 = BTL (balanced) mode

CONFIGURATION DEFAULT VERB

	Verb ID	Payload [7:0]	Response[31:0]
Get	F1Ch	00h	Bits [31:0] in the table below
Set1	71Ch	Bits [7:0] in the table below	00000000h
Set2	71Dh	Bits [15:8] in the table below	00000000h
Set3	71Eh	Bits [23:16] in the table below	00000000h
Set4	71Fh	Bits [31:24] in the table below	00000000h

Bit	Bitfield Name	RW	Default	Description
[31:30]	Port Connectivity	RW	0h	Indicates the external connectivity: 0h = Jack 1h = No physical connection 2h = A fixed function device 3h = both a jack and an internal device are connected
[29:28]	Location[5:4]	RW	0h	Gross physical location of the device connected to Port-E: 0h = External on primary chassis 1h = Internal 2h = Separate chassis 3h = Other
[27:24]	Location[3:0]	RW	1h	Geometric location of the device connected to Port-E: 0h = Not applicable 1h = Rear 2h = Front 3h = Left 4h = Right 5h = Top 6h = Bottom 7h = Special 8h = Special 9h = Special Ah-Fh = Reserved
[23:20]	Default Device	RW	8h	Indicates the intended use of Port-E: 0h = Line out 1h = Speaker 2h = Headphone out 3h = CD 4h = S/PDIF out 5h = Digital other out 6h = Modem line side 7h = Modem handset side 8h = Line in 9h = AUX Ah = Mic in Bh = Telephony Ch = S/PDIF in Dh = Digital other in Eh = Reserved Fh = Other

Bit	Bitfield Name	RW	Default	Description
[19:16]	Connection Type	RW	1h	Indicates the type of physical interface on Port-E: 0h = Unknown 1h = 3.5mm stereo/mono jack 2h = ¼" stereo/mono jack 3h = ATAPI internal 4h = RCA jack (for analogue audio or coaxial S/PDIF) 5h = Optical 6h = Other digital 7h = Other analogue 8h = Multi-channel analogue (DIN) 9h = XLR/Professional Ah = RJ-11 (modem) Bh = Combination Ch-Eh = Reserved Fh = Other
[15:12]	Colour	RW	3h	Indicates the colour of the physical jack on Port-E: 0h = Unknown 1h = Black 2h = Grey 3h = Blue 4h = Green 5h = Red 6h = Orange 7h = Yellow 8h = Purple 9h = Pink Ah-Dh = Reserved Eh = White Fh = Other
[11:8]	Misc	RW	0h	Presence detection override: 0h = Presence detection indicated by <i>Pin Capabilities Parameter</i> 1h = Presence detection not supported. If the <i>Pin Capabilities Parameter</i> indicates that that presence detection is supported by the node, then this bit is used to override it to indicate the external circuitry is not capable of supporting presence detect All other values are reserved
[7:4]	Default Association	RW	Fh	Association number: 0h = Reserved 1h-Eh = Multi Channel or Single Pin Widget Fh = Single Pin Widget Only
[3:0]	Sequence	RW	0h	Sequence number used to define individual channel pairs within a stream. All values (0h-Fh) are available for use. Use a value of 0h for Single Pin Widget.

Note: The *Configuration Default Verb* is not reset to its default value during a reset from any source. The settings are only lost when digital power is removed from the WM8850. When digital power is restored, the System BIOS must restore the settings.

UNSOLICITED RESPONSE PRIORITY CONTROL VERB (VENDOR-SPECIFIC)

	Verb ID	Payload [7:0]	Response[31:0]
Get	F8Eh	00h	Bits [31:0] in the table below
Set	78Eh	Bits [7:0] in the table below	00000000h

Bit	Bitfield Name	RW	Default	Description
[31:5]	Rsvd	R	0000000h	Reserved
[4:0]	Priority	RW	00h	Assigns a priority setting for queued Unsolicited Responses. Nodes with the lowest value have the highest priority, and so go to the front of the Unsolicited Response queue. Nodes with the same value for priority are queued on first-to-trigger basis. 00h = Highest priority ... 1Fh = Lowest priority

AUTO-MUTE CONTROL VERB (VENDOR-SPECIFIC)

	Verb ID	Payload [7:0]	Response[31:0]
Get	FB0h	00h	Bits [31:0] in the table below
Set	7B0h	Bits [7:0] in the table below	00000000h

Bit	Bitfield Name	RW	Default	Description
[31:1]	Rsvd	R	0000000h	Reserved
[0]	PD_AUTOMUTE	RW	0	Controls the WM8850 automute behavior when there is nothing plugged into Port-E: 0 = Automute disabled 1 = Automute enabled Note: When PD_AUTOMUTE=1 and Presence Detect (bit 31 in verb F09h)=1 the WM8850 will replace the samples in the stream with zeros

PORT-B PIN COMPLEX WIDGET (NID = 0DH)
AMPLIFIER GAIN/MUTE VERB

	Verb ID	Payload [15:0]	Response[31:0]
Get	Bh	2000h	Bits [31:0] in the response table below – applies to the left channel only
Get	Bh	0000h	Bits [31:0] in the response table below – applies to the right channel only
Set	3h	Bits [15:0] in the set table below	00000000h

Response Table:

Bit	Bitfield Name	RW	Default	Description
[31:8]	Rsvd	R	000000h	Reserved
[7]	Amplifier Mute	R	0	Mute not supported
[6:0]	Amplifier Gain	R	00h	Shows the amplifier gain setting (step number) for the selected channel. The actual gain applied is determined by the <i>Input Amplifier Capabilities Parameter</i> in the AFG (NID = 01h), and is shown below for convenience: 00h = 0dB 01h = +10dB 02h = +20dB 03h = +30dB

Set Table:

Bit	Bitfield Name	RW	Default	Description
[15]	Set Output Amp	R	0	Not applicable to this widget
[14]	Set Input Amp	W	1	Indicates that the programming refers to the input amplifier on this widget
[13]	Set Left Amp	W	1	0 = Left channel amplifier does not accept the values in <i>Mute</i> or <i>Gain</i> fields 1 = Left channel amplifier does accept the values in the <i>Mute</i> and <i>Gain</i> fields
[12]	Set Right Amp	W	1	0 = Right channel amplifier does not accept the values in <i>Mute</i> or <i>Gain</i> fields 1 = Right channel amplifier does accept the values in the <i>Mute</i> and <i>Gain</i> fields
[11:8]	Index	R	0h	Not applicable to this widget
[7]	Mute	R	0	Mute not supported
[6:0]	Gain	W	0h	Step number of the gain – see <i>Amplifier Gain</i> in response table above for details of actual gain values Note: Port-B amplifier implements Mic-Boost. The gain setting is always applied to both left and right channels when either (or both) the <i>Set Left Amp</i> or <i>Set Right Amp</i> registers are set. Dedicated boost settings for each channel are not supported.

GET PARAMETER VERB

	Verb ID	Payload [7:0]	Response[31:0]
Get	F00h	Parameter ID (PID)	Parameter Value

Audio Widget Capabilities Parameter (PID = 09h)

Bit	Bitfield Name	RW	Default	Description
[31:24]	Rsvd	R	00h	Reserved
[23:20]	Type	R	4h	Indicates that this is a Pin Complex Widget
[19:16]	Delay	R	0h	Latency not reported
[15:12]	Rsvd	R	0h	Reserved
[11]	L-R Swap	R	0	Left/Right swap capability not supported
[10]	PowerCntrl	R	0	Indicates that the <i>Power State Verb</i> is not supported in this widget
[9]	Digital	R	0	Indicates that this widget is translating analogue data
[8]	Conn List	R	0	Indicates that a connection list is not present
[7]	Unsol Capable	R	1	Widget supports Unsolicited Responses
[6]	ProcWidget	R	0	Widget does not have processing capabilities
[5]	Stripe	R	0	Widget does not support striping
[4]	Format Override	R	0	Widget does not override the format defined for the AFG
[3]	Amp Parameter Override	R	0	The AFG amplifier parameters are used for this widget
[2]	Out Amp Present	R	0	Output amplifier not present in this widget
[1]	In Amp Present	R	1	Input amplifier is present in this widget
[0]	Stereo	R	1	Indicates that this is a stereo widget

Pin Capabilities Parameter (PID = 0Ch)

Bit	Bitfield Name	RW	Default	Description
[31:17]	Rsvd	R	0000h	Reserved
[16]	EAPD Capable	R	0	Widget does not support an EAPD pin
[15:8]	VRef Control	R	17h	Indicates that the MICBIAS pin supports the following voltage levels: <ul style="list-style-type: none"> • Hi-Z • Ground • AVDD1 * 50% • AVDD1 * 80%
[7]	Rsvd	R	0	Reserved
[6]	Balanced I/O Pins	R	1	Indicates that this widget has balanced pins
[5]	Input Capable	R	1	Indicates that this widget is input capable
[4]	Output Capable	R	0	Indicates that this widget is not output capable
[3]	Headphone Drive Capable	R	0	Not applicable as this in an input port
[2]	Presence Detect Capable	R	1	Indicates that this Widget can perform presence detection
[1]	Trigger Required	R	1	Indicates that impedance measurement uses the <i>Execute</i> command that is part of the <i>Pin Sense Verb</i>
[0]	Impedance Sense Capable	R	1	Impedance measurement supported

PIN WIDGET CONTROL VERB

	Verb ID	Payload [7:0]	Response[31:0]
Get	F07h	00h	Bits [31:0] in the table below
Set	707h	Bits [7:0] in the table below	00000000h

Bit	Bitfield Name	RW	Default	Description
[31:8]	Rsvd	R	000000h	Reserved
[7]	H-Phn Enable	R	0	Not applicable as this in an input port
[6]	Out Enable	R	0	Not applicable as this in an input port
[5]	In Enable	RW	1	Controls the input path: 0 = Input path is disabled 1 = Input path is enabled
[4:3]	Rsvd	R	0	Reserved
[2:0]	VRefEn	RW	0h	MICBIAS control: 0h = Hi-Z 1h = AVDD1 * 50% 2h = Ground (0V) 3h = Reserved 4h = AVDD1 * 80% 5h-7h = Reserved Note: If VRefEn is set to a reserved value, the value programmed will be 0h (Hi-Z) to avoid any potential damage to external components

UNSOLICITED RESPONSE VERB

	Verb ID	Payload [7:0]	Response[31:0]
Get	F08h	00h	Bits [31:0] in the table below
Set	708h	Bits [7:0] in the table below	00000000h

Bit	Bitfield Name	RW	Default	Description
[31:8]	Rsvd	R	000000h	Reserved
[7]	Enable	RW	0	0 = Unsolicited Responses disabled for this node 1 = Unsolicited Responses enabled for this node
[6]	Rsvd	R	0	Reserved
[5:0]	Tag	RW	0Dh	A software programmable tag value that is returned in the top six bits (31:26) of every Unsolicited Response from this node. The default for <i>Tag</i> is equal to the Node ID.

Note: The Unsolicited Response for the AFG node is defined in the "Unsolicited Responses" section.

PIN SENSE VERB

	Verb ID	Payload [7:0]	Response[31:0]
Get	F09h	00h	Bits [31:0] in the table below
Execute	709h	00h	00000000h

Bit	Bitfield Name	RW	Default	Description
[31]	Presence Detect	R	0	0 = nothing plugged into Port-B 1 = something plugged into Port-B
[30:0]	Impedance Sense	R	7FFFFFFFh	Impedance sense value: 7FFFFFFFh = measurement not ready

EAPD/BTL VERB

	Verb ID	Payload [7:0]	Response[31:0]
Get	F0Ch	00h	Bits [31:0] in the table below
Set	70Ch	Bits [7:0] in the table below	00000000h

Bit	Bitfield Name	RW	Default	Description
[31:1]	Rsvd	R	000000h	Reserved
[0]	BTL	RW	1	Controls the configuration of the input pins on Port-B: 0 = Single-ended mode 1 = BTL (balanced) mode

CONFIGURATION DEFAULT VERB

	Verb ID	Payload [7:0]	Response[31:0]
Get	F1Ch	00h	Bits [31:0] in the table below
Set1	71Ch	Bits [7:0] in the table below	00000000h
Set2	71Dh	Bits [15:8] in the table below	00000000h
Set3	71Eh	Bits [23:16] in the table below	00000000h
Set4	71Fh	Bits [31:24] in the table below	00000000h

Bit	Bitfield Name	RW	Default	Description
[31:30]	Port Connectivity	RW	0h	Indicates the external connectivity: 0h = Jack 1h = No physical connection 2h = A fixed function device 3h = both a jack and an internal device are connected
[29:28]	Location[5:4]	RW	0h	Gross physical location of the device connected to Port-B: 0h = External on primary chassis 1h = Internal 2h = Separate chassis 3h = Other
[27:24]	Location[3:0]	RW	2h	Geometric location of the device connected to Port-B: 0h = Not applicable 1h = Rear 2h = Front 3h = Left 4h = Right 5h = Top 6h = Bottom 7h = Special 8h = Special 9h = Special Ah-Fh = Reserved

Bit	Bitfield Name	RW	Default	Description
[23:20]	Default Device	RW	Ah	Indicates the intended use of Port-B: 0h = Line out 1h = Speaker 2h = Headphone out 3h = CD 4h = S/PDIF out 5h = Digital other out 6h = Modem line side 7h = Modem handset side 8h = Line in 9h = AUX Ah = Mic in Bh = Telephony Ch = S/PDIF in Dh = Digital other in Eh = Reserved Fh = Other
[19:16]	Connection Type	RW	1h	Indicates the type of physical interface on Port-B: 0h = Unknown 1h = 3.5mm stereo/mono jack 2h = ¼" stereo/mono jack 3h = ATAPI internal 4h = RCA jack (for analogue audio or coaxial S/PDIF) 5h = Optical 6h = Other digital 7h = Other analogue 8h = Multi-channel analogue (DIN) 9h = XLR/Professional Ah = RJ-11 (modem) Bh = Combination Ch-Eh = Reserved Fh = Other
[15:12]	Colour	RW	9h	Indicates the colour of the physical jack on Port-B: 0h = Unknown 1h = Black 2h = Grey 3h = Blue 4h = Green 5h = Red 6h = Orange 7h = Yellow 8h = Purple 9h = Pink Ah-Dh = Reserved Eh = White Fh = Other

00h
01h
02h
03h
04h
05h
06h
07h
08h
09h
0Ah
0Bh
0Ch
0Dh
0Eh
0Fh
10h
11h
12h
13h
14h
15h
16h
17h

Bit	Bitfield Name	RW	Default	Description
[11:8]	Misc	RW	0h	Presence detection override: 0 = Presence detection indicated by <i>Pin Capabilities Parameter</i> 1 = Presence detection not supported. If the <i>Pin Capabilities Parameter</i> indicates that that presence detection is supported by the node, then this bit is used to override it to indicate the external circuitry is not capable of supporting presence detect All other values are reserved
[7:4]	Default Association	RW	Fh	Association number: 0h = Reserved 1h-Eh = Multi Channel or Single Pin Widget Fh = Single Pin Widget Only
[3:0]	Sequence	RW	0h	Sequence number used to define individual channel pairs within a stream. All values (0h-Fh) are available for use. Use a value of 0h for Single Pin Widget.

Note: The *Configuration Default Verb* is not reset to its default value during a reset from any source. The settings are only lost when digital power is removed from the WM8850. When digital power is restored, the System BIOS must restore the settings.

UNSOLICITED RESPONSE PRIORITY CONTROL VERB (VENDOR-SPECIFIC)

	Verb ID	Payload [7:0]	Response[31:0]
Get	F8Eh	00h	Bits [31:0] in the table below
Set	78Eh	Bits [7:0] in the table below	00000000h

Bit	Bitfield Name	RW	Default	Description
[31:5]	Rsvd	R	0000000h	Reserved
[4:0]	Priority	RW	00h	Assigns a priority setting for queued Unsolicited Responses. Nodes with the lowest value have the highest priority, and so go to the front of the Unsolicited Response queue. Nodes with the same value for priority are queued on first-to-trigger basis. 00h = Highest priority ... 1Fh = Lowest priority

DIFFERENTIAL VERB (VENDOR-SPECIFIC)

	Verb ID	Payload [7:0]	Response[31:0]
Get	FA3h	00h	Bits [31:0] in the table below
Set	7A3h	Bits [7:0] in the table below	00000000h

Bit	Bitfield Name	RW	Default	Description
[31:1]	Rsvd	R	0000000h	Reserved
[0]	Differential Mode	RW	1	Differential mode: 0 = Differential (Microphone) 1 = Pseudo-differential

AUTO-MUTE CONTROL VERB (VENDOR-SPECIFIC)

	Verb ID	Payload [7:0]	Response[31:0]
Get	FB0h	00h	Bits [31:0] in the table below
Set	7B0h	Bits [7:0] in the table below	00000000h

Bit	Bitfield Name	RW	Default	Description
[31:1]	Rsvd	R	0000000h	Reserved
[0]	PD_AUTOMUTE	RW	0	Controls the WM8850 automute behavior when there is nothing plugged into Port-B: 0 = Automute disabled 1 = Automute enabled Note: When <i>PD_AUTOMUTE=1</i> and <i>Presence Detect=1</i> the WM8850 will replace the samples in the stream with zeros

00h
01h
02h
03h
04h
05h
06h
07h
08h
09h
0Ah
0Bh
0Ch
0Dh
0Eh
0Fh
10h
11h
12h
13h
14h
15h
16h
17h

PORT-D PIN COMPLEX WIDGET (NID = 0EH)
AMPLIFIER GAIN/MUTE VERB

	Verb ID	Payload [15:0]	Response[31:0]
Get	Bh	2000h	Bits [31:0] in the response table below – applies to the left channel only
Get	Bh	0000h	Bits [31:0] in the response table below – applies to the right channel only
Set	3h	Bits [15:0] in the set table below	00000000h

Response Table:

Bit	Bitfield Name	RW	Default	Description
[31:8]	Rsvd	R	000000h	Reserved
[7]	Amplifier Mute	R	0	Shows the amplifier mute status of the selected channel: 0 = Normal 1 = Muted
[6:0]	Amplifier Gain	R	18h	Shows the amplifier gain setting (step number) for the selected channel. The actual gain applied is determined by the <i>Input Amplifier Capabilities Parameter</i> , and is shown below for convenience: 00h = -12dB 01h = -11.5dB ... 0.5dB steps 18h = 0dB ... 0.5dB steps 57h = +31.5dB 58h = +32dB

Set Table:

Bit	Bitfield Name	RW	Default	Description
[15]	Set Output Amp	W	0	Not applicable to this widget
[14]	Set Input Amp	W	1	Indicates that the programming refers to the input amplifier on this widget
[13]	Set Left Amp	W	1	0 = Left channel amplifier does not accept the values in <i>Mute</i> or <i>Gain</i> fields 1 = Left channel amplifier does accept the values in the <i>Mute</i> and <i>Gain</i> fields
[12]	Set Right Amp	W	1	0 = Right channel amplifier does not accept the values in <i>Mute</i> or <i>Gain</i> fields 1 = Right channel amplifier does accept the values in the <i>Mute</i> and <i>Gain</i> fields
[11:8]	Index	W	0h	Not applicable to this widget
[7]	Mute	W	0	0 = Normal operation 1 = Mute Note: When mute is applied to a channel, the data value is overwritten with all zeros.
[6:0]	Gain	W	18h	Step number of the gain – see <i>Amplifier Gain</i> in response table above for details of actual gain values

GET PARAMETER VERB

	Verb ID	Payload [7:0]	Response[31:0]
Get	F00h	Parameter ID (PID)	Parameter Value

Audio Widget Capabilities Parameter (PID = 09h)

Bit	Bitfield Name	RW	Default	Description
[31:24]	Rsvd	R	00h	Reserved
[23:20]	Type	R	4h	Indicates that this is a Pin Complex Widget
[19:16]	Delay	R	0h	Latency not reported
[15:12]	Rsvd	R	0h	Reserved
[11]	L-R Swap	R	0	Left/Right swap capability not supported
[10]	PowerCntrl	R	0	Indicates that the <i>Power State Verb</i> is not supported in this widget
[9]	Digital	R	1	Indicates that this widget is translating digital data
[8]	Conn List	R	0	Indicates that a connection list is not present
[7]	Unsol Capable	R	0	Widget does not support Unsolicited Responses
[6]	ProcWidget	R	0	Widget does not have processing capabilities
[5]	Stripe	R	0	Widget does not support striping
[4]	Format Override	R	0	Widget does not override the format defined for the AFG
[3]	Amp Parameter Override	R	1	The AFG amplifier parameters are overridden for this widget node
[2]	Out Amp Present	R	0	Output amplifier not present in this widget
[1]	In Amp Present	R	1	Input amplifier is present in this widget
[0]	Stereo	R	1	Indicates that this is a stereo widget

Pin Capabilities Parameter (PID = 0Ch)

Bit	Bitfield Name	RW	Default	Description
[31:17]	Rsvd	R	0000h	Reserved
[16]	EAPD Capable	R	0	Widget does not support an EAPD pin
[15:8]	VRef Control	R	00h	VRef not supported for Digital Inputs
[7]	Rsvd	R	0	Reserved
[6]	Balanced I/O Pins	R	0	Indicates that this widget does not have balanced pins
[5]	Input Capable	R	1	Indicates that this widget is input capable
[4]	Output Capable	R	0	Indicates that this widget is not output capable
[3]	Headphone Drive Capable	R	0	Not applicable as this in an input port
[2]	Presence Detect Capable	R	0	Presence detection not supported
[1]	Trigger Required	R	0	Impedance measurement not supported
[0]	Impedance Sense Capable	R	0	Impedance measurement not supported

Input Amplifier Capabilities Response Format (PID = 0Dh)

Bit	Bitfield Name	RW	Default	Description
[31]	Mute Capable	R	1	DMIC amplifiers are capable of hard-mute
[30:23]	Rsvd	R	0000h	Reserved
[22:16]	Step Size	R	01h	Gain step size is 0.5dB
[15]	Rsvd	R	0	Reserved
[14:8]	Num Steps	R	58h	Number of steps in gain range is 89 (-12dB to +32dB)
[7]	Rsvd	R	0	Reserved
[6:0]	Offset	R	18h	The step number that 0dB corresponds to is 18h

PIN WIDGET CONTROL VERB

	Verb ID	Payload [7:0]	Response[31:0]
Get	F07h	00h	Bits [31:0] in the table below
Set	707h	Bits [7:0] in the table below	00000000h

Bit	Bitfield Name	RW	Default	Description
[31:8]	Rsvd	R	000000h	Reserved
[7]	H-Phn Enable	R	0	Not applicable as this in an input port
[6]	Out Enable	R	0	Not applicable as this in an input port
[5]	In Enable	RW	1	Controls the input path: 0 = Input path is disabled 1 = Input path is enabled
[4:3]	Rsvd	R	0h	Reserved
[2:0]	VRefEn	R	0h	Selectable VRef not supported

CONFIGURATION DEFAULT VERB

	Verb ID	Payload [7:0]	Response[31:0]
Get	F1Ch	00h	Bits [31:0] in the table below
Set1	71Ch	Bits [7:0] in the table below	00000000h
Set2	71Dh	Bits [15:8] in the table below	00000000h
Set3	71Eh	Bits [23:16] in the table below	00000000h
Set4	71Fh	Bits [31:24] in the table below	00000000h

Bit	Bitfield Name	RW	Default	Description
[31:30]	Port Connectivity	RW	0h	Indicates the external connectivity: 0h = Jack 1h = No physical connection 2h = A fixed function device 3h = both a jack and an internal device are connected
[29:28]	Location[5:4]	RW	1h	Gross physical location of the device connected to Port-D: 0h = External on primary chassis 1h = Internal 2h = Separate chassis 3h = Other
[27:24]	Location[3:0]	RW	0h	Geometric location of the device connected to Port-D: 0h = Not applicable 1h = Rear 2h = Front 3h = Left 4h = Right 5h = Top 6h = Bottom 7h = Special 8h = Special 9h = Special Ah-Fh = Reserved

Bit	Bitfield Name	RW	Default	Description
[23:20]	Default Device	RW	Ah	Indicates the intended use of Port-D: 0h = Line out 1h = Speaker 2h = Headphone out 3h = CD 4h = S/PDIF out 5h = Digital other out 6h = Modem line side 7h = Modem handset side 8h = Line in 9h = AUX Ah = Mic in Bh = Telephony Ch = S/PDIF in Dh = Digital other in Eh = Reserved Fh = Other
[19:16]	Connection Type	RW	6h	Indicates the type of physical interface on Port-D: 0h = Unknown 1h = 3.5mm stereo/mono jack 2h = ¼" stereo/mono jack 3h = ATAPI internal 4h = RCA jack (for analogue audio or coaxial S/PDIF) 5h = Optical 6h = Other digital 7h = Other analogue 8h = Multi-channel analogue (DIN) 9h = XLR/Professional Ah = RJ-11 (modem) Bh = Combination Ch-Eh = Reserved Fh = Other
[15:12]	Colour	RW	0h	Indicates the colour of the physical jack on Port-D: 0h = Unknown 1h = Black 2h = Grey 3h = Blue 4h = Green 5h = Red 6h = Orange 7h = Yellow 8h = Purple 9h = Pink Ah-Dh = Reserved Eh = White Fh = Other

Bit	Bitfield Name	RW	Default	Description
[11:8]	Misc	RW	0h	Presence detection override: 0h = Presence detection indicated by <i>Pin Capabilities Parameter</i> 1h = Presence detection not supported. If the <i>Pin Capabilities Parameter</i> indicates that that presence detection is supported by the node, then this bit is used to override it to indicate the external circuitry is not capable of supporting presence detect All other values are reserved
[7:4]	Default Association	RW	Fh	Association number: 0h = Reserved 1h-Eh = Multi Channel or Single Pin Widget Fh = Single Pin Widget Only
[3:0]	Sequence	RW	0h	Sequence number used to define individual channel pairs within a stream. All values (0h-Fh) are available for use. Use a value of 0 for Single Pin Widget.

Note: The *Configuration Default Verb* is not reset to its default value during a reset from any source. The settings are only lost when digital power is removed from the WM8850. When digital power is restored, the System BIOS must restore the settings.

00h
01h
02h
03h
04h
05h
06h
07h
08h
09h
0Ah
0Bh
0Ch
0Dh
0Eh
0Fh
10h
11h
12h
13h
14h
15h
16h
17h

S/PDIF OUT PIN COMPLEX WIDGET (NID = 0FH)
GET PARAMETER VERB

	Verb ID	Payload [7:0]	Response[31:0]
Get	F00h	Parameter ID (PID)	Parameter Value

Audio Widget Capabilities Parameter (PID = 09h)

Bit	Bitfield Name	RW	Default	Description
[31:24]	Rsvd	R	00h	Reserved
[23:20]	Type	R	4h	Indicates that this is a Pin Complex Widget
[19:16]	Delay	R	0h	Latency not reported
[15:12]	Rsvd	R	0h	Reserved
[11]	L-R Swap	R	0	Left/Right swap capability not supported
[10]	PowerCntrl	R	0	Indicates that the <i>Power State Verb</i> is not supported in this widget
[9]	Digital	R	1	Indicates that this widget is translating digital data
[8]	Conn List	R	1	Indicates that a connection list is present
[7]	Unsol Capable	R	1	Widget supports Unsolicited Responses
[6]	ProcWidget	R	0	Widget does not have processing capabilities
[5]	Stripe	R	0	Widget does not support striping
[4]	Format Override	R	0	Widget does not override the format defined for the AFG
[3]	Amp Parameter Override	R	0	Not applicable as this widget does not have amplifier capabilities
[2]	Out Amp Present	R	0	Output amplifier not present in this widget
[1]	In Amp Present	R	0	Input amplifier is present in this widget
[0]	Stereo	R	1	Indicates that this is a stereo widget

Pin Capabilities Parameter (PID = 0Ch)

Bit	Bitfield Name	RW	Default	Description
[31:17]	Rsvd	R	0000h	Reserved
[16]	EAPD Capable	R	0	Widget does not support an EAPD pin
[15:8]	VRef Control	R	00h	VRef not supported for digital outputs
[7]	Rsvd	R	0	Reserved
[6]	Balanced I/O Pins	R	0	Indicates that this widget does not have balanced pins
[5]	Input Capable	R	0	Indicates that this widget is not input capable
[4]	Output Capable	R	1	Indicates that this widget is output capable
[3]	Headphone Drive Capable	R	0	Not applicable as this is an input port
[2]	Presence Detect Capable	R	1	Indicates that this widget can perform presence detection
[1]	Trigger Required	R	0	Impedance measurement not supported
[0]	Impedance Sense Capable	R	0	Impedance measurement not supported

Connection List Length Parameter (PID = 0Eh)

Bit	Bitfield Name	RW	Default	Description
[31:8]	Rsvd	R	000000h	Reserved
[7]	Long Form	R	0	Indicates that the connection list items are in short form
[6:0]	Connection List Length	R	01h	Indicates that there is 1 NID entry in the connection list

GET CONNECTION LIST ENTRY VERB

	Verb ID	Payload [7:0]	Response[31:0]
Get	F02h	00h	Bits [31:0] in the table below

Bit	Bitfield Name	RW	Default	Description
[31:24]	Conn List Entry 3	R	00h	Unused connection list entry
[23:16]	Conn List Entry 2	R	00h	Unused connection list entry
[15:8]	Conn List Entry 1	R	00h	Unused connection list entry
[7:0]	Conn List Entry 0	R	04h	Indicates that the S/PDIF Out Pin Widget connects to the S/PDIF Tx 1 Widget (NID = 04h)

PIN WIDGET CONTROL VERB

	Verb ID	Payload [7:0]	Response[31:0]
Get	F07h	00h	Bits [31:0] in the table below
Set	707h	Bits [7:0] in the table below	00000000h

Bit	Bitfield Name	RW	Default	Description
[31:8]	Rsvd	R	000000h	Reserved
[7]	H-Phn Enable	R	0	Not applicable for S/PDIF Out
[6]	Out Enable	RW	1	Controls the output path: 0 = Output path is disabled 1 = Output path is enabled Note: If S/PDIF Out sources the S/PDIF Tx 1 Widget and <i>OutEnable</i> =0, the S/PDIF signal is still transmitted, but the payload of the S/PDIF signal is filled with zeros. In this way, the <i>OutEnable</i> register acts as a S/PDIF Mute. When sourcing the S/PDIF TX 1 Widget, the user can have the S/PDIF Out pin drive 0 by setting <i>DigEn</i> (in the S/PDIF TX 1 Widget) to 0. Note: If S/PDIF Out sources the S/PDIF In widget and <i>OutEnable</i> =0, the S/PDIF Out pin drives zero. The <i>Digen</i> register has no context in this configuration, and is ignored.
[5]	In Enable	R	0	Not applicable for S/PDIF Out
[4:3]	Rsvd	R	0h	Reserved
[2:0]	VRefEn	RW	0h	Selectable VRef not supported

UNSOLICITED RESPONSE VERB

	Verb ID	Payload [7:0]	Response[31:0]
Get	F08h	00h	Bits [31:0] in the table below
Set	708h	Bits [7:0] in the table below	00000000h

Bit	Bitfield Name	RW	Default	Description
[31:8]	Rsvd	R	000000h	Reserved
[7]	Enable	RW	0	0 = Unsolicited Responses disabled for this node 1 = Unsolicited Responses enabled for this node
[6]	Rsvd	R	0	Reserved
[5:0]	Tag	RW	0Fh	A software programmable tag value that is returned in the top six bits (31:26) of every Unsolicited Response from this node. The default for <i>Tag</i> is equal to the Node ID.

Note: The Unsolicited Response for the AFG node is defined in the "Unsolicited Responses" section.

PIN SENSE VERB

	Verb ID	Payload [7:0]	Response[31:0]
Get	F09h	00h	Bits [31:0] in the table below

Bit	Bitfield Name	RW	Default	Description
[31]	Presence Detect	R	0	0 = nothing plugged into S/PDIF Out 1 = something plugged into S/PDIF Out
[30:0]	Impedance Sense	R	00000000h	Impedance sense not supported

CONFIGURATION DEFAULT VERB

	Verb ID	Payload [7:0]	Response[31:0]
Get	F1Ch	00h	Bits [31:0] in the table below
Set1	71Ch	Bits [7:0] in the table below	00000000h
Set2	71Dh	Bits [15:8] in the table below	00000000h
Set3	71Eh	Bits [23:16] in the table below	00000000h
Set4	71Fh	Bits [31:24] in the table below	00000000h

Bit	Bitfield Name	RW	Default	Description
[31:30]	Port Connectivity	RW	0h	Indicates the external connectivity: 0h = Jack 1h = No physical connection 2h = A fixed function device 3h = both a jack and an internal device are connected
[29:28]	Location[5:4]	RW	0h	Gross physical location of the device connected to S/PDIF Out: 0h = External on primary chassis 1h = Internal 2h = Separate chassis 3h = Other
[27:24]	Location[3:0]	RW	1h	Geometric location of the device connected to S/PDIF Out: 0h = Not applicable 1h = Rear 2h = Front 3h = Left 4h = Right 5h = Top 6h = Bottom 7h = Special 8h = Special 9h = Special Ah-Fh = Reserved

Bit	Bitfield Name	RW	Default	Description
[23:20]	Default Device	RW	4h	Indicates the intended use of S/PDIF Out: 0h = Line out 1h = Speaker 2h = Headphone out 3h = CD 4h = S/PDIF out 5h = Digital other out 6h = Modem line side 7h = Modem handset side 8h = Line in 9h = AUX Ah = Mic in Bh = Telephony Ch = S/PDIF in Dh = Digital other in Eh = Reserved Fh = Other
[19:16]	Connection Type	RW	5h	Indicates the type of physical interface on S/PDIF Out: 0h = Unknown 1h = 3.5mm stereo/mono jack 2h = ¼" stereo/mono jack 3h = ATAPI internal 4h = RCA jack (for analogue audio or coaxial S/PDIF) 5h = Optical 6h = Other digital 7h = Other analogue 8h = Multi-channel analogue (DIN) 9h = XLR/Professional Ah = RJ-11 (modem) Bh = Combination Ch-Eh = Reserved Fh = Other
[15:12]	Colour	RW	9h	Indicates the colour of the physical jack on S/PDIF Out: 0h = Unknown 1h = Black 2h = Grey 3h = Blue 4h = Green 5h = Red 6h = Orange 7h = Yellow 8h = Purple 9h = Pink Ah-Dh = Reserved Eh = White Fh = Other

Bit	Bitfield Name	RW	Default	Description
[11:8]	Misc	RW	1h	Presence detection override: 0 = Presence detection indicated by <i>Pin Capabilities Parameter</i> 1 = Presence detection not supported. If the <i>Pin Capabilities Parameter</i> indicates that that presence detection is supported by the node, then this bit is used to override it to indicate the external circuitry is not capable of supporting presence detect All other values are reserved
[7:4]	Default Association	RW	Fh	Association number: 0h = Reserved 1h-Eh = Multi Channel or Single Pin Widget Fh = Single Pin Widget Only
[3:0]	Sequence	RW	0h	Sequence number used to define individual channel pairs within a stream. All values (0h-Fh) are available for use. Use a value of 0 for Single Pin Widget.

Note: The *Configuration Default Verb* is not reset to its default value during a reset from any source. The settings are only lost when digital power is removed from the WM8850. When digital power is restored, the System BIOS must restore the settings.

INTERNAL PATH VERB (VENDOR-SPECIFIC)

	Verb ID	Payload [7:0]	Response[31:0]
Get	F73h	00h	Bits [31:0] in the table below
Set	773h	Bits [7:0] in the table below	00000000h

Bit	Bitfield Name	RW	Default	Description
[31:1]	Rsvd	R	0000000h	Reserved
[7:0]	Path Sel	RW	4h	Selects source of S/PDIF Out node: 04h = S/PDIF Tx 1 10h = S/PDIF In Note: This verb can overwrite the path setup by the connection list

UNSOLICITED RESPONSE PRIORITY CONTROL VERB (VENDOR-SPECIFIC)

	Verb ID	Payload [7:0]	Response[31:0]
Get	F8Eh	00h	Bits [31:0] in the table below
Set	78Eh	Bits [7:0] in the table below	00000000h

Bit	Bitfield Name	RW	Default	Description
[31:5]	Rsvd	R	0000000h	Reserved
[4:0]	Priority	RW	00h	Assigns a priority setting for queued Unsolicited Responses. Nodes with the lowest value have the highest priority, and so go to the front of the Unsolicited Response queue. Nodes with the same value for priority are queued on first-to-trigger basis. 00h = Highest priority ... 1Fh = Lowest priority

S/PDIF IN PIN COMPLEX WIDGET (NID = 10H)
GET PARAMETER VERB

	Verb ID	Payload [7:0]	Response[31:0]
Get	F00h	Parameter ID (PID)	Parameter Value

Audio Widget Capabilities Parameter (PID = 09h)

Bit	Bitfield Name	RW	Default	Description
[31:24]	Rsvd	R	00h	Reserved
[23:20]	Type	R	4h	Indicates that this is a Pin Complex Widget
[19:16]	Delay	R	0h	Latency not reported
[15:12]	Rsvd	R	0h	Reserved
[11]	L-R Swap	R	0	Left/Right swap capability not supported
[10]	PowerCntrl	R	0	Indicates that the <i>Power State Verb</i> is not supported in this widget
[9]	Digital	R	1	Indicates that this widget is translating digital data
[8]	Conn List	R	0	Indicates that a connection list is not present
[7]	Unsol Capable	R	1	Widget supports Unsolicited Responses
[6]	ProcWidget	R	0	Widget does not have processing capabilities
[5]	Stripe	R	0	Widget does not support striping
[4]	Format Override	R	0	Widget does not override the format defined for the AFG
[3]	Amp Parameter Override	R	0	Not applicable as this widget does not have amplifier capabilities
[2]	Out Amp Present	R	0	Output amplifier not present in this widget
[1]	In Amp Present	R	0	Input amplifier is present in this widget
[0]	Stereo	R	1	Indicates that this is a stereo widget

Pin Capabilities Parameter (PID = 0Ch)

Bit	Bitfield Name	RW	Default	Description
[31:17]	Rsvd	R	0000h	Reserved
[16]	EAPD Capable	R	0	Widget does not support an EAPD pin
[15:8]	VRef Control	R	00h	VRef not supported for digital outputs
[7]	Rsvd	R	0	Reserved
[6]	Balanced I/O Pins	R	0	Indicates that this widget does not have balanced pins
[5]	Input Capable	R	1	Indicates that this widget is input capable
[4]	Output Capable	R	0	Indicates that this widget is not output capable
[3]	Headphone Drive Capable	R	0	Not applicable as this is an input port
[2]	Presence Detect Capable	R	0	Indicates if this widget can perform presence detection Note: Value is set based on <i>PD Config</i> register in <i>S/PDIF In Control Verb</i>
[1]	Trigger Required	R	0	Impedance measurement not supported
[0]	Impedance Sense Capable	R	0	Impedance measurement not supported

PIN WIDGET CONTROL VERB

	Verb ID	Payload [7:0]	Response[31:0]
Get	F07h	00h	Bits [31:0] in the table below
Set	707h	Bits [7:0] in the table below	00000000h

Bit	Bitfield Name	RW	Default	Description
[31:8]	Rsvd	R	000000h	Reserved
[7]	H-Phn Enable	R	0	Not applicable for S/PDIF In
[6]	Out Enable	R	0	Not applicable for S/PDIF In
[5]	In Enable	RW	1	Controls the input path: 0 = Input path is disabled 1 = Input path is enabled
[4:3]	Rsvd	R	0h	Reserved
[2:0]	VRefEn	R	0h	Selectable VRef not supported

UNSOLICITED RESPONSE VERB

	Verb ID	Payload [7:0]	Response[31:0]
Get	F08h	00h	Bits [31:0] in the table below
Set	708h	Bits [7:0] in the table below	00000000h

Bit	Bitfield Name	RW	Default	Description
[31:8]	Rsvd	R	000000h	Reserved
[7]	Enable	RW	0	0 = Unsolicited Responses disabled for this node 1 = Unsolicited Responses enabled for this node
[6]	Rsvd	R	0	Reserved
[5:0]	Tag	RW	10h	A software programmable tag value that is returned in the top six bits (31:26) of every Unsolicited Response from this node. The default for <i>Tag</i> is equal to the Node ID.

Note: The Unsolicited Response for the AFG node is defined in the "Unsolicited Responses" section.

PIN SENSE VERB

	Verb ID	Payload [7:0]	Response[31:0]
Get	F09h	00h	Bits [31:0] in the table below
Execute	709h	00h	00000000h

Bit	Bitfield Name	RW	Default	Description
[31]	Presence Detect	R	0	The value reported here reflects the lock status of the S/PDIF receiver: 0 = S/PDIF Rx is unlocked 1 = S/PDIF Rx is locked
[30:0]	Impedance Sense	R	00000000h	Impedance sense not supported

CONFIGURATION DEFAULT VERB

	Verb ID	Payload [7:0]	Response[31:0]
Get	F1Ch	00h	Bits [31:0] in the table below
Set1	71Ch	Bits [7:0] in the table below	00000000h
Set2	71Dh	Bits [15:8] in the table below	00000000h
Set3	71Eh	Bits [23:16] in the table below	00000000h
Set4	71Fh	Bits [31:24] in the table below	00000000h

Bit	Bitfield Name	RW	Default	Description
[31:30]	Port Connectivity	RW	0h	Indicates the external connectivity: 0h = Jack 1h = No physical connection 2h = A fixed function device 3h = both a jack and an internal device are connected
[29:28]	Location[5:4]	RW	0h	Gross physical location of the device connected to SPDIF_IN: 0h = External on primary chassis 1h = Internal 2h = Separate chassis 3h = Other
[27:24]	Location[3:0]	RW	1h	Geometric location of the device connected to SPDIF_IN: 0h = Not applicable 1h = Rear 2h = Front 3h = Left 4h = Right 5h = Top 6h = Bottom 7h = Special 8h = Special 9h = Special Ah-Fh = Reserved
[23:20]	Default Device	RW	Ch	Indicates the intended use of SPDIF_IN: 0h = Line out 1h = Speaker 2h = Headphone out 3h = CD 4h = S/PDIF out 5h = Digital other out 6h = Modem line side 7h = Modem handset side 8h = Line in 9h = AUX Ah = Mic in Bh = Telephony Ch = S/PDIF in Dh = Digital other in Eh = Reserved Fh = Other

Bit	Bitfield Name	RW	Default	Description
[19:16]	Connection Type	RW	5h	Indicates the type of physical interface on SPDIF_IN: 0h = Unknown 1h = 3.5mm stereo/mono jack 2h = ¼" stereo/mono jack 3h = ATAPI internal 4h = RCA jack (for analogue audio or coaxial S/PDIF) 5h = Optical 6h = Other digital 7h = Other analogue 8h = Multi-channel analogue (DIN) 9h = XLR/Professional Ah = RJ-11 (modem) Bh = Combination Ch-Eh = Reserved Fh = Other
[15:12]	Colour	RW	2h	Indicates the colour of the physical jack on SPDIF_IN: 0h = Unknown 1h = Black 2h = Grey 3h = Blue 4h = Green 5h = Red 6h = Orange 7h = Yellow 8h = Purple 9h = Pink Ah-Dh = Reserved Eh = White Fh = Other
[11:8]	Misc	RW	0h	Presence detection override: 0 = Presence detection indicated by <i>Pin Capabilities Parameter</i> 1 = Presence detection not supported. If the <i>Pin Capabilities Parameter</i> indicates that that presence detection is supported by the node, then this bit is used to override it to indicate the external circuitry is not capable of supporting presence detect All other values are reserved
[7:4]	Default Association	RW	Fh	Association number: 0h = Reserved 1h-Eh = Multi Channel or Single Pin Widget Fh = Single Pin Widget Only
[3:0]	Sequence	RW	0h	Sequence number used to define individual channel pairs within a stream. All values (0h-Fh) are available for use. Use a value of 0h for Single Pin Widget.

Note: The *Configuration Default Verb* is not reset to its default value during a reset from any source. The settings are only lost when digital power is removed from the WM8850. When digital power is restored, the System BIOS must restore the settings.

UNSOLICITED RESPONSE PRIORITY CONTROL VERB (VENDOR-SPECIFIC)

	Verb ID	Payload [7:0]	Response[31:0]
Get	F8Eh	00h	Bits [31:0] in the table below
Set	78Eh	Bits [7:0] in the table below	00000000h

Bit	Bitfield Name	RW	Default	Description
[31:5]	Rsvd	R	0000000h	Reserved
[4:0]	Priority	RW	00h	Assigns a priority setting for queued Unsolicited Responses. Nodes with the lowest value have the highest priority, and so go to the front of the Unsolicited Response queue. Nodes with the same value for priority are queued on first-to-trigger basis. 00h = Highest priority ... 1Fh = Lowest priority

GET S/PDIF IN STATUS VERB (VENDOR-SPECIFIC)

	Verb ID	Payload [7:0]	Response[31:0]
Get	FA0h	00h	Bits [31:0] in the table below

Bit	Bitfield Name	RW	Default	Description
[31:4]	Rsvd	R	0000000h	Reserved
[3:1]	RATE	R	7h	Recovered sample rate: 0h = Reserved 1h = Reserved 2h = 96 kHz 3h = 88.2 kHz 4h = 48 kHz 5h = 44.1 kHz 6h = 32 kHz 7h = Sample rate not detected
[0]	LOCK	R	0	S/PDIF Rx lock flag: 0 = Unlocked 1 = Locked

S/PDIF IN CONTROL VERB (VENDOR-SPECIFIC)

	Verb ID	Payload [7:0]	Response[31:0]
Get	FA1h	00h	Bits [31:0] in the table below
Set	7A1h	Bits [7:0] in the table below	00000000h

Bit	Bitfield Name	RW	Default	Description
[31:4]	Rsvd	R	0000000	Reserved
[3]	Unlock Ctrl	RW	0	Configures how the SPDIF Rx audio path handles an unlock/relock condition: 0 = push method, where recovered sample rate is updated immediately and a re-write of the stream ID is not required to re-start data transmission 1 = controlled method, where the recovered sample rate is updated after the stream ID has been set to 0. R e-writing the stream ID to a non-zero value re-starts data transmission.
[2]	PD Config	RW	0	Configures the <i>Presence Detect Capable</i> parameter: 0 = parameter set to 0 1 = parameter set to 1 When set to 0, Presence Detect reporting via the <i>Pin Sense Verb</i> is disabled, as is Unsolicited Response generation from the <i>SF_PD</i> flag from the S/PDIF In node.
[1]	CMOS Thres	RW	0	Selects the logic threshold levels when in CMOS Mode: 0 = 30% / 70% thresholds 1 = 20% / 40% thresholds
[0]	Pin Mode Sel	RW	0	The SPDIF_IN pin supports both CMOS-compatible inputs and Comparator Inputs compatible with 500mVpp AC coupled consumer S/PDIF signals as defined in IEC60958-3. <i>Pin Mode Sel</i> selects between these options: 0 = CMOS Mode 1 = Comparator Mode

PORT-A PIN COMPLEX WIDGET (NID = 11H)
GET PARAMETER VERB

	Verb ID	Payload [7:0]	Response[31:0]
Get	F00h	Parameter ID (PID)	Parameter Value

Audio Widget Capabilities Parameter (PID = 09h)

Bit	Bitfield Name	RW	Default	Description
[31:24]	Rsvd	R	00h	Reserved
[23:20]	Type	R	4h	Indicates that this is a Pin Complex Widget
[19:16]	Delay	R	0h	Latency not reported
[15:12]	Rsvd	R	0h	Reserved
[11]	L-R Swap	R	0	Left/Right swap capability not supported
[10]	PowerCntrl	R	0	Indicates that the <i>Power State Verb</i> is not supported in this widget
[9]	Digital	R	0	Indicates that this widget is translating analogue data
[8]	Conn List	R	1	Indicates that a connection list is present
[7]	Unsol Capable	R	1	Widget supports Unsolicited Responses
[6]	ProcWidget	R	0	Widget does not have processing capabilities
[5]	Stripe	R	0	Widget does not support striping
[4]	Format Override	R	0	Widget does not override the format defined for the AFG
[3]	Amp Parameter Override	R	0	Not applicable as this widget does not have amplifier capabilities
[2]	Out Amp Present	R	0	Output amplifier not present in this widget
[1]	In Amp Present	R	0	Input amplifier not present in this widget
[0]	Stereo	R	1	Indicates that this is a stereo widget

Pin Capabilities Parameter (PID = 0Ch)

Bit	Bitfield Name	RW	Default	Description
[31:17]	Rsvd	R	0000h	Reserved
[16]	EAPD Capable	R	0	Widget does not support an EAPD pin
[15:8]	VRef Control	R	00h	VRef not supported for digital outputs
[7]	Rsvd	R	0	Reserved
[6]	Balanced I/O Pins	R	0	Indicates that this widget does not have balanced pins
[5]	Input Capable	R	0	Indicates that this widget is not input capable
[4]	Output Capable	R	1	Indicates that this widget is output capable
[3]	Headphone Drive Capable	R	1	Indicates that this widget has a headphone driver
[2]	Presence Detect Capable	R	1	Indicates that this widget can perform presence detection
[1]	Trigger Required	R	0	Impedance measurement not supported
[0]	Impedance Sense Capable	R	0	Impedance measurement not supported

Connection List Length Parameter (PID = 0Eh)

Bit	Bitfield Name	RW	Default	Description
[31:8]	Rsvd	R	000000h	Reserved
[7]	Long Form	R	0	Indicates that the connection list items are in short form
[6:0]	Connection List Length	R	01h	Indicates that there is 1 NID entry in the connection list

GET CONNECTION LIST ENTRY VERB

	Verb ID	Payload [7:0]	Response[31:0]
Get	F02h	00h	Bits [31:0] in the table below

Bit	Bitfield Name	RW	Default	Description
[31:24]	Conn List Entry 3	R	00h	Unused connection list entry
[23:16]	Conn List Entry 2	R	00h	Unused connection list entry
[15:8]	Conn List Entry 1	R	00h	Unused connection list entry
[7:0]	Conn List Entry 0	R	06h	Indicates that the Port-A Pin Widget connects to the DAC1 Widget (NID = 06h)

PIN WIDGET CONTROL VERB

	Verb ID	Payload [7:0]	Response[31:0]
Get	F07h	00h	Bits [31:0] in the table below
Set	707h	Bits [7:0] in the table below	00000000h

Bit	Bitfield Name	RW	Default	Description
[31:8]	Rsvd	R	000000h	Reserved
[7]	H-Phn Enable	RW	0h	Headphone amplifier enable: 0 = Disable 1 = Enable Note: If the <i>H-Phn Enable</i> register is set to 1, the actual gain setting applied has an offset of -8dB from the setting configured by the <i>Gain</i> register in the DAC1 <i>Amplifier Gain/Mute Verb</i> .
[6]	Out Enable	RW	1	Controls the output path: 0 = Output path is disabled 1 = Output path is enabled
[5]	In Enable	R	0	Not applicable for Port-A
[4:3]	Rsvd	R	0h	Reserved
[2:0]	VRefEn	R	0h	Selectable VRef not supported

UNSOLICITED RESPONSE VERB

	Verb ID	Payload [7:0]	Response[31:0]
Get	F08h	00h	Bits [31:0] in the table below
Set	708h	Bits [7:0] in the table below	00000000h

Bit	Bitfield Name	RW	Default	Description
[31:8]	Rsvd	R	000000h	Reserved
[7]	Enable	RW	0	0 = Unsolicited Responses disabled for this node 1 = Unsolicited Responses enabled for this node
[6]	Rsvd	R	0	Reserved
[5:0]	Tag	RW	11h	A software programmable tag value that is returned in the top six bits (31:26) of every Unsolicited Response from this node. The default for <i>Tag</i> is equal to the Node ID.

Note: The Unsolicited Response for the AFG node is defined in the "Unsolicited Responses" section.

PIN SENSE VERB

	Verb ID	Payload [7:0]	Response[31:0]
Get	F09h	00h	Bits [31:0] in the table below

Bit	Bitfield Name	RW	Default	Description
[31]	Presence Detect	R	0	0 = nothing plugged into Port-A 1 = something plugged into Port-A
[30:0]	Impedance Sense	R	00000000h	Impedance sense not supported

CONFIGURATION DEFAULT VERB

	Verb ID	Payload [7:0]	Response[31:0]
Get	F1Ch	00h	Bits [31:0] in the table below
Set1	71Ch	Bits [7:0] in the table below	00000000h
Set2	71Dh	Bits [15:8] in the table below	00000000h
Set3	71Eh	Bits [23:16] in the table below	00000000h
Set4	71Fh	Bits [31:24] in the table below	00000000h

Bit	Bitfield Name	RW	Default	Description
[31:30]	Port Connectivity	RW	0h	Indicates the external connectivity: 0h = Jack 1h = No physical connection 2h = A fixed function device 3h = both a jack and an internal device are connected
[29:28]	Location[5:4]	RW	0h	Gross physical location of the device connected to Port-A: 0h = External on primary chassis 1h = Internal 2h = Separate chassis 3h = Other
[27:24]	Location[3:0]	RW	1h	Geometric location of the device connected to Port-A: 0h = Not applicable 1h = Rear 2h = Front 3h = Left 4h = Right 5h = Top 6h = Bottom 7h = Special 8h = Special 9h = Special Ah-Fh = Reserved

Bit	Bitfield Name	RW	Default	Description
[23:20]	Default Device	RW	0h	Indicates the intended use of Port-A: 0h = Line out 1h = Speaker 2h = Headphone out 3h = CD 4h = S/PDIF out 5h = Digital other out 6h = Modem line side 7h = Modem handset side 8h = Line in 9h = AUX Ah = Mic in Bh = Telephony Ch = S/PDIF in Dh = Digital other in Eh = Reserved Fh = Other
[19:16]	Connection Type	RW	1h	Indicates the type of physical interface on Port-A: 0h = Unknown 1h = 3.5mm stereo/mono jack 2h = ¼" stereo/mono jack 3h = ATAPI internal 4h = RCA jack (for analogue audio or coaxial S/PDIF) 5h = Optical 6h = Other digital 7h = Other analogue 8h = Multi-channel analogue (DIN) 9h = XLR/Professional Ah = RJ-11 (modem) Bh = Combination Ch-Eh = Reserved Fh = Other
[15:12]	Colour	RW	4h	Indicates the colour of the physical jack on Port-A: 0h = Unknown 1h = Black 2h = Grey 3h = Blue 4h = Green 5h = Red 6h = Orange 7h = Yellow 8h = Purple 9h = Pink Ah-Dh = Reserved Eh = White Fh = Other

Bit	Bitfield Name	RW	Default	Description
[11:8]	Misc	RW	0h	Presence detection override: 0 = Presence detection indicated by <i>Pin Capabilities Parameter</i> 1 = Presence detection not supported. If the <i>Pin Capabilities Parameter</i> indicates that that presence detection is supported by the node, then this bit is used to override it to indicate the external circuitry is not capable of supporting presence detect All other values are reserved
[7:4]	Default Association	RW	2h	Association number: 0h = Reserved 1h-Eh = Multi Channel or Single Pin Widget Fh = Single Pin Widget Only
[3:0]	Sequence	RW	0h	Sequence number used to define individual channel pairs within a stream. All values (0h-Fh) are available for use. Use a value of 0 for Single Pin Widget.

Note: The *Configuration Default Verb* is not reset to its default value during a reset from any source. The settings are only lost when digital power is removed from the WM8850. When digital power is restored, the System BIOS must restore the settings.

UNSOLICITED RESPONSE PRIORITY CONTROL VERB (VENDOR-SPECIFIC)

	Verb ID	Payload [7:0]	Response[31:0]
Get	F8Eh	00h	Bits [31:0] in the table below
Set	78Eh	Bits [7:0] in the table below	00000000h

Bit	Bitfield Name	RW	Default	Description
[31:5]	Rsvd	R	0000000h	Reserved
[4:0]	Priority	RW	00h	Assigns a priority setting for queued Unsolicited Responses. Nodes with the lowest value have the highest priority, and so go to the front of the Unsolicited Response queue. Nodes with the same value for priority are queued on first-to-trigger basis. 00h = Highest priority ... 1Fh = Lowest priority

PORT-G PIN COMPLEX WIDGET (NID = 12H)
GET PARAMETER VERB

	Verb ID	Payload [7:0]	Response[31:0]
Get	F00h	Parameter ID (PID)	Parameter Value

Audio Widget Capabilities Parameter (PID = 09h)

Bit	Bitfield Name	RW	Default	Description
[31:24]	Rsvd	R	00h	Reserved
[23:20]	Type	R	4h	Indicates that this is a Pin Complex Widget
[19:16]	Delay	R	0h	Latency not reported
[15:12]	Rsvd	R	0h	Reserved
[11]	L-R Swap	R	0	Left/Right swap capability not supported
[10]	PowerCntrl	R	0	Indicates that the <i>Power State Verb</i> is not supported in this widget
[9]	Digital	R	0	Indicates that this widget is translating analogue data
[8]	Conn List	R	1	Indicates that a connection list is present
[7]	Unsol Capable	R	1	Widget supports Unsolicited Responses
[6]	ProcWidget	R	0	Widget does not have processing capabilities
[5]	Stripe	R	0	Widget does not support striping
[4]	Format Override	R	0	Widget does not override the format defined for the AFG
[3]	Amp Parameter Override	R	0	Not applicable as this widget does not have amplifier capabilities
[2]	Out Amp Present	R	0	Output amplifier not present in this widget
[1]	In Amp Present	R	0	Input amplifier not present in this widget
[0]	Stereo	R	1	Indicates that this is a stereo widget

Pin Capabilities Parameter (PID = 0Ch)

Bit	Bitfield Name	RW	Default	Description
[31:17]	Rsvd	R	0000h	Reserved
[16]	EAPD Capable	R	0	Widget does not support an EAPD pin
[15:8]	VRef Control	R	00h	VRef not supported for digital outputs
[7]	Rsvd	R	0	Reserved
[6]	Balanced I/O Pins	R	0	Indicates that this widget does not have balanced pins
[5]	Input Capable	R	0	Indicates that this widget is not input capable
[4]	Output Capable	R	1	Indicates that this widget is output capable
[3]	Headphone Drive Capable	R	0	Indicates that this widget does not have a headphone driver
[2]	Presence Detect Capable	R	1	Indicates that this widget can perform presence detection
[1]	Trigger Required	R	0	Impedance measurement not supported
[0]	Impedance Sense Capable	R	0	Impedance measurement not supported

Connection List Length Parameter (PID = 0Eh)

Bit	Bitfield Name	RW	Default	Description
[31:8]	Rsvd	R	000000h	Reserved
[7]	Long Form	R	0	Indicates that the connection list items are in short form
[6:0]	Connection List Length	R	01h	Indicates that there is 1 NID entry in the connection list

GET CONNECTION LIST ENTRY VERB

	Verb ID	Payload [7:0]	Response[31:0]
Get	F02h	00h	Bits [31:0] in the table below

Bit	Bitfield Name	RW	Default	Description
[31:24]	Conn List Entry 3	R	00h	Unused connection list entry
[23:16]	Conn List Entry 2	R	00h	Unused connection list entry
[15:8]	Conn List Entry 1	R	00h	Unused connection list entry
[7:0]	Conn List Entry 0	R	07h	Indicates that the Port-G Pin Widget connects to the DAC2 Widget (NID = 07h)

PIN WIDGET CONTROL VERB

	Verb ID	Payload [7:0]	Response[31:0]
Get	F07h	00h	Bits [31:0] in the table below
Set	707h	Bits [7:0] in the table below	00000000h

Bit	Bitfield Name	RW	Default	Description
[31:8]	Rsvd	R	0000000h	Reserved
[7]	H-Phn Enable	R	0	Not applicable for Port-G
[6]	Out Enable	RW	1	Controls the output path: 0 = Output path is disabled 1 = Output path is enabled
[5]	In Enable	R	0	Not applicable for Port-G
[4:3]	Rsvd	R	0h	Reserved
[2:0]	VRefEn	R	0h	Selectable VRef not supported

UNSOLICITED RESPONSE VERB

	Verb ID	Payload [7:0]	Response[31:0]
Get	F08h	00h	Bits [31:0] in the table below
Set	708h	Bits [7:0] in the table below	00000000h

Bit	Bitfield Name	RW	Default	Description
[31:8]	Rsvd	R	0000000h	Reserved
[7]	Enable	RW	0	0 = Unsolicited Responses disabled for this node 1 = Unsolicited Responses enabled for this node
[6]	Rsvd	R	0	Reserved
[5:0]	Tag	RW	12h	A software programmable tag value that is returned in the top six bits (31:26) of every Unsolicited Response from this node. The default for <i>Tag</i> is equal to the Node ID.

Note: The Unsolicited Response for the AFG node is defined in the "Unsolicited Responses" section.

PIN SENSE VERB

	Verb ID	Payload [7:0]	Response[31:0]
Get	F09h	00h	Bits [31:0] in the table below

Bit	Bitfield Name	RW	Default	Description
[31]	Presence Detect	R	0	0 = nothing plugged into Port-G 1 = something plugged into Port-G
[30:0]	Impedance Sense	R	00000000h	Impedance sense not supported

CONFIGURATION DEFAULT VERB

	Verb ID	Payload [7:0]	Response[31:0]
Get	F1Ch	00h	Bits [31:0] in the table below
Set1	71Ch	Bits [7:0] in the table below	00000000h
Set2	71Dh	Bits [15:8] in the table below	00000000h
Set3	71Eh	Bits [23:16] in the table below	00000000h
Set4	71Fh	Bits [31:24] in the table below	00000000h

Bit	Bitfield Name	RW	Default	Description
[31:30]	Port Connectivity	RW	0h	Indicates the external connectivity: 0h = Jack 1h = No physical connection 2h = A fixed function device 3h = both a jack and an internal device are connected
[29:28]	Location[5:4]	RW	0h	Gross physical location of the device connected to Port-G: 0h = External on primary chassis 1h = Internal 2h = Separate chassis 3h = Other
[27:24]	Location[3:0]	RW	1h	Geometric location of the device connected to Port-G: 0h = Not applicable 1h = Rear 2h = Front 3h = Left 4h = Right 5h = Top 6h = Bottom 7h = Special 8h = Special 9h = Special Ah-Fh = Reserved
[23:20]	Default Device	RW	0h	Indicates the intended use of Port-G: 0h = Line out 1h = Speaker 2h = Headphone out 3h = CD 4h = S/PDIF out 5h = Digital other out 6h = Modem line side 7h = Modem handset side 8h = Line in 9h = AUX Ah = Mic in Bh = Telephony Ch = S/PDIF in Dh = Digital other in Eh = Reserved Fh = Other

Bit	Bitfield Name	RW	Default	Description
[19:16]	Connection Type	RW	1h	Indicates the type of physical interface on Port-G: 0h = Unknown 1h = 3.5mm stereo/mono jack 2h = ¼" stereo/mono jack 3h = ATAPI internal 4h = RCA jack (for analogue audio or coaxial S/PDIF) 5h = Optical 6h = Other digital 7h = Other analogue 8h = Multi-channel analogue (DIN) 9h = XLR/Professional Ah = RJ-11 (modem) Bh = Combination Ch-Eh = Reserved Fh = Other
[15:12]	Colour	RW	6h	Indicates the colour of the physical jack on Port-G: 0h = Unknown 1h = Black 2h = Grey 3h = Blue 4h = Green 5h = Red 6h = Orange 7h = Yellow 8h = Purple 9h = Pink Ah-Dh = Reserved Eh = White Fh = Other
[11:8]	Misc	RW	0h	Presence detection override: 0 = Presence detection indicated by <i>Pin Capabilities Parameter</i> 1 = Presence detection not supported. If the <i>Pin Capabilities Parameter</i> indicates that that presence detection is supported by the node, then this bit is used to override it to indicate the external circuitry is not capable of supporting presence detect All other values are reserved
[7:4]	Default Association	RW	2h	Association number: 0h = Reserved 1h-Eh = Multi Channel or Single Pin Widget Fh = Single Pin Widget Only
[3:0]	Sequence	RW	1h	Sequence number used to define individual channel pairs within a stream. All values (0h-Fh) are available for use. Use a value of 0h for Single Pin Widget.

Note: The *Configuration Default Verb* is not reset to its default value during a reset from any source. The settings are only lost when digital power is removed from the WM8850. When digital power is restored, the System BIOS must restore the settings.

UNSOLICITED RESPONSE PRIORITY CONTROL VERB (VENDOR-SPECIFIC)

	Verb ID	Payload [7:0]	Response[31:0]
Get	F8Eh	00h	Bits [31:0] in the table below
Set	78Eh	Bits [7:0] in the table below	00000000h

Bit	Bitfield Name	RW	Default	Description
[31:5]	Rsvd	R	0000000h	Reserved
[4:0]	Priority	RW	00h	Assigns a priority setting for queued Unsolicited Responses. Nodes with the lowest value have the highest priority, and so go to the front of the Unsolicited Response queue. Nodes with the same value for priority are queued on first-to-trigger basis. 00h = Highest priority ... 1Fh = Lowest priority

00h
01h
02h
03h
04h
05h
06h
07h
08h
09h
0Ah
0Bh
0Ch
0Dh
0Eh
0Fh
10h
11h
12h
13h
14h
15h
16h
17h

PORT-F PIN COMPLEX WIDGET (NID = 13H)
GET PARAMETER VERB

	Verb ID	Payload [7:0]	Response[31:0]
Get	F00h	Parameter ID (PID)	Parameter Value

Audio Widget Capabilities Parameter (PID = 09h)

Bit	Bitfield Name	RW	Default	Description
[31:24]	Rsvd	R	00h	Reserved
[23:20]	Type	R	4h	Indicates that this is a Pin Complex Widget
[19:16]	Delay	R	0h	Latency not reported
[15:12]	Rsvd	R	0h	Reserved
[11]	L-R Swap	R	0	Left/Right swap capability not supported
[10]	PowerCntrl	R	0	Indicates that the <i>Power State Verb</i> is not supported in this widget
[9]	Digital	R	0	Indicates that this widget is translating analogue data
[8]	Conn List	R	1	Indicates that a connection list is present
[7]	Unsol Capable	R	1	Widget supports Unsolicited Responses
[6]	ProcWidget	R	0	Widget does not have processing capabilities
[5]	Stripe	R	0	Widget does not support striping
[4]	Format Override	R	0	Widget does not override the format defined for the AFG
[3]	Amp Parameter Override	R	0	Not applicable as this widget does not have amplifier capabilities
[2]	Out Amp Present	R	0	Output amplifier not present in this widget
[1]	In Amp Present	R	0	Input amplifier not present in this widget
[0]	Stereo	R	1	Indicates that this is a stereo widget

Pin Capabilities Parameter (PID = 0Ch)

Bit	Bitfield Name	RW	Default	Description
[31:17]	Rsvd	R	0000h	Reserved
[16]	EAPD Capable	R	0	Widget does not support an EAPD pin
[15:8]	VRef Control	R	00h	VRef not supported for digital outputs
[7]	Rsvd	R	0	Reserved
[6]	Balanced I/O Pins	R	0	Indicates that this widget does not have balanced pins
[5]	Input Capable	R	0	Indicates that this widget is not input capable
[4]	Output Capable	R	1	Indicates that this widget is output capable
[3]	Headphone Drive Capable	R	0	Indicates that this widget does not have a headphone driver
[2]	Presence Detect Capable	R	1	Indicates that this widget can perform presence detection
[1]	Trigger Required	R	0	Impedance measurement not supported
[0]	Impedance Sense Capable	R	0	Impedance measurement not supported

Connection List Length Parameter (PID = 0Eh)

Bit	Bitfield Name	RW	Default	Description
[31:8]	Rsvd	R	000000h	Reserved
[7]	Long Form	R	0	Indicates that the connection list items are in short form
[6:0]	Connection List Length	R	01h	Indicates that there is 1 NID entry in the connection list

GET CONNECTION LIST ENTRY VERB

	Verb ID	Payload [7:0]	Response[31:0]
Get	F02h	00h	Bits [31:0] in the table below

Bit	Bitfield Name	RW	Default	Description
[31:24]	Conn List Entry 3	R	00h	Unused connection list entry
[23:16]	Conn List Entry 2	R	00h	Unused connection list entry
[15:8]	Conn List Entry 1	R	00h	Unused connection list entry
[7:0]	Conn List Entry 0	R	08h	Indicates that the Port-F Pin Widget connects to the DAC3 Widget (NID = 08h)

PIN WIDGET CONTROL VERB

	Verb ID	Payload [7:0]	Response[31:0]
Get	F07h	00h	Bits [31:0] in the table below
Set	707h	Bits [7:0] in the table below	00000000h

Bit	Bitfield Name	RW	Default	Description
[31:8]	Rsvd	R	000000h	Reserved
[7]	H-Phn Enable	R	0	Not applicable for Port-F
[6]	Out Enable	RW	1	Controls the output path: 0 = Output path is disabled 1 = Output path is enabled
[5]	In Enable	R	0	Not applicable for Port-F
[4:3]	Rsvd	R	0h	Reserved
[2:0]	VRefEn	R	0h	Selectable VRef not supported

UNSOLICITED RESPONSE VERB

	Verb ID	Payload [7:0]	Response[31:0]
Get	F08h	00h	Bits [31:0] in the table below
Set	708h	Bits [7:0] in the table below	00000000h

Bit	Bitfield Name	RW	Default	Description
[31:8]	Rsvd	R	000000h	Reserved
[7]	Enable	RW	0	0 = Unsolicited Responses disabled for this node 1 = Unsolicited Responses enabled for this node
[6]	Rsvd	R	0	Reserved
[5:0]	Tag	RW	13h	A software programmable tag value that is returned in the top six bits (31:26) of every Unsolicited Response from this node. The default for <i>Tag</i> is equal to the Node ID.

Note: The Unsolicited Response for the AFG node is defined in the "Unsolicited Responses" section.

PIN SENSE VERB

	Verb ID	Payload [7:0]	Response[31:0]
Get	F09h	00h	Bits [31:0] in the table below

Bit	Bitfield Name	RW	Default	Description
[31]	Presence Detect	R	0	0 = nothing plugged into Port-F 1 = something plugged into Port-F
[30:0]	Impedance Sense	R	00000000h	Impedance sense not supported

CONFIGURATION DEFAULT VERB

	Verb ID	Payload [7:0]	Response[31:0]
Get	F1Ch	00h	Bits [31:0] in the table below
Set1	71Ch	Bits [7:0] in the table below	00000000h
Set2	71Dh	Bits [15:8] in the table below	00000000h
Set3	71Eh	Bits [23:16] in the table below	00000000h
Set4	71Fh	Bits [31:24] in the table below	00000000h

Bit	Bitfield Name	RW	Default	Description
[31:30]	Port Connectivity	RW	0h	Indicates the external connectivity: 0h = Jack 1h = No physical connection 2h = A fixed function device 3h = both a jack and an internal device are connected
[29:28]	Location[5:4]	RW	0h	Gross physical location of the device connected to Port-F: 0h = External on primary chassis 1h = Internal 2h = Separate chassis 3h = Other
[27:24]	Location[3:0]	RW	1h	Geometric location of the device connected to Port-F: 0h = Not applicable 1h = Rear 2h = Front 3h = Left 4h = Right 5h = Top 6h = Bottom 7h = Special 8h = Special 9h = Special Ah-Fh = Reserved
[23:20]	Default Device	RW	0h	Indicates the intended use of Port-F: 0h = Line out 1h = Speaker 2h = Headphone out 3h = CD 4h = S/PDIF out 5h = Digital other out 6h = Modem line side 7h = Modem handset side 8h = Line in 9h = AUX Ah = Mic in Bh = Telephony Ch = S/PDIF in Dh = Digital other in Eh = Reserved Fh = Other

Bit	Bitfield Name	RW	Default	Description
[19:16]	Connection Type	RW	1h	Indicates the type of physical interface on Port-F: 0h = Unknown 1h = 3.5mm stereo/mono jack 2h = ¼" stereo/mono jack 3h = ATAPI internal 4h = RCA jack (for analogue audio or coaxial S/PDIF) 5h = Optical 6h = Other digital 7h = Other analogue 8h = Multi-channel analogue (DIN) 9h = XLR/Professional Ah = RJ-11 (modem) Bh = Combination Ch-Eh = Reserved Fh = Other
[15:12]	Colour	RW	1h	Indicates the colour of the physical jack on Port-F: 0h = Unknown 1h = Black 2h = Grey 3h = Blue 4h = Green 5h = Red 6h = Orange 7h = Yellow 8h = Purple 9h = Pink Ah-Dh = Reserved Eh = White Fh = Other
[11:8]	Misc	RW	0h	Presence detection override: 0 = Presence detection indicated by Pin Capabilities Parameter (0Ch) 1 = Presence detection not supported. If the Pin Capabilities Parameter (0Ch) indicates that that presence detection is supported by the node, then this bit is used to override it to indicate the external circuitry is not capable of supporting presence detect All other values are reserved
[7:4]	Default Association	RW	2h	Association number: 0h = Reserved 1h-Eh = Multi Channel or Single Pin Widget Fh = Single Pin Widget Only
[3:0]	Sequence	RW	2h	Sequence number used to define individual channel pairs within a stream. All values (0h-Fh) are available for use. Use a value of 0h for Single Pin Widget.

Note: The *Configuration Default Verb* is not reset to its default value during a reset from any source. The settings are only lost when digital power is removed from the WM8850. When digital power is restored, the System BIOS must restore the settings.

UNSOLICITED RESPONSE PRIORITY CONTROL VERB (VENDOR-SPECIFIC)

	Verb ID	Payload [7:0]	Response[31:0]
Get	F8Eh	00h	Bits [31:0] in the table below
Set	78Eh	Bits [7:0] in the table below	00000000h

Bit	Bitfield Name	RW	Default	Description
[31:5]	Rsvd	R	0000000h	Reserved
[4:0]	Priority	RW	00h	Assigns a priority setting for queued Unsolicited Responses. Nodes with the lowest value have the highest priority, and so go to the front of the Unsolicited Response queue. Nodes with the same value for priority are queued on first-to-trigger basis. 00h = Highest priority ... 1Fh = Lowest priority

00h
01h
02h
03h
04h
05h
06h
07h
08h
09h
0Ah
0Bh
0Ch
0Dh
0Eh
0Fh
10h
11h
12h
13h
14h
15h
16h
17h

BEEP GENERATOR WIDGET (NID = 14H)
AMPLIFIER GAIN/MUTE VERB

	Verb ID	Payload [15:0]	Response[31:0]
Get	Bh	A000h	Bits [31:0] in the response table below – applies to the left channel only
Get	Bh	8000h	Bits [31:0] in the response table below – applies to the right channel only
Set	3h	Bits [15:0] in the set table below	00000000h

Response Table:

Bit	Bitfield Name	RW	Default	Description
[31:7]	Rsvd	R	000000h	Reserved
[6:0]	Amplifier Gain	R	04h	Shows the amplifier gain setting (step number) for the selected channel. The actual gain applied is determined by the <i>Output Amplifier Capabilities Parameter</i> , and is shown below for convenience: 00h = -24dB 01h = -18dB 02h = -12dB 03h = -6dB 04h = 0dB

Set Table:

Bit	Bitfield Name	RW	Default	Description
[15]	Set Output Amp	W	1	Indicates that the programming refers to the output amplifier on this widget
[14]	Set Input Amp	W	0	Not applicable to this widget
[13]	Set Left Amp	W	1	0 = Left channel amplifier does not accept the values in <i>Mute</i> or <i>Gain</i> fields 1 = Left channel amplifier does accept the values in the <i>Mute</i> and <i>Gain</i> fields
[12]	Set Right Amp	W	1	0 = Right channel amplifier does not accept the values in <i>Mute</i> or <i>Gain</i> fields 1 = Right channel amplifier does accept the values in the <i>Mute</i> and <i>Gain</i> fields
[11:8]	Index	W	0	Not applicable to this widget
[7]	Mute	R	1	Mute not supported
[6:0]	Gain	W	4h	Step number of the gain – see <i>Amplifier Gain</i> in response table above for details of actual gain values

GET PARAMETER VERB

	Verb ID	Payload [7:0]	Response[31:0]
Get	F00h	Parameter ID (PID)	Parameter Value

Audio Widget Capabilities Parameter (PID = 09h)

Bit	Bitfield Name	RW	Default	Description
[31:24]	Rsvd	R	00h	Reserved
[23:20]	Type	R	7h	Indicates that this is a Beep Generator Widget
[19:4]	Rsvd	R	0000h	Reserved
[3]	Amp Parameter Override	R	1	The AFG amplifier parameters are overridden for this node
[2]	Out Amp Present	R	1	Output amplifier is present in this widget
[1:0]	Rsvd	R	0h	Reserved

Output Amplifier Capabilities Response Format (PID = 12h)

Bit	Bitfield Name	RW	Default	Description
[31]	Mute Capable	R	0	Beep amplifier does not support mute
[30:23]	Rsvd	R	0000h	Reserved
[22:16]	Step Size	R	17h	Gain step size is 6dB
[15]	Rsvd	R	0	Reserved
[14:8]	Num Steps	R	04h	Number of steps in gain range is 5 (0dB to -24dB)
[7]	Rsvd	R	0	Reserved
[6:0]	Offset	R	04h	The step number that 0dB corresponds to is 04h

BEEP GENERATION VERB

	Verb ID	Payload [15:0]	Response[31:0]
Get	F0Ah	0000h	Bits [31:0] in the table below
Set	70Ah	Bits [15:0] in the table below	00000000h

Bit	Bitfield Name	RW	Default	Description
[31:8]	Rsvd	R	0000000h	Reserved
[7:0]	Terminal Count	RW	00h	<p>Sets tone divider value. The frequency of the beep tone is given by $f = 48\text{kHz} / (4 * \text{Divider})$:</p> <p>00h = Beep Generator disabled 01h = 12kHz 02h = 6 kHz FFh = 47.06 Hz</p> <p>Note: for a beep to be generated, the AFG must be in state D0</p>

BEEP MASK SELECTION VERB (VENDOR SPECIFIC)

	Verb ID	Payload [15:0]	Response[31:0]
Get	F72h	0000h	Bits [31:0] in the table below
Set	772h	Bits [15:0] in the table below	00000000h

Bit	Bitfield Name	RW	Default	Description
[31:3]	Rsvd	R	0000000h	Reserved
[2]	Port-A Beep Mask	RW	0	Beep mask enable for Port-A (DAC1): 0 = Beep tone unmasked from output 1 = Beep tone masked from output
[1]	Port-G Beep Mask	RW	0	Beep mask enable for Port-G (DAC2): 0 = Beep tone unmasked from output 1 = Beep tone masked from output
[0]	Port-F Beep Mask	RW	0	Beep mask enable for Port-F (DAC3): 0 = Beep tone unmasked from output 1 = Beep tone masked from output

00h
01h
02h
03h
04h
05h
06h
07h
08h
09h
0Ah
0Bh
0Ch
0Dh
0Eh
0Fh
10h
11h
12h
13h
14h
15h
16h
17h

MIC2 AUDIO INPUT CONVERTER WIDGET (NID = 15H)
STREAM FORMAT VERB

	Verb ID	Payload [15:0]	Response[31:0]
Get	Ah	0000h	Bits [31:0] in the table below

Bit	Bitfield Name	RW	Default	Description
[31:16]	Rsvd	R	0000h	Reserved
[15]	Type	R	0	Indicates the widget supports only PCM streams
[14]	Base	R	0	Used to set the base rate frequency: 0 = 48 kHz 1 = 44.1 kHz
[13:11]	Mult	R	0h	Used to set the base rate multiplication factor: 0h = x1 (48kHz, 44.1kHz or less) 1h = x2 (32kHz) 2h-7h = Reserved
[10:8]	Div	R	0h	Used to set the base rate division factor: 0h = divide by 1 (48kHz, 44.1kHz) 1h = divide by 2 (24kHz, 22.05kHz) 2h = divide by 3 (16kHz, 32kHz) 3h = divide by 4 (11.025kHz) 4h = Reserved 5h = divide by 6 (8kHz) 6h = Reserved 7h = Reserved
[7]	Rsvd	R	0	Reserved
[6:4]	Bits	R	3h	Bits per Sample: 0h = Reserved 1h = 16 bits 2h = 20 bits 3h = 24 bits 4h = 32 bits (Float 32) 5h-7h = Reserved
[3:0]	Chan	R	1h	Number of Channels in each frame of the stream: 0h = 1 channel 1h = 2 channels 2h = 3 channels 3h = 4 channels 4h-Fh = reserved

Note: Register values are read-only. As MIC2 and MIC1 share the DMICLK, the MIC1 *Stream Format Verb* is used to configure the sample rate for both converters.

GET PARAMETER VERB

	Verb ID	Payload [7:0]	Response[31:0]
Get	F00h	Parameter ID (PID)	Parameter Value

Audio Widget Capabilities Parameter (PID = 09h)

Bit	Bitfield Name	RW	Default	Description
[31:24]	Rsvd	R	00h	Reserved
[23:20]	Type	R	1h	Indicates that this is an Audio Input Widget
[19:16]	Delay	R	0h	Latency not reported
[15:12]	Rsvd	R	0h	Reserved
[11]	L-R Swap	R	0	Left/Right swap capability not supported
[10]	PowerCntrl	R	0	Indicates that the <i>Power State Verb</i> is not supported in this widget
[9]	Digital	R	1	Indicates that this widget is translating digital data
[8]	Conn List	R	1	Indicates that a connection list is present
[7]	Unsol Capable	R	1	Widget supports Unsolicited Responses
[6]	ProcWidget	R	1	Widget has processing capabilities (i.e high pass filter)
[5]	Stripe	R	0	Widget does not support striping
[4]	Format Override	R	1	Widget has a subset of the supported rates defined for the AFG
[3]	Amp Parameter Override	R	0	Not applicable as this widget does not have amplifier capabilities
[2]	Out Amp Present	R	0	Output amplifier not applicable for this widget
[1]	In Amp Present	R	0	Input amplifier not present in this widget
[0]	Stereo	R	1	Indicates that this is a stereo widget

Supported Rates Parameter (PID = 0Ah)

Bit	Bitfield Name	RW	Default	Description
[31:21]	Rsvd	R	000h	Reserved
[20]	B32	R	1	MIC1 supports 32-bit audio format
[19]	B24	R	1	MIC1 supports 24-bit audio format
[18]	B20	R	1	MIC1 supports 20-bit audio format
[17]	B16	R	1	MIC1 supports 16-bit audio format
[16]	B8	R	0	MIC1 does not support 8-bit audio format
[15:12]	Rsvd	R	0h	Reserved
[11]	R12	R	0	MIC1 does not support 384 kHz sample rate
[10]	R11	R	0	MIC1 does not support 192 kHz sample rate
[9]	R10	R	0	MIC1 does not support 176.4 kHz sample rate
[8]	R9	R	0	MIC1 does not support 96 kHz sample rate
[7]	R8	R	0	MIC1 does not support 88.2 kHz sample rate
[6]	R7	R	1	MIC1 supports 48 kHz sample rate
[5]	R6	R	1	MIC1 supports 44.1 kHz sample rate
[4]	R5	R	1	MIC1 supports 32 kHz sample rate
[3]	R4	R	1	MIC1 supports 22.05 kHz sample rate
[2]	R3	R	1	MIC1 supports 16 kHz sample rate
[1]	R2	R	1	MIC1 supports 11.025 kHz sample rate
[0]	R1	R	1	MIC1 supports 8 kHz sample rate

Supported Stream Formats Parameter (PID = 0Bh)

Bit	Bitfield Name	RW	Default	Description
[31:3]	Rsvd	R	00000000h	Reserved
[2]	AC3	R	0	MIC2 does not support Dolby AC3 formatted data
[1]	Float32	R	1	MIC2 supports Float32 formatted data
[0]	PCM	R	1	MIC2 supports PCM formatted data

Connection List Length Parameter (PID = 0Eh)

Bit	Bitfield Name	RW	Default	Description
[31:8]	Rsvd	R	000000h	Reserved
[7]	Long Form	R	0	Indicates that the connection list items are in short form
[6:0]	Connection List Length	R	01h	Indicates that there is 1 NID entry in the connection list

Processing Capabilities Parameter (PID = 10h)

Bit	Bitfield Name	RW	Default	Description
[31:16]	Rsvd	R	0000h	Reserved
[15:8]	NumCoeff	R	00h	This widget does not support loadable coefficients
[7:1]	Rsvd	R	00h	Reserved
[0]	Benign	R	0	The "Processing Benign State" is not supported

GET CONNECTION LIST ENTRY VERB

	Verb ID	Payload [7:0]	Response[31:0]
Get	F02h	00h	Bits [31:0] in the table below

Bit	Bitfield Name	RW	Default	Description
[31:24]	Conn List Entry 3	R	00h	Unused connection list entry
[23:16]	Conn List Entry 2	R	00h	Unused connection list entry
[15:8]	Conn List Entry 1	R	00h	Unused connection list entry
[7:0]	Conn List Entry 0	R	16h	Indicates that the MIC2 Widget connects to the Port-H Pin Widget (NID = 16h)

PROCESSING STATE VERB

	Verb ID	Payload [7:0]	Response[31:0]
Get	F03h	00h	Bits [31:0] in the table below
Set	703h	Bits [7:0] in the table below	00000000h

Bit	Bitfield Name	RW	Default	Description
[31:8]	Rsvd	R	000000h	Reserved
[7:0]	Processing State	RW	01h	The processing block is the high-pass filter (HPF). The processing state is controlled as follows: 00h = Processing Off: HPF disabled 01h = Processing On: HPF enabled 02h = Processing Off: HPF disabled (benign not supported) 03h-7Fh = Reserved 80h-FFh = Vendor Specific – not used

CONVERTER STREAM, CHANNEL VERB

	Verb ID	Payload [7:0]	Response[31:0]
Get	F06h	00h	Bits [31:0] in the table below
Set	706h	Bits [7:0] in the table below	00000000h

Bit	Bitfield Name	RW	Default	Description
[31:8]	Rsvd	R	0000000h	Reserved
[7:4]	Stream	RW	0h	Stream ID used by this widget. Note that Stream ID = 0h is used to indicate an unused stream, and converters will not transfer/receive link data for streams with an ID of 0h. For multi-channel capture on MIC1 and MIC2, the <i>Stream</i> value should be the same for both.
[3:0]	Channel	RW	2h	Lowest channel number used by this widget. Note: When MIC1 and MIC2 are setup for multi-channel capture, only a setting of 0h and 2h are applicable. However, the values are mutually exclusive, in that if <i>Channel</i> has been set to 0h for the MIC1 node, it must be set to 2h for the MIC2 node. Both nodes should have <i>Channel</i> set to 0h when not in multi-channel capture mode.

UNSOLICITED RESPONSE VERB

	Verb ID	Payload [7:0]	Response[31:0]
Get	F08h	00h	Bits [31:0] in the table below
Set	708h	Bits [7:0] in the table below	00000000h

Bit	Bitfield Name	RW	Default	Description
[31:8]	Rsvd	R	0000000h	Reserved
[7]	Enable	RW	0h	0 = Unsolicited Responses disabled for this node 1 = Unsolicited Responses enabled for this node
[6]	Rsvd	R	0h	Reserved
[5:0]	Tag	RW	15h	A software programmable tag value that is returned in the top six bits (31:26) of every Unsolicited Response from this node. The default for <i>Tag</i> is equal to the Node ID.

Note: The Unsolicited Response for the AFG node is defined in the "Unsolicited Responses" section.

UNSOLICITED RESPONSE PRIORITY CONTROL VERB (VENDOR-SPECIFIC)

	Verb ID	Payload [7:0]	Response[31:0]
Get	F8Eh	00h	Bits [31:0] in the table below
Set	78Eh	Bits [7:0] in the table below	00000000h

Bit	Bitfield Name	RW	Default	Description
[31:5]	Rsvd	R	00000000h	Reserved
[4:0]	Priority	RW	00h	Assigns a priority setting for queued Unsolicited Responses. Nodes with the lowest value have the highest priority, and so go to the front of the Unsolicited Response queue. Nodes with the same value for priority are queued on first-to-trigger basis. 00h = Highest priority ... 1Fh = Lowest priority

CHANNEL COPY VERB (VENDOR-SPECIFIC)

	Verb ID	Payload [7:0]	Response[31:0]
Get	FB1h	00h	Bits [31:0] in the table below
Set	7B1h	Bits [7:0] in the table below	00000000h

Bit	Bitfield Name	RW	Default	Description
[31:2]	Rsvd	R	00000000h	Reserved
[1]	CHAN1_SEL	RW	1	Channel 1 (right) Mapping Control: 0 = Channel takes data from left channel 1 = Channel takes data from right channel
[0]	CHAN0_SEL	RW	0	Channel 0 (left) Mapping Control: 0 = Channel takes data from left channel 1 = Channel takes data from right channel

00h
01h
02h
03h
04h
05h
06h
07h
08h
09h
0Ah
0Bh
0Ch
0Dh
0Eh
0Fh
10h
11h
12h
13h
14h
15h
16h
17h

PORT-H PIN COMPLEX WIDGET (NID = 16H)
AMPLIFIER GAIN/MUTE VERB

	Verb ID	Payload [15:0]	Response[31:0]
Get	Bh	2000h	Bits [31:0] in the response table below – applies to the left channel only
Get	Bh	0000h	Bits [31:0] in the response table below – applies to the right channel only
Set	3h	Bits [7:0] in the set table below	00000000h

Response Table:

Bit	Bitfield Name	RW	Default	Description
[31:8]	Rsvd	R	000000h	Reserved
[7]	Amplifier Mute	R	0	Shows the amplifier mute status of the selected channel: 0 = Normal 1 = Muted
[6:0]	Amplifier Gain	R	18h	Shows the amplifier gain setting (step number) for the selected channel. The actual gain applied is determined by the <i>Input Amplifier Capabilities Parameter</i> in the AFG (NID = 01h), and is shown below for convenience: 00h = -12dB 01h = -11.5dB ... -0.5dB steps 57h = +31.5dB 58h = +32dB

Set Table:

Bit	Bitfield Name	RW	Default	Description
[15]	Set Output Amp	W	0	Not applicable to this widget
[14]	Set Input Amp	W	1	Indicates that the programming refers to the input amplifier on this widget
[13]	Set Left Amp	W	1	0 = Left channel amplifier does not accept the values in <i>Mute</i> or <i>Gain</i> fields 1 = Left channel amplifier does accept the values in the <i>Mute</i> and <i>Gain</i> fields
[12]	Set Right Amp	W	1	0 = Right channel amplifier does not accept the values in <i>Mute</i> or <i>Gain</i> fields 1 = Right channel amplifier does accept the values in the <i>Mute</i> and <i>Gain</i> fields
[11:8]	Index	W	0h	Not applicable to this widget
[7]	Mute	W	0	0 = Normal operation 1 = Mute
[6:0]	Gain	W	18h	Step number of the gain – see <i>Amplifier Gain</i> in response table above for details of actual gain values

GET PARAMETER VERB

	Verb ID	Payload [7:0]	Response[31:0]
Get	F00h	Parameter ID (PID)	Parameter Value

Audio Widget Capabilities Parameter (PID = 09h)

Bit	Bitfield Name	RW	Default	Description
[31:24]	Rsvd	R	00h	Reserved
[23:20]	Type	R	4h	Indicates that this is a Pin Complex Widget
[19:16]	Delay	R	0h	Latency not reported
[15:12]	Rsvd	R	0h	Reserved
[11]	L-R Swap	R	0	Left/Right swap capability not supported
[10]	PowerCntrl	R	0	Indicates that the <i>Power State Verb</i> is not supported in this widget
[9]	Digital	R	1	Indicates that this widget is translating digital data
[8]	Conn List	R	1	Indicates that a connection list is present
[7]	Unsol Capable	R	0	Widget does not support Unsolicited Responses
[6]	ProcWidget	R	0	Widget does not have processing capabilities
[5]	Stripe	R	0	Widget does not support striping
[4]	Format Override	R	0	Widget does not override the format defined for the AFG
[3]	Amp Parameter Override	R	1	The AFG amplifier parameters are overridden for this node
[2]	Out Amp Present	R	0	Output amplifier not present in this widget
[1]	In Amp Present	R	1	Input amplifier is present in this widget
[0]	Stereo	R	1	Indicates that this is a stereo widget

Pin Capabilities Parameter (PID = 0Ch)

Bit	Bitfield Name	RW	Default	Description
[31:17]	Rsvd	R	0000h	Reserved
[16]	EAPD Capable	R	0	Widget does not support an EAPD pin
[15:8]	VRef Control	R	00h	VRef not supported for digital inputs
[7]	Rsvd	R	0	Reserved
[6]	Balanced I/O Pins	R	0	Indicates that this widget does not have balanced pins
[5]	Input Capable	R	1	Indicates that this widget is input capable
[4]	Output Capable	R	1	Indicates that this widget is output capable
[3]	Headphone Drive Capable	R	0	Not applicable as this in an input port
[2]	Presence Detect Capable	R	0	Presence detection not supported
[1]	Trigger Required	R	0	Impedance measurement not supported
[0]	Impedance Sense Capable	R	0	Impedance measurement not supported

Input Amplifier Capabilities Response Format (PID = 0Dh)

Bit	Bitfield Name	RW	Default	Description
[31]	Mute Capable	R	1	DMIC Amplifiers are capable of hard-mute
[30:23]	Rsvd	R	00h	Reserved
[22:16]	Step Size	R	01h	Gain step size is 0.5dB
[15]	Rsvd	R	0	Reserved
[14:8]	Num Steps	R	58h	Number of steps in gain range is 89 (-12dB to +32dB)
[7]	Rsvd	R	0	Reserved
[6:0]	Offset	R	18h	The step number that 0dB corresponds to is 18h

Connection List Length Parameter (PID = 0Eh)

Bit	Bitfield Name	RW	Default	Description
[31:8]	Rsvd	R	000000h	Reserved
[7]	Long Form	R	0	Indicates that the connection list items are in short form
[6:0]	Connection List Length	R	01h	Indicates that there is 1 NID entry in the connection list

GET CONNECTION LIST ENTRY VERB

	Verb ID	Payload [7:0]	Response[31:0]
Get	F02h	00h	Bits [31:0] in the table below

Bit	Bitfield Name	RW	Default	Description
[31:24]	Conn List Entry 3	R	00h	Unused connection list entry
[23:16]	Conn List Entry 2	R	00h	Unused connection list entry
[15:8]	Conn List Entry 1	R	00h	Unused connection list entry
[7:0]	Conn List Entry 0	R	17h	Indicates that the Port-H Pin Widget connects to the S/PDIF Tx 2 Widget (NID = 17h)

PIN WIDGET CONTROL VERB

	Verb ID	Payload [7:0]	Response[31:0]
Get	F07h	00h	Bits [31:0] in the table below
Set	707h	Bits [7:0] in the table below	00000000h

Bit	Bitfield Name	RW	Default	Description
[31:8]	Rsvd	R	000000h	Reserved
[7]	H-Phn Enable	R	0	Not applicable as this in an input port
[6]	Out Enable	RW	0	Controls the output path: 0 = Output path is disabled 1 = Output path is enabled
[5]	In Enable	RW	1	Controls the input path: 0 = Input path is disabled 1 = Input path is enabled
[4:3]	Rsvd	R	0h	Reserved
[2:0]	VRefEn	R	0h	Selectable VRef not supported

Note: It is erroneous behaviour for both the *Out Enable* and *In Enable* registers to be set high simultaneously. If both registers are set, Port-H defaults to an input.

CONFIGURATION DEFAULT VERB

	Verb ID	Payload [7:0]	Response[31:0]
Get	F1Ch	00h	Bits [31:0] in the table below
Set1	71Ch	Bits [7:0] in the table below	00000000h
Set2	71Dh	Bits [15:8] in the table below	00000000h
Set3	71Eh	Bits [23:16] in the table below	00000000h
Set4	71Fh	Bits [31:24] in the table below	00000000h

Bit	Bitfield Name	RW	Default	Description
[31:30]	Port Connectivity	RW	0h	Indicates the external connectivity: 0h = Jack 1h = No physical connection 2h = A fixed function device 3h = both a jack and an internal device are connected
[29:28]	Location[5:4]	RW	1h	Gross physical location of the device connected to Port-H: 0h = External on primary chassis 1h = Internal 2h = Separate chassis 3h = Other
[27:24]	Location[3:0]	RW	0h	Geometric location of the device connected to Port-H: 0h = Not applicable 1h = Rear 2h = Front 3h = Left 4h = Right 5h = Top 6h = Bottom 7h = Special 8h = Special 9h = Special Ah-Fh = Reserved
[23:20]	Default Device	RW	Ah	Indicates the intended use of Port-H: 0h = Line out 1h = Speaker 2h = Headphone out 3h = CD 4h = S/PDIF out 5h = Digital other out 6h = Modem line side 7h = Modem handset side 8h = Line in 9h = AUX Ah = Mic in Bh = Telephony Ch = S/PDIF in Dh = Digital other in Eh = Reserved Fh = Other

Bit	Bitfield Name	RW	Default	Description
[19:16]	Connection Type	RW	6h	Indicates the type of physical interface on Port-H: 0h = Unknown 1h = 3.5mm stereo/mono jack 2h = ¼" stereo/mono jack 3h = ATAPI internal 4h = RCA jack (for analogue audio or coaxial S/PDIF) 5h = Optical 6h = Other digital 7h = Other analogue 8h = Multi-channel analogue (DIN) 9h = XLR/Professional Ah = RJ-11 (modem) Bh = Combination Ch-Eh = Reserved Fh = Other
[15:12]	Colour	RW	0h	Indicates the colour of the physical jack on Port-H: 0h = Unknown 1h = Black 2h = Grey 3h = Blue 4h = Green 5h = Red 6h = Orange 7h = Yellow 8h = Purple 9h = Pink Ah-Dh = Reserved Eh = White Fh = Other
[11:8]	Misc	RW	1h	Presence detection override: 0h = Presence detection indicated by <i>Pin Capabilities Parameter</i> 1h = Presence detection not supported. If the <i>Pin Capabilities Parameter</i> indicates that that presence detection is supported by the node, then this bit is used to override it to indicate the external circuitry is not capable of supporting presence detect All other values are reserved
[7:4]	Default Association	RW	Fh	Association number: 0h = Reserved 1h-Eh = Multi Channel or Single Pin Widget Fh = Single Pin Widget Only
[3:0]	Sequence	RW	0h	Sequence number used to define individual channel pairs within a stream. All values (0h-Fh) are available for use. Use a value of 0 for Single Pin Widget.

Note: The *Configuration Default Verb* is not reset to its default value during a reset from any source. The settings are only lost when digital power is removed from the WM8850. When digital power is restored, the System BIOS must restore the settings.

INTERNAL PATH VERB (VENDOR-SPECIFIC)

	Verb ID	Payload [7:0]	Response[31:0]
Get	F73h	00h	Bits [31:0] in the table below
Set	773h	Bits [7:0] in the table below	00000000h

Bit	Bitfield Name	RW	Default	Description
[31:8]	Rsvd	R	00000000h	Reserved
[7:0]	Path Sel	RW	17h	Selects source of Port-H node: 10h = Use data from SPDIF_IN (NID=10h) 17h = Use data from S/PDIF Tx2 (NID=17h)

S/PDIF TX 2 AUDIO OUTPUT CONVERTER WIDGET (NID = 17H)
STREAM FORMAT VERB

	Verb ID	Payload [15:0]	Response[31:0]
Get	Ah	0000h	Bits [31:0] in the table below
Set	2h	Bits [15:0] in the table below	00000000h

Bit	Bitfield Name	RW	Default	Description
[31:16]	Rsvd	R	0000h	Reserved
[15]	Type	RW	0	Used to set the format of the stream: 0 = PCM 1 = Non-PCM (i.e. AC3 or Software Formatted S/PDIF)
[14]	Base	RW	0	Used to set the base rate frequency: 0h = 48 kHz 1h = 44.1 kHz
[13:11]	Mult	RW	0h	Used to set the base rate multiplication factor: 0h = x1 (48kHz, 44.1kHz or less) 1h = x2 (96kHz, 88.2kHz, 32kHz) 2h = Reserved 3h = x4 (192kHz, 176.4kHz) 4h-7h = Reserved
[10:8]	Div	RW	0h	Used to set the base rate division factor: 0h = divide by 1 (48kHz, 44.1kHz) 1h = Reserved 2h = divide by 3 (32kHz) 3h-7h = Reserved
[7]	Rsvd	R	0	Reserved
[6:4]	Bits	RW	4h	Bits per Sample: 0h = Reserved 1h = 16 bits 2h = 20 bits 3h = 24 bits 4h = 32 bits (Software Formatted or Float 32) 5h-7h = Reserved
[3:0]	Chan	RW	1h	Number of Channels in each frame of the stream: 0h = 1 channel 1h = 2 channels 2h-Fh = reserved

Notes:

1. When Software Formatted S/PDIF is selected, verb settings for channel status and validity are not used.
2. When Software Formatted S/PDIF is selected, the S/PDIF output is driven low until Stream ID is assigned.

GET PARAMETER VERB

	Verb ID	Payload [7:0]	Response[31:0]
Get	F00h	Parameter ID (PID)	Parameter Value

Audio Widget Capabilities Parameter (PID = 09h)

Bit	Bitfield Name	RW	Default	Description
[31:24]	Rsvd	R	00h	Reserved
[23:20]	Type	R	0h	Indicates that this is an Audio Output Widget
[19:16]	Delay	R	0h	Latency not reported
[15:12]	Rsvd	R	0h	Reserved
[11]	L-R Swap	R	0	Left/Right swap capability not supported
[10]	PowerCntrl	R	0	Indicates that the <i>Power State Verb</i> is supported in this widget
[9]	Digital	R	1	Indicates that this widget is translating digital data
[8]	Conn List	R	0	Indicates that a connection list is not present
[7]	Unsol Capable	R	1	Widget supports Unsolicited Responses
[6]	ProcWidget	R	0	Widget does not have processing capabilities
[5]	Stripe	R	0	Widget does not support striping
[4]	Format Override	R	1	Widget has a subset of the supported rates defined for the AFG
[3]	Amp Parameter Override	R	0	Not applicable as this widget does not have amplifier capabilities
[2]	Out Amp Present	R	0	Output amplifier not present in this widget
[1]	In Amp Present	R	0	Input amplifier not present in this widget
[0]	Stereo	R	1	Indicates that this is a stereo widget

Supported Rates Parameter (PID = 0Ah)

Bit	Bitfield Name	RW	Default	Description
[31:21]	Rsvd	R	000h	Reserved
[20]	B32	R	1	Float32 and Software Formatted S/PDIFs supported.
[19]	B24	R	1	S/PDIF Tx 2 supports 24-bit audio format
[18]	B20	R	1	S/PDIF Tx 2 supports 20-bit audio format
[17]	B16	R	1	S/PDIF Tx 2 supports 16-bit audio format
[16]	B8	R	0	S/PDIF Tx 2 does not support 8-bit audio format
[15:12]	Rsvd	R	0h	Reserved
[11]	R12	R	0	S/PDIF Tx 2 does not support 384 kHz sample rate
[10]	R11	R	1	S/PDIF Tx 2 supports 192 kHz sample rate
[9]	R10	R	1	S/PDIF Tx 2 supports 176.4 kHz sample rate
[8]	R9	R	1	S/PDIF Tx 2 supports 96 kHz sample rate
[7]	R8	R	1	S/PDIF Tx 2 supports 88.2 kHz sample rate
[6]	R7	R	1	S/PDIF Tx 2 supports 48 kHz sample rate
[5]	R6	R	1	S/PDIF Tx 2 supports 44.1 kHz sample rate
[4]	R5	R	1	S/PDIF Tx 2 supports 32 kHz sample rate
[3]	R4	R	0	S/PDIF Tx 2 does not support 22.05 kHz sample rate
[2]	R3	R	0	S/PDIF Tx 2 does not support 16 kHz sample rate
[1]	R2	R	0	S/PDIF Tx 2 does not support 11.025 kHz sample rate
[0]	R1	R	0	S/PDIF Tx 2 does not support 8 kHz sample rate

Supported Stream Formats Parameter (PID = 0Bh)

Bit	Bitfield Name	RW	Default	Description
[31:3]	Rsvd	R	00000000h	Reserved
[2]	AC3	R	0	S/PDIF Tx 2 does not support Dolby AC3 format
[1]	Float32	R	1	S/PDIF Tx 2 supports Float32 formatted data
[0]	PCM	R	1	S/PDIF Tx 2 PCM formatted data

CONVERTER STREAM, CHANNEL VERB

	Verb ID	Payload [7:0]	Response[31:0]
Get	F06h	00h	Bits [31:0] in the table below
Set	706h	Bits [7:0] in the table below	00000000h

Bit	Bitfield Name	RW	Default	Description
[31:8]	Rsvd	R	000000h	Reserved
[7:4]	Stream	RW	0h	Stream ID used by this widget. Note that Stream ID = 0h is used to indicate an unused stream, and converters will not transfer/receive link data for streams with an ID of 0h.
[3:0]	Channel	RW	0h	Lowest channel number used by this widget. Note: As this widget does not support multi-channel capture, only a setting of 0 is applicable.

UNSOLICITED RESPONSE VERB

	Verb ID	Payload [7:0]	Response[31:0]
Get	F08h	00h	Bits [31:0] in the table below
Set	708h	Bits [7:0] in the table below	00000000h

Bit	Bitfield Name	RW	Default	Description
[31:8]	Rsvd	R	000000h	Reserved
[7]	Enable	RW	0	0 = Unsolicited Responses disabled for this node 1 = Unsolicited Responses enabled for this node
[6]	Rsvd	R	0	Reserved
[5:0]	Tag	RW	17h	A software programmable tag value that is returned in the top six bits (31:26) of every Unsolicited Response from this node. The default for <i>Tag</i> is equal to the Node ID.

Note: The Unsolicited Response for the AFG node is defined in the “Unsolicited Responses” section.

S/PDIF CONVERTER CONTROL VERB

	Verb ID	Payload [7:0]	Response[31:0]
Get	F0Dh	0000h	Bits [31:0] in the table below
Set1	70Dh	Bits [7:0] in the table below	00000000h
Set2	70Eh	Bits [15:8] in the table below	00000000h

Bit	Bitfield Name	RW	Default	Description
[31:15]	Rsvd	R	00000h	Reserved
[14:8]	CC	RW	00h	Category Code. Channel Status bits [14:8] – see IEC 60958-3 for details.
[7]	L	RW	0	Generation Level, Channel Status bit [15] - see IEC 60958-3 for details.
[6]	PRO	RW	0	Professional, Channel Status bit[0]: 0 = Consumer Channel Status (40-bits) 1 = Professional Channel Status (192-bits)
[5]	/AUDIO	RW	0	Non-Audio, Channel Status bit[1]: 0 = PCM formatted data 1 = non-PCM formatted data
[4]	COPY	RW	0	Copyright, Channel Status bit[2]: 0 = indicates copyright asserted (i.e. S/PDIF Channel Status bit[2] set to 1) 1 = indicates no copyright asserted (.e. S/PDIF Channel Status bit[2] set to 0) Note, that the HDA spec, and the IEC 60958-3 spec are the inverse of each other. To comply with both, the CODEC inverts the written value.
[3]	PRE	RW	0	Pre-emphasis, Channel Status bit[3]: 0 = no pre-emphasis 1 = 50/15 us pre-emphasis
[2]	VCFG	RW	0	Validity Configuration Control - determines what happens to the audio data, should an invalid sample occur (invalid samples occur when SRC2 is in use but not locked, EF_STREAM_ERR is asserted, or the stream ID is 0). 0 = pass data as received by the S/PDIF Tx 2. 1 = overwrite invalid data with all zeros (for the invalid sub frame only).
[1]	V	RW	0	Validity: 0 = Indicates valid data 1 = Indicates invalid data If V=1, the transmitted <i>validity</i> flag is set to 1. If V=0, the transmitted <i>validity</i> flag is set to 1 if there is an invalid sample being transmitted. Invalid samples may occur when SRC2 is in use but not locked, EF_STREAM_ERR is asserted, or the stream ID is 0.
[0]	DigEn	RW	0	Digital Enable: 0 = S/PDIF audio path disabled 1 = S/PDIF audio path enabled

Note: When Software Formatted S/PDIF is selected, verb settings for channel status and validity are not used

INTERNAL PATH VERB (VENDOR-SPECIFIC)

	Verb ID	Payload [7:0]	Response[31:0]
Get	F73h	00h	Bits [31:0] in the table below
Set1	773h	Bits [7:0] in the table below	00000000h

Bit	Bitfield Name	RW	Default	Description
[31:8]	Rsvd	R	0000000h	Reserved
[7:0]	Path Sel	RW	00h	Selects source of S/PDIF TX 2 node: 00h = HDA Link 02h = ADC1 03h = MIC1 15h = MIC2 All other values of Path Sel are reserved.

TX CHANNEL STATUS CONTROL VERB (VENDOR-SPECIFIC)

	Verb ID	Payload [7:0]	Response[31:0]
Get	F81h	00h	Bits [31:0] in the table below
Set1	781h	Bits [7:0] in the table below	00000000h
Set2	782h	Bits [15:8] in the table below	00000000h
Set3	783h	Bits [23:16] in the table below	00000000h
Set4	784h	Bits [31:24] in the table below	00000000h

The bits in the table below are defined in the IEC-60958-3 Specification:

Bit	Bitfield Name	RW	Default	Description
[31:28]	Channel Status [39:36]	RW	0h	Original Sampling Frequency
[27:25]	Channel Status [35:33]	RW	5h	Sample Word Length
[24]	Channel Status [32]	RW	1	Max Word Length
[23:22]	Channel Status [31:30]	RW	0h	Channel Status [31:30]
[21:20]	Channel Status [29:28]	RW	0h	Clock Accuracy
[19:16]	Channel Status [27:24]	RW	1h	Sampling Frequency
[15:12]	Channel Status B [23:20]	RW	0h	Channel Number for Sub-Frame B
[11:8]	Channel Status [23:20]	RW	0h	Channel Number for Sub-Frame A
[7:4]	Channel Status [19:16]	RW	0h	Source Number
[3:2]	Channel Status [7:6]	RW	0h	Channel Status Mode
[1:0]	Channel Status [5:4]	RW	0h	Additional De-emphasis Information

Notes:

1. When Software Formatted S/PDIF is selected, verb settings for channel status and validity are not used.
2. The *Channel Number* for Sub-frame B is uniquely configurable – all other Channel status bits have the same value as Sub-frame A.

CHANNEL STATUS DATA PACKING CONFIGURATION VERB (VENDOR-SPECIFIC)

	Verb ID	Payload [7:0]	Response[31:0]
Get	F85h	00h	Bits [31:0] in the table below
Set	785h	Bits [7:0] in the table below	00000000h

Bit	Bitfield Name	RW	Default	Description
[31:1]	Rsvd	R	0000000h	Reserved
[0]	CSD_MODE	RW	1	S/PDIF Transmitter Channel Status Data Packing Mode: 0 = Manual mode: sample rate and data width channel status data packed from data sourced from the <i>Tx Channel Status Control Verb</i> 1 = Automatic mode: sample rate and data width channel status data packed from data sourced from the <i>Stream Verb</i> , <i>S/PDIF Verb</i> or <i>S/PDIF Rx Rate Detector</i> (depending on routing through device)

UNSOLICITED RESPONSE PRIORITY CONTROL VERB (VENDOR-SPECIFIC)

	Verb ID	Payload [7:0]	Response[31:0]
Get	F8Eh	00h	Bits [31:0] in the table below
Set	78Eh	Bits [7:0] in the table below	00000000h

Bit	Bitfield Name	RW	Default	Description
[31:5]	Rsvd	R	0000000h	Reserved
[4:0]	Priority	RW	00h	Assigns a priority setting for queued Unsolicited Responses. Nodes with the lowest value have the highest priority, and so go to the front of the Unsolicited Response queue. Nodes with the same value for priority are queued on first-to-trigger basis. 00h = Highest priority ... 1Fh = Lowest priority

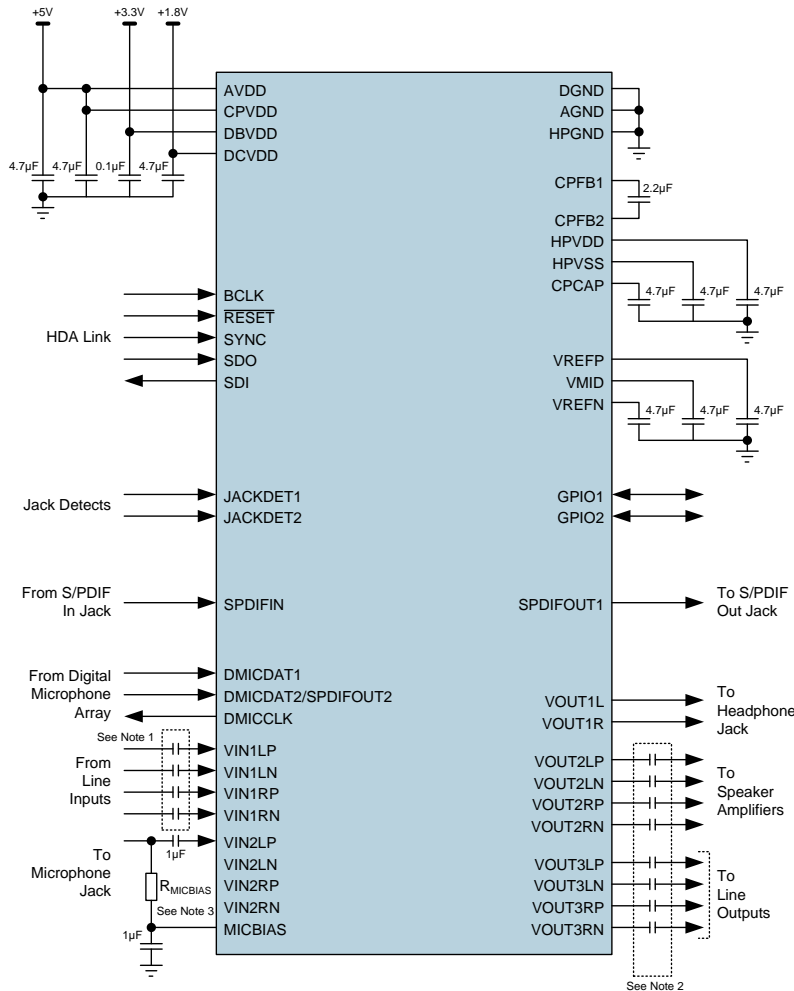
APPLICATIONS INFORMATION
RECOMMENDED EXTERNAL COMPONENTS

Figure 23 Recommended External Components
Notes:

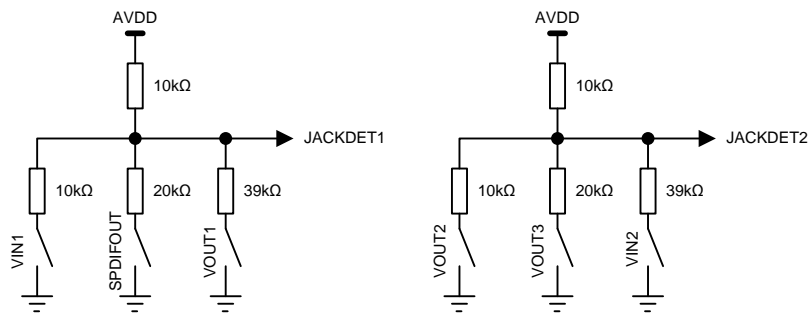
1. AC-coupling capacitors for inputs may depend on circuitry used prior to WM8850. Typical values between 1µF and 10µF are common – consult any documentation for the exact circuit used
2. AC-coupling capacitors for outputs may depend in circuitry used after WM8850. Typical values between 1µF and 10µF are common – consult any documentation for the exact circuit used
3. A single-ended mono microphone input is shown, but other configurations are equally valid. The value of the microphone bias resistor will vary with the microphone used – a typical value is 2.2kΩ
4. The capacitor between CFB1 and CFB2 must be placed as close as possible to the device pins
5. The decoupling capacitor on CPCAP must also be placed as close as possible to the device pins
6. The decoupling capacitor on CPVDD is next important – it too should be placed as close as possible to the device pins
7. The decoupling capacitors on VREFP, VREFN and VMID are next important, in that order
8. All remaining decoupling capacitors should then be placed as close as possible

REQUIRED JACK DETECT COMPONENTS

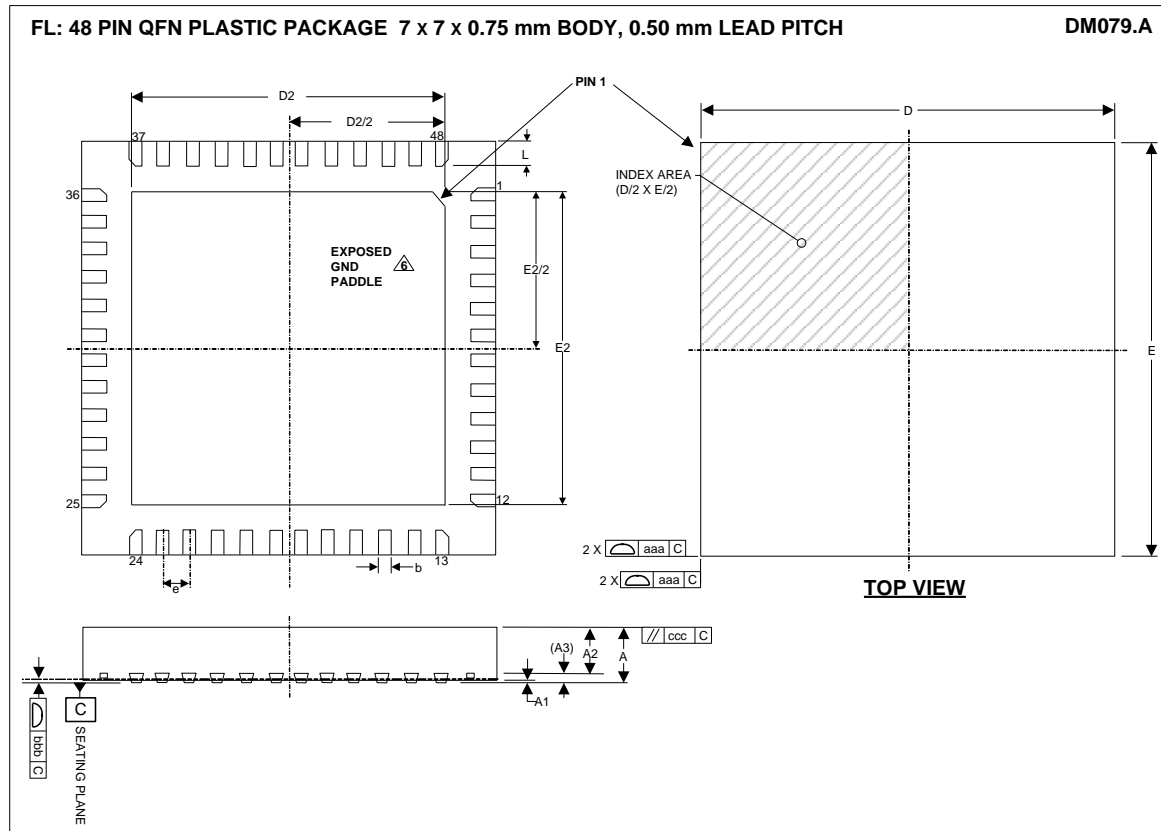
Figure 24 Required Jack Detect Components

The WM8850 supports jack detect on all analogue input and output ports, as well as on the S/PDIF output. This is implemented as per the High Definition Audio Specification Revision 1.0, section 7.4.2 and as such requires the resistor values shown in Figure 24 above. Note that, as per the High Definition Audio Specification, it is a requirement that the tolerance on these resistors is 1% or better.

PACKAGE DIMENSIONS

Symbols	Dimensions (mm)			NOTE
	MIN	NOM	MAX	
A	0.7	0.75	0.8	
A1	0	0.035	0.05	
A2	-	0.55	0.57	
A3		0.203 REF		
b	0.20	0.25	0.30	1
D		7.00 BSC		
D2	5.55	5.65	5.75	
E		7.00 BSC		
E2	5.55	5.65	5.75	
e		0.5 BSC		
L	0.35	0.4	0.45	
Tolerances of Form and Position				
aaa	0.10			
bbb	0.08			
ccc	0.10			
REF	JEDEC, MO-220			

NOTES:

1. DIMENSION b APPLIED TO METALLIZED TERMINAL AND IS MEASURED BETWEEN 0.15 mm AND 0.30 mm FROM TERMINAL TIP.
2. ALL DIMENSIONS ARE IN MILLIMETRES
3. THE TERMINAL #1 IDENTIFIER AND TERMINAL NUMBERING CONVENTION SHALL CONFORM TO JESD 95-1 SPP-002.
4. COPLANARITY APPLIES TO THE EXPOSED HEAT SINK SLUG AS WELL AS THE TERMINALS.
5. THIS DRAWING IS SUBJECT TO CHANGE WITHOUT NOTICE.
6. REFER TO APPLICATIONS NOTE WAN_0118 FOR FURTHER INFORMATION.

IMPORTANT NOTICE

Contacting Cirrus Logic Support

For all product questions and inquiries, contact a Cirrus Logic Sales Representative.

To find one nearest you, go to www.cirrus.com.

For the purposes of our terms and conditions of sale, "Preliminary" or "Advanced" datasheets are non-final datasheets that include but are not limited to datasheets marked as "Target", "Advance", "Product Preview", "Preliminary Technical Data" and/or "Pre-production." Products provided with any such datasheet are therefore subject to relevant terms and conditions associated with "Preliminary" or "Advanced" designations. The products and services of Cirrus Logic International (UK) Limited; Cirrus Logic, Inc.; and other companies in the Cirrus Logic group (collectively either "Cirrus Logic" or "Cirrus") are sold subject to Cirrus Logic's terms and conditions of sale supplied at the time of order acknowledgment, including those pertaining to warranty, indemnification, and limitation of liability. Software is provided pursuant to applicable license terms. Cirrus Logic reserves the right to make changes to its products and specifications or to discontinue any product or service without notice. Customers should therefore obtain the latest version of relevant information from Cirrus Logic to verify that the information is current and complete. Testing and other quality control techniques are utilized to the extent Cirrus Logic deems necessary. Specific testing of all parameters of each device is not necessarily performed. In order to minimize risks associated with customer applications, the customer must use adequate design and operating safeguards to minimize inherent or procedural hazards. Cirrus Logic is not liable for applications assistance or customer product design. The customer is solely responsible for its selection and use of Cirrus Logic products. Use of Cirrus Logic products may entail a choice between many different modes of operation, some or all of which may require action by the user, and some or all of which may be optional. Nothing in these materials should be interpreted as instructions or suggestions to choose one mode over another. Likewise, description of a single mode should not be interpreted as a suggestion that other modes should not be used or that they would not be suitable for operation. Features and operations described herein are for illustrative purposes only.

CERTAIN APPLICATIONS USING SEMICONDUCTOR PRODUCTS MAY INVOLVE POTENTIAL RISKS OF DEATH, PERSONAL INJURY, OR SEVERE PROPERTY OR ENVIRONMENTAL DAMAGE ("CRITICAL APPLICATIONS"). CIRRUS LOGIC PRODUCTS ARE NOT DESIGNED, AUTHORIZED OR WARRANTED FOR USE IN PRODUCTS SURGICALLY IMPLANTED INTO THE BODY, AUTOMOTIVE SAFETY OR SECURITY DEVICES, NUCLEAR SYSTEMS, LIFE SUPPORT PRODUCTS OR OTHER CRITICAL APPLICATIONS. INCLUSION OF CIRRUS LOGIC PRODUCTS IN SUCH APPLICATIONS IS UNDERSTOOD TO BE FULLY AT THE CUSTOMER'S RISK AND CIRRUS LOGIC DISCLAIMS AND MAKES NO WARRANTY, EXPRESS, STATUTORY OR IMPLIED, INCLUDING THE IMPLIED WARRANTIES OF MERCHANTABILITY AND FITNESS FOR PARTICULAR PURPOSE, WITH REGARD TO ANY CIRRUS LOGIC PRODUCT THAT IS USED IN SUCH A MANNER. IF THE CUSTOMER OR CUSTOMER'S CUSTOMER USES OR PERMITS THE USE OF CIRRUS LOGIC PRODUCTS IN CRITICAL APPLICATIONS, CUSTOMER AGREES, BY SUCH USE, TO FULLY INDEMNIFY CIRRUS LOGIC, ITS OFFICERS, DIRECTORS, EMPLOYEES, DISTRIBUTORS AND OTHER AGENTS FROM ANY AND ALL LIABILITY, INCLUDING ATTORNEYS' FEES AND COSTS, THAT MAY RESULT FROM OR ARISE IN CONNECTION WITH THESE USES.

This document is the property of Cirrus Logic and by furnishing this information, Cirrus Logic grants no license, express or implied, under any patents, mask work rights, copyrights, trademarks, trade secrets or other intellectual property rights. Any provision or publication of any third party's products or services does not constitute Cirrus Logic's approval, license, warranty or endorsement thereof. Cirrus Logic gives consent for copies to be made of the information contained herein only for use within your organization with respect to Cirrus Logic integrated circuits or other products of Cirrus Logic, and only if the reproduction is without alteration and is accompanied by all associated copyright, proprietary and other notices and conditions (including this notice). This consent does not extend to other copying such as copying for general distribution, advertising or promotional purposes, or for creating any work for resale. This document and its information is provided "AS IS" without warranty of any kind (express or implied). All statutory warranties and conditions are excluded to the fullest extent possible. No responsibility is assumed by Cirrus Logic for the use of information herein, including use of this information as the basis for manufacture or sale of any items, or for infringement of patents or other rights of third parties. Cirrus Logic, Cirrus, the Cirrus Logic logo design, and SoundClear are among the trademarks of Cirrus Logic. Other brand and product names may be trademarks or service marks of their respective owners.

Copyright © 2010–2016 Cirrus Logic, Inc. All rights reserved.

REVISION HISTORY

DATE	REV	DESCRIPTION OF CHANGES	PAGE	CHANGED BY
04/01/11	3.1	Order Info: updated to show both non tape and reel and tape and reel parts	9	JMacD
13/04/11	3.2	AVDD and CPVDD max voltage = 5V +5%	1,11	CT
21/12/16	4.0	Beep Generator added to Block Diagram Added Power Consumption Information	2 26	PH CT

Looking for pricing, stock, or lifecycle information?

Click below to explore more details on WIN SOURCE:

 [View WM8850GEFL/RV on WIN SOURCE](#)

 [Cirrus Logic Inc. Information](#)

Optimize Your Supply Chain with WIN SOURCE Solutions

-  Global Sourcing Solution
-  Obsolete Management
-  Cost Control Management
-  Shortage Management
-  Alternative Solution
-  Excess Inventory Management