



**THE DATASHEET OF
PI7AT04CEX**



**SOT1NY™ Low Voltage, Zero-Delay,
Active Transmission Line Clamp**
Features

- 5V and 3.3V Line Clamping
- Near Zero Quiescent Supply Current: 10 μ A Maximum
 - Active circuit clamping
- Low Capacitance: 5pF (typ.)
- High 4kV ESD Protection
- Packaging (Pb-free & Green Available):
 - 6-pin SC70 (C)

Benefits

- Reduced EMI
 - Limits high-frequency ring voltage
- Minimum Power Consumption
- Higher Noise Margin
- Minimal Line Loading

Applications

- CPU Termination
- Backplane Termination
- Termination

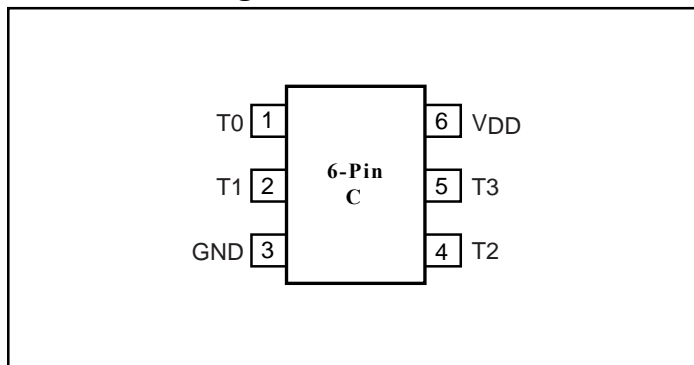
Product Pin Configuration

Description

The PI7AT04 actively clamps overshoot and undershoot voltages on transmission lines and backplanes. Improperly terminated data lines have reflections that can result in lost data or unreliable system behavior.

The PI7AT04 clamps undershoot and overshoot voltages for up to four lines. For other options and packages contact Pericom Marketing.

Compared to Schottky diodes, the PI7AT04 uses less power and requires no additional drive power. By avoiding a passive termination/clamp technology, PI7AT04 power consumption is very low at 5V.

The PI7AT04 is ideal in applications where characteristic impedance varies with system configuration. Changing characteristic impedance is common when memory or function cards are added or removed on a bus.

The PI7AT04 does not replace parallel terminator resistors.

Product Pin Description

| Pin Number | Name | Description |
|-------------|-----------------|-------------------------|
| 6-pin, SC70 | | |
| 1 | T0 | Line Termination |
| 2 | T1 | Line Termination |
| 4 | T2 | Line Termination |
| 5 | T3 | Line Termination |
| 3 | GND | Ground |
| 6 | V _{DD} | Positive Supply Voltage |

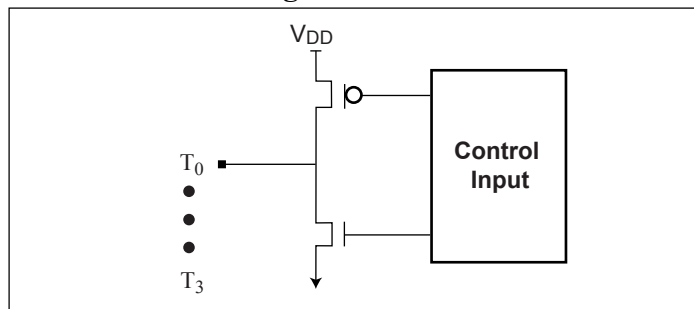
Functional Block Diagram

Absolute Maximum Ratings

| | |
|--|----------------|
| DC Voltage on Any Pin | 6.5V |
| Storage Temperature | -65°C to 150°C |
| Lead Temperature (Soldering, 10 seconds) | 300°C |
| Thermal Information | |
| MSOP Continuous Power Dissipation: derate 8.7mW/°C above 70°C) | 650mW |
| SC70/SOT23 Continuous Power Dissipation: derate 7.0mW/°C above 70°C) | 550mW |

Electrical Characteristics

$V_{DD} = 5V$ Over Operating Temperature Range, unless otherwise noted.

| Parameter | Symbol | Conditions | Temp | Min. | Typ | Max. | Units |
|------------------------------------|----------|---------------------------------------|------|------|------|------|---------|
| Line Signal Voltage Above V_{DD} | | Note 2 | | | 0.6 | | V |
| Line Signal Voltage Below GND | | Note 2 | | | -0.6 | | |
| Input Line Capacitance | C_I | Line Voltage = V_{DD} | 25 | | 5 | | pF |
| Input High Current | I_{IH} | $V_{LINE} = V_{DD}$, $V_{DD} = 5.5V$ | | | | 5 | μA |
| Input Low Current | I_{IL} | $V_{LINE} = 0V$, $V_{DD} = 5.5V$ | | | | 5 | |
| Supply Voltage Range | V_{DD} | | | 4.5 | | 5.5 | V |
| Quiescent Supply Current | I_{DD} | All lines floating | | | | 20 | μA |
| ESD Protection | | MIL-STD-883, Method 3015 | | | 4 | | kV |

$V_{DD} = 3.3V$ Over Operating Temperature Range, unless otherwise noted.

| Parameter | Symbol | Conditions | Temp | Min. | Typ. | Max. | Units |
|------------------------------------|----------|---------------------------------------|------|------|------|------|---------|
| Line Signal Voltage Above V_{DD} | | Note 2 | | | 0.6 | | V |
| Line Signal Voltage Below GND | | Note 2 | | | -0.6 | | |
| Input Line Capacitance | C_I | Line Voltage = V_{DD} | 25 | | 5 | | pF |
| Input High Current | I_{IH} | $V_{LINE} = V_{DD}$, $V_{DD} = 3.6V$ | | | | 3 | μA |
| Input Low Current | I_{IL} | $V_{LINE} = 0V$, $V_{DD} = 3.6V$ | | | | 3 | |
| Supply Voltage Range | V_{DD} | | | 3.0 | | 3.6 | V |
| Quiescent Supply Current | I_{DD} | All lines floating | | | | 20 | μA |
| ESD Protection | | MIL-STD-883, Method 3015 | | | 4 | | kV |

Notes:

1. Capacitance and ESD parameters are guaranteed by design.
2. Maximum line voltage clamped during a transient.

Application Information

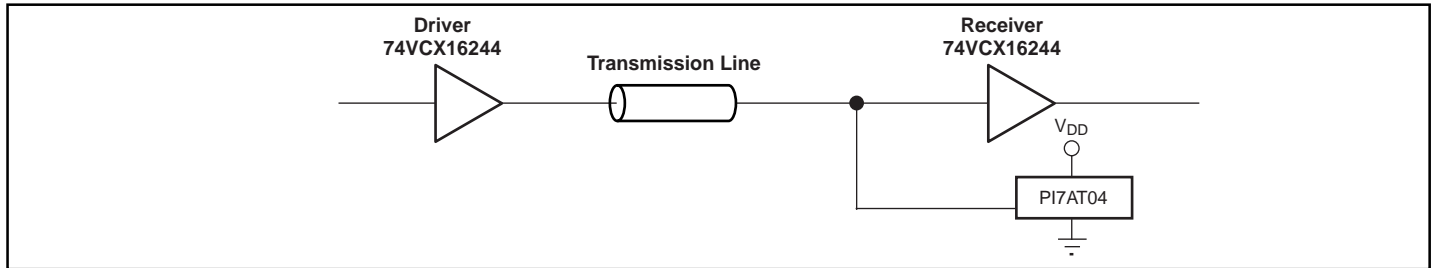

Figure 1. Test Diagram



Figure 2. VCX16244 (Vcc = 3.6V) output after driving 3-inch transmission line. Signal capture at end of line

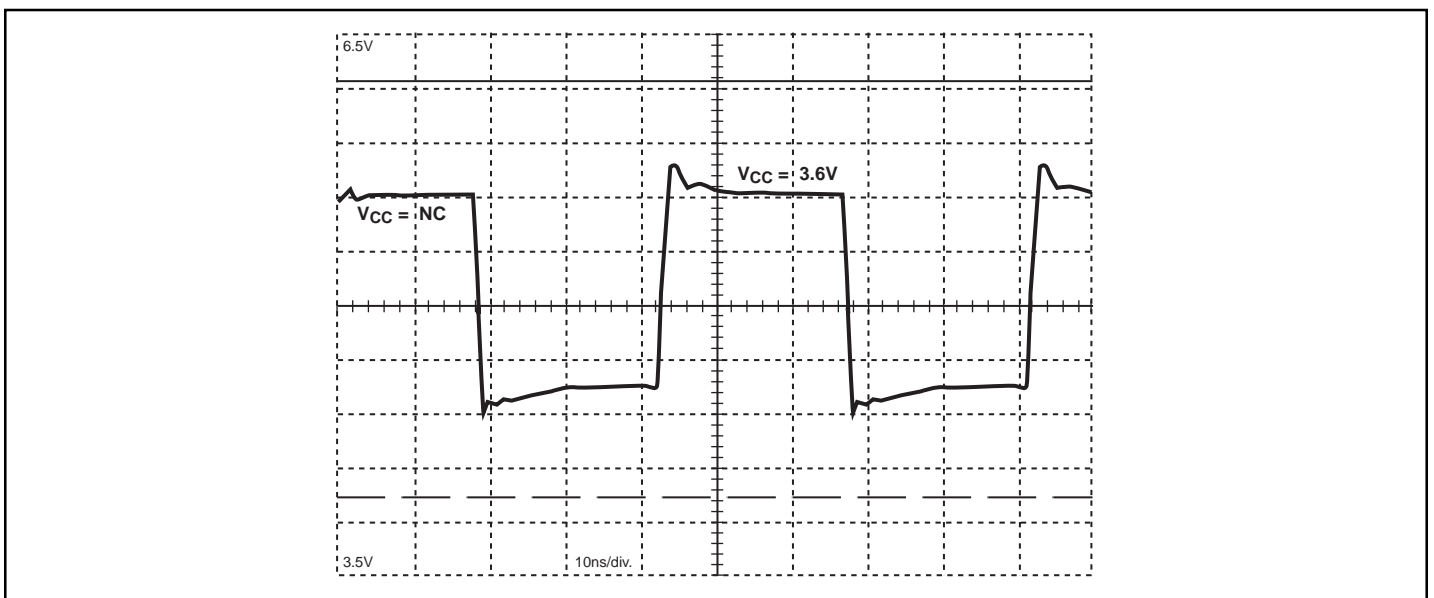

Figure 3. VCX16244 (Vcc = 3.6V) output after driving 3-inch transmission line and driving PI7AT04 input. Signal as seen at the input pin. Signal capture when Vcc in NC, Vcc = 3.6V.

Looking for pricing, stock, or lifecycle information?

Click below to explore more details on WIN SOURCE:

 [View PI7AT04CEX on WIN SOURCE](#)

 [Diodes Incorporated](#) Information

Optimize Your Supply Chain with WIN SOURCE Solutions

-  Global Sourcing Solution
-  Obsolete Management
-  Cost Control Management
-  Shortage Management
-  Alternative Solution
-  Excess Inventory Management