

**SINGLE CHANNEL:  
DUAL CHANNEL:**

**FOD070L  
FOD073L**

**FOD270L**

**DESCRIPTION**

The FOD070L, FOD270L and FOD073L optocouplers consist of an AlGaAs LED optically coupled to a high gain split darlington photodetector. These devices are specified to operate at a 3.3V supply voltage.

The split darlington configuration separating the input photodiode and the first stage gain from the output transistor permits lower output saturation voltage and higher speed operation than possible with conventional darlington phototransistor optocoupler. In the dual channel device FOD073L, an integrated emitter – base resistor provides superior stability over temperature.

The combination of a very low input current of 0.5 mA and a high current transfer ratio of 2000% makes this family particularly useful for input interface to MOS, CMOS, LSTTL and EIA RS232C, while output compatibility is ensured to LVCMOS as well as high fan-out LVTTTL requirements.

An internal noise shield provides exceptional common mode rejection of 10 kV/μs.

**FEATURES**

- Low power consumption
- Low input current - 0.5 mA
- Available in single channel 8-pin DIP (FOD270L), 8-pin SOIC (FOD070L) and dual channel 8-pin SOIC
- High CTR-2000%
- High CMR-10 kV/μs
- Guaranteed performance over temperature 0°C to 70°C
- U.L. recognized (File # E90700)
- LVTTTL/LVCMOS Compatible output

**APPLICATIONS**

- Digital logic ground isolation – LVTTTL/LVCMOS
- Telephone ring detector
- EIA-RS-232C line receiver
- High common mode noise line receiver
- μP bus isolation
- Current loop receiver

**TRUTH TABLE**

LED	V <sub>O</sub>
ON	LOW
OFF	HIGH

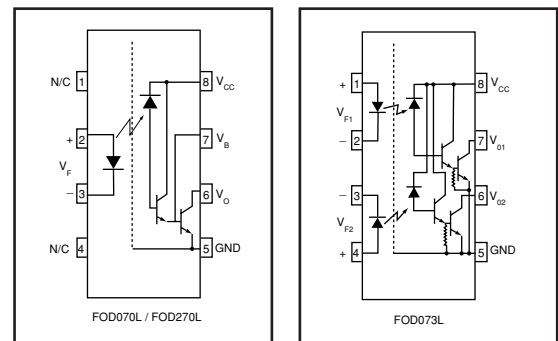
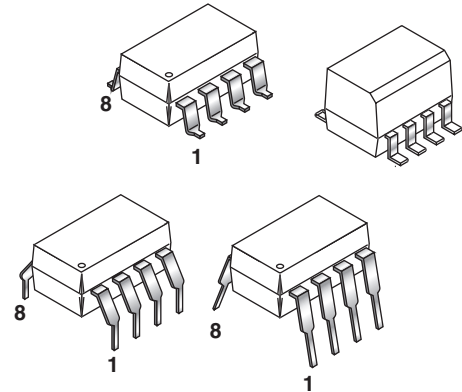

**SINGLE CHANNEL:  
DUAL CHANNEL:**

**FOD070L  
FOD073L**

**FOD270L**

**ABSOLUTE MAXIMUM RATINGS** (No derating required up to 85°C)

Parameter	Symbol	Value	Units
Storage Temperature	T <sub>STG</sub>	-40 to +125	°C
Operating Temperature	T <sub>OPR</sub>	-40 to +85	°C
Lead Solder Temperature (Wave solder only. See reflow profile for surface mount devices)	T <sub>SOL</sub>	260 for 10 sec	°C
<b>EMITTER</b>			
DC/Average Forward Input Current	I <sub>F</sub> (avg)	20	mA
Peak Forward Input Current (50% duty cycle, 1 ms P.W.)	I <sub>F</sub> (pk)	40	mA
Peak Transient Input Current - (≤1 μs P.W., 300 pps)	I <sub>F</sub> (trans)	1.0	A
Reverse Input Voltage	V <sub>R</sub>	5	V
Input Power Dissipation	P <sub>D</sub>	35	mW
<b>DETECTOR</b>			
Average Output Current	I <sub>O</sub> (avg)	60	mA
Emitter-Base Reverse Voltage (FOD070L, FOD270L)	V <sub>EB</sub>	0.5	V
Supply Voltage, Output Voltage	V <sub>CC</sub> , V <sub>O</sub>	-0.5 to 7	V
Output power dissipation	P <sub>D</sub>	100	mW

**ELECTRICAL CHARACTERISTICS** (T<sub>A</sub> = 0 to 70°C Unless otherwise specified)

**INDIVIDUAL COMPONENT CHARACTERISTICS**

Parameter	Test Conditions	Symbol	Device	Min	Typ**	Max	Unit
<b>EMITTER</b> Input Forward Voltage	T <sub>A</sub> = 25°C	V <sub>F</sub>	All		1.35	1.7	V
	Each Channel (I <sub>F</sub> = 1.6 mA)					1.75	
Input Reverse Breakdown Voltage	(T <sub>A</sub> = 25°C, I <sub>R</sub> = 10 μA) Each Channel	BV <sub>R</sub>	All	5.0			V
<b>DETECTOR</b> Logic high output current	(I <sub>F</sub> = 0 mA, V <sub>O</sub> = V <sub>CC</sub> = 3.3 V)	I <sub>OH</sub>	FOD070L FOD270L		0.05	25	μA
	Each Channel		FOD073L				
Logic Low Supply Current	I <sub>F</sub> = 1.6 mA, V <sub>O</sub> = Open, V <sub>CC</sub> = 3.3V	I <sub>CCL</sub>	FOD070L FOD270L		0.5	1.5	mA
	I <sub>F1</sub> = I <sub>F2</sub> = 1.6mA V <sub>O1</sub> = V <sub>O2</sub> = Open, V <sub>CC</sub> = 3.3 V		FOD073L		0.8	3	
Logic High Supply Current	I <sub>F</sub> = 0 mA, V <sub>O</sub> = Open, V <sub>CC</sub> = 3.3V	I <sub>CCH</sub>	FOD070L FOD270L		0.01	1	μA
	I <sub>F1</sub> = I <sub>F2</sub> = 0mA V <sub>O1</sub> = V <sub>O2</sub> = Open, V <sub>CC</sub> = 3.3 V		FOD073L		0.01	2	

\*\*All typicals at T<sub>A</sub> = 25°C

**SINGLE CHANNEL:**  
**DUAL CHANNEL:**

**FOD070L**  
**FOD073L**

**FOD270L**

**TRANSFER CHARACTERISTICS** ( $T_A = 0$  to  $70^\circ\text{C}$  Unless otherwise specified)

Parameter	Test Conditions	Symbol	Device	Min	Typ**	Max	Unit
<b>COUPLED</b> Current transfer ratio (Notes 1,2)	( $I_F = 0.5$ mA, $V_O = 0.4$ V, $V_{CC} = 3.3$ V)	CTR	ALL	400		7000	%
Logic low output voltage output voltage (Note 2)	( $I_F = 1.6$ mA, $I_O = 8$ mA, $V_{CC} = 3.3$ V)	$V_{OL}$	ALL		0.07	0.3	V
	( $I_F = 5$ mA, $I_O = 15$ mA, $V_{CC} = 3.3$ V)		ALL		0.07	0.4	

\*\*All typicals at  $T_A = 25^\circ\text{C}$

**SWITCHING CHARACTERISTICS** ( $T_A = 0$  to  $70^\circ\text{C}$  unless otherwise specified.,  $V_{CC} = 3.3$  V)

Parameter	Test Conditions	Symbol	Device	Min	Typ**	Max	Unit
Propagation delay time to logic low	( $R_L = 4.7$ k $\Omega$ , $I_F = 0.5$ mA) (Note 2) (Fig. 17)	$T_{PHL}$	FOD070L		3	30	$\mu\text{s}$
			FOD270L		5		
			FOD073L				
Propagation delay time to logic high	( $R_L = 4.7$ k $\Omega$ , $I_F = 0.5$ mA) (Note 2) (Fig. 17)	$T_{PLH}$	FOD070L		50	90	$\mu\text{s}$
			FOD270L		25		
			FOD073L				
Common mode transient immunity at logic high	( $I_F = 0$ mA, $ V_{CM}  = 10$ V <sub>P-P</sub> ) $T_A = 25^\circ\text{C}$ ( $R_L = 2.2$ k $\Omega$ ) (Note 3) (Fig. 18)	$ CM_H $	ALL	1,000	10,000		V/ $\mu\text{s}$
Common mode transient immunity at logic low	( $I_F = 1.6$ mA, $ V_{CM}  = 10$ V <sub>P-P</sub> , $R_L = 2.2$ k $\Omega$ ) $T_A = 25^\circ\text{C}$ (Note 3) (Fig. 18)	$ CM_L $	ALL	1,000	10,000		V/ $\mu\text{s}$

\*\* All typicals at  $T_A = 25^\circ\text{C}$

**SINGLE CHANNEL:  
DUAL CHANNEL:**

**FOD070L  
FOD073L**

**FOD270L**

**ISOLATION CHARACTERISTICS** ( $T_A = 0$  to  $70^\circ\text{C}$  Unless otherwise specified)

Characteristics	Test Conditions	Symbol	Device	Min	Typ**	Max	Unit
Input-output insulation leakage current	(Relative humidity = 45%) ( $T_A = 25^\circ\text{C}$ , $t = 5$ s) ( $V_{I-O} = 3000$ VDC) (Note 4)	$I_{I-O}$	ALL			1.0	$\mu\text{A}$
Withstand insulation test voltage	(RH $\leq$ 50%, $T_A = 25^\circ\text{C}$ ) (Note 4) ( $t = 1$ min.)	$V_{ISO}$	FOD070L FOD073L	2500			$V_{RMS}$
			FOD270L	5000			
Resistance (input to output)	(Note 4) ( $V_{I-O} = 500$ VDC)	$R_{I-O}$	ALL		$10^{12}$		$\Omega$
Capacitance (input to output)	(Note 4,5) ( $f = 1$ MHz)	$C_{I-O}$	ALL		0.7		pF
Input-Input Insulation leakage current	(RH $\leq$ 45%, $V_{I-I} = 500$ VDC (Note 6))	$I_{I-I}$	FOD073L	0.005			$\mu\text{A}$
Input-Input Resistance	( $V_{I-I} = 500$ VDC) (Note 6)	$R_{I-I}$	FOD073L		$10^{11}$		$\Omega$
Input-Input Capacitance	( $f = 1$ MHz) (Note 6)	$C_{I-I}$	FOD073L		0.03		pF

\*\* All typicals at  $T_A = 25^\circ\text{C}$

**NOTES**

1. Current Transfer Ratio is defined as a ratio of output collector current,  $I_O$ , to the forward LED input current,  $I_F$  times 100%.
2. Pin 7 open. (FOD070L and FOD270L only)
3. Common mode transient immunity in logic high level is the maximum tolerable (positive)  $dV_{CM}/dt$  on the leading edge of the common mode pulse signal,  $V_{CM}$ , to assure that the output will remain in a logic high state (i.e.,  $V_O > 2.0$  V). Common mode transient immunity in logic low level is the maximum tolerable (negative)  $dV_{CM}/dt$  on the trailing edge of the common mode pulse signal,  $V_{CM}$ , to assure that the output will remain in a logic low state (i.e.,  $V_O < 0.8$  V).
4. Device is considered a two terminal device: Pins 1, 2, 3 and 4 are shorted together and Pins 5, 6, 7 and 8 are shorted together.
5. For dual channel devices,  $C_{I-O}$  is measured by shorting pins 1 and 2 or pins 3 and 4 together and pins 5 through 8 shorted together.
6. Measured between pins 1 and 2 shorted together, and pins 3 and 4 shorted together.

**SINGLE CHANNEL:  
DUAL CHANNEL:**

**FOD070L  
FOD073L**

**FOD270L**

**TYPICAL PERFORMANCE CURVES**

**Fig. 1 Input Forward Current vs Forward Voltage**

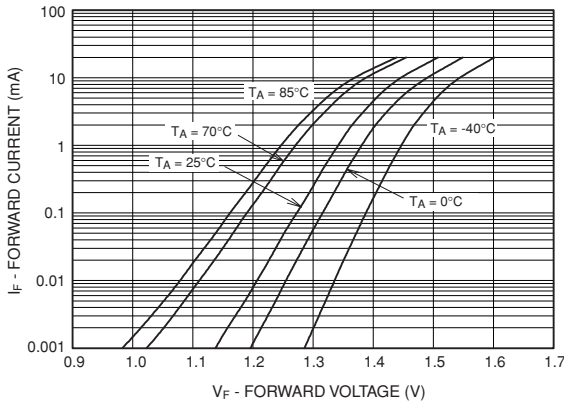

**Fig. 2 Current Transfer Ratio vs. Input Forward Current (FOD270L only)**

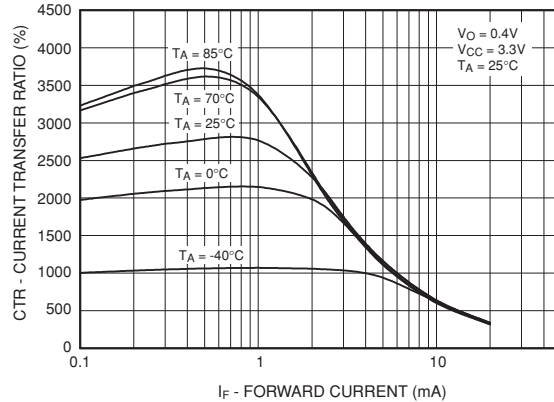

**Fig. 3 Current Transfer Ratio vs. Input Forward Current (FOD070L only)**

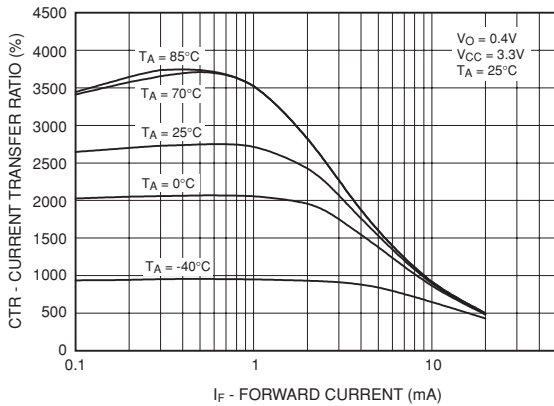

**Fig. 4 Current Transfer Ratio vs. Input Forward Current (FOD073L only)**

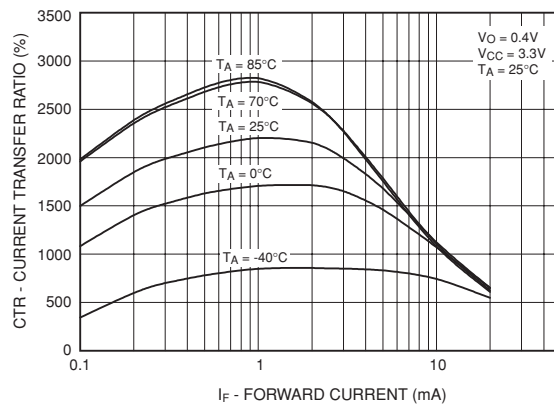

**Fig. 5 DC Transfer Characteristics (FOD070L, FOD270L)**

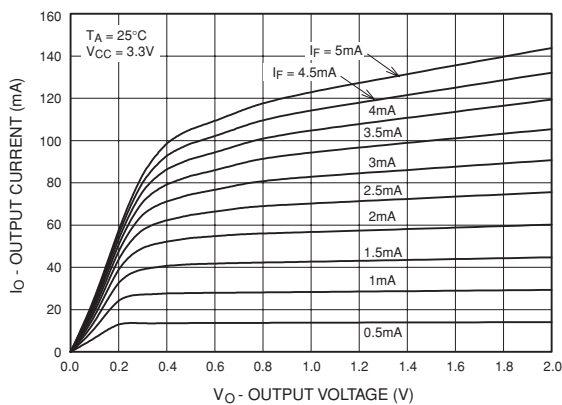

**Fig. 6 DC Transfer Characteristics (FOD073L only)**

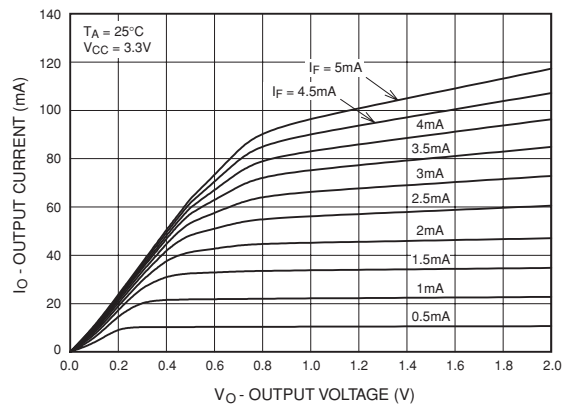

**SINGLE CHANNEL:  
DUAL CHANNEL:**

**FOD070L  
FOD073L**

**FOD270L**

**TYPICAL PERFORMANCE CURVES**

**Fig. 7 Supply Current vs Input Forward Current (FOD270L, FOD070L, FOD073L)**

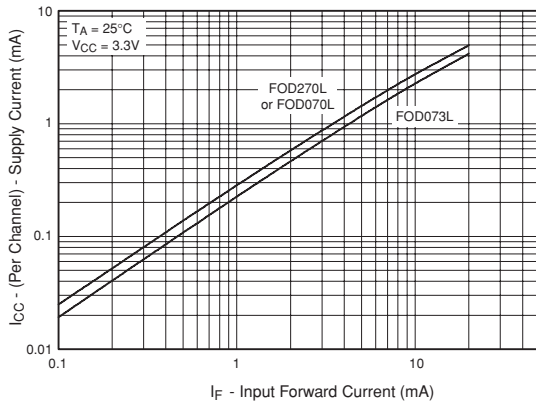

**Fig. 8 Output Current vs Input Forward Current (FOD270L only)**

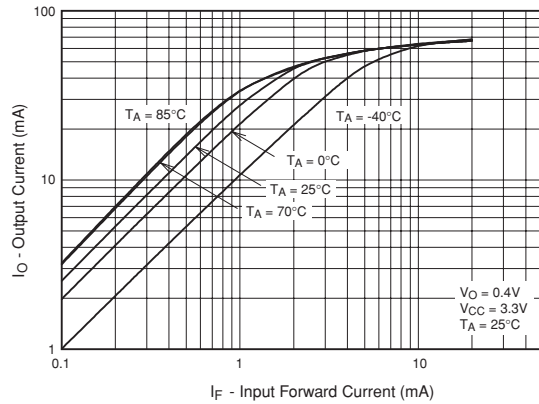

**Fig. 9 Output Current vs Input Forward Current (FOD070L only)**

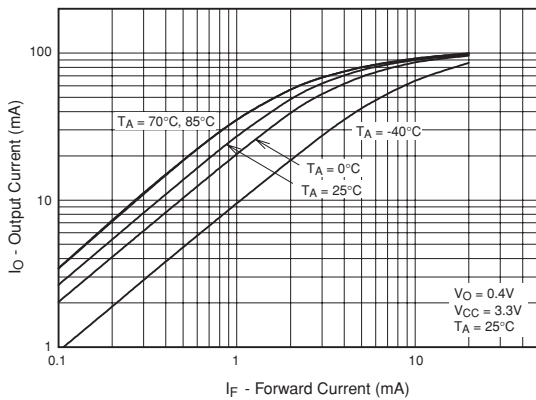

**Fig. 10 Output Current vs Input Forward Current (FOD073L only)**

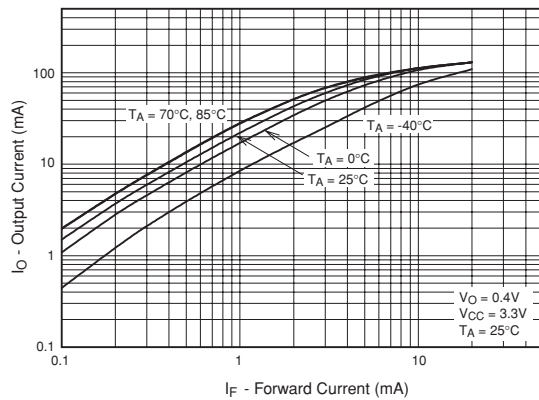

**Fig. 11 Propagation Delay vs. Input Forward Current (FOD070L only)**

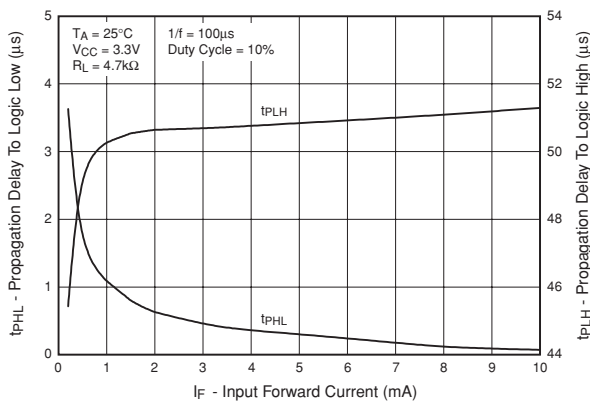

**Fig. 12 Propagation Delay vs. Ambient Temperature (FOD073L only)**

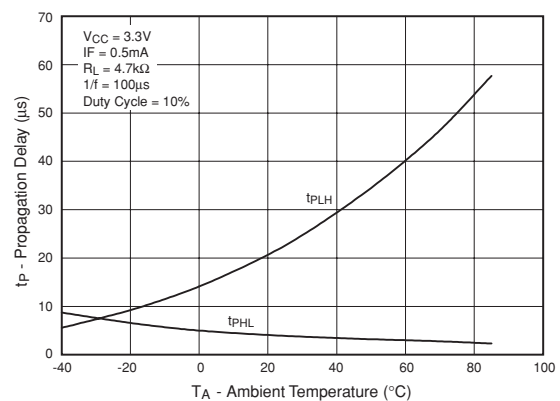

**SINGLE CHANNEL:  
DUAL CHANNEL:**

**FOD070L  
FOD073L**

**FOD270L**

**TYPICAL PERFORMANCE CURVES**

**Fig. 13 Propagation Delay vs. Ambient Temperature (FOD070L, FOD270L)**

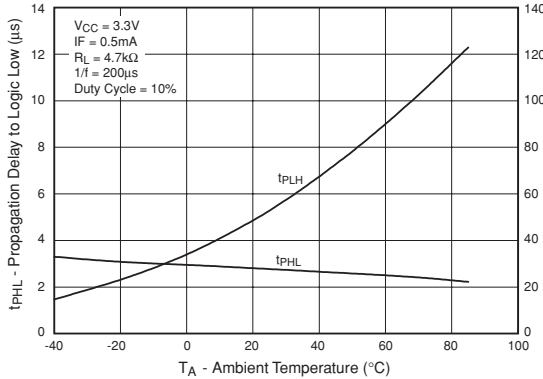

**Fig. 14 Propagation Delay To Logic Low vs Pulse Period (FOD073L, FOD070L, FOD270L)**

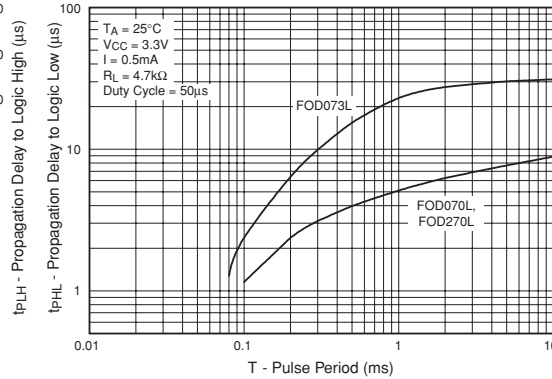

**Fig. 15 Propagation Delay vs. Input Forward Current (FOD270L only)**

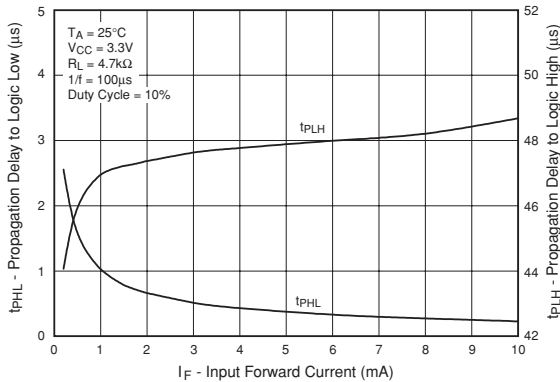

**Fig. 16 Propagation Delay vs. Input Forward Current (FOD073L only)**

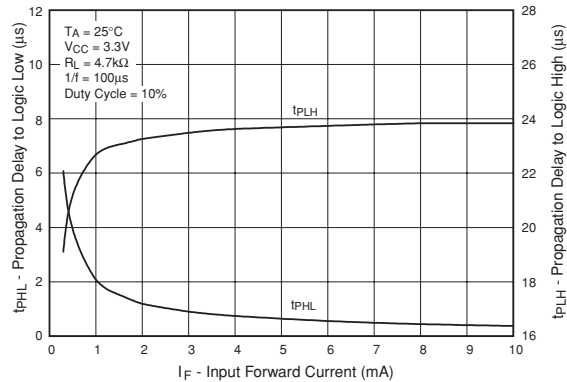

**SINGLE CHANNEL:  
DUAL CHANNEL:**

**FOD070L  
FOD073L**

**FOD270L**

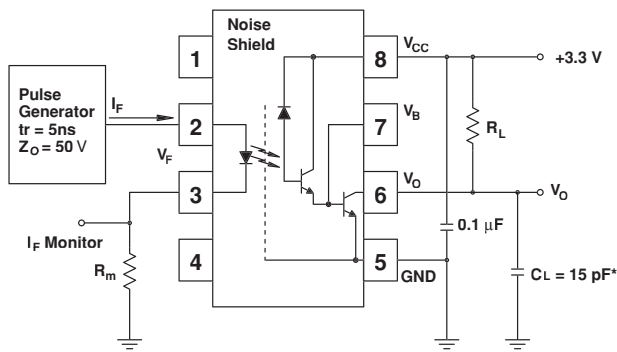

Test Circuit for FOD070L, FOD270L

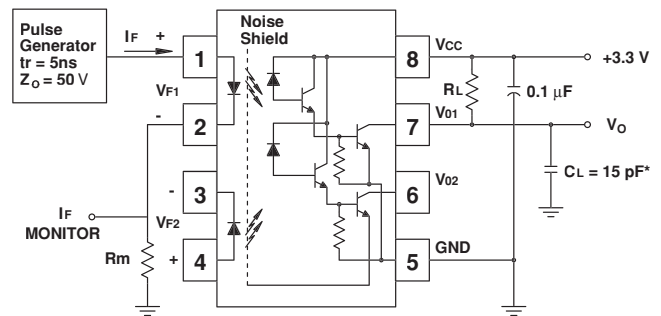

Test Circuit for FOD073L

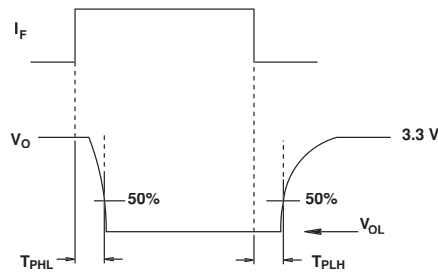

\*Includes Probe and Fixture Capacitance

**Fig. 17 Switching Time Test Circuit**

**SINGLE CHANNEL:  
DUAL CHANNEL:**

**FOD070L  
FOD073L**

**FOD270L**

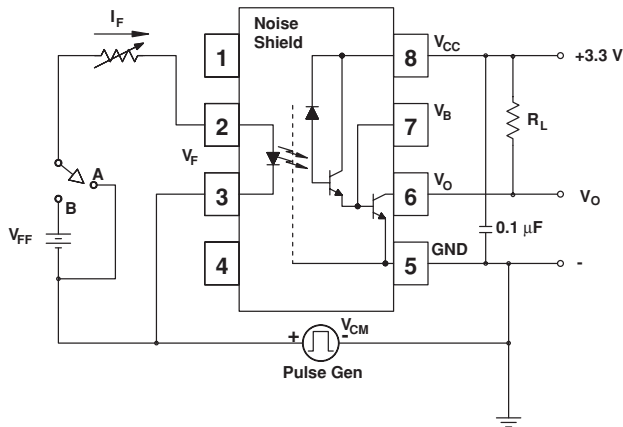

Test Circuit for FOD070L and FOD270L

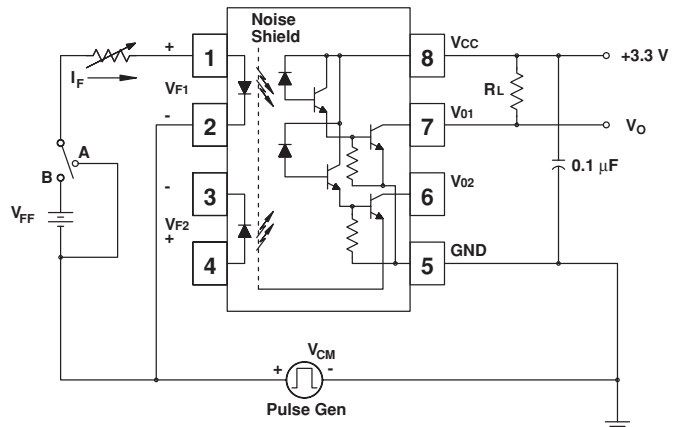

Test Circuit for FOD073L

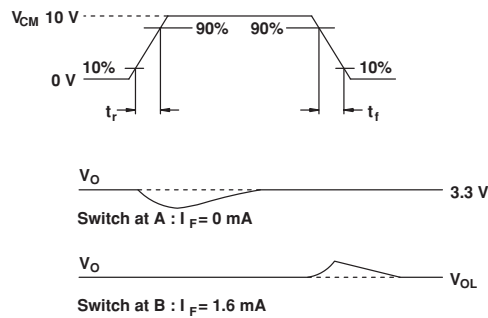

**Fig. 18 Common Mode Immunity Test Circuit**



**SINGLE CHANNEL:  
DUAL CHANNEL:**

**FOD070L  
FOD073L**

**FOD270L**

**SOIC 8**

**Package Dimensions (Surface Mount)**

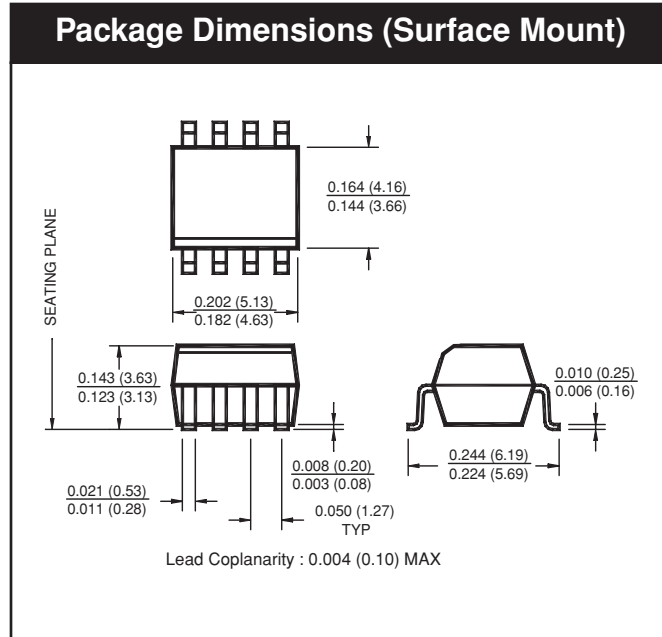

**Recommend Pad Layout**

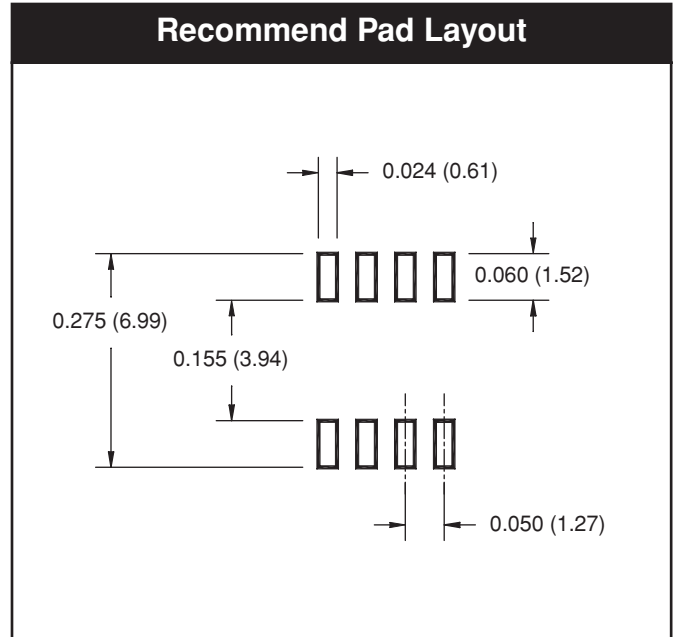

**SINGLE CHANNEL:  
DUAL CHANNEL:**

**FOD070L  
FOD073L**

**FOD270L**

**ORDERING INFORMATION**

Option	Order Entry Identifier	Description
S	FOD270LS	Surface Mount Lead Bend (DIP Package Only)
SD	FOD270LSD	Surface Mount; Tape and reel (DIP Package Only) (1000 units per reel)
SV	Pending approval	Surface Mount; VDE 0884 (DIP Package Only)
SDV	Pending approval	Surface Mount; Tape and reel (DIP Package Only); VDE 0884 (1000 units per reel)
T	FOD270LT	0.4" lead spacing (DIP Package Only)
TV	Pending approval	0.4" lead spacing, VDE 0884 (DIP Package Only)
R1	FOD070LR1	Tape and reel (500 units per reel) (SOIC 8 Package only)
R1V	Pending approval	VDE, Tape and reel (500 units per reel) (SOIC 8 Package only)
R2	FOD070LR2	Tape and reel (2500 units per reel) (SOIC 8 Package only)
R2V	Pending approval	VDE 0884, Tape and reel (2500 units per reel) (SOIC 8 Package only)
V	Pending approval	VDE 0884

**MARKING INFORMATION (FOD070L, FOD073L)**

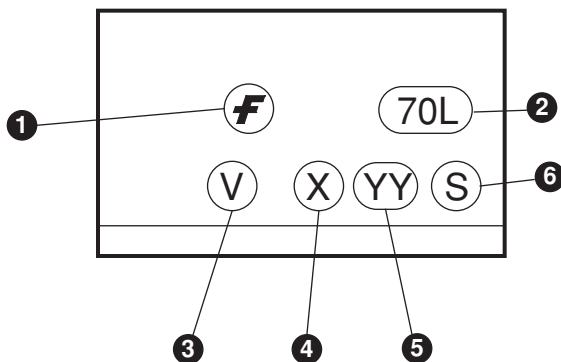

Definitions	
1	Fairchild logo
2	Device number
3	VDE mark (Note: Only appears on parts ordered with VDE option – See order entry table)
4	One digit year code, e.g., '3'
5	Two digit work week ranging from '01' to '53'
6	Assembly package code

**SINGLE CHANNEL:  
DUAL CHANNEL:**

**FOD070L  
FOD073L**

**FOD270L**

**MARKING INFORMATION (FOD270L)**

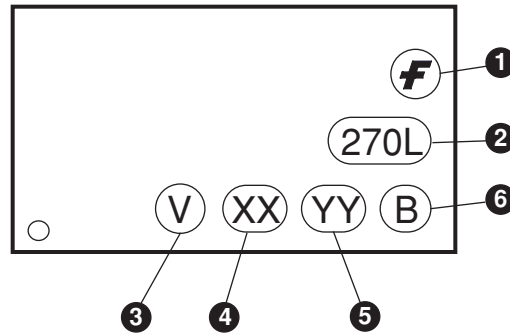

Definitions	
1	Fairchild logo
2	Device number
3	VDE mark (Note: Only appears on parts ordered with VDE option – See order entry table)
4	Two digit year code, e.g., '03'
5	Two digit work week ranging from '01' to '53'
6	Assembly package code

**SINGLE CHANNEL:  
DUAL CHANNEL:**

**FOD070L  
FOD073L**

**FOD270L**

**Carrier Tape Specifications (FOD070L and FOD073L)**

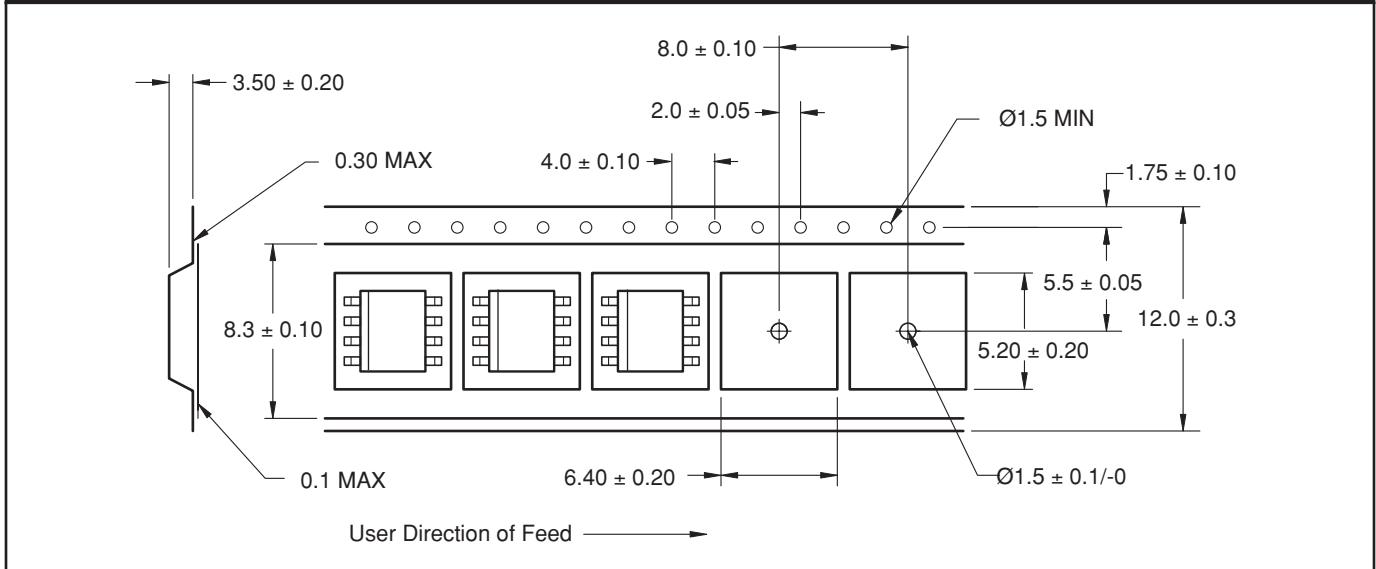

**SINGLE CHANNEL:  
DUAL CHANNEL:**

**FOD070L  
FOD073L**

**FOD270L**

**Carrier Tape Specifications (FOD270L)**

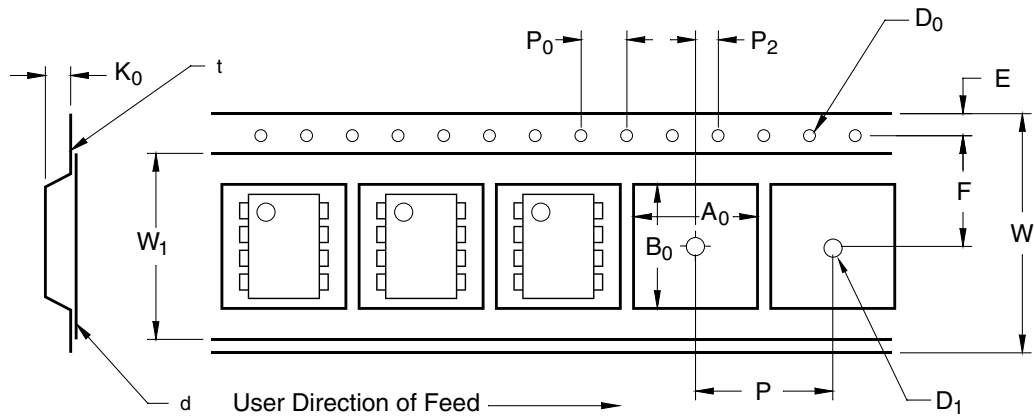

Description	Symbol	Dimension in mm
Tape Width	W	16.0 ± 0.3
Tape Thickness	t	0.30 ± 0.05
Sprocket Hole Pitch	P <sub>0</sub>	4.0 ± 0.1
Sprocket Hole Diameter	D <sub>0</sub>	1.55 ± 0.05
Sprocket Hole Location	E	1.75 ± 0.10
Pocket Location	F	7.5 ± 0.1
	P <sub>2</sub>	4.0 ± 0.1
Pocket Pitch	P	12.0 ± 0.1
Pocket Dimensions	A <sub>0</sub>	10.30 ± 0.20
	B <sub>0</sub>	10.30 ± 0.20
	K <sub>0</sub>	4.90 ± 0.20
Cover Tape Width	W <sub>1</sub>	1.6 ± 0.1
Cover Tape Thickness	d	0.1 max
Max. Component Rotation or Tilt		10°
Min. Bending Radius	R	30

**SINGLE CHANNEL:  
DUAL CHANNEL:**

**FOD070L  
FOD073L**

**FOD270L**

**Reflow Profile (FOD070L and FOD073L)**

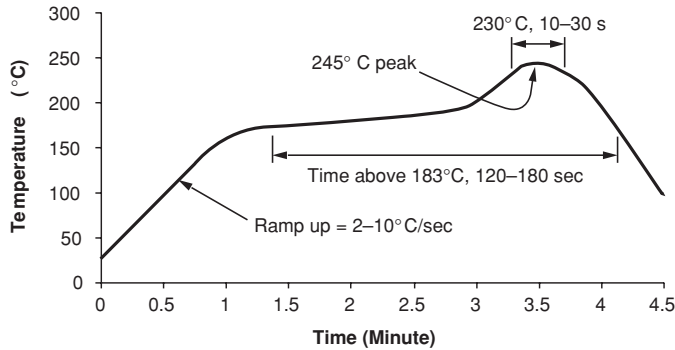

- Peak reflow temperature: 245°C (package surface temperature)
- Time of temperature higher than 183°C for 120-180 seconds
- One time soldering reflow is recommended

**Reflow Profile (FOD270L)**

- Peak reflow temperature: 260°C (package surface temperature)
- Time of temperature higher than 245°C: 40 seconds or less
- Number of reflows: Three

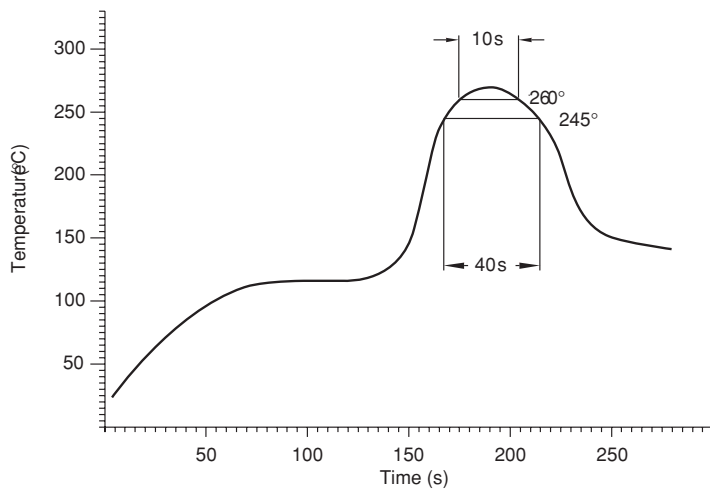

---

**SINGLE CHANNEL:  
DUAL CHANNEL:**

**FOD070L  
FOD073L**

**FOD270L**

---

**DISCLAIMER**

FAIRCHILD SEMICONDUCTOR RESERVES THE RIGHT TO MAKE CHANGES WITHOUT FURTHER NOTICE TO ANY PRODUCTS HEREIN TO IMPROVE RELIABILITY, FUNCTION OR DESIGN. FAIRCHILD DOES NOT ASSUME ANY LIABILITY ARISING OUT OF THE APPLICATION OR USE OF ANY PRODUCT OR CIRCUIT DESCRIBED HEREIN; NEITHER DOES IT CONVEY ANY LICENSE UNDER ITS PATENT RIGHTS, NOR THE RIGHTS OF OTHERS.

**LIFE SUPPORT POLICY**

FAIRCHILD'S PRODUCTS ARE NOT AUTHORIZED FOR USE AS CRITICAL COMPONENTS IN LIFE SUPPORT DEVICES OR SYSTEMS WITHOUT THE EXPRESS WRITTEN APPROVAL OF THE PRESIDENT OF FAIRCHILD SEMICONDUCTOR CORPORATION. As used herein:

1. Life support devices or systems are devices or systems which, (a) are intended for surgical implant into the body, or (b) support or sustain life, and (c) whose failure to perform when properly used in accordance with instructions for use provided in the labeling, can be reasonably expected to result in a significant injury of the user.
2. A critical component in any component of a life support device or system whose failure to perform can be reasonably expected to cause the failure of the life support device or system, or to affect its safety or effectiveness.

## Looking for pricing, stock, or lifecycle information?

Click below to explore more details on WIN SOURCE:

- ⊖ [View FOD070LR2 on WIN SOURCE](#)
- ⊖ [Fairchild/ON Semiconductor Information](#)

## Optimize Your Supply Chain with WIN SOURCE Solutions

- ✓ Global Sourcing Solution
- ✓ Obsolete Management
- ✓ Cost Control Management
- ✓ Shortage Management
- ✓ Alternative Solution
- ✓ Excess Inventory Management