



**THE DATASHEET OF
LM5111-2MY/NOPB**



LM5111 Dual 5-A Compound Gate Driver

1 Features

- Independently Drives Two N-Channel MOSFETs
- Compound CMOS and Bipolar Outputs Reduce Output Current Variation
- 5-A Sink and 3-A Source Current Capability
- Two Channels can be Connected in Parallel to Double the Drive Current
- Independent Inputs (TTL Compatible)
- Fast Propagation Times (25 ns Typical)
- Fast Rise and Fall Times (14 ns and 12 ns Rise and Fall, Respectively, With 2-nF Load)
- Available in Dual Noninverting, Dual Inverting and Combination Configurations
- Supply Rail Undervoltage Lockout Protection (UVLO)^f
- LM5111-4 UVLO Configured to Drive PFET through OUT_A and NFET through OUT_B
- Pin Compatible With Industry Standard Gate Drivers

2 Applications

- Synchronous Rectifier Gate Drivers
- Switch-mode Power Supply Gate Driver
- Solenoid and Motor Drivers

3 Description

The LM5111 Dual Gate Driver replaces industry standard gate drivers with improved peak output current and efficiency. Each *compound* output driver stage includes MOS and bipolar transistors operating in parallel that together sink more than 5-A peak from capacitive loads. Combining the unique characteristics of MOS and bipolar devices reduces drive current variation with voltage and temperature. Undervoltage lockout protection is also provided. The drivers can be operated in parallel with inputs and outputs connected to double the drive current capability. This device is available in the SOIC package or the thermally enhanced MSOP-PowerPAD package.

Device Information⁽¹⁾

PART NUMBER	PACKAGE	BODY SIZE (NOM)
LM5111	SOIC (8)	5.00 mm x 6.00 mm
	MSOP-PowerPAD (8)	3.00 mm x 4.90 mm

(1) For all available packages, see the orderable addendum at the end of the data sheet.

Simplified Application Diagram

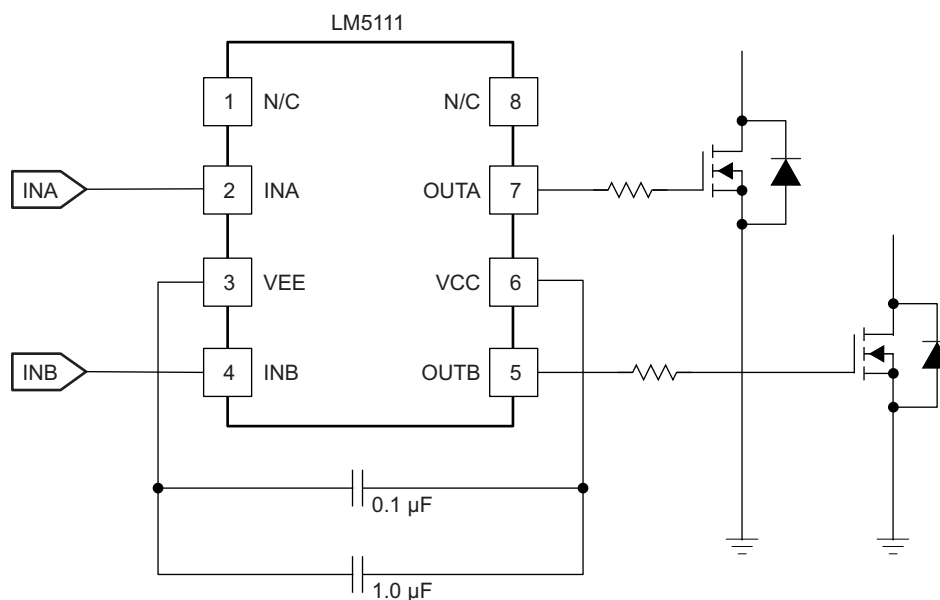

Copyright © 2016, Texas Instruments Incorporated



Table of Contents

1 Features	1	8.4 Device Functional Modes.....	10
2 Applications	1	9 Application and Implementation	11
3 Description	1	9.1 Application Information.....	11
4 Revision History	2	9.2 Typical Application	11
5 Device Options	3	10 Power Supply Recommendations	13
6 Pin Configuration and Functions	3	10.1 Bias Supply Voltage.....	13
7 Specifications	4	11 Layout	13
7.1 Absolute Maximum Ratings	4	11.1 Layout Guidelines	13
7.2 ESD Ratings.....	4	11.2 Layout Example	14
7.3 Recommended Operating Conditions.....	4	11.3 Thermal Considerations.....	14
7.4 Thermal Information	4	12 Device and Documentation Support	17
7.5 Electrical Characteristics.....	5	12.1 Receiving Notification of Documentation Updates	17
7.6 Switching Characteristics	5	12.2 Community Resources.....	17
7.7 Typical Characteristics	7	12.3 Trademarks	17
8 Detailed Description	9	12.4 Electrostatic Discharge Caution.....	17
8.1 Overview	9	12.5 Glossary	17
8.2 Functional Block Diagram	9	13 Mechanical, Packaging, and Orderable	17
8.3 Feature Description.....	10	Information	17

4 Revision History

NOTE: Page numbers for previous revisions may differ from page numbers in the current version.

Changes from Revision G (March 2013) to Revision H	Page
<ul style="list-style-type: none"> Added <i>Device Information</i> table, <i>Pin Configuration and Functions</i> section, <i>Specifications</i> section, <i>ESD Ratings</i> table, <i>Recommended Operating Conditions</i> table, <i>Thermal Information</i> table, <i>Feature Description</i> section, <i>Device Functional Modes</i> section, <i>Application and Implementation</i> section, <i>Power Supply Recommendations</i> section, <i>Layout</i> section, <i>Device and Documentation Support</i> section, and <i>Mechanical, Packaging, and Orderable Information</i> section 	1

Changes from Revision F (March 2013) to Revision G	Page
<ul style="list-style-type: none"> Changed layout of National Semiconductor Data Sheet to TI format 	16

5 Device Options

Table 1. Configuration Table

PART NUMBER	"A" OUTPUT CONFIGURATION	"B" OUTPUT CONFIGURATION	PACKAGE
LM5111-1M/-1MX/-1MY/-1MYX	Noninverting (Low in UVLO)	Noninverting (Low in UVLO)	SOIC, MSOP-PowerPAD
LM5111-2M/-2MX/-2MY/-2MYX	Inverting (Low in UVLO)	Inverting (Low in UVLO)	SOIC, MSOP-PowerPAD
LM5111-3M/-3MX/-3MY/-3MYX	Inverting (Low in UVLO)	Noninverting (Low in UVLO)	SOIC, MSOP-PowerPAD
LM5111-4M/-4MX/-4MY/-4MYX	Inverting (High in UVLO)	Noninverting (Low in UVLO)	SOIC, MSOP-PowerPAD

6 Pin Configuration and Functions

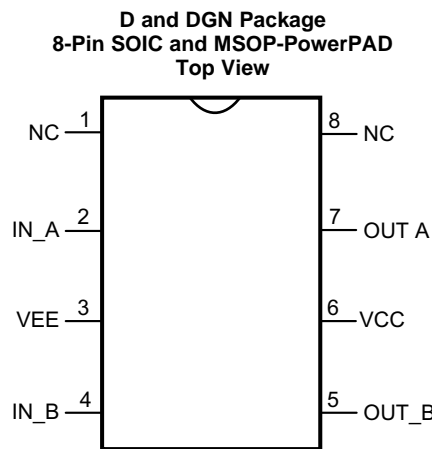

Pin Functions

PIN		I/O	DESCRIPTION
NAME	NO.		
IN_A	2	I	'A' side control input. TTL compatible thresholds.
IN_B	4	I	'B' side control input. TTL compatible thresholds.
OUT_A	7	O	Output for the 'A' side driver. Voltage swing of this output is from VCC to VEE. The output stage is capable of sourcing 3 A and sinking 5 A.
OUT_B	5	O	Output for the 'B' side driver. Voltage swing of this output is from VCC to VEE. The output stage is capable of sourcing 3 A and sinking 5 A.
VCC	6	—	Positive output supply. Locally decouple to VEE.
VEE	3	—	Ground reference for both inputs and outputs. Connect to power ground.
NC	1, 8	—	No Connection
Exposed Pad ⁽¹⁾		—	It is recommended that the exposed pad on the bottom of the package be soldered to ground plane on the PC board to aid thermal dissipation.

(1) Only available with the MSOP-PowerPAD package.

7 Specifications

7.1 Absolute Maximum Ratings

 see ⁽¹⁾⁽²⁾

	MIN	MAX	UNIT
VCC to VEE	–0.3	15	V
IN to VEE	–0.3	15	V
Maximum junction temperature, $T_J(\text{max})$		150	°C
Storage temperature, T_{stg}	–55	150	°C

- (1) Stresses beyond those listed under *Absolute Maximum Ratings* may cause permanent damage to the device. These are stress ratings only, which do not imply functional operation of the device at these or any other conditions beyond those indicated under *Recommended Operating Conditions*. Exposure to absolute-maximum-rated conditions for extended periods may affect device reliability.
- (2) If Military/Aerospace specified devices are required, please contact the Texas Instruments Sales Office/Distributors for availability and specifications.

7.2 ESD Ratings

	VALUE	UNIT
V_{ESD} Electrostatic discharge Human-body model (HBM), per ANSI/ESDA/JEDEC JS-001 ⁽¹⁾	2000	V

- (1) JEDEC document JEP155 states that 500-V HBM allows safe manufacturing with a standard ESD control process.

7.3 Recommended Operating Conditions

over operating free-air temperature range (unless otherwise noted)

	MIN	NOM	MAX	UNIT
T_J Operating junction temperature			125	°C

7.4 Thermal Information

THERMAL METRIC ⁽¹⁾	LM5111		UNIT
	D (SOIC)	DGN (MSOP-PowerPAD)	
	8 PINS	8 PINS	
$R_{\theta\text{JA}}$ Junction-to-ambient thermal resistance	112.2	50.7	°C/W
$R_{\theta\text{JC}(\text{top})}$ Junction-to-case (top) thermal resistance	54.6	56.6	°C/W
$R_{\theta\text{JB}}$ Junction-to-board thermal resistance	53.1	35.9	°C/W
Ψ_{JT} Junction-to-top characterization parameter	9.4	5.3	°C/W
Ψ_{JB} Junction-to-board characterization parameter	52.5	35.6	°C/W
$R_{\theta\text{JC}(\text{bot})}$ Junction-to-case (bottom) thermal resistance	N/A	4.4	°C/W

- (1) For more information about traditional and new thermal metrics, see the *Semiconductor and IC Package Thermal Metrics* application report.

7.5 Electrical Characteristics

$T_J = -40^{\circ}\text{C}$ to $+125^{\circ}\text{C}$, $V_{CC} = 12\text{ V}$, $V_{EE} = 0\text{ V}$, No Load on OUT_A or OUT_B, unless otherwise specified.

PARAMETER		TEST CONDITIONS	MIN	TYP	MAX	UNIT
V_{CC} operating range		$V_{CC}-V_{EE}$	3.5		14	V
V_{CCR}	V_{CC} undervoltage lockout (rising)	$V_{CC}-V_{EE}$	2.3	2.9	3.5	V
V_{CCH}	V_{CC} undervoltage lockout hysteresis			230		mV
I_{CC}	V_{CC} supply current (I_{CC})	IN_A = IN_B = 0 V (5111-1)		1	2	mA
		IN_A = IN_B = V_{CC} (5111-2)		1	2	
		IN_A = V_{CC} , IN_B = 0 V (5111-3)		1	2	
CONTROL INPUTS						
V_{IH}	Logic high		2.2			V
V_{IL}	Logic low				0.8	V
V_{thH}	High threshold		1.3	1.75	2.2	V
V_{thL}	Low threshold		0.8	1.35	2	V
HYS	Input hysteresis			400		mV
I_{iL}	Input current low	IN_A=IN_B= V_{CC} (5111-1-2-3)	-1	0.1	1	μA
I_{iH}	Input current high	IN_B= V_{CC} (5111-3)	10	18	25	
		IN_A=IN_B= V_{CC} (5111-2)	-1	0.1	1	
		IN_A=IN_B= V_{CC} (5111-1)	10	18	25	
		IN_A= V_{CC} (5111-3)	-1	0.1	1	
OUTPUT DRIVERS						
R_{OH}	Output resistance high	$I_{OUT} = -10\text{ mA}^{(1)}$		30	50	Ω
R_{OL}	Output resistance low	$I_{OUT} = +10\text{ mA}^{(1)}$		1.4	2.5	Ω
I_{Source}	Peak source current	OUTA/OUTB = $V_{CC}/2$, 200-ns Pulsed Current		3		A
I_{Sink}	Peak sink current	OUTA/OUTB = $V_{CC}/2$, 200-ns Pulsed Current		5		A
LATCHUP PROTECTION						
AEC - Q100, method 004		$T_J = 150^{\circ}\text{C}$		500		mA
THERMAL RESISTANCE						
θ_{JA}	Junction to ambient, 0 LFPM air flow	SOIC Package		170		$^{\circ}\text{C}/\text{W}$
		MSOP-PowerPAD Package		60		
θ_{JC}	Junction to case	SOIC Package		70		$^{\circ}\text{C}/\text{W}$
		MSOP-PowerPAD Package		4.7		

(1) The output resistance specification applies to the MOS device only. The total output current capability is the sum of the MOS and Bipolar devices.

7.6 Switching Characteristics

over operating free-air temperature range (unless otherwise noted)

PARAMETER		TEST CONDITIONS	MIN	TYP	MAX	UNIT
td1	Propagation delay time low to high, IN rising (IN to OUT)	$C_{LOAD} = 2\text{ nF}^{(1)}$		25	40	ns
td2	Propagation delay time high to low, IN falling (IN to OUT)	$C_{LOAD} = 2\text{ nF}^{(1)}$		25	40	ns
t_r	Rise time	$C_{LOAD} = 2\text{ nF}^{(1)}$		14	25	ns
t_f	Fall time	$C_{LOAD} = 2\text{ nF}^{(1)}$		12	25	ns

(1) See [Figure 1](#) and [Figure 2](#).

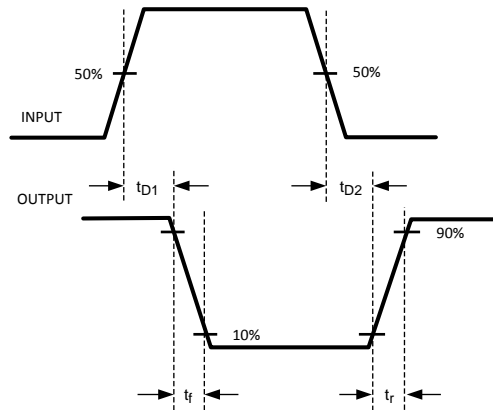

Figure 1. Inverting

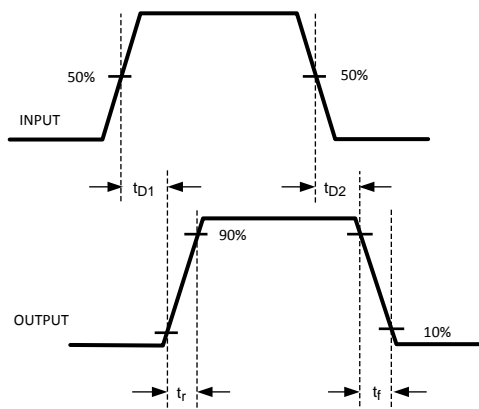

Figure 2. Noninverting

7.7 Typical Characteristics

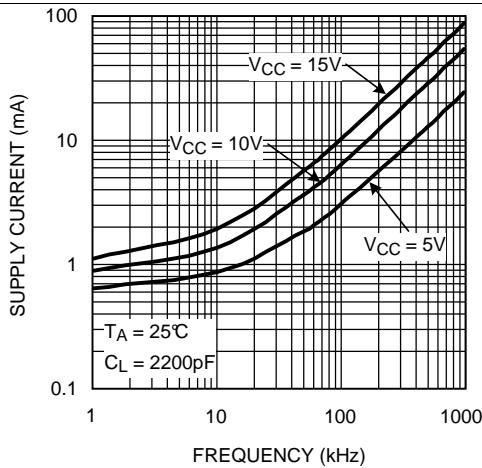

Figure 3. Supply Current vs Frequency

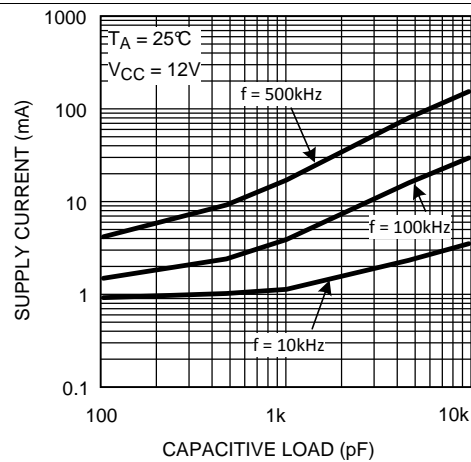

Figure 4. Supply Current vs Capacitive Load

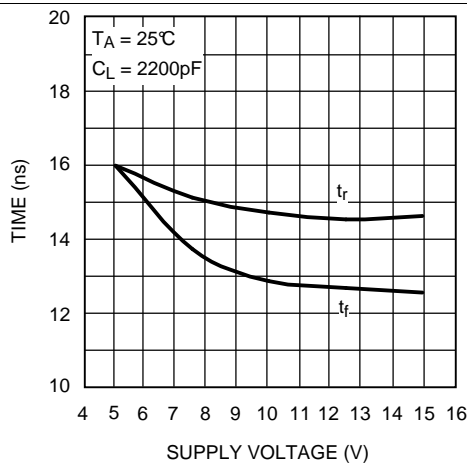

Figure 5. Rise and Fall Time vs Supply Voltage

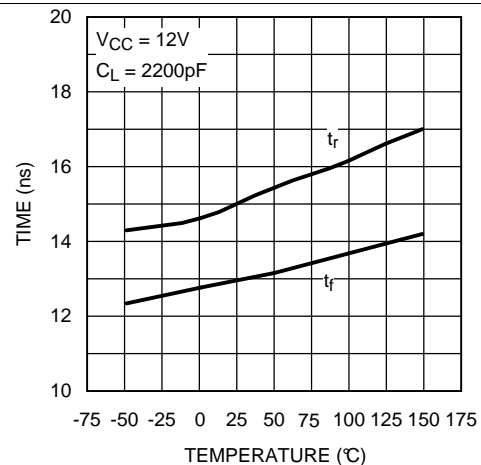

Figure 6. Rise and Fall Time vs Temperature

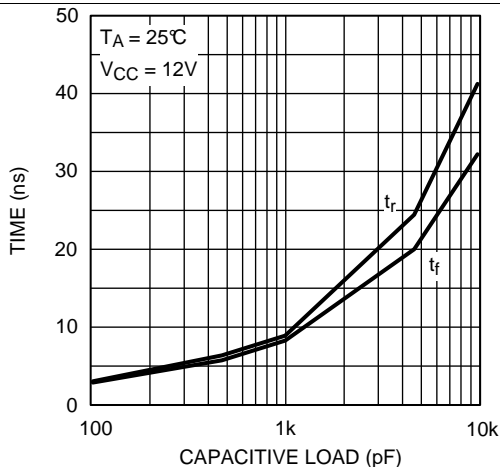

Figure 7. Rise and Fall Time vs Capacitive Load

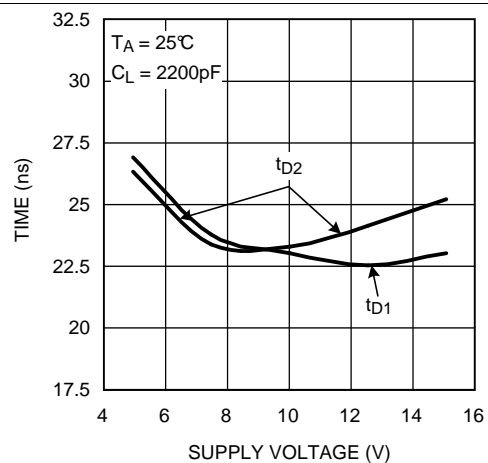
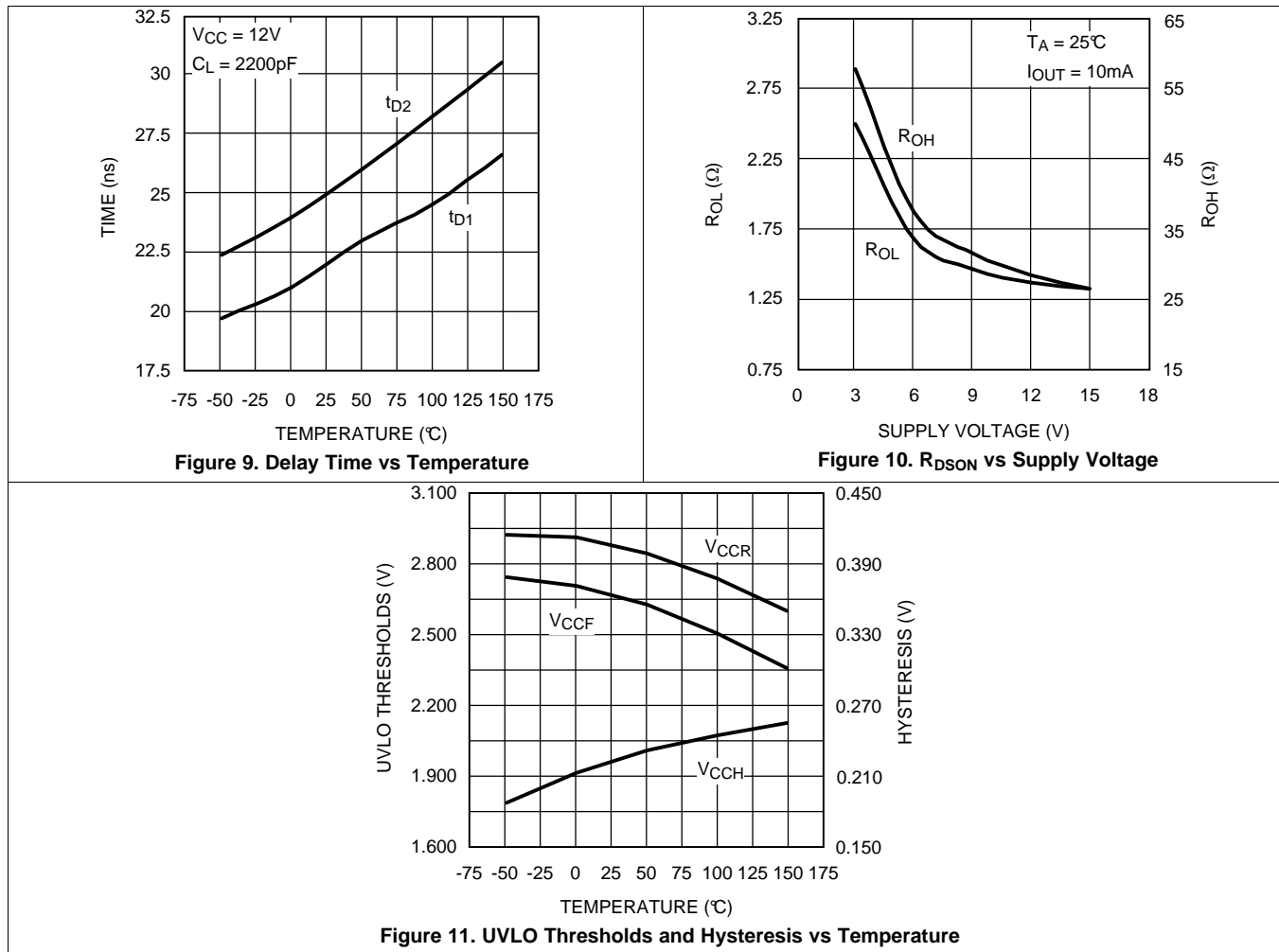

Figure 8. Delay Time vs Supply Voltage

Typical Characteristics (continued)



8 Detailed Description

8.1 Overview

LM5111 dual gate driver consists of two independent and identical driver channels with TTL compatible logic inputs and high current totem-pole outputs that source or sink current to drive MOSFET gates. The driver output consist of a compound structure with MOS and bipolar transistor operating in parallel to optimize current capability over a wide output voltage and operating temperature range. The bipolar device provides high peak current at the critical threshold region of the MOSFET VGS while the MOS devices provide rail-to-rail output swing. The totem pole output drives the MOSFET gate between the gate drive supply voltage V_{CC} and the power ground potential at the V_{EE} pin.

The control inputs of the drivers are high impedance CMOS buffers with TTL compatible threshold voltages. The LM5111 pinout was designed for compatibility with industry standard gate drivers in single supply gate driver applications.

The input stage of each driver should be driven by a signal with a short rise and fall time. Slow rising and falling input signals, although not harmful to the driver, may result in the output switching repeatedly at a high frequency.

8.2 Functional Block Diagram

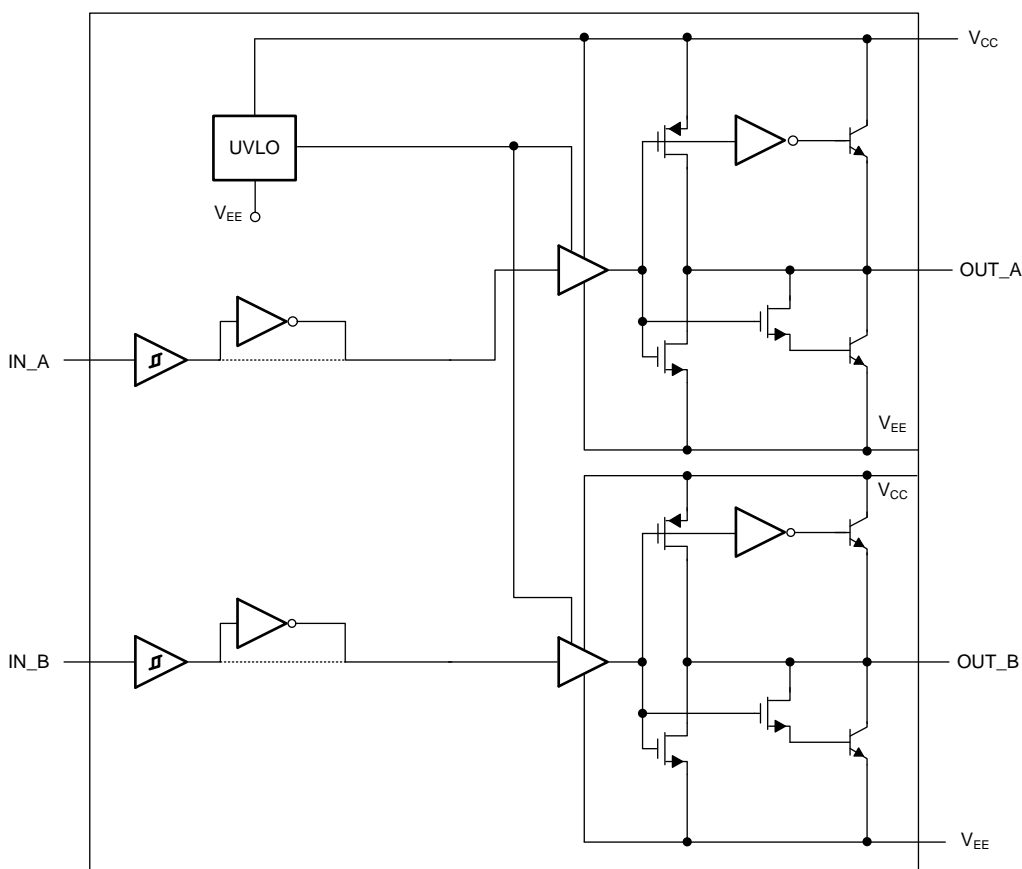

Copyright © 2016, Texas Instruments Incorporated

8.3 Feature Description

8.3.1 Undervoltage Lockout

An undervoltage lockout (UVLO) circuit is included in the LM5111, which senses the voltage difference between V_{CC} and the chip ground pin, V_{EE} . When the V_{CC} to V_{EE} voltage difference falls below 2.8 V both driver channels are disabled. The UVLO hysteresis prevents chattering during brown-out conditions and the driver resumes normal operation when the V_{CC} to V_{EE} differential voltage exceeds approximately 3 V.

The LM5111-1, -2, and -3 devices hold both outputs in the low state in the UVLO condition. The LM5111-4 is distinguished from the LM5111-3 by the active high output state of OUT_A during UVLO. When V_{CC} is less than the UVLO threshold voltage, OUT_A of the LM5111-4 will be locked in the high state while OUT_B will be disabled in the low state. This configuration allows the LM5111-4 to drive a PFET through OUT_A and an NFET through OUT_B with both FETs safely turned off during UVLO.

8.3.2 Output Stage

The two driver channels of the LM5111 are designed as identical cells. Transistor matching inherent to integrated circuit manufacturing ensures that the AC and DC performance of the channels are nearly identical. Closely matched propagation delays allow the dual driver to be operated as a single with inputs and output pins connected. The drive current capability in parallel operation is precisely 2x the drive of an individual channel. Small differences in switching speed between the driver channels will produce a transient current (shoot-through) in the output stage when two output pins are connected to drive a single load. Differences in input thresholds between the driver channels will also produce a transient current (shoot-through) in the output stage. Fast transition input signals are especially important while operating in a parallel configuration. The efficiency loss for parallel operation has been characterized at various loads, supply voltages and operating frequencies. The power dissipation in the LM5111 increases by less than 1% relative to the dual driver configuration when operated as a single driver with inputs/ outputs connected.

8.4 Device Functional Modes

Table 2. Input/output Logic Table

LM5111-1M				LM5111-2M				LM5111-3M/LM5111-4M			
IN A	IN B	OUT A	OUT B	IN A	IN B	OUT A	OUT B	IN A	IN B	OUT A	OUT B
L	L	L	L	L	L	H	H	L	L	H	L
L	H	L	H	L	H	H	L	L	H	H	H
H	L	H	L	H	L	L	H	H	L	L	L
H	H	H	H	H	H	L	L	H	H	L	H
In UVLO		L	L	In UVLO		L	L	In UVLO		L/H	L/L

9 Application and Implementation

NOTE

Information in the following applications sections is not part of the TI component specification, and TI does not warrant its accuracy or completeness. TI's customers are responsible for determining suitability of components for their purposes. Customers should validate and test their design implementation to confirm system functionality.

9.1 Application Information

High-frequency power supplies often require high-speed, high-current drivers such as the LM5111 family. A leading application is the need to provide a high-power buffer stage between the PWM output of the control IC and the gates of the primary power MOSFET or IGBT switching devices. In other cases, the driver IC is used to drive the power-device gates through a drive transformer. Synchronous rectification supplies are also needed to simultaneously drive multiple devices which presents an extremely large load to the control circuitry.

Driver ICs are used when use of the primary PWM regulator IC to directly drive the switching devices for one or more reasons is not feasible. The PWMIC does not have the brute drive capability required for the intended switching MOSFET, limiting the switching performance in the application. In other cases, there may be a desire to minimize the effect of high-frequency switching noise by placing the high current driver physically close to the load. Also, newer ICs that target the highest operating frequencies do not incorporate onboard gate drivers at all. Their PWM outputs are only intended to drive the high impedance input to a driver such as the UCCx732x. Finally, the control IC is under thermal stress due to power dissipation, and an external driver helps by moving the heat from the controller to an external package.

9.2 Typical Application

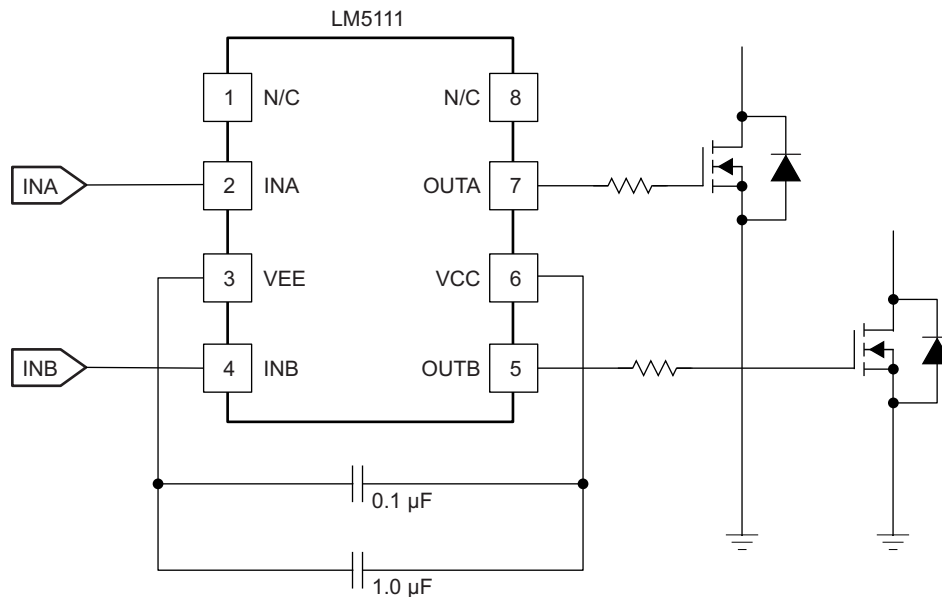

Copyright © 2016, Texas Instruments Incorporated

Figure 12. LM5111 Driving Two Independent MOSFETs

9.2.1 Design Requirements

To select the proper device from the LM5111 family, TI recommends first checking the appropriate logic for the outputs. LM5111 has dual inverting outputs; dual noninverting outputs; inverting channel A and noninverting channel B. Refer to operating modes to select which driver from the family is required in a given application. Moreover, some design considerations must be evaluated first in order to make the most appropriate selection. Among these considerations are VCC and power dissipation.

Typical Application (continued)

9.2.2 Detailed Design Procedure

9.2.2.1 VCC

Although quiescent VCC current is very low, total supply current will be higher, depending on OUTA and OUTB current and the programmed oscillator frequency. Total VCC current is the sum of quiescent VCC current and the average OUT current. Knowing the operating frequency and the MOSFET gate charge (Q_g), average OUT current can be calculated using Equation 1.

$$I_{OUT} = Q_g \times f$$

where

- f is frequency

(1)

For the best high-speed circuit performance, two VCC bypass capacitors are recommended to prevent noise problems. The use of surface mount components is highly recommended. A 0.1- μ F ceramic capacitor should be located closest to the VDD to ground connection. In addition, a larger capacitor (such as 1 μ F and above) with relatively low ESR should be connected in parallel, to help deliver the high current peaks to the load. The parallel combination of capacitors should present a low impedance characteristic for the expected current levels in the driver application.

9.2.3 Application Curves

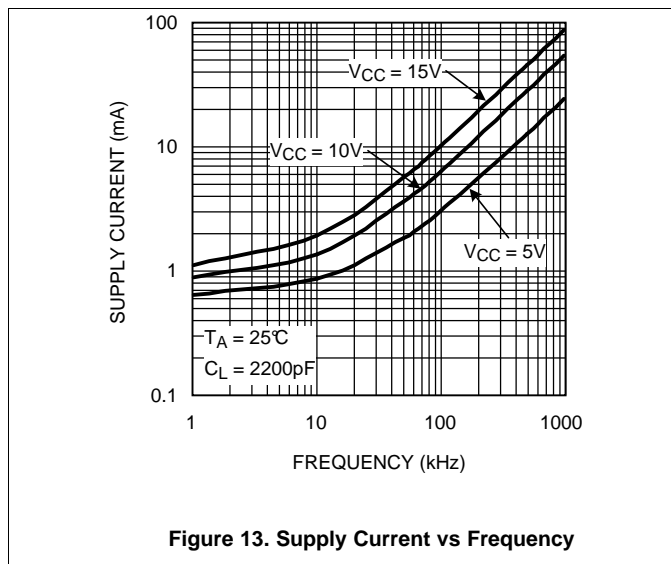

Figure 13. Supply Current vs Frequency

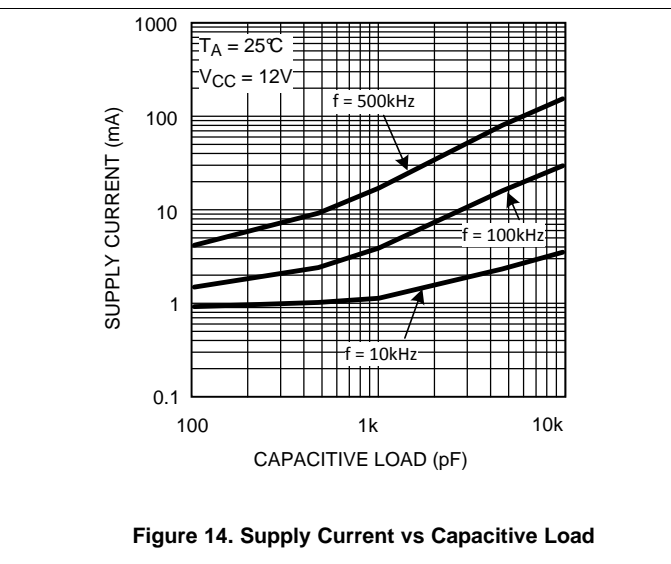

Figure 14. Supply Current vs Capacitive Load

10 Power Supply Recommendations

10.1 Bias Supply Voltage

The recommended bias supply voltage range for LM5111 is from 3.5 V to 14 V. The upper end of this range is driven by the 15-V absolute maximum voltage rating of the VCC. TI recommends keeping proper margin to allow for transient voltage spikes. A local bypass capacitor must be placed between the VCC and VEE pins, and this capacitor must be placed as close to the device as possible. TI recommends a low ESR, ceramic surface mount capacitor. TI recommends using 2 capacitors across VCC and VEE: a 100-nF ceramic surface-mount capacitor for high frequency filtering placed very close to VCC and VEE pin, and another surface-mount capacitor, 220 nF to 10 μ F, for IC bias requirements.

11 Layout

11.1 Layout Guidelines

Attention must be given to board layout when using LM5111. Some important considerations include:

- A Low ESR/ESL capacitor must be connected close to the IC and between the V_{CC} and V_{EE} pins to support high peak currents being drawn from V_{CC} during turnon of the MOSFET.
- Proper grounding is crucial. The drivers need a very low impedance path for current return to ground avoiding inductive loops. The two paths for returning current to ground are a) between LM5111 V_{EE} pin and the ground of the circuit that controls the driver inputs, b) between LM5111 V_{EE} pin and the source of the power MOSFET being driven. All these paths should be as short as possible to reduce inductance and be as wide as possible to reduce resistance. All these ground paths should be kept distinctly separate to avoid coupling between the high current output paths and the logic signals that drive the LM5111. A good method is to dedicate one copper plane in a multi-layered PCB to provide a common ground surface.
- With the rise and fall times in the range of 10 ns to 30 ns, care is required to minimize the lengths of current carrying conductors to reduce their inductance and EMI from the high di/dt transients generated by the LM5111.
- The LM5111 footprint is compatible with other industry standard drivers including the TC4426/27/28 and UCC27323/4/5.
- If either channel is not being used, the respective input pin (IN_A or IN_B) should be connected to either V_{EE} or V_{CC} to avoid spurious output signals.

11.2 Layout Example

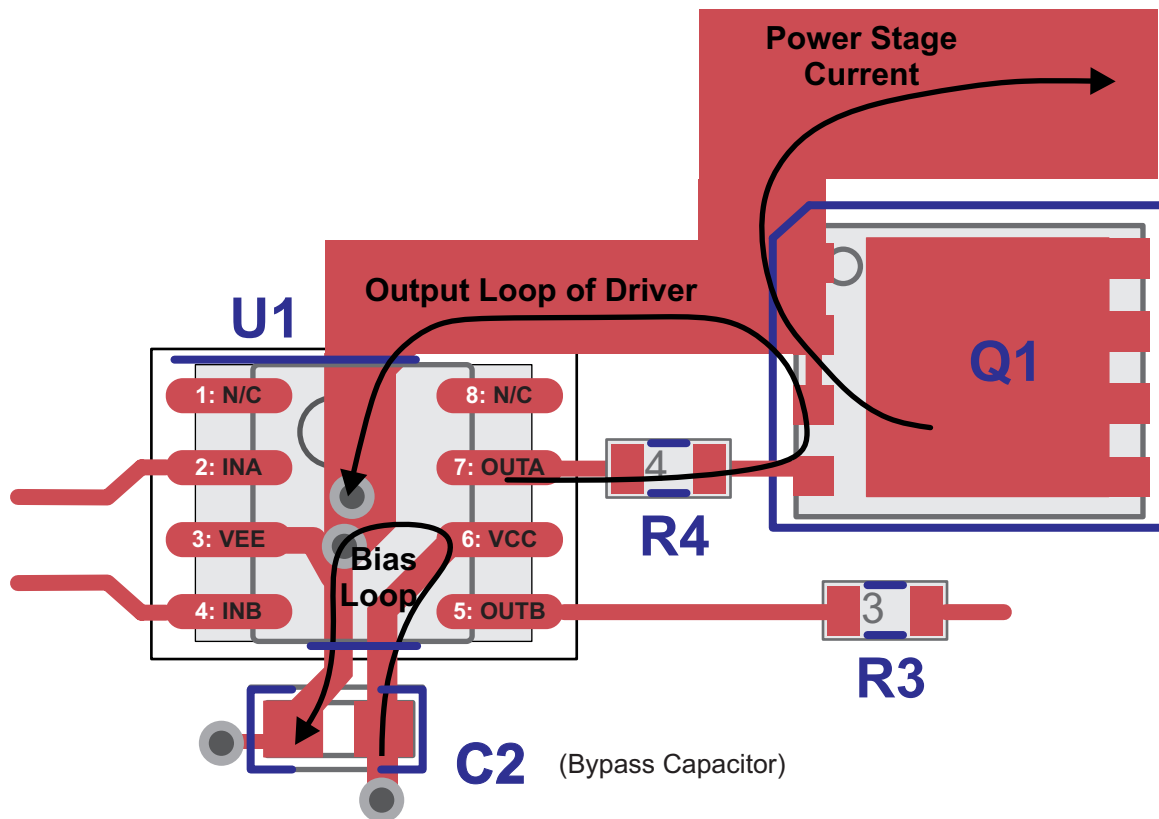

Figure 15. Layout

11.3 Thermal Considerations

The primary goal of thermal management is to maintain the integrated circuit (IC) junction temperature (T_J) below a specified maximum operating temperature to ensure reliability. It is essential to estimate the maximum T_J of IC components in worst case operating conditions. The junction temperature is estimated based on the power dissipated in the IC and the junction to ambient thermal resistance θ_{JA} for the IC package in the application board and environment. The θ_{JA} is not a given constant for the package and depends on the printed circuit board design and the operating environment.

11.3.1 Drive Power Requirement Calculations in LM5111

The LM5111 dual low side MOSFET driver is capable of sourcing/sinking 3A/5A peak currents for short intervals to drive a MOSFET without exceeding package power dissipation limits. High peak currents are required to switch the MOSFET gate very quickly for operation at high frequencies.

Thermal Considerations (continued)

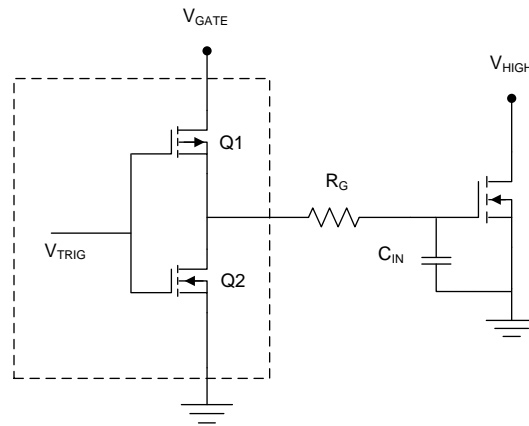

Figure 16. Driver Output Stage and Load

The schematic above shows a conceptual diagram of the LM5111 output and MOSFET load. Q1 and Q2 are the switches within the gate driver. R_G is the gate resistance of the external MOSFET, and C_{IN} is the equivalent gate capacitance of the MOSFET. The gate resistance R_G is usually very small and losses in it can be neglected. The equivalent gate capacitance is a difficult parameter to measure since it is the combination of C_{GS} (gate to source capacitance) and C_{GD} (gate to drain capacitance). Both of these MOSFET capacitances are not constants and vary with the gate and drain voltage. The better way of quantifying gate capacitance is the total gate charge Q_G in coulombs. Q_G combines the charge required by C_{GS} and C_{GD} for a given gate drive voltage V_{GATE} .

Assuming negligible gate resistance, the total power dissipated in the MOSFET driver due to gate charge is approximated by

$$P_{DRIVER} = V_{GATE} \times Q_G \times F_{SW}$$

where

- F_{SW} = switching frequency of the MOSFET (2)

For example, consider the MOSFET MTD6N15 whose gate charge specified as 30 nC for $V_{GATE} = 12$ V.

The power dissipation in the driver due to charging and discharging of MOSFET gate capacitances at switching frequency of 300 kHz and V_{GATE} of 12 V is equal to

$$P_{DRIVER} = 12 \text{ V} \times 30 \text{ nC} \times 300 \text{ kHz} = 0.108 \text{ W.} \quad (3)$$

If both channels of the LM5111 are operating at equal frequency with equivalent loads, the total losses will be twice as this value which is 0.216 W.

In addition to the above gate charge power dissipation, transient power is dissipated in the driver during output transitions. When either output of the LM5111 changes state, current will flow from V_{CC} to V_{EE} for a very brief interval of time through the output totem-pole N and P channel MOSFETs. The final component of power dissipation in the driver is the power associated with the quiescent bias current consumed by the driver input stage and Under-voltage lockout sections.

Characterization of the LM5111 provides accurate estimates of the transient and quiescent power dissipation components. At 300-kHz switching frequency and 30-nC load used in the example, the transient power will be 8 mW. The 1-mA nominal quiescent current and 12-V V_{GATE} supply produce a 12-mW typical quiescent power.

Therefore the total power dissipation

$$P_D = 0.216 + 0.008 + 0.012 = 0.236 \text{ W.} \quad (4)$$

We know that the junction temperature is given by

$$T_J = P_D \times \theta_{JA} + T_A \quad (5)$$

Thermal Considerations (continued)

Or the rise in temperature is given by

$$T_{\text{RISE}} = T_J - T_A = P_D \times \theta_{JA} \quad (6)$$

For SOIC package, θ_{JA} is estimated as 170°C/W for the conditions of natural convection. For MSOP-PowerPAD, θ_{JA} is typically 60°C/W.

Therefore for SOIC T_{RISE} is equal to

$$T_{\text{RISE}} = 0.236 \times 170 = 40.1^\circ\text{C} \quad (7)$$

11.3.2 Continuous Current Rating of LM5111

The LM5111 can deliver pulsed source/sink currents of 3 A and 5 A to capacitive loads. In applications requiring continuous load current (resistive or inductive loads), package power dissipation, limits the LM5111 current capability far below the 5-A sink and 3-A source capability. Rated continuous current can be estimated both when sourcing current to or sinking current from the load. For example when sinking, the maximum sink current can be calculated as:

$$I_{\text{SINK (MAX)}} := \sqrt{\frac{T_J(\text{MAX}) - T_A}{\theta_{JA} \cdot R_{DS(\text{ON})}}}$$

where

- $R_{DS(\text{on})}$ is the on resistance of lower MOSFET in the output stage of LM5111 (8)

Consider $T_J(\text{max})$ of 125°C and θ_{JA} of 170°C/W for an SO-8 package under the condition of natural convection and no air flow. If the ambient temperature (T_A) is 60°C, and the $R_{DS(\text{on})}$ of the LM5111 output at $T_J(\text{max})$ is 2.5 Ω , this equation yields $I_{\text{SINK}(\text{max})}$ of 391 mA which is much smaller than 5-A peak pulsed currents.

Similarly, the maximum continuous source current can be calculated as

$$I_{\text{SOURCE (MAX)}} := \frac{T_J(\text{MAX}) - T_A}{\theta_{JA} \cdot V_{\text{DIODE}}}$$

where

- V_{DIODE} is the voltage drop across hybrid output stage which varies over temperature and can be assumed to be about 1.1 V at $T_J(\text{max})$ of 125°C (9)

Assuming the same parameters as above, this equation yields $I_{\text{SOURCE}(\text{max})}$ of 347 mA.

12 Device and Documentation Support

12.1 Receiving Notification of Documentation Updates

To receive notification of documentation updates, navigate to the device product folder on ti.com. In the upper right corner, click on *Alert me* to register and receive a weekly digest of any product information that has changed. For change details, review the revision history included in any revised document.

12.2 Community Resources

The following links connect to TI community resources. Linked contents are provided "AS IS" by the respective contributors. They do not constitute TI specifications and do not necessarily reflect TI's views; see TI's [Terms of Use](#).

TI E2E™ Online Community *TI's Engineer-to-Engineer (E2E) Community*. Created to foster collaboration among engineers. At e2e.ti.com, you can ask questions, share knowledge, explore ideas and help solve problems with fellow engineers.

Design Support *TI's Design Support* Quickly find helpful E2E forums along with design support tools and contact information for technical support.

12.3 Trademarks

E2E is a trademark of Texas Instruments.
All other trademarks are the property of their respective owners.

12.4 Electrostatic Discharge Caution



These devices have limited built-in ESD protection. The leads should be shorted together or the device placed in conductive foam during storage or handling to prevent electrostatic damage to the MOS gates.

12.5 Glossary

[SLYZ022](#) — *TI Glossary*.

This glossary lists and explains terms, acronyms, and definitions.

13 Mechanical, Packaging, and Orderable Information

The following pages include mechanical, packaging, and orderable information. This information is the most current data available for the designated devices. This data is subject to change without notice and revision of this document. For browser-based versions of this data sheet, refer to the left-hand navigation.

PACKAGING INFORMATION

Orderable Device	Status (1)	Package Type	Package Drawing	Pins	Package Qty	Eco Plan (2)	Lead finish/ Ball material (6)	MSL Peak Temp (3)	Op Temp (°C)	Device Marking (4/5)	Samples
LM5111-1M/NOPB	LIFEBUY	SOIC	D	8	95	RoHS & Green	SN	Level-1-260C-UNLIM	-40 to 125	5111 -1M	
LM5111-1MX/NOPB	ACTIVE	SOIC	D	8	2500	RoHS & Green	SN	Level-1-260C-UNLIM	-40 to 125	5111 -1M	Samples
LM5111-1MY/NOPB	ACTIVE	HVSSOP	DGN	8	1000	RoHS & Green	SN	Level-1-260C-UNLIM		SJKB	Samples
LM5111-1MYX/NOPB	ACTIVE	HVSSOP	DGN	8	3500	RoHS & Green	SN	Level-1-260C-UNLIM		SJKB	Samples
LM5111-2M/NOPB	LIFEBUY	SOIC	D	8	95	RoHS & Green	SN	Level-1-260C-UNLIM	-40 to 125	5111 -2M	
LM5111-2MX/NOPB	ACTIVE	SOIC	D	8	2500	RoHS & Green	SN	Level-1-260C-UNLIM	-40 to 125	5111 -2M	Samples
LM5111-2MY/NOPB	LIFEBUY	HVSSOP	DGN	8	1000	RoHS & Green	SN	Level-1-260C-UNLIM		SJLB	
LM5111-2MYX/NOPB	LIFEBUY	HVSSOP	DGN	8	3500	RoHS & Green	SN	Level-1-260C-UNLIM		SJLB	
LM5111-3MX/NOPB	LIFEBUY	SOIC	D	8	2500	RoHS & Green	SN	Level-1-260C-UNLIM	-40 to 125	5111 -3M	
LM5111-4M/NOPB	LIFEBUY	SOIC	D	8	95	RoHS & Green	SN	Level-1-260C-UNLIM		5111 -4M	
LM5111-4MX/NOPB	LIFEBUY	SOIC	D	8	2500	RoHS & Green	Call TI SN	Level-1-260C-UNLIM	-40 to 125	5111 -4M	
LM5111-4MY/NOPB	LIFEBUY	HVSSOP	DGN	8	1000	RoHS & Green	SN	Level-1-260C-UNLIM		SSYB	

(1) The marketing status values are defined as follows:

ACTIVE: Product device recommended for new designs.

LIFEBUY: TI has announced that the device will be discontinued, and a lifetime-buy period is in effect.

NRND: Not recommended for new designs. Device is in production to support existing customers, but TI does not recommend using this part in a new design.

PREVIEW: Device has been announced but is not in production. Samples may or may not be available.

OBSOLETE: TI has discontinued the production of the device.

(2) **RoHS:** TI defines "RoHS" to mean semiconductor products that are compliant with the current EU RoHS requirements for all 10 RoHS substances, including the requirement that RoHS substance do not exceed 0.1% by weight in homogeneous materials. Where designed to be soldered at high temperatures, "RoHS" products are suitable for use in specified lead-free processes. TI may reference these types of products as "Pb-Free".

RoHS Exempt: TI defines "RoHS Exempt" to mean products that contain lead but are compliant with EU RoHS pursuant to a specific EU RoHS exemption.

Green: TI defines "Green" to mean the content of Chlorine (Cl) and Bromine (Br) based flame retardants meet JS709B low halogen requirements of <=1000ppm threshold. Antimony trioxide based flame retardants must also meet the <=1000ppm threshold requirement.

- (3) MSL, Peak Temp. - The Moisture Sensitivity Level rating according to the JEDEC industry standard classifications, and peak solder temperature.
- (4) There may be additional marking, which relates to the logo, the lot trace code information, or the environmental category on the device.
- (5) Multiple Device Markings will be inside parentheses. Only one Device Marking contained in parentheses and separated by a "~" will appear on a device. If a line is indented then it is a continuation of the previous line and the two combined represent the entire Device Marking for that device.
- (6) Lead finish/Ball material - Orderable Devices may have multiple material finish options. Finish options are separated by a vertical ruled line. Lead finish/Ball material values may wrap to two lines if the finish value exceeds the maximum column width.

Important Information and Disclaimer:The information provided on this page represents TI's knowledge and belief as of the date that it is provided. TI bases its knowledge and belief on information provided by third parties, and makes no representation or warranty as to the accuracy of such information. Efforts are underway to better integrate information from third parties. TI has taken and continues to take reasonable steps to provide representative and accurate information but may not have conducted destructive testing or chemical analysis on incoming materials and chemicals. TI and TI suppliers consider certain information to be proprietary, and thus CAS numbers and other limited information may not be available for release.

In no event shall TI's liability arising out of such information exceed the total purchase price of the TI part(s) at issue in this document sold by TI to Customer on an annual basis.

TAPE AND REEL INFORMATION



QUADRANT ASSIGNMENTS FOR PIN 1 ORIENTATION IN TAPE



*All dimensions are nominal

Device	Package Type	Package Drawing	Pins	SPQ	Reel Diameter (mm)	Reel Width W1 (mm)	A0 (mm)	B0 (mm)	K0 (mm)	P1 (mm)	W (mm)	Pin1 Quadrant
LM5111-1MX/NOPB	SOIC	D	8	2500	330.0	12.4	6.5	5.4	2.0	8.0	12.0	Q1
LM5111-1MY/NOPB	HVSSOP	DGN	8	1000	178.0	12.4	5.3	3.4	1.4	8.0	12.0	Q1
LM5111-1MYX/NOPB	HVSSOP	DGN	8	3500	330.0	12.4	5.3	3.4	1.4	8.0	12.0	Q1
LM5111-2MX/NOPB	SOIC	D	8	2500	330.0	12.4	6.5	5.4	2.0	8.0	12.0	Q1
LM5111-2MY/NOPB	HVSSOP	DGN	8	1000	178.0	12.4	5.3	3.4	1.4	8.0	12.0	Q1
LM5111-2MYX/NOPB	HVSSOP	DGN	8	3500	330.0	12.4	5.3	3.4	1.4	8.0	12.0	Q1
LM5111-3MX/NOPB	SOIC	D	8	2500	330.0	12.4	6.5	5.4	2.0	8.0	12.0	Q1
LM5111-4MX/NOPB	SOIC	D	8	2500	330.0	12.4	6.5	5.4	2.0	8.0	12.0	Q1
LM5111-4MY/NOPB	HVSSOP	DGN	8	1000	178.0	12.4	5.3	3.4	1.4	8.0	12.0	Q1

TAPE AND REEL BOX DIMENSIONS

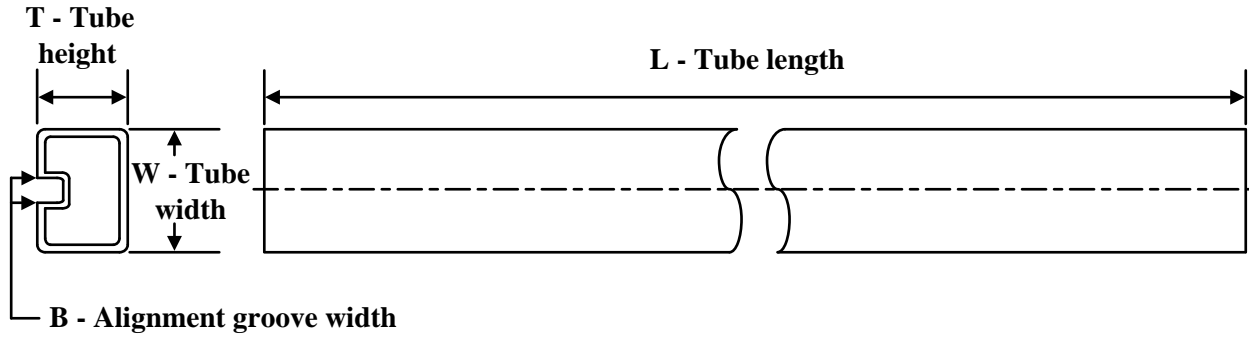

*All dimensions are nominal

Device	Package Type	Package Drawing	Pins	SPQ	Length (mm)	Width (mm)	Height (mm)
LM5111-1MX/NOPB	SOIC	D	8	2500	367.0	367.0	35.0
LM5111-1MY/NOPB	HVSSOP	DGN	8	1000	208.0	191.0	35.0
LM5111-1MYX/NOPB	HVSSOP	DGN	8	3500	367.0	367.0	35.0
LM5111-2MX/NOPB	SOIC	D	8	2500	367.0	367.0	35.0
LM5111-2MY/NOPB	HVSSOP	DGN	8	1000	208.0	191.0	35.0
LM5111-2MYX/NOPB	HVSSOP	DGN	8	3500	367.0	367.0	35.0
LM5111-3MX/NOPB	SOIC	D	8	2500	367.0	367.0	35.0
LM5111-4MX/NOPB	SOIC	D	8	2500	367.0	367.0	35.0
LM5111-4MY/NOPB	HVSSOP	DGN	8	1000	208.0	191.0	35.0

TUBE

*All dimensions are nominal

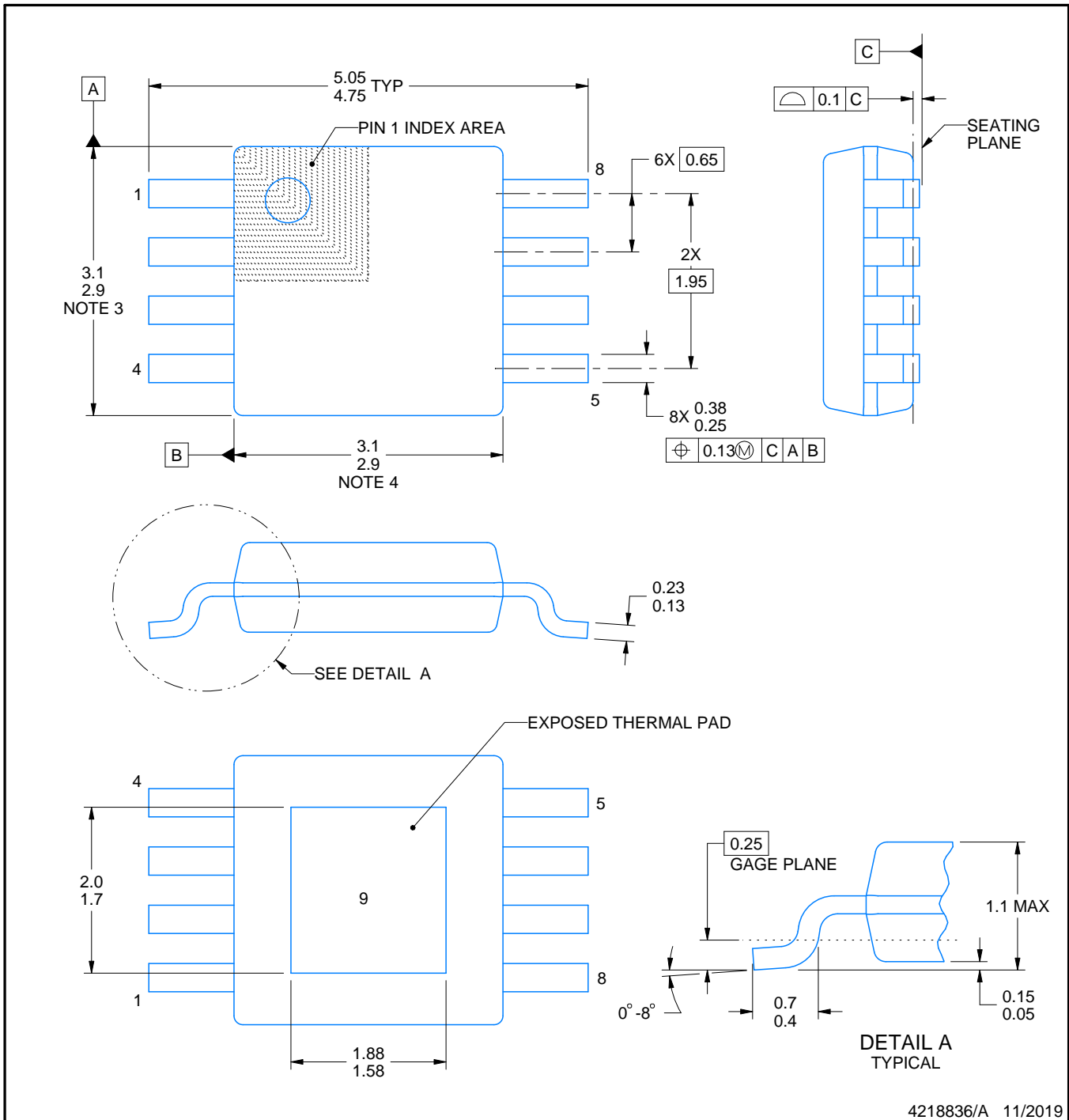
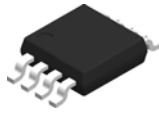
Device	Package Name	Package Type	Pins	SPQ	L (mm)	W (mm)	T (μm)	B (mm)
LM5111-1M/NOPB	D	SOIC	8	95	495	8	4064	3.05
LM5111-2M/NOPB	D	SOIC	8	95	495	8	4064	3.05
LM5111-4M/NOPB	D	SOIC	8	95	495	8	4064	3.05



4218836/A 11/2019

NOTES:

PowerPAD is a trademark of Texas Instruments.

1. All linear dimensions are in millimeters. Any dimensions in parenthesis are for reference only. Dimensioning and tolerancing per ASME Y14.5M.
2. This drawing is subject to change without notice.
3. This dimension does not include mold flash, protrusions, or gate burrs. Mold flash, protrusions, or gate burrs shall not exceed 0.15 mm per side.
4. This dimension does not include interlead flash. Interlead flash shall not exceed 0.25 mm per side.
5. Reference JEDEC registration MO-187.

EXAMPLE BOARD LAYOUT

DGN0008A

PowerPAD™ VSSOP - 1.1 mm max height

SMALL OUTLINE PACKAGE

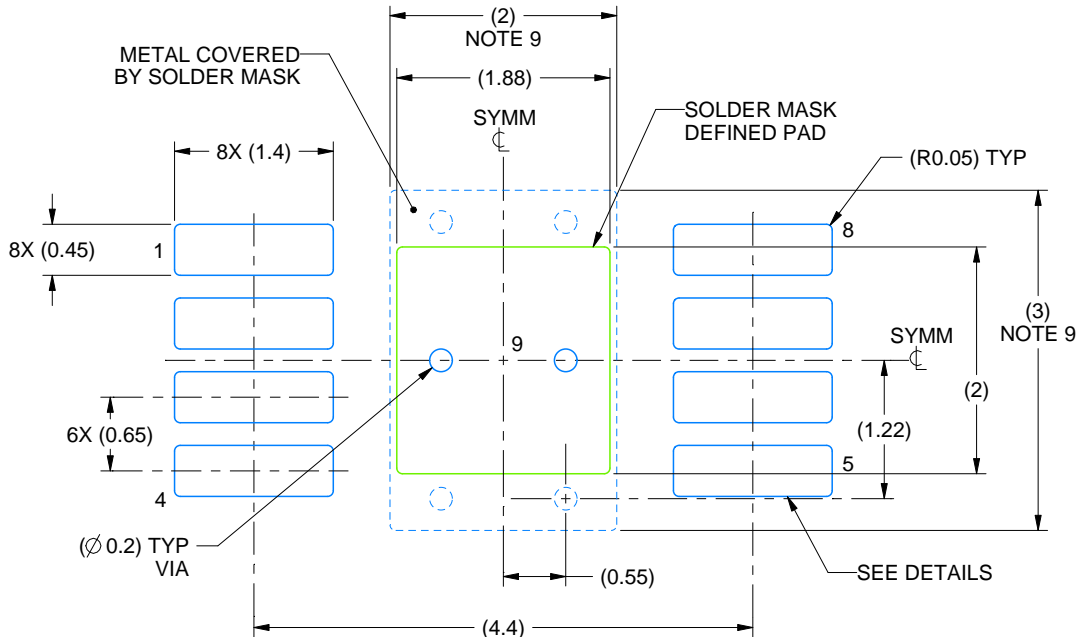

LAND PATTERN EXAMPLE
EXPOSED METAL SHOWN
SCALE: 15X

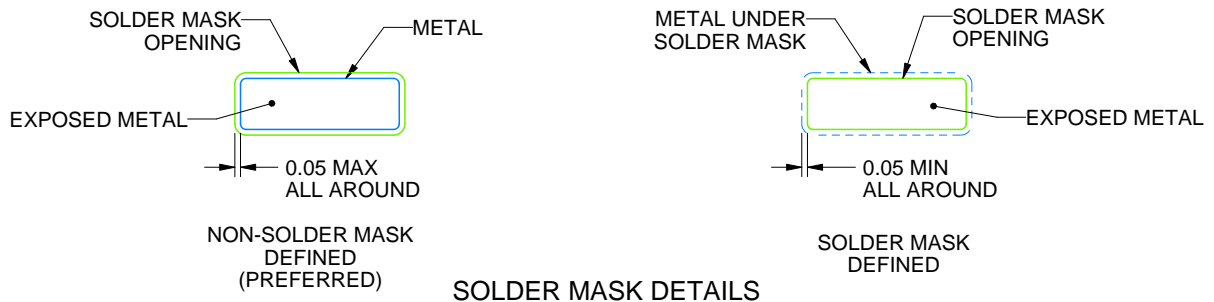

SOLDER MASK DETAILS

4218836/A 11/2019

NOTES: (continued)

6. Publication IPC-7351 may have alternate designs.
7. Solder mask tolerances between and around signal pads can vary based on board fabrication site.
8. Vias are optional depending on application, refer to device data sheet. If any vias are implemented, refer to their locations shown on this view. It is recommended that vias under paste be filled, plugged or tented.
9. Size of metal pad may vary due to creepage requirement.

EXAMPLE STENCIL DESIGN

DGN0008A

PowerPAD™ VSSOP - 1.1 mm max height

SMALL OUTLINE PACKAGE

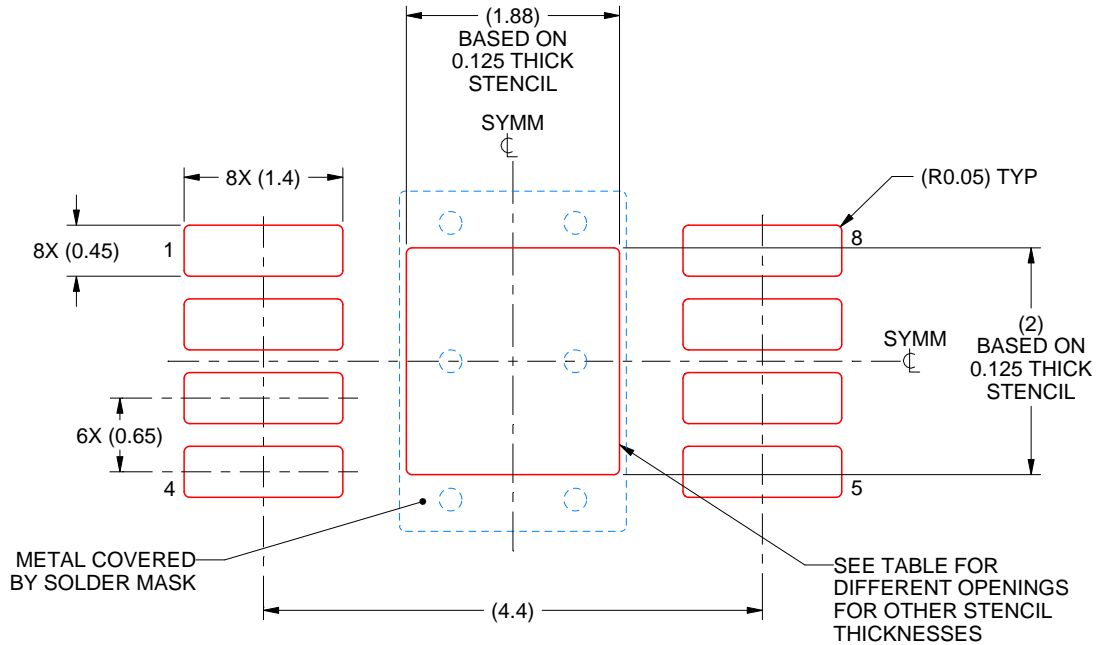

SOLDER PASTE EXAMPLE
EXPOSED PAD 9:
100% PRINTED SOLDER COVERAGE BY AREA
SCALE: 15X

STENCIL THICKNESS	SOLDER STENCIL OPENING
0.1	2.10 X 2.24
0.125	1.88 X 2.00 (SHOWN)
0.15	1.72 X 1.83
0.175	1.59 X 1.69

4218836/A 11/2019

NOTES: (continued)

10. Laser cutting apertures with trapezoidal walls and rounded corners may offer better paste release. IPC-7525 may have alternate design recommendations.
11. Board assembly site may have different recommendations for stencil design.



D0008A

PACKAGE OUTLINE

SOIC - 1.75 mm max height

SMALL OUTLINE INTEGRATED CIRCUIT



4214825/C 02/2019

NOTES:

1. Linear dimensions are in inches [millimeters]. Dimensions in parenthesis are for reference only. Controlling dimensions are in inches. Dimensioning and tolerancing per ASME Y14.5M.
2. This drawing is subject to change without notice.
3. This dimension does not include mold flash, protrusions, or gate burrs. Mold flash, protrusions, or gate burrs shall not exceed $.006$ [0.15] per side.
4. This dimension does not include interlead flash.
5. Reference JEDEC registration MS-012, variation AA.

EXAMPLE BOARD LAYOUT

D0008A

SOIC - 1.75 mm max height

SMALL OUTLINE INTEGRATED CIRCUIT



LAND PATTERN EXAMPLE
EXPOSED METAL SHOWN
SCALE:8X



SOLDER MASK DETAILS

4214825/C 02/2019

NOTES: (continued)

- 6. Publication IPC-7351 may have alternate designs.
- 7. Solder mask tolerances between and around signal pads can vary based on board fabrication site.

EXAMPLE STENCIL DESIGN

D0008A

SOIC - 1.75 mm max height

SMALL OUTLINE INTEGRATED CIRCUIT



SOLDER PASTE EXAMPLE
BASED ON .005 INCH [0.125 MM] THICK STENCIL
SCALE:8X

4214825/C 02/2019

NOTES: (continued)

8. Laser cutting apertures with trapezoidal walls and rounded corners may offer better paste release. IPC-7525 may have alternate design recommendations.
9. Board assembly site may have different recommendations for stencil design.

IMPORTANT NOTICE AND DISCLAIMER

TI PROVIDES TECHNICAL AND RELIABILITY DATA (INCLUDING DATA SHEETS), DESIGN RESOURCES (INCLUDING REFERENCE DESIGNS), APPLICATION OR OTHER DESIGN ADVICE, WEB TOOLS, SAFETY INFORMATION, AND OTHER RESOURCES "AS IS" AND WITH ALL FAULTS, AND DISCLAIMS ALL WARRANTIES, EXPRESS AND IMPLIED, INCLUDING WITHOUT LIMITATION ANY IMPLIED WARRANTIES OF MERCHANTABILITY, FITNESS FOR A PARTICULAR PURPOSE OR NON-INFRINGEMENT OF THIRD PARTY INTELLECTUAL PROPERTY RIGHTS.

These resources are intended for skilled developers designing with TI products. You are solely responsible for (1) selecting the appropriate TI products for your application, (2) designing, validating and testing your application, and (3) ensuring your application meets applicable standards, and any other safety, security, regulatory or other requirements.

These resources are subject to change without notice. TI grants you permission to use these resources only for development of an application that uses the TI products described in the resource. Other reproduction and display of these resources is prohibited. No license is granted to any other TI intellectual property right or to any third party intellectual property right. TI disclaims responsibility for, and you will fully indemnify TI and its representatives against, any claims, damages, costs, losses, and liabilities arising out of your use of these resources.

TI's products are provided subject to [TI's Terms of Sale](#) or other applicable terms available either on [ti.com](https://www.ti.com) or provided in conjunction with such TI products. TI's provision of these resources does not expand or otherwise alter TI's applicable warranties or warranty disclaimers for TI products.

TI objects to and rejects any additional or different terms you may have proposed.

Mailing Address: Texas Instruments, Post Office Box 655303, Dallas, Texas 75265
Copyright © 2023, Texas Instruments Incorporated

Looking for pricing, stock, or lifecycle information?

Click below to explore more details on WIN SOURCE:

 [View LM5111-2MY/NOPB on WIN SOURCE](#)

 [Texas Instruments](#) Information

Optimize Your Supply Chain with WIN SOURCE Solutions

-  Global Sourcing Solution
-  Obsolete Management
-  Cost Control Management
-  Shortage Management
-  Alternative Solution
-  Excess Inventory Management