

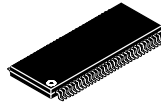

THE DATASHEET OF SN65MLVD080DGGR





8-CHANNEL HALF-DUPLEX M-LVDS LINE TRANSCEIVERS

FEATURES

- **Low-Voltage Differential 30-Ω to 55-Ω Line Drivers and Receivers for Signaling Rates ⁽¹⁾ Up to 250 Mbps; Clock Frequencies Up to 125 MHz**
- **Meets or Exceeds the M-LVDS Standard TIA/EIA-899 for Multipoint Data Interchange**
- **Controlled Driver Output Voltage Transition Times for Improved Signal Quality**
- **–1 V to 3.4 V Common-Mode Voltage Range Allows Data Transfer With 2 V of Ground Noise**
- **Bus Pins High Impedance When Driver Disabled or $V_{CC} \leq 1.5$ V**
- **Independent Enables for each Driver**
- **Bus Pin ESD Protection Exceeds 8 kV**
- **Packaged in 64-Pin TSSOP (DGG)**
- **M-LVDS Bus Power Up/Down Glitch Free**

APPLICATIONS

- **Parallel Multipoint Data and Clock Transmission Via Backplanes and Cables**
- **Low-Power High-Speed Short-Reach Alternative to TIA/EIA-485**
- **Cellular Base Stations**
- **Central-Office Switches**
- **Network Switches and Routers**

DESCRIPTION

The SN65MLVD080 and SN65MLVD082 provide eight half-duplex transceivers for transmitting and receiving Multipoint-Low-Voltage Differential Signals in full compliance with the TIA/EIA-899 (M-LVDS) standard, which are optimized to operate at signaling rates up to 250 Mbps. The driver outputs have been designed to support multipoint buses presenting loads as low as 30-Ω and incorporates controlled transition times to allow for stubs off of the backbone transmission line.

- (1) The signaling rate of a line, is the number of voltage transitions that are made per second expressed in the units bps (bits per second).

The M-LVDS standard defines two types of receivers, designated as Type-1 and Type-2. Type-1 receivers (SN65MLVD080) have thresholds centered about zero with 25 mV of hysteresis to prevent output oscillations with loss of input; Type-2 receivers (SN65MLVD082) implement a failsafe by using an offset threshold. In addition, the driver rise and fall times are between 1 and 2.0 ns, complying with the M-LVDS standard to provide operation at 250 Mbps while also accommodating stubs on the bus. Receiver outputs are slew rate controlled to reduce EMI and crosstalk effects associated with large current surges. The M-LVDS standard allows for 32 nodes on the bus providing a high-speed replacement for RS-485 where lower common-mode can be tolerated or when higher signaling rates are needed.

The driver logic inputs and the receiver logic outputs are on separate pins rather than tied together as in some transceiver designs. The drivers have separate enables (DE) and the receivers are enabled globally through (\overline{RE}). This arrangement of separate logic inputs, logic outputs, and enable pins allows for a listen-while-talking operation. The devices are characterized for operation from –40°C to 85°C.

LOGIC DIAGRAM (POSITIVE LOGIC)

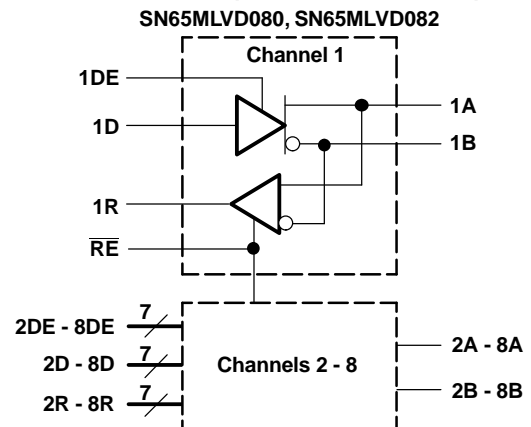

Please be aware that an important notice concerning availability, standard warranty, and use in critical applications of Texas Instruments semiconductor products and disclaimers thereto appears at the end of this data sheet.



These devices have limited built-in ESD protection. The leads should be shorted together or the device placed in conductive foam during storage or handling to prevent electrostatic damage to the MOS gates.

ORDERING INFORMATION

PART NUMBER	RECEIVER TYPE	PACKAGE MARKING	PACKAGE/CARRIER
SN65MLVD080DGG	Type 1	MLVD080	64-Pin TSSOP/Tube
SM65MLVD080DGGR	Type 1	MLVD080	64-Pin TSSOP/Tape and Reeled
SN65MLVD082DGG	Type 2	MLVD082	64-Pin TSSOP/Tube
SM65MLVD082DGGR	Type 2	MLVD082	64-Pin TSSOP/Tape and Reeled

PACKAGE DISSIPATION RATINGS

PACKAGE	PCB JEDEC STANDARD	$T_A \leq 25^\circ\text{C}$ POWER RATING	DERATING FACTOR ⁽¹⁾ ABOVE $T_A = 25^\circ\text{C}$	$T_A = 85^\circ\text{C}$ POWER RATING
DGG	Low-K ⁽²⁾	1204.7 mW	10.5 mW/°C	576 mW
DGG	High-K ⁽³⁾	1839.4 mW	16.0 mW/°C	880 mW

(1) This is the inverse of the junction-to-ambient thermal resistance when board mounted and with no air flow.

(2) In accordance with the Low-K thermal metric definitions of EIA/JESD51-3.

(3) In accordance with the High-K thermal metric definitions of EIA/JESD51-7.

THERMAL CHARACTERISTICS

PARAMETER	TEST CONDITIONS	MIN	TYP	MAX	UNIT
θ_{JB} Junction-to-board thermal resistance			41.08		°C/W
θ_{JC} Junction-to-case thermal resistance			6.78		°C/W
Device power dissipation	$V_{CC} = 3.3\text{ V}$, $DE = V_{CC}$, $\overline{RE} = \text{GND}$, $C_L = 15\text{ pF}$, $R_L = 50\ \Omega$, 250 Mbps random data on each input		477		mW
	$V_{CC} = 3.6\text{ V}$, $DE = V_{CC}$, $\overline{RE} = \text{GND}$, $C_L = 15\text{ pF}$, $R_L = 50\ \Omega$, 250 Mbps data on one input and 125 MHz clock on the others			854 ⁽¹⁾	

(1) When all channels are running at a 125-MHz clock frequency, a 250 lfm is required for a low-K board, and 150 lfm is required for a high-K board. In such applications, a TI 1:8 or dual 1:4 M-LVDS buffer is highly recommended, SN65MLVD128 or SN65MLVD129, to fan out clock signals in multiple paths.

ABSOLUTE MAXIMUM RATINGS

over operating free-air temperature range unless otherwise noted⁽¹⁾

		SN65MLVD080, 082	
Supply voltage range ⁽²⁾ , V_{CC}		-0.5 V to 4 V	
Input voltage range	D, DE, \overline{RE}	-0.5 V to 4 V	
	A, B	-1.8 V to 4 V	
Output voltage range	R	-0.3 V to 4 V	
	A, or B	-1.8 V to 4 V	
Electrostatic discharge	Human Body Model ⁽³⁾	A, B	±8 kV
		All pins	±2 kV
	Charged-Device Model ⁽⁴⁾	All pins	±1500 V
Continuous power dissipation		See Dissipation Rating Table	
Storage temperature range		-65°C to 150°C	

(1) Stresses beyond those listed under *absolute maximum ratings* may cause permanent damage to the device. These are stress ratings only, and functional operation of the device at these or any other conditions beyond those indicated under *recommended operating conditions* is not implied. Exposure to absolute-maximum-rated conditions for extended periods may affect device reliability.

(2) All voltage values, except differential I/O bus voltages, are with respect to network ground terminal.

(3) Tested in accordance with JEDEC Standard 22, Test Method A114-A.

(4) Tested in accordance with JEDEC Standard 22, Test Method C101.

RECOMMENDED OPERATING CONDITIONS

	MIN	NOM	MAX	UNIT
V_{CC} Supply voltage	3	3.3	3.6	V
V_{IH} High-level input voltage	2		V_{CC}	V
V_{IL} Low-level input voltage	GND		0.8	V
Voltage at any bus terminal V_A or V_B	-1.4		3.8	V
$ V_{ID} $ Magnitude of differential input voltage	0.05		V_{CC}	V
T_A Operating free-air temperature	-40		85	°C
Maximum junction temperature			140	°C

DEVICE ELECTRICAL CHARACTERISTICS

over recommended operating conditions unless otherwise noted

PARAMETER		TEST CONDITIONS	MIN	TYP ⁽¹⁾	MAX	UNIT
I_{CC} Supply current	Driver only	\overline{RE} and DE at V_{CC} , $R_L = 50 \Omega$, All others open		110	140	mA
	Both disabled	\overline{RE} at V_{CC} , DE at 0 V, $R_L =$ No Load, All others open		5	8	
	Both enabled	\overline{RE} at 0 V, DE at V_{CC} , $R_L = 50 \Omega$, $C_L = 15$ pF, All others open		140	180	
	Receiver only	\overline{RE} at 0 V, DE at 0 V, $C_L = 15$ pF, All others open		38	50	

(1) All typical values are at 25°C and with a 3.3-V supply voltage.

DRIVER ELECTRICAL CHARACTERISTICS

over recommended operating conditions unless otherwise noted

PARAMETER		TEST CONDITIONS	MIN ⁽¹⁾	TYP ⁽²⁾	MAX	UNIT
$ V_{AB} $	Differential output voltage magnitude (A, B)	See Figure 2	480		650	mV
$\Delta V_{AB} $	Change in differential output voltage magnitude between logic states (A, B)		-50		50	mV
$V_{OS(SS)}$	Steady-state common-mode output voltage (A, B)	See Figure 3	0.8		1.2	V
$\Delta V_{OS(SS)}$	Change in steady-state common-mode output voltage between logic states (A, B)		-50		50	mV
$V_{OS(PP)}$	Peak-to-peak common-mode output voltage (A, B)				150	mV
$V_{A(OC)}$	Maximum steady-state open-circuit output voltage (A, B)	See Figure 7	0		2.4	V
$V_{B(OC)}$	Maximum steady-state open-circuit output voltage (A, B)		0		2.4	V
$V_{P(H)}$	Voltage overshoot, low-to-high level output (A, B)	See Figure 5			1.2 V_{SS}	V
$V_{P(L)}$	Voltage overshoot, high-to-low level output (A, B)		-0.2 V_{SS}			V
I_{IH}	High-level input current (D, DE)	$V_{IH} = 2$ V to V_{CC}			10	μ A
I_{IL}	Low-level input current (D, DE)	$V_{IL} =$ GND to 0.8 V			10	μ A
$ I_{OS} $	Differential short-circuit output current magnitude (A, B)	See Figure 4			24	mA
C_i	Input capacitance (D, DE)	$V_i = 0.4 \sin(30E6\pi t) + 0.5$ V ⁽³⁾		5		pF

(1) The algebraic convention, in which the least positive (most negative) limit is designated as minimum is used in this data sheet.

(2) All typical values are at 25°C and with a 3.3-V supply voltage.

(3) HP4194A impedance analyzer (or equivalent)

RECEIVER ELECTRICAL CHARACTERISTICS

over recommended operating conditions unless otherwise noted

PARAMETER		TEST CONDITIONS	MIN	TYP ⁽¹⁾	MAX	UNIT
V _{IT+}	Positive-going differential input voltage threshold (A, B)	Type 1			50	mV
		Type 2			150	
V _{IT-}	Negative-going differential input voltage threshold (A, B)	Type 1	See Figure 9, Table 1 and Table 2	-50		mV
		Type 2		50		
V _{HYS}	Differential input voltage hysteresis, (V _{IT+} – V _{IT-}) (A, B)	Type 1		25		mV
		Type 2		0		
V _{OH}	High-level output voltage (R)	I _{OH} = –8 mA	2.4			V
V _{OL}	Low-level output voltage (R)	I _{OL} = 8 mA			0.4	V
I _{IH}	High-level input current (\overline{RE})	V _{IH} = 2 V to V _{CC}	-10			μA
I _{IL}	Low-level input current (\overline{RE})	V _{IL} = GND to 0.8 V	-10			μA
I _{OZ}	High-impedance output current (R)	V _O = 0 V or V _{CC}	-10		15	μA

(1) All typical values are at 25°C and with a 3.3-V supply voltage.

BUS INPUT AND OUTPUT ELECTRICAL CHARACTERISTICS

over recommended operating conditions unless otherwise noted

PARAMETER		TEST CONDITIONS	MIN	TYP ⁽¹⁾	MAX	UNIT
I _A	Receiver or transceiver with driver disabled input current	V _A = 3.8 V, V _B = 1.2 V	0		32	μA
		V _A = 0 V or 2.4 V, V _B = 1.2 V	-20		20	
		V _A = –1.4 V, V _B = 1.2 V	-32		0	
I _B	Receiver or transceiver with driver disabled input current	V _B = 3.8 V, V _A = 1.2 V	0		32	μA
		V _B = 0 V or 2.4 V, V _A = 1.2 V	-20		20	
		V _B = –1.4 V, V _A = 1.2 V	-32		0	
I _{AB}	Receiver or transceiver with driver disabled differential input current (I _A – I _B)	V _A = V _B , 1.4 ≤ V _A ≤ 3.8 V	-4		4	μA
I _{A(OFF)}	Receiver or transceiver power-off input current	V _A = 3.8 V, V _B = 1.2 V, 0 V ≤ V _{CC} ≤ 1.5 V	0		32	μA
		V _A = 0 V or 2.4 V, V _B = 1.2 V, 0 V ≤ V _{CC} ≤ 1.5 V	-20		20	
		V _A = –1.4 V, V _B = 1.2 V, 0 V ≤ V _{CC} ≤ 1.5 V	-32		0	
I _{B(OFF)}	Receiver or transceiver power-off input current	V _B = 3.8 V, V _A = 1.2 V, 0 V ≤ V _{CC} ≤ 1.5 V	0		32	μA
		V _B = 0 V or 2.4 V, V _A = 1.2 V, 0 V ≤ V _{CC} ≤ 1.5 V	-20		20	
		V _B = –1.4 V, V _A = 1.2 V, 0 V ≤ V _{CC} ≤ 1.5 V	-32		0	
I _{AB(OFF)}	Receiver input or transceiver power-off differential input current (I _{A(off)} – I _{B(off)})	V _A = V _B , 0 V ≤ V _{CC} ≤ 1.5 V, –1.4 ≤ V _A ≤ 3.8 V	-4		4	μA
C _A	Transceiver with driver disabled input capacitance	V _A = 0.4 sin (30E6πt) + 0.5 V ⁽²⁾ , V _B = 1.2 V			5	pF
C _B	Transceiver with driver disabled input capacitance	V _B = 0.4 sin (30E6πt) + 0.5 V ⁽²⁾ , V _A = 1.2 V			5	pF
C _{AB}	Transceiver with driver disabled differential input capacitance	V _{AB} = 0.4 sin (30E6πt)V ⁽²⁾			3	pF
C _{A/B}	Transceiver with driver disabled input capacitance balance, (C _A /C _B)		0.99		1.01	

(1) All typical values are at 25°C and with a 3.3-V supply voltage.

(2) HP4194A impedance analyzer (or equivalent)

DRIVER SWITCHING CHARACTERISTICS

over recommended operating conditions unless otherwise noted

PARAMETER		TEST CONDITIONS	MIN	TYP ⁽¹⁾	MAX	UNIT
t_{pLH}	Propagation delay time, low-to-high-level output	See Figure 5	1	1.5	2.4	ns
t_{pHL}	Propagation delay time, high-to-low-level output		1	1.5	2.4	ns
t_r	Differential output signal rise time		1		2	ns
t_f	Differential output signal fall time		1		2	ns
$t_{sk(o)}$	Output skew				350	ps
$t_{sk(p)}$	Pulse skew ($ t_{pHL} - t_{pLH} $)			0	150	ps
$t_{sk(pp)}$	Part-to-part skew ⁽²⁾				600	ps
$t_{jit(per)}$	Period jitter, rms (1 standard deviation) ⁽³⁾		100 MHz clock input ⁽⁴⁾		4	ps
$t_{jit(c-c)}$	Cycle-to-cycle jitter, rms				45	ps
$t_{jit(det)}$	Deterministic jitter		200 Mbps 2 ¹⁵ -1 PRBS input ⁽⁵⁾			150
$t_{jit(pp)}$	Peak-to-peak jitter ⁽²⁾⁽⁶⁾				190	ps
t_{PZH}	Enable time, high-impedance-to-high-level output	See Figure 6				7
t_{PZL}	Enable time, high-impedance-to-low-level output				7	ns
t_{PHZ}	Disable time, high-level-to-high-impedance output				7	ns
t_{PLZ}	Disable time, low-level-to-high-impedance output				7	ns

(1) All typical values are at 25°C and with a 3.3-V supply voltage.

(2) $t_{sk(pp)}$ is the magnitude of the time difference in propagation delay times between any specified terminals of two devices when both devices operate with the same supply voltages, at the same temperature, and have identical packages and test circuits.

(3) Jitter is ensured by design and characterization. Stimulus jitter has been subtracted from the numbers.

(4) $t_r = t_f = 0.5$ ns (10% to 90%), measured over 30 k samples.

(5) $t_r = t_f = 0.5$ ns (10% to 90%), measured over 100 k samples.

(6) Peak-to-peak jitter includes jitter due to pulse skew ($t_{sk(p)}$).

RECEIVER SWITCHING CHARACTERISTICS

over recommended operating conditions unless otherwise noted

PARAMETER		TEST CONDITIONS	MIN	TYP ⁽¹⁾	MAX	UNIT
t_{pLH}	Propagation delay time, low-to-high-level output	$C_L = 15$ pF, See Figure 10	2	4	6	ns
t_{pHL}	Propagation delay time, high-to-low-level output		2	4	6	ns
t_r	Output signal rise time		1		2.3	ns
t_f	Output signal fall time		1		2.3	ns
$t_{sk(o)}$	Output skew				350	ps
$t_{sk(p)}$	Pulse skew ($ t_{pHL} - t_{pLH} $)			50	350	ps
$t_{sk(pp)}$	Part-to-part skew ⁽²⁾				1	ns
$t_{jit(per)}$	Period jitter, rms (1 standard deviation) ⁽³⁾	100 MHz clock input ⁽⁴⁾			7	ps
$t_{jit(c-c)}$	Cycle-to-cycle jitter, rms				110	ps
$t_{jit(det)}$	Deterministic jitter	Type 1			550	ps
		Type 2			480	ps
$t_{jit(pp)}$	Peak-to-peak jitter ⁽³⁾⁽⁶⁾	Type 1			720	ps
		Type 2			660	ps
t_{pZH}	Enable time, high-impedance-to-high-level output	$C_L = 15$ pF, See Figure 11			30	ns
t_{pZL}	Enable time, high-impedance-to-low-level output				30	ns
t_{pHZ}	Disable time, high-level-to-high-impedance output				18	ns
t_{pLZ}	Disable time, low-level-to-high-impedance output				28	ns

(1) All typical values are at 25°C and with a 3.3-V supply voltage.

(2) $t_{sk(pp)}$ is the magnitude of the time difference in propagation delay times between any specified terminals of two devices when both devices operate with the same supply voltages, at the same temperature, and have identical packages and test circuits.

(3) Jitter is ensured by design and characterization. Stimulus jitter has been subtracted from the numbers.

(4) $V_{ID} = 200$ mV_{pp} ('080), $V_{ID} = 400$ mV_{pp} ('082), $V_{cm} = 1$ V, $t_r = t_f = 0.5$ ns (10% to 90%), measured over 30 k samples.

(5) $V_{ID} = 200$ mV_{pp} ('080), $V_{ID} = 400$ mV_{pp} ('082), $V_{cm} = 1$ V, $t_r = t_f = 0.5$ ns (10% to 90%), measured over 100 k samples.

(6) Peak-to-peak jitter includes jitter due to pulse skew ($t_{sk(p)}$).

PARAMETER MEASUREMENT INFORMATION

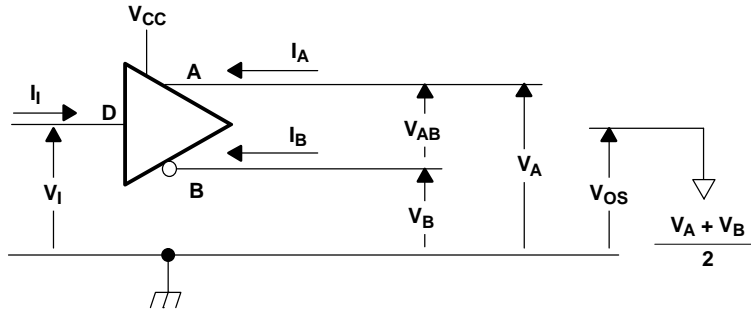
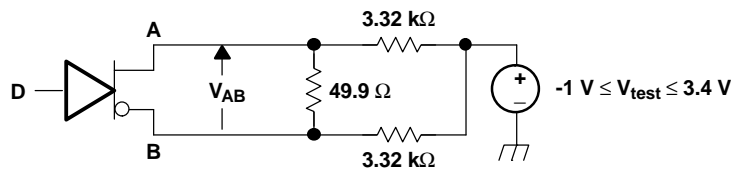
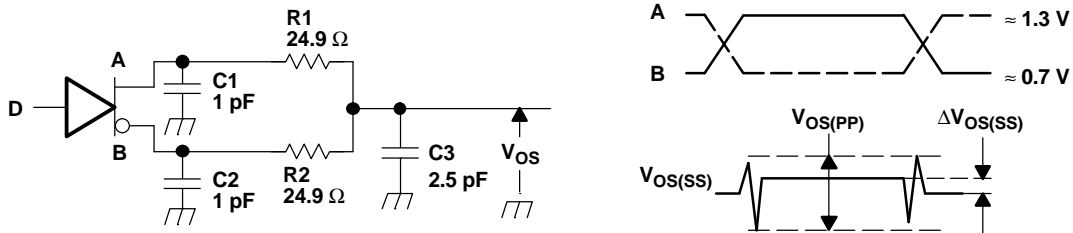

Figure 1. Driver Voltage and Current Definitions



NOTE: All resistors are 1% tolerance.

Figure 2. Differential Output Voltage Test Circuit



- A. All input pulses are supplied by a generator having the following characteristics: t_r or $t_f \leq 1$ ns, pulse frequency = 1 MHz, duty cycle = $50 \pm 5\%$.
- B. C1, C2 and C3 include instrumentation and fixture capacitance within 2 cm of the D.U.T. and are $\pm 20\%$.
- C. R1 and R2 are metal film, surface mount, $\pm 1\%$, and located within 2 cm of the D.U.T.
- D. The measurement of $V_{OS(PP)}$ is made on test equipment with a -3 dB bandwidth of at least 1 GHz.

Figure 3. Test Circuit and Definitions for the Driver Common-Mode Output Voltage

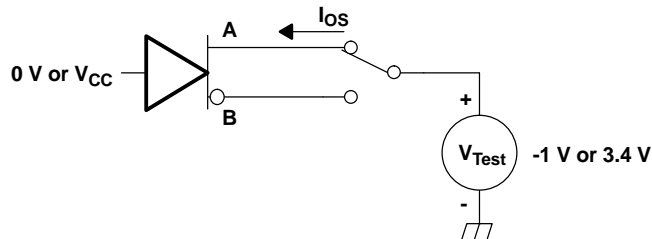
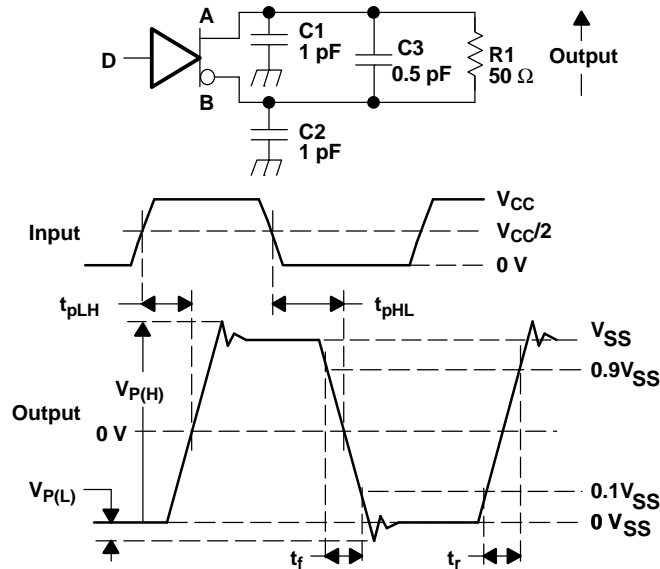

Figure 4. Driver Short-Circuit Test Circuit

PARAMETER MEASUREMENT INFORMATION (continued)



- A. All input pulses are supplied by a generator having the following characteristics: t_r or $t_f \leq 1$ ns, frequency = 1 MHz, duty cycle = $50 \pm 5\%$.
- B. C1, C2, and C3 include instrumentation and fixture capacitance within 2 cm of the D.U.T. and are $\pm 20\%$.
- C. R1 is a metal film, surface mount, and 1% tolerance and located within 2 cm of the D.U.T.
- D. The measurement is made on test equipment with a -3 dB bandwidth of at least 1 GHz.

Figure 5. Driver Test Circuit, Timing, and Voltage Definitions for the Differential Output Signal

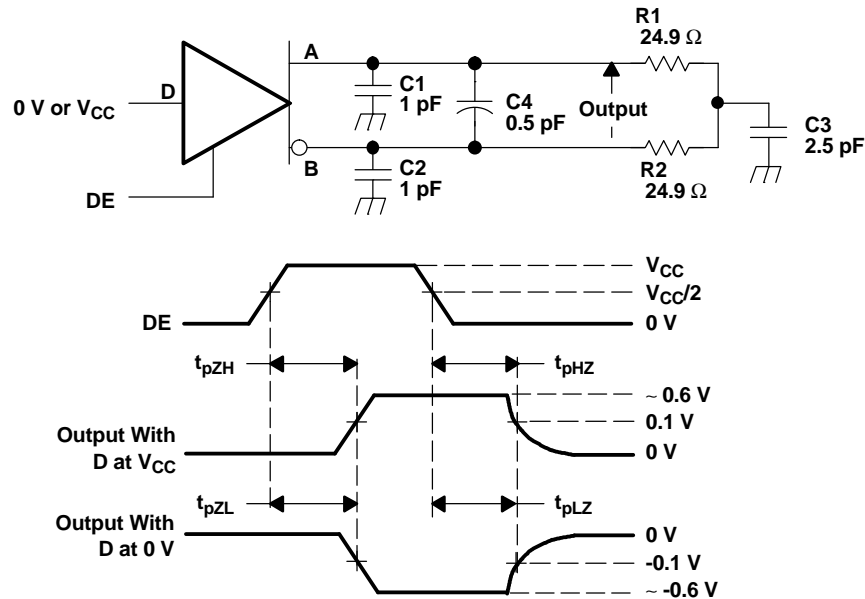

- A. All input pulses are supplied by a generator having the following characteristics: t_r or $t_f \leq 1$ ns, frequency = 1 MHz, duty cycle = $50 \pm 5\%$.
- B. C1, C2, C3, and C4 includes instrumentation and fixture capacitance within 2 cm of the D.U.T. and are $\pm 20\%$.
- C. R1 and R2 are metal film, surface mount, and 1% tolerance and located within 2 cm of the D.U.T.
- D. The measurement is made on test equipment with a -3 dB bandwidth of at least 1 GHz.

Figure 6. Driver Enable and Disable Time Circuit and Definitions

PARAMETER MEASUREMENT INFORMATION (continued)

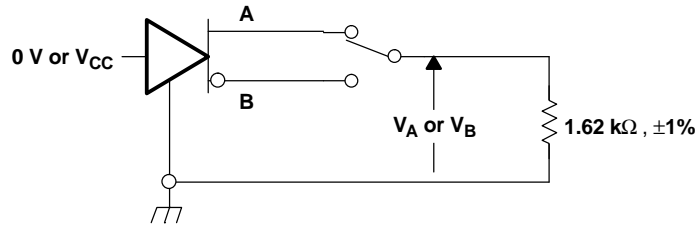
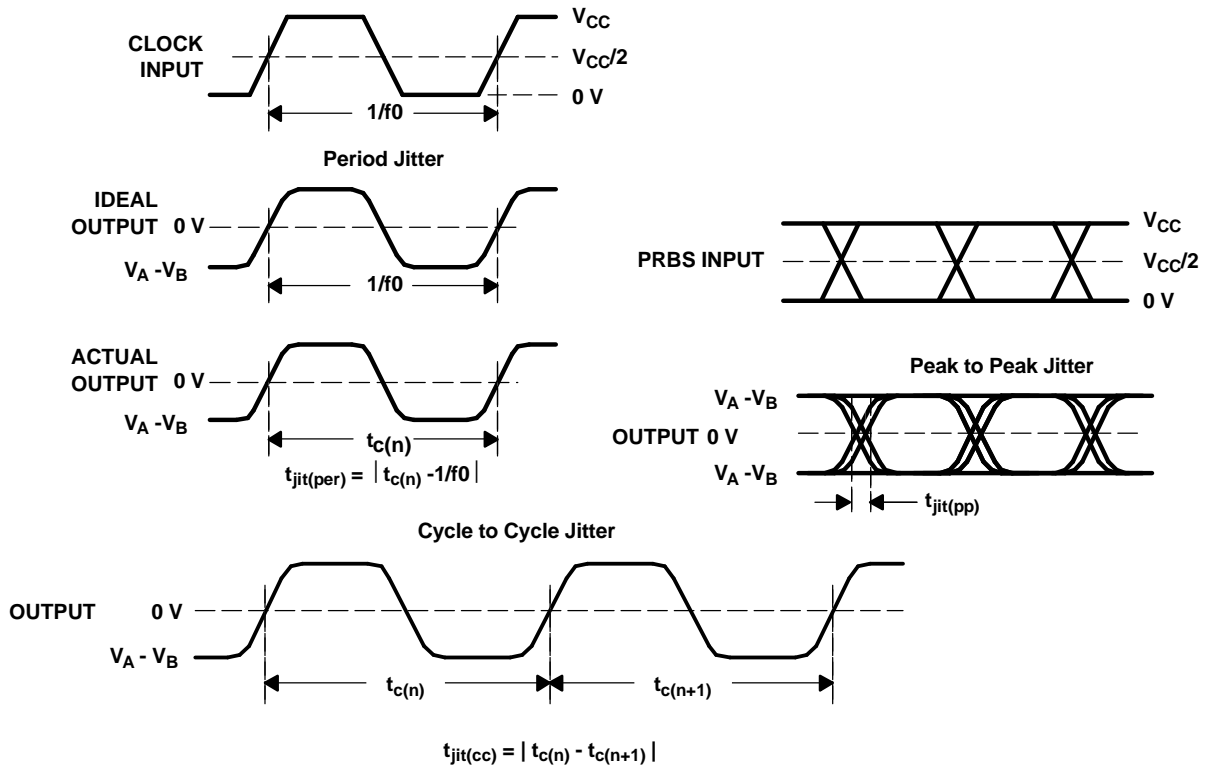

Figure 7. Maximum Steady State Output Voltage



- A. All input pulses are supplied by an Agilent 8304A Stimulus System with plug-in TBD.
- B. The measurement is made on a TEK TDS6604 running TDSJIT3 application software
- C. Period jitter and cycle-to-cycle jitter are measured using a 100 MHz 50 ±1% duty cycle clock input.
- D. Peak-to-peak jitter and deterministic jitter are measured using a 200 Mbps 2¹⁵-1 PRBS input.

Figure 8. Driver Jitter Measurement Waveforms

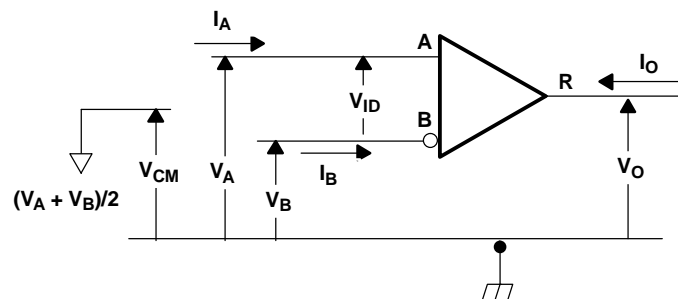

Figure 9. Receiver Voltage and Current Definitions

Table 1. Type-1 Receiver Input Threshold Test Voltages

APPLIED VOLTAGES		RESULTING DIFFERENTIAL INPUT VOLTAGE	RESULTING COMMON-MODE INPUT VOLTAGE	RECEIVER OUTPUT ⁽¹⁾
V _{IA}	V _{IB}	V _{ID}	V _{IC}	
2.400	0.000	2.400	1.200	H
0.000	2.400	-2.400	1.200	L
3.400	3.350	0.050	3.375	H
3.350	3.400	-0.050	3.375	L
-1.350	-1.400	0.050	-1.375	H
-1.400	-1.350	-0.050	-1.375	L

(1) H= high level, L = low level, output state assumes receiver is enabled ($\overline{RE} = L$)

Table 2. Type-2 Receiver Input Threshold Test Voltages

APPLIED VOLTAGES		RESULTING DIFFERENTIAL INPUT VOLTAGE	RESULTING COMMON-MODE INPUT VOLTAGE	RECEIVER OUTPUT ⁽¹⁾
V _{IA}	V _{IB}	V _{ID}	V _{IC}	
2.400	0.000	2.400	1.200	H
0.000	2.400	-2.400	1.200	L
3.400	3.250	0.150	3.325	H
3.400	3.350	0.050	3.375	L
-1.250	-1.400	0.150	-1.325	H
-1.350	-1.400	0.050	-1.375	L

(1) H= high level, L = low level, output state assumes receiver is enabled ($\overline{RE} = L$)

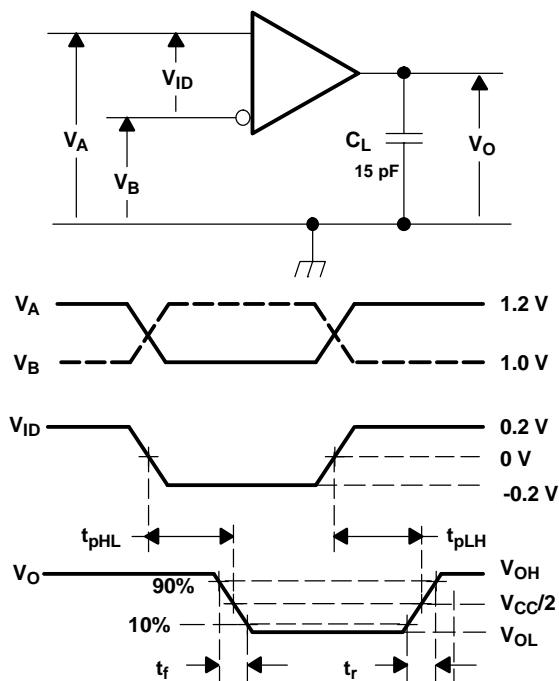

- A. All input pulses are supplied by a generator having the following characteristics: t_r or $t_f \leq 1$ ns, frequency = 1 MHz, duty cycle = $50 \pm 5\%$. C_L is a combination of a 20%-tolerance, low-loss ceramic, surface-mount capacitor and fixture capacitance within 2 cm of the D.U.T.
- B. The measurement is made on test equipment with a -3 dB bandwidth of at least 1 GHz.

Figure 10. Receiver Timing Test Circuit and Waveforms

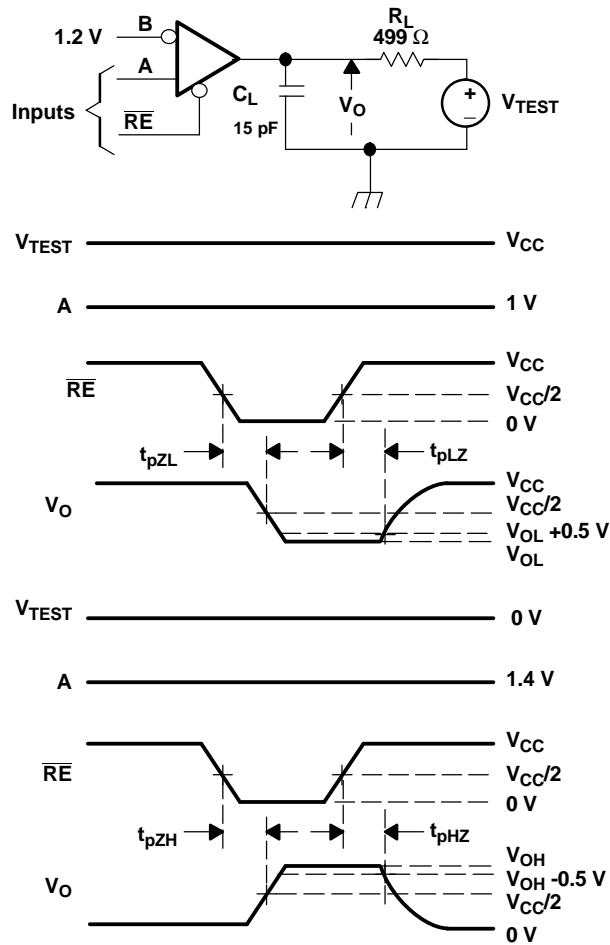

- All input pulses are supplied by a generator having the following characteristics: t_r or $t_f \leq 1$ ns, frequency = 1 MHz, duty cycle = $50 \pm 5\%$.
- R_L is 1% tolerance, metal film, surface mount, and located within 2 cm of the D.U.T.
- C_L is the instrumentation and fixture capacitance within 2 cm of the DUT and $\pm 20\%$. The measurement is made on test equipment with a -3 dB bandwidth of at least 1 GHz.

Figure 11. Receiver Enable/Disable Time Test Circuit and Waveforms

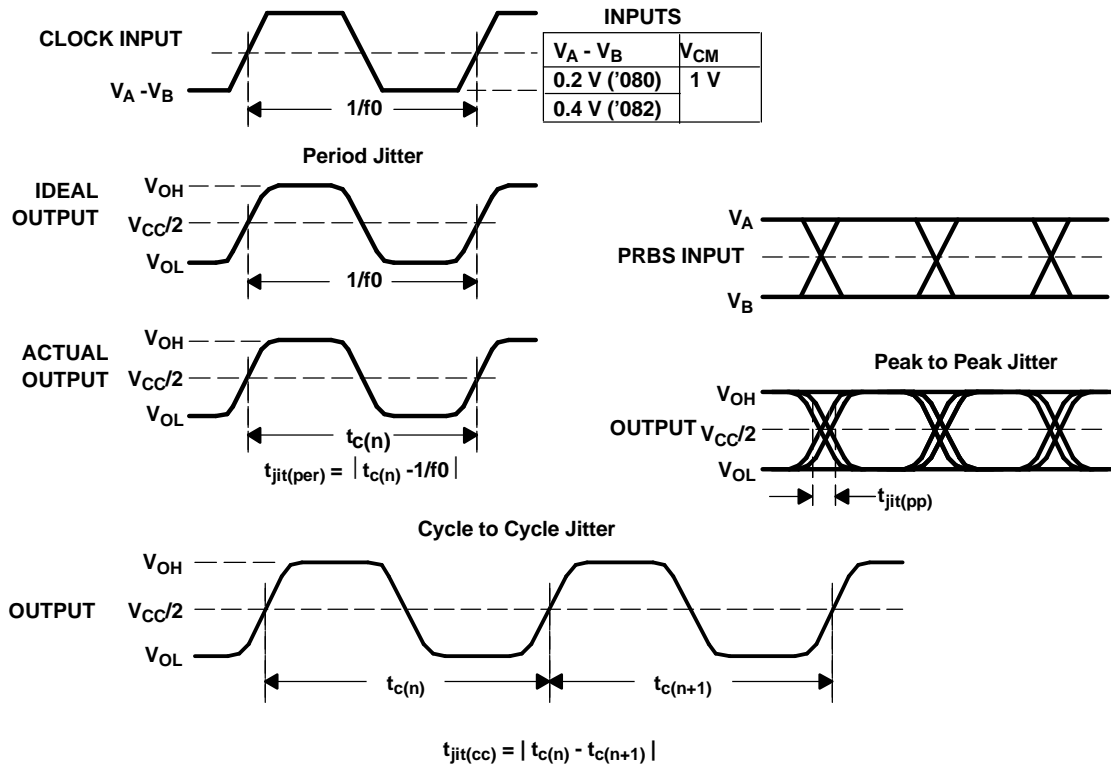

- A. All input pulses are supplied by an Agilent 8304A Stimulus System with plug-in TBD.
- B. The measurement is made on a TEK TDS6604 running TDSJIT3 application software
- C. Period jitter and cycle-to-cycle jitter are measured using a 100 MHz 50 ±1% duty cycle clock input.
- D. Peak-to-peak jitter and deterministic jitter are measured using a 200 Mbps 2¹⁵-1 PRBS input.

Figure 12. Receiver Jitter Measurement Waveforms

Table 3. Terminal Functions

NAME	PIN		TYPE	DESCRIPTION
		NO.		
1D-8D	58, 57, 52, 51, 46, 45, 40, 39		Input	Data inputs for drivers
1R-8R	59, 56, 53, 50, 47, 44, 41, 38		Output	Data output for receivers
1A-8A	6, 8, 12, 14, 18, 20, 24, 26		Bus I/O	M-LVDS bus noninverting input/output
1B-8B	7, 9, 13, 15, 19, 21, 25, 27		Bus I/O	M-LVDS bus inverting input/output
GND	10, 16, 22, 28, 36, 37, 43, 49, 55, 62, 63, 64		Power	Circuit ground
V _{CC}	5, 11, 17, 23, 34, 35, 42, 48, 54, 60, 61		Power	Supply voltage
$\overline{\text{RE}}$	33		Input	Receiver enable, active low, enables all receivers
1DE-8DE	1, 2, 3, 4, 29, 30, 31, 32		Input	Driver enable, active high, individual enables

PIN ASSIGNMENTS

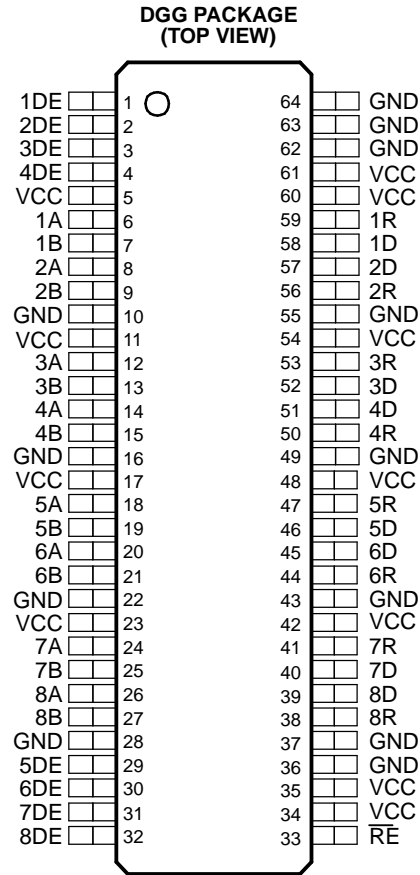

DEVICE FUNCTION TABLE

RECEIVER (080)

INPUTS		OUTPUT
$V_{ID} = V_A - V_B$	RE	R
$V_{ID} \geq 50 \text{ mV}$	L	H
$-50 \text{ mV} < V_{ID} < 50 \text{ mV}$	L	?
$V_{ID} \leq -50 \text{ mV}$	L	L
X	H	Z
X	Open	Z
Open Circuit	L	?

RECEIVER (082)

INPUTS		OUTPUT
$V_{ID} = V_A - V_B$	RE	R
$V_{ID} \geq 150 \text{ mV}$	L	H
$50 \text{ mV} < V_{ID} < 150 \text{ mV}$	L	?
$V_{ID} \leq 50 \text{ mV}$	L	L
X	H	Z
X	Open	Z
Open Circuit	L	L

DRIVERS

INPUT	ENABLE	OUTPUTS	
		A OR Y	B OR Z
L	H	L	H
H	H	H	L
OPEN	H	L	H
X	OPEN	Z	Z
X	L	Z	Z

H = high level, L = low level, Z = high impedance, X = Don't care, ? = indeterminate

EQUIVALENT INPUT AND OUTPUT SCHEMATIC DIAGRAMS

DRIVER INPUT AND DRIVER ENABLE

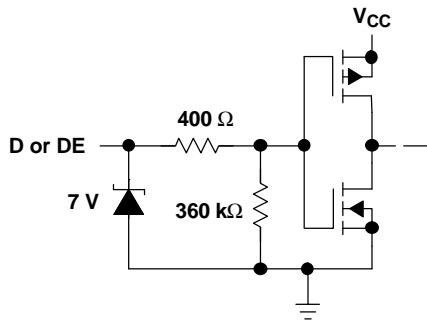

DRIVER OUTPUT

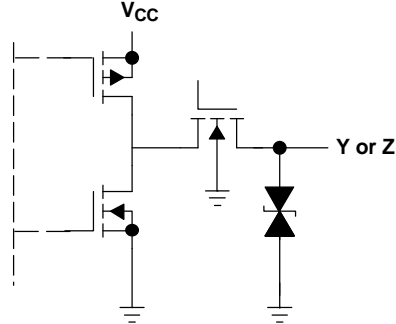

RECEIVER ENABLE

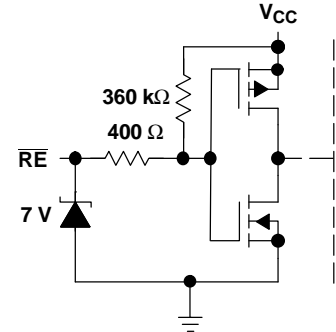

RECEIVER INPUT

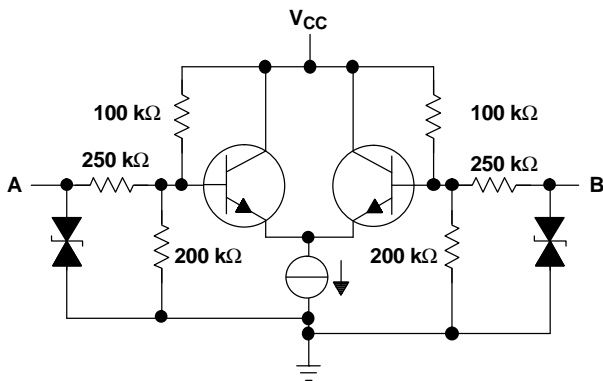

RECEIVER OUTPUT

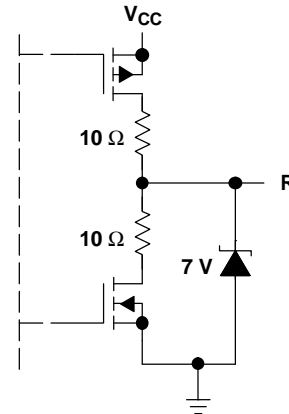

TYPICAL CHARACTERISTICS

**SUPPLY CURRENT
vs
FREQUENCY**

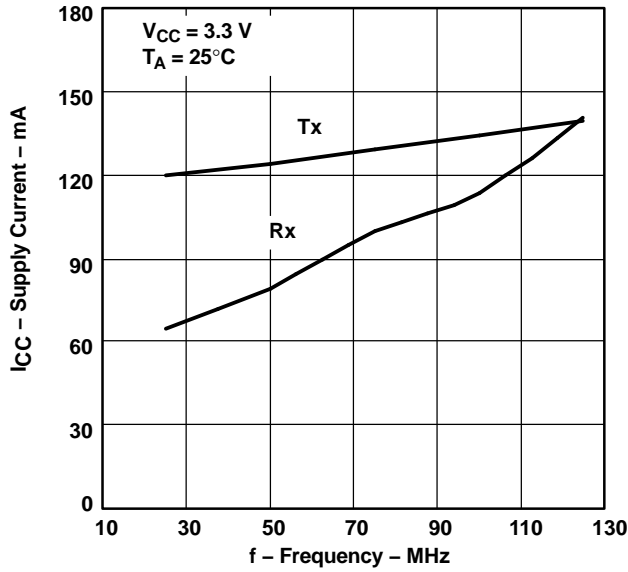

Figure 13.

**SUPPLY CURRENT
vs
FREE-AIR TEMPERATURE**

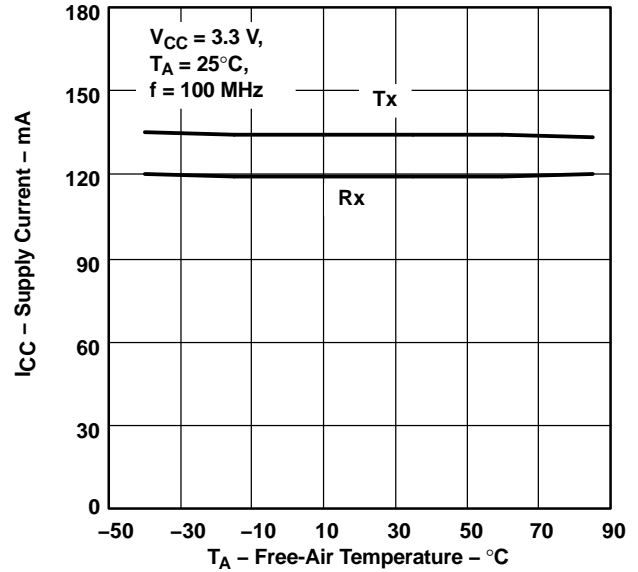

Figure 14.

**DIFFERENTIAL OUTPUT VOLTAGE
vs
FREQUENCY**

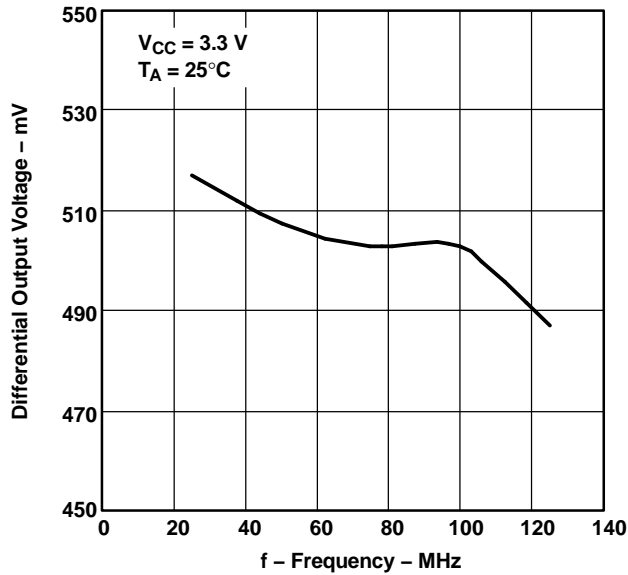

Figure 15.

**DIFFERENTIAL OUTPUT VOLTAGE
vs
OUTPUT RESISTANCE**

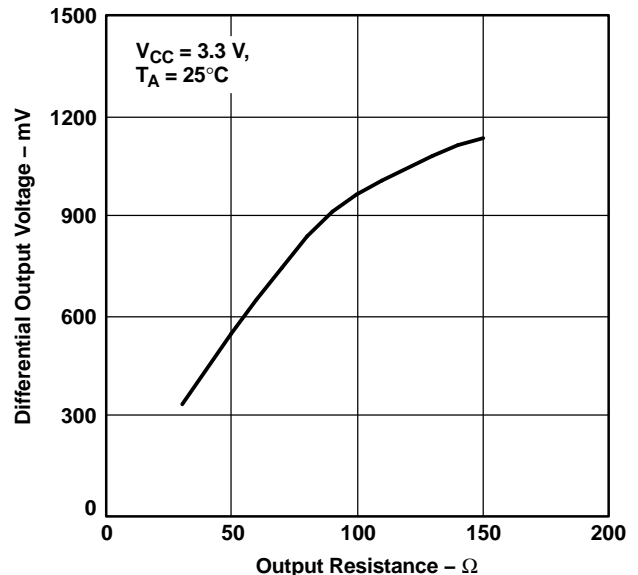
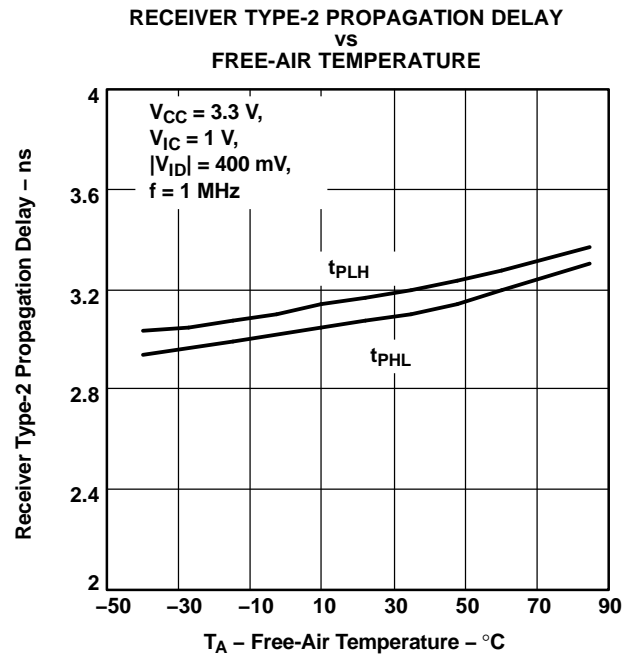
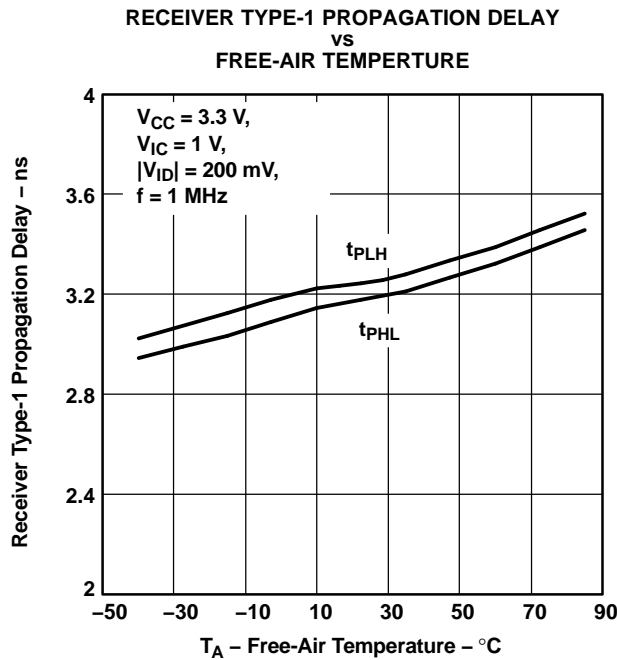
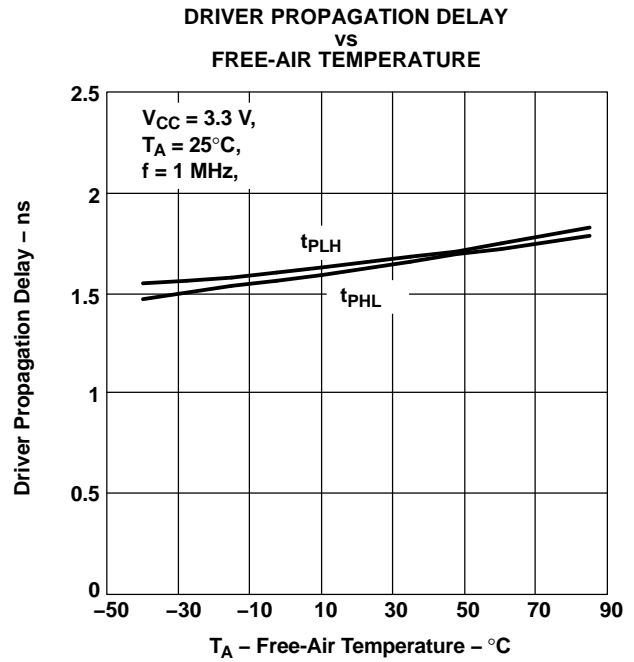
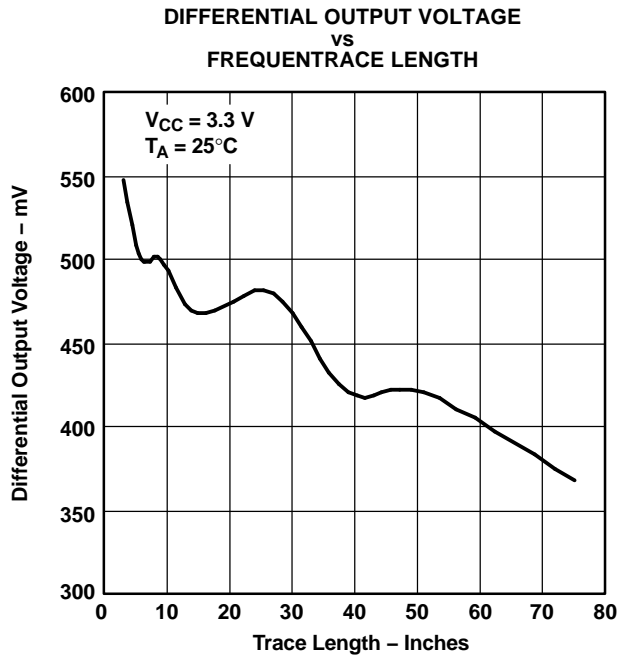
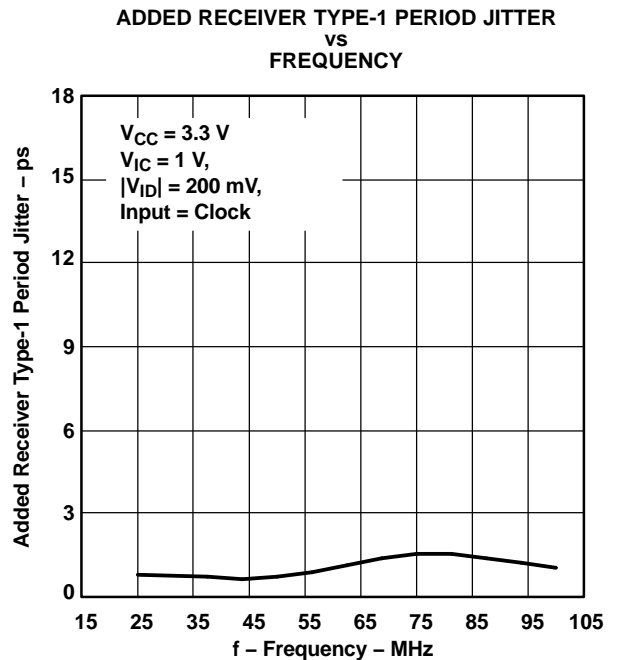
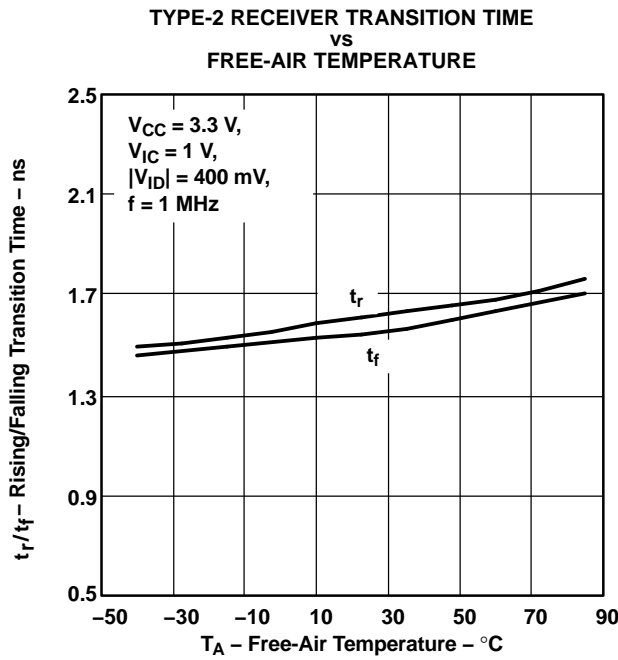
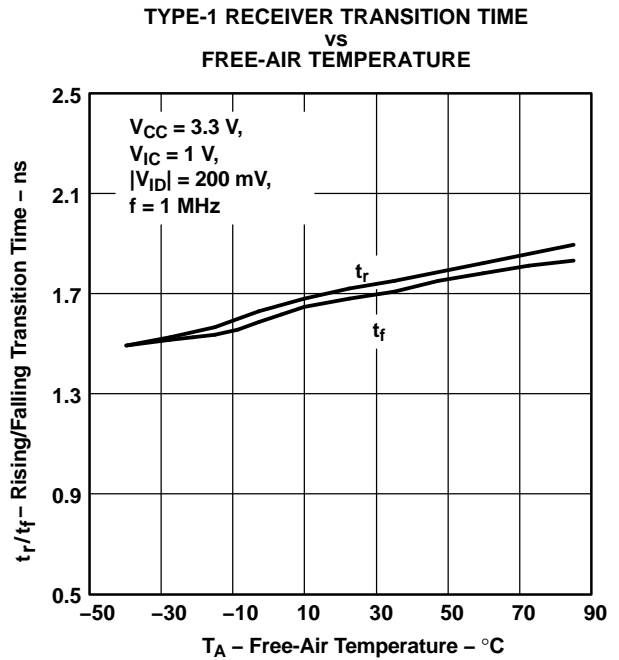
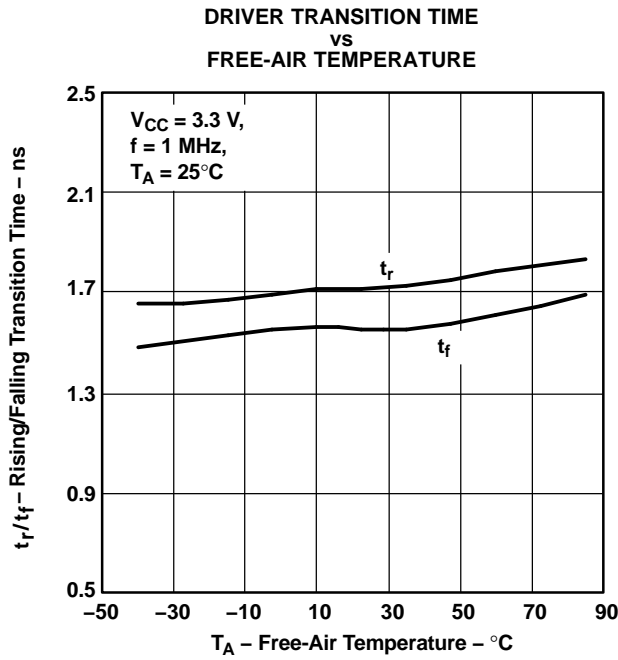

Figure 16.

TYPICAL CHARACTERISTICS (continued)



TYPICAL CHARACTERISTICS (continued)



TYPICAL CHARACTERISTICS (continued)

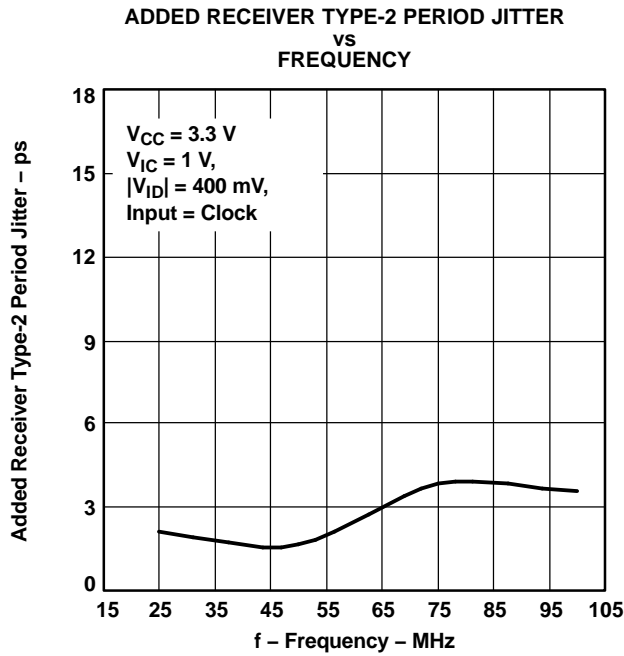

Figure 25.

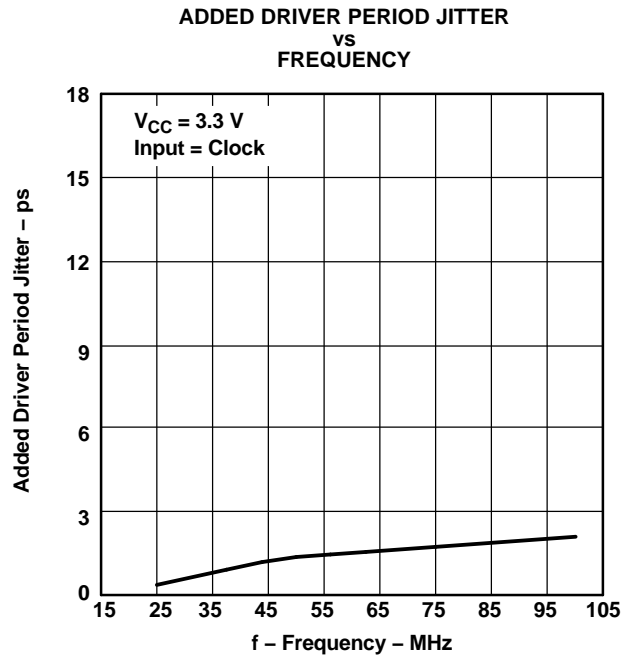

Figure 26.

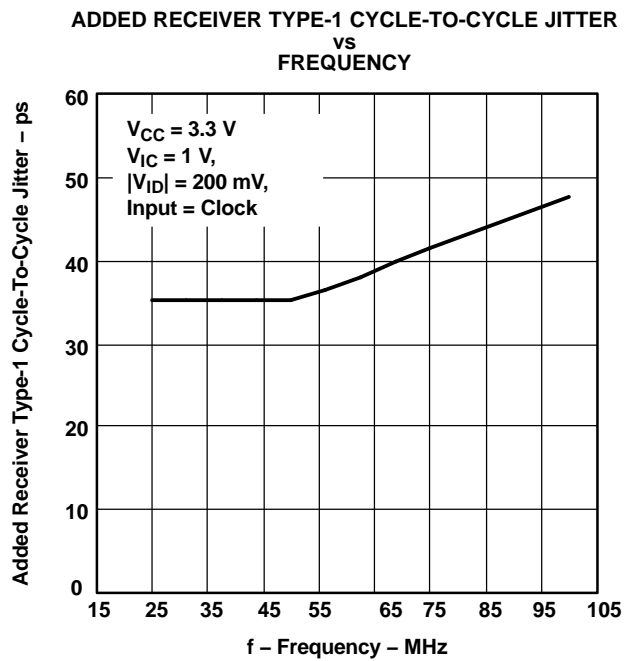

Figure 27.

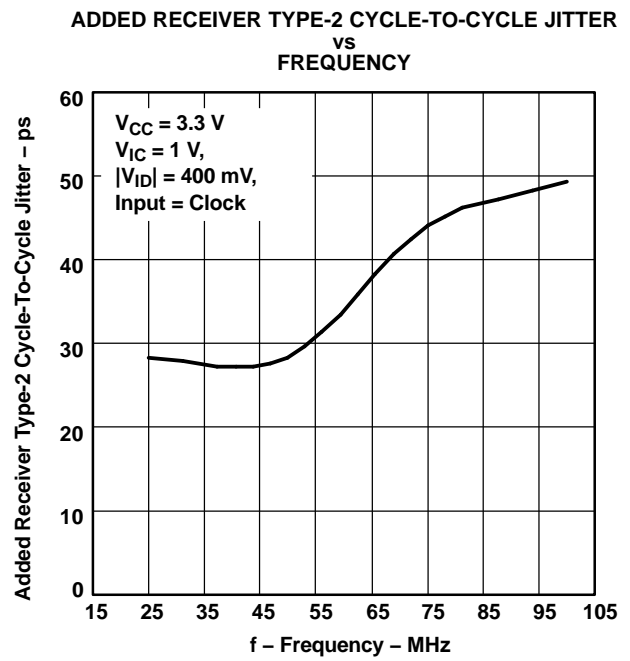

Figure 28.

TYPICAL CHARACTERISTICS (continued)

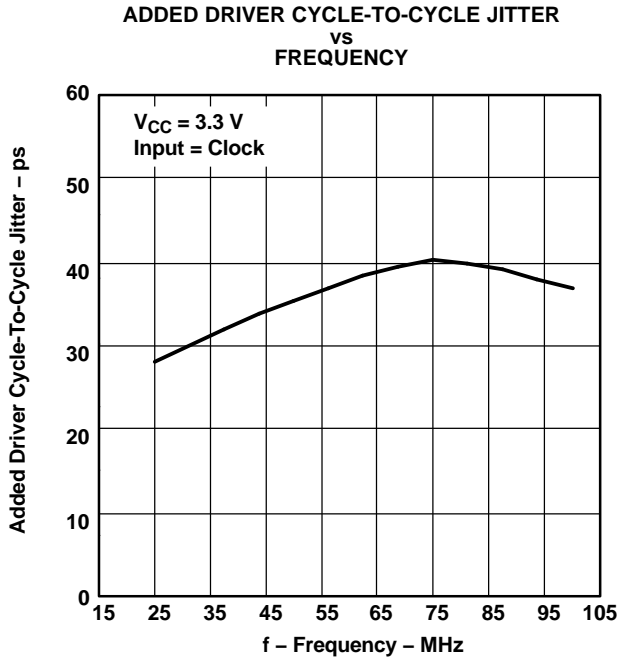

Figure 29.

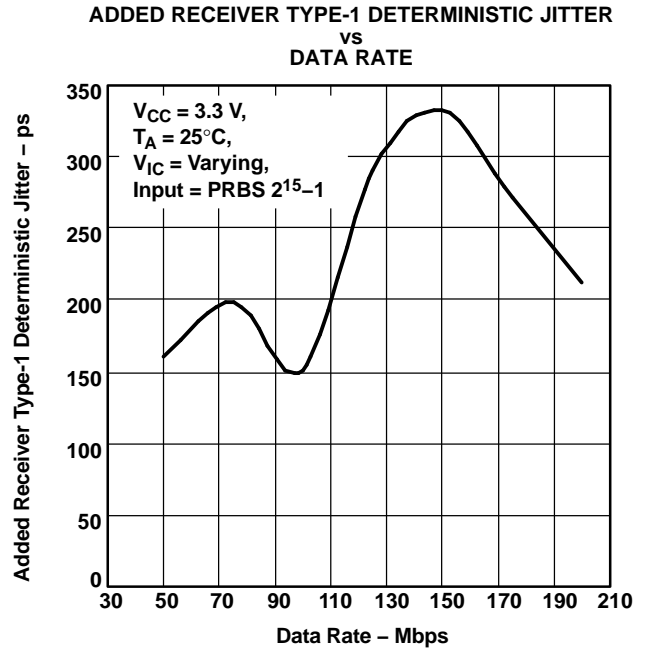

Figure 30.

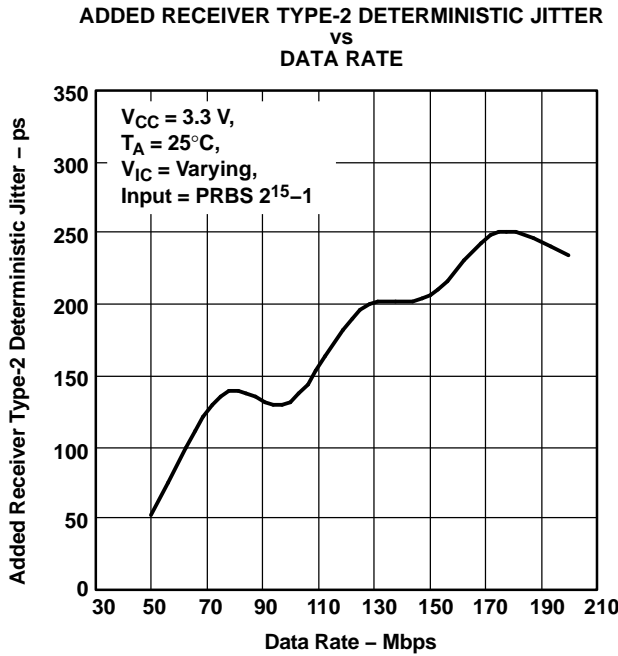

Figure 31.

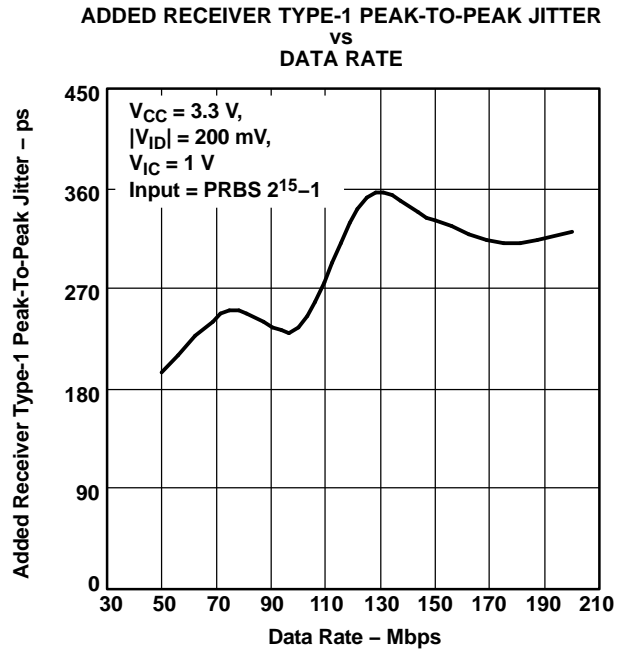

Figure 32.

TYPICAL CHARACTERISTICS (continued)

ADDED RECEIVER TYPE-2 PEAK-TO-PEAK JITTER
VS
DATA RATE

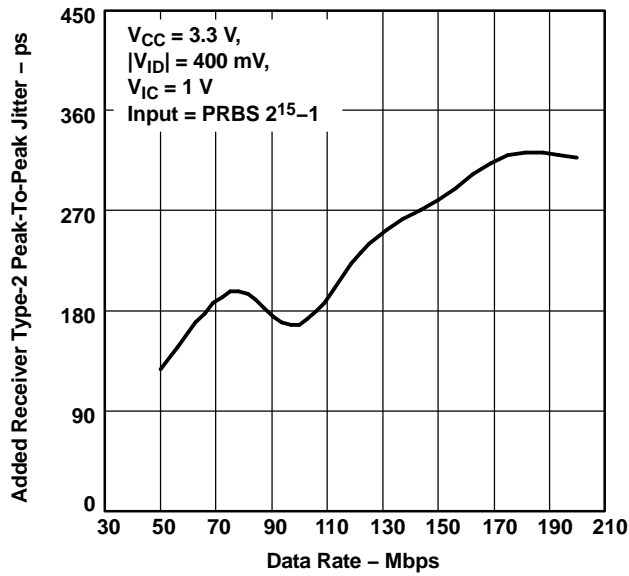

Figure 33.

ADDED DRIVER PEAK-TO-PEAK JITTER
VS
DATA RATE

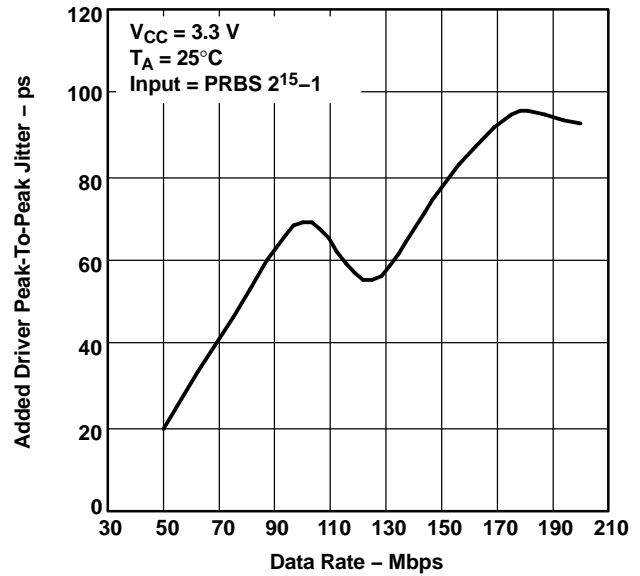

Figure 34.

DRIVER OUTPUT EYE PATTERN
200 Mbps, 2¹⁵-1 PRBS, V_{CC} = 3.3 V

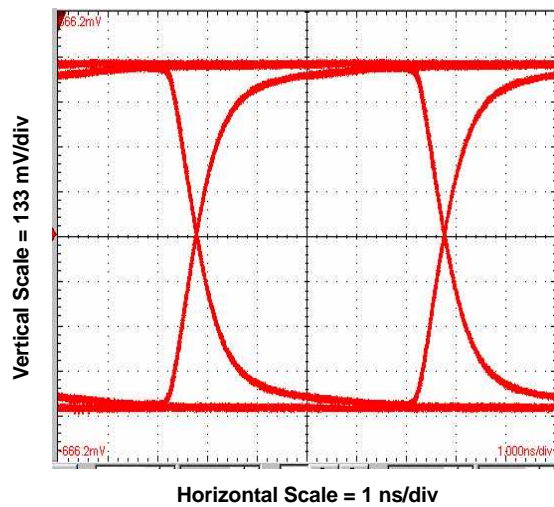

Figure 35.

RECEIVER OUTPUT EYE PATTERN
200 Mbps, 2¹⁵-1 PRBS, V_{CC} = 3.3 V
|V_{ID}| = 200 mV, V_{IC} = 1 V

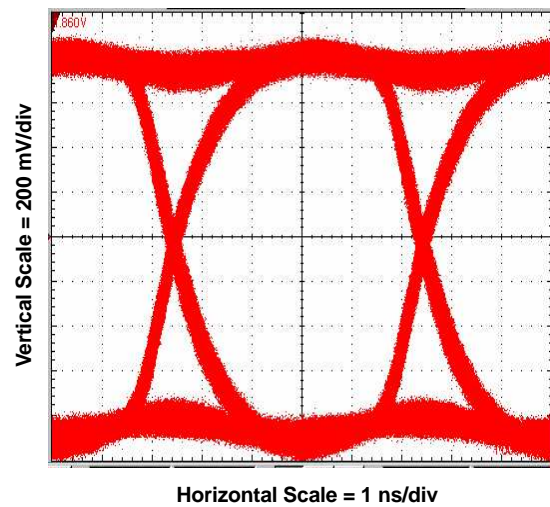

Figure 36.

APPLICATION INFORMATION

Source Synchronous System Clock (SSSC)

There are two approaches to transmit data in a synchronous system: centralized synchronous system clock (CSSC) and source synchronous system clock (SSSC). CSSC systems synchronize data transmission between different modules using a clock signal from a centralized source. The key requirement for a CSSC system is for data transmission and reception to complete during a single clock cycle. The maximum operating frequency is the inverse of the shortest clock cycle for which valid data transmission and reception can be ensured. SSSC systems achieve higher operating frequencies by sending clock and data signals together to eliminate the flight time on the transmission media, backplane, or cables. In SSSC systems, the maximum operating frequency is limited by the cumulated skews that can exist between clock and data. The absolute flight time of data on the backplane does not provide a limitation on the operating frequency as it does with CSSC.

The SN65MLVD082 can be designed for interfacing the data and clock to support source synchronous system clock (SSSC) operation. It is specified for transmitting data up to 250 Mbps and clock frequencies up to 125 MHz. The figure below shows an example of a SSSC architecture supported by M-LVDS transceivers. The SN65MLVD206, a single channel transceiver, transmits the main system clock between modules. A retiming unit is then applied to the main system clock to generate a local clock for subsystem synchronization processing. System operating data (or control) and subsystem clock signals are generated from the data processing unit, such as a microprocessor, FPGA, or ASIC, on module 1, and sent to slave modules through the SN65MLVD082. Such design configurations are common while transmitting parallel control data over the backplane with a higher SSSC subsystem clock frequency. The subsystem clock frequency is aligned with the operating frequencies of the data processing unit to synchronize data transmission between different units.

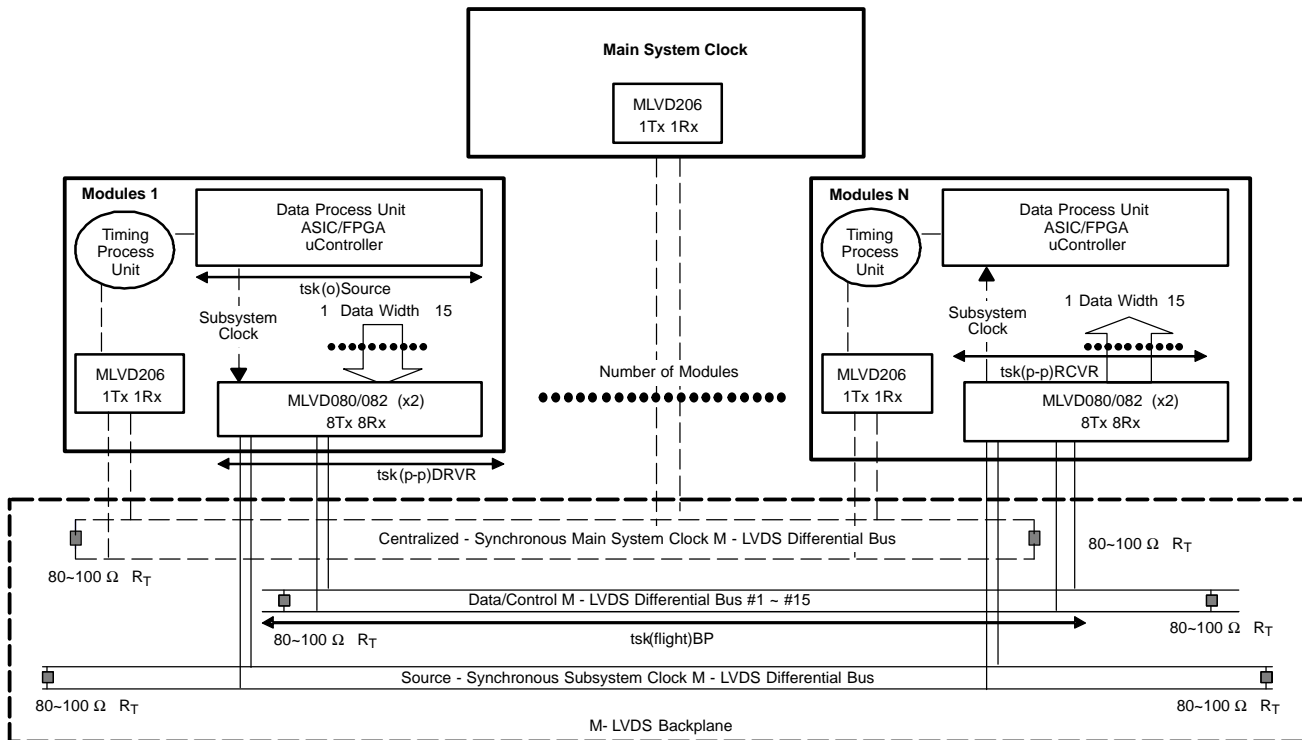

Figure 37. Using Differential M-LVDS to Perform Source Synchronous System Clock Distribution

The maximum SSSC frequencies in a transparent mode can be calculated with the following equation:

$$f_{\max(\text{clk})} < 1 / [t_{\text{sk(o)Source}} + t_{\text{sk(p-p)DRVR}} + t_{\text{sk(flight)BP}} + t_{\text{sk(p-p)RCVR}}]$$

Setup time and hold time on the receiver side are decided by the data processing unit, FPGA, or ASIC in this example. By considering data passes through the transceiver only, the general calculation result is 238 MHz when using the following data:

APPLICATION INFORMATION (continued)

$t_{sk(o)Source} = 2.0$ ns – Output skew of data processing unit; any skew between data bits, or clock and data bits

$t_{sk(p-p)DRVR} = 0.6$ ns – Driver part-to-part skew of the SN65MLVD082

$t_{sk(flight)BP} = 0.4$ ns – Skew of propagation delay on the backplane between data and clock

$t_{sk(p-p)RCVR} = 1.0$ ns – Receiver part-to-part skew of the SN65MLVD082

The 238-MHz maximum operating speed calculated above was determined based on data and clock skews only. Another important consideration when calculating the maximum operating speed is output transition time. Transition-time-limited operating speed can be calculated from the following formula:

$$f = 45\% \times \frac{1}{2 \times t_{transition}} \quad (1)$$

Using the typical transition time of the SN65MLVD082 of 1.4 ns, a transition-time-limited operating frequency of 170 MHz can be supported.

In addition to the high operating frequencies of SSSC that can be ensured, the SN65MLVD082 presents other benefits as other M-LVDS bus transceivers can provide:

- Robust system operation due to common mode noise cancellation using a low voltage differential receiver
- Low EMI radiation noise due to differential signaling improves signal integrity through the backplane
- A singly terminated transmission line is easy to design and implement
- Low power consumption in both active and idle modes minimizes thermal concerns on each module

In dense backplane design, these benefits are important for improving the performance of the whole system.

A similar result can be achieved with the SN65MLVD080.

APPLICATION INFORMATION (continued)

LIVE INSERTION/GLITCH-FREE POWER UP/DOWN

The SN65MLVD080/082 family of products offered by Texas Instruments provides a glitch-free powerup/down feature that prevents the M-LVDS outputs of the device from turning on during a powerup or powerdown event. This is especially important in live insertion applications, when a device is physically connected to an M-LVDS multipoint bus and VCC is ramping.

While the M-LVDS interface for these devices is glitch free on powerup/down, the receiver output structure is not. [Figure 38](#) shows the performance of the receiver output pin, R (CHANNEL 2), as Vcc (CHANNEL 1) is ramped.

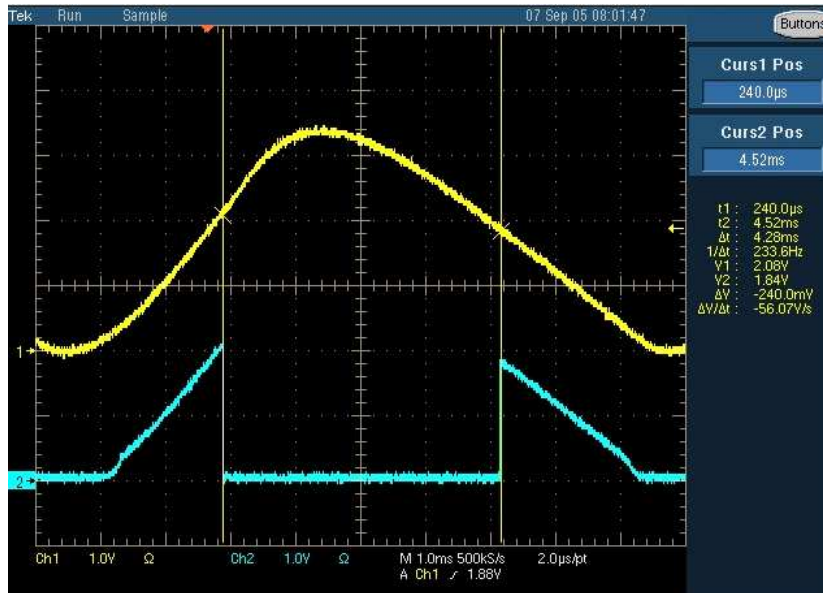

Figure 38. M-LVDS Receiver Output: VCC (CHANNEL 1), R Pin (CHANNEL 2)

The glitch on the R pin is independent of the \overline{RE} voltage. Any complications or issues from this glitch are easily resolved in power sequencing or system requirements that suspend operation until VCC has reached a steady state value.

PACKAGING INFORMATION

Orderable Device	Status (1)	Package Type	Package Drawing	Pins	Package Qty	Eco Plan (2)	Lead/Ball Finish (6)	MSL Peak Temp (3)	Op Temp (°C)	Device Marking (4/5)	Samples
SN65MLVD080DGG	ACTIVE	TSSOP	DGG	64	25	Green (RoHS & no Sb/Br)	CU NIPDAU	Level-2-260C-1 YEAR	-40 to 85	MLVD080	Samples
SN65MLVD080DGGG4	ACTIVE	TSSOP	DGG	64	25	Green (RoHS & no Sb/Br)	CU NIPDAU	Level-2-260C-1 YEAR	-40 to 85	MLVD080	Samples
SN65MLVD080DGGGR	ACTIVE	TSSOP	DGG	64	2000	Green (RoHS & no Sb/Br)	CU NIPDAU	Level-2-260C-1 YEAR	-40 to 85	MLVD080	Samples
SN65MLVD080DGGRG4	ACTIVE	TSSOP	DGG	64	2000	Green (RoHS & no Sb/Br)	CU NIPDAU	Level-2-260C-1 YEAR	-40 to 85	MLVD080	Samples
SN65MLVD082DGG	ACTIVE	TSSOP	DGG	64	25	Green (RoHS & no Sb/Br)	CU NIPDAU	Level-2-260C-1 YEAR	-40 to 85	MLVD082	Samples
SN65MLVD082DGGG4	ACTIVE	TSSOP	DGG	64	25	Green (RoHS & no Sb/Br)	CU NIPDAU	Level-2-260C-1 YEAR	-40 to 85	MLVD082	Samples
SN65MLVD082DGGGR	ACTIVE	TSSOP	DGG	64	2000	Green (RoHS & no Sb/Br)	CU NIPDAU	Level-2-260C-1 YEAR	-40 to 85	MLVD082	Samples

(1) The marketing status values are defined as follows:

ACTIVE: Product device recommended for new designs.

LIFEBUY: TI has announced that the device will be discontinued, and a lifetime-buy period is in effect.

NRND: Not recommended for new designs. Device is in production to support existing customers, but TI does not recommend using this part in a new design.

PREVIEW: Device has been announced but is not in production. Samples may or may not be available.

OBSOLETE: TI has discontinued the production of the device.

(2) **RoHS:** TI defines "RoHS" to mean semiconductor products that are compliant with the current EU RoHS requirements for all 10 RoHS substances, including the requirement that RoHS substance do not exceed 0.1% by weight in homogeneous materials. Where designed to be soldered at high temperatures, "RoHS" products are suitable for use in specified lead-free processes. TI may reference these types of products as "Pb-Free".

RoHS Exempt: TI defines "RoHS Exempt" to mean products that contain lead but are compliant with EU RoHS pursuant to a specific EU RoHS exemption.

Green: TI defines "Green" to mean the content of Chlorine (Cl) and Bromine (Br) based flame retardants meet JS709B low halogen requirements of <=100ppm threshold. Antimony trioxide based flame retardants must also meet the <=1000ppm threshold requirement.

(3) MSL, Peak Temp. - The Moisture Sensitivity Level rating according to the JEDEC industry standard classifications, and peak solder temperature.

(4) There may be additional marking, which relates to the logo, the lot trace code information, or the environmental category on the device.

(5) Multiple Device Markings will be inside parentheses. Only one Device Marking contained in parentheses and separated by a "-" will appear on a device. If a line is indented then it is a continuation of the previous line and the two combined represent the entire Device Marking for that device.

⁽⁶⁾ Lead/Ball Finish - Orderable Devices may have multiple material finish options. Finish options are separated by a vertical ruled line. Lead/Ball Finish values may wrap to two lines if the finish value exceeds the maximum column width.

Important Information and Disclaimer: The information provided on this page represents TI's knowledge and belief as of the date that it is provided. TI bases its knowledge and belief on information provided by third parties, and makes no representation or warranty as to the accuracy of such information. Efforts are underway to better integrate information from third parties. TI has taken and continues to take reasonable steps to provide representative and accurate information but may not have conducted destructive testing or chemical analysis on incoming materials and chemicals. TI and TI suppliers consider certain information to be proprietary, and thus CAS numbers and other limited information may not be available for release.

In no event shall TI's liability arising out of such information exceed the total purchase price of the TI part(s) at issue in this document sold by TI to Customer on an annual basis.

TAPE AND REEL INFORMATION



QUADRANT ASSIGNMENTS FOR PIN 1 ORIENTATION IN TAPE



*All dimensions are nominal

Device	Package Type	Package Drawing	Pins	SPQ	Reel Diameter (mm)	Reel Width W1 (mm)	A0 (mm)	B0 (mm)	K0 (mm)	P1 (mm)	W (mm)	Pin1 Quadrant
SN65MLVD080DGGR	TSSOP	DGG	64	2000	330.0	24.4	8.4	17.3	1.7	12.0	24.0	Q1
SN65MLVD082DGGR	TSSOP	DGG	64	2000	330.0	24.4	8.4	17.3	1.7	12.0	24.0	Q1

TAPE AND REEL BOX DIMENSIONS



*All dimensions are nominal

Device	Package Type	Package Drawing	Pins	SPQ	Length (mm)	Width (mm)	Height (mm)
SN65MLVD080DGGR	TSSOP	DGG	64	2000	350.0	350.0	43.0
SN65MLVD082DGGR	TSSOP	DGG	64	2000	350.0	350.0	43.0

DGG (R-PDSO-G**)

PLASTIC SMALL-OUTLINE PACKAGE

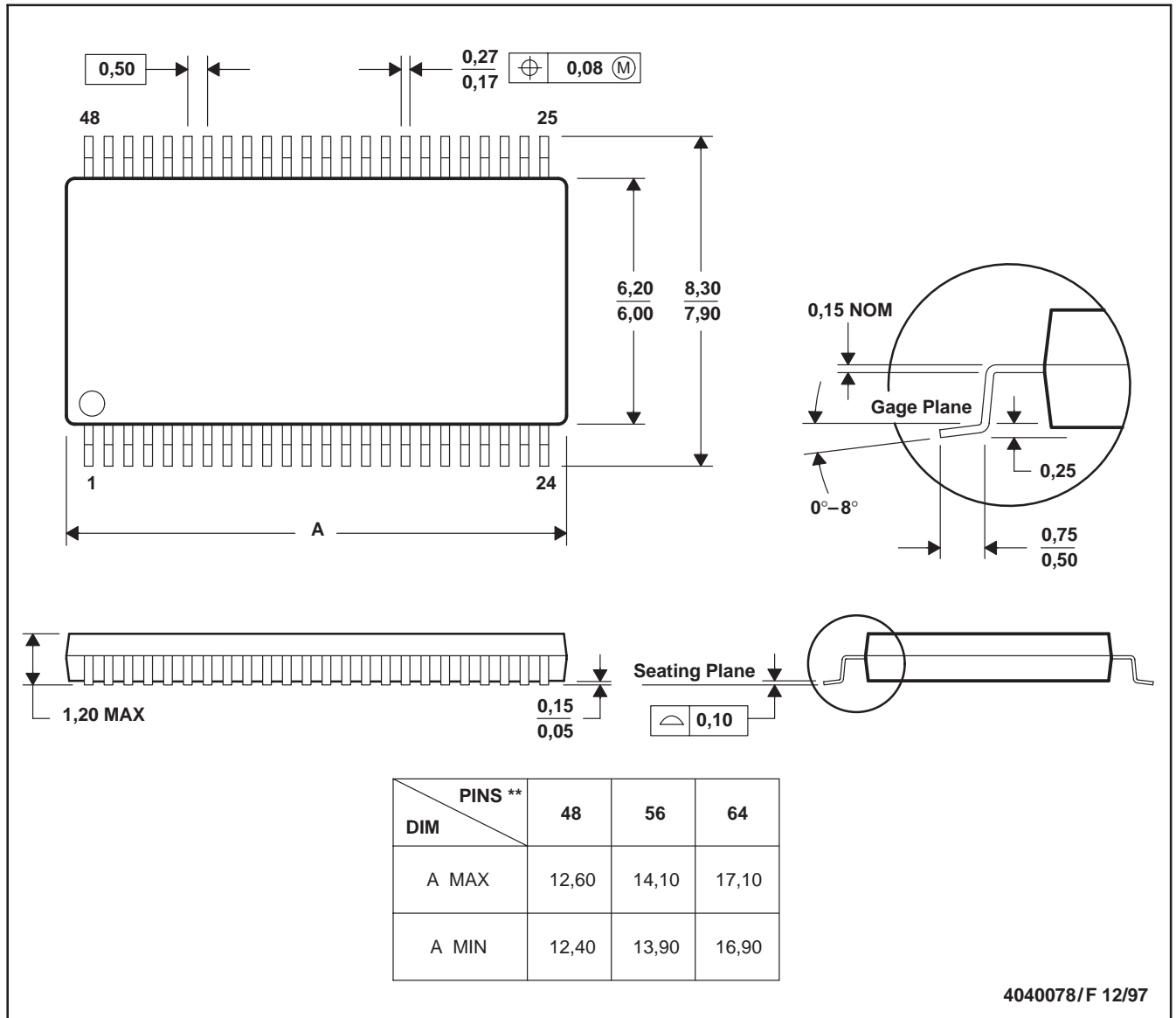
48 PINS SHOWN



- NOTES: A. All linear dimensions are in millimeters.
 B. This drawing is subject to change without notice.
 C. Body dimensions do not include mold protrusion not to exceed 0,15.
 D. Falls within JEDEC MO-153

IMPORTANT NOTICE AND DISCLAIMER

TI PROVIDES TECHNICAL AND RELIABILITY DATA (INCLUDING DATASHEETS), DESIGN RESOURCES (INCLUDING REFERENCE DESIGNS), APPLICATION OR OTHER DESIGN ADVICE, WEB TOOLS, SAFETY INFORMATION, AND OTHER RESOURCES "AS IS" AND WITH ALL FAULTS, AND DISCLAIMS ALL WARRANTIES, EXPRESS AND IMPLIED, INCLUDING WITHOUT LIMITATION ANY IMPLIED WARRANTIES OF MERCHANTABILITY, FITNESS FOR A PARTICULAR PURPOSE OR NON-INFRINGEMENT OF THIRD PARTY INTELLECTUAL PROPERTY RIGHTS.

These resources are intended for skilled developers designing with TI products. You are solely responsible for (1) selecting the appropriate TI products for your application, (2) designing, validating and testing your application, and (3) ensuring your application meets applicable standards, and any other safety, security, or other requirements. These resources are subject to change without notice. TI grants you permission to use these resources only for development of an application that uses the TI products described in the resource. Other reproduction and display of these resources is prohibited. No license is granted to any other TI intellectual property right or to any third party intellectual property right. TI disclaims responsibility for, and you will fully indemnify TI and its representatives against, any claims, damages, costs, losses, and liabilities arising out of your use of these resources.

TI's products are provided subject to TI's Terms of Sale (www.ti.com/legal/termsofsale.html) or other applicable terms available either on ti.com or provided in conjunction with such TI products. TI's provision of these resources does not expand or otherwise alter TI's applicable warranties or warranty disclaimers for TI products.

Mailing Address: Texas Instruments, Post Office Box 655303, Dallas, Texas 75265
Copyright © 2019, Texas Instruments Incorporated

Looking for pricing, stock, or lifecycle information?

Click below to explore more details on WIN SOURCE:

 [View SN65MLVD080DGGR on WIN SOURCE](#)

 [Texas Instruments](#) Information

Optimize Your Supply Chain with WIN SOURCE Solutions

-  Global Sourcing Solution
-  Obsolete Management
-  Cost Control Management
-  Shortage Management
-  Alternative Solution
-  Excess Inventory Management