



**THE DATASHEET OF
SN74GTL2107PWRG4**



FEATURES

- Operates as a GTL-/GTL/GTL+ to LVTTTL or LVTTTL to GTL-/GTL/GTL+ Translator
- Series Termination on TTL Output of 30 Ω
- Latch-Up Testing Done to JEDEC Standard JESD 78
- ESD Performance Tested Per JESD 22
 - 2000-V Human-Body Model (A114-B, Class II)
 - 200-V Machine Model (A115-A)
 - 1000-V Charged-Device Model (C101)

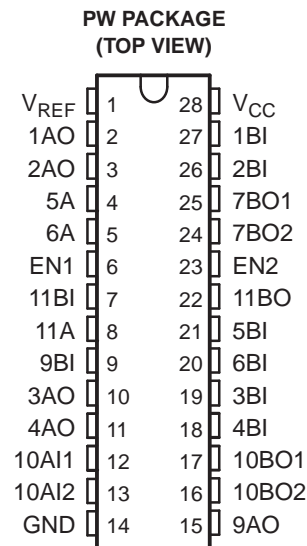

DESCRIPTION/ORDERING INFORMATION

The SN74GTL2107 is a 12-bit translator that interfaces between the 3.3-V LVTTTL chip set I/O and the Xeon™ processor GTL-/GTL/GTL+ I/O. The device is designed for platform health management in dual-processor applications.

PIN DESCRIPTION

PIN NO.	SYMBOL	NAME AND FUNCTION
1	V _{REF}	GTL reference voltage
2–6, 8, 10–13, 15, 23	EN _n nAn	Data and enable inputs/outputs (LVTTTL) on all inputs and pin 15 output. Remaining outputs are open drain.
7, 9, 16, 17–22, 24–27	nB _n	Data inputs/outputs (GTL-/GTL/GTL+)
14	GND	Ground (0 V)
28	V _{CC}	Positive supply voltage

ORDERING INFORMATION

T _A	PACKAGE ⁽¹⁾	ORDERABLE PART NUMBER	TOP-SIDE MARKING
–40°C to 85°C	TSSOP – PW	Tube	GK2107
		Tape and reel	

(1) Package drawings, standard packing quantities, thermal data, symbolization, and PCB design guidelines are available at www.ti.com/sc/package.



Please be aware that an important notice concerning availability, standard warranty, and use in critical applications of Texas Instruments semiconductor products and disclaimers thereto appears at the end of this data sheet.

Xeon is a trademark of Intel Corporation.

FUNCTION TABLES⁽¹⁾

INPUTS		OUTPUT 1AO/2AO (OPEN DRAIN)
EN1	1BI/2BI	
H	L	L
H	H	H
L	X	H

(1) H = High voltage level, L = Low voltage level

INPUTS		OUTPUT 3AO/4AO (OPEN DRAIN)
EN2	3BI/4BI	
H	L	L
H	H	H
L	X	H

INPUT 9BI	OUTPUT 9AO
L	L
H	H

INPUTS		OUTPUT 10BO1/10BO2
10AI1/10AI2	9BI	
L	L	L
L	H	L
H	L	L
H	H	H

INPUTS		INPUT/OUTPUT 5A/6A (OPEN DRAIN)	OUTPUT 7BO1/7BO2
EN2	5BI/6BI		
H	L	L	H ⁽¹⁾
H	H	L ⁽²⁾	L
H	H	H	H
L	H	L ⁽²⁾	L
L	H	H	H
L	L	H	H
L	L	L ⁽²⁾	H

- (1) The enable on 7BO1/7BO2 includes a delay that prevents a transient condition (where 5BI/6BI goes from low to high, and the low to high on 5A/6A lags up to 100 ns) from causing a low glitch on the 7BO1/7BO2 outputs.
- (2) Open-drain input/output terminal is driven to a logic-low state by an external driver.

INPUT 11BI	INPUT/OUTPUT 11A (OPEN DRAIN)	OUTPUT 11BO
L	H	L
L	L ⁽¹⁾	H
H	L	H

- (1) Open-drain input/output terminal is driven to a logic-low state by an external driver.

LOGIC SYMBOL

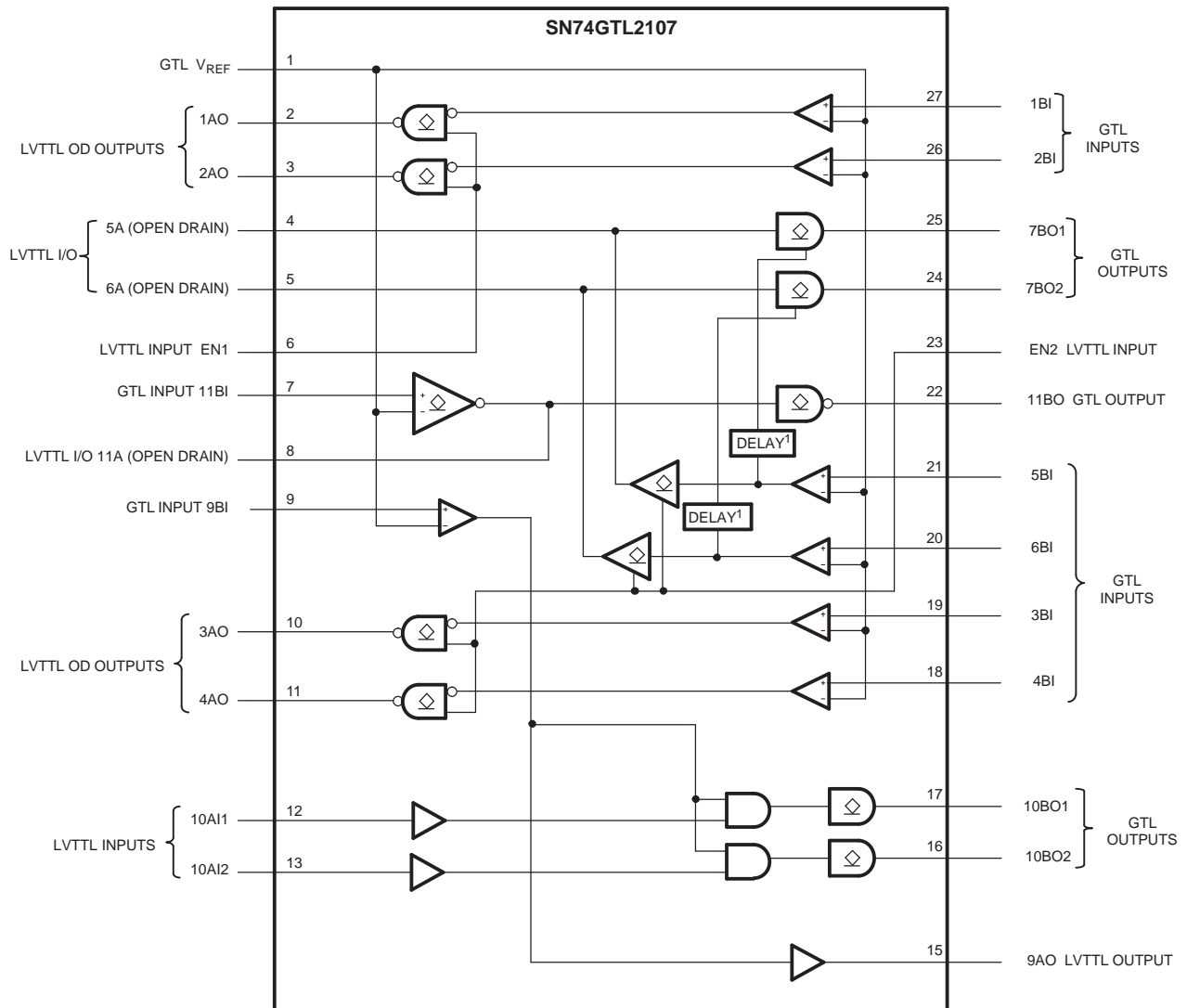

- (1) The enable on 7B01/7B02 includes a delay that prevents a transient condition (where 5BI/6BI go from low to high, and the low to high on 5A/6A lags up to 100 ns) from causing a low glitch on the 7B01/7B02 outputs.

SN74GTL2107

12-BIT GTL-/GTL/GTL+ TO LVTTTL TRANSLATOR

SCLS699–JULY 2006

Absolute Maximum Ratings⁽¹⁾⁽²⁾

over operating free-air temperature range (unless otherwise noted)

		MIN	MAX	UNIT	
V _{CC}	Supply voltage range	-0.5	4.6	V	
V _I	Input voltage range ⁽³⁾	A port (LVTTTL)	-0.5	4.6	V
		B port (GTL)	-0.5	4.6	
V _O	Output voltage range (output in OFF or HIGH state) ⁽³⁾	A port	-0.5	4.6	V
		B port	-0.5	4.6	
I _{IK}	Input diode current	V _I < 0	-50	mA	
I _{OK}	Output diode current	V _O < 0	-50	mA	
	Current into any output in the LOW state	A port	32	mA	
		B port	30		
	Current into any output in the HIGH state	A port	-32	mA	
θ _{JA}	Package thermal impedance ⁽⁴⁾		62	°C/W	
T _{stg}	Storage temperature range	-60	150	°C	

- (1) Stresses beyond those listed under "absolute maximum ratings" may cause permanent damage to the device. These are stress ratings only, and functional operation of the device at these or any other conditions beyond those indicated under "recommended operating conditions" is not implied. Exposure to absolute-maximum-rated conditions for extended periods may affect device reliability.
- (2) Voltages are referenced to GND (ground = 0 V).
- (3) The input and output negative voltage ratings may be exceeded if the input and output clamp current ratings are observed.
- (4) The performance capability of a high-performance integrated circuit, in conjunction with its thermal environment, can create junction temperatures that are detrimental to reliability. The maximum junction temperature of this integrated circuit should not exceed 150°C.

Recommended Operating Conditions

		MIN	NOM	MAX	UNIT	
V _{CC}	Supply voltage	3	3.3	3.6	V	
V _{TT}	Termination voltage	GTL-	0.85	0.9	0.95	V
		GTL	1.14	1.2	1.26	
		GTL+	1.35	1.5	1.65	
V _{REF}	Reference voltage	Overall	0.5	2/3 V _{TT}	1.8	V
		GTL-	0.5	0.6	0.63	
		GTL	0.76	0.8	0.84	
		GTL+	0.87	1	1.1	
V _I	Input voltage	A port	0	3.3	3.6	V
		B port	0	V _{TT}	3.6	
V _{IH}	High-level input voltage	A port	2			V
		B port	V _{REF} + 50 mV			
V _{IL}	Low-level input voltage	A port			0.8	V
		B port			V _{REF} - 50 mV	
I _{OH}	High-level output current	A port		-16	mA	
I _{OL}	Low-level output current	A port		16	mA	
		B port		15		
T _A	Operating free-air temperature	-40		85	°C	

Electrical Characteristics

over recommended operating conditions

PARAMETER		TEST CONDITIONS	–40°C to 85°C			UNIT
			MIN	TYP ⁽¹⁾	MAX	
V _{OH} ⁽²⁾	A port	V _{CC} = 3 V to 3.6 V, I _{OH} = –100 μA	V _{CC} – 0.2			V
		V _{CC} = 3 V, I _{OH} = –16 mA	2.1			
V _{OL} ⁽²⁾	A port	V _{CC} = 3 V, I _{OL} = 16 mA	0.8			V
	B port	V _{CC} = 3 V, I _{OL} = 15 mA	0.4			
I _I	A port	V _{CC} = 3.6 V, V _I = V _{CC}	±1			μA
		V _{CC} = 3.6 V, V _I = 0 V	±1			
	B port	V _{CC} = 3.6 V, V _I = V _{TT} or GND	±1			
I _{CC}	A or B port	V _{CC} = 3.6 V, V _I = V _{CC} or GND, I _O = 0	12			mA
ΔI _{CC} ⁽³⁾	A port or control inputs	V _{CC} = 3.6 V, V _I = V _{CC} – 0.6 V	500			μA
C _{IO}	A port	V _O = 3 V or 0	5			pF
	B port	V _O = V _{TT} or 0	4			

(1) All typical values are at V_{CC} = 3.3 V, T_A = 25°C.

(2) The input and output voltage ratings may be exceeded if the input and output current ratings are observed.

(3) This is the increase in supply current for each input that is at the specified LVTTTL voltage, rather than V_{CC} or GND.

Switching Characteristics

over recommended operating free-air temperature range

PARAMETER		WAVEFORM	GTL–			GTL			GTL+			UNIT
			V _{CC} = 3.3 V ± 0.3 V V _{REF} = 0.6 V			V _{CC} = 3.3 V ± 0.3 V V _{REF} = 0.8 V			V _{CC} = 3.3 V ± 0.3 V V _{REF} = 1 V			
			MIN	TYP ⁽¹⁾	MAX	MIN	TYP ⁽¹⁾	MAX	MIN	TYP ⁽¹⁾	MAX	
t _{PLH}	An to Bn	1	2	4	8	2	4	8	2	4	8	ns
t _{PHL}			2	5.5	10	2	5.5	10	2	5.5	10	
t _{PLH}	9BI to 9AO	2	2	5.5	10	2	5.5	10	2	5.5	10	ns
t _{PHL}			2	5.5	10	2	5.5	10	2	5.5	10	
t _{PLH}	9BI to 10BOn	3	2	6	11	2	6	11	2	6	11	ns
t _{PHL}			2	6	11	2	6	11	2	6	11	
t _{PLH}	11BI to 11BO	3	2	8	13	2	8	13	2	8	13	ns
t _{PHL} ⁽²⁾			2	14	21	2	14	21	2	14	21	
t _{PLH}	Bn to Bn	3	4	7	11	4	7	11	4	7	11	ns
t _{PHL}			120	205	350	120	205	350	120	205	350	
t _{PLZ}	ENn to An	5	1	3	7	1	3	7	1	3	7	ns
t _{PZL}			1	3	7	1	3	7	1	3	7	
t _{PLZ}	Bn to An (I/O)	4	2	5	10	2	5	10	2	5	10	ns
t _{PZL}			2	5	10	2	5	10	2	5	10	
t _{PLZ}	Bn to An	4	2	5	10	2	5	10	2	5	10	ns
t _{PZL}			2	5	10	2	5	10	2	5	10	
t _{PLZ}	EN2 to An (I/O)	5	1	3	7	1	3	7	1	3	7	ns
t _{PZL}			1	3	7	1	3	7	1	3	7	

(1) All typical values are measured at V_{CC} = 3.3 V and T_A = 25°C.

(2) Includes –7.6-ns RC rise time of test-load pullup on 11 A, 1.5-kΩ pullup, and 21-pF load on 11 A has approximately 23-ns RC rise time.

PARAMETER MEASUREMENT INFORMATION
 $V_{TT} = 1.2\text{ V}$, $V_{REF} = 0.8\text{ V}$ for GTL and $V_{TT} = 1.5\text{ V}$, $V_{REF} = 1\text{ V}$ for GTL+

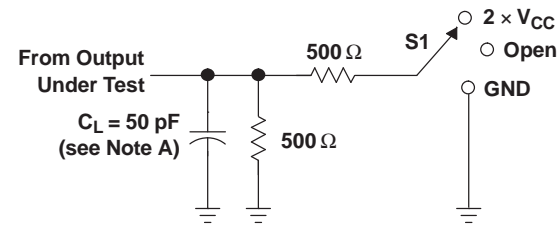

LOAD CIRCUIT FOR A OUTPUTS

TEST	S1
t_{PLH}/t_{PHL}	Open
t_{PLZ}/t_{PZL}	$2 \times V_{CC}$

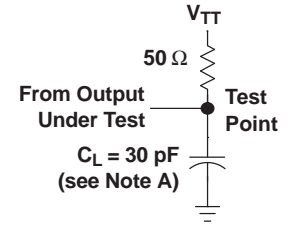

LOAD CIRCUIT FOR B OUTPUTS

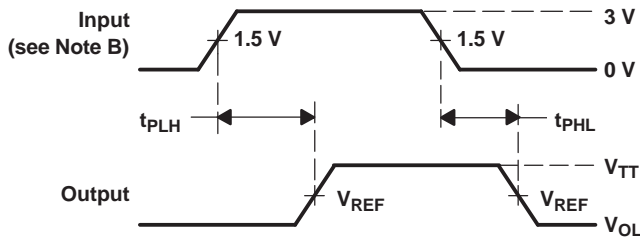

VOLTAGE WAVEFORM 1
PROPAGATION DELAY TIMES
(A port to B port)[†]

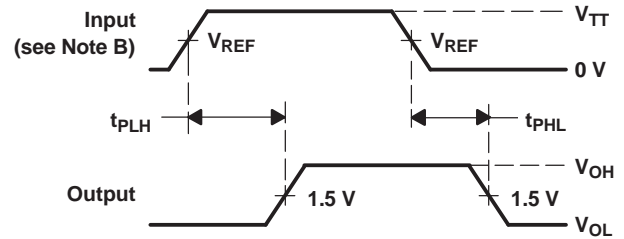

VOLTAGE WAVEFORM 2
PROPAGATION DELAY TIMES
(B port to A port)[†]

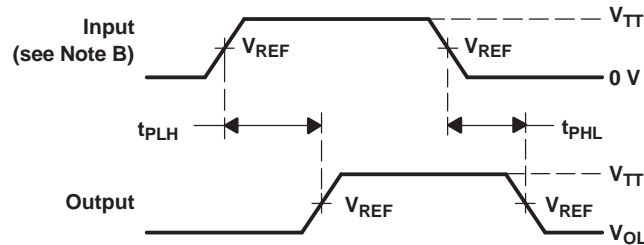

VOLTAGE WAVEFORM 3
PROPAGATION DELAY TIMES
(B port to B port)[†]

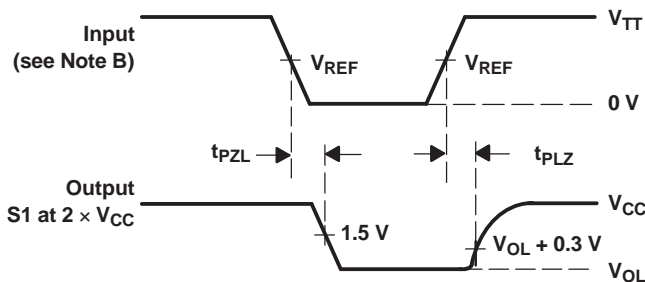

VOLTAGE WAVEFORM 4
PROPAGATION DELAY TIMES
(B port to A (I/O) port)[†]

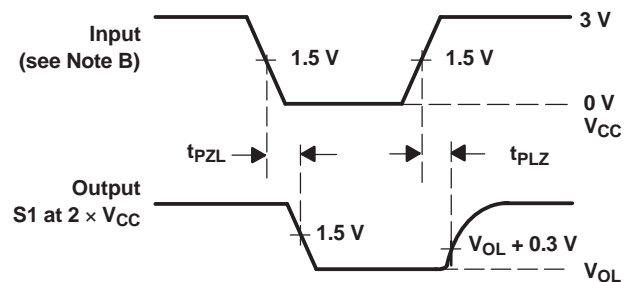

VOLTAGE WAVEFORM 5
ENABLE AND DISABLE TIMES
(EN2 to A(I/O) and ENn to An port)[†]

[†] All control inputs are LVTTL levels.

NOTES: A. C_L includes probe and jig capacitance.

B. All input pulses are supplied by generators having the following characteristics: PRR $\leq 10\text{ MHz}$, $Z_O = 50\ \Omega$, $t_r \leq 2.5\text{ ns}$, $t_f \leq 2.5\text{ ns}$.

C. The outputs are measured one at a time, with one transition per measurement.

Figure 1. Load Circuits and Voltage Waveforms

APPLICATION INFORMATION

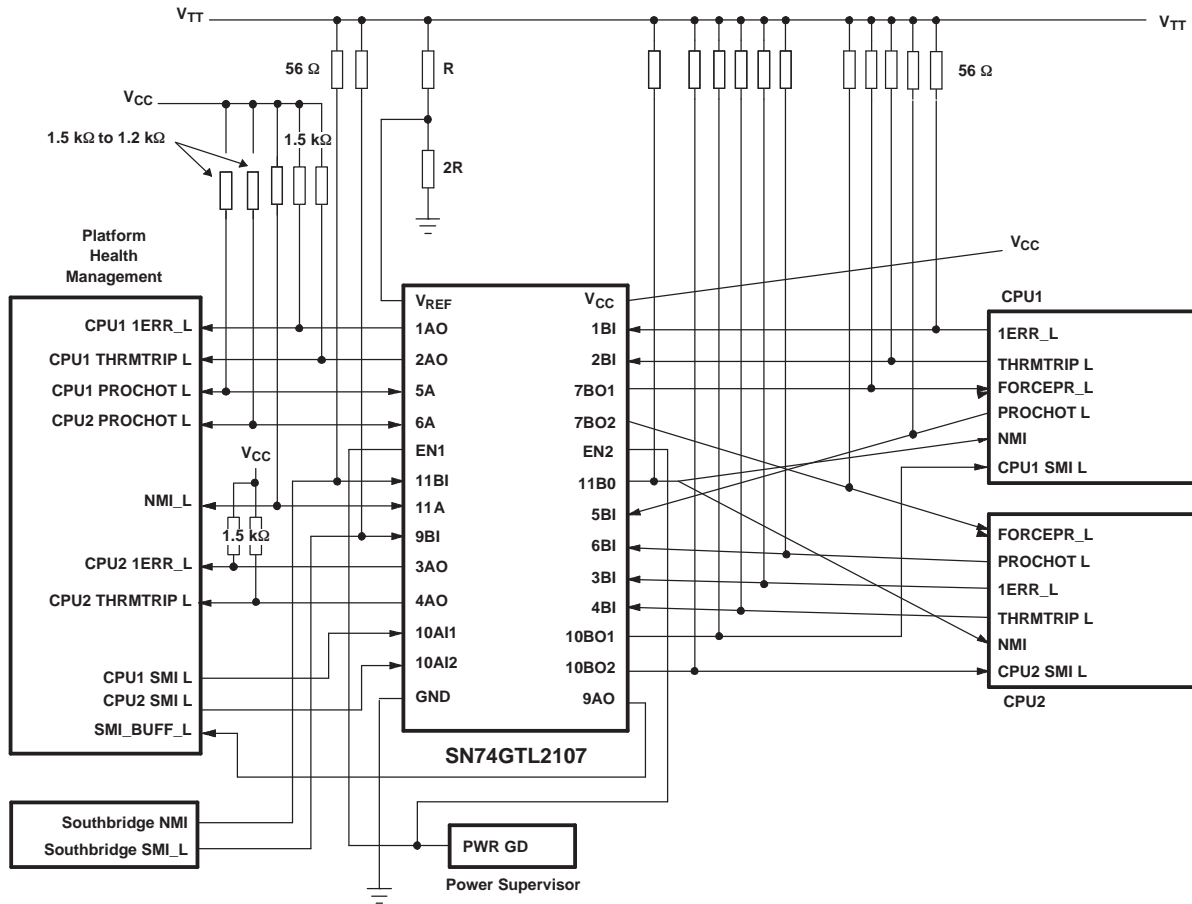

Frequently Asked Questions

Question 1: On the SN74GTL2107 LVTTL input, specifically 10AI1 and 10AI2, when the SN74GTL2107 is powered down, these inputs may be pulled up to 3.3 V, and we want to ensure that there is no leakage path to the power rail under this condition. Are the LVTTL inputs high impedance when the device is powered down, and will there be any leakage?

Answer 1: When the device is powered down, the LVTTL inputs are in a high-impedance state and do not leak to V_{DD} if they are pulled high while the device is powered down.

Question 2: Do all the LVTTL inputs have the same powered-down characteristic?

Answer 2: Yes

Question 3: What is the condition of the other GTL I/O and LVTTL output pins when the device is powered down?

Answer 3: The open-drain outputs, both GTL and LVTTL, do not leak to the power supply if they are pulled high while the device is powered down. The GTL inputs also do not leak to the power supply under the same conditions. The LVTTL totem-pole outputs, however, are not open-drain type outputs, and there is current flow on these pins if they are pulled high when V_{DD} is at ground.

PACKAGING INFORMATION

Orderable Device	Status (1)	Package Type	Package Drawing	Pins	Package Qty	Eco Plan (2)	Lead/Ball Finish (6)	MSL Peak Temp (3)	Op Temp (°C)	Device Marking (4/5)	Samples
SN74GTL2107PW	ACTIVE	TSSOP	PW	28	50	Green (RoHS & no Sb/Br)	CU NIPDAU	Level-1-260C-UNLIM	-40 to 85	GK2107	Samples
SN74GTL2107PWR	ACTIVE	TSSOP	PW	28	2000	Green (RoHS & no Sb/Br)	CU NIPDAU	Level-1-260C-UNLIM	-40 to 85	GK2107	Samples
SN74GTL2107PWRG4	ACTIVE	TSSOP	PW	28	2000	Green (RoHS & no Sb/Br)	CU NIPDAU	Level-1-260C-UNLIM	-40 to 85	GK2107	Samples

(1) The marketing status values are defined as follows:

ACTIVE: Product device recommended for new designs.

LIFEBUY: TI has announced that the device will be discontinued, and a lifetime-buy period is in effect.

NRND: Not recommended for new designs. Device is in production to support existing customers, but TI does not recommend using this part in a new design.

PREVIEW: Device has been announced but is not in production. Samples may or may not be available.

OBsolete: TI has discontinued the production of the device.

(2) **RoHS:** TI defines "RoHS" to mean semiconductor products that are compliant with the current EU RoHS requirements for all 10 RoHS substances, including the requirement that RoHS substance do not exceed 0.1% by weight in homogeneous materials. Where designed to be soldered at high temperatures, "RoHS" products are suitable for use in specified lead-free processes. TI may reference these types of products as "Pb-Free".

RoHS Exempt: TI defines "RoHS Exempt" to mean products that contain lead but are compliant with EU RoHS pursuant to a specific EU RoHS exemption.

Green: TI defines "Green" to mean the content of Chlorine (Cl) and Bromine (Br) based flame retardants meet JS709B low halogen requirements of <=1000ppm threshold. Antimony trioxide based flame retardants must also meet the <=1000ppm threshold requirement.

(3) MSL, Peak Temp. - The Moisture Sensitivity Level rating according to the JEDEC industry standard classifications, and peak solder temperature.

(4) There may be additional marking, which relates to the logo, the lot trace code information, or the environmental category on the device.

(5) Multiple Device Markings will be inside parentheses. Only one Device Marking contained in parentheses and separated by a "~" will appear on a device. If a line is indented then it is a continuation of the previous line and the two combined represent the entire Device Marking for that device.

(6) Lead/Ball Finish - Orderable Devices may have multiple material finish options. Finish options are separated by a vertical ruled line. Lead/Ball Finish values may wrap to two lines if the finish value exceeds the maximum column width.

Important Information and Disclaimer: The information provided on this page represents TI's knowledge and belief as of the date that it is provided. TI bases its knowledge and belief on information provided by third parties, and makes no representation or warranty as to the accuracy of such information. Efforts are underway to better integrate information from third parties. TI has taken and continues to take reasonable steps to provide representative and accurate information but may not have conducted destructive testing or chemical analysis on incoming materials and chemicals. TI and TI suppliers consider certain information to be proprietary, and thus CAS numbers and other limited information may not be available for release.

In no event shall TI's liability arising out of such information exceed the total purchase price of the TI part(s) at issue in this document sold by TI to Customer on an annual basis.

TAPE AND REEL INFORMATION



QUADRANT ASSIGNMENTS FOR PIN 1 ORIENTATION IN TAPE

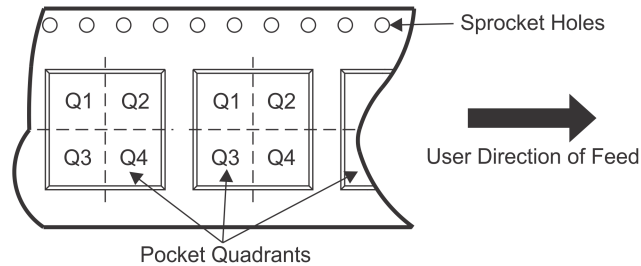

*All dimensions are nominal

Device	Package Type	Package Drawing	Pins	SPQ	Reel Diameter (mm)	Reel Width W1 (mm)	A0 (mm)	B0 (mm)	K0 (mm)	P1 (mm)	W (mm)	Pin1 Quadrant
SN74GTL2107PWR	TSSOP	PW	28	2000	330.0	16.4	6.9	10.2	1.8	12.0	16.0	Q1

TAPE AND REEL BOX DIMENSIONS



*All dimensions are nominal

Device	Package Type	Package Drawing	Pins	SPQ	Length (mm)	Width (mm)	Height (mm)
SN74GTL2107PWR	TSSOP	PW	28	2000	367.0	367.0	38.0

PW (R-PDSO-G28)

PLASTIC SMALL OUTLINE

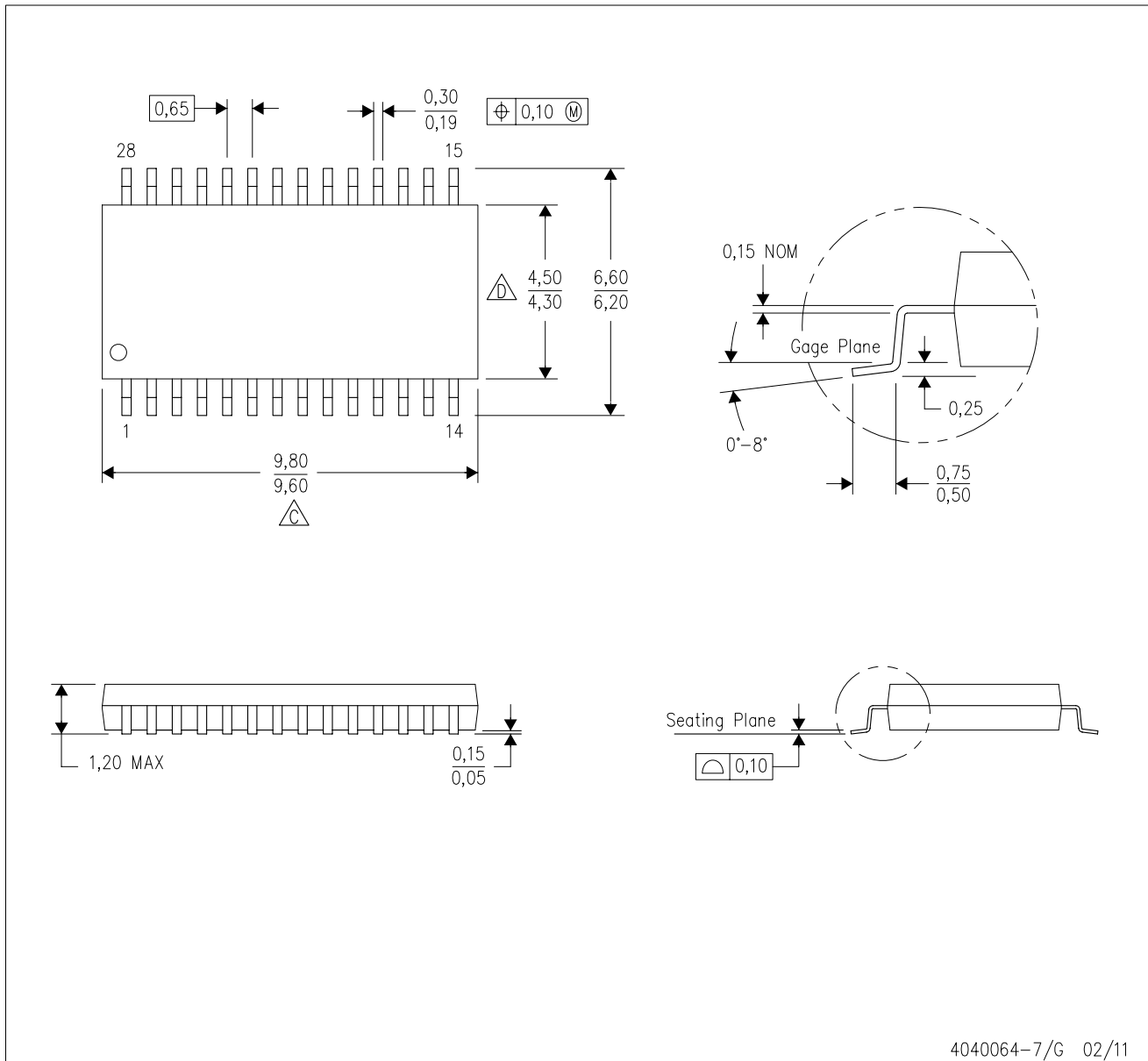

4040064-7/G 02/11

- NOTES:
- A. All linear dimensions are in millimeters. Dimensioning and tolerancing per ASME Y14.5M-1994.
 - B. This drawing is subject to change without notice.
 - C. Body length does not include mold flash, protrusions, or gate burrs. Mold flash, protrusions, or gate burrs shall not exceed 0,15 each side.
 - D. Body width does not include interlead flash. Interlead flash shall not exceed 0,25 each side.
 - E. Falls within JEDEC MO-153

PW (R-PDSO-G28)

PLASTIC SMALL OUTLINE

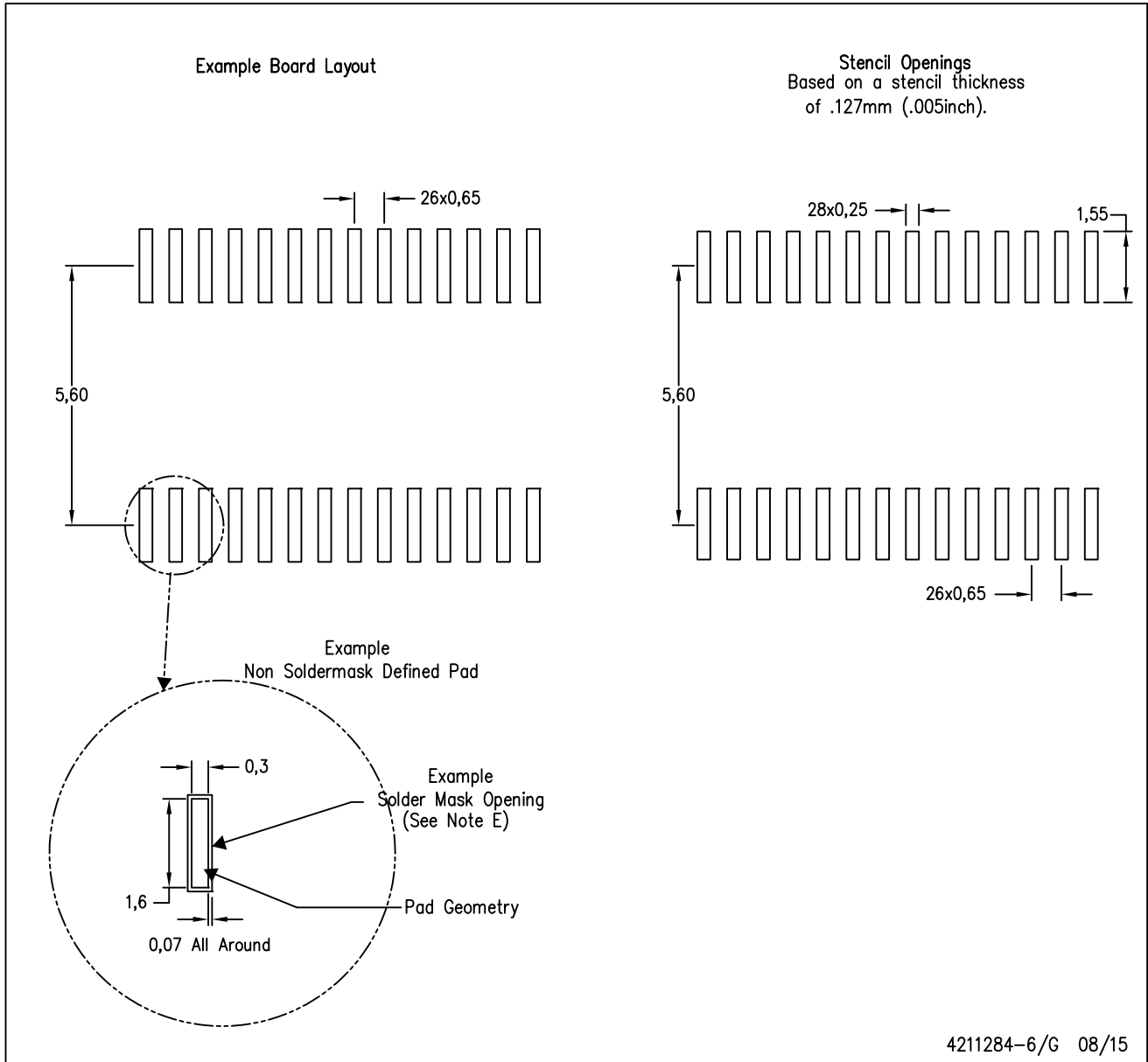

- NOTES:
- All linear dimensions are in millimeters.
 - This drawing is subject to change without notice.
 - Publication IPC-7351 is recommended for alternate design.
 - Laser cutting apertures with trapezoidal walls and also rounding corners will offer better paste release. Customers should contact their board assembly site for stencil design recommendations. Refer to IPC-7525 for other stencil recommendations.
 - Customers should contact their board fabrication site for solder mask tolerances between and around signal pads.

IMPORTANT NOTICE

Texas Instruments Incorporated (TI) reserves the right to make corrections, enhancements, improvements and other changes to its semiconductor products and services per JESD46, latest issue, and to discontinue any product or service per JESD48, latest issue. Buyers should obtain the latest relevant information before placing orders and should verify that such information is current and complete.

TI's published terms of sale for semiconductor products (<http://www.ti.com/sc/docs/stdterms.htm>) apply to the sale of packaged integrated circuit products that TI has qualified and released to market. Additional terms may apply to the use or sale of other types of TI products and services.

Reproduction of significant portions of TI information in TI data sheets is permissible only if reproduction is without alteration and is accompanied by all associated warranties, conditions, limitations, and notices. TI is not responsible or liable for such reproduced documentation. Information of third parties may be subject to additional restrictions. Resale of TI products or services with statements different from or beyond the parameters stated by TI for that product or service voids all express and any implied warranties for the associated TI product or service and is an unfair and deceptive business practice. TI is not responsible or liable for any such statements.

Buyers and others who are developing systems that incorporate TI products (collectively, "Designers") understand and agree that Designers remain responsible for using their independent analysis, evaluation and judgment in designing their applications and that Designers have full and exclusive responsibility to assure the safety of Designers' applications and compliance of their applications (and of all TI products used in or for Designers' applications) with all applicable regulations, laws and other applicable requirements. Designer represents that, with respect to their applications, Designer has all the necessary expertise to create and implement safeguards that (1) anticipate dangerous consequences of failures, (2) monitor failures and their consequences, and (3) lessen the likelihood of failures that might cause harm and take appropriate actions. Designer agrees that prior to using or distributing any applications that include TI products, Designer will thoroughly test such applications and the functionality of such TI products as used in such applications.

TI's provision of technical, application or other design advice, quality characterization, reliability data or other services or information, including, but not limited to, reference designs and materials relating to evaluation modules, (collectively, "TI Resources") are intended to assist designers who are developing applications that incorporate TI products; by downloading, accessing or using TI Resources in any way, Designer (individually or, if Designer is acting on behalf of a company, Designer's company) agrees to use any particular TI Resource solely for this purpose and subject to the terms of this Notice.

TI's provision of TI Resources does not expand or otherwise alter TI's applicable published warranties or warranty disclaimers for TI products, and no additional obligations or liabilities arise from TI providing such TI Resources. TI reserves the right to make corrections, enhancements, improvements and other changes to its TI Resources. TI has not conducted any testing other than that specifically described in the published documentation for a particular TI Resource.

Designer is authorized to use, copy and modify any individual TI Resource only in connection with the development of applications that include the TI product(s) identified in such TI Resource. NO OTHER LICENSE, EXPRESS OR IMPLIED, BY ESTOPPEL OR OTHERWISE TO ANY OTHER TI INTELLECTUAL PROPERTY RIGHT, AND NO LICENSE TO ANY TECHNOLOGY OR INTELLECTUAL PROPERTY RIGHT OF TI OR ANY THIRD PARTY IS GRANTED HEREIN, including but not limited to any patent right, copyright, mask work right, or other intellectual property right relating to any combination, machine, or process in which TI products or services are used. Information regarding or referencing third-party products or services does not constitute a license to use such products or services, or a warranty or endorsement thereof. Use of TI Resources may require a license from a third party under the patents or other intellectual property of the third party, or a license from TI under the patents or other intellectual property of TI.

TI RESOURCES ARE PROVIDED "AS IS" AND WITH ALL FAULTS. TI DISCLAIMS ALL OTHER WARRANTIES OR REPRESENTATIONS, EXPRESS OR IMPLIED, REGARDING RESOURCES OR USE THEREOF, INCLUDING BUT NOT LIMITED TO ACCURACY OR COMPLETENESS, TITLE, ANY EPIDEMIC FAILURE WARRANTY AND ANY IMPLIED WARRANTIES OF MERCHANTABILITY, FITNESS FOR A PARTICULAR PURPOSE, AND NON-INFRINGEMENT OF ANY THIRD PARTY INTELLECTUAL PROPERTY RIGHTS. TI SHALL NOT BE LIABLE FOR AND SHALL NOT DEFEND OR INDEMNIFY DESIGNER AGAINST ANY CLAIM, INCLUDING BUT NOT LIMITED TO ANY INFRINGEMENT CLAIM THAT RELATES TO OR IS BASED ON ANY COMBINATION OF PRODUCTS EVEN IF DESCRIBED IN TI RESOURCES OR OTHERWISE. IN NO EVENT SHALL TI BE LIABLE FOR ANY ACTUAL, DIRECT, SPECIAL, COLLATERAL, INDIRECT, PUNITIVE, INCIDENTAL, CONSEQUENTIAL OR EXEMPLARY DAMAGES IN CONNECTION WITH OR ARISING OUT OF TI RESOURCES OR USE THEREOF, AND REGARDLESS OF WHETHER TI HAS BEEN ADVISED OF THE POSSIBILITY OF SUCH DAMAGES.

Unless TI has explicitly designated an individual product as meeting the requirements of a particular industry standard (e.g., ISO/TS 16949 and ISO 26262), TI is not responsible for any failure to meet such industry standard requirements.

Where TI specifically promotes products as facilitating functional safety or as compliant with industry functional safety standards, such products are intended to help enable customers to design and create their own applications that meet applicable functional safety standards and requirements. Using products in an application does not by itself establish any safety features in the application. Designers must ensure compliance with safety-related requirements and standards applicable to their applications. Designer may not use any TI products in life-critical medical equipment unless authorized officers of the parties have executed a special contract specifically governing such use. Life-critical medical equipment is medical equipment where failure of such equipment would cause serious bodily injury or death (e.g., life support, pacemakers, defibrillators, heart pumps, neurostimulators, and implantables). Such equipment includes, without limitation, all medical devices identified by the U.S. Food and Drug Administration as Class III devices and equivalent classifications outside the U.S.

TI may expressly designate certain products as completing a particular qualification (e.g., Q100, Military Grade, or Enhanced Product). Designers agree that it has the necessary expertise to select the product with the appropriate qualification designation for their applications and that proper product selection is at Designers' own risk. Designers are solely responsible for compliance with all legal and regulatory requirements in connection with such selection.

Designer will fully indemnify TI and its representatives against any damages, costs, losses, and/or liabilities arising out of Designer's non-compliance with the terms and provisions of this Notice.

Looking for pricing, stock, or lifecycle information?

Click below to explore more details on WIN SOURCE:

 [View SN74GTL2107PWRG4 on WIN SOURCE](#)

 [Texas Instruments](#) Information

Optimize Your Supply Chain with WIN SOURCE Solutions

-  Global Sourcing Solution
-  Obsolete Management
-  Cost Control Management
-  Shortage Management
-  Alternative Solution
-  Excess Inventory Management