



**THE DATASHEET OF
SN65LVCP1414RLJT**



14.2-Gbps Quad Channel, Dual Mode Linear Equalizer

Check for Samples: [SN65LVCP1414](#)

FEATURES

- **Quad Channel, Uni-Directional, Multi-Rate, Dual-Mode Linear Equalizer with Operation up to 14.2Gbps Serial Data Rate for Backplane and Cable Interconnects**
- **Linear Equalization Increases Link Margin for Systems Implementing Decision Feedback Equalizers (DFE)**
- **17dB Analog Equalization at 7.1GHz with 1dB Step Control for Backplane Mode or Cable Mode**
- **Output Linear Dynamic Range: 1200mV**
- **Bandwidth: >20GHz – Typical**
- **Better than 15dB Return Loss at 7.1GHz**
- **Supports Out-of-Band (OOB) Signaling**
- **Low Power, Typically 80mW per Channel at 2.5V VCC**
- **38-Terminal QFN (Quad Flatpack, No-Lead) 5 mm x 7 mm x 0.75 mm, 0.5 mm Terminal Pitch**
- **Excellent Impedance Matching to 100Ω Differential PCB Transmission Lines**
- **GPIO or I²C Control**
- **2.5V and 3.3V±5% Single Power Supply**
- **2kV ESD (HBM)**
- **Flow-Through Pin-Out Provides Ease of Routing**
- **Small Package Size Saves Board Space**
- **Low Power**

APPLICATIONS

- **High Speed Links in Telecommunication and Data Communication**
- **Backplane and Cable Interconnects for 10GbE, 16GFC, 10G SONET, SAS, SATA, CPRI, OBSAI, Infiniband, 10GBase-KR, and XFI/SFI**

DESCRIPTION

The SN65LVCP1414 is an asynchronous, protocol-agnostic, low latency, four-channel linear equalizer optimized for use up to 14.2Gbps and compensates for losses in backplane or active cable applications. The architecture of the SN65LVCP1414 is designed to work with an ASIC or FPGA with digital equalization employing Decision Feedback Equalizers (DFE). The SN65LVCP1414 linear equalizer preserves the shape of the transmitted signal ensuring optimum DFE performance. The SN65LVCP1414 provides a low power solution while at the same time extending the effectiveness of DFE.

The SN65LVCP1414 is configurable via I²C or GPIO interface. Using the I²C interface of the SN65LVCP1414 enables the user to control independently the Equalization, Path Gain, and Output Dynamic Range for each individual channel. In GPIO mode, Equalization, Path Gain, and Output Dynamic Range can be set for all channels using the GPIO Input pins.

The SN65LVCP1414 outputs can be disabled independently via I²C.

The SN65LVCP1414 operates from a single 2.5V or 3.3V power supply.

The package for the SN65LVCP1414 is a 38 pin 5-mm x 7-mm x 0.75-mm QFN (Quad Flat-pack No-lead) lead-free package with 0.5mm pitch and is characterized for operation from –40°C to 85°C.



Please be aware that an important notice concerning availability, standard warranty, and use in critical applications of Texas Instruments semiconductor products and disclaimers thereto appears at the end of this data sheet.



This integrated circuit can be damaged by ESD. Texas Instruments recommends that all integrated circuits be handled with appropriate precautions. Failure to observe proper handling and installation procedures can cause damage.

ESD damage can range from subtle performance degradation to complete device failure. Precision integrated circuits may be more susceptible to damage because very small parametric changes could cause the device not to meet its published specifications.

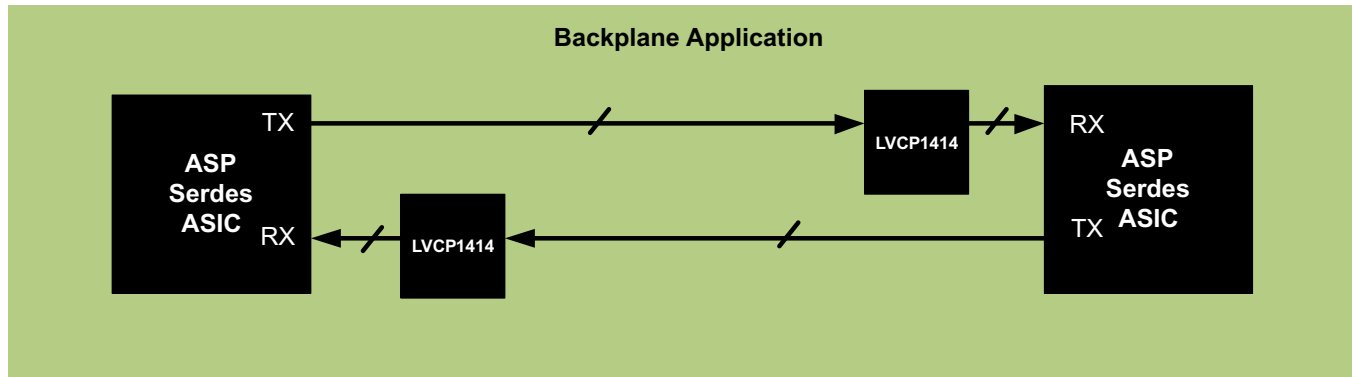

Figure 1. Typical Backplane Application – Trace Mode

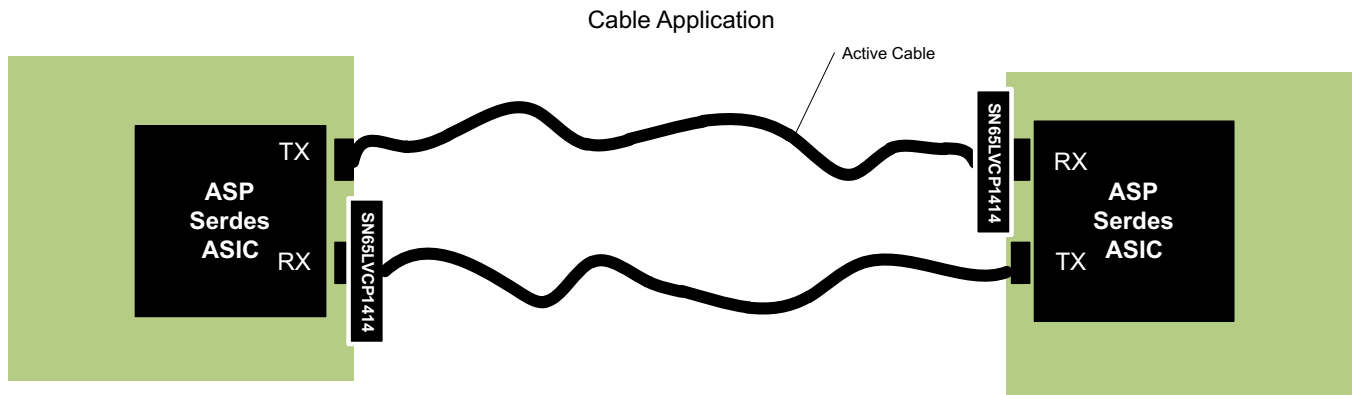

Figure 2. Typical Cable Application – Cable Mode

Block Diagram (GPIO or I²C Mode)

A simplified block diagram of the SN65LVCP1414 is shown in Figure 3 for GPIO or I²C input control mode. This compact, low power, 14.2Gbps quad-channel dual-mode linear analog equalizer consists of four high-speed data paths and an input GPIO pin logic-control block and a two-wire interface with a control-logic block.

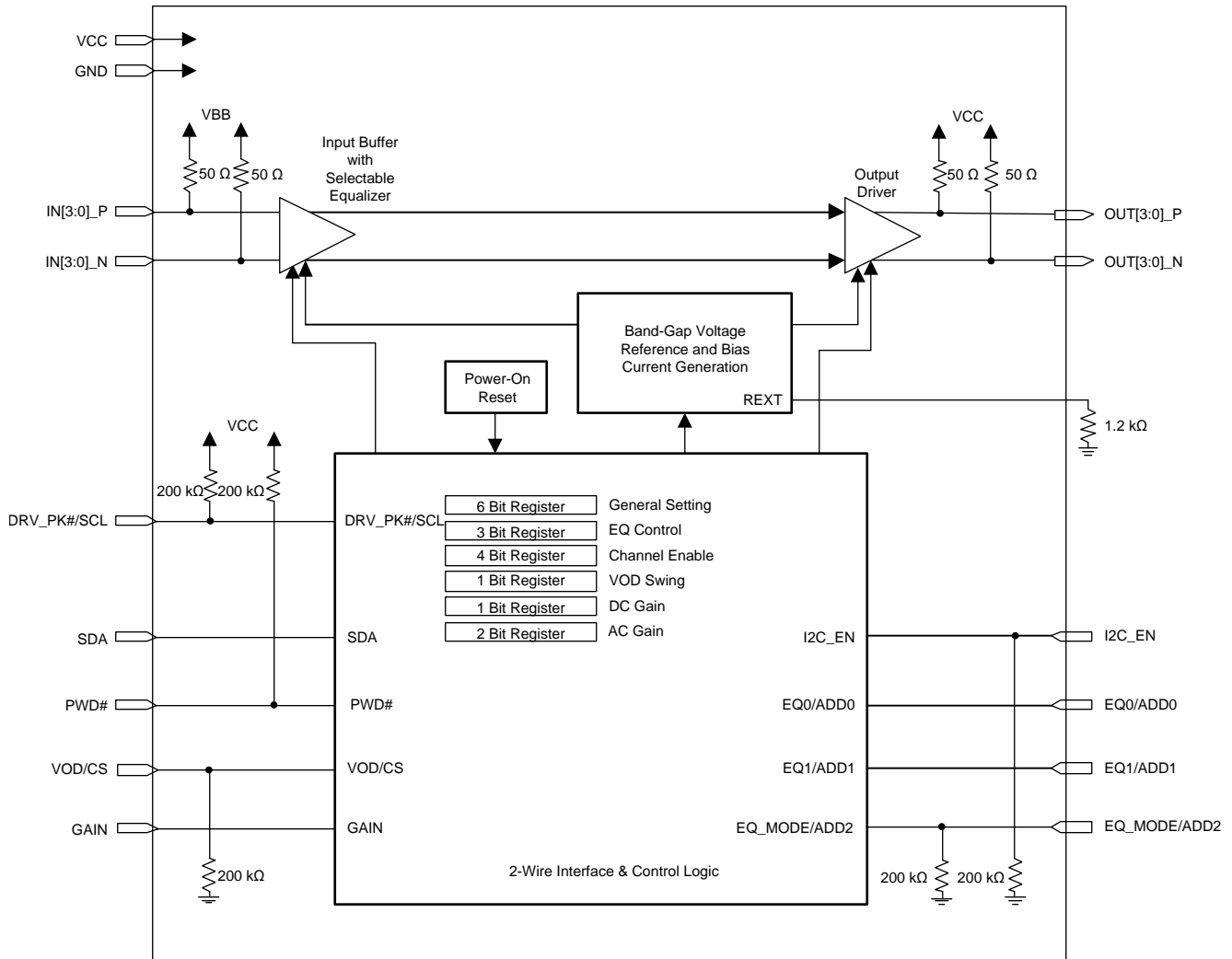

Figure 3. Simplified Block Diagram of the SN65LVCP1414

Package

The package pin locations and assignments are shown in Figure 4. The SN65LVCP1414 is packaged in a 5mm x 7mm x 0.75mm, 38 pin, 0.5mm pitch lead-free QFN.

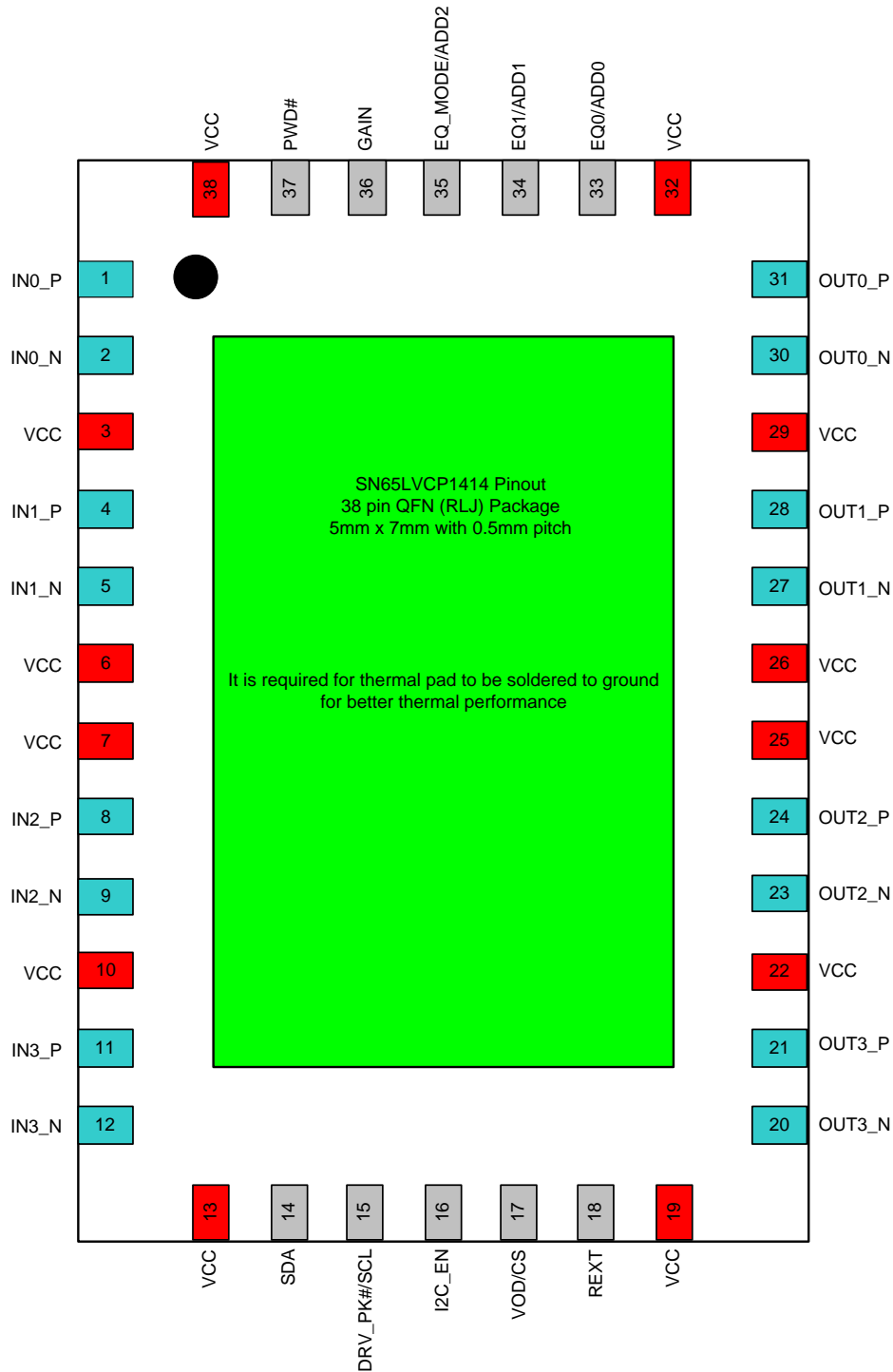

Figure 4. Package Drawing (Top View)

Pin Descriptions

PINS		DIRECTION TYPE SUPPLY	DESCRIPTION
NAME	NO.		
DIFFERENTIAL HIGH-SPEED I/O			
IN0_P IN0_N	1 2	Input, (with 50 Ω termination to input common mode)	Differential input, lane 0
IN1_P IN1_N	4 5	Input, (with 50 Ω termination to input common mode)	Differential input, lane 1
IN2_P IN2_N	8 9	Input, (with 50 Ω termination to input common mode)	Differential input, lane 2
IN3_P IN3_N	11 12	Input, (with 50 Ω termination to input common mode)	Differential input, lane 3
OUT0_P OUT0_N	31 30	Output	Differential output, lane 0
OUT1_P OUT1_N	28 27	Output	Differential output, lane 1
OUT2_P OUT2_N	24 23	Output	Differential output, lane 2
OUT3_P OUT3_N	21 20	Output	Differential output, lane 3
CONTROL SIGNALS			
SDA	14	Input Output, Open drain	GPIO mode No action needed I²C mode I ² C data. Connect a 10k Ω pull-up resistor externally
DRV_PK#/SCL	15	Input. (with 200k Ω pull-up)	GPIO mode HIGH: disable Driver peaking LOW: enables Driver 6dB AC peaking I²C mode I ² C clock. Connect a 10k Ω pull-up resistor externally
I2C_EN	16	Input, (with 200k Ω pull-down) 2.5V/3.3V CMOS	Configures the device operation for I ² C or GPIO mode: HIGH: enables I ² C mode LOW: enables GPIO mode
VOD/CS	17	Input, (with 200k Ω pull-down) 2.5V/3.3V CMOS	GPIO mode HIGH: set high VOD range LOW: set low VOD range I²C mode HIGH: acts as Chip Select LOW: disables I ² C interface
REXT	18	Input, Analog	External Bias Resistor: 1,200 Ω to GND
EQ0/ADD0	33	Input, 2.5V/3.3V CMOS - 3-state	GPIO mode Working with EQ1 to determine input EQ gain. I²C mode ADD0 along with pins ADD1 and ADD2 comprise the three bits of I ² C slave address. ADD2:ADD1:ADD0:XXX

Pin Descriptions (continued)

PINS		DIRECTION TYPE SUPPLY	DESCRIPTION																															
NAME	NO.																																	
EQ1/ADD1	34	Input, 2.5V/3.3V CMOS - 3-state	GPIO mode Working with EQ0 to determine input EQ gain steps of approximately 2dB	I²C mode ADD1 along with pins ADD0 and ADD2 comprise the three bits of I ² C slave address ADD2:ADD1:ADD0:XXX																														
			<table border="1"> <thead> <tr> <th>EQ1</th> <th>EQ0</th> <th>EQ GAIN</th> </tr> </thead> <tbody> <tr><td>GND</td><td>GND</td><td>000</td></tr> <tr><td>GND</td><td>HiZ</td><td>000</td></tr> <tr><td>GND</td><td>VCC</td><td>001</td></tr> <tr><td>HiZ</td><td>GND</td><td>010</td></tr> <tr><td>HiZ</td><td>HiZ</td><td>011</td></tr> <tr><td>HiZ</td><td>VCC</td><td>100</td></tr> <tr><td>VCC</td><td>GND</td><td>101</td></tr> <tr><td>VCC</td><td>HiZ</td><td>110</td></tr> <tr><td>VCC</td><td>VCC</td><td>111</td></tr> </tbody> </table>	EQ1	EQ0	EQ GAIN	GND	GND	000	GND	HiZ	000	GND	VCC	001	HiZ	GND	010	HiZ	HiZ	011	HiZ	VCC	100	VCC	GND	101	VCC	HiZ	110	VCC	VCC	111	
EQ1	EQ0	EQ GAIN																																
GND	GND	000																																
GND	HiZ	000																																
GND	VCC	001																																
HiZ	GND	010																																
HiZ	HiZ	011																																
HiZ	VCC	100																																
VCC	GND	101																																
VCC	HiZ	110																																
VCC	VCC	111																																
			EQ1 and EQ0 works with AC_GAIN and DC_GAIN to determine final EQ gain as this:																															
			<table border="1"> <thead> <tr> <th>EQ1/ EQ0</th> <th>GAIN</th> <th>DC GAIN (dB)</th> <th>EQ GAIN (dB)</th> </tr> </thead> <tbody> <tr><td>000 ~ 111</td><td>LOW</td><td>-6</td><td>1 ~ 9</td></tr> <tr><td>000 ~ 111</td><td>HiZ</td><td>-6</td><td>7 ~ 17</td></tr> <tr><td>000 ~ 111</td><td>HIGH</td><td>0</td><td>1 ~ 9</td></tr> </tbody> </table>	EQ1/ EQ0	GAIN	DC GAIN (dB)	EQ GAIN (dB)	000 ~ 111	LOW	-6	1 ~ 9	000 ~ 111	HiZ	-6	7 ~ 17	000 ~ 111	HIGH	0	1 ~ 9															
EQ1/ EQ0	GAIN	DC GAIN (dB)	EQ GAIN (dB)																															
000 ~ 111	LOW	-6	1 ~ 9																															
000 ~ 111	HiZ	-6	7 ~ 17																															
000 ~ 111	HIGH	0	1 ~ 9																															
EQ_MODE/ ADD2	35	Input, (with 200kΩ pull-down), 2.5V/3.3V CMOS	GPIO mode HIGH: Trace mode LOW: Cable mode	I²C mode ADD2 along with pins ADD1 and ADD0 comprise the three bits of I ² C slave address. ADD2:ADD1:ADD0:XXX																														
GAIN	36	Input, 2.5V/3.3V CMOS - 3-state	GPIO mode Work with EQ1/EQ0 to set total EQ Gain. See table above.	I²C mode No action needed																														
PWD#	37	Input, (with 200kΩ pull-up), 2.5V/3.3V CMOS	HIGH: Normal Operation LOW: Power downs the device, inputs off and outputs disabled, resets I ² C																															
POWER SUPPLY																																		
VCC	3, 6, 7, 10, 13, 19, 22, 25, 26, 29, 32, 38	Power	Power supply 2.5V±5%, 3.3V±5%																															
GND Center Pad		Ground	The ground center pad is the metal contact at the bottom of the package. This pad must be connected to the GND plane. At least 15 PCB vias are recommended to minimize inductance and provide a solid ground. Refer to the package drawing (RLJ-package) for the via placement.																															

Absolute Maximum Ratings

over operating free-air temperature range (unless otherwise noted)⁽¹⁾

		VALUES	UNIT
V _{CC}	Supply voltage range ⁽²⁾	–0.3 to 4	V
V _{IN,DIFF}	Differential voltage between INx_P and INx_N	±2.5	V
V _{IN+, IN–}	Voltage at INx_P and fINx_N	–0.5 V to VCC+0.5	V
V _{IO}	Voltage on control IO pins	–0.5 V to VCC+0.5	V
I _{IN+} I _{IN–}	Continuous current at high speed differential data inputs (differential)	–25 to 25	mA
I _{OUT+} I _{OUT–}	Continuous current at high speed differential data outputs	–25 to 25	mA
ESD	Human Body Model ⁽³⁾ (All Pins)	2.0	kV
	Charged-Device Model ⁽⁴⁾ (All Pins)	500	V
Moisture sensitivity level		3	
Reflow temperature package soldering, 4 sec		260	°C

- (1) Stresses beyond those listed under "absolute maximum ratings" may cause permanent damage to the device. These are stress ratings only and functional operation of the device at these or any other conditions beyond those indicated under "recommended operating conditions" is not implied. Exposure to absolute-maximum-rated conditions for extended periods may affect device reliability.
- (2) All voltage values, except differential I/O bus voltages, are with respect to network ground terminal.
- (3) Tested in accordance with JEDEC Standard 22, Test Method A114-A.
- (4) Tested in accordance with JEDEC Standard 22, Test Method C101.

Thermal Information

THERMAL METRIC ⁽¹⁾		SN65LVCP1414	UNITS
		RLJ (38 PINS)	
θ _{JA}	Junction-to-ambient thermal resistance ⁽²⁾	36.9	°C/W
θ _{JCtop}	Junction-to-case (top) thermal resistance ⁽³⁾	22.3	
θ _{JB}	Junction-to-board thermal resistance ⁽⁴⁾	10.7	
ψ _{JT}	Junction-to-top characterization parameter ⁽⁵⁾	0.3	
ψ _{JB}	Junction-to-board characterization parameter ⁽⁶⁾	10.6	
θ _{JCbot}	Junction-to-case (bottom) thermal resistance ⁽⁷⁾	1.9	

- (1) For more information about traditional and new thermal metrics, see the *IC Package Thermal Metrics* application report, [SPRA953](#).
- (2) The junction-to-ambient thermal resistance under natural convection is obtained in a simulation on a JEDEC-standard, high-K board, as specified in JESD51-7, in an environment described in JESD51-2a.
- (3) The junction-to-case (top) thermal resistance is obtained by simulating a cold plate test on the package top. No specific JEDEC-standard test exists, but a close description can be found in the ANSI SEMI standard G30-88.
- (4) The junction-to-board thermal resistance is obtained by simulating in an environment with a ring cold plate fixture to control the PCB temperature, as described in JESD51-8.
- (5) The junction-to-top characterization parameter, ψ_{JT}, estimates the junction temperature of a device in a real system and is extracted from the simulation data for obtaining θ_{JA}, using a procedure described in JESD51-2a (sections 6 and 7).
- (6) The junction-to-board characterization parameter, ψ_{JB}, estimates the junction temperature of a device in a real system and is extracted from the simulation data for obtaining θ_{JA}, using a procedure described in JESD51-2a (sections 6 and 7).
- (7) The junction-to-case (bottom) thermal resistance is obtained by simulating a cold plate test on the exposed (power) pad. No specific JEDEC standard test exists, but a close description can be found in the ANSI SEMI standard G30-88.

Recommended Operating Conditions

		MIN	NOM	MAX	UNIT
dR	Operating data rate			14.2	Gbps
V _{CC}	Supply voltage	2.375	2.5	2.625	V
V _{CC}	Supply voltage	3.135	3.3	3.465	V
TC	Junction temperature	-10		125	°C
TB	Maximum board temperature			85	°C
CMOS DC SPECIFICATIONS					
V _{IH}	High-level input voltage	0.8×V _{CC}			V
V _{MID}	Mid-level input voltage	V _{CC} ×0.4		V _{CC} ×0.6	V
V _{IL}	Low-level input voltage	-0.5		0.2×V _{CC}	V
PSNR BG	Bandgap circuit PSNR	20			dB

Electrical Characteristics (VCC 2.5V ±5%)

over operating free-air temperature range, all parameters are referenced to package pins (unless otherwise noted)

PARAMETER	TEST CONDITIONS	MIN	TYP ⁽¹⁾	MAX	UNIT
POWER CONSUMPTION					
PD _L	Device power dissipation VOD = LOW at 2.5V VCC with all 4 channels active		317	475	mW
PD _H	Device power dissipation VOD = HIGH, at 2.5V VCC with all 4 channels active		485	675	mW
PD _{OFF}	Device power with all 4 channels switched off Refer to I ² C section for device configuration. 2.5V VCC		10		mW

(1) All typical values are at 25°C and with 2.5V supply unless otherwise noted.

Electrical Characteristics (VCC 3.3V ±5%)

over operating free-air temperature range, all parameters are referenced to package pins (unless otherwise noted)

PARAMETER	TEST CONDITIONS	MIN	TYP ⁽¹⁾	MAX	UNIT
POWER CONSUMPTION					
PD _L	Device power dissipation VOD = LOW at 3.3V VCC with all 4 channels active		450	625	mW
PD _H	Device power dissipation VOD = HIGH, at 3.3V VCC with all 4 channels active		697	925	mW
PD _{OFF}	Device power with all 4 channels switched off Refer to I ² C section for device configuration, 3.3V VCC		10		mW

(1) All typical values are at 25°C and with 2.5V supply unless otherwise noted.

Electrical Characteristics (VCC 2.5V ±5%, 3.3V ±5%)

over operating free-air temperature range, all parameters are referenced to package pins (unless otherwise noted)

PARAMETER	TEST CONDITIONS	MIN	TYP ⁽¹⁾	MAX	UNIT
CMOS DC SPECIFICATIONS					
I _{IH}	High level input current VIN = 0.9 × V _{CC}	-40	17	40	μA
I _{IL}	Low level input current VIN = 0.1 × V _{CC}	-40	17	40	μA
CML INPUTS (IN[3:0]_P, IN[3:0]_N)					
r _{IN}	Differential input resistance INx_P to INx_N		100		Ω
V _{IN}	Input linear dynamic range Gain = 0.5		1200		mV _{pp}
V _{ICM}	Input common mode voltage Internally biased		V _{CC} -0.8		V
SCD11	Input differential to common mode conversion 100MHz to 7.1GHz		-20		dB
SDD11	Differential input return loss 100MHz to 7.1GHz		-15		dB

(1) All typical values are at 25°C and with 2.5V and 3.3V supply unless otherwise noted.

Electrical Characteristics (VCC 2.5V ±5%, 3.3V ±5%) (continued)

over operating free-air temperature range, all parameters are referenced to package pins (unless otherwise noted)

PARAMETER		TEST CONDITIONS	MIN	TYP ⁽¹⁾	MAX	UNIT
CML OUTPUTS (OUT[3:0]_P, OUT[3:0]_N)						
V _{OD}	Output linear dynamic range	R _L = 100 Ω, V _{OD} = HIGH		1200		mV _{pp}
		R _L = 100 Ω, V _{OD} = LOW		600		mV _{pp}
V _{OS}	Output offset voltage	R _L = 100 Ω, 0 V applied at inputs		10		mV _{pp}
V _{OCM}	Output common mode voltage	See Figure 5		V _{CC} -0.4		V
V _{CM,RIP}	Common mode output ripple	K28.5 pattern at 14.2Gbps on all 4 channels, No interconnect loss, VOD = HIGH		10	20	mV _{RMS}
V _{OD,RIP}	Differential path output ripple	K28.5 pattern at 14.2Gbps on all channels, No interconnect loss, VIN = 1200mVpp.			20	mV _{pp}
V _{OC(SS)}	Change in steady-state common-mode output voltage between logic states			±10		mV
t _R	Rise time ⁽²⁾	Input signal with 30ps rise time, 20% to 80%, See Figure 7		31		ps
t _F	Fall time ⁽²⁾	Input signal with 30ps fall time, 20% to 80%, See Figure 7		32		ps
SDD22	Differential output return loss	100MHz to 7.1GHz		-15		dB
SCC22	Common-mode output return loss	100MHz to 7.1GHz		-5		dB
t _{PLH}	Low-to-high propagation delay	See Figure 6		65		ps
t _{PHL}	High-to-low propagation delay			65		ps
t _{SK(O)}	Inter-Pair (lane to lane) output skew ⁽³⁾	All outputs terminated with 100 Ω, See Figure 8		8		ps
t _{SK(PP)}	Part-to-part skew ⁽⁴⁾	All outputs terminated with 100 Ω			50	ps
r _{OT}	Single ended output resistance	Single ended on-chip termination to VCC, Outputs will be AC coupled		50		Ω
r _{OM}	Output termination mismatch at 1MHz	$\Delta_{rom} = 2 \times \frac{rp - rn}{rp + rn} \times 100$		5		%
Ch _{iso}	Channel-to-channel isolation	Frequency at 7.1GHz	35	45		dB
OUT _{NOISE}	Output referred noise ⁽⁵⁾	10MHz to 7.1GHz, No other noise source present, VOD = LOW		400		μVRMS
		10MHz to 7.1GHz, No other noise source present, VOD = HIGH		500		μVRMS
EQUALIZATION						
EQ _{Gain}	At 7.1GHz input signal	Equalization Gain, EQ = MAX	15	17		dB
V _{pre}	Output pre-cursor pre-emphasis	Input signal with 3.75 pre-cursor and measure it on the output signal, Refer Figure 9 . V _{pre} = 20log(V3/V2)		3.75		dB
V _{pst}	Output post-cursor pre-emphasis	Input signal with 12dB post-cursor and measure it on the output signal, Refer Figure 9 . V _{pst} = 20log(V1/V2)		12		dB
DJ1	Residual deterministic jitter at 10.3125 Gbps	Transmit Side application Tx launch Amplitude = 0.6Vpp, EQ=0, ACGain and DCgain = Low and VOD = High, Trace Mode Test Channel -> 0", See Figure 11		0.016		Ulp-p
DJ2	Residual deterministic jitter at 10.3125 Gbps	Receive Side Application Tx launch Amplitude = 0.6Vpp, EQ=7, ACGain and VOD = High and DCgain = High, Trace Mode Test Channel -> 12" (9dB loss at 5GHz), See Figure 10		0.11		Ulp-p
DJ3	Residual deterministic jitter at 14.2 Gbps	Transmit Side Application Tx launch Amplitude = 0.6Vpp, EQ=0, ACGain and DCgain = Low and VOD = High, Trace Mode Test Channel -> 0", See Figure 11		0.041		Ulp-p
DJ4	Residual deterministic jitter at 14.2 Gbps	Receive Side Application Tx launch Amplitude = 0.6Vpp, EQ=7, ACGain and VOD = High and DCgain = High, Trace Mode Test Channel -> 8" (9dB loss at 7GHz), See Figure 10		0.13		Ulp-p

 (2) Rise and Fall measurements include board and channel effects of the test environment, refer to [Figure 10](#) and [Figure 11](#).

 (3) t_{SK(O)} is the magnitude of the time difference between the channels.

 (4) t_{SK(PP)} is the magnitude of the difference in propagation delay times between any specified terminals of two devices when both devices operate with the same supply voltages, at the same temperature, and have identical packages and test circuits.

(5) All noise sources added.

Parameter Measurement Information

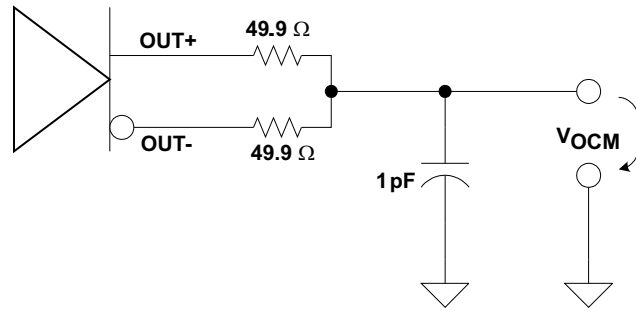

Figure 5. Common Mode Output Voltage Test Circuit

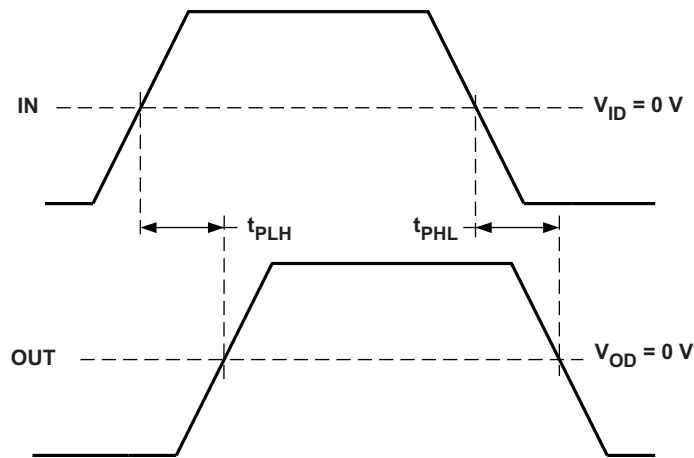

Figure 6. Propagation Delay Input to Output

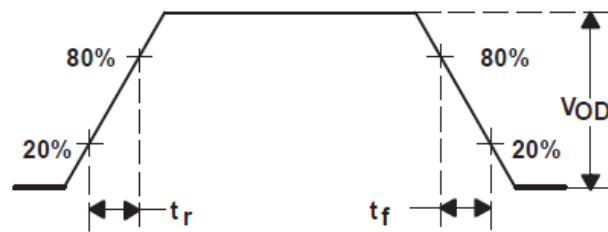

Figure 7. Output Rise and Fall Times

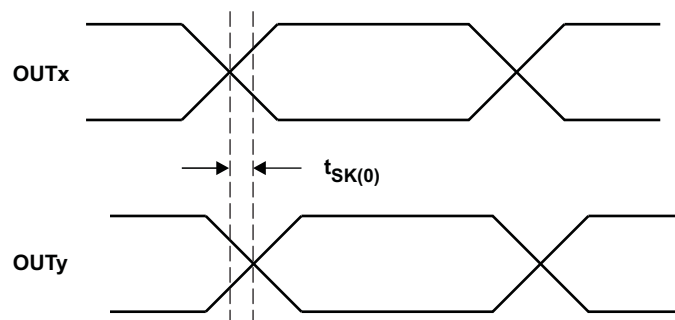

Figure 8. Output Inter-Pair Skew

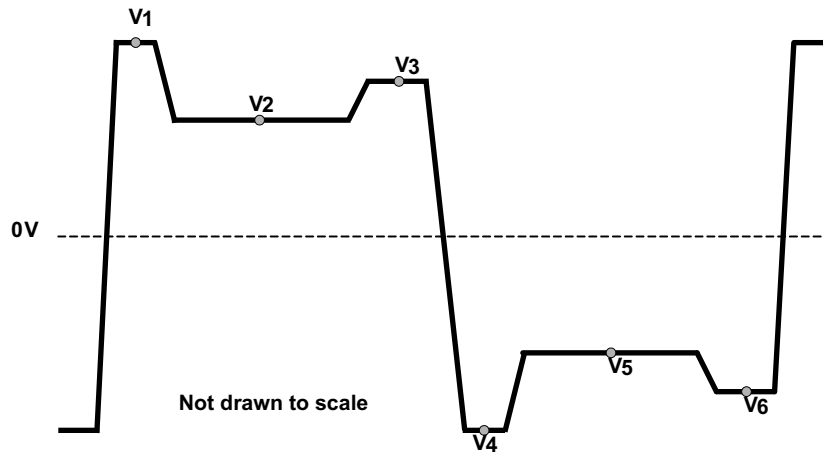

Figure 9. Vpre and Vpost (test pattern is 11111110000000 (8-1s, 8-0s))

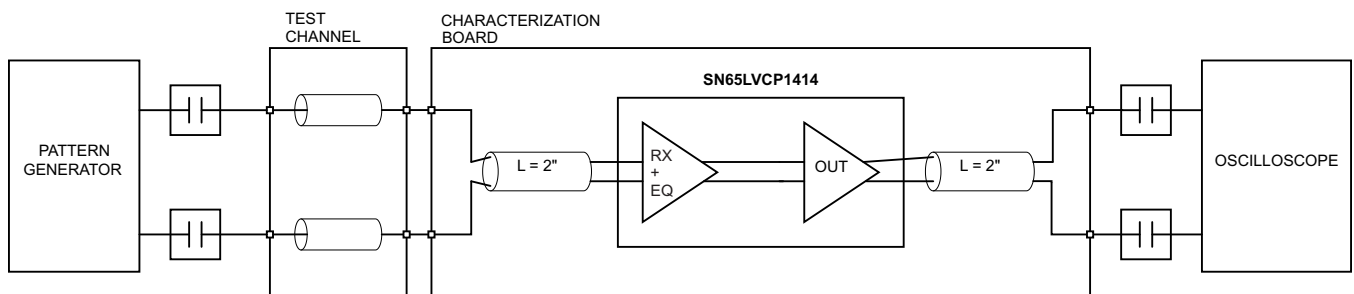

Figure 10. Receive Side Performance Test Circuit

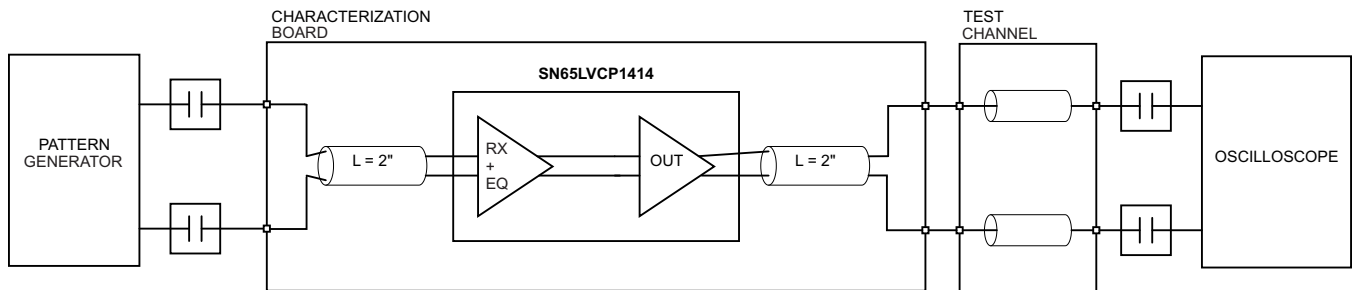

Figure 11. Transmit Side Performance Test Circuit

Equivalent Input and Output Schematic Diagrams

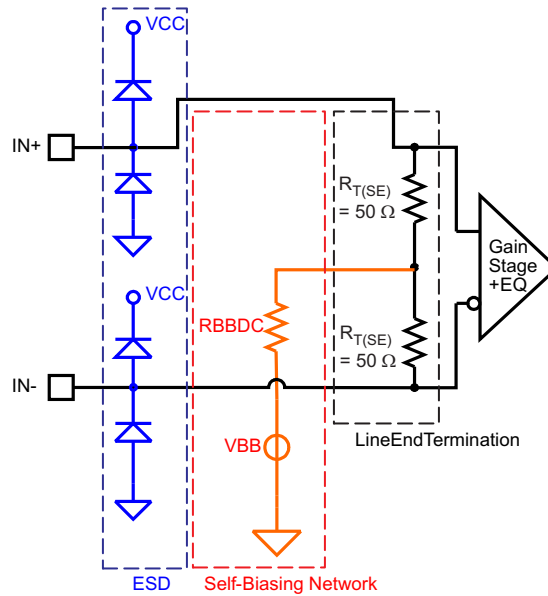

Figure 12. Equivalent Input Circuit Design

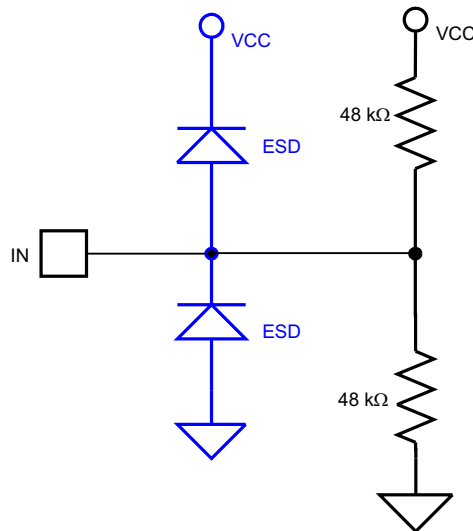

Figure 13. 3-Level Input Biasing Network

Typical Characteristics

Typical operating condition is at $V_{CC} = 2.5V$ and $T_A = 25^\circ C$, no interconnect line at the output, and with default device settings (unless otherwise noted).

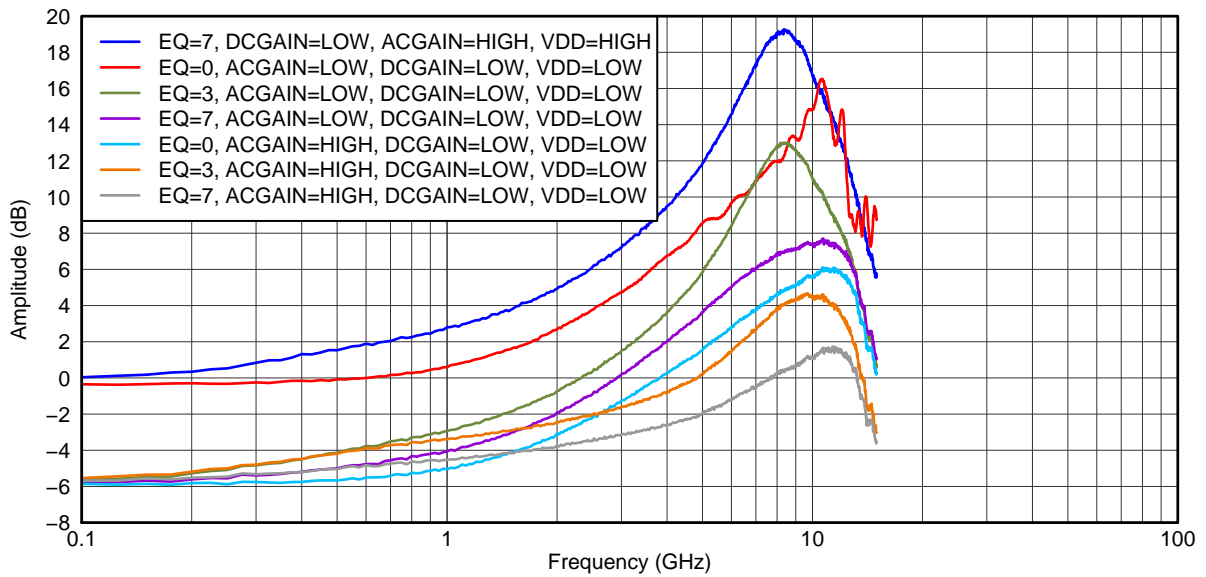

Figure 14. Typical EQ Gain Profile Curve

G001

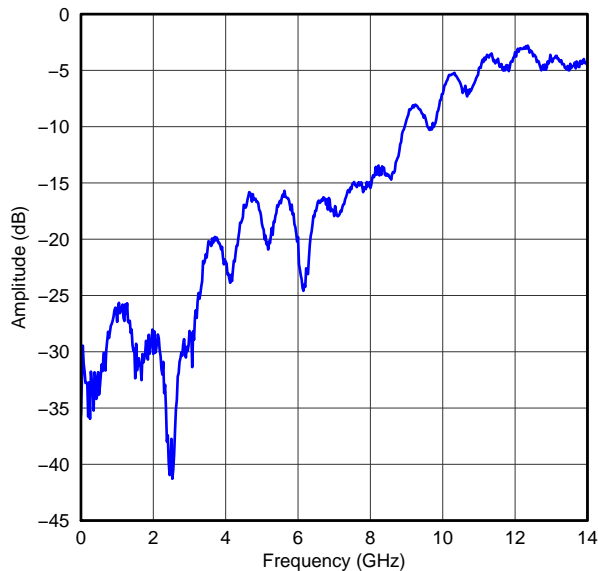

Figure 15. Differential Input Return Loss

G002

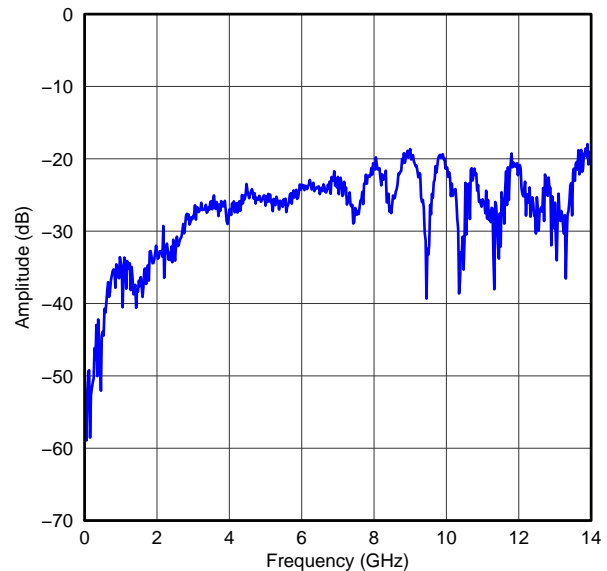

Figure 16. Differential to Common Mode Conversion

G003

Typical Characteristics (continued)

Typical operating condition is at $V_{CC} = 2.5V$ and $T_A = 25^\circ C$, no interconnect line at the output, and with default device settings (unless otherwise noted).

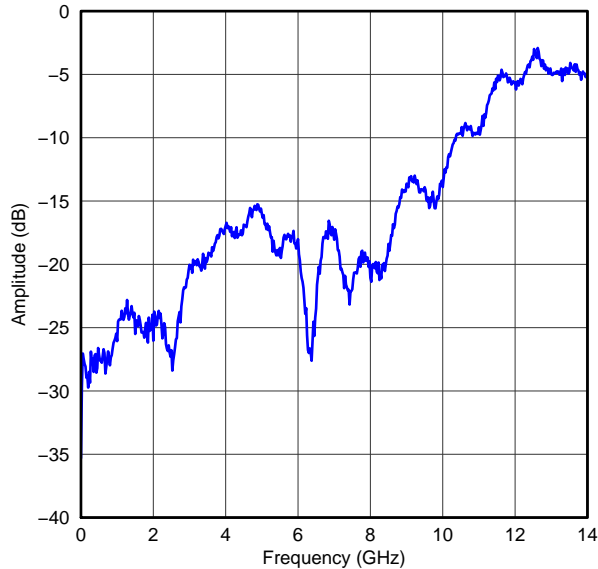

Figure 17. Differential Output Return Loss

G004

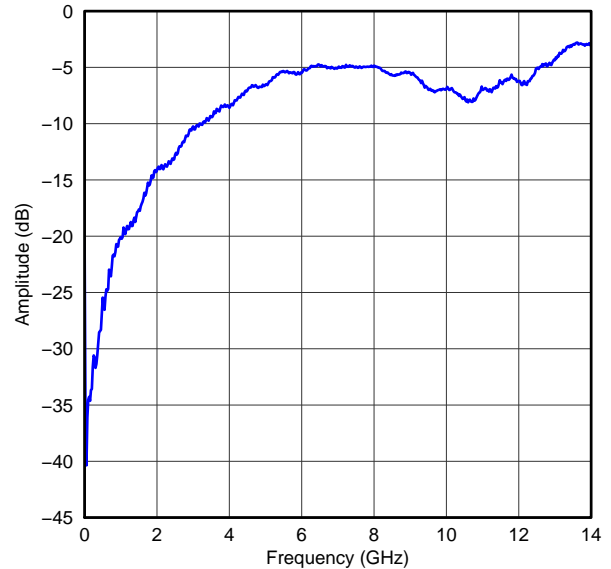

Figure 18. Common Mode Output Return Loss

G005

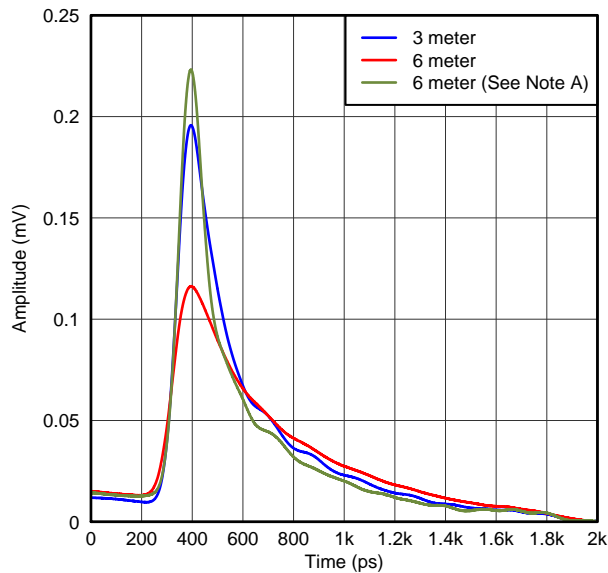

Figure 19. Cable Mode – Symbol Response

G006

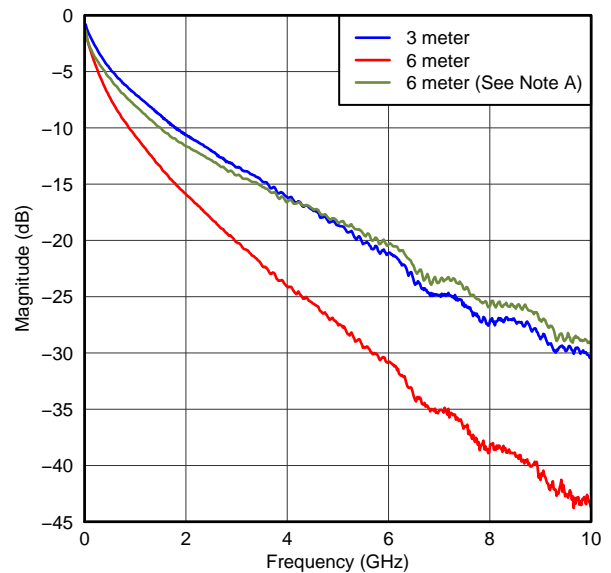

Figure 20. Cable Mode – Frequency Domain

G007

A. With SN65LVCP1414 -> EQ = 4, VOD = High, ACGain = HiZ, DCGain = Low

A. With SN65LVCP1414 -> EQ = 4, VOD = High, ACGain = HiZ, DCGain = Low

Typical Characteristics (continued)

Typical operating condition is at $V_{CC} = 2.5V$ and $T_A = 25^\circ C$, no interconnect line at the output, and with default device settings (unless otherwise noted).

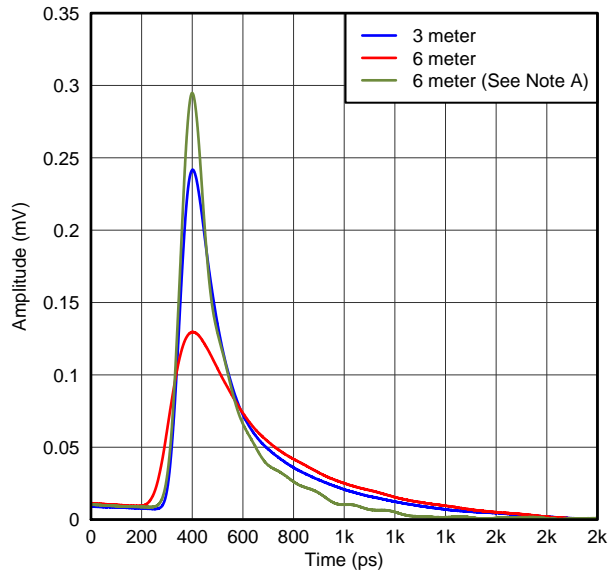

A. With SN65LVCP1414 -> EQ = 7, VOD = High, ACGain = High, DCGain = Low

Figure 21. Trace Mode – Symbol Response

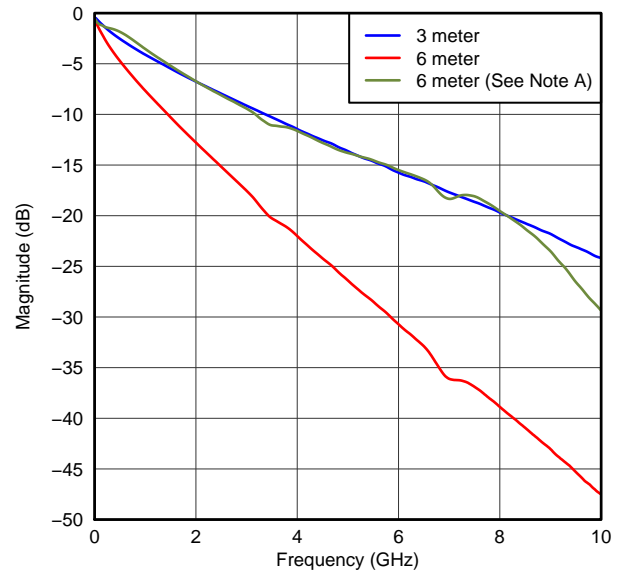

A. With SN65LVCP1414 -> EQ = 7, VOD = High, ACGain = High, DCGain = Low

Figure 22. Trace Mode - Frequency Domain

Table 1. Control Settings Descriptions

MODE	DCGAIN	ACGAIN<1:0>	EQ<2:0>	DC GAIN (dB)	EQ GAIN (dB)	APPLICATION
0	0	0	000 to 111	-6	1 to 9	Short Input Trace; Large Input Swing
0	0	11	000 to 111	-6	7 to 17	Long Input Trace; Large Input Swing
0	1	1	000 to 111	0	1 to 9	Short Input Trace; Small Input Swing
0	1	11	000 to 111	0	2 to 10	Short Input Trace; Small Input Swing
1	0	0	000 to 111	-6	1 to 9	Short Input Cable; Large Input Swing
1	0	11	000 to 111	-6	7 to 17	Long Input Cable; Large Input Swing
1	1	1	000 to 111	0	1 to 9	Short Input Cable; Small Input Swing
1	1	11	000 to 111	0	2 to 10	Short Input Cable; Small Input Swing

Table 2. Control Settings Descriptions

GAIN	DC GAIN	ACGAIN<1:0>
Low	0	00
HighZ	0	11
High	1	01

Two-Wire Serial Interface and Control Logic

The SN65LVCP1414 uses a 2-wire serial interface for digital control. The two circuit inputs, SDA and SCL, are driven, respectively, by the serial data and serial clock from a microcontroller, for example. The SDA and SCK pins require external 10kΩ pull-ups to VCC.

The 2-wire interface allows write access to the internal memory map to modify control registers and read access to read out control and status signals. The SN65LVCP1414 is a slave device only which means that it cannot initiate a transmission itself; it always relies on the availability of the SCK signal for the duration of the transmission. The master device provides the clock signal as well as the START and STOP commands. The protocol for a data transmission is as follows:

1. START command
2. 7 bit slave address (0000ADD[2:0]) followed by an eighth bit which is the data direction bit (R/W). A zero indicates a WRITE and a 1 indicates a READ. The ADD[2:0] address bits change with the status of the ADD2, ADD1, and ADD0 device pins, respectively. If the pins are left floating or pulled down, the 7 bit slave address is 0000000.
3. 8 bit register address
4. 8 bit register data word
5. STOP command

Regarding timing, the SN65LVCP1414 is I²C compatible. The typical timing is shown in [Figure 9](#) and a complete data transfer is shown in [Figure 10](#). Parameters for [Figure 9](#) are defined in [Table 3](#).

Bus Idle: Both SDA and SCL lines remain HIGH

Start Data Transfer: A change in the state of the SDA line, from HIGH to LOW, while the SCL line is HIGH, defines a START condition (S). Each data transfer is initiated with a START condition.

Stop Data Transfer: A change in the state of the SDA line from LOW to HIGH while the SCL line is HIGH defines a STOP condition (P). Each data transfer is terminated with a STOP condition; however, if the master still wishes to communicate on the bus, it can generate a repeated START condition and address another slave without first generating a STOP condition.

Data Transfer: The number of data bytes transferred between a START and a STOP condition is not limited and is determined by the master device. The receiver acknowledges the transfer of data.

Acknowledge: Each receiving device, when addressed, is obliged to generate an acknowledge bit. The transmitter releases the SDA line and a device that acknowledges must pull down the SDA line during the acknowledge clock pulse in such a way that the SDA line is stable LOW during the HIGH period of the acknowledge clock pulse. Setup and hold times must be taken into account. When a slave-receiver doesn't acknowledge the slave address, the data line must be left HIGH by the slave. The master can then generate a STOP condition to abort the transfer. If the slave-receiver does acknowledge the slave address but some time later in the transfer cannot receive any more data bytes, the master must abort the transfer. This is indicated by the slave generating the not acknowledge on the first byte to follow. The slave leaves the data line HIGH and the master generates the STOP condition.

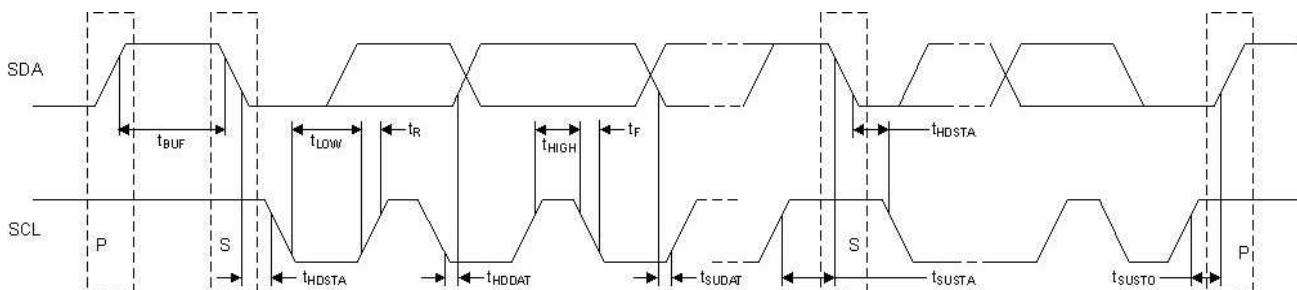

Figure 23. Two-Wire Serial Interface Timing Diagram

Table 3. Two-Wire Serial Interface Timing Diagram Definitions

SYMBOL	PARAMETER	MIN	MAX	UNIT
f_{SCL}	SCL clock frequency		400	kHz
t_{BUF}	Bus free time between START and STOP conditions	1.3		μ s
t_{HDSTA}	Hold time after repeated START condition. After this period, the first clock pulse is generated	0.6		μ s
t_{LOW}	Low period of the SCL clock	1.3		μ s
t_{HIGH}	High period of the SCL clock	0.6		μ s
t_{SUSTA}	Setup time for a repeated START condition	0.6		μ s
t_{HDDAT}	Data HOLD time	0		μ s
t_{SUDAT}	Data setup time	100		ns
t_R	Rise time of both SDA and SCL signals		300	ns
t_F	Fall time of both SDA and SCL signals		300	ns
t_{SUSTO}	Setup time for STOP condition	0.6		μ s

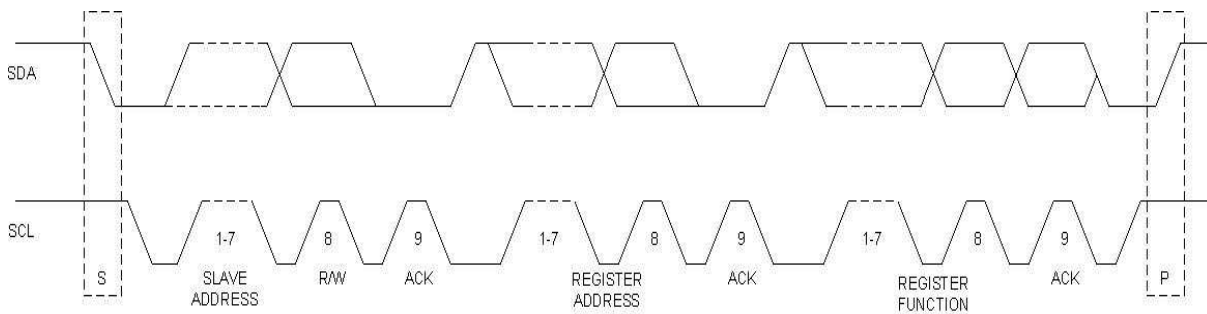

Figure 24. Two-Wire Serial Interface Data Transfer

Register Mapping

The register mapping for read/write register addresses 0 (0x00) through 22 (0x18) are shown in [Table 4](#). [Table 5](#) describes the circuit functionality based on the register settings.

Table 4. SN65LVCP1414 Register Mapping Information

Register 0x00 (General Device Settings) R/W							
bit 7	bit 6	bit 5	bit 4	bit 3	bit 2	bit 1	bit 0
SW_GPIO	PWRDOWN	SYNC_01	SYNC_23	SYNC_ALL	EQ_MODE		RSVD
Register 0x01 (Channel Enable) R/W							
bit 7	bit 6	bit 5	bit 4	bit 3	bit 2	bit 1	bit 0
				LN_EN_CH3	LN_EN_CH2	LN_EN_CH1	LN_EN_CH0
Register 0x02 (Channel 0 Control Settings) R/W							
bit 7	bit 6	bit 5	bit 4	bit 3	bit 2	bit 1	bit 0
RSVD	EQ2	EQ1	EQ0	VOD_CTRL	DC_GAIN	AC_GAIN1	AC_GAIN0
Register 0x03 (Channel 0 Enable Settings) R/W							
bit 7	bit 6	bit 5	bit 4	bit 3	bit 2	bit 1	bit 0
					DRV_PEAK	EQ_EN	DRV_EN
Register 0x05 (Channel 1 Control Settings) R/W							
bit 7	bit 6	bit 5	bit 4	bit 3	bit 2	bit 1	bit 0
RSVD	EQ2	EQ1	EQ0	VOD_CTRL	DC_GAIN	AC_GAIN1	AC_GAIN0
Register 0x06 (Channel 1 Enable Settings) R/W							
bit 7	bit 6	bit 5	bit 4	bit 3	bit 2	bit 1	bit 0
					DRV_PEAK	EQ_EN	DRV_EN
Register 0x08 (Channel 2 Control Settings) R/W							
bit 7	bit 6	bit 5	bit 4	bit 3	bit 2	bit 1	bit 0
RSVD	EQ2	EQ1	EQ0	VOD_CTRL	DC_GAIN	AC_GAIN1	AC_GAIN0
Register 0x09 (Channel 2 Enable Settings) R/W							
bit 7	bit 6	bit 5	bit 4	bit 3	bit 2	bit 1	bit 0
					DRV_PEAK	EQ_EN	DRV_EN
Register 0x0B (Channel 3 Control Settings) R/W							
bit 7	bit 6	bit 5	bit 4	bit 3	bit 2	bit 1	bit 0
RSVD	EQ2	EQ1	EQ0	VOD_CTRL	DC_GAIN	AC_GAIN1	AC_GAIN0
Register 0x0C (Channel 3 Enable Settings) R/W							
bit 7	bit 6	bit 5	bit 4	bit 3	bit 2	bit 1	bit 0
					DRV_PEAK	EQ_EN	DRV_EN
Register 0x0F Read Only							
bit 7	bit 6	bit 5	bit 4	bit 3	bit 2	bit 1	bit 0
RSVD	RSVD	RSVD	RSVD	RSVD	RSVD	RSVD	RSVD
Register 0x11 R/W							
bit 7	bit 6	bit 5	bit 4	bit 3	bit 2	bit 1	bit 0
	RSVD						
Register 0x12 R/W							
bit 7	bit 6	bit 5	bit 4	bit 3	bit 2	bit 1	bit 0
RSVD							

Table 5. SN65LVCP1414 Register Description

REGISTER	BIT	SYMBOL	FUNCTION	DEFAULT
0x00	7	SW_GPIO	Switching logic is controlled by GPIO or I ² C: 0 = I ² C control 1 = GPIO control	00000000
	6	PWRDOWN	Power down the device: 0 = Normal operation 1 = Powerdown	
	5	SYNC_01	All settings from channel 1 will be used for channel 0 and 1: 0 = Channel 0 tracking channel 1 settings 1 = No tracking tracking	
	4	SYNC_23	All settings from channel 2 will be used for channel 2 and 3: 0 = Channel 3 tracking channel 2 settings 1 = No channel tracking	
	3	SYNC_ALL	All settings from channel 1 will be used on all channels: 0 = All channels tracking channel 1 1 = No channel tracking Overwrites SYNC_01 and SYNC_23	
	2	EQ_MD	Set EQ mode: 0 = Cable mode 1 = Trace mode	
	1			
	0	RSVD	For TI use only	
0x01	7			00000000
	6			
	5			
	4			
	3	LN_EN_CH3	Channel 3 enable: 0 = Enable 1 = Disable	
	2	LN_EN_CH2	Channel 2 enable: 0 = Enable 1 = Disable	
	1	LN_EN_CH1	Channel 1 enable: 0 = Enable 1 = Disable	
	0	LN_EN_CH0	Channel 0 enable: 0 = Enable 1 = Disable	
0x02 0x05 0x08 0x0B	7	RSVD		00000000
	6	EQ2	Equalizer adjustment setting: 000 = Minimum equalization setting 111 = Maximum equalization setting	
	5	EQ1		
	4	EQ0		
	3	VOD_CTRL	Channel [x] VOD control: 0 = Low VOD range 1 = High VOD range	
	2	DC_GAIN_CTRL	Channel [x] EQ DC gain: 0 = Set EQ DC gain to 0.5x 1 = Set EQ DC gain to 1x	
	1	AC_GAIN_CTRL1	AC Gain Control: 00 = Low 01 = HiZ 11 = High	
	0	AC_GAIN_CTRL0		

Table 5. SN65LVCP1414 Register Description (continued)

REGISTER	BIT	SYMBOL	FUNCTION	DEFAULT
0x03 0x06 0x09 0x0C	7			00000000
	6			
	5			
	4			
	3			
	2	DRV_PEAK	Channel [x] driver peaking: 0 = Disables driver Peaking 1 = Enables driver 6db AC Peaking	
	1	EQ_EN	Channel [x] EQ stage enable: 0 = Enable 1 = Disable	
	0	DRV_EN	Channel [x] driver stage enable: 0 = Enable 1 = Disable	
0x0F	7	RSVD	For TI use only	00110000
	6	RSVD	For TI use only	
	5	RSVD	For TI use only	
	4	RSVD	For TI use only	
	3	RSVD	For TI use only	
	2	RSVD	For TI use only	
	1	RSVD	For TI use only	
	0	RSVD	For TI use only	
0x11	7			00000000
	6	RSVD	For TI use only	
	5			
	4			
	3			
	2			
	1			
	0			
0x12	7	RSVD	For TI use only	00000000
	6			
	5			
	4			
	3			
	2			
	1			
	0			

REVISION HISTORY

Changes from Original (August 2012) to Revision A	Page
• Changed OUT2_P pin number from 23 to 24	5
• Changed OUT2_N pin number from 24 to 23	5
• Changed OUT3_P pin number from 20 to 21	5
• Changed OUT3_N pin number from 21 to 20	5

PACKAGING INFORMATION

Orderable Device	Status (1)	Package Type	Package Drawing	Pins	Package Qty	Eco Plan (2)	Lead/Ball Finish	MSL Peak Temp (3)	Op Temp (°C)	Top-Side Markings (4)	Samples
SN65LVCP1414RLJR	ACTIVE	WQFN	RLJ	38	3000	Green (RoHS & no Sb/Br)	CU NIPDAU	Level-3-260C-168 HR	-40 to 85	LVCP 1414	Samples
SN65LVCP1414RLJT	ACTIVE	WQFN	RLJ	38	250	Green (RoHS & no Sb/Br)	CU NIPDAU	Level-3-260C-168 HR	-40 to 85	LVCP 1414	Samples

(1) The marketing status values are defined as follows:

ACTIVE: Product device recommended for new designs.

LIFEBUY: TI has announced that the device will be discontinued, and a lifetime-buy period is in effect.

NRND: Not recommended for new designs. Device is in production to support existing customers, but TI does not recommend using this part in a new design.

PREVIEW: Device has been announced but is not in production. Samples may or may not be available.

OBSOLETE: TI has discontinued the production of the device.

(2) Eco Plan - The planned eco-friendly classification: Pb-Free (RoHS), Pb-Free (RoHS Exempt), or Green (RoHS & no Sb/Br) - please check <http://www.ti.com/productcontent> for the latest availability information and additional product content details.

TBD: The Pb-Free/Green conversion plan has not been defined.

Pb-Free (RoHS): TI's terms "Lead-Free" or "Pb-Free" mean semiconductor products that are compatible with the current RoHS requirements for all 6 substances, including the requirement that lead not exceed 0.1% by weight in homogeneous materials. Where designed to be soldered at high temperatures, TI Pb-Free products are suitable for use in specified lead-free processes.

Pb-Free (RoHS Exempt): This component has a RoHS exemption for either 1) lead-based flip-chip solder bumps used between the die and package, or 2) lead-based die adhesive used between the die and leadframe. The component is otherwise considered Pb-Free (RoHS compatible) as defined above.

Green (RoHS & no Sb/Br): TI defines "Green" to mean Pb-Free (RoHS compatible), and free of Bromine (Br) and Antimony (Sb) based flame retardants (Br or Sb do not exceed 0.1% by weight in homogeneous material)

(3) MSL, Peak Temp. -- The Moisture Sensitivity Level rating according to the JEDEC industry standard classifications, and peak solder temperature.

(4) Multiple Top-Side Markings will be inside parentheses. Only one Top-Side Marking contained in parentheses and separated by a "~" will appear on a device. If a line is indented then it is a continuation of the previous line and the two combined represent the entire Top-Side Marking for that device.

Important Information and Disclaimer: The information provided on this page represents TI's knowledge and belief as of the date that it is provided. TI bases its knowledge and belief on information provided by third parties, and makes no representation or warranty as to the accuracy of such information. Efforts are underway to better integrate information from third parties. TI has taken and continues to take reasonable steps to provide representative and accurate information but may not have conducted destructive testing or chemical analysis on incoming materials and chemicals. TI and TI suppliers consider certain information to be proprietary, and thus CAS numbers and other limited information may not be available for release.

In no event shall TI's liability arising out of such information exceed the total purchase price of the TI part(s) at issue in this document sold by TI to Customer on an annual basis.

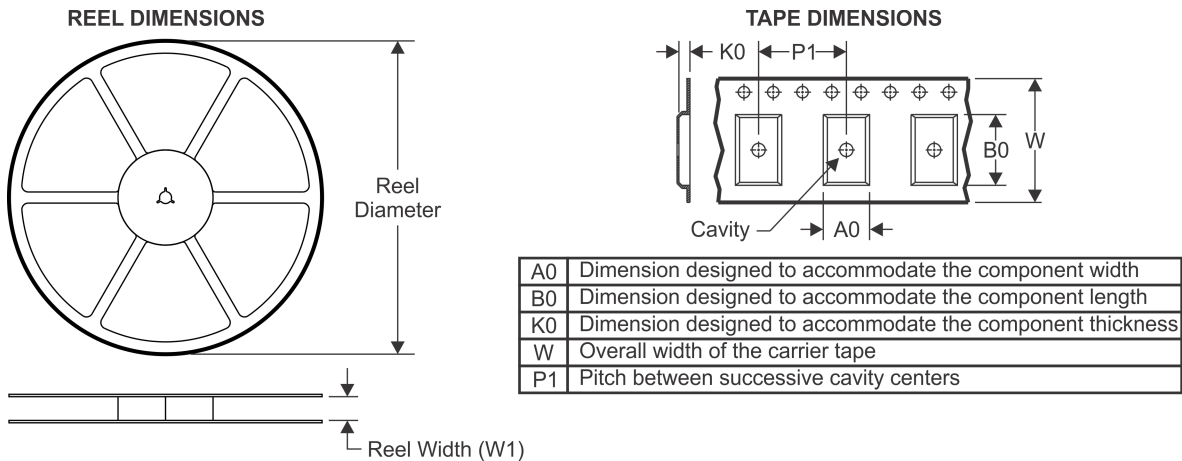
TAPE AND REEL INFORMATION

QUADRANT ASSIGNMENTS FOR PIN 1 ORIENTATION IN TAPE

*All dimensions are nominal

Device	Package Type	Package Drawing	Pins	SPQ	Reel Diameter (mm)	Reel Width W1 (mm)	A0 (mm)	B0 (mm)	K0 (mm)	P1 (mm)	W (mm)	Pin1 Quadrant
SN65LVCP1414RLJR	WQFN	RLJ	38	3000	330.0	16.4	5.25	7.25	1.45	8.0	16.0	Q1
SN65LVCP1414RLJT	WQFN	RLJ	38	250	330.0	16.4	5.25	7.25	1.45	8.0	16.0	Q1

TAPE AND REEL BOX DIMENSIONS

*All dimensions are nominal

Device	Package Type	Package Drawing	Pins	SPQ	Length (mm)	Width (mm)	Height (mm)
SN65LVCP1414RLJR	WQFN	RLJ	38	3000	367.0	367.0	38.0
SN65LVCP1414RLJT	WQFN	RLJ	38	250	367.0	367.0	38.0

RLJ (R-PWQFN-N38)

PLASTIC QUAD FLATPACK NO-LEAD

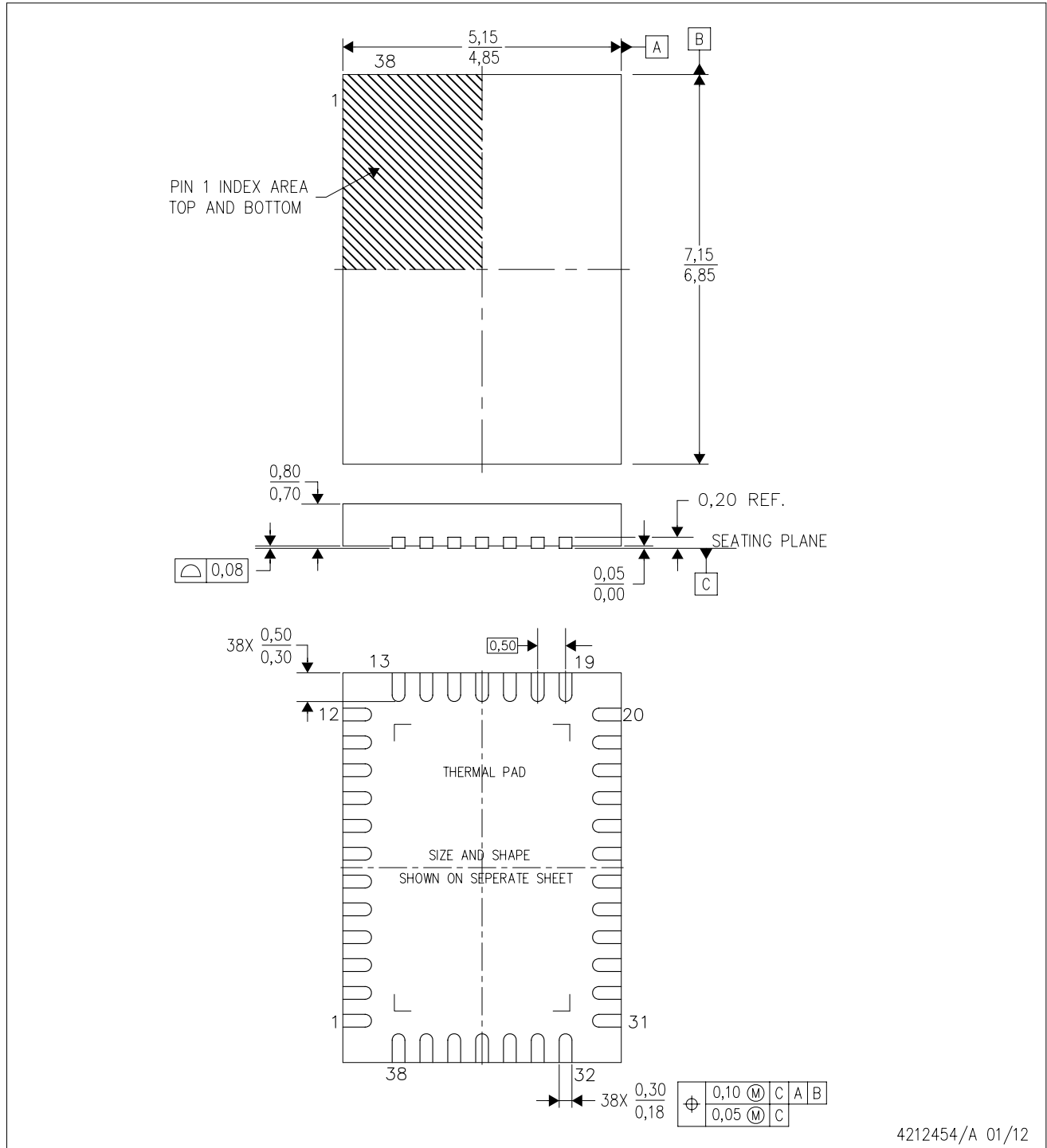

4212454/A 01/12

- NOTES:
- All linear dimensions are in millimeters. Dimensioning and tolerancing per ASME Y14.5-1994.
 - This drawing is subject to change without notice.
 - Quad Flatpack, No-leads (QFN) package configuration.
 - The package thermal pad must be soldered to the board for thermal and mechanical performance.
 - See the additional figure in the Product Data Sheet for details regarding the exposed thermal pad features and dimensions.
 - Falls within JEDEC MO-220.

IMPORTANT NOTICE

Texas Instruments Incorporated and its subsidiaries (TI) reserve the right to make corrections, enhancements, improvements and other changes to its semiconductor products and services per JESD46, latest issue, and to discontinue any product or service per JESD48, latest issue. Buyers should obtain the latest relevant information before placing orders and should verify that such information is current and complete. All semiconductor products (also referred to herein as "components") are sold subject to TI's terms and conditions of sale supplied at the time of order acknowledgment.

TI warrants performance of its components to the specifications applicable at the time of sale, in accordance with the warranty in TI's terms and conditions of sale of semiconductor products. Testing and other quality control techniques are used to the extent TI deems necessary to support this warranty. Except where mandated by applicable law, testing of all parameters of each component is not necessarily performed.

TI assumes no liability for applications assistance or the design of Buyers' products. Buyers are responsible for their products and applications using TI components. To minimize the risks associated with Buyers' products and applications, Buyers should provide adequate design and operating safeguards.

TI does not warrant or represent that any license, either express or implied, is granted under any patent right, copyright, mask work right, or other intellectual property right relating to any combination, machine, or process in which TI components or services are used. Information published by TI regarding third-party products or services does not constitute a license to use such products or services or a warranty or endorsement thereof. Use of such information may require a license from a third party under the patents or other intellectual property of the third party, or a license from TI under the patents or other intellectual property of TI.

Reproduction of significant portions of TI information in TI data books or data sheets is permissible only if reproduction is without alteration and is accompanied by all associated warranties, conditions, limitations, and notices. TI is not responsible or liable for such altered documentation. Information of third parties may be subject to additional restrictions.

Resale of TI components or services with statements different from or beyond the parameters stated by TI for that component or service voids all express and any implied warranties for the associated TI component or service and is an unfair and deceptive business practice. TI is not responsible or liable for any such statements.

Buyer acknowledges and agrees that it is solely responsible for compliance with all legal, regulatory and safety-related requirements concerning its products, and any use of TI components in its applications, notwithstanding any applications-related information or support that may be provided by TI. Buyer represents and agrees that it has all the necessary expertise to create and implement safeguards which anticipate dangerous consequences of failures, monitor failures and their consequences, lessen the likelihood of failures that might cause harm and take appropriate remedial actions. Buyer will fully indemnify TI and its representatives against any damages arising out of the use of any TI components in safety-critical applications.

In some cases, TI components may be promoted specifically to facilitate safety-related applications. With such components, TI's goal is to help enable customers to design and create their own end-product solutions that meet applicable functional safety standards and requirements. Nonetheless, such components are subject to these terms.

No TI components are authorized for use in FDA Class III (or similar life-critical medical equipment) unless authorized officers of the parties have executed a special agreement specifically governing such use.

Only those TI components which TI has specifically designated as military grade or "enhanced plastic" are designed and intended for use in military/aerospace applications or environments. Buyer acknowledges and agrees that any military or aerospace use of TI components which have **not** been so designated is solely at the Buyer's risk, and that Buyer is solely responsible for compliance with all legal and regulatory requirements in connection with such use.

TI has specifically designated certain components as meeting ISO/TS16949 requirements, mainly for automotive use. In any case of use of non-designated products, TI will not be responsible for any failure to meet ISO/TS16949.

Products

Audio	www.ti.com/audio
Amplifiers	amplifier.ti.com
Data Converters	dataconverter.ti.com
DLP® Products	www.dlp.com
DSP	dsp.ti.com
Clocks and Timers	www.ti.com/clocks
Interface	interface.ti.com
Logic	logic.ti.com
Power Mgmt	power.ti.com
Microcontrollers	microcontroller.ti.com
RFID	www.ti-rfid.com
OMAP Applications Processors	www.ti.com/omap
Wireless Connectivity	www.ti.com/wirelessconnectivity

Applications

Automotive and Transportation	www.ti.com/automotive
Communications and Telecom	www.ti.com/communications
Computers and Peripherals	www.ti.com/computers
Consumer Electronics	www.ti.com/consumer-apps
Energy and Lighting	www.ti.com/energy
Industrial	www.ti.com/industrial
Medical	www.ti.com/medical
Security	www.ti.com/security
Space, Avionics and Defense	www.ti.com/space-avionics-defense
Video and Imaging	www.ti.com/video

TI E2E Community

e2e.ti.com

Looking for pricing, stock, or lifecycle information?

Click below to explore more details on WIN SOURCE:

 [View SN65LVCP1414RLJT on WIN SOURCE](#)

 [Texas Instruments](#) Information

Optimize Your Supply Chain with WIN SOURCE Solutions

-  Global Sourcing Solution
-  Obsolete Management
-  Cost Control Management
-  Shortage Management
-  Alternative Solution
-  Excess Inventory Management