



**THE DATASHEET OF
SN74AVC8T245QPWRQ1**



SN74AVC8T245-Q1 8-Bit Dual-Supply Bus Transceiver With Configurable Voltage Translation and 3-State Outputs

1 Features

- Qualified for Automotive Applications
- AEC Q100 Test Guidance With the Following Results:
 - Device Temperature Grade 1: -40°C to $+125^{\circ}\text{C}$ Ambient Operating Temperature Range
 - Device HBM ESD Classification Level H2
 - Device CDM ESD Classification Level C3B
- Control Inputs V_{IH} and V_{IL} Levels Are Referenced to V_{CCA} Voltage
- V_{CC} Isolation Feature – If Either V_{CC} Input Is at GND, All I/O Ports Are in the High-Impedance State
- I_{off} Supports Partial Power-Down-Mode Operation
- Fully Configurable Dual-Rail Design Allows Each Port to Operate Over the Full 1.4-V to 3.6-V Power-Supply Range
- I/Os Are 4.6-V Tolerant
- Maximum Data Rates
 - 170 Mbps ($V_{CCA} < 1.8\text{ V}$ or $V_{CCB} < 1.8\text{ V}$)
 - 320 Mbps ($V_{CCA} \geq 1.8\text{ V}$ and $V_{CCB} \geq 1.8\text{ V}$)
- Latch-Up Performance Exceeds 100 mA per JESD 78, Class II

2 Applications

- Telematics
- Cluster
- Head Unit
- Navigation Systems

3 Description

The SN74AVC8T245-Q1 is an 8-bit noninverting bus transceiver that uses two separate configurable power-supply rails. The SN74AVC8T245-Q1 operation is optimal with V_{CCA} and V_{CCB} set at 1.4 V to 3.6 V. It is operational with V_{CCA} and V_{CCB} as low as 1.2 V. The A port is designed to track V_{CCA} . V_{CCA} accepts any supply voltage from 1.2 V to 3.6 V. The B port is designed to track V_{CCB} . V_{CCB} accepts any supply voltage from 1.2 V to 3.6 V. This allows for universal low-voltage bidirectional translation between any of the 1.2-V, 1.5-V, 1.8-V, 2.5-V, and 3.3-V voltage nodes.

The SN74AVC8T245 design enables asynchronous communication between data buses. The device transmits data from the A bus to the B bus or from the B bus to the A bus, depending on the logic level at the direction-control (DIR) input. One can use the output-enable (\overline{OE}) input to disable the outputs so the buses are effectively isolated.

In the SN74AVC8T245 design, V_{CCA} supplies the control pins (DIR and \overline{OE}).

Device Information⁽¹⁾

| PART NUMBER | PACKAGE | BODY SIZE (NOM) |
|-----------------|------------|-------------------|
| SN74AVC8T245-Q1 | VQFN (24) | 3.50 mm x 3.50 mm |
| | TSSOP (24) | 5.00 mm x 4.40 mm |

(1) For all available packages, see the orderable addendum at the end of the data sheet.

Logic Diagram (Positive Logic)

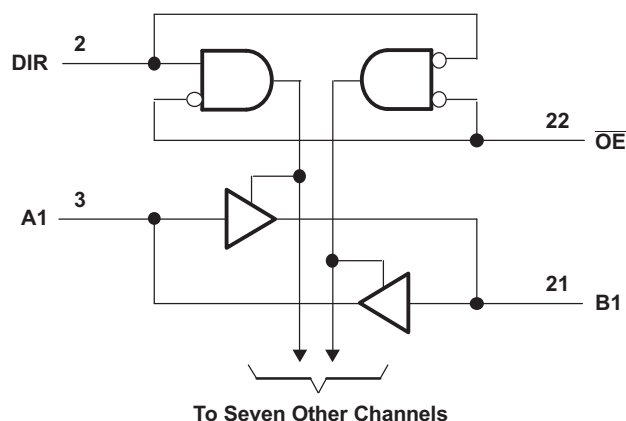

Table of Contents

| | | | | | |
|----------|---|-----------|-----------|---|-----------|
| 1 | Features | 1 | 9 | Detailed Description | 16 |
| 2 | Applications | 1 | 9.1 | Overview | 16 |
| 3 | Description | 1 | 9.2 | Functional Block Diagram | 16 |
| 4 | Revision History | 2 | 9.3 | Feature Description | 16 |
| 5 | Description (continued) | 3 | 9.4 | Device Functional Modes | 16 |
| 6 | Pin Configuration and Functions | 3 | 10 | Application and Implementation | 17 |
| 7 | Specifications | 4 | 10.1 | Application Information | 17 |
| 7.1 | Absolute Maximum Ratings | 4 | 10.2 | Typical Application | 17 |
| 7.2 | ESD Ratings | 4 | 11 | Power Supply Recommendations | 19 |
| 7.3 | Recommended Operating Conditions | 5 | 12 | Layout | 19 |
| 7.4 | Thermal Information | 6 | 12.1 | Layout Guidelines | 19 |
| 7.5 | Electrical Characteristics | 6 | 12.2 | Layout Example | 20 |
| 7.6 | Switching Characteristics: $V_{CCA} = 1.2\text{ V}$ | 7 | 13 | Device and Documentation Support | 21 |
| 7.7 | Switching Characteristics: $V_{CCA} = 1.5\text{ V} \pm 0.1\text{ V}$ | 8 | 13.1 | Documentation Support | 21 |
| 7.8 | Switching Characteristics: $V_{CCA} = 1.8\text{ V} \pm 0.15\text{ V}$ | 9 | 13.2 | Receiving Notification of Documentation Updates | 21 |
| 7.9 | Switching Characteristics: $V_{CCA} = 2.5\text{ V} \pm 0.2\text{ V}$ | 9 | 13.3 | Community Resources | 21 |
| 7.10 | Switching Characteristics: $V_{CCA} = 3.3\text{ V} \pm 0.3\text{ V}$ | 10 | 13.4 | Trademarks | 21 |
| 7.11 | Operating Characteristics | 11 | 13.5 | Electrostatic Discharge Caution | 21 |
| 7.12 | Typical Characteristics | 13 | 13.6 | Glossary | 21 |
| 8 | Parameter Measurement Information | 15 | 14 | Mechanical, Packaging, and Orderable Information | 21 |

4 Revision History

NOTE: Page numbers for previous revisions may differ from page numbers in the current version.

| Changes from Revision C (March 2016) to Revision D | Page |
|---|------|
| • Added Junction temperature, T_J in <i>Absolute Maximum Ratings</i> table | 4 |
| • Deleted 2DIR and 2OE from <i>Overview</i> | 16 |
| • Added <i>Documentation Support</i> and <i>Receiving Notification of Documentation Updates</i> | 21 |

| Changes from Revision B (December 2012) to Revision C | Page |
|--|------|
| • Added <i>ESD Ratings</i> table, <i>Feature Description</i> section, <i>Device Functional Modes</i> , <i>Application and Implementation</i> section, <i>Power Supply Recommendations</i> section, <i>Layout</i> section, <i>Device and Documentation Support</i> section, and <i>Mechanical, Packaging, and Orderable Information</i> section. | 1 |
| • Deleted <i>Ordering Information</i> table | 1 |

| Changes from Revision A (June 2011) to Revision B | Page |
|---|------|
| • Added bullets to the Features list | 1 |
| • Added <i>Pin Functions</i> table to the data sheet | 3 |
| • Deleted θ_{JA} row from <i>Absolute Maximum Ratings</i> table | 4 |
| • Changed ESD ratings | 4 |
| • Added Thermal Information table | 6 |
| • Added Figure 10 and Figure 11 to the <i>Typical Characteristics</i> section | 13 |

5 Description (continued)

This device specification covers partial-power-down applications using I_{off} . The I_{off} circuitry disables the outputs when the device is powered down. This inhibits current backflow into the device which prevents damage to the device.

The V_{CC} isolation feature ensures that if either V_{CC} input is at GND, both ports are in the high-impedance state.

To ensure the high-impedance state during power up or power down, tie \overline{OE} to V_{CC} through a pullup resistor; the current-sinking capability of the driver determines the minimum value of the resistor.

6 Pin Configuration and Functions

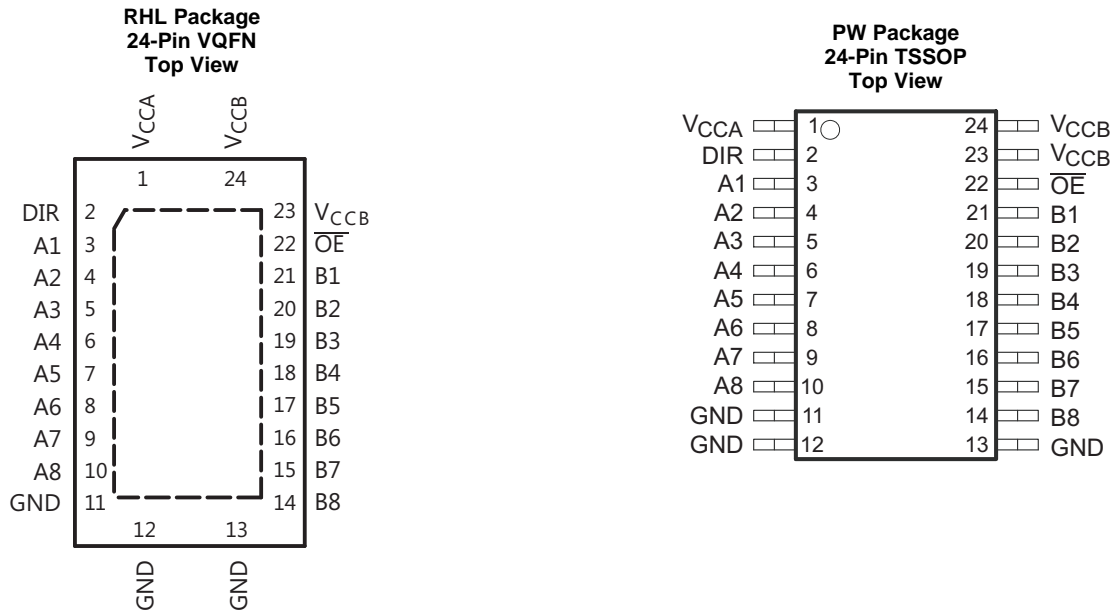

Pin Functions

| NAME | PIN | | TYPE | DESCRIPTION |
|------|--------|------------|------|--|
| | VQFN | TSSOP | | |
| A1 | 3 | 3 | I/O | Input/output A1. Referenced to V_{CCA} . |
| A2 | 4 | 4 | I/O | Input/output A2. Referenced to V_{CCA} . |
| A3 | 5 | 5 | I/O | Input/output A3. Referenced to V_{CCA} . |
| A4 | 6 | 6 | I/O | Input/output A4. Referenced to V_{CCA} . |
| A5 | 7 | 7 | I/O | Input/output A5. Referenced to V_{CCA} . |
| A6 | 8 | 8 | I/O | Input/output A6. Referenced to V_{CCA} . |
| A7 | 9 | 9 | I/O | Input/output A7. Referenced to V_{CCA} . |
| A8 | 10 | 10 | I/O | Input/output A8. Referenced to V_{CCA} . |
| B1 | 21 | 21 | I/O | Input/output B1. Referenced to V_{CCB} . |
| B2 | 20 | 20 | I/O | Input/output B2. Referenced to V_{CCB} . |
| B3 | 19 | 19 | I/O | Input/output B3. Referenced to V_{CCB} . |
| B4 | 18 | 18 | I/O | Input/output B4. Referenced to V_{CCB} . |
| B5 | 17 | 17 | I/O | Input/output B5. Referenced to V_{CCB} . |
| B6 | 16 | 16 | I/O | Input/output B6. Referenced to V_{CCB} . |
| B7 | 15 | 15 | I/O | Input/output B7. Referenced to V_{CCB} . |
| B8 | 14 | 14 | I/O | Input/output B8. Referenced to V_{CCB} . |
| DIR | 2 | — | I | Direction-control input for 1 ports |
| GND | 12, 13 | 11, 12, 13 | — | Ground |

Pin Functions (continued)

| PIN | | | TYPE | DESCRIPTION |
|-----------------|--------|--------|------|---|
| NAME | VQFN | TSSOP | | |
| \overline{OE} | 22 | 22 | I | 3-state output-mode enable. Pull \overline{OE} high to place '2' outputs in 3-state mode. Referenced to V_{CCA} . |
| Thermal pad | — | — | — | The exposed thermal pad must be connected as a secondary GND or be left electrically open. |
| V_{CCA} | 1 | 1 | — | A-port power supply voltage. $1.2\text{ V} \leq V_{CCA} \leq 3.6\text{ V}$ |
| V_{CCB} | 23, 24 | 23, 24 | — | B-port power supply voltage. $1.2\text{ V} \leq V_{CCB} \leq 3.6\text{ V}$ |

7 Specifications

7.1 Absolute Maximum Ratings

 over operating free-air temperature range (unless otherwise noted)⁽¹⁾

| | | | MIN | MAX | UNIT |
|-----------|---|--------------------|------|-------------------|------|
| V_{CCA} | Supply voltage | | -0.5 | 4.6 | V |
| V_{CCB} | | | | | |
| V_I | Input voltage ⁽²⁾ | I/O ports (A port) | -0.5 | 4.6 | V |
| | | I/O ports (B port) | -0.5 | 4.6 | V |
| | | Control inputs | -0.5 | 4.6 | V |
| V_O | Voltage range applied to any output in the high-impedance or power-off state ⁽²⁾ | A port | -0.5 | 4.6 | V |
| | | B port | -0.5 | 4.6 | V |
| V_O | Voltage range applied to any output in the high or low state ^{(2) (3)} | A port | -0.5 | $(V_{CCA} + 0.5)$ | V |
| | | B port | -0.5 | $(V_{CCB} + 0.5)$ | V |
| I_{IK} | Input clamp current | $V_I < 0$ | | -50 | mA |
| I_{OK} | Output clamp current | $V_O < 0$ | | -50 | mA |
| I_O | Continuous output current | | | ±50 | mA |
| | Continuous current through V_{CCA} , V_{CCB} , or GND | | | ±100 | mA |
| T_J | Junction temperature | | | 150 | °C |
| T_{stg} | Storage temperature | | -65 | 150 | °C |

- Stresses beyond those listed under *Absolute Maximum Ratings* may cause permanent damage to the device. These are stress ratings only, and functional operation of the device at these or any other conditions beyond those indicated under *Recommended Operating Conditions* is not implied. Exposure to absolute-maximum-rated conditions for extended periods may affect device reliability.
- The device withstands voltages in excess of input voltage and output negative-voltage ratings while operating within the input and output current ratings.
- The device withstands voltages in excess of the output positive-voltage rating up to 4.6 V maximum while operating within the output current rating.

7.2 ESD Ratings

| | | | VALUE | UNIT |
|-------------|-------------------------|---|-------|------|
| $V_{(ESD)}$ | Electrostatic discharge | Human-body model (HBM), per AEC Q100-002 Classification Level H2 ⁽¹⁾ | ±2000 | V |
| | | Charged-device model (CDM), per AEC Q100-011 Classification Level C3B | ±750 | |

- AEC Q100-002 indicates that HBM stressing shall be in accordance with the ANSI/ESDA/JEDEC JS-001 specification.

7.3 Recommended Operating Conditions

See (1) (2) (3)

| | | V_{CCI} | V_{CCO} | MIN | MAX | UNIT |
|-----------------------|------------------------------------|-----------------------------------|------------------|-----------------------|-----------|--------|
| V_{CCA} | Supply voltage | | | 1.2 | 3.6 | V |
| V_{CCB} | Supply voltage | | | 1.2 | 3.6 | V |
| V_{IH} | High-level input voltage | Data inputs | 1.2 V to 1.95 V | $V_{CCI} \times 0.65$ | | V |
| | | | 1.95 V to 2.7 V | 1.6 | | |
| | | | 2.7 V to 3.6 V | 2 | | |
| V_{IL} | Low-level input voltage | Data inputs | 1.2 V to 1.95 V | $V_{CCI} \times 0.35$ | | V |
| | | | 1.95 V to 2.7 V | 0.7 | | |
| | | | 2.7 V to 3.6 V | 0.8 | | |
| V_{IH} | High-level input voltage | DIR (referenced to V_{CCA}) | 1.2 V to 1.95 V | $V_{CCA} \times 0.65$ | | V |
| | | | 1.95 V to 2.7 V | 1.6 | | |
| | | | 2.7 V to 3.6 V | 2 | | |
| V_{IL} | Low-level input voltage | DIR (referenced to V_{CCA}) | 1.2 V to 1.95 V | $V_{CCA} \times 0.35$ | | V |
| | | | 1.95 V to 2.7 V | 0.7 | | |
| | | | 2.7 V to 3.6 V | 0.8 | | |
| V_I | Input voltage | | | 0 | 3.6 | V |
| V_O | Output voltage | Active state | | 0 | V_{CCO} | V |
| | | 3-state | | 0 | 3.6 | |
| I_{OH} | High-level output current | | 1.2 V | -3 | | mA |
| | | | 1.4 V to 1.6 V | -6 | | |
| | | | 1.65 V to 1.95 V | -8 | | |
| | | | 2.3 V to 2.7 V | -9 | | |
| | | | 3 V to 3.6 V | -12 | | |
| I_{OL} | Low-level output current | | 1.2 V | 3 | | mA |
| | | | 1.4 V to 1.6 V | 6 | | |
| | | | 1.65 V to 1.95 V | 8 | | |
| | | | 2.3 V to 2.7 V | 9 | | |
| | | | 3 V to 3.6 V | 12 | | |
| $\Delta t / \Delta v$ | Input transition rise or fall rate | | | | 5 | ns / V |
| T_A | Operating free-air temperature | | | -40 | 125 | °C |

 (1) V_{CCI} is the V_{CC} associated with the input port.

 (2) V_{CCO} is the V_{CC} associated with the output port.

 (3) Hold all unused data inputs of the device at V_{CCI} or GND to assure proper device operation. See the TI application report, [Implications of Slow or Floating CMOS Inputs](#), SCBA004.

7.4 Thermal Information

| THERMAL METRIC ⁽¹⁾ | | SN74AVC8T245-Q1 | UNIT |
|-------------------------------|--|-----------------|------|
| | | RHL (VQFN) | |
| | | 24 PINS | |
| $R_{\theta JA}$ | Junction-to-ambient thermal resistance | 35 | °C/W |
| $R_{\theta JC(top)}$ | Junction-to-case (top) thermal resistance | 39.9 | °C/W |
| $R_{\theta JB}$ | Junction-to-board thermal resistance | 13.8 | °C/W |
| ψ_{JT} | Junction-to-top characterization parameter | 0.3 | °C/W |
| ψ_{JB} | Junction-to-board characterization parameter | 13.8 | °C/W |
| $R_{\theta JC(bot)}$ | Junction-to-case (bottom) thermal resistance | 1.4 | °C/W |

(1) For more information about traditional and new thermal metrics, see the [Semiconductor and IC Package Thermal Metrics](#) application report.

7.5 Electrical Characteristics

over recommended operating free-air temperature range (unless otherwise noted)⁽¹⁾ ⁽²⁾

| PARAMETER | | TEST CONDITIONS | V_{CCA} | V_{CCB} | T_A | MIN | TYP | MAX | UNIT |
|----------------|----------------|--|----------------|----------------|---|-----------------|------------|---------|---------------|
| V_{OH} | | $V_I = V_{IH}$ | 1.2 V to 3.6 V | 1.2 V to 3.6 V | $T_A = -40^\circ\text{C}$ to $+125^\circ\text{C}$ | $V_{CCO} - 0.2$ | 0.95 | 1 | V |
| | | | | | $T_A = 25^\circ\text{C}$ | | | | |
| | | | | | $T_A = -40^\circ\text{C}$ to $+125^\circ\text{C}$ | | | | |
| | | | | | $T_A = -40^\circ\text{C}$ to $+125^\circ\text{C}$ | | | | |
| | | | | | $T_A = -40^\circ\text{C}$ to $+125^\circ\text{C}$ | | | | |
| | | | | | $T_A = -40^\circ\text{C}$ to $+125^\circ\text{C}$ | | | | |
| V_{OL} | | $V_I = V_{IL}$ | 1.2 V to 3.6 V | 1.2 V to 3.6 V | $T_A = -40^\circ\text{C}$ to $+125^\circ\text{C}$ | 0.2 | 0.15 | 0.35 | V |
| | | | | | $T_A = 25^\circ\text{C}$ | | | | |
| | | | | | $T_A = -40^\circ\text{C}$ to $+125^\circ\text{C}$ | | | | |
| | | | | | $T_A = -40^\circ\text{C}$ to $+125^\circ\text{C}$ | | | | |
| | | | | | $T_A = -40^\circ\text{C}$ to $+125^\circ\text{C}$ | | | | |
| | | | | | $T_A = -40^\circ\text{C}$ to $+125^\circ\text{C}$ | | | | |
| I_i | Control inputs | $V_I = V_{CCA}$ or GND | 1.2 V to 3.6 V | 1.2 V to 3.6 V | $T_A = 25^\circ\text{C}$ | ± 0.02 5 | ± 0.25 | ± 1 | μA |
| | | | | | $T_A = -40^\circ\text{C}$ to $+125^\circ\text{C}$ | | | | |
| I_{off} | A or B port | V_I or $V_O = 0$ to 3.6 V | 0 V | 0 V to 3.6 V | $T_A = 25^\circ\text{C}$ | ± 0.1 | ± 1 | ± 5 | μA |
| | | | | | $T_A = -40^\circ\text{C}$ to $+125^\circ\text{C}$ | | | | |
| | | | 0 V to 3.6 V | 0 V | $T_A = 25^\circ\text{C}$ | ± 0.1 | ± 1 | | |
| | | | | | $T_A = -40^\circ\text{C}$ to $+125^\circ\text{C}$ | | | | |
| $I_{OZ}^{(3)}$ | A or B port | $V_O = V_{CCO}$ or GND, $V_I = V_{CCI}$ or GND, $\overline{OE} = V_{IH}$ | 3.6 V | 3.6 V | $T_A = 25^\circ\text{C}$ | ± 0.5 | ± 2.5 | ± 5 | μA |
| | | | | | $T_A = -40^\circ\text{C}$ to $+125^\circ\text{C}$ | | | | |

(1) V_{CCO} is the V_{CC} associated with the output port.

(2) V_{CCI} is the V_{CC} associated with the input port.

(3) For I/O ports, the parameter I_{OZ} includes the input leakage current.

Electrical Characteristics (continued)

over recommended operating free-air temperature range (unless otherwise noted)^{(1) (2)}

| PARAMETER | | TEST CONDITIONS | V _{CCA} | V _{CCB} | T _A | MIN | TYP | MAX | UNIT |
|-------------------------------------|----------------|--|------------------|------------------|----------------------------------|-----|-----|-----|------|
| I _{CCA} | | V _I = V _{CCI} or GND ⁽⁴⁾ , I _O = 0 | 1.2 V to 3.6 V | 1.2 V to 3.6 V | T _A = -40°C to +125°C | | | 15 | μA |
| | | | 0 V | 3.6 V | T _A = -40°C to +125°C | | | -2 | |
| | | | 3.6 V | 0 V | T _A = -40°C to +125°C | | | 15 | |
| I _{CCB} | | V _I = V _{CC1} or GND ⁽⁴⁾ , I _O = 0 | 1.2 V to 3.6 V | 1.2 V to 3.6 V | T _A = -40°C to +125°C | | | 15 | μA |
| | | | 0 V | 3.6 V | T _A = -40°C to +125°C | | | 15 | |
| | | | 3.6 V | 0 V | T _A = -40°C to +125°C | | | -2 | |
| I _{CCA} + I _{CCB} | | V _I = V _{CC1} or GND, I _O = 0 | 1.2 V to 3.6 V | 1.2 V to 3.6 V | T _A = -40°C to +125°C | | | 25 | μA |
| C _i | Control inputs | V _I = 3.3 V or GND | 3.3 V | 3.3 V | T _A = 25°C | | 3.5 | | pF |
| C _{io} | A or B port | V _O = 3.3 V or GND | 3.3 V | 3.3 V | T _A = 25°C | | 6 | | pF |

(4) Hold all unused data inputs of the device at V_{CC1} or GND to assure proper device operation. See the TI application report, [Implications of Slow or Floating CMOS Inputs](#), SCBA004.

7.6 Switching Characteristics: V_{CCA} = 1.2 V

over recommended operating free-air temperature range, V_{CCA} = 1.2 V (see [Figure 12](#))

| PARAMETER | FROM (INPUT) | TO (OUTPUT) | V _{CCB} | TYP | UNIT |
|-------------------------------------|-----------------|-------------|--------------------------|-----|------|
| t _{PLH} , t _{PHL} | A | B | V _{CCB} = 1.2 V | 3.1 | ns |
| | | | V _{CCB} = 1.5 V | 2.6 | |
| | | | V _{CCB} = 1.8 V | 2.5 | |
| | | | V _{CCB} = 2.5 V | 3 | |
| | | | V _{CCB} = 3.3 V | 3.5 | |
| t _{PLH} , t _{PHL} | B | A | V _{CCB} = 1.2 V | 3.1 | ns |
| | | | V _{CCB} = 1.5 V | 2.7 | |
| | | | V _{CCB} = 1.8 V | 2.5 | |
| | | | V _{CCB} = 2.5 V | 2.4 | |
| | | | V _{CCB} = 3.3 V | 2.3 | |
| t _{PZH} , t _{PZL} | \overline{OE} | A | V _{CCB} = 1.2 V | 5.3 | ns |
| | | | V _{CCB} = 1.5 V | | |
| | | | V _{CCB} = 1.8 V | | |
| | | | V _{CCB} = 2.5 V | | |
| | | | V _{CCB} = 3.3 V | | |
| t _{PZH} , t _{PZL} | \overline{OE} | B | V _{CCB} = 1.2 V | 5.1 | ns |
| | | | V _{CCB} = 1.5 V | 4 | |
| | | | V _{CCB} = 1.8 V | 3.5 | |
| | | | V _{CCB} = 2.5 V | 3.2 | |
| | | | V _{CCB} = 3.3 V | 3.1 | |
| t _{PHZ} , t _{PLZ} | \overline{OE} | A | V _{CCB} = 1.2 V | 4.8 | ns |
| | | | V _{CCB} = 1.5 V | | |
| | | | V _{CCB} = 1.8 V | | |
| | | | V _{CCB} = 2.5 V | | |
| | | | V _{CCB} = 3.3 V | | |

Switching Characteristics: $V_{CCA} = 1.2\text{ V}$ (continued)

 over recommended operating free-air temperature range, $V_{CCA} = 1.2\text{ V}$ (see [Figure 12](#))

| PARAMETER | FROM (INPUT) | TO (OUTPUT) | V_{CCB} | TYP | UNIT |
|-----------------------|-----------------|-------------|--------------------------|-----|------|
| t_{PHZ} , t_{PLZ} | \overline{OE} | B | $V_{CCB} = 1.2\text{ V}$ | 4.7 | ns |
| | | | $V_{CCB} = 1.5\text{ V}$ | 4 | |
| | | | $V_{CCB} = 1.8\text{ V}$ | 4.1 | |
| | | | $V_{CCB} = 2.5\text{ V}$ | 4.3 | |
| | | | $V_{CCB} = 3.3\text{ V}$ | 5.1 | |

7.7 Switching Characteristics: $V_{CCA} = 1.5\text{ V} \pm 0.1\text{ V}$

 over recommended operating free-air temperature range, $V_{CCA} = 1.5\text{ V} \pm 0.1\text{ V}$ (see [Figure 12](#))

| PARAMETER | FROM (INPUT) | TO (OUTPUT) | V_{CCB} | MIN | TYP | MAX | UNIT |
|-----------------------|-----------------|-------------|--|-----|-----|------|------|
| t_{PLH} , t_{PHL} | A | B | $V_{CCB} = 1.2\text{ V}$ | | 3.1 | | ns |
| | | | $V_{CCB} = 1.5\text{ V} \pm 0.1\text{ V}$ | 0.5 | | 14.7 | |
| | | | $V_{CCB} = 1.8\text{ V} \pm 0.15\text{ V}$ | 0.5 | | 13.3 | |
| | | | $V_{CCB} = 2.5\text{ V} \pm 0.2\text{ V}$ | 0.5 | | 13.9 | |
| | | | $V_{CCB} = 3.3\text{ V} \pm 0.3\text{ V}$ | 0.5 | | 17.2 | |
| t_{PLH} , t_{PHL} | B | A | $V_{CCB} = 1.2\text{ V}$ | | 3.1 | | ns |
| | | | $V_{CCB} = 1.5\text{ V} \pm 0.1\text{ V}$ | 0.5 | | 14.7 | |
| | | | $V_{CCB} = 1.8\text{ V} \pm 0.15\text{ V}$ | 0.5 | | 14.2 | |
| | | | $V_{CCB} = 2.5\text{ V} \pm 0.2\text{ V}$ | 0.5 | | 13.5 | |
| | | | $V_{CCB} = 3.3\text{ V} \pm 0.3\text{ V}$ | 0.5 | | 13.2 | |
| t_{PZH} , t_{PZL} | \overline{OE} | A | $V_{CCB} = 1.2\text{ V}$ | | 5.3 | | ns |
| | | | $V_{CCB} = 1.5\text{ V} \pm 0.1\text{ V}$ | 0.5 | | 20.5 | |
| | | | $V_{CCB} = 1.8\text{ V} \pm 0.15\text{ V}$ | 0.5 | | 20.5 | |
| | | | $V_{CCB} = 2.5\text{ V} \pm 0.2\text{ V}$ | 0.5 | | 20.5 | |
| | | | $V_{CCB} = 3.3\text{ V} \pm 0.3\text{ V}$ | 0.5 | | 20.5 | |
| t_{PZH} , t_{PZL} | \overline{OE} | B | $V_{CCB} = 1.2\text{ V}$ | | 5.1 | | ns |
| | | | $V_{CCB} = 1.5\text{ V} \pm 0.1\text{ V}$ | 0.5 | | 18.6 | |
| | | | $V_{CCB} = 1.8\text{ V} \pm 0.15\text{ V}$ | 0.5 | | 17.7 | |
| | | | $V_{CCB} = 2.5\text{ V} \pm 0.2\text{ V}$ | 0.5 | | 15.1 | |
| | | | $V_{CCB} = 3.3\text{ V} \pm 0.3\text{ V}$ | 0.5 | | 14.4 | |
| t_{PHZ} , t_{PLZ} | \overline{OE} | A | $V_{CCB} = 1.2\text{ V}$ | | 4.8 | | ns |
| | | | $V_{CCB} = 1.5\text{ V} \pm 0.1\text{ V}$ | 0.5 | | 20.3 | |
| | | | $V_{CCB} = 1.8\text{ V} \pm 0.15\text{ V}$ | 0.5 | | 20.3 | |
| | | | $V_{CCB} = 2.5\text{ V} \pm 0.2\text{ V}$ | 0.5 | | 20.3 | |
| | | | $V_{CCB} = 3.3\text{ V} \pm 0.3\text{ V}$ | 0.5 | | 20.3 | |
| t_{PHZ} , t_{PLZ} | \overline{OE} | B | $V_{CCB} = 1.2\text{ V}$ | | 4.7 | | ns |
| | | | $V_{CCB} = 1.5\text{ V} \pm 0.1\text{ V}$ | 0.5 | | 20.0 | |
| | | | $V_{CCB} = 1.8\text{ V} \pm 0.15\text{ V}$ | 0.5 | | 18.6 | |
| | | | $V_{CCB} = 2.5\text{ V} \pm 0.2\text{ V}$ | 0.5 | | 17.9 | |
| | | | $V_{CCB} = 3.3\text{ V} \pm 0.3\text{ V}$ | 0.5 | | 18.9 | |

7.8 Switching Characteristics: $V_{CCA} = 1.8\text{ V} \pm 0.15\text{ V}$

over recommended operating free-air temperature range, $V_{CCA} = 1.8\text{ V} \pm 0.15\text{ V}$ (see Figure 12)

| PARAMETER | FROM (INPUT) | TO (OUTPUT) | V_{CCB} | MIN | TYP | MAX | UNIT |
|-----------------------|-----------------|-------------|--|-----|-----|------|------|
| t_{PLH} , t_{PHL} | A | B | $V_{CCB} = 1.2\text{ V}$ | | 2.5 | | ns |
| | | | $V_{CCB} = 1.5\text{ V} \pm 0.1\text{ V}$ | 0.5 | | 14.2 | |
| | | | $V_{CCB} = 1.8\text{ V} \pm 0.15\text{ V}$ | 0.5 | | 13.0 | |
| | | | $V_{CCB} = 2.5\text{ V} \pm 0.2\text{ V}$ | 0.5 | | 12.3 | |
| | | | $V_{CCB} = 3.3\text{ V} \pm 0.3\text{ V}$ | 0.5 | | 12.1 | |
| t_{PLH} , t_{PHL} | B | A | $V_{CCB} = 1.2\text{ V}$ | | 2.5 | | ns |
| | | | $V_{CCB} = 1.5\text{ V} \pm 0.1\text{ V}$ | 0.5 | | 13.3 | |
| | | | $V_{CCB} = 1.8\text{ V} \pm 0.15\text{ V}$ | 0.5 | | 13.0 | |
| | | | $V_{CCB} = 2.5\text{ V} \pm 0.2\text{ V}$ | 0.5 | | 12.1 | |
| | | | $V_{CCB} = 3.3\text{ V} \pm 0.3\text{ V}$ | 0.5 | | 11.8 | |
| t_{PZH} , t_{PZL} | \overline{OE} | A | $V_{CCB} = 1.2\text{ V}$ | | 3 | | ns |
| | | | $V_{CCB} = 1.5\text{ V} \pm 0.1\text{ V}$ | 0.5 | | 17.2 | |
| | | | $V_{CCB} = 1.8\text{ V} \pm 0.15\text{ V}$ | 0.5 | | 17.2 | |
| | | | $V_{CCB} = 2.5\text{ V} \pm 0.2\text{ V}$ | 0.5 | | 17.2 | |
| | | | $V_{CCB} = 3.3\text{ V} \pm 0.3\text{ V}$ | 0.5 | | 17.2 | |
| t_{PZH} , t_{PZL} | \overline{OE} | B | $V_{CCB} = 1.2\text{ V}$ | | 4.6 | | ns |
| | | | $V_{CCB} = 1.5\text{ V} \pm 0.1\text{ V}$ | 0.5 | | 19.6 | |
| | | | $V_{CCB} = 1.8\text{ V} \pm 0.15\text{ V}$ | 0.5 | | 17.0 | |
| | | | $V_{CCB} = 2.5\text{ V} \pm 0.2\text{ V}$ | 0.5 | | 14.2 | |
| | | | $V_{CCB} = 3.3\text{ V} \pm 0.3\text{ V}$ | 0.5 | | 13.2 | |
| t_{PHZ} , t_{PLZ} | \overline{OE} | A | $V_{CCB} = 1.2\text{ V}$ | | 2.8 | | ns |
| | | | $V_{CCB} = 1.5\text{ V} \pm 0.1\text{ V}$ | 0.5 | | 17.7 | |
| | | | $V_{CCB} = 1.8\text{ V} \pm 0.15\text{ V}$ | 0.5 | | 17.7 | |
| | | | $V_{CCB} = 2.5\text{ V} \pm 0.2\text{ V}$ | 0.5 | | 17.7 | |
| | | | $V_{CCB} = 3.3\text{ V} \pm 0.3\text{ V}$ | 0.5 | | 17.7 | |
| t_{PHZ} , t_{PLZ} | \overline{OE} | B | $V_{CCB} = 1.2\text{ V}$ | | 3.9 | | ns |
| | | | $V_{CCB} = 1.5\text{ V} \pm 0.1\text{ V}$ | 0.5 | | 18.9 | |
| | | | $V_{CCB} = 1.8\text{ V} \pm 0.15\text{ V}$ | 0.5 | | 17.3 | |
| | | | $V_{CCB} = 2.5\text{ V} \pm 0.2\text{ V}$ | 0.5 | | 15.8 | |
| | | | $V_{CCB} = 3.3\text{ V} \pm 0.3\text{ V}$ | 0.5 | | 15.4 | |

7.9 Switching Characteristics: $V_{CCA} = 2.5\text{ V} \pm 0.2\text{ V}$

over recommended operating free-air temperature range, $V_{CCA} = 2.5\text{ V} \pm 0.2\text{ V}$ (see Figure 12)

| PARAMETER | FROM (INPUT) | TO (OUTPUT) | V_{CCB} | MIN | TYP | MAX | UNIT |
|-----------------------|--------------|-------------|--|-----|-----|------|------|
| t_{PLH} , t_{PHL} | A | B | $V_{CCB} = 1.2\text{ V}$ | | 2.4 | | ns |
| | | | $V_{CCB} = 1.5\text{ V} \pm 0.1\text{ V}$ | 0.5 | | 13.5 | |
| | | | $V_{CCB} = 1.8\text{ V} \pm 0.15\text{ V}$ | 0.5 | | 12.1 | |
| | | | $V_{CCB} = 2.5\text{ V} \pm 0.2\text{ V}$ | 0.5 | | 10.7 | |
| | | | $V_{CCB} = 3.3\text{ V} \pm 0.3\text{ V}$ | 0.5 | | 10.2 | |
| t_{PLH} , t_{PHL} | B | A | $V_{CCB} = 1.2\text{ V}$ | | 3 | | ns |
| | | | $V_{CCB} = 1.5\text{ V} \pm 0.1\text{ V}$ | 0.5 | | 13.9 | |
| | | | $V_{CCB} = 1.8\text{ V} \pm 0.15\text{ V}$ | 0.5 | | 12.3 | |
| | | | $V_{CCB} = 2.5\text{ V} \pm 0.2\text{ V}$ | 0.5 | | 10.7 | |
| | | | $V_{CCB} = 3.3\text{ V} \pm 0.3\text{ V}$ | 0.5 | | 10.4 | |

Switching Characteristics: $V_{CCA} = 2.5 \text{ V} \pm 0.2 \text{ V}$ (continued)

 over recommended operating free-air temperature range, $V_{CCA} = 2.5 \text{ V} \pm 0.2 \text{ V}$ (see [Figure 12](#))

| PARAMETER | FROM (INPUT) | TO (OUTPUT) | V_{CCB} | MIN | TYP | MAX | UNIT |
|--------------------|-----------------|-------------|--|-----|-----|------|------|
| t_{PZH}, t_{PZL} | \overline{OE} | A | $V_{CCB} = 1.2 \text{ V}$ | | 2.2 | | ns |
| | | | $V_{CCB} = 1.5 \text{ V} \pm 0.1 \text{ V}$ | 0.5 | | 13.7 | |
| | | | $V_{CCB} = 1.8 \text{ V} \pm 0.15 \text{ V}$ | 0.5 | | 13.7 | |
| | | | $V_{CCB} = 2.5 \text{ V} \pm 0.2 \text{ V}$ | 0.5 | | 13.7 | |
| | | | $V_{CCB} = 3.3 \text{ V} \pm 0.3 \text{ V}$ | 0.5 | | 13.7 | |
| t_{PZH}, t_{PZL} | \overline{OE} | B | $V_{CCB} = 1.2 \text{ V}$ | | 4.5 | | ns |
| | | | $V_{CCB} = 1.5 \text{ V} \pm 0.1 \text{ V}$ | 0.5 | | 19.1 | |
| | | | $V_{CCB} = 1.8 \text{ V} \pm 0.15 \text{ V}$ | 0.5 | | 16.5 | |
| | | | $V_{CCB} = 2.5 \text{ V} \pm 0.2 \text{ V}$ | 0.5 | | 13.3 | |
| | | | $V_{CCB} = 3.3 \text{ V} \pm 0.3 \text{ V}$ | 0.5 | | 12.3 | |
| t_{PHZ}, t_{PLZ} | \overline{OE} | A | $V_{CCB} = 1.2 \text{ V}$ | | 1.8 | | ns |
| | | | $V_{CCB} = 1.5 \text{ V} \pm 0.1 \text{ V}$ | 0.5 | | 14.2 | |
| | | | $V_{CCB} = 1.8 \text{ V} \pm 0.15 \text{ V}$ | 0.5 | | 14.2 | |
| | | | $V_{CCB} = 2.5 \text{ V} \pm 0.2 \text{ V}$ | 0.5 | | 14.2 | |
| | | | $V_{CCB} = 3.3 \text{ V} \pm 0.3 \text{ V}$ | 0.5 | | 14.2 | |
| t_{PHZ}, t_{PLZ} | \overline{OE} | B | $V_{CCB} = 1.2 \text{ V}$ | | 3.6 | | ns |
| | | | $V_{CCB} = 1.5 \text{ V} \pm 0.1 \text{ V}$ | 0.5 | | 17.7 | |
| | | | $V_{CCB} = 1.8 \text{ V} \pm 0.15 \text{ V}$ | 0.5 | | 16.3 | |
| | | | $V_{CCB} = 2.5 \text{ V} \pm 0.2 \text{ V}$ | 0.5 | | 14.2 | |
| | | | $V_{CCB} = 3.3 \text{ V} \pm 0.3 \text{ V}$ | 0.5 | | 12.1 | |

7.10 Switching Characteristics: $V_{CCA} = 3.3 \text{ V} \pm 0.3 \text{ V}$

 over recommended operating free-air temperature range, $V_{CCA} = 3.3 \text{ V} \pm 0.3 \text{ V}$ (see [Figure 12](#))

| PARAMETER | FROM (INPUT) | TO (OUTPUT) | V_{CCB} | MIN | TYP | MAX | UNIT |
|--------------------|-----------------|-------------|--|-----|-----|------|------|
| t_{PLH}, t_{PHL} | A | B | $V_{CCB} = 1.2 \text{ V}$ | | 2.3 | | ns |
| | | | $V_{CCB} = 1.5 \text{ V} \pm 0.1 \text{ V}$ | 0.5 | | 13.2 | |
| | | | $V_{CCB} = 1.8 \text{ V} \pm 0.15 \text{ V}$ | 0.5 | | 11.1 | |
| | | | $V_{CCB} = 2.5 \text{ V} \pm 0.2 \text{ V}$ | 0.5 | | 10.4 | |
| | | | $V_{CCB} = 3.3 \text{ V} \pm 0.3 \text{ V}$ | 0.5 | | 9.7 | |
| t_{PLH}, t_{PHL} | B | A | $V_{CCB} = 1.2 \text{ V}$ | | 3.5 | | ns |
| | | | $V_{CCB} = 1.5 \text{ V} \pm 0.1 \text{ V}$ | 0.5 | | 17.2 | |
| | | | $V_{CCB} = 1.8 \text{ V} \pm 0.15 \text{ V}$ | 0.5 | | 12.1 | |
| | | | $V_{CCB} = 2.5 \text{ V} \pm 0.2 \text{ V}$ | 0.5 | | 10.2 | |
| | | | $V_{CCB} = 3.3 \text{ V} \pm 0.3 \text{ V}$ | 0.5 | | 9.7 | |
| t_{PZH}, t_{PZL} | \overline{OE} | A | $V_{CCB} = 1.2 \text{ V}$ | | 2 | | ns |
| | | | $V_{CCB} = 1.5 \text{ V} \pm 0.1 \text{ V}$ | 0.5 | | 12.3 | |
| | | | $V_{CCB} = 1.8 \text{ V} \pm 0.15 \text{ V}$ | 0.5 | | 12.3 | |
| | | | $V_{CCB} = 2.5 \text{ V} \pm 0.2 \text{ V}$ | 0.5 | | 12.3 | |
| | | | $V_{CCB} = 3.3 \text{ V} \pm 0.3 \text{ V}$ | 0.5 | | 12.3 | |
| t_{PZH}, t_{PZL} | \overline{OE} | B | $V_{CCB} = 1.2 \text{ V}$ | | 4.5 | | ns |
| | | | $V_{CCB} = 1.5 \text{ V} \pm 0.1 \text{ V}$ | 0.5 | | 18.9 | |
| | | | $V_{CCB} = 1.8 \text{ V} \pm 0.15 \text{ V}$ | 0.5 | | 16.1 | |
| | | | $V_{CCB} = 2.5 \text{ V} \pm 0.2 \text{ V}$ | 0.5 | | 13.2 | |
| | | | $V_{CCB} = 3.3 \text{ V} \pm 0.3 \text{ V}$ | 0.5 | | 12.3 | |

Switching Characteristics: $V_{CCA} = 3.3 \text{ V} \pm 0.3 \text{ V}$ (continued)

 over recommended operating free-air temperature range, $V_{CCA} = 3.3 \text{ V} \pm 0.3 \text{ V}$ (see [Figure 12](#))

| PARAMETER | FROM (INPUT) | TO (OUTPUT) | V_{CCB} | MIN | TYP | MAX | UNIT |
|--------------------|-----------------|-------------|--|-----|-----|------|------|
| t_{PHZ}, t_{PLZ} | \overline{OE} | A | $V_{CCB} = 1.2 \text{ V}$ | | 1.7 | | ns |
| | | | $V_{CCB} = 1.5 \text{ V} \pm 0.1 \text{ V}$ | 0.5 | | 12.3 | |
| | | | $V_{CCB} = 1.8 \text{ V} \pm 0.15 \text{ V}$ | 0.5 | | 12.3 | |
| | | | $V_{CCB} = 2.5 \text{ V} \pm 0.2 \text{ V}$ | 0.5 | | 12.3 | |
| | | | $V_{CCB} = 3.3 \text{ V} \pm 0.3 \text{ V}$ | 0.5 | | 12.3 | |
| t_{PHZ}, t_{PLZ} | \overline{OE} | B | $V_{CCB} = 1.2 \text{ V}$ | | 3.4 | | ns |
| | | | $V_{CCB} = 1.5 \text{ V} \pm 0.1 \text{ V}$ | 0.5 | | 17.4 | |
| | | | $V_{CCB} = 1.8 \text{ V} \pm 0.15 \text{ V}$ | 0.5 | | 15.8 | |
| | | | $V_{CCB} = 2.5 \text{ V} \pm 0.2 \text{ V}$ | 0.5 | | 13.7 | |
| | | | $V_{CCB} = 3.3 \text{ V} \pm 0.3 \text{ V}$ | 0.5 | | 12.6 | |

7.11 Operating Characteristics
 $T_A = 25^\circ\text{C}$

| PARAMETER | | TEST CONDITIONS | | V_{CCA} | TYP | UNIT |
|-----------------|------------------|---|---|-------------------------------------|-----|------|
| $C_{pdA}^{(1)}$ | A to B | Outputs enabled | $C_L = 0,$ $f = 10 \text{ MHz},$ $t_r = t_f = 1 \text{ ns}$ | $V_{CCA} = V_{CCB} = 1.2 \text{ V}$ | 1 | pF |
| | | | | $V_{CCA} = V_{CCB} = 1.5 \text{ V}$ | | |
| | | | | $V_{CCA} = V_{CCB} = 1.8 \text{ V}$ | | |
| | | | | $V_{CCA} = V_{CCB} = 2.5 \text{ V}$ | | |
| | | | | $V_{CCA} = V_{CCB} = 3.3 \text{ V}$ | | |
| | | Outputs disabled | $C_L = 0,$ $f = 10 \text{ MHz},$ $t_r = t_f = 1 \text{ ns}$ | $V_{CCA} = V_{CCB} = 1.2 \text{ V}$ | 1 | |
| | | | | $V_{CCA} = V_{CCB} = 1.5 \text{ V}$ | | |
| | | | | $V_{CCA} = V_{CCB} = 1.8 \text{ V}$ | | |
| | | | | $V_{CCA} = V_{CCB} = 2.5 \text{ V}$ | | |
| | | | | $V_{CCA} = V_{CCB} = 3.3 \text{ V}$ | | |
| | B to A | Outputs enabled | $C_L = 0,$ $f = 10 \text{ MHz},$ $t_r = t_f = 1 \text{ ns}$ | $V_{CCA} = V_{CCB} = 1.2 \text{ V}$ | 12 | |
| | | | | $V_{CCA} = V_{CCB} = 1.5 \text{ V}$ | 12 | |
| | | | | $V_{CCA} = V_{CCB} = 1.8 \text{ V}$ | 12 | |
| | | | | $V_{CCA} = V_{CCB} = 2.5 \text{ V}$ | 13 | |
| B to A | Outputs disabled | $C_L = 0,$ $f = 10 \text{ MHz},$ $t_r = t_f = 1 \text{ ns}$ | $V_{CCA} = V_{CCB} = 1.2 \text{ V}$ | 1 | | |
| | | | $V_{CCA} = V_{CCB} = 1.5 \text{ V}$ | | | |
| | | | $V_{CCA} = V_{CCB} = 1.8 \text{ V}$ | | | |
| | | | $V_{CCA} = V_{CCB} = 2.5 \text{ V}$ | | | |
| | | | $V_{CCA} = V_{CCB} = 3.3 \text{ V}$ | | | |

(1) Power dissipation capacitance per transceiver

Operating Characteristics (continued)
 $T_A = 25^\circ\text{C}$

| PARAMETER | | TEST CONDITIONS | V_{CCA} | TYP | UNIT | |
|------------------------------------|--------|------------------|---|---|------------------------------------|----|
| $C_{pdB}^{(1)}$ | A to B | Outputs enabled | $C_L = 0,$ $f = 10\text{ MHz},$ $t_r = t_f = 1\text{ ns}$ | $V_{CCA} = V_{CCB} = 1.2\text{ V}$ | 12 | pF |
| | | | | $V_{CCA} = V_{CCB} = 1.5\text{ V}$ | 12 | |
| | | | | $V_{CCA} = V_{CCB} = 1.8\text{ V}$ | 12 | |
| | | | | $V_{CCA} = V_{CCB} = 2.5\text{ V}$ | 13 | |
| | | | | $V_{CCA} = V_{CCB} = 3.3\text{ V}$ | 14 | |
| | A to B | Outputs disabled | $C_L = 0,$ $f = 10\text{ MHz},$ $t_r = t_f = 1\text{ ns}$ | $V_{CCA} = V_{CCB} = 1.2\text{ V}$ | 1 | |
| | | | | $V_{CCA} = V_{CCB} = 1.5\text{ V}$ | | |
| | | | | $V_{CCA} = V_{CCB} = 1.8\text{ V}$ | | |
| | | | | $V_{CCA} = V_{CCB} = 2.5\text{ V}$ | | |
| | | | | $V_{CCA} = V_{CCB} = 3.3\text{ V}$ | | |
| | B to A | Outputs enabled | $C_L = 0,$ $f = 10\text{ MHz},$ $t_r = t_f = 1\text{ ns}$ | $V_{CCA} = V_{CCB} = 1.2\text{ V}$ | 1 | |
| | | | | $V_{CCA} = V_{CCB} = 1.5\text{ V}$ | | |
| | | | | $V_{CCA} = V_{CCB} = 1.8\text{ V}$ | | |
| | | | | $V_{CCA} = V_{CCB} = 2.5\text{ V}$ | | |
| | | | | $V_{CCA} = V_{CCB} = 3.3\text{ V}$ | | |
| | | B to A | Outputs disabled | $C_L = 0,$ $f = 10\text{ MHz},$ $t_r = t_f = 1\text{ ns}$ | $V_{CCA} = V_{CCB} = 1.2\text{ V}$ | |
| $V_{CCA} = V_{CCB} = 1.5\text{ V}$ | | | | | | |
| $V_{CCA} = V_{CCB} = 1.8\text{ V}$ | | | | | | |
| $V_{CCA} = V_{CCB} = 2.5\text{ V}$ | | | | | | |
| $V_{CCA} = V_{CCB} = 3.3\text{ V}$ | | | | | | |

Table 1. Typical Total Static Current Consumption ($I_{CCA} + I_{CCB}$)

| V_{CCB} | V_{CCA} | | | | | | UNIT |
|-----------|-----------|-------|-------|-------|-------|-------|---------------|
| | 0 V | 1.2 V | 1.5 V | 1.8 V | 2.5 V | 3.3 V | |
| 0 V | 0 | <0.5 | <0.5 | <0.5 | <0.5 | <0.5 | μA |
| 1.2 V | <0.5 | <1 | <1 | <1 | <1 | 1 | μA |
| 1.5 V | <0.5 | <1 | <1 | <1 | <1 | 1 | μA |
| 1.8 V | <0.5 | <1 | <1 | <1 | <1 | <1 | μA |
| 2.5 V | <0.5 | 1 | <1 | <1 | <1 | <1 | μA |
| 3.3 V | <0.5 | 1 | <1 | <1 | <1 | <1 | μA |

7.12 Typical Characteristics

T_A = 25°C

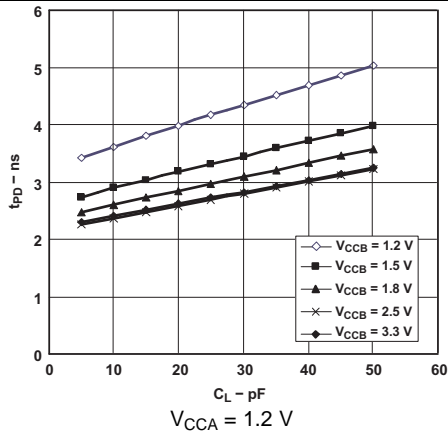

Figure 1. Typical Propagation Delay (A to B) vs Load Capacitance

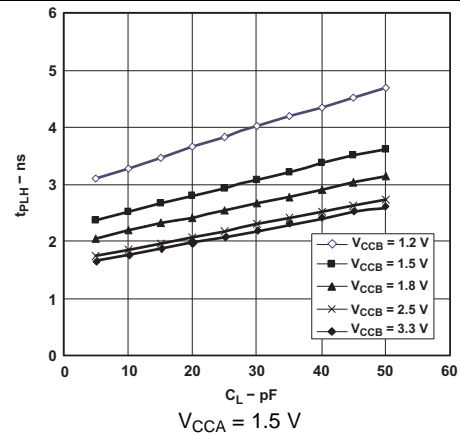

Figure 2. Typical Propagation Delay (A to B) vs Load Capacitance

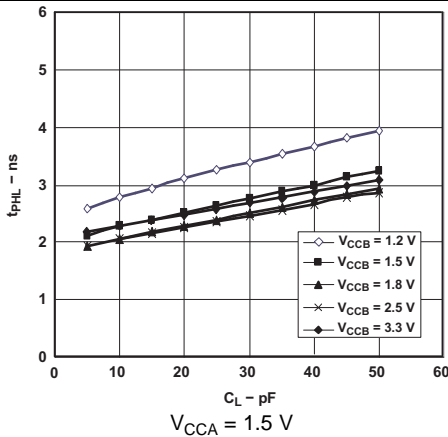

Figure 3. Typical Propagation Delay (A to B) vs Load Capacitance

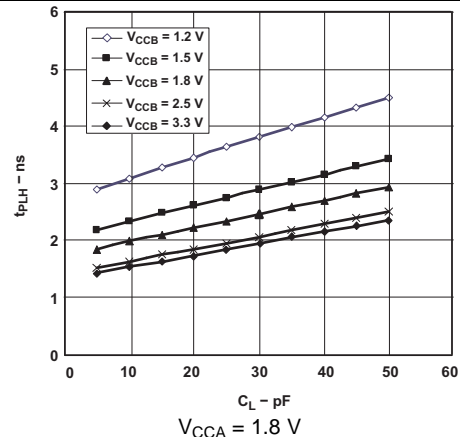

Figure 4. Typical Propagation Delay (A to B) vs Load Capacitance

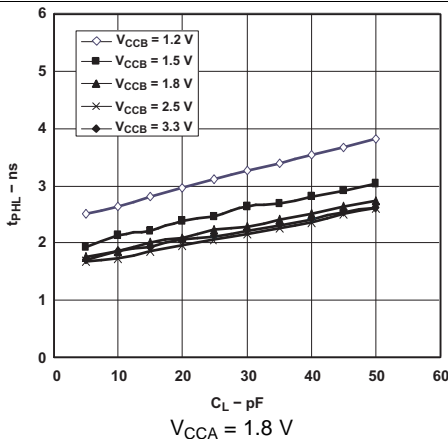

Figure 5. Typical Propagation Delay (A to B) vs Load Capacitance

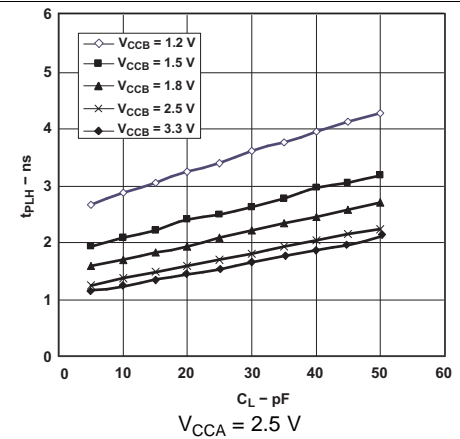

Figure 6. Typical Propagation Delay (A to B) vs Load Capacitance

Typical Characteristics (continued)

T_A = 25°C

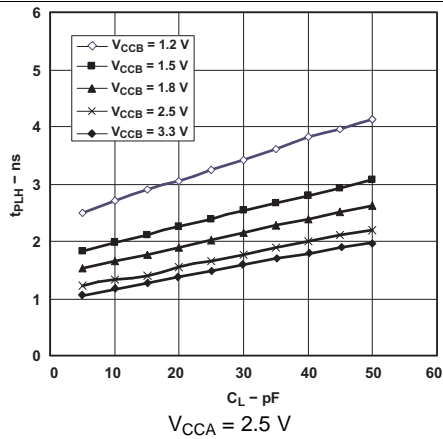

Figure 7. Typical Propagation Delay (A to B) vs Load Capacitance

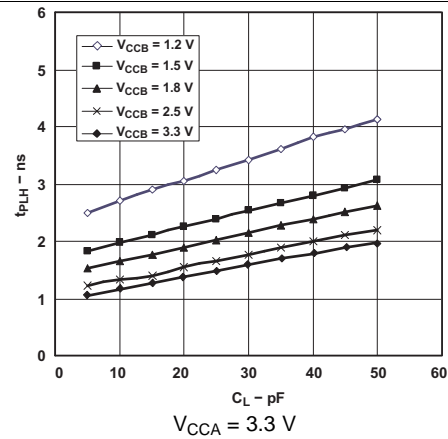

Figure 8. Typical Propagation Delay (A to B) vs Load Capacitance

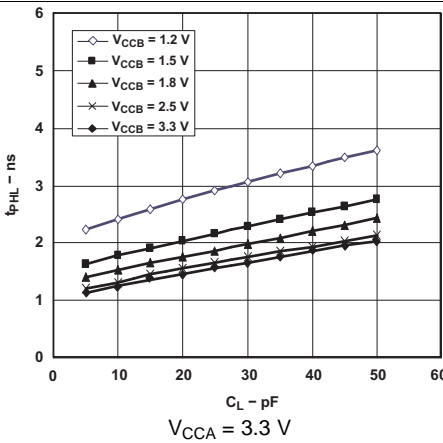

Figure 9. Typical Propagation Delay (A to B) vs Load Capacitance

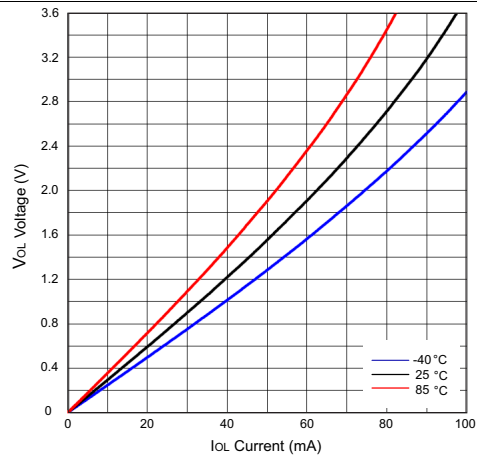

Figure 10. Low-Level Output Voltage (VOL) vs Low-Level Current (IOL)

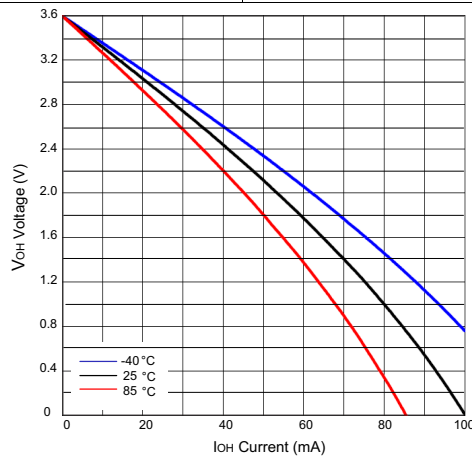
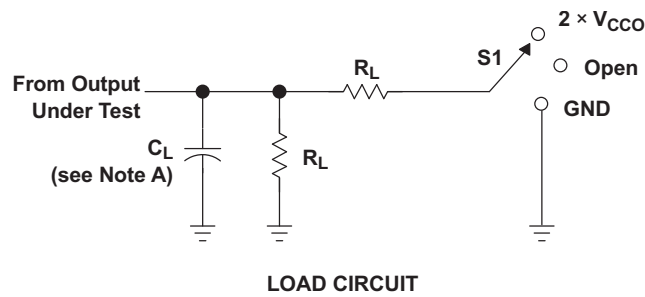

Figure 11. High-Level Output Voltage (VOH) vs High-Level Current (IOH)

8 Parameter Measurement Information



| TEST | S1 |
|-------------------|--------------------|
| t_{pd} | Open |
| t_{PLZ}/t_{PZL} | $2 \times V_{CCO}$ |
| t_{PHZ}/t_{PZH} | GND |

| V_{CCO} | C_L | R_L | V_{TP} |
|--------------------|-------|--------------|----------|
| 1.2 V | 15 pF | 2 k Ω | 0.1 V |
| 1.5 V \pm 0.1 V | 15 pF | 2 k Ω | 0.1 V |
| 1.8 V \pm 0.15 V | 15 pF | 2 k Ω | 0.15 V |
| 2.5 V \pm 0.2 V | 15 pF | 2 k Ω | 0.15 V |
| 3.3 V \pm 0.3 V | 15 pF | 2 k Ω | 0.3 V |

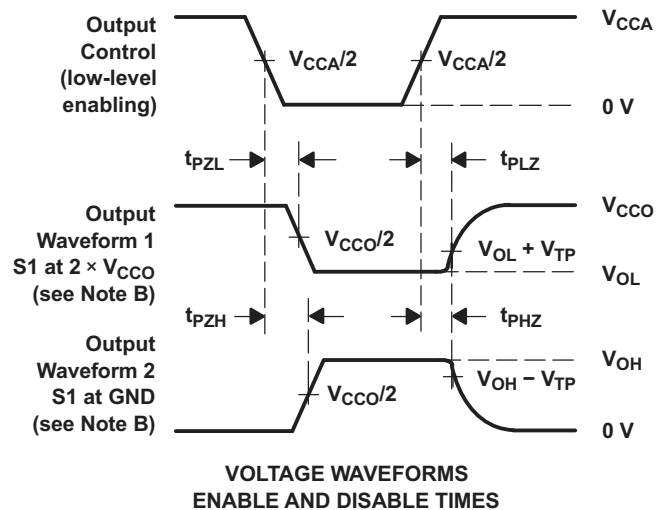
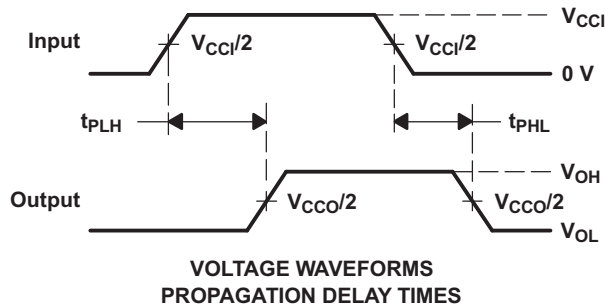
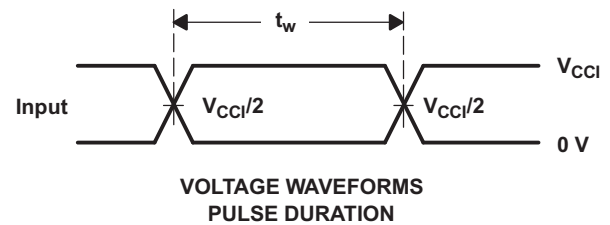

- NOTES:
- C_L includes probe and jig capacitance.
 - Waveform 1 is for an output with internal conditions such that the output is low except when disabled by the output control. Waveform 2 is for an output with internal conditions such that the output is high, except when disabled by the output control.
 - All input pulses are supplied by generators having the following characteristics: PRR \leq 10 MHz, $Z_O = 50 \Omega$, $dv/dt \geq 1$ V/ns.
 - The outputs are measured one at a time, with one transition per measurement.
 - t_{PLZ} and t_{PHZ} are the same as t_{dis} .
 - t_{PZL} and t_{PZH} are the same as t_{en} .
 - t_{PLH} and t_{PHL} are the same as t_{pd} .
 - V_{CC1} is the V_{CC} associated with the input port.
 - V_{CCO} is the V_{CC} associated with the output port.

Figure 12. Load Circuit and Voltage Waveforms

9 Detailed Description

9.1 Overview

The SN74AVC8T245-Q1 is an 8-bit, dual-supply noninverting bidirectional voltage level translation device. Ax pins and control pins (DIR and \overline{OE}) are supported by V_{CCA} , and Bx pins are supported by V_{CCB} . The A port is able to accept I/O voltages ranging from 1.2 V to 3.6 V, while the B port can accept I/O voltages from 1.2 V to 3.6 V. A high on DIR allows data transmission from Ax to Bx and a low on DIR allows data transmission from Bx to Ax when \overline{OE} is set to low. When \overline{OE} is set to high, both Ax and Bx pins are in the high-impedance state.

9.2 Functional Block Diagram

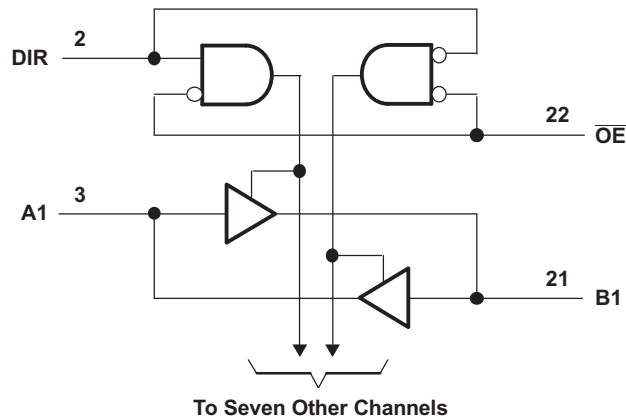

Figure 13. Logic Diagram (Positive Logic)

9.3 Feature Description

9.3.1 Fully Configurable Dual-Rail Design

Both V_{CCA} and V_{CCB} can be supplied at any voltage between 1.2 V and 3.6 V; thus, making the device suitable for translating between any of the low voltage nodes (1.2 V, 1.8 V, 2.5 V, and 3.3 V).

9.3.2 Supports High Speed Translation

The SN74AVC8T245-Q1 device can support high data rate applications. The translated signal data rate can be up to 380 Mbps when the signal is translated from 1.8 V to 3.3 V.

9.3.3 I_{off} Supports Partial-Power-Down Mode Operation

I_{off} prevents backflow current by disabling I/O output circuits when the device is in partial-power-down mode.

9.4 Device Functional Modes

Table 2 lists the functional modes of the device.

**Table 2. FUNCTION TABLE
(Each 8-Bit Section)**

| INPUTS | | OPERATION |
|-----------------|-----|------------------|
| \overline{OE} | DIR | |
| L | L | B data to A bus |
| L | H | A data to B bus |
| H | X | All outputs Hi-Z |

10 Application and Implementation

NOTE

Information in the following applications sections is not part of the TI component specification, and TI does not warrant its accuracy or completeness. TI's customers are responsible for determining suitability of components for their purposes. Customers should validate and test their design implementation to confirm system functionality.

10.1 Application Information

The SN74AVC8T245-Q1 device can be used in level-translation applications for interfacing devices or systems operating at different interface voltages with one another. The SN74AVC8T245-Q1 device is ideal for use in applications where a push-pull driver is connected to the data I/Os. The maximum data rate can be up to 320 Mbps when the device translates a signal from 1.8 V to 3.3 V.

10.2 Typical Application

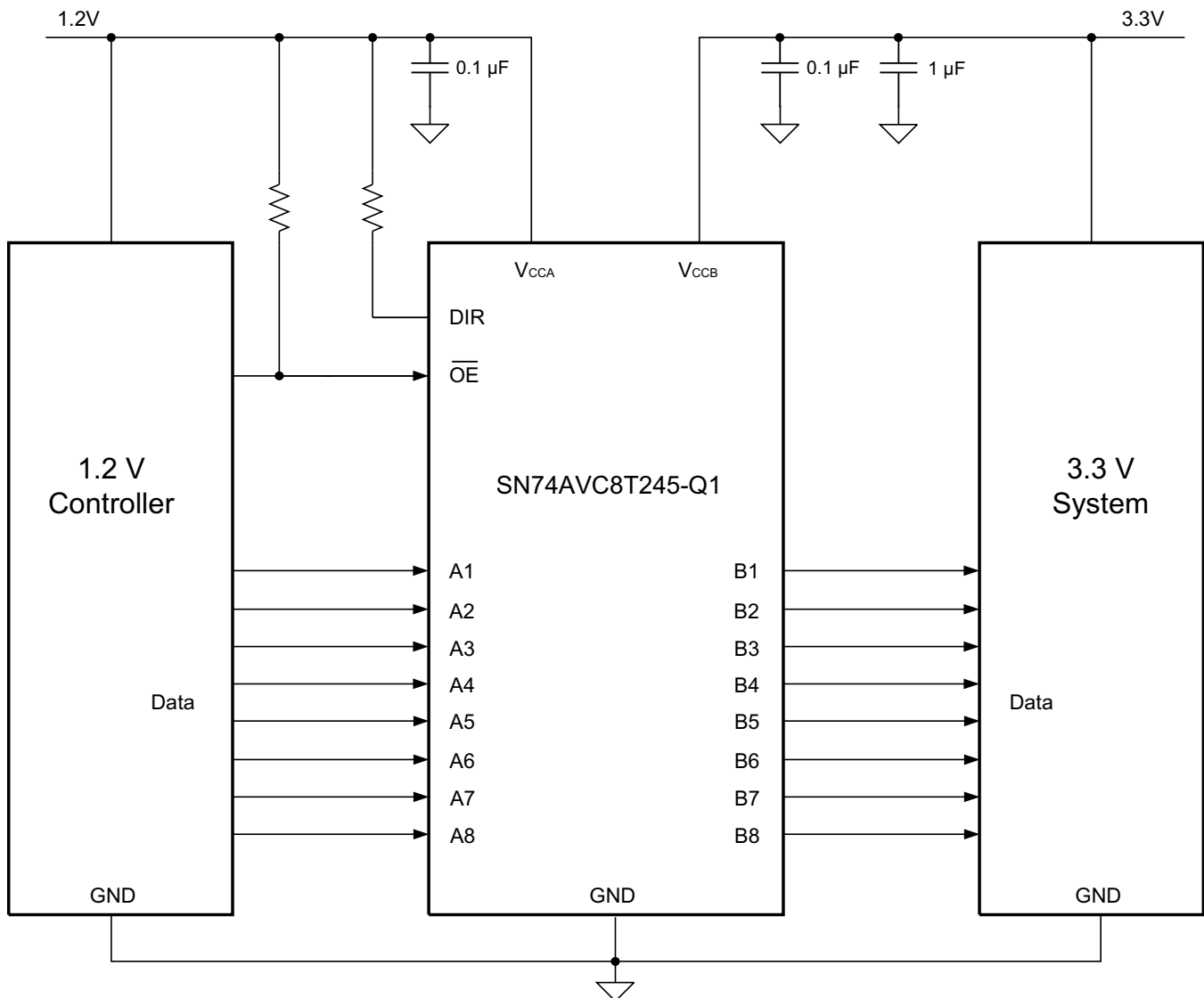

Figure 14. Typical Application Diagram

Typical Application (continued)

10.2.1 Design Requirements

Table 3 lists the parameters for this design example.

Table 3. Design Parameters

| DESIGN PARAMETER | EXAMPLE VALUE |
|----------------------|---------------|
| Input voltage range | 1.2 V |
| Output voltage range | 3.3 V |

10.2.2 Detailed Design Procedure

To begin the design process, determine the following:

- Input voltage range
 - Use the supply voltage of the device that is driving the SN74AVC8T245-Q1 device to determine the input voltage range. For a valid logic high, the value must exceed the V_{IH} of the input port. For a valid logic low, the value must be less than the V_{IL} of the input port. For this example, the input voltage is 1.2 V.
- Output voltage range
 - Use the supply voltage of the device that the SN74AVC8T245-Q1 device is driving to determine the output voltage range. For this example, the output voltage is 3.3 V.

10.2.3 Application Curve

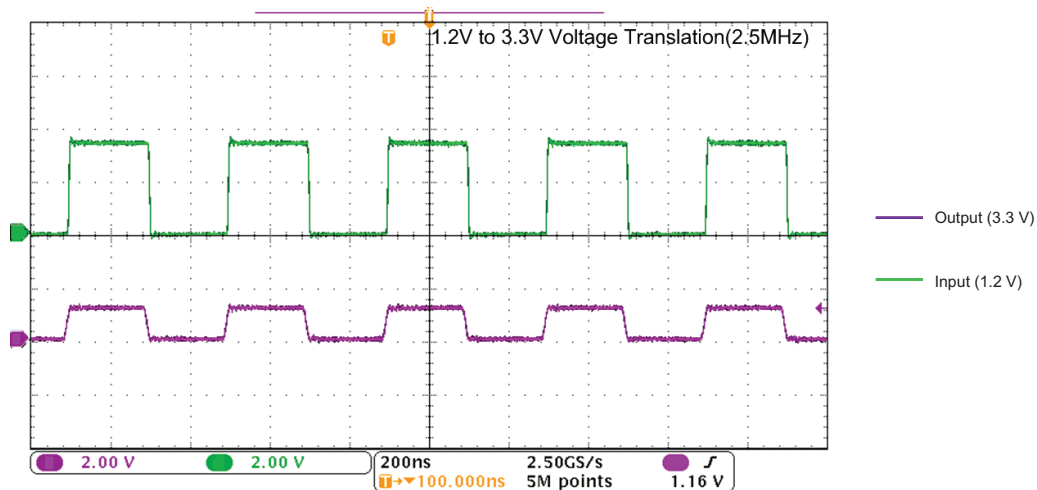

Figure 15. Translation Up (1.2 V to 3.3 V) at 2.5 MHz

11 Power Supply Recommendations

The SN74AVC8T245-Q1 device uses two separate configurable power-supply rails: V_{CCA} and V_{CCB} . V_{CCA} accepts any supply voltage from 1.2 V to 3.6 V, and V_{CCB} accepts any supply voltage from 1.2 V to 3.6 V. The A port and B port are designed to track V_{CCA} and V_{CCB} respectively, allowing for low-voltage bidirectional translation between any of the 1.2-V, 1.5-V, 1.8-V, 2.5-V, and 3.3-V voltage nodes.

The output-enable (\overline{OE}) input circuit is designed so that it is supplied by V_{CCA} ; when the \overline{OE} input is high, all outputs are placed in the high-impedance state. To ensure the high-impedance state of the outputs during power up or power down, the \overline{OE} input pin must be tied to V_{CCA} through a pullup resistor and must not be enabled until V_{CCA} and V_{CCB} are fully ramped and stable. The minimum value of the pullup resistor to V_{CCA} is determined by the current-sinking capability of the driver.

12 Layout

12.1 Layout Guidelines

To ensure reliability of the device, following common printed-circuit board layout guidelines is recommended.

- Bypass capacitors should be used on power supplies.
- Short trace lengths should be used to avoid excessive loading.
- Place pads on the signal paths for loading capacitors or pullup resistors to help adjust rise and fall times of signals, depending on the system requirements.

12.2 Layout Example

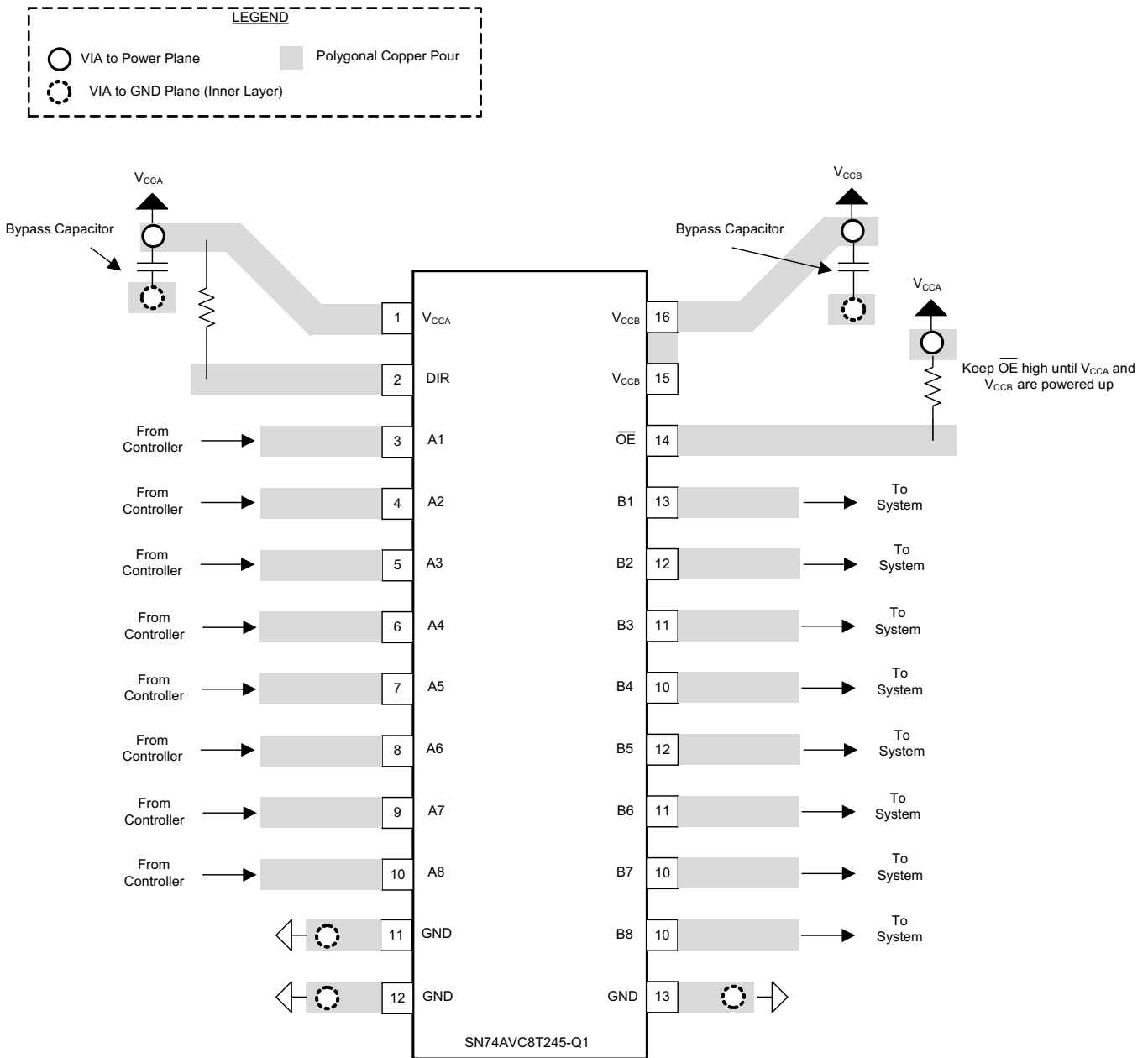

Figure 16. SN74AVC8T245-Q1 Layout Diagram

13 Device and Documentation Support

13.1 Documentation Support

13.1.1 Related Documentation

For related documentation see the following:

- Texas Instruments, [Implications of Slow or Floating CMOS Inputs Application Note](#)
- Texas Instruments, [Understanding and Interpreting Standard-Logic Data Sheets Application Note](#)
- Texas Instruments, [Introduction to Logic Application Note](#)
- Texas Instruments, [Voltage Translation Between 3.3-V, 2.5-V, 1.8-V, and 1.5-V Logic Standards Application Note](#)
- Texas Instruments, [AVC Advanced Very-Low-Voltage CMOS Logic Data Book User's Guide](#)

13.2 Receiving Notification of Documentation Updates

To receive notification of documentation updates, navigate to the device product folder on ti.com. In the upper right corner, click on *Alert me* to register and receive a weekly digest of any product information that has changed. For change details, review the revision history included in any revised document.

13.3 Community Resources

The following links connect to TI community resources. Linked contents are provided "AS IS" by the respective contributors. They do not constitute TI specifications and do not necessarily reflect TI's views; see TI's [Terms of Use](#).

TI E2E™ Online Community *TI's Engineer-to-Engineer (E2E) Community*. Created to foster collaboration among engineers. At e2e.ti.com, you can ask questions, share knowledge, explore ideas and help solve problems with fellow engineers.

Design Support *TI's Design Support* Quickly find helpful E2E forums along with design support tools and contact information for technical support.

13.4 Trademarks

E2E is a trademark of Texas Instruments.

All other trademarks are the property of their respective owners.

13.5 Electrostatic Discharge Caution



These devices have limited built-in ESD protection. The leads should be shorted together or the device placed in conductive foam during storage or handling to prevent electrostatic damage to the MOS gates.

13.6 Glossary

[SLYZ022](#) — *TI Glossary*.

This glossary lists and explains terms, acronyms, and definitions.

14 Mechanical, Packaging, and Orderable Information

The following pages include mechanical, packaging, and orderable information. This information is the most current data available for the designated devices. This data is subject to change without notice and revision of this document. For browser-based versions of this data sheet, refer to the left-hand navigation.

PACKAGING INFORMATION

| Orderable Device | Status (1) | Package Type | Package Drawing | Pins | Package Qty | Eco Plan (2) | Lead/Ball Finish (6) | MSL Peak Temp (3) | Op Temp (°C) | Device Marking (4/5) | Samples |
|--------------------|---------------|--------------|-----------------|------|-------------|-------------------------|-------------------------|----------------------|--------------|-------------------------|-------------------------|
| CAVC8T245QRHLRQ1 | ACTIVE | VQFN | RHL | 24 | 1000 | Green (RoHS & no Sb/Br) | CU NIPDAU | Level-2-260C-1 YEAR | -40 to 125 | WE245Q | Samples |
| SN74AVC8T245QPWRQ1 | ACTIVE | TSSOP | PW | 24 | 2000 | Green (RoHS & no Sb/Br) | CU NIPDAU | Level-3-260C-168 HR | -40 to 125 | WE245Q | Samples |

(1) The marketing status values are defined as follows:

ACTIVE: Product device recommended for new designs.

LIFEBUY: TI has announced that the device will be discontinued, and a lifetime-buy period is in effect.

NRND: Not recommended for new designs. Device is in production to support existing customers, but TI does not recommend using this part in a new design.

PREVIEW: Device has been announced but is not in production. Samples may or may not be available.

OBSOLETE: TI has discontinued the production of the device.

(2) **RoHS:** TI defines "RoHS" to mean semiconductor products that are compliant with the current EU RoHS requirements for all 10 RoHS substances, including the requirement that RoHS substance do not exceed 0.1% by weight in homogeneous materials. Where designed to be soldered at high temperatures, "RoHS" products are suitable for use in specified lead-free processes. TI may reference these types of products as "Pb-Free".

RoHS Exempt: TI defines "RoHS Exempt" to mean products that contain lead but are compliant with EU RoHS pursuant to a specific EU RoHS exemption.

Green: TI defines "Green" to mean the content of Chlorine (Cl) and Bromine (Br) based flame retardants meet JS709B low halogen requirements of <=1000ppm threshold. Antimony trioxide based flame retardants must also meet the <=1000ppm threshold requirement.

(3) MSL, Peak Temp. - The Moisture Sensitivity Level rating according to the JEDEC industry standard classifications, and peak solder temperature.

(4) There may be additional marking, which relates to the logo, the lot trace code information, or the environmental category on the device.

(5) Multiple Device Markings will be inside parentheses. Only one Device Marking contained in parentheses and separated by a "~" will appear on a device. If a line is indented then it is a continuation of the previous line and the two combined represent the entire Device Marking for that device.

(6) Lead/Ball Finish - Orderable Devices may have multiple material finish options. Finish options are separated by a vertical ruled line. Lead/Ball Finish values may wrap to two lines if the finish value exceeds the maximum column width.

Important Information and Disclaimer:The information provided on this page represents TI's knowledge and belief as of the date that it is provided. TI bases its knowledge and belief on information provided by third parties, and makes no representation or warranty as to the accuracy of such information. Efforts are underway to better integrate information from third parties. TI has taken and continues to take reasonable steps to provide representative and accurate information but may not have conducted destructive testing or chemical analysis on incoming materials and chemicals. TI and TI suppliers consider certain information to be proprietary, and thus CAS numbers and other limited information may not be available for release.

In no event shall TI's liability arising out of such information exceed the total purchase price of the TI part(s) at issue in this document sold by TI to Customer on an annual basis.

OTHER QUALIFIED VERSIONS OF SN74AVC8T245-Q1 :

- Catalog: [SN74AVC8T245](#)

NOTE: Qualified Version Definitions:

- Catalog - TI's standard catalog product

TAPE AND REEL INFORMATION



QUADRANT ASSIGNMENTS FOR PIN 1 ORIENTATION IN TAPE



*All dimensions are nominal

| Device | Package Type | Package Drawing | Pins | SPQ | Reel Diameter (mm) | Reel Width W1 (mm) | A0 (mm) | B0 (mm) | K0 (mm) | P1 (mm) | W (mm) | Pin1 Quadrant |
|--------------------|--------------|-----------------|------|------|--------------------|--------------------|---------|---------|---------|---------|--------|---------------|
| CAVC8T245QRHLRQ1 | VQFN | RHL | 24 | 1000 | 180.0 | 12.4 | 3.8 | 5.8 | 1.2 | 8.0 | 12.0 | Q1 |
| SN74AVC8T245QPWRQ1 | TSSOP | PW | 24 | 2000 | 330.0 | 16.4 | 6.95 | 8.3 | 1.6 | 8.0 | 16.0 | Q1 |

TAPE AND REEL BOX DIMENSIONS

*All dimensions are nominal

| Device | Package Type | Package Drawing | Pins | SPQ | Length (mm) | Width (mm) | Height (mm) |
|--------------------|--------------|-----------------|------|------|-------------|------------|-------------|
| CAVC8T245QRHLRQ1 | VQFN | RHL | 24 | 1000 | 210.0 | 185.0 | 35.0 |
| SN74AVC8T245QPWRQ1 | TSSOP | PW | 24 | 2000 | 367.0 | 367.0 | 38.0 |

PW0024A

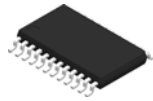

PACKAGE OUTLINE

TSSOP - 1.2 mm max height

SMALL OUTLINE PACKAGE

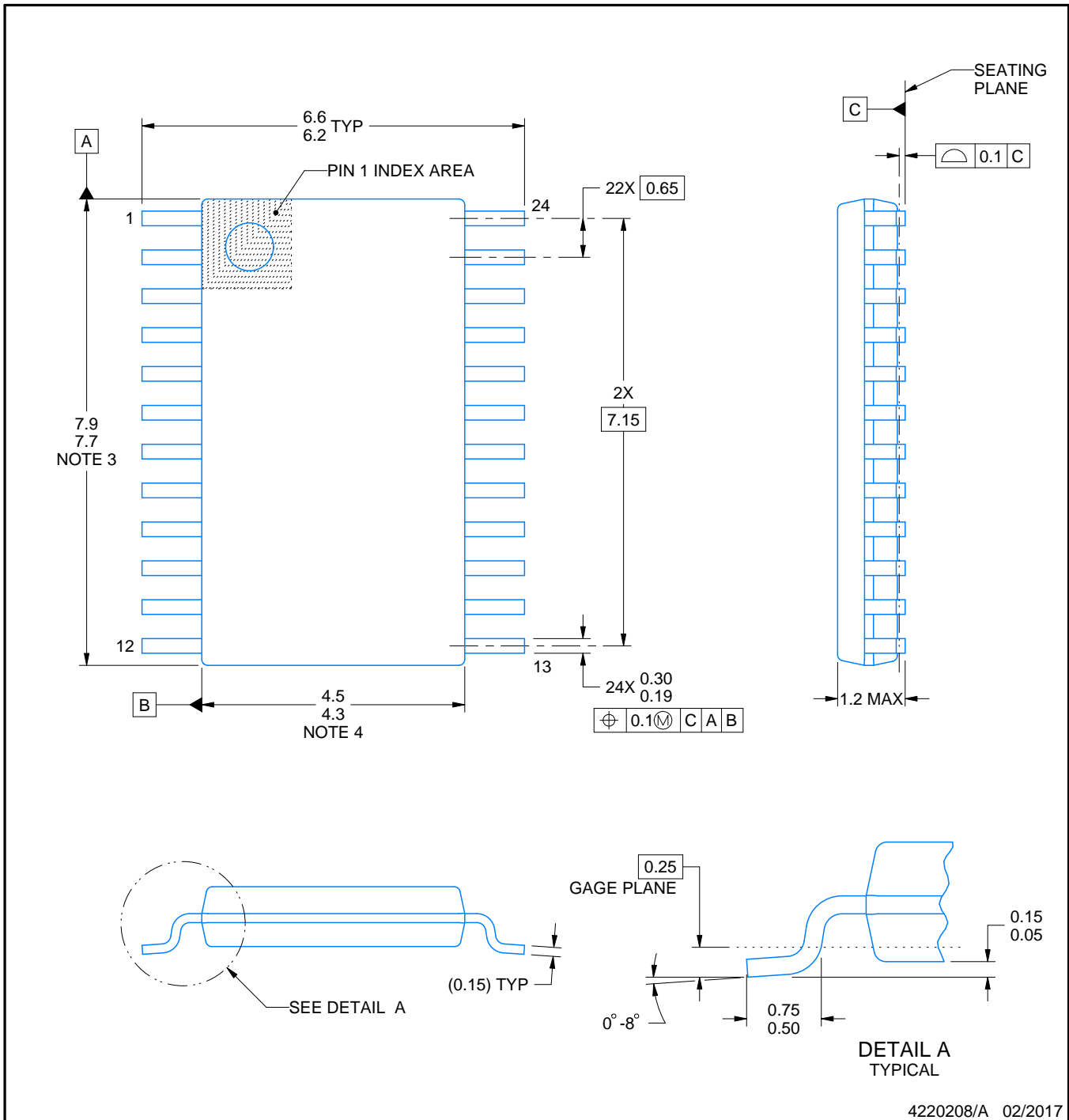

4220208/A 02/2017

NOTES:

1. All linear dimensions are in millimeters. Any dimensions in parenthesis are for reference only. Dimensioning and tolerancing per ASME Y14.5M.
2. This drawing is subject to change without notice.
3. This dimension does not include mold flash, protrusions, or gate burrs. Mold flash, protrusions, or gate burrs shall not exceed 0.15 mm per side.
4. This dimension does not include interlead flash. Interlead flash shall not exceed 0.25 mm per side.
5. Reference JEDEC registration MO-153.

EXAMPLE BOARD LAYOUT

PW0024A

TSSOP - 1.2 mm max height

SMALL OUTLINE PACKAGE

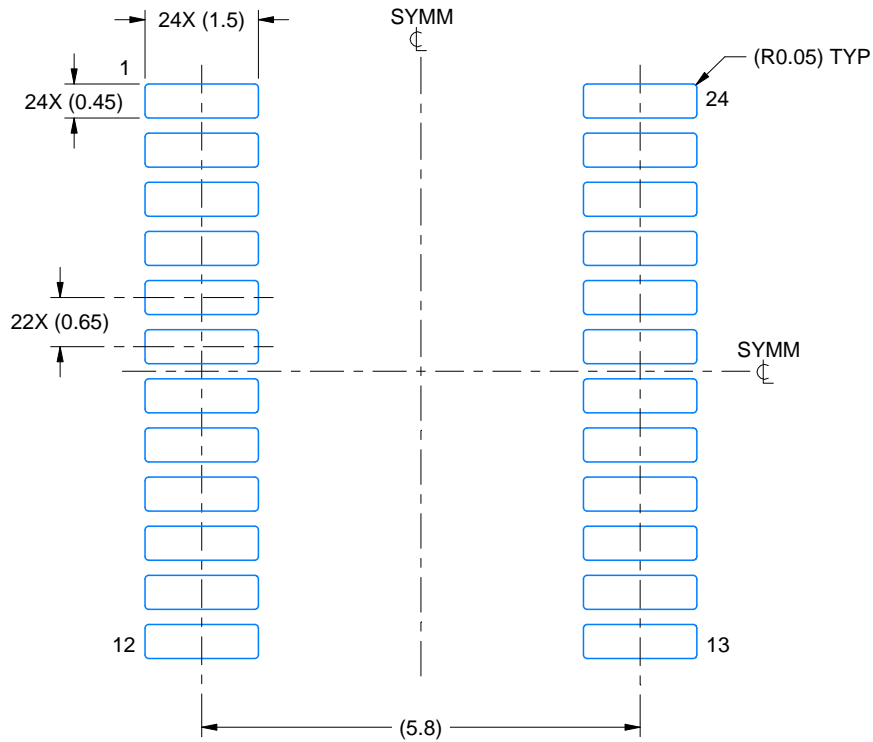

LAND PATTERN EXAMPLE
EXPOSED METAL SHOWN
SCALE: 10X

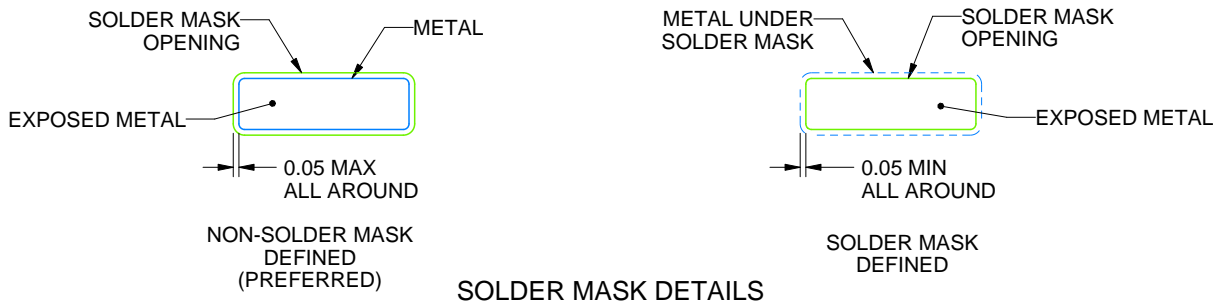

SOLDER MASK DETAILS

4220208/A 02/2017

NOTES: (continued)

- 6. Publication IPC-7351 may have alternate designs.
- 7. Solder mask tolerances between and around signal pads can vary based on board fabrication site.

EXAMPLE STENCIL DESIGN

PW0024A

TSSOP - 1.2 mm max height

SMALL OUTLINE PACKAGE



NOTES: (continued)

8. Laser cutting apertures with trapezoidal walls and rounded corners may offer better paste release. IPC-7525 may have alternate design recommendations.
9. Board assembly site may have different recommendations for stencil design.

MECHANICAL DATA

RHL (R-PVQFN-N24)

PLASTIC QUAD FLATPACK NO-LEAD

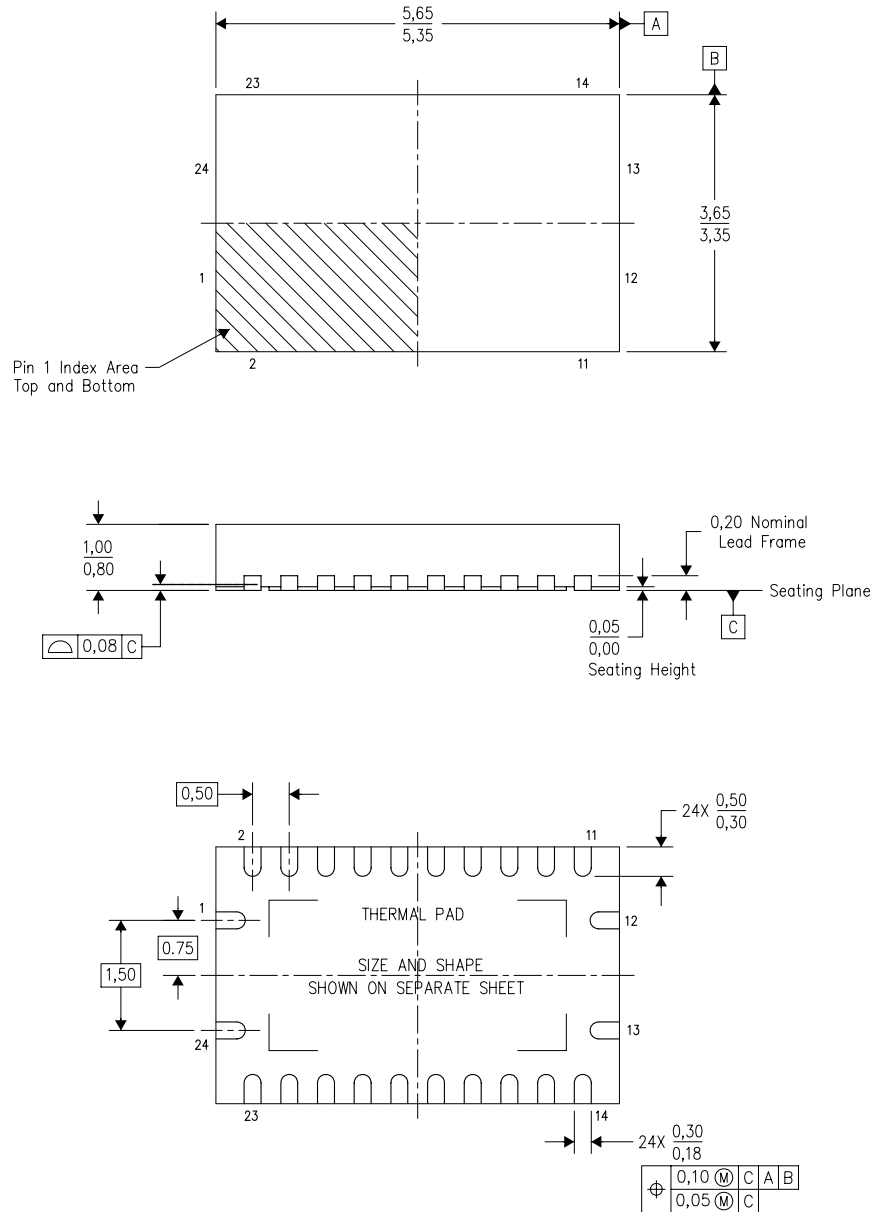

Bottom View

4205346-4/J 12/11

- NOTES:
- All linear dimensions are in millimeters. Dimensioning and tolerancing per ASME Y14.5M-1994.
 - This drawing is subject to change without notice.
 - QFN (Quad Flatpack No-Lead) package configuration.
 - The package thermal pad must be soldered to the board for thermal and mechanical performance.
 - See the additional figure in the Product Data Sheet for details regarding the exposed thermal pad features and dimensions.
 - JEDEC MO-241 package registration pending.

THERMAL PAD MECHANICAL DATA

RHL (S-PVQFN-N24)

PLASTIC QUAD FLATPACK NO-LEAD

THERMAL INFORMATION

This package incorporates an exposed thermal pad that is designed to be attached directly to an external heatsink. The thermal pad must be soldered directly to the printed circuit board (PCB). After soldering, the PCB can be used as a heatsink. In addition, through the use of thermal vias, the thermal pad can be attached directly to the appropriate copper plane shown in the electrical schematic for the device, or alternatively, can be attached to a special heatsink structure designed into the PCB. This design optimizes the heat transfer from the integrated circuit (IC).

For information on the Quad Flatpack No-Lead (QFN) package and its advantages, refer to Application Report, QFN/SON PCB Attachment, Texas Instruments Literature No. SLUA271. This document is available at www.ti.com.

The exposed thermal pad dimensions for this package are shown in the following illustration.

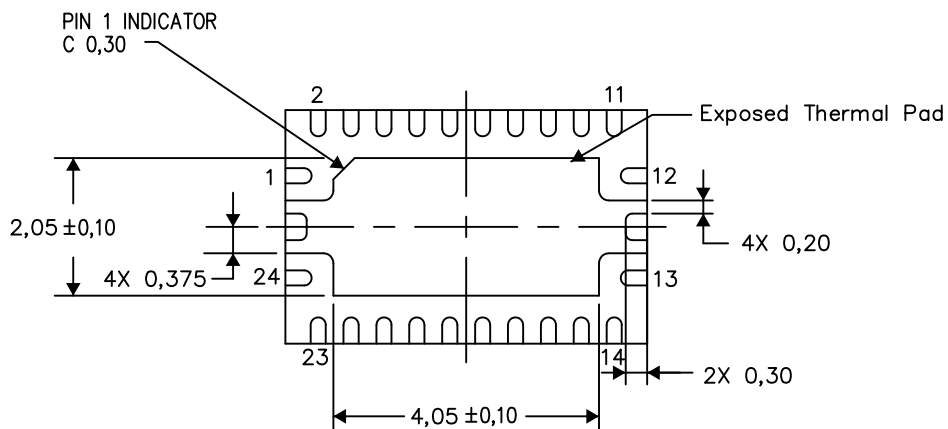

Bottom View

Exposed Thermal Pad Dimensions

4206363-4/N 07/14

NOTE: All linear dimensions are in millimeters

RHL (R-PVQFN-N24)

PLASTIC QUAD FLATPACK NO-LEAD

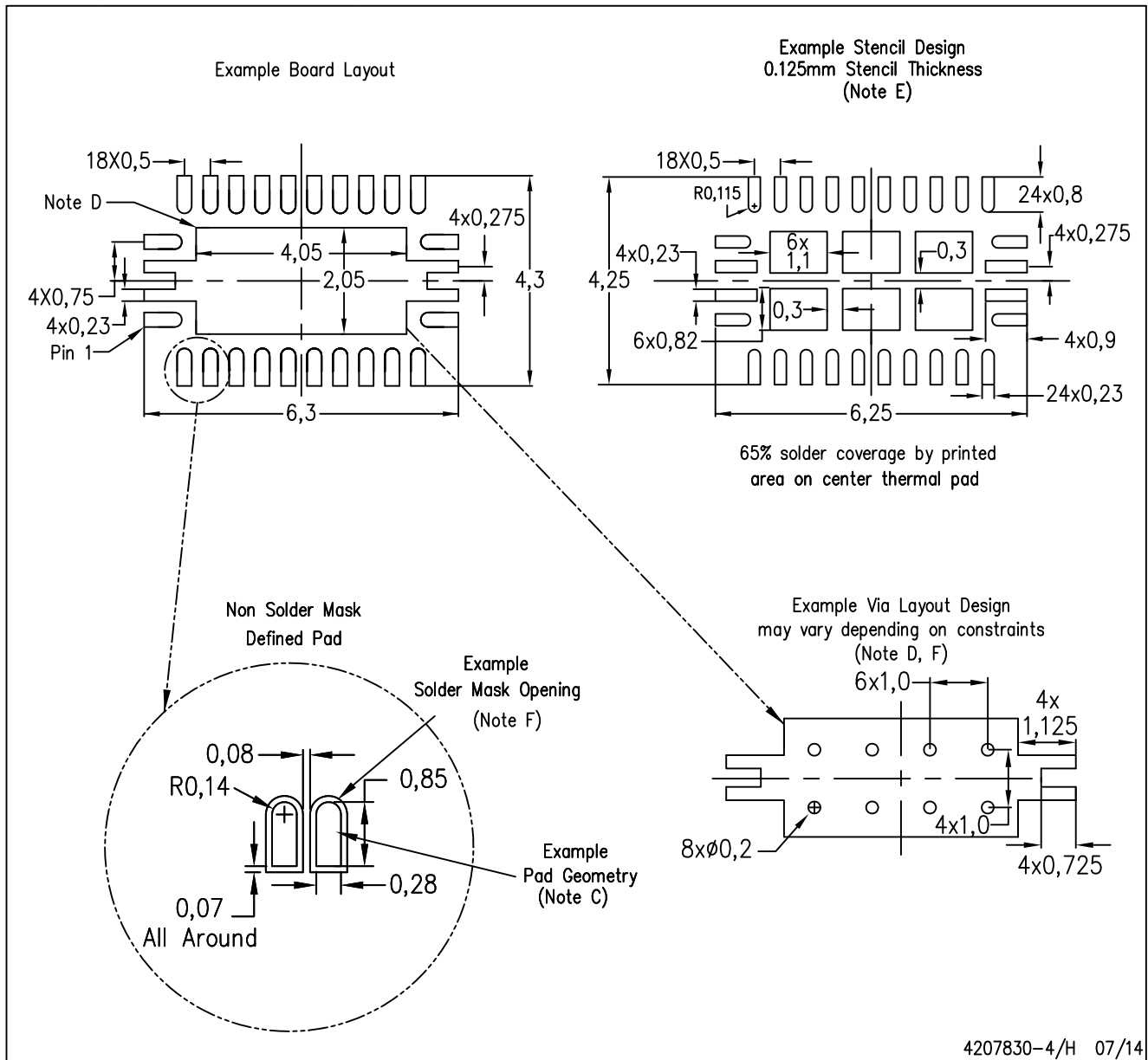

- NOTES:
- A. All linear dimensions are in millimeters.
 - B. This drawing is subject to change without notice.
 - C. Publication IPC-7351 is recommended for alternate designs.
 - D. This package is designed to be soldered to a thermal pad on the board. Refer to Application Note, Quad Flat-Pack Packages, Texas Instruments Literature No. SLUA271, and also the Product Data Sheets for specific thermal information, via requirements, and recommended board layout. These documents are available at www.ti.com <<http://www.ti.com>>.
 - E. Laser cutting apertures with trapezoidal walls and also rounding corners will offer better paste release. Customers should contact their board assembly site for stencil design recommendations. Refer to IPC 7525 for stencil design considerations.
 - F. Customers should contact their board fabrication site for minimum solder mask web tolerances between signal pads.

IMPORTANT NOTICE AND DISCLAIMER

TI PROVIDES TECHNICAL AND RELIABILITY DATA (INCLUDING DATASHEETS), DESIGN RESOURCES (INCLUDING REFERENCE DESIGNS), APPLICATION OR OTHER DESIGN ADVICE, WEB TOOLS, SAFETY INFORMATION, AND OTHER RESOURCES "AS IS" AND WITH ALL FAULTS, AND DISCLAIMS ALL WARRANTIES, EXPRESS AND IMPLIED, INCLUDING WITHOUT LIMITATION ANY IMPLIED WARRANTIES OF MERCHANTABILITY, FITNESS FOR A PARTICULAR PURPOSE OR NON-INFRINGEMENT OF THIRD PARTY INTELLECTUAL PROPERTY RIGHTS.

These resources are intended for skilled developers designing with TI products. You are solely responsible for (1) selecting the appropriate TI products for your application, (2) designing, validating and testing your application, and (3) ensuring your application meets applicable standards, and any other safety, security, or other requirements. These resources are subject to change without notice. TI grants you permission to use these resources only for development of an application that uses the TI products described in the resource. Other reproduction and display of these resources is prohibited. No license is granted to any other TI intellectual property right or to any third party intellectual property right. TI disclaims responsibility for, and you will fully indemnify TI and its representatives against, any claims, damages, costs, losses, and liabilities arising out of your use of these resources.

TI's products are provided subject to TI's Terms of Sale (www.ti.com/legal/termsofsale.html) or other applicable terms available either on ti.com or provided in conjunction with such TI products. TI's provision of these resources does not expand or otherwise alter TI's applicable warranties or warranty disclaimers for TI products.

Mailing Address: Texas Instruments, Post Office Box 655303, Dallas, Texas 75265
Copyright © 2019, Texas Instruments Incorporated

Looking for pricing, stock, or lifecycle information?

Click below to explore more details on WIN SOURCE:

 [View SN74AVC8T245QPWRQ1 on WIN SOURCE](#)

 [Texas Instruments](#) Information

Optimize Your Supply Chain with WIN SOURCE Solutions

-  Global Sourcing Solution
-  Obsolete Management
-  Cost Control Management
-  Shortage Management
-  Alternative Solution
-  Excess Inventory Management