
Features

- Superior FM Strong Signal Behavior by Using an RF AGC
- Soft Mute and HCC for Decreasing Interstation Noise in FM Mode
- Level Indicator (LED Drive) for AM and FM
- DC Mode Control: AM, FM and Tape
- Wide Supply-voltage Range and Low Quiescent Current
- High AF Output Power: 1 W
- Electronic Volume Control
- Electronic AF Bandwidth Control (Treble and High Cut)
- Output Stage for Headphone and Speaker Drive

Benefits

- Excellent AFC Performance (Level Controlled, Both Polarities Available)

Description

The U2510B is an integrated bipolar one-chip AM/FM radio circuit. It contains an FM front-end with preamplifier, FM IF and demodulator, a complete AM receiver, an AF amplifier and a mode switch for AM, FM and tape. This circuit is designed for clock radios and portable radio-cassette recorders.



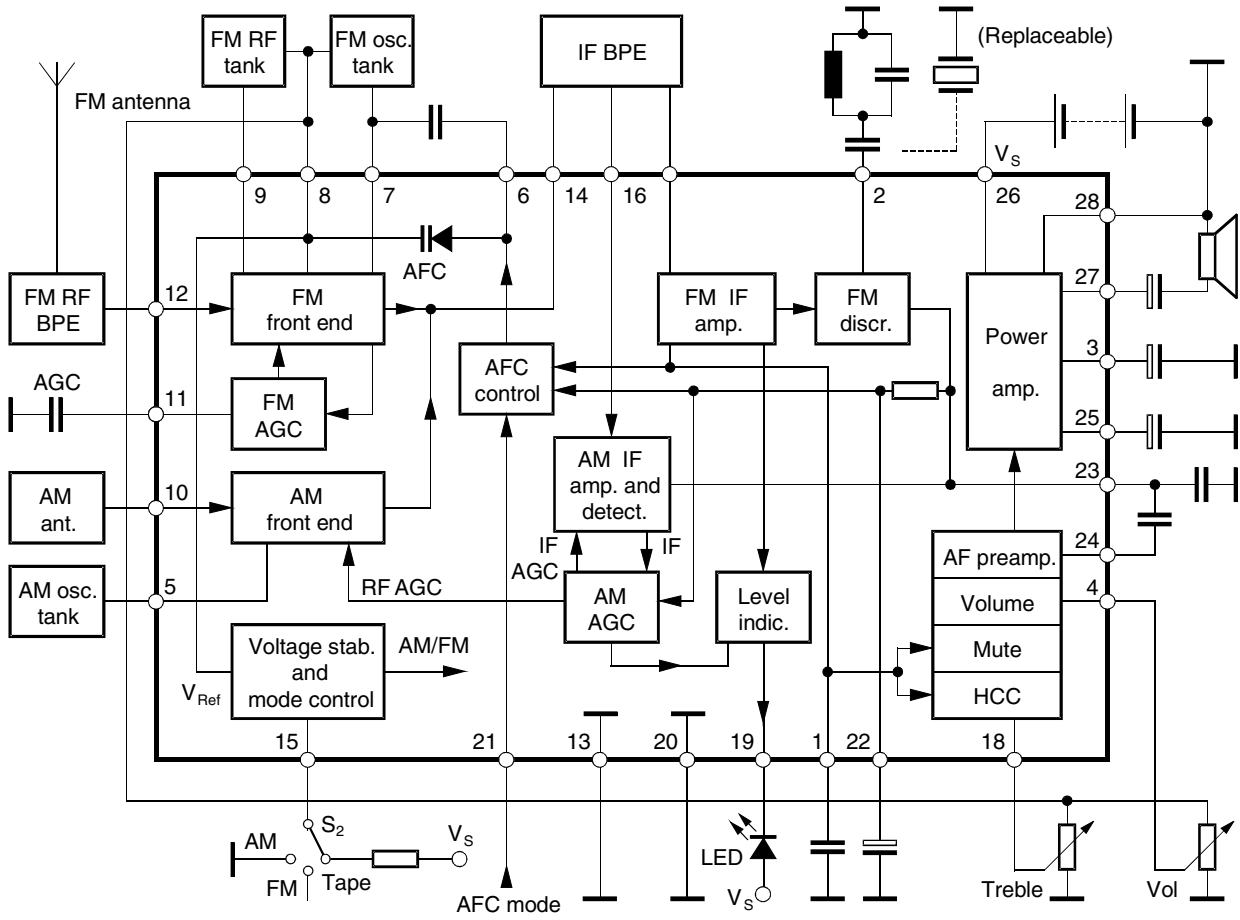
All-band AM/FM Receiver and Audio Amplifier IC

U2510B

Rev. 4759A-AUDR-03/04

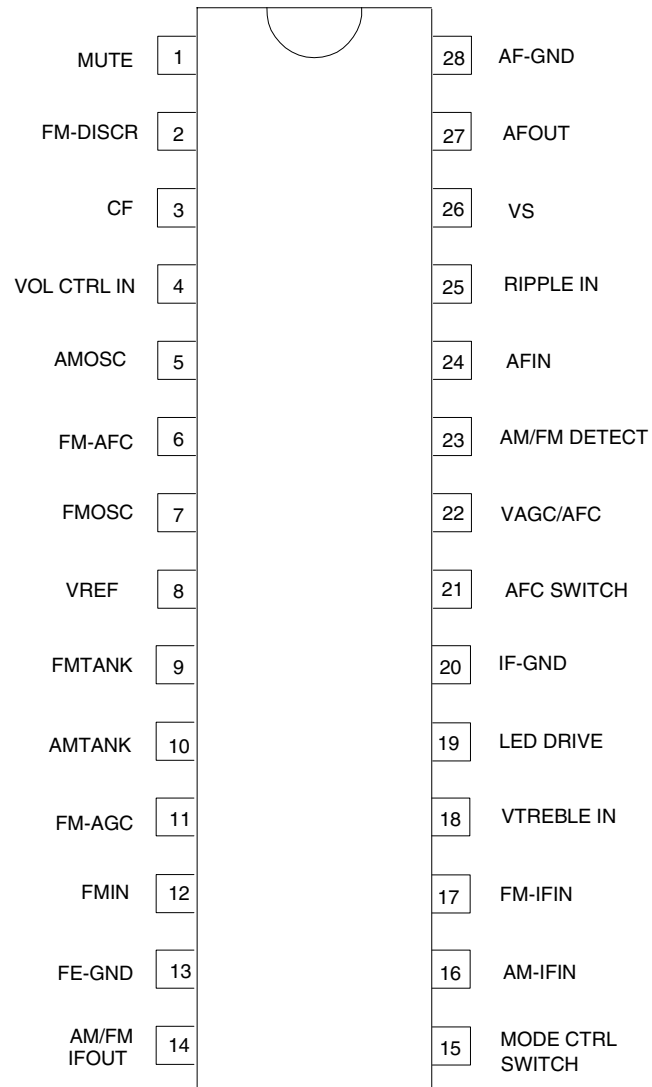


Figure 1. Block Diagram



Pin Configuration

Figure 2. Pinning SDIP28





Pin Description

Pin	Symbol	Function								
1	Mute	Mute voltage output. The time constant (C_{23}), mute depth and threshold are adjustable by load resistance (R_3)								
2	FM-DISCR	FM discriminator filter connection, ceramic resonator or equivalent LC-circuit								
3	CF	Audio negative feedback input. The blocking capacitor (C_8) determines the audio amplifiers low-end cut-off frequency								
4	VOL CTRL IN	Input for volume control voltage								
5	AMOSC	AM oscillator tank circuit input. The recommended load impedance is approximately 2.5 k Ω								
6	FM-AFC	AFC diode connection. The coupling capacitor (C_{19}) determines the AFC characteristic (holding range and slope)								
7	FMOSC	FM oscillator tank circuit input. The recommended load impedance is approximately 3 k Ω								
8	VREF	Regulated voltage output (2.4 V)								
9	FMTANK	FM RF tank circuit connection. The recommended load impedance is approximately 3 k Ω								
10	AMTANK	AM RF tank circuit connection. The recommended load impedance is approximately 20 k Ω								
11	FM-AGC	FM AGC voltage output, time constant (C_{20}). Loading this pin by a resistor (to GND) will increase the FM AGC threshold, grounding this pin will switch off the FM AGC function								
12	FMin	FM RF input (common-base preamplifier transistor). The recommended (RF) source impedance is approximately 100 Ω								
13	FE-GND	FM front-end ground								
14	AM/FM IFOUT	AM/FM IF output (collector output of the IF preamplifier)								
15	MODE CTRL SWITCH	Mode control input: <table border="1" style="margin-left: 20px;"> <thead> <tr> <th>Pin</th> <th>Function</th> </tr> </thead> <tbody> <tr> <td>open</td> <td>FM</td> </tr> <tr> <td>Ground</td> <td>AM</td> </tr> <tr> <td>V_S ($R_4 = 10$ kΩ)</td> <td>Tape</td> </tr> </tbody> </table>	Pin	Function	open	FM	Ground	AM	V_S ($R_4 = 10$ k Ω)	Tape
Pin	Function									
open	FM									
Ground	AM									
V_S ($R_4 = 10$ k Ω)	Tape									
16	AM-IFIN	AM IF input, input impedance = 3.1 k Ω								
17	FM-IFIN	FM IF input, input impedance = 330 Ω								
18	VTREBLE IN	Treble control voltage input								
19	LED DRIVE	Level indicator output (open-collector output, LED drive)								
20	IF-GND	IF ground								
21	AFC SWITCH	AFC function control input: <table border="1" style="margin-left: 20px;"> <thead> <tr> <th>Pin</th> <th>Function</th> </tr> </thead> <tbody> <tr> <td>open</td> <td>AFC off</td> </tr> <tr> <td>Ground</td> <td>$f_{OSC} > f_{in}$</td> </tr> <tr> <td>V_S</td> <td>$f_{OSC} < f_{in}$</td> </tr> </tbody> </table>	Pin	Function	open	AFC off	Ground	$f_{OSC} > f_{in}$	V_S	$f_{OSC} < f_{in}$
Pin	Function									
open	AFC off									
Ground	$f_{OSC} > f_{in}$									
V_S	$f_{OSC} < f_{in}$									
22	VAGC/AFC	AGC/AFC voltage, time constant adjust (C_{10}). The input impedance is approximately 42 k Ω								
23	AM/FM DETECT	AM/FM detector output. The load capacitor (C_{11}) in conjunction with the detector output resistance (7.5 k Ω) determines the (FM) de-emphasis as well as the (modulation) frequency response of the AM detector.								
24	AFIN	Audio amplifier input. The input resistance is approximately 100 k Ω , the coupling capacitor (C_9) determines the low frequency response								
25	RIPPLE IN	Ripple filter connection. The load capacitance (C_{12}) determines the frequency response of the supply-voltage ripple rejection								

Pin Description (Continued)

Pin	Symbol	Function
26	VS	Supply voltage input
27	AFOUT	Audio amplifier output
28	AF-GND	Ground of the audio power stage

Terminal Voltages

Pin	Function	Symbol	Voltage/V					
			V _S = 3 V			V _S = 6 V		
			AM	FM	TAPE	AM	FM	TAPE
1	Mute voltage (R ₃ = 0)	V ₁	-	1.6	-	-	1.6	-
2	FM discriminator	V ₂	-	1.0	-	-	1.0	-
3	Negative feedback	V ₃	1.2	1.2	1.2	2.6	2.6	2.6
4	Volume control input (S ₄ = A)	V ₄	2.4	2.4	2.4	2.4	2.4	2.4
5	AM oscillator	V ₅	2.4	-	-	2.4	-	-
6	FM AFC	V ₆	-	1.9	-	-	1.9	-
7	FM oscillator	V ₇	-	2.4	-	-	2.4	-
8	V _{Ref}	V ₈	2.4	2.4	2.4	2.4	2.4	2.4
9	FM RF tank	V ₉	-	2.4	2.4	-	2.4	-
10	AM input	V ₁₀	2.4	-	-	-	2.4	-
11	FM AGC	V ₁₁	-	0	-	-	0	-
12	FM input	V ₁₂	-	1.4	-	-	1.4	-
13	Front-end ground	V ₁₃	-	-	-	-	-	-
14	AM/FM IF output	V ₁₄	2.9	2.7	-	5.9	5.7	-
15	Mode control switch	V ₁₅	0	-	2.9	0	-	5.7
16	AM IF input	V ₁₆	0	-	-	0	-	-
17	FM IF input	V ₁₇	-	0.7	-	-	0.7	-
18	Treble control input (S ₅ = A)	V ₁₈	2.4	2.4	2.4	2.4	2.4	2.4
19	LED	V ₁₉	-	-	-	-	-	-
20	IF ground	V ₂₀	0	0	0	0	0	0
21	AFC switch (S ₃ = off)	V ₂₁	1.2	1.2	1.2	1.2	1.2	1.2
22	AGC (AM)/AFC (FM)	V ₂₂	1.5	1.2	-	1.5	1.2	-
23	Detector output	V ₂₃	1.5	1.2	-	1.5	1.2	-
24	AF input	V ₂₄	1.5	1.5	1.5	1.5	1.5	1.5
25	Ripple filter	V ₂₅	2.7	2.7	2.7	5.3	5.3	5.3
26	Supply voltage	V ₂₆	3.0	3.0	3.0	6.0	6.0	6.0
27	AF output	V ₂₇	1.2	1.2	1.2	2.6	2.6	2.6
28	AF ground	V ₂₈	0	0	0	0	0	0



Absolute Maximum Ratings

Stresses beyond those listed under “Absolute Maximum Ratings” may cause permanent damage to the device. This is a stress rating only and functional operation of the device at these or any other conditions beyond those indicated in the operational sections of this specification is not implied. Exposure to absolute maximum rating conditions for extended periods may affect device reliability.

Parameters	Symbol	Value	Unit
Supply voltage	V_S	13	V
Power dissipation	P_{tot}	900	mW
Ambient temperature range	T_{amb}	-20 to +75	°C

Electrical Characteristics

$V_S = 6\text{ V}$, $T_{amb} = 25^\circ\text{C}$, “Test Circuit” on page 12, unless otherwise specified

Parameters	Test Conditions	Pin	Symbol	Min.	Typ.	Max.	Unit
Supply voltage range			V_S	2.5		9 ⁽¹⁾	V
Oscillator stop voltage			V_S	2.2			V
Operating temperature range			T	-20		+75	°C
Supply quiescent current	$V_{i1} = V_{i2} = V_4 = 0$; AM ($S_2 = \text{AM}$) FM ($S_2 = \text{FM}$) TAPE ($S_2 = \text{Tape}$)		I_S I_S I_S		4.0 6.5 2.2		mA mA mA
Regulated voltage		8	V_{Ref}		2.4		V
Audio Amplifier V_{i3} (pin 24), test point: V_o (pin 27) $f = 1\text{ kHz}$ AF measuring range: 30 Hz to 20 kHz, $S_2 = \text{Tape}$, $S_4 = \text{A}$, $S_5 = \text{A}$							
Input resistance		24	R_j		100		k Ω
Closed loop voltage gain	$GV_{af1} = 20 \log (V_o/V_{i3})$ $V_{i3} = 10\text{ mV}$		GV_{af1}		40		dB
Output voltage	$V_{i3} = 100\text{ mV}$, $S_4 = \text{B}$		V_o		0.7	3	mV
High-end cut-off frequency	f_c (-3 dB) $S_5 = \text{B}$		f_c f_c		13 0.8		kHz kHz
Supply-voltage rejection ratio	$SVRR = 20 \log (V_{hum}/V_o)$ $V_{hum} = 200\text{ mV}$, $f_{hum} = 200\text{ Hz}$, $S_4 = \text{B}$		SVRR		32		dB
Noise voltage	$S_4 = \text{B}$, $V_{i3} = 0$		V_n		300	1000	μV
AF output power	THD = 10%, $R_L = 8\ \Omega$ $V_S = 4.5\text{ V}$ $V_S = 6.0\text{ V}$ $V_S = 9.0\text{ V}$		P_o P_o P_o	400	225 420 1000		mW mW mW
Distortion	$P_o = 50\text{ mW}$, $R_L = 8\ \Omega$		d		0.6		%
FM Section , $V_{i2} = 60\text{ dB}\mu\text{V}$, $f_{i2} = 98\text{ MHz}$, $f_m = 1\text{ kHz}$, deviation = $\pm 22.5\text{ kHz}$, $f_{iIF} = 10.7\text{ MHz}$, AF measuring range: 300 Hz to 20 kHz, $S_2 = \text{FM}$, $S_1 = \text{A}$, $S_6 = \text{B}$, test point: V_D (pin 23)							
FM front-end voltage gain	$GV_{FM} = 20 \log (V_{iIF}/V_{i2})$ $S_1 = \text{B}$, $V_{i2} = 40\text{ dB}\mu\text{V}$		GV_{FM}		30		dB
Recovered audio voltage		23	VD_{af}		85		mV
Detector output resistance		23	R_{Do}		7.5		k Ω

Note: 1. U2510B-M_T: maximum 6 V

Electrical Characteristics (Continued)

$V_S = 6\text{ V}$, $T_{amb} = 25^\circ\text{C}$, "Test Circuit" on page 12, unless otherwise specified

Parameters	Test Conditions	Pin	Symbol	Min.	Typ.	Max.	Unit
Detector output distortion	dev. = $\pm 75\text{ kHz}$		THD		0.5		%
	$V_{i2} = 60\text{ dB}\mu\text{V}$ $V_{i2} = 105\text{ dB}\mu\text{V}$		THD		0.8		%
AM rejection ratio	$m = 30\%$		AM_{RR}		25		dB
RF sensitivity	$(S+N)/N = 26\text{ dB}$		V_{i2}		9		$\text{dB}\mu\text{V}$
	$(S+N)/N = 46\text{ dB}$		V_{i2}		22		$\text{dB}\mu\text{V}$
Limiting threshold (-3 dB)			V_{i2}		3		$\text{dB}\mu\text{V}$
Mute voltage	Test point: Mute		V_{mute}		1.8		V
	$V_{i2} = 0$ $V_{i2} = 60\text{ dB}\mu\text{V}$		V_{mute}		0.4		V
Mute depth	Referred to V_0 at $V_{i2} = 0$		MD		26		dB
	$S_6 = A$ $S_6 = C$		MD		20		dB
AFC holding range	$f_{OSC} > f_{in}$, $S_3 = A$, $S_6 = A$		FHR		no AFC		
	$V_{i2} \leq 10\text{ dB}\mu\text{V}$		FHR		± 180		kHz
	$V_{i2} = 20\text{ dB}\mu\text{V}$ $V_{i2} = 80\text{ dB}\mu\text{V}$		FHR		± 220		kHz
LED current			I_{LED}		5.5		mA
Oscillator voltage	$eZ_{load} = 2.5\text{ k}\Omega$	7	V_{OSC}		180		mV
AM Section $V_{i1} = 60\text{ dB}\mu\text{V}$, $f_{i1} = 1.6\text{ MHz}$, $f_m = 1\text{ kHz}$, $m = 30\%$, $f_{iIF} = 455\text{ kHz}$, AF measuring range: 300 Hz to 20 kHz, ($S_2 = AM$, $S_1 = B$, test point: V_D)							
AM front-end voltage gain	$GV_{AM} = 20 \log(V_{iIF}/V_{i1})$ $V_{i1} = 20\text{ dB}\mu\text{V}$, $S_1 = A$		GV_{AM}		25		dB
Recovered audio voltage			V_{Daf1}		70		mV
Detector output resistance		23	R_{Do}		7.5		$\text{k}\Omega$
Detector output distortion	$V_{i1} = 60\text{ dB}\mu\text{V}$		THD		1		%
	$V_{i1} = 105\text{ dB}\mu\text{V}$		THD		3		%
RF sensitivity	$(S+N)/N = 10\text{ dB}$		V_{i1}		0		$\text{dB}\mu\text{V}$
	$(S+N)/N = 26\text{ dB}$		V_{i1}		16		$\text{dB}\mu\text{V}$
	$(S+N)/N = 46\text{ dB}$		V_{i1}		35		$\text{dB}\mu\text{V}$
AGC figure of merit referred to V_{Daf}	$V_{i1} = 105\text{ dB}\mu\text{V}$, voltage drop (V_{Daf}) = -10 dB		FOM		100		dB
IF input resistance		16	Z_i		3.1		$\text{k}\Omega$
LED current			I_{LED}		5.5		mA
Oscillator voltage		5	V_{OSC}		160		mV

Note: 1. U2510B-M_T: maximum 6 V

Figure 3. Quiescent Current

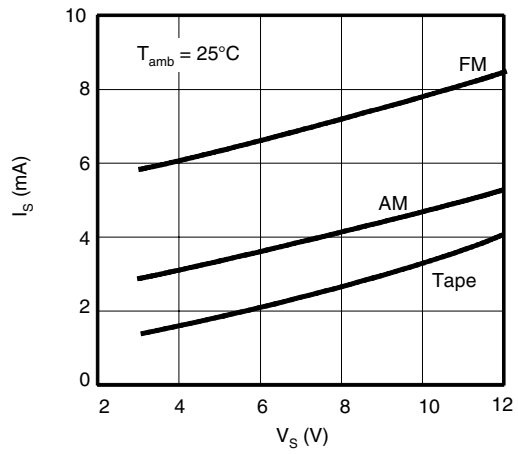


Figure 4. AF Section

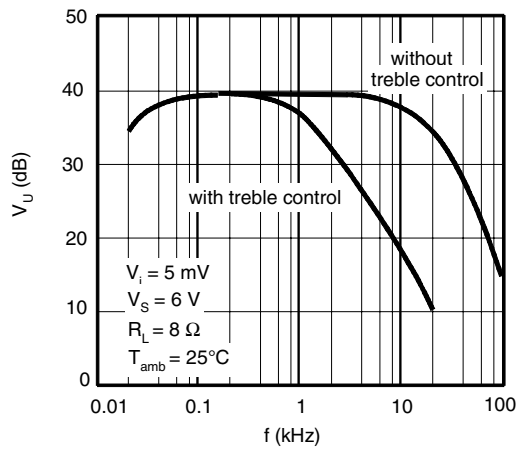


Figure 5. AF Section: Distortion

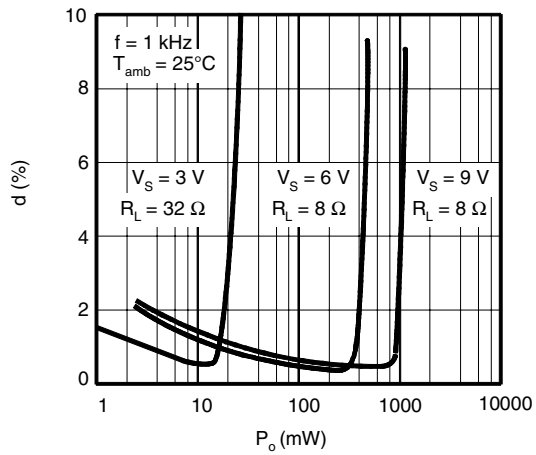


Figure 6. AF Section: Maximum Output Power

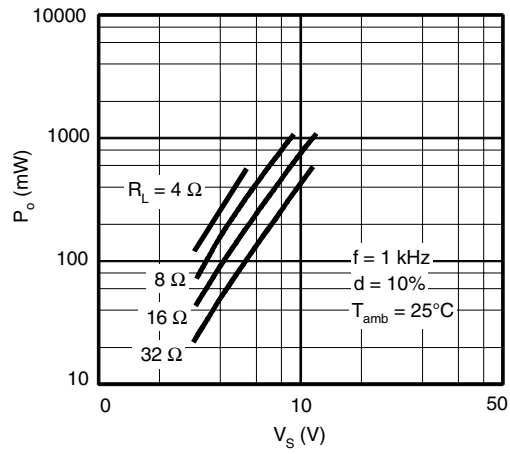


Figure 7. AF Section: Supply-voltage Rejection Ratio

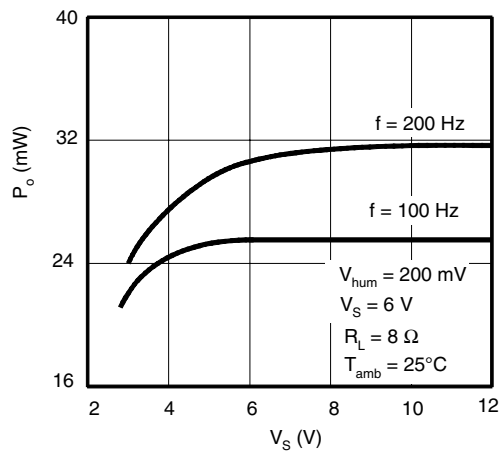


Figure 8. FM Section: Mute Voltage

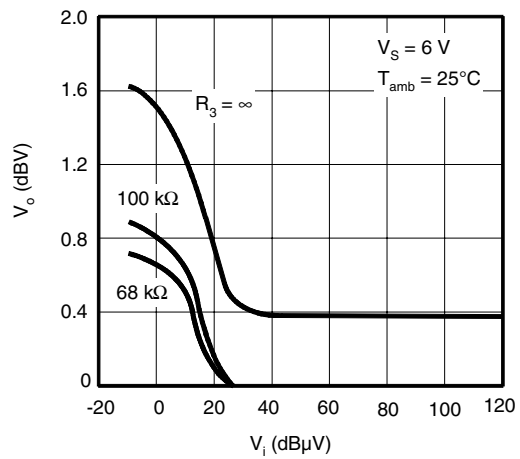


Figure 9. AM Section: Demodulator Output Level

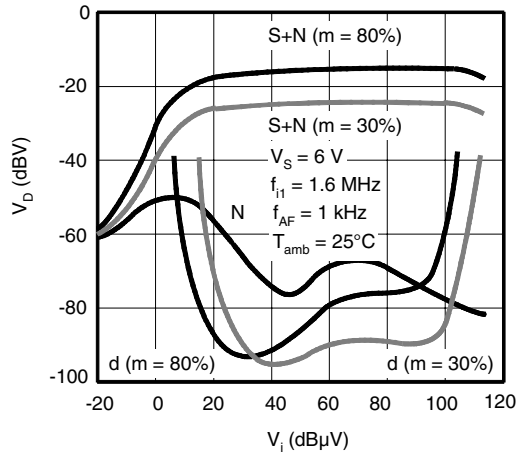


Figure 10. Volume Control Range Characteristics

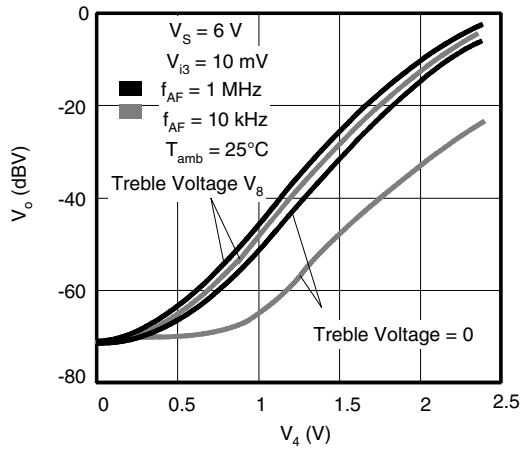


Figure 11. AM/FM Level Indicator Current

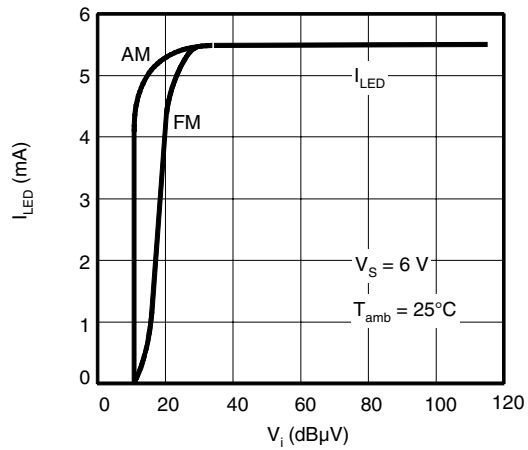


Figure 12. AM Section: AGC Voltage (at Pin 22)

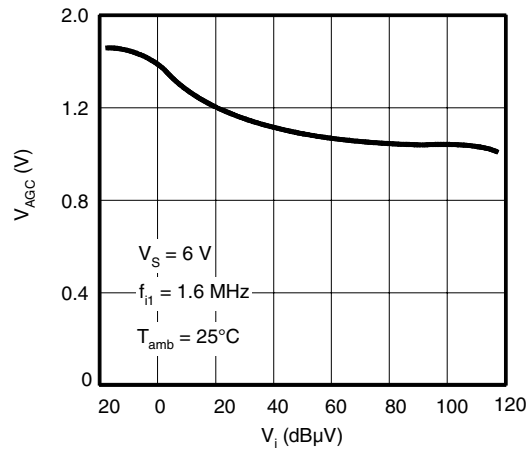


Figure 13. FM Section: Demodulator Output Level

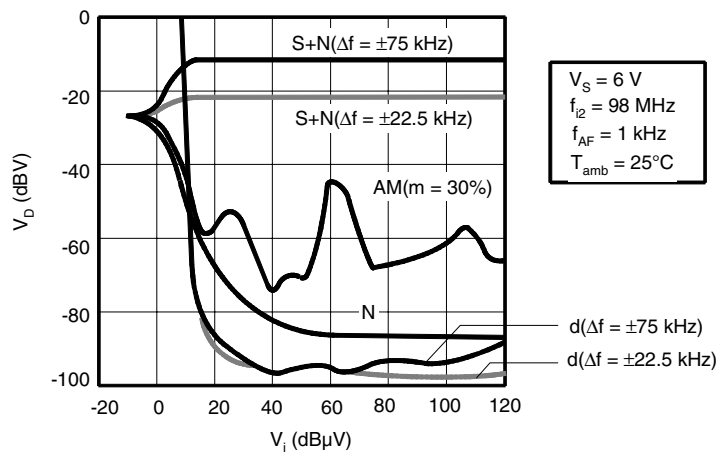


Figure 14. FM Section: Audio Output Level

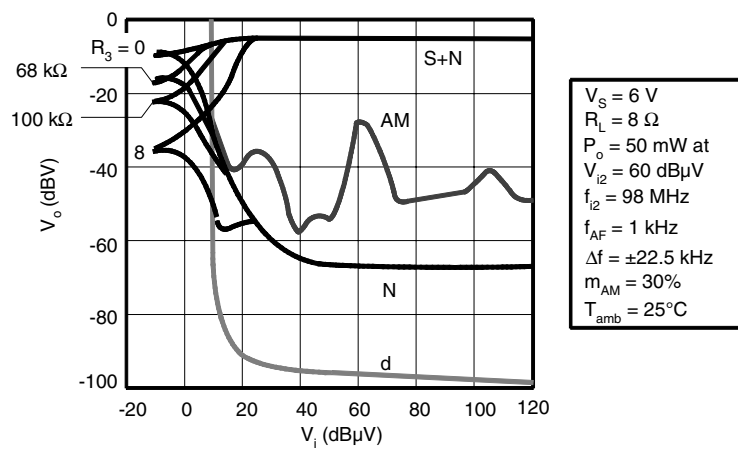


Figure 15. AM Section: Audio Output Level

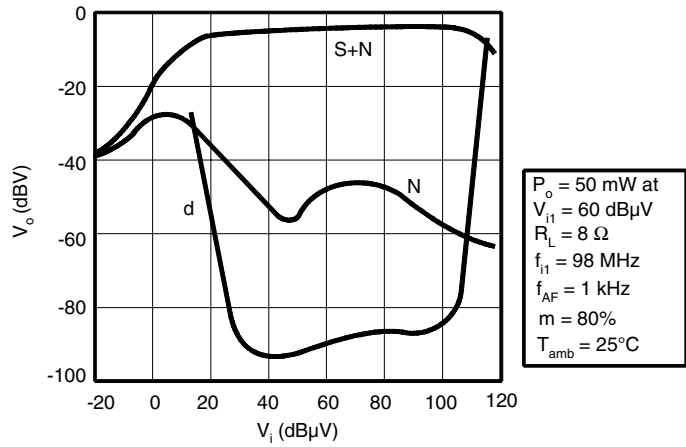
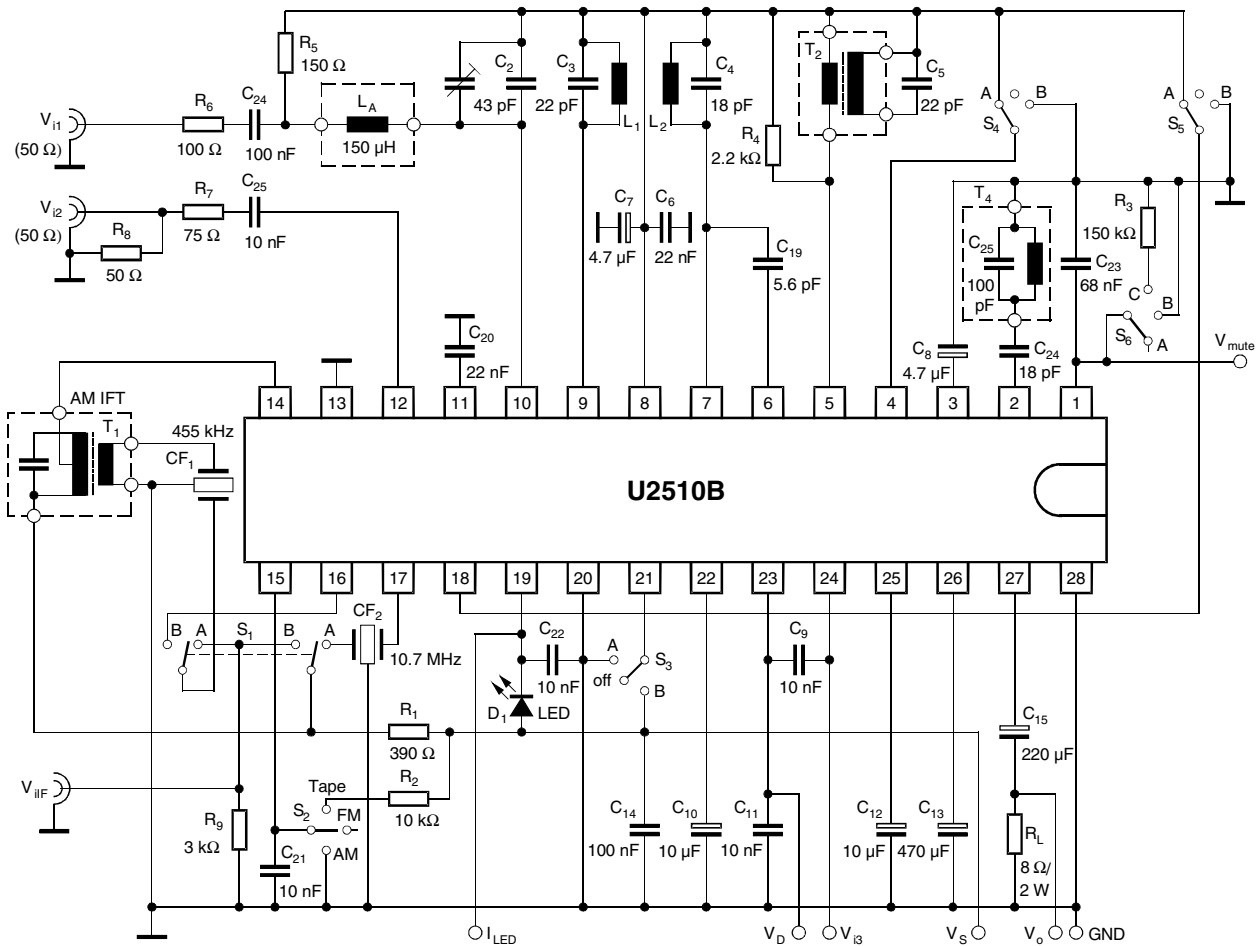


Figure 16. Test Circuit



Application

General

The U2510B is a bipolar monolithic IC for use in radio sets such as headphone receivers, radio recorders and clock radios. The IC contains all AM, FM, AF and switching function blocks necessary to design these kinds of radio receivers using only few components around the IC. In the design, special efforts were made to get good performance for all AM bands (short and long wave).

The implementation of enhanced functions (options) makes it possible to improve the radio's performance and to produce radios with interesting features. In this case few (external) parts have to be changed or added. By using all or some of the options offered by the U2510B different types or classes of radios can be designed to the customer's requirements with the same IC.

One of the main advantages of the U2510B is that all receiver functions (including the options) are integrated and tested on a system level. This allows cost savings due to:

1. Shorter development time
2. Higher reproductivity and low reject level in the set production line

Another advantage is the wide operating voltage range, especially the upper limit (13 V). This feature allows the use of a soft power supply for line powered radios which can also reduce the set's total cost.

Circuit Example

Figure 17 on page 15 shows a circuit diagram for low-end AM/AF radios using the U2510B. Figure 18 on page 16 shows a circuit diagram of an AM/AF radio for higher class designs using all possible options of the U2510B. The layout of the PC board, shown in Figure 19 on page 16, is suitable for both the circuit example shown in Figure 17 on page 15 and the circuit example shown in Figure 18 on page 16. The associated coil, varicon and filter specifications are listed in the table: "Coil Data and Components" on page 17. The circuit diagram in Figure 18 on page 16, has the following options compared to the circuit diagram in Figure 17 on page 15 (the additional parts, which have to be provided, are listed in parentheses):

- a) Soft mute and high cut control in FM mode (1 capacitor)
- b) Electronic treble control in AM, FM and TAPE mode (1 pot.)
- c) On-chip mode control for TAPE application
- d) RF AGC in FM mode (1 capacitor)
- e) AFC, adjustable to the correct polarity and slope (1 capacitor)
- f) Tuning indication using a LED as an indicator (1 LED, 1 capacitor)

Option a) reduces the interstation noise by the two functions: soft mute and HCC. Both are controlled by the mute voltage (pin 1). The soft mute reduces the loudness only, while the HCC reduces the high-end audio cut-off frequency of the audio preamplifier, when the signal level falls below a given threshold. This signal level threshold as well as the mute depth can be reduced by adding a resistor (R_3) or by increasing the FM front-end gain.

Option b) allows the treble control for all operating modes without the need of an additional capacitor. This concept leads to a smooth and correct treble control behavior which is an improvement compared to the controlled RC network normally used.

Option c) is very useful for applications in radio cassette-recorders, for instance. In TAPE mode, the AM/FM receiver blocks are completely switched off and the signal from the tape recorder can be fed to the audio amplifier's input directly. This saves quiescent current and makes the TAPE switching easy. However, to minimize switching noise by the mode switch, the following switch sequence should be chosen: AM, FM, TAPE.

Option d) improves the strong signal behavior by protecting the FM mixer against overload. This is provided by the integrated broad-band-width RF AGC. If necessary, the AGC threshold can be decreased by a resistor, loading pin 11 to GND (not shown).

Option e) improves the tuning behavior substantially. The special design of the on-chip AFC function means that common disadvantages such as asymmetrical slope, (chip-) temperature effects and unlimited holding range are avoided. As mentioned in the "Pin Description" on page 4, the AFC slope has to be inverted when the local oscillator (LO) frequency has to be below the receiving frequency. This can be achieved by connecting pin 21 to the potential of pin 8. In addition to the options described above, the following proposals are implemented in the circuit diagram (Figure 18 on page 16), too:

- An FM IFT is applied. This improves the channel selectivity and minimizes substantially the spurious responses caused by the FM ceramic filter (CF₂). With the choice of the winding ratio of this IFT, the FM front-end gain can be matched to other values if necessary.
- In the FM RF input section, the low cost antenna filter (L₅, C₁₅) is replaced by a special band-pass filter (PFW8). Such a BPF protects the FM front-end against the out-of-band interference signals (TV channels, etc.) which could disturb the FM reception.

Design Hints

The value of the power supply blocking capacitor C₁₃ should not be below 470 µF. In addition, this capacitor should be placed near pin 26. This will help to avoid unacceptable noise generated by noise-radiation from the audio amplifier via the bar-antenna. In designs where the supply voltage goes below 2.5 V, the value of the blocking capacitor (C₇) should be chosen as 47 µF or even higher. To achieve a high rejection of short wave reception in medium wave operation, the LO amplitude at pin 5 should not exceed approximately 200 mV. This LO amplitude depends on the LO transformer's Q and its turns ratio. For the LO transformer type described in the Table "Coil Data and Components" on page 17, a resistor R₄ (2.2 kΩ for example) in parallel to the secondary side of the AM LO transformer T₂ is recommended. To minimize feedback effects in the RF/IF part in FM mode, the capacitor C₆ should be placed as near to pins 8 and 20 as possible.

As shown in the application circuit diagrams (Figure 17 on page 15 and Figure 18 on page 16), in FM mode ceramic filter devices are used for channel selection (CF₂) while for FM, demodulation in LC-discriminator circuit (T₄, C₂₄, C₂₅) is used instead of a ceramic discriminator device.

Such an LC discriminator circuit can be easily matched to the FM IF selectivity block by its alignment. The zero-crossing of the discriminator can be detected at the demodulator output (pin 23). The zero-crossing voltage is equal to half of the regulated voltage at pin 8.

The alignment of the LC-discriminator circuit should be done with little or no effect on the AFC function. This can be realized by:

- switching pin 21 to an open-circuit
- connecting pin 1 to a voltage source of 2 V
- using a low signal level for alignment

In principle, ceramic discriminator devices can also be used. In this case, the effect of unavoidable spreads in the frequency characteristics of these case ceramic devices have to be considered. For example, mismatches of the characteristics between selectivity block and FM discriminator will lead to an increased signal-to-noise ratio at low signal levels as well as to a higher demodulation distortion level or to an asymmetrical AFC.

Application Circuits

Figure 17. Application Circuit for Low-cost Applications

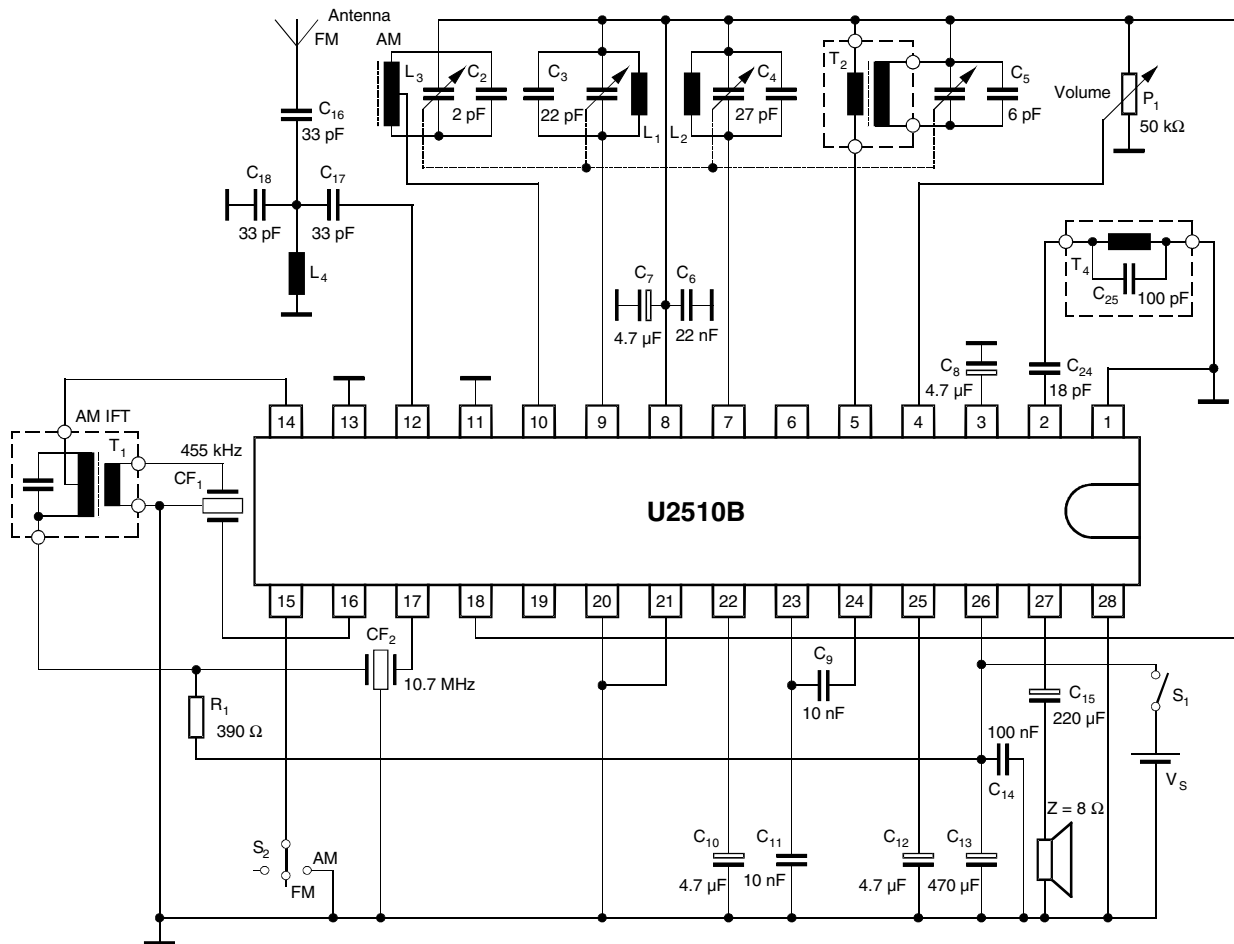


Figure 18. Application Circuit (Upgraded), R_2 Only if $V_S > 8\text{ V}$

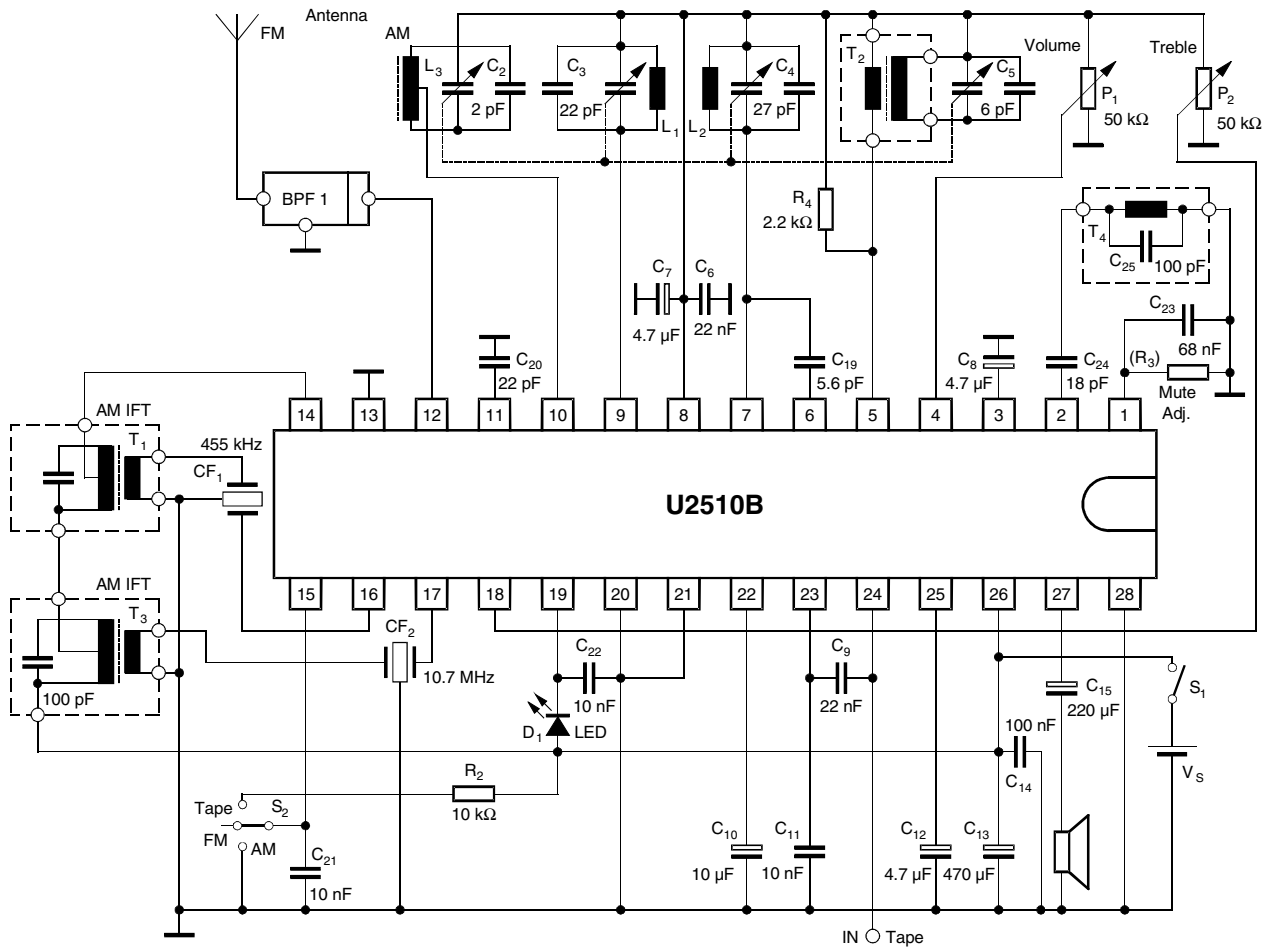
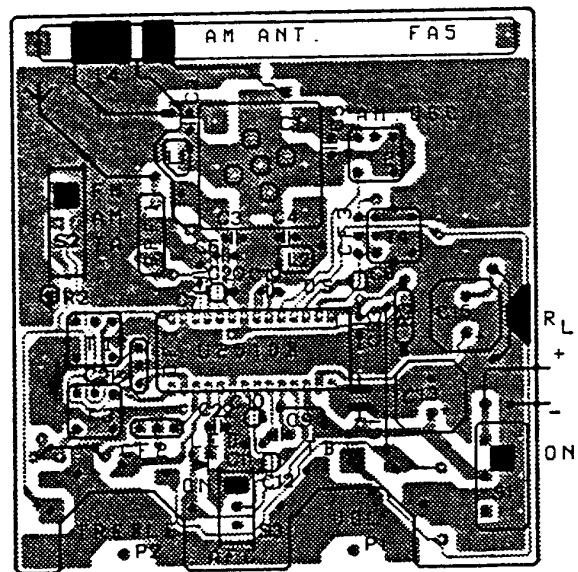
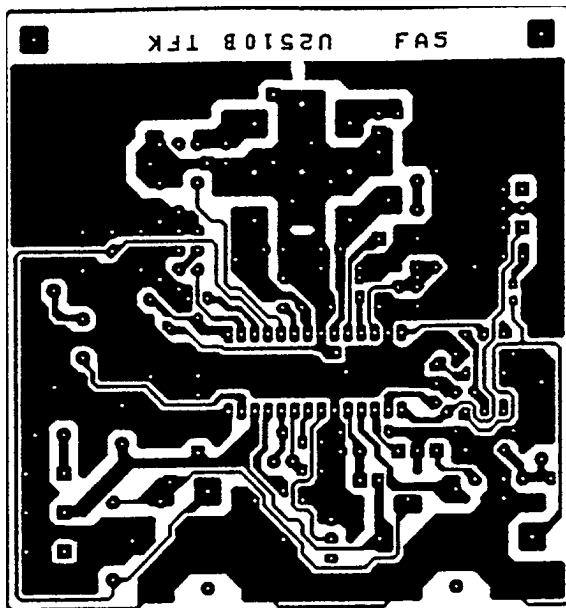


Figure 19. PC Board

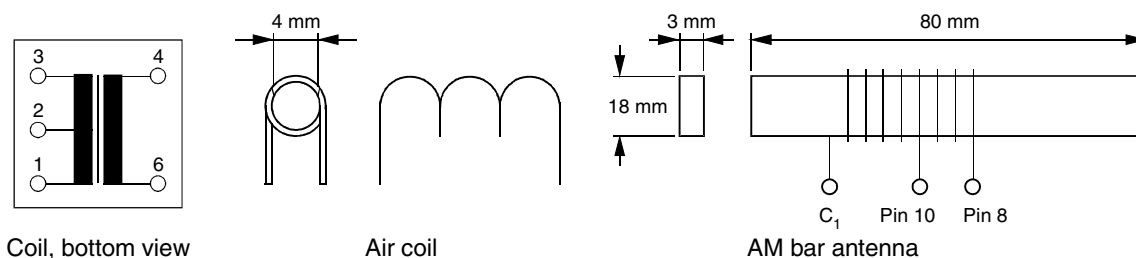


Coil Data and Components

Part	Stage	L or C ₀	Wire Diameter/mm			Type Manufacturer
			Terminal Number	Number of Turns		
T ₁	AM IFT	180 pF 1 to 3	0.07 1 to 2 111	0.07 2 to 3 35	0.07 4 to 6 7	7MC-7789N Toko® 21K7-H5 Mitsumi®
T ₂	AM OSC	270 mH 1 to 3	0.06 1 to 3 107	0.06 4 to 6 29		7TRS-8441 Toko L-5K7-H5 Mitsumi
T ₃	FM IFT (optional)	100 pF 1 to 3	0.09 1 to 2 3	0.09 2 to 3 7	0.09 4 to 6 2	7P A119 AC Toko
T ₄	FM discriminator	100 pF 1 to 3	0.09 1 to 3 10			7P A119 AC Toko
L ₁	FM RF air coil 4 mm diameter		0.62 3.75			
L ₂	FM OSC air coil 4 mm diameter		0.62 3.75			
L ₄	FM antenna air coil 4 mm diameter		0.62 4.75			

Part	Stage	Type	Manufacturer
L ₃	AM bar antenna	L: 630 μH total turns : 96 tap: 19	
BPF1	(optional)	PFWE8 (88 to 108 MHz)	Soshin Electric Co.
CF ₁		SFU-455B BFCFL-455	Murata® Toko
CF ₂		SFE10.7MA5 CFSK 107M1	Murata Toko
CF ₃	(optional)	CDA10.7MC1	Murata
C ₁	Variable capacitor	HD22124 AM/FM	Toko

Figure 20. Figure of Wirewound Components



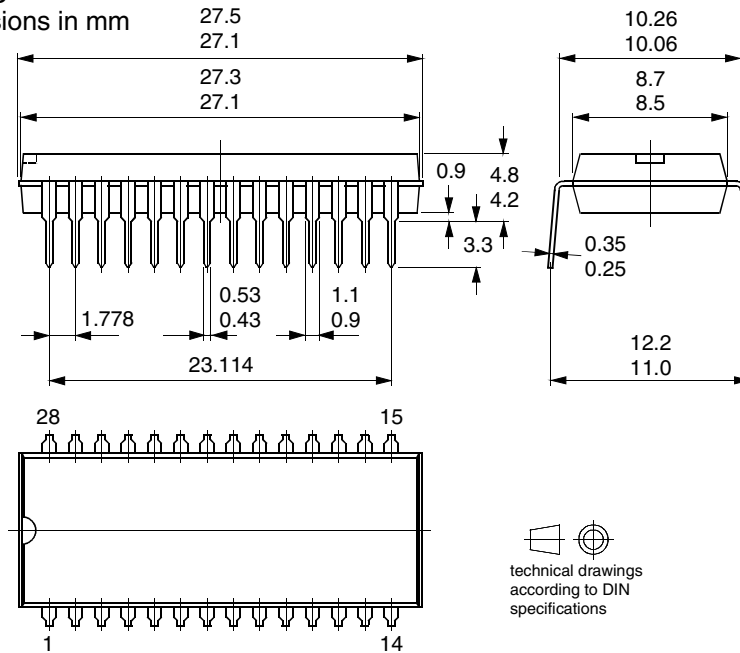
Ordering Information

Extended Type Number	Package	Remarks
U2510B-M	SDIP28	–

Package Information

Package SDIP28

Dimensions in mm





Atmel Corporation

2325 Orchard Parkway
San Jose, CA 95131, USA
Tel: 1(408) 441-0311
Fax: 1(408) 487-2600

Regional Headquarters

Europe

Atmel Sarl
Route des Arsenaux 41
Case Postale 80
CH-1705 Fribourg
Switzerland
Tel: (41) 26-426-5555
Fax: (41) 26-426-5500

Asia

Room 1219
Chinachem Golden Plaza
77 Mody Road Tsimshatsui
East Kowloon
Hong Kong
Tel: (852) 2721-9778
Fax: (852) 2722-1369

Japan

9F, Tonetsu Shinkawa Bldg.
1-24-8 Shinkawa
Chuo-ku, Tokyo 104-0033
Japan
Tel: (81) 3-3523-3551
Fax: (81) 3-3523-7581

Atmel Operations

Memory

2325 Orchard Parkway
San Jose, CA 95131, USA
Tel: 1(408) 441-0311
Fax: 1(408) 436-4314

Microcontrollers

2325 Orchard Parkway
San Jose, CA 95131, USA
Tel: 1(408) 441-0311
Fax: 1(408) 436-4314

La Chantrerie
BP 70602
44306 Nantes Cedex 3, France
Tel: (33) 2-40-18-18-18
Fax: (33) 2-40-18-19-60

ASIC/ASSP/Smart Cards

Zone Industrielle
13106 Rousset Cedex, France
Tel: (33) 4-42-53-60-00
Fax: (33) 4-42-53-60-01

1150 East Cheyenne Mtn. Blvd.
Colorado Springs, CO 80906, USA
Tel: 1(719) 576-3300
Fax: 1(719) 540-1759

Scottish Enterprise Technology Park
Maxwell Building
East Kilbride G75 0QR, Scotland
Tel: (44) 1355-803-000
Fax: (44) 1355-242-743

RF/Automotive

Theresienstrasse 2
Postfach 3535
74025 Heilbronn, Germany
Tel: (49) 71-31-67-0
Fax: (49) 71-31-67-2340

1150 East Cheyenne Mtn. Blvd.
Colorado Springs, CO 80906, USA
Tel: 1(719) 576-3300
Fax: 1(719) 540-1759

Biometrics/Imaging/Hi-Rel MPU/ High Speed Converters/RF Datacom

Avenue de Rochepleine
BP 123
38521 Saint-Egreve Cedex, France
Tel: (33) 4-76-58-30-00
Fax: (33) 4-76-58-34-80

Literature Requests

www.atmel.com/literature

Disclaimer: Atmel Corporation makes no warranty for the use of its products, other than those expressly contained in the Company's standard warranty which is detailed in Atmel's Terms and Conditions located on the Company's web site. The Company assumes no responsibility for any errors which may appear in this document, reserves the right to change devices or specifications detailed herein at any time without notice, and does not make any commitment to update the information contained herein. No licenses to patents or other intellectual property of Atmel are granted by the Company in connection with the sale of Atmel products, expressly or by implication. Atmel's products are not authorized for use as critical components in life support devices or systems.

© Atmel Corporation 2004. All rights reserved.

Atmel® and combinations thereof are the registered trademarks of Atmel Corporation or its subsidiaries.
Toko® is a registered trademark of TOKO KABUSHIKI KAISHA TA Toko, Inc.
Mitsumi® is a registered trademark of MITSUMI DENKI KABUSHIKI KAISHA CORPORATION JAPAN.
Murata® is a registered trademark of Murata Manufacturing Co., Ltd. CORPORATION Japan.

Other terms and product names may be the trademarks of others.





Printed on recycled paper.

4759A-AUDR-03/04

Looking for pricing, stock, or lifecycle information?

Click below to explore more details on WIN SOURCE:

-  [View U2510B-M on WIN SOURCE](#)
-  [Microchip Technology](#) Information

Optimize Your Supply Chain with WIN SOURCE Solutions

-  Global Sourcing Solution
-  Obsolete Management
-  Cost Control Management
-  Shortage Management
-  Alternative Solution
-  Excess Inventory Management