

Octal E1 Line Interface Unit

Features

- Octal E1 Short-haul Line Interface Unit
- Low Power
- No External Component Changes for 120 Ω / 75 Ω Operation
- Pulse Shapes can be customized by the user
- Internal AMI, or HDB3 Encoding/Decoding
- LOS Detection per ITU G.775 or ETSI 300-233
- G.772 Non-Intrusive Monitoring
- G.703 BITS Clock Recovery
- Crystal-less Jitter Attenuation
- Serial/Parallel Microprocessor Control Interfaces
- Transmitter Short Circuit Current Limiter (<50 mA)
- TX Drivers with Fast High-Z and Power Down
- JTAG Boundary Scan compliant to IEEE 1149.1
- 144-Pin LQFP or 160-Pin FBGA Package

ORDERING INFORMATION

CS61880-IQ	144-pin LQFP
CS61880-IB	160-pin FBGA

Description

The CS61880 is a full-featured Octal E1 short-haul LIU that supports 2.048 Mbps data transmission for both E1 75 Ω and E1 120 Ω applications. Each channel provides crystal-less jitter attenuation that complies with the most stringent standards. Each channel also provides internal AMI/HDB3 encoding/decoding. To support enhanced system diagnostics, channel zero can be configured for G.772 non-intrusive monitoring of any of the other 7 channels' receive or transmit paths.

The CS61880 makes use of ultra low power matched impedance transmitters and receivers to reduce power beyond that achieved by traditional driver designs. By achieving a more precise line match, this technique also provides superior return loss characteristics. Additionally, the internal line matching circuitry reduces the external component count. All transmitters have controls for independent power down and High-Z.

Each receiver provides reliable data recovery with over 12 dB of cable attenuation. The receiver also incorporates LOS detection compliant to the most recent specifications.

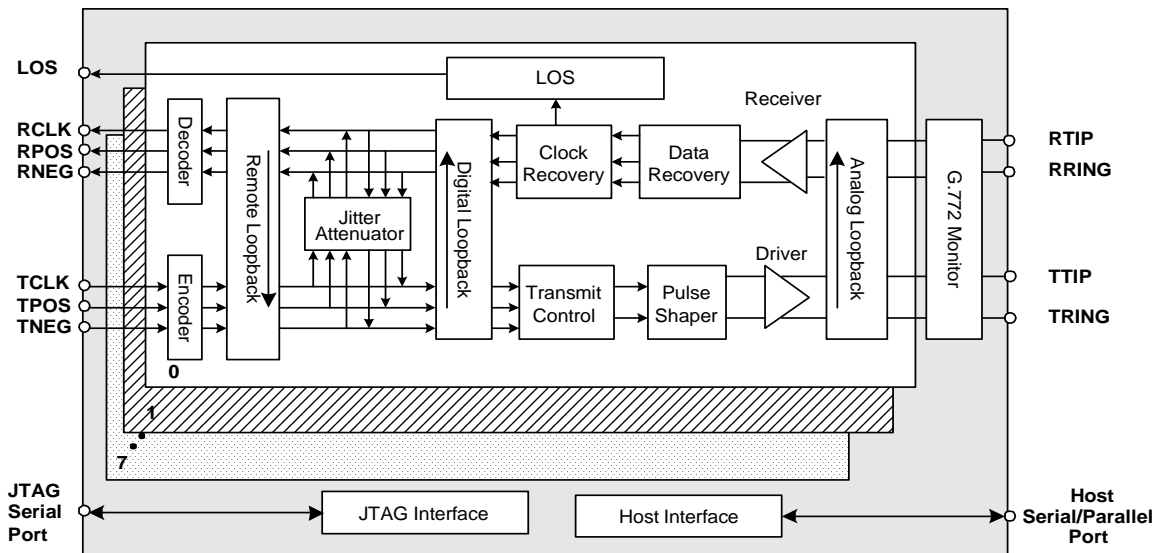

Preliminary Product Information

This document contains information for a new product. Cirrus Logic reserves the right to modify this product without notice.

TABLE OF CONTENTS

1. PIN OUT - 144-PIN LQFP PACKAGE	7
2. PIN OUT - 160-BALL FBGA PACKAGE	8
3. PIN DESCRIPTIONS	9
3.1 Power Supplies	9
3.2 Control	10
3.3 Address Inputs/Loopbacks	14
3.4 Cable Select	15
3.5 Status	15
3.6 Digital Rx/Tx Data I/O	16
3.7 Analog RX/TX Data I/O	19
3.8 JTAG Test Interface	21
3.9 Miscellaneous	21
4. OPERATION	22
5. POWER-UP	22
6. MASTER CLOCK	22
7. G.772 MONITORING	22
8. BUILDING INTEGRATED TIMING SYSTEMS (BITS) CLOCK MODE	23
9. TRANSMITTER	24
9.1 Bipolar Mode	24
9.2 Unipolar Mode	24
9.3 RZ Mode	25
9.4 Transmitter Powerdown / High-Z	25
9.5 Transmit All Ones (TAOS)	25
9.6 Automatic TAOS	25
9.7 Driver Failure Monitor	25
9.8 Driver Short Circuit Protection	25

Contacting Cirrus Logic Support

For all product questions and inquiries contact a Cirrus Logic Sales Representative.

To find the one nearest to you go to: <http://www.cirrus.com/>

IMPORTANT NOTICE

"Preliminary" product information describes products that are in production, but for which full characterization data is not yet available. Cirrus Logic, Inc. and its subsidiaries ("Cirrus") believe that the information contained in this document is accurate and reliable. However, the information is subject to change without notice and is provided "AS IS" without warranty of any kind (express or implied). Customers are advised to obtain the latest version of relevant information to verify, before placing orders, that information being relied on is current and complete. All products are sold subject to the terms and conditions of sale supplied at the time of order acknowledgment, including those pertaining to warranty, patent infringement, and limitation of liability. No responsibility is assumed by Cirrus for the use of this information, including use of this information as the basis for manufacture or sale of any items, or for infringement of patents or other rights of third parties. This document is the property of Cirrus and by furnishing this information, Cirrus grants no license, express or implied under any patents, mask work rights, copyrights, trademarks, trade secrets or other intellectual property rights. Cirrus owns the copyrights associated with the information contained herein and gives consent for copies to be made of the information only for use within your organization with respect to Cirrus integrated circuits or other products of Cirrus. This consent does not extend to other copying such as copying for general distribution, advertising or promotional purposes, or for creating any work for resale.

An export permit needs to be obtained from the competent authorities of the Japanese Government if any of the products or technologies described in this material and controlled under the "Foreign Exchange and Foreign Trade Law" is to be exported or taken out of Japan. An export license and/or quota needs to be obtained from the competent authorities of the Chinese Government if any of the products or technologies described in this material is subject to the PRC Foreign Trade Law and is to be exported or taken out of the PRC.

CERTAIN APPLICATIONS USING SEMICONDUCTOR PRODUCTS MAY INVOLVE POTENTIAL RISKS OF DEATH, PERSONAL INJURY, OR SEVERE PROPERTY OR ENVIRONMENTAL DAMAGE ("CRITICAL APPLICATIONS"). CIRRUS PRODUCTS ARE NOT DESIGNED, AUTHORIZED OR WARRANTED FOR USE IN AIRCRAFT SYSTEMS, MILITARY APPLICATIONS, PRODUCTS SURGICALLY IMPLANTED INTO THE BODY, LIFE SUPPORT PRODUCTS OR OTHER CRITICAL APPLICATIONS (INCLUDING MEDICAL DEVICES, AIRCRAFT SYSTEMS OR COMPONENTS AND PERSONAL OR AUTOMOTIVE SAFETY OR SECURITY DEVICES). INCLUSION OF CIRRUS PRODUCTS IN SUCH APPLICATIONS IS UNDERSTOOD TO BE FULLY AT THE CUSTOMER'S RISK AND CIRRUS DISCLAIMS AND MAKES NO WARRANTY, EXPRESS, STATUTORY OR IMPLIED, INCLUDING THE IMPLIED WARRANTIES OF MERCHANTABILITY AND FITNESS FOR PARTICULAR PURPOSE, WITH REGARD TO ANY CIRRUS PRODUCT THAT IS USED IN SUCH A MANNER. IF THE CUSTOMER OR CUSTOMER'S CUSTOMER USES OR PERMITS THE USE OF CIRRUS PRODUCTS IN CRITICAL APPLICATIONS, CUSTOMER AGREES, BY SUCH USE, TO FULLY INDEMNIFY CIRRUS, ITS OFFICERS, DIRECTORS, EMPLOYEES, DISTRIBUTORS AND OTHER AGENTS FROM ANY AND ALL LIABILITY, INCLUDING ATTORNEYS' FEES AND COSTS, THAT MAY RESULT FROM OR ARISE IN CONNECTION WITH THESE USES.

Cirrus Logic, Cirrus, and the Cirrus Logic logo designs are trademarks of Cirrus Logic, Inc. All other brand and product names in this document may be trademarks or service marks of their respective owners.

Intel is a registered trademark of Intel Corporation.

Motorola is a registered trademark of Motorola, Inc.

10. RECEIVER	26
10.1 Bipolar Output Mode	26
10.2 Unipolar Output Mode	26
10.3 RZ Output Mode	26
10.4 Receiver Powerdown/High-Z	27
10.5 Loss-of-Signal (LOS)	27
10.6 Alarm Indication Signal (AIS)	27
11. JITTER ATTENUATOR	28
12. OPERATIONAL SUMMARY	29
12.1 Loopbacks	29
12.2 Analog Loopback	29
12.3 Digital Loopback	30
12.4 Remote Loopback	30
13. HOST MODE	32
13.1 SOFTWARE RESET	32
13.2 Serial Port Operation	32
13.3 Parallel Port Operation	33
13.4 Register Set	34
14. REGISTER DESCRIPTIONS	35
14.1 Revision/IDcode Register (00h)	35
14.2 Analog Loopback Register (01h)	35
14.3 Remote Loopback Register (02h)	35
14.4 TAOS Enable Register (03h)	35
14.5 LOS Status Register (04h)	35
14.6 DFM Status Register (05h)	35
14.7 LOS Interrupt Enable Register (06h)	36
14.8 DFM Interrupt Enable Register (07h)	36
14.9 LOS Interrupt Status Register (08h)	36
14.10 DFM Interrupt Status Register (09h)	36
14.11 Software Reset Register (0Ah)	36
14.12 Performance Monitor Register (0Bh)	36
14.13 Digital Loopback Reset Register (0Ch)	36
14.14 LOS/AIS Mode Enable Register (0Dh)	37
14.15 Automatic TAOS Register (0Eh)	37
14.16 Global Control Register (0Fh)	37
14.17 Line Length Channel ID Register (10h)	38
14.18 Line Length Data Register (11h)	38
14.19 Output Disable Register (12h)	38
14.20 AIS Status Register (13h)	38
14.21 AIS Interrupt Enable Register (14h)	39
14.22 AIS Interrupt Status Register (15h)	39
14.23 AWG Broadcast Register (16h)	39
14.24 AWG Phase Address Register (17h)	39
14.25 AWG Phase Data Register (18h)	39
14.26 AWG Enable Register (19h)	40
14.27 Reserved Register (1Ah)	40
14.28 Reserved Register (1Bh)	40
14.29 Reserved Register (1Ch)	40
14.30 Reserved Register (1Dh)	40
14.31 Bits Clock Enable Register (1Eh)	40
14.32 Reserved Register (1Fh)	40
14.33 Status Registers	40
14.33.1 Interrupt Enable Registers	41

14.33.2 Interrupt Status Registers	41
15. ARBITRARY WAVEFORM GENERATOR	42
16. JTAG SUPPORT	43
16.1 TAP Controller	44
16.1.1 JTAG Reset	44
16.1.2 Test-Logic-Reset	44
16.1.3 Run-Test-Idle	44
16.1.4 Select-DR-Scan	44
16.1.5 Capture-DR	44
16.1.6 Shift-DR	44
16.1.7 Exit1-DR	44
16.1.8 Pause-DR	45
16.1.9 Exit2-DR	45
16.1.10 Update-DR	45
16.1.11 Select-IR-Scan	45
16.1.12 Capture-IR	45
16.1.13 Shift-IR	45
16.1.14 Exit1-IR	46
16.1.15 Pause-IR	46
16.1.16 Exit2-IR	46
16.1.17 Update-IR	46
16.2 Instruction Register (IR)	46
16.2.1 EXTEST	46
16.2.2 SAMPLE/PRELOAD	46
16.2.3 IDCODE	46
16.2.4 BYPASS	46
16.3 Device ID Register (IDR)	47
17. BOUNDARY SCAN REGISTER (BSR)	47
18. APPLICATIONS	50
18.1 Transformer Specifications	52
18.2 Crystal Oscillator Specifications	52
18.3 Line Protection	52
19. CHARACTERISTICS AND SPECIFICATIONS	53
19.1 Absolute Maximum Ratings	53
19.2 Recommended Operating Conditions	53
19.3 Digital Characteristics	54
19.4 Transmitter Analog Characteristics	54
19.5 Receiver Analog Characteristics	55
19.6 Jitter Attenuator Characteristics	56
19.7 Master Clock Switching Characteristics	58
19.8 Transmit Switching Characteristics	58
19.9 Receive Switching Characteristics	58
19.10 Switching Characteristics - Serial Port	60
19.11 Switching Characteristics - Parallel Port (Multiplexed Mode)	61
19.12 Switching Characteristics- Parallel Port (Non-Multiplexed Mode)	64
19.13 Switching Characteristics - JTAG	67
20. COMPLIANT RECOMMENDATIONS AND SPECIFICATIONS	68
21. 160-BALL FBGA PACKAGE DIMENSIONS	69
22. 144-PIN LQFP PACKAGE DIMENSIONS	70

LIST OF FIGURES

Figure 1. CS61880 144-Pin LQFP Package Pin Outs	7
Figure 2. CS61880 160-Ball FBGA Package Pin Outs	8
Figure 3. G.703 BITS Clock Mode in NRZ Mode	23
Figure 4. G.703 BITS Clock Mode in RZ Mode.....	23
Figure 5. G.703 BITS Clock Mode in Remote Loopback	23
Figure 6. Pulse Mask at E1 Interface	24
Figure 7. Analog Loopback Block Diagram	30
Figure 8. Analog Loopback with TAOS Block Diagram.....	30
Figure 9. Digital Loopback Block Diagram	31
Figure 10. Digital Loopback with TAOS	31
Figure 11. Remote Loopback Block Diagram	31
Figure 12. Serial Read/Write Format (SPOL = 0)	33
Figure 13. Arbitrary Waveform UI	42
Figure 14. Test Access Port Architecture.....	44
Figure 15. TAP Controller State Diagram	45
Figure 16. Internal RX/TX Impedance Matching	50
Figure 17. Internal TX, External RX Impedance Matching.....	51
Figure 18. Jitter Transfer Characteristic vs. G.736 & TBR 12/13.....	56
Figure 19. Jitter Tolerance Characteristic vs. G.823.....	57
Figure 20. Recovered Clock and Data Switching Characteristics.....	59
Figure 21. Transmit Clock and Data Switching Characteristics	59
Figure 22. Signal Rise and Fall Characteristics	59
Figure 23. Serial Port Read Timing Diagram	60
Figure 24. Serial Port Write Timing Diagram	60
Figure 25. Parallel Port Timing - Write; Intel® Multiplexed Address / Data Bus Mode	62
Figure 26. Parallel Port Timing - Read; Intel Multiplexed Address / Data Bus Mode.....	62
Figure 27. Parallel Port Timing - Write; Motorola® Multiplexed Address / Data Bus Mode	63
Figure 28. Parallel Port Timing - Read; Motorola Multiplexed Address / Data Bus Mode.....	63
Figure 29. Parallel Port Timing - Write; Intel Non-Multiplexed Address / Data Bus Mode	65
Figure 30. Parallel Port Timing - Read; Intel Non-Multiplexed Address / Data Bus Mode	65
Figure 31. Parallel Port Timing - Write; Motorola Non-Multiplexed Address / Data Bus Mode	66
Figure 32. Parallel Port Timing - Read; Motorola Non-Multiplexed Address / Data Bus Mode.....	66
Figure 33. JTAG Switching Characteristics.....	67
Figure 34. 160-Ball FBGA Package Drawing.....	69
Figure 35. 144-Pin LQFP Package Drawing	70

LIST OF TABLES

Table 1. Operation Mode Selection	10
Table 2. Mux/Bits Clock Selection	11
Table 3. Jitter Attenuation Selection	12
Table 4. Cable Impedance Selection	15
Table 5. Bipolar Mode Translations	16
Table 6. G.772 Address Selection	22
Table 7. Jitter Attenuator Configurations	28
Table 8. Operational Summary	29
Table 9. Host Control Signal Descriptions	32
Table 10. Host Mode Register Set	34
Table 11. Jitter Attenuator Position Selection	37
Table 12. Transmitter Pulse Shape Selection	38
Table 13. JTAG Instructions	46
Table 14. Boundary Scan Register	47
Table 15. Transformer Specifications	52
Table 16. 144-Pin Package Dimensions	70

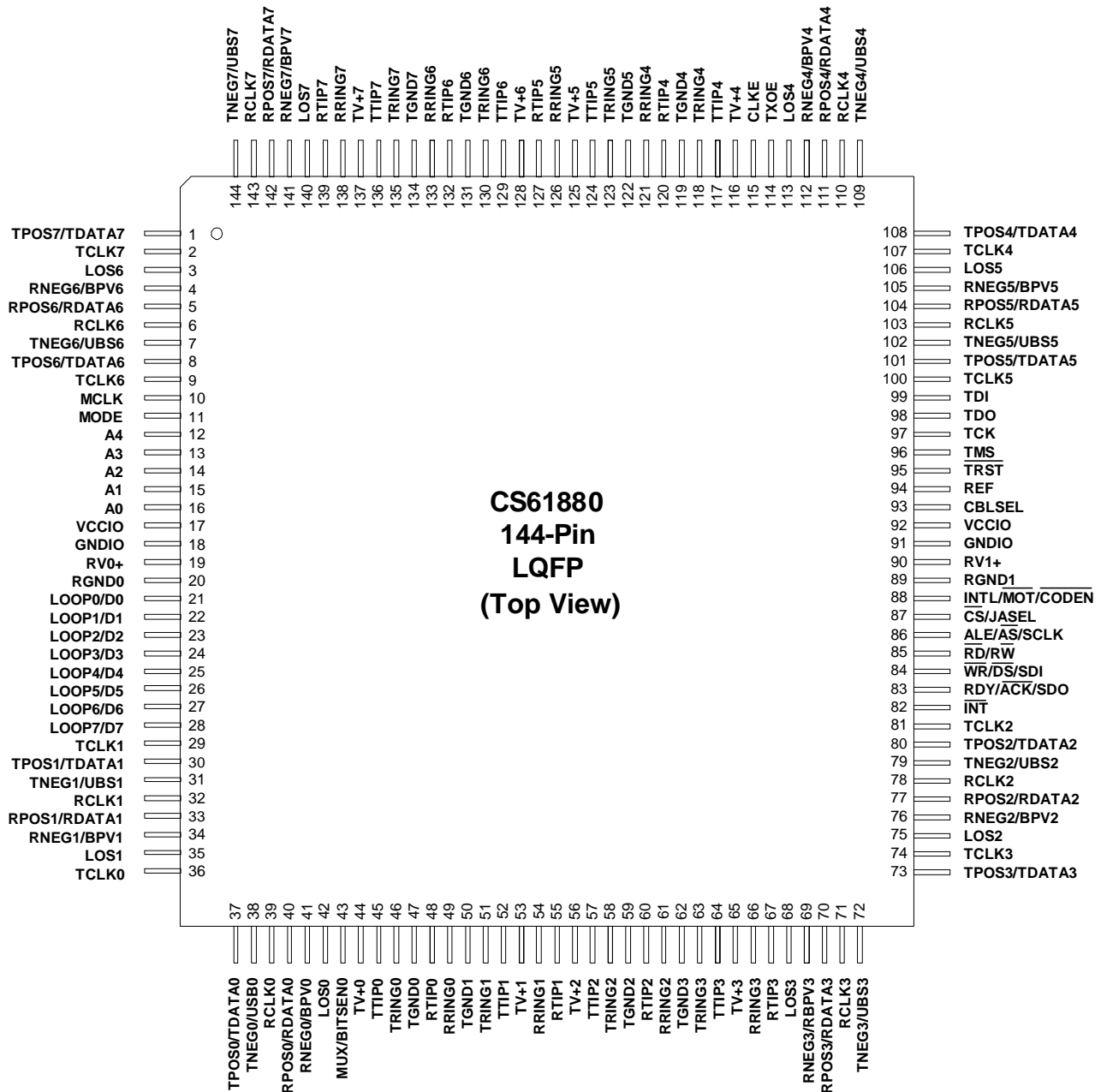
1. PIN OUT - 144-PIN LQFP PACKAGE

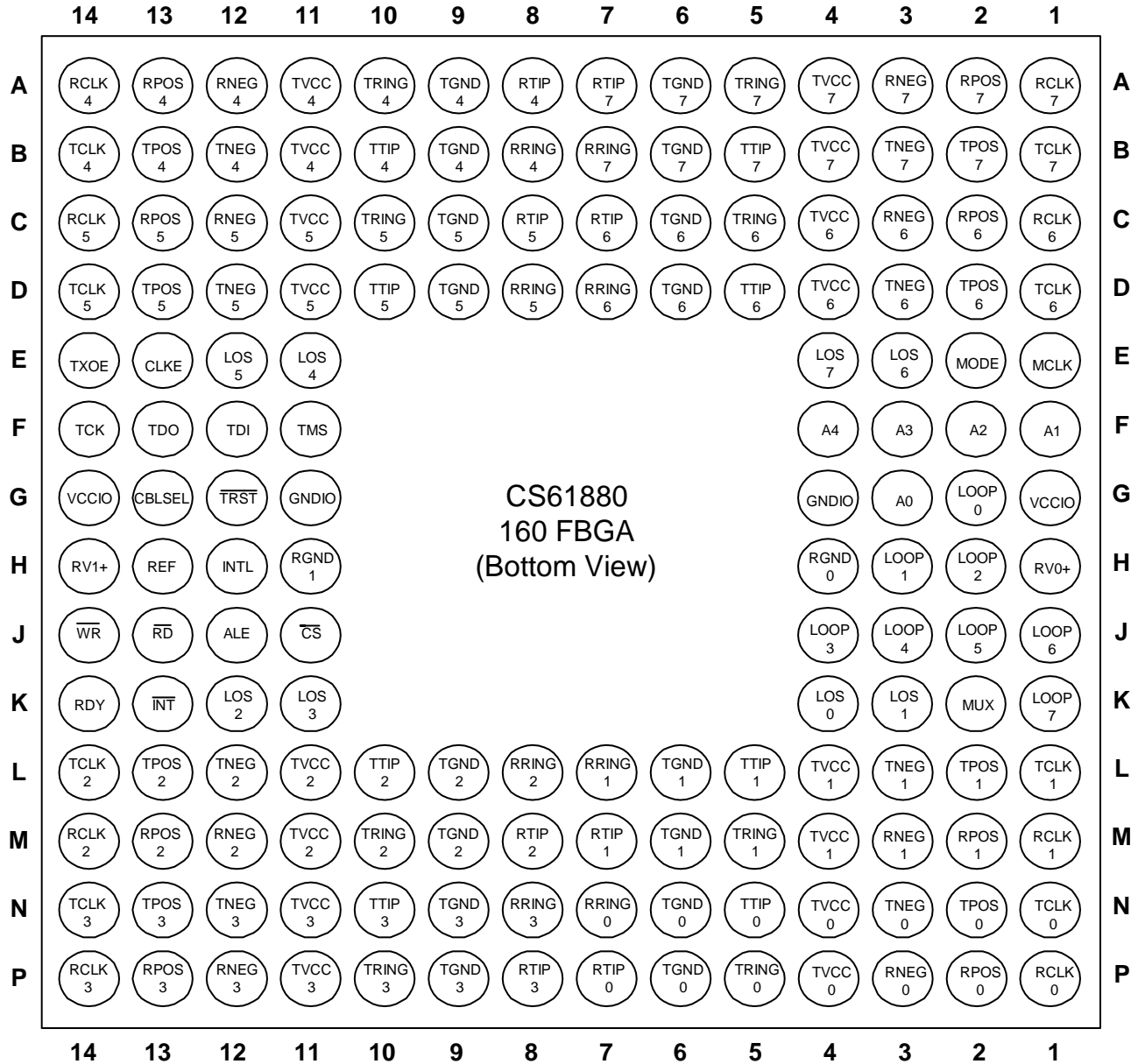
Figure 1. CS61880 144-Pin LQFP Package Pin Outs

2. PIN OUT - 160-BALL FBGA PACKAGE

Figure 2. CS61880 160-Ball FBGA Package Pin Outs

3. PIN DESCRIPTIONS

3.1 Power Supplies

SYMBOL	LQFP	FBGA	TYPE	DESCRIPTION
VCCIO	17 92	G1 G14		Power Supply, Digital Interface: Power supply for digital interface pins; typically 3.3 V
GNDIO	18 91	G4 G11		Ground, Digital Interface: Power supply ground for the digital interface; typically 0 V
RV0+ RV1+	19 90	H1 H14		Power Supply, Core Circuitry: Power supply for all sub-circuits except the transmit driver; typically +3.3 V
RGND0 RGND1	20 89	H4 H11		Ground, Core Circuitry: Ground for sub-circuits except the TX driver; typically 0 V
TV+0	44	N4, P4		Power Supply, Transmit Driver 0 Power supply for transmit driver 0; typically +3.3 V
TGND0	47	N6, P6		Ground, Transmit Driver 0 Power supply ground for transmit driver 0; typically 0 V
TV+1	53	L4, M4		Power Supply, Transmit Driver 1
TGND1	50	L6, M6		Ground, Transmit Driver 1
TV+2	56	L11 M11		Power Supply, Transmit Driver 2
TGND2	59	L9, M9		Ground, Transmit Driver 2
TV+3	65	N11 P11		Power Supply, Transmit Driver 3
TGND3	62	N9, P9		Ground, Transmit Driver 3
TV+4	116	A11 B11		Power Supply, Transmit Driver 4
TGND4	119	A9, B9		Ground, Transmit Driver 4
TV+5	125	C11 D11		Power Supply, Transmit Driver 5
TGND5	122	C9, D9		Ground, Transmit Driver 5
TV+6	128	C4, D4		Power Supply, Transmit Driver 6
TGND6	131	C6, D6		Ground, Transmit Driver 6
TV+7	137	A4, B4		Power Supply, Transmit Driver 7
TGND7	134	A6, B6		Ground, Transmit Driver 7

3.2 Control

SYMBOL	LQFP	FBGA	TYPE	DESCRIPTION								
MCLK	10	E1	I	<p>Master Clock Input This pin is a free running reference clock that should be 2.048 MHz. This timing reference is used as follows:</p> <ul style="list-style-type: none"> - Timing reference for the clock recovery and jitter attenuation circuitry. - RCLK reference during Loss of Signal (LOS) conditions - Transmit clock reference during Transmit all Ones (TAOS) condition - Wait state timing for microprocessor interface - When this pin is held "High", the PLL clock recovery circuit is disabled. In this mode, the CS61880 receivers function as simple data slicers. - When this pin is held "Low", the receiver paths are powered down and the output pins RCLK, RPOS, and RNEG are High-Z. 								
MODE	11	E2	I	<p>Mode Select This pin is used to select whether the CS61880 operates in Serial host, Parallel host or Hardware mode.</p> <p>Host Mode - The CS61880 is controlled through either a serial or a parallel microprocessor interface (Refer to HOST MODE (See Section 13 on page 32).</p> <p>Hardware Mode - The microprocessor interface is disabled and the device control/status are provided through the pins on the device.</p> <p style="text-align: center;">Table 1. Operation Mode Selection</p> <table border="1" style="margin-left: auto; margin-right: auto;"> <thead> <tr> <th>Pin State</th> <th>OPERATING Mode</th> </tr> </thead> <tbody> <tr> <td>LOW</td> <td>Hardware Mode</td> </tr> <tr> <td>HIGH</td> <td>Parallel Host Mode</td> </tr> <tr> <td>VCCIO/2</td> <td>Serial Host Mode</td> </tr> </tbody> </table> <p>NOTE: For serial host mode connect this pin to a resistor divider consisting of two 10 kΩ resistors between VCCIO and GNDIO.</p>	Pin State	OPERATING Mode	LOW	Hardware Mode	HIGH	Parallel Host Mode	VCCIO/2	Serial Host Mode
Pin State	OPERATING Mode											
LOW	Hardware Mode											
HIGH	Parallel Host Mode											
VCCIO/2	Serial Host Mode											

SYMBOL	LQFP	FBGA	TYPE	DESCRIPTION									
MUX/BITSEN0	43	K2	I	<p>Multiplexed Interface/Bits Clock Select Host Mode -This pin configures the microprocessor interface for multiplexed or non-multiplexed operation. Hardware mode - This pin is used to enable channel 0 as a G.703 BITS Clock recovery channel (Refer to BUILDING INTEGRATED TIMING SYSTEMS (BITS) CLOCK MODE (See Section 8 on page 23). Channel 1 through 7 are not affected by this pin during hardware mode. During host mode the G.703 BITS Clock recovery function is enabled by the Bits Clock Enable Register (1Eh) (See Section 14.31 on page 40).</p> <p style="text-align: center;">Table 2. Mux/Bits Clock Selection</p> <table border="1" style="margin-left: auto; margin-right: auto;"> <thead> <tr> <th>Pin State</th> <th>Parallel Host Mode</th> <th>Hardware Mode</th> </tr> </thead> <tbody> <tr> <td>HIGH</td> <td>multiplexed</td> <td>BITS Clock ON</td> </tr> <tr> <td>LOW</td> <td>non multiplexed</td> <td>BITS Clock OFF</td> </tr> </tbody> </table> <p>NOTE: The MUX pin only controls the BITS Clock function in Hardware Mode</p>	Pin State	Parallel Host Mode	Hardware Mode	HIGH	multiplexed	BITS Clock ON	LOW	non multiplexed	BITS Clock OFF
Pin State	Parallel Host Mode	Hardware Mode											
HIGH	multiplexed	BITS Clock ON											
LOW	non multiplexed	BITS Clock OFF											
$\overline{\text{INT}}$	82	K13	O	<p>Interrupt Output This active low output signals the host processor when one of the CS61880's internal status register bits has changed state. When the status register is read, the interrupt is $\overline{\text{INT}}$ cleared. The various status changes that would force $\overline{\text{INT}}$ active are maskable via internal interrupt enable registers.</p> <p>NOTE: This pin is an open drain output and requires a 10 kΩ pull-up resistor.</p>									
RDY/ $\overline{\text{ACK}}$ /SDO	83	K14	O	<p>Ready/Data Transfer Acknowledge/Serial Data Output Intel Parallel Host Mode - During a read or write register access, RDY is asserted "Low" to acknowledge that the device has been accessed. An asserted "High" acknowledges that data has been written or read. Upon completion of the bus cycle, this pin High-Z. Motorola Parallel Host Mode - During a data bus read operation this pin, "ACK", is asserted "High" to indicate that data on the bus is valid. An asserted "Low" on this pin during a write operation acknowledges that a data transfer to the addressed register has been accepted. Upon completion of the bus cycle, this pin High-Z. NOTE: Wait state generation via RDY/$\overline{\text{ACK}}$ is disabled in RZ mode (No Clock Recovery). Serial Host Mode - When the microprocessor interface is configured for serial bus operation, "SDO" is used as a serial data output. This pin is forced into a high impedance state during a serial write access. The CLKE pin controls whether SDO is valid on the rising or falling edge of SCLK. Upon completion of the bus cycle, this pin High-Z. Hardware Mode - This pin is not used and should be left open.</p>									

SYMBOL	LQFP	FBGA	TYPE	DESCRIPTION								
$\overline{WR}/\overline{DS}/SDI$	84	J14	I	<p>Write Enable/Data Strobe/Serial Data Intel Parallel Host Mode - This pin, "\overline{WR}", functions as a write enable. Motorola Parallel Host Mode - This pin, "\overline{DS}", functions as a data strobe input. Serial Host Mode - This pin, "SDI", functions as the serial data input. Hardware Mode - This pin is not used and should be connected to ground.</p>								
$\overline{RD}/\overline{RW}$	85	J13	I	<p>Read Enable/Read/Write Intel Parallel Host Mode - This pin, "\overline{RD}", functions as a read enable. Motorola Parallel Host Mode - This pin, "R/\overline{W}", functions as the read/write input signal. Hardware Mode - This pin is not used and should be connected to ground.</p>								
$ALE/\overline{AS}/SCLK$	86	J12	I	<p>Address Latch Enable/Address Strobe/Serial Clock Intel Parallel Host Mode - This pin, "ALE", functions as the Address Latch Enable when configured for multiplexed address/data operation. Motorola Parallel Host Mode - This pin, "\overline{AS}", functions as the active "low" address strobe when configured for multiplexed address/data operation. Serial Host Mode - This pin, "SCLK", is the serial clock used for data I/O on SDI and SDO. Hardware Mode - This pin is not used and should be connected to ground.</p>								
$\overline{CS}/JASEL$	87	J11	I	<p>Chip Select Input/Jitter Attenuator Select Host Mode - This active low input is used to enable accesses to the microprocessor interface in either serial or parallel mode. Hardware Mode - This pin controls the position of the Jitter Attenuator.</p> <p style="text-align: center;">Table 3. Jitter Attenuation Selection</p> <table border="1" style="margin-left: auto; margin-right: auto;"> <thead> <tr> <th>Pin State</th> <th>Jitter Attenuation Position</th> </tr> </thead> <tbody> <tr> <td>LOW</td> <td>Transmit Path</td> </tr> <tr> <td>HIGH</td> <td>Receive Path</td> </tr> <tr> <td>OPEN</td> <td>Disabled</td> </tr> </tbody> </table>	Pin State	Jitter Attenuation Position	LOW	Transmit Path	HIGH	Receive Path	OPEN	Disabled
Pin State	Jitter Attenuation Position											
LOW	Transmit Path											
HIGH	Receive Path											
OPEN	Disabled											

SYMBOL	LQFP	FBGA	TYPE	DESCRIPTION
INTL/ <u>MOT</u> / <u>CODEN</u>	88	H12	I	<p>Intel/Motorola/Coder Mode Select Input</p> <p>Parallel Host Mode - When this pin is “Low” the microprocessor interface is configured for operation with Motorola processors. When this pin is “High” the microprocessor interface is configured for operation with Intel processors.</p> <p>Hardware Mode - When the CS61880 is configured for unipolar operation, this pin, <u>CODEN</u>, configures the line encoding/decoding function. When <u>CODEN</u> is low, HDB3 encoders/decoders are enabled. When <u>CODEN</u> is high, AMI encoding/decoding is activated. This is done for all eight channels.</p>
TXOE	114	E14	I	<p>Transmitter Output Enable</p> <p>Host mode - Operates the same as in hardware mode. Individual drivers can be set to a high impedance state via the Output Disable Register (12h) (See Section 14.19 on page 38).</p> <p>Hardware Mode - When TXOE pin is asserted Low, all the TX drivers are forced into a high impedance state. All other internal circuitry remains active.</p>
CLKE	115	E13	I	<p>Clock Edge Select</p> <p>In clock/data recovery mode, setting CLKE “high” will cause RPOS/RNEG to be valid on the falling edge of RCLK and SDO to be valid on the rising edge of SCLK. When CLKE is set “low”, RPOS/RNEG is valid on the rising edge of RCLK, and SDO is valid on the falling edge of SCLK. When the part is operated in data recovery mode, the RPOS/RNEG output polarity is active “high” when CLKE is set “high” and active “low” when CLKE is set “low”.</p>

3.3 Address Inputs/Loopbacks

SYMBOL	LQFP	FBGA	TYPE	DESCRIPTION
A4	12	F4	I	<p>Address Selector Input</p> <p>Parallel Host Mode - During non-multiplexed parallel host mode operation, this pin function as the address 4 input for the parallel interface.</p> <p>Hardware Mode - The A4 pin must be tied low at all times.</p>
A3	13	F3	I	<p>Non-Intrusive Monitoring/Address Selector Inputs</p> <p>Parallel Host Mode - During non-multiplexed parallel host mode operation, these pins function as address A[3:0] inputs for the parallel interface.</p> <p>Hardware Mode - The A[3:0] pins are used for port selection during non-intrusive monitoring. In non-intrusive monitoring mode, receiver 0's input is internally connected to the transmit or receive ports on one of the other 7 channels. The recovered clock and data from the selected port are output on RPOS0/RNEG0 and RCLK0. Additionally, the data from the selected port can be output on TTIP0/TRING0 by activating the remote loopback function for channel 0 (Refer to Performance Monitor Register (0Bh) (See Section 14.12 on page 36).</p>
A2	14	F2	I	
A1	15	F1	I	
A0	16	G3	I	
LOOP0/D0	21	G2	I/O	<p>Loopback Mode Selector/Parallel Data Input/Output</p> <p>Parallel Host Mode - In non-multiplexed microprocessor interface mode, these pins function as the bi-directional 8-bit data port. When operating in multiplexed microprocessor interface mode, these pins function as the address and data inputs/outputs.</p> <p>Hardware Mode</p> <ul style="list-style-type: none"> - No Loopback - The CS61880 is in a normal operating state when LOOP is left open (unconnected) or tied to VCCIO/2. - Local Loopback - When LOOP is tied High, data transmitted on TTIP and TRING is looped back into the analog input of the corresponding channel's receiver and output on RPOS and RNEG. Input Data present on RTIP and RRING is ignored. - Remote Loopback - When LOOP is tied Low the recovered clock and data received on RTIP and RRING is looped back for transmission on TTIP and TRING. Data on TPOS and TNEG is ignored.
LOOP1/D1	22	H3	I/O	
LOOP2/D2	23	H2	I/O	
LOOP3/D3	24	J4	I/O	
LOOP4/D4	25	J3	I/O	
LOOP5/D5	26	J2	I/O	
LOOP6/D6	27	J1	I/O	
LOOP7/D7	28	K1	I/O	

3.4 Cable Select

SYMBOL	LQFP	FBGA	TYPE	DESCRIPTION												
CBLSEL	93	G13	I	<p>Cable Impedance Select Host Mode - The input voltage to this pin does not effect normal operation. Hardware Mode - This pin is used to select the transmitted pulse shape and set the line impedance for all eight receivers and transmitters. This pin also selects whether or not all eight receivers use an internal or external line matching network (Refer to the Table 4 below for proper settings).</p> <p style="text-align: center;">Table 4. Cable Impedance Selection</p> <table border="1" style="margin-left: auto; margin-right: auto;"> <thead> <tr> <th>CBLSEL</th> <th>Transmitters</th> <th>Receivers</th> </tr> </thead> <tbody> <tr> <td>No Connect</td> <td>120 Ω Internal</td> <td>120 Ω Internal or External</td> </tr> <tr> <td>HIGH</td> <td>75 Ω Internal</td> <td>75 Ω Internal</td> </tr> <tr> <td>LOW</td> <td>75 Ω Internal</td> <td>75 Ω External</td> </tr> </tbody> </table> <p>NOTE: Refer to Figure 16 on page 50 and Figure 17 on page 51 for appropriate external line matching components. All transmitters use internal matching networks.</p>	CBLSEL	Transmitters	Receivers	No Connect	120 Ω Internal	120 Ω Internal or External	HIGH	75 Ω Internal	75 Ω Internal	LOW	75 Ω Internal	75 Ω External
CBLSEL	Transmitters	Receivers														
No Connect	120 Ω Internal	120 Ω Internal or External														
HIGH	75 Ω Internal	75 Ω Internal														
LOW	75 Ω Internal	75 Ω External														

3.5 Status

SYMBOL	LQFP	FBGA	TYPE	DESCRIPTION
LOS0	42	K4	O	<p>Loss of Signal Output</p> <p>The LOS output pins can be configured to indicate a loss of signal (LOS) state that is compliant to either ITU G.775 or ETSI 300 233. These pins are asserted “High” to indicate LOS. The LOS output returns low when an input signal is present for the time period dictated by the associated specification (Refer to Loss-of-Signal (LOS) (See Section 10.5 on page 27)).</p>
LOS1	35	K3	O	
LOS2	75	K12	O	
LOS3	68	K11	O	
LOS4	113	E11	O	
LOS5	106	E12	O	
LOS6	3	E3	O	
LOS7	140	E4	O	

3.6 Digital Rx/Tx Data I/O

SYMBOL	LQFP	FBGA	TYPE	DESCRIPTION															
TCLK0	36	N1	I	<p>Transmit Clock Input Port 0</p> <ul style="list-style-type: none"> - When TCLK is active, the TPOS and TNEG pins function as NRZ inputs that are sampled on the falling edge of TCLK. - If MCLK is active, TAOS will be generated when TCLK is held High for 16 MCLK cycles. <p>NOTE: MCLK is used as the timing reference during TAOS and must have the appropriate stability.</p> <ul style="list-style-type: none"> - If TCLK is held High in the absence of MCLK, the TPOS and TNEG inputs function as RZ inputs. In this mode, the transmit pulse width is set by the pulse-width of the signal input on TPOS and TNEG. To enter this mode, TCLK must be held high for at least 12 μs. - If TCLK is held Low, the output drivers enter a low-power, high impedance state. 															
TPOS0/TDATA0 TNEG0/UBS	37 38	N2 N3	I I	<p>Transmit Positive Pulse/Transmit Data Input Port 0 Transmit Negative Pulse/Unipolar-Bipolar Select Port 0</p> <p>The function of the TPOS/TDATA and TNEG/UBS inputs are determined by whether Unipolar, Bipolar or RZ input mode has been selected.</p> <p>Bipolar Mode - In this mode, NRZ data on TPOS and TNEG are sampled on the falling edge of TCLK and transmitted onto the line at TTIP and TRING respectively. A “High” input on TPOS results in transmission of a positive pulse; a “High” input on TNEG results in a transmission of a negative pulse. The translation of TPOS/TNEG inputs to TTIP/TRING outputs is as follows:</p> <p style="text-align: center;">Table 5. Bipolar Mode Translations</p> <table border="1" style="margin-left: auto; margin-right: auto;"> <thead> <tr> <th>TPOS</th> <th>TNEG</th> <th>OUTPUT</th> </tr> </thead> <tbody> <tr> <td>0</td> <td>0</td> <td>Space</td> </tr> <tr> <td>1</td> <td>0</td> <td>Positive Mark</td> </tr> <tr> <td>0</td> <td>1</td> <td>Negative Mark</td> </tr> <tr> <td>1</td> <td>1</td> <td>Space</td> </tr> </tbody> </table> <p>Unipolar mode - Unipolar mode is activated by holding TNEG/UBS “High” for more than 16 TCLK cycles, when MCLK is present. The falling edge of TCLK samples a unipolar data stream on TPOS/TDATA.</p> <p>RZ Mode - To activate RZ mode tie TCLK “High” in the absence of MCLK. In this mode, the duty cycle of the TPOS and TNEG inputs determine the pulse width of the output signal on TTIP and TRING.</p>	TPOS	TNEG	OUTPUT	0	0	Space	1	0	Positive Mark	0	1	Negative Mark	1	1	Space
TPOS	TNEG	OUTPUT																	
0	0	Space																	
1	0	Positive Mark																	
0	1	Negative Mark																	
1	1	Space																	

SYMBOL	LQFP	FBGA	TYPE	DESCRIPTION
RCLK0	39	P1	O	<p>Receive Clock Output Port 0</p> <ul style="list-style-type: none"> - When MCLK is active, this pin outputs the recovered clock from the signal input on RTIP and RRING. In the event of LOS, the RCLK output transitions from the recovered clock to MCLK. - If MCLK is held "High", the clock recovery circuitry is disabled and the RCLK output is driven by the XOR of RNEG and RPOS. - If MCLK is held "Low", this output is in a high-impedance state.
RPOS0/RDATA0	40	P2	O	<p>Receive Positive Pulse/ Receive Data Output Port 0 Receive Negative Pulse/Bipolar Violation Output Port 0</p> <p>The function of the RPOS/RDATA and RNEG/BPV outputs are determined by whether Unipolar, Bipolar, or RZ input mode has been selected. During LOS, the RPOS/RNEG outputs will remain active.</p> <p>NOTE: The RPOS/RNEG outputs can be High-Z by holding MCLK Low.</p> <p>Bipolar Output Mode - When configured for Bipolar operation, NRZ Data is recovered from RTIP/RRING and output on RPOS/RNEG. A high signal on RPOS or RNEG correspond to the receipt of a positive or negative pulse on RTIP/RRING respectively. The RPOS/RNEG outputs are valid on the falling or rising edge of RCLK as configured by CLKE.</p> <p>Unipolar Output Mode - When unipolar mode is activated, the recovered data is output on RDATA. The decoder signals bipolar violations are output on the RNEG/BPV pin.</p> <p>RZ Output Mode - In this mode, the RPOS/RNEG pins output RZ data recovered by slicing the signal present on RTIP/RRING. A positive pulse on RTIP with respect to RRING generates a logic 1 on RPOS; a positive pulse on RRING with respect to RTIP generates a logic 1 on RNEG. The polarity of the output on RPOS/RNEG is selectable using the CLKE pin. In this mode, external circuitry is used to recover clock from the received signal.</p>
RNEG0/BPV0	41	P3	O	
TCLK1	29	L1	I	Transmit Clock Input Port 1
TPOS1/TDATA1	30	L2	I	Transmit Positive Pulse/Transmit Data Input Port 1
TNEG1/UBS1	31	L3	I	Transmit Negative Pulse/Unipolar-Bipolar Select Port 1
RCLK1	32	M1	O	Receive Clock Output Port 1
RPOS1/RDATA1	33	M2	O	Receive Positive Pulse/ Receive Data Output Port 1
RNEG1/BPV1	34	M3	O	Receive Negative Pulse/Bipolar Violation Output Port 1
TCLK2	81	L14	I	Transmit Clock Input Port 2
TPOS2/TDATA2	80	L13	I	Transmit Positive Pulse/Transmit Data Input Port 2
TNEG2/UBS2	79	L12	I	Transmit Negative Pulse/Unipolar-Bipolar Select Port 2

SYMBOL	LQFP	FBGA	TYPE	DESCRIPTION
RCLK2	78	M14	O	Receive Clock Output Port 2
RPOS2/RDATA2	77	M13	O	Receive Positive Pulse/ Receive Data Output Port 2
RNEG2/BPV2	76	M12	O	Receive Negative Pulse/Bipolar Violation Output Port 2
TCLK3	74	N14	I	Transmit Clock Input Port 3
TPOS3/TDATA3	73	N13	I	Transmit Positive Pulse/Transmit Data Input Port 3
TNEG3/UBS3	72	N12	I	Transmit Negative Pulse/Unipolar-Bipolar Select Port 3
RCLK3	71	P14	O	Receive Clock Output Port 3
RPOS3/RDATA3	70	P13	O	Receive Positive Pulse/ Receive Data Output Port 3
RNEG3/BPV3	69	P12	O	Receive Negative Pulse/Bipolar Violation Output Port 3
TCLK4	107	B14	I	Transmit Clock Input Port 4
TPOS4/TDATA4	108	B13	I	Transmit Positive Pulse/Transmit Data Input Port 4
TNEG4/UBS4	109	B12	I	Transmit Negative Pulse/Unipolar-Bipolar Select Port 4
RCLK4	110	A14	O	Receive Clock Output Port 4
RPOS4/RDATA4	111	A13	O	Receive Positive Pulse/ Receive Data Output Port 4
RNEG4/BPV4	112	A12	O	Receive Negative Pulse/Bipolar Violation Output Port 4
TCLK5	100	D14	I	Transmit Clock Input Port 5
TPOS5/TDATA5	101	D13	I	Transmit Positive Pulse/Transmit Data Input Port 5
TNEG5/UBS5	102	D12	I	Transmit Negative Pulse/Unipolar-Bipolar Select Port 5
RCLK5	103	C14	O	Receive Clock Output Port 5
RPOS5/RDATA5	104	C13	O	Receive Positive Pulse/ Receive Data Output Port 5
RNEG5/BPV5	105	C12	O	Receive Negative Pulse/Bipolar Violation Output Port 5
TCLK6	9	D1	I	Transmit Clock Input Port 6
TPOS6/TDATA6	8	D2	I	Transmit Positive Pulse/Transmit Data Input Port 6
TNEG6/UBS6	7	D3	I	Transmit Negative Pulse/Unipolar-Bipolar Select Port 6
RCLK6	6	C1	O	Receive Clock Output Port 6
RPOS6/RDATA6	5	C2	O	Receive Positive Pulse/ Receive Data Output Port 6
RNEG6/BPV6	4	C3	O	Receive Negative Pulse/Bipolar Violation Output Port 6
TCLK7	2	B1	I	Transmit Clock Input Port 7
TPOS7/TDATA7	1	B2	I	Transmit Positive Pulse/Transmit Data Input Port 7
TNEG7/UBS7	144	B3	I	Transmit Negative Pulse/Unipolar-Bipolar Select Port 7

SYMBOL	LQFP	FBGA	TYPE	DESCRIPTION
RCLK7	143	A1	O	Receive Clock Output Port 7
RPOS7/RDATA7	142	A2	O	Receive Positive Pulse/ Receive Data Output Port 7
RNEG7/BPV7	141	A3	O	Receive Negative Pulse/Bipolar Violation Output Port 7

3.7 Analog RX/TX Data I/O

SYMBOL	LQFP	FBGA	TYPE	DESCRIPTION
TTIP0	45	N5	O	Transmit Tip Output Port 0 Transmit Ring Output Port 0 These pins are the differential outputs of the transmit driver. The driver internally matches impedances for E1 75 Ω or E1 120 Ω lines requiring only a 1:1.15 transformer. The CBLSEL pin is used to select the appropriate line matching impedance only in “Hardware” mode. In host mode, the appropriate line matching impedance is selected by the Line Length Data Register (11h) (See Section 14.18 on page 38). NOTE: TTIP and TRING are forced to a high impedance state when the TCLK or the TXOE pin is forced “Low”.
TRING0	46	P5	O	
RTIP0	48	P7	I	Receive Tip Input Port 0 Receive Ring Input Port 0 These pins are the differential line inputs to the receiver. The receiver uses either Internal Line Impedance or External Line Impedance modes to match the line impedances for E1 75Ω or E1 120Ω modes. Internal Line Impedance Mode - The receiver uses the same external resistors to match the line impedance (Refer to Figure 16 on page 50). External Line Impedance Mode - The receiver uses different external resistors to match the line impedance (Refer to Figure 17 on page 51). - In host mode, the appropriate line impedance is selected by the Line Length Data Register (11h) (See Section 14.18 on page 38). - In hardware mode, the CBLSEL pin selects the appropriate line impedance. (Refer to Table 4 on page 15 for proper line impedance settings). NOTE: Data and clock recovered from the signal input on these pins are output via RCLK, RPOS, and RNEG.
RRING0	49	N7	I	
TTIP1	52	L5	O	Transmit Tip Output Port 1
TRING1	51	M5	O	Transmit Ring Output Port 1
RTIP1	55	M7	I	Receive Tip Input Port 1
RRING1	54	L7	I	Receive Ring Input Port 1
TTIP2	57	L10	O	Transmit Tip Output Port 2

SYMBOL	LQFP	FBGA	TYPE	DESCRIPTION
TRING2	58	M10	O	Transmit Ring Output Port 2
RTIP2	60	M8	I	Receive Tip Input Port 2
RRING2	61	L8	I	Receive Ring Input Port 2
TTIP3	64	N10	O	Transmit Tip Output Port 3
TRING3	63	P10	O	Transmit Ring Output Port 3
RTIP3	67	P8	I	Receive Tip Input Port 3
RRING3	66	N8	I	Receive Ring Input Port 3
TTIP4	117	B10	O	Transmit Tip Output Port 4
TRING4	118	A10	O	Transmit Ring Output Port 4
RTIP4	120	A8	I	Receive Tip Input Port 4
RRING4	121	B8	I	Receive Ring Input Port 4
TTIP5	124	D10	O	Transmit Tip Output Port 5
TRING5	123	C10	O	Transmit Ring Output Port 5
RTIP5	127	C8	I	Receive Tip Input Port 5
RRING5	126	D8	I	Receive Ring Input Port 5
TTIP6	129	D5	O	Transmit Tip Output Port 6
TRING6	130	C5	O	Transmit Ring Output Port 6
RTIP6	132	C7	I	Receive Tip Input Port 6
RRING6	133	D7	I	Receive Ring Input Port 6
TTIP7	136	B5	O	Transmit Tip Output Port 7
TRING7	135	A5	O	Transmit Ring Output Port 7
RTIP7	139	A7	I	Receive Tip Input Port 7
RRING7	138	B7	I	Receive Ring Input Port 7

3.8 JTAG Test Interface

SYMBOL	LQFP	FBGA	TYPE	DESCRIPTION
$\overline{\text{TRST}}$	95	G12	I	JTAG Reset This active Low input resets the JTAG controller. This input is pulled up internally and may be left as a NC when not used.
TMS	96	F11	I	JTAG Test Mode Select Input This input enables the JTAG serial port when active High. This input is sampled on the rising edge of TCK. This input is pulled up internally and may be left as a NC when not used.
TCK	97	F14	I	JTAG Test Clock Data on TDI is valid on the rising edge of TCK. Data on TDO is valid on the falling edge of TCK. When TCK is stopped high or low, the contents of all JTAG registers remain unchanged. Tie pin low through a 10 k Ω resistor when not used.
TDO	98	F13	O	JTAG Test Data Output JTAG test data is shifted out of the device on this pin. Data is output on the falling edge of TCK. Leave as NC when not used.
TDI	99	F12	I	JTAG Test Data Input JTAG test data is shifted into the device using this pin. The pin is sampled on the rising edge of TCK. TDI is pulled up internally and may be left as a NC when not used.

3.9 Miscellaneous

SYMBOL	LQFP	FBGA	TYPE	DESCRIPTION
REF	94	H13	I	Reference Input This pin must be tied to ground through 13.3 k Ω 1% resistor. This pin is used to set the internal current level.

4. OPERATION

The CS61880 is a full featured line interface unit for up to eight E1 75 Ω or E1 120 Ω lines. The device provides an interface to twisted pair or co-axial media. A matched impedance technique is employed that reduces power and eliminates the need for matching resistors. As a result, the device can interface directly to the line through a transformer without the need for matching resistors on the transmit side. The receive side uses the same resistor values for all E1 settings.

5. POWER-UP

On power-up, the device is held in a static state until the power supply achieves approximately 70% of the power supply voltage. Once the power supply threshold is passed, the analog circuitry is calibrated, the control registers are reset to their default settings, and the various internal state machines are reset. The reset/calibration process completes in about 30 ms.

6. MASTER CLOCK

The CS61880 requires a 2.048 MHz reference clock with a minimum accuracy of ± 100 ppm. This clock may be supplied from internal system timing or a CMOS crystal oscillator and input to the MCLK pin.

The receiver uses MCLK as a reference for clock recovery, jitter attenuation, and the generation of RCLK during LOS. The transmitter uses MCLK as the transmit timing reference during a blue alarm transmit all ones condition. In addition, MCLK provides the reference timing for wait state generation.

In systems with a jittered transmit clock, MCLK should not be tied to the transmit clock, a separate crystal oscillator should drive the reference clock input. Any jitter present on the reference clock will not be filtered by the jitter attenuator and can cause the CS61880 to operate incorrectly.

7. G.772 MONITORING

The receive path of channel zero of the CS61880 can be used to monitor the receive or transmit paths of any of the other channels. The signal to be monitored is multiplexed to channel zero through the G.772 Multiplexer. The multiplexer and channel zero then form a G.772 compliant digital Protected Monitoring Point (PMP). When the PMP is connected to the channel, the attenuation in the signal path is negligible across the signal band. The signal can be observed using RPOS, RNEG, and RCLK of channel zero or by putting channel zero in remote loop-back, the signal can be observed on TTIP and TRING of channel zero.

The G.772 monitoring function is available during both host mode and hardware mode operation. In host modes, individual channels are selected for monitoring via the **Performance Monitor Register (0Bh)** (See Section 14.12 on page 36). In hardware mode, individual channels are selected through the A3:A0 pins (Refer to Table 6 below for address settings).

Table 6. G.772 Address Selection

Address [A3:A0]	Channel Selection
0000	Monitoring Disabled
0001	Receiver Channel # 1
0010	Receiver Channel # 2
0011	Receiver Channel # 3
0100	Receiver Channel # 4
0101	Receiver Channel # 5
0110	Receiver Channel # 6
0111	Receiver Channel # 7
1000	Monitoring Disabled
1001	Transmitter Channel # 1
1010	Transmitter Channel # 2
1011	Transmitter Channel # 3
1100	Transmitter Channel # 4
1101	Transmitter Channel # 5
1110	Transmitter Channel # 6
1111	Transmitter Channel # 7

NOTE: In hardware mode the A4 pin must be tied low at all times.

8. BUILDING INTEGRATED TIMING SYSTEMS (BITS) CLOCK MODE

This mode is used to enable one or more channels as a stand-alone timing recovery unit used for G.703 Clock Recovery.

In hardware mode, BITS Clock mode is selected by pulling the MUX pin “HIGH”. This enables only channel zero as a stand-alone timing recovery unit, no other channel can be used as a timing recovery unit.

In host mode, each channel can be setup as an independent G.703 timing recovery unit, through the **Bits Clock Enable Register (1Eh)** (See Section 14.31 on page 40), setting the desired bit to “1” enables BITS Clock mode for that channel. The following diagrams show how the BITS clock function operates.

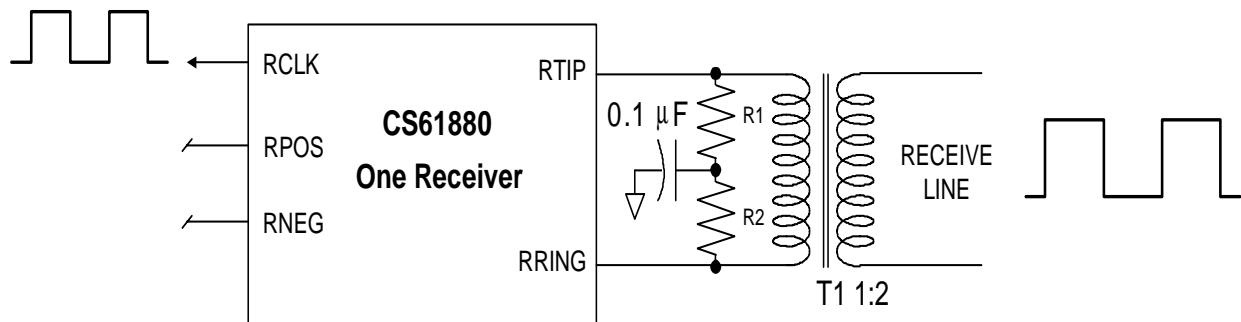

Figure 3. G.703 BITS Clock Mode in NRZ Mode

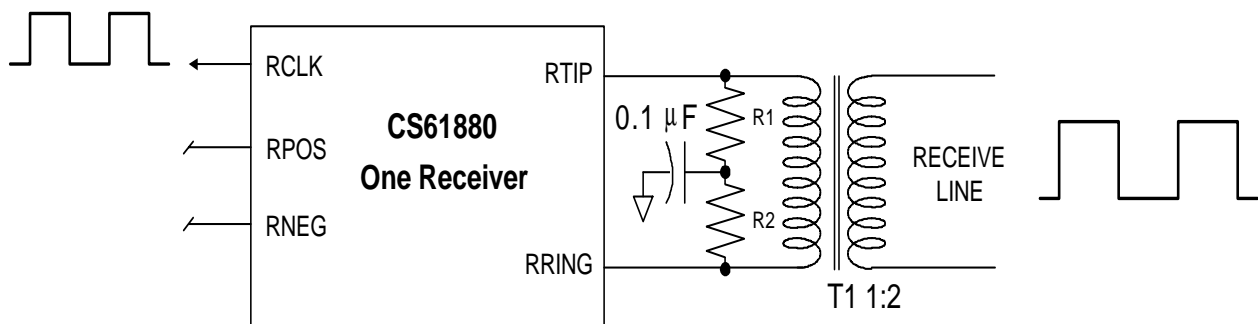

Figure 4. G.703 BITS Clock Mode in RZ Mode

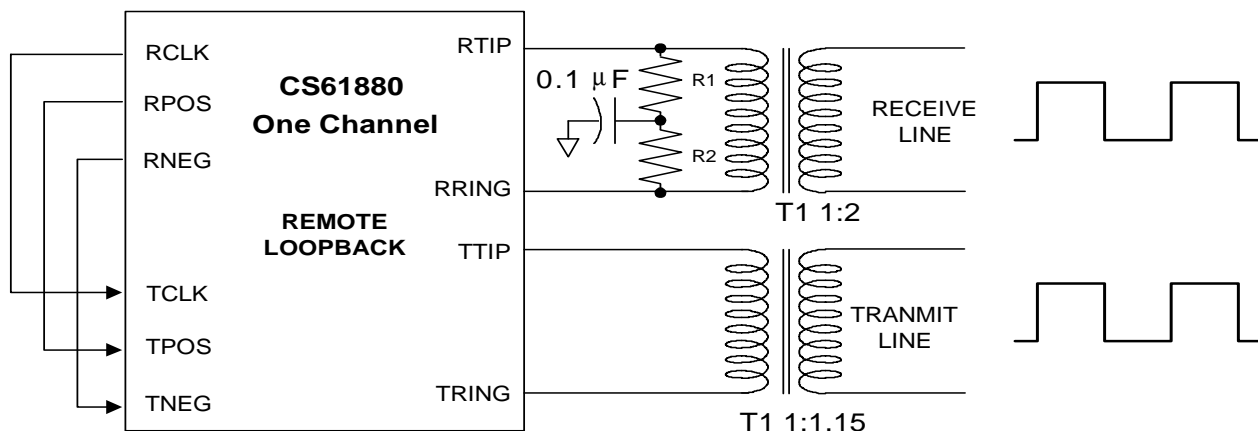

Figure 5. G.703 BITS Clock Mode in Remote Loopback

9. TRANSMITTER

The CS61880 contains eight identical transmitters that each use a low power matched impedance driver to eliminate the need for external load matching resistors, while providing superior return loss. As a result, the TTIP/TRING outputs can be connected directly to the transformer allowing one hardware circuit for E1 120 Ω , and E1 75 Ω applications.

Digital transmit data and clock are input into the CS61880 through the TPOS/TDATA, TNEG and TCLK input pins. These pins accept data in one of three formats: unipolar, bipolar, or RZ. In either unipolar or bipolar mode, the CS61880 internally generates a pulse shape compliant to the G.703 mask for E1 (Refer to Figure 6). The pulse shaping applied to the transmit data can be selected in hardware mode or in host mode.

In hardware mode, the line impedance (75 Ω or 120 Ω) and which prestored pulse shape to transmit (75 Ω or 120 Ω) is selected via the CBLSEL pin for all eight transmitters.

In host mode, each channel is configured independently by writing to the **Line Length Channel ID Register (10h)** (See Section 14.17 on page 38), then writing the desired line length settings to the LEN[3:0] bits in the **Line Length Data Register (11h)** (See Section 14.18 on page 38). The LEN bits select the pulse shape and line impedance of the addressed channel. In host mode, the CBLSEL pin is not used.

NOTE: If one channel is configured for E1 75 Ω mode, another channel can be configured for E1 120 Ω mode at the same time. This operation is only allowed in host mode.

The CS61880 also allows the user to customize the transmit pulse shapes to compensate for non-standard cables, transformers, or protection circuitry. For further information on the AWG Refer to **Arbitrary Waveform Generator** (See Section 15 on page 42).

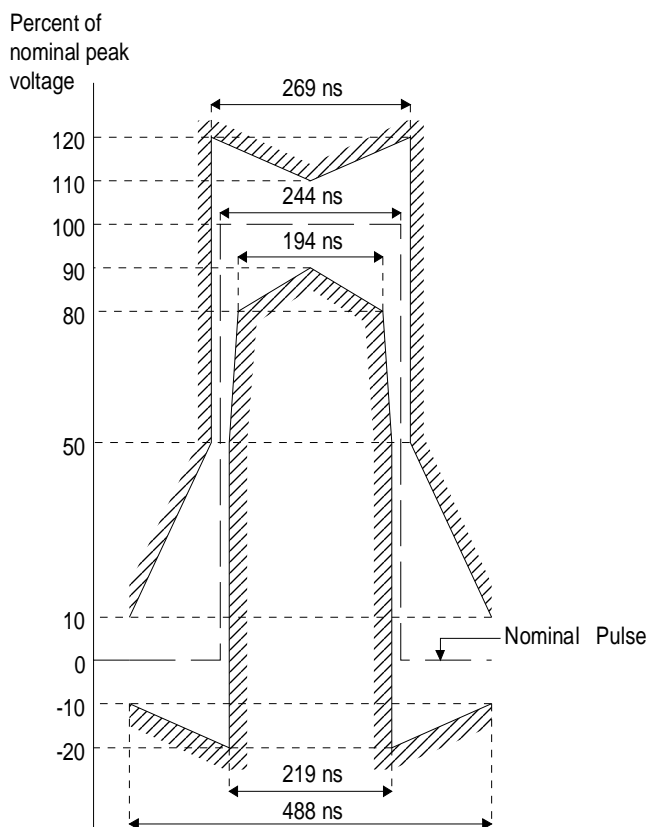

Figure 6. Pulse Mask at E1 Interface

For more information on the host mode registers refer to **Register Descriptions** (See Section 14 on page 35).

9.1 Bipolar Mode

Bipolar mode provides transparent operation for applications in which the line coding function is performed by an external framing device. In this mode, the falling edge of TCLK samples NRZ data on TPOS/TNEG for transmission on TTIP/TRING.

9.2 Unipolar Mode

In unipolar mode, the CS61880 is configured such that transmit data is encoded using HDB3, or AMI line codes. This mode is activated by holding

TNEG/UBS “High” for more than 16 TCLK cycles. Transmit data is input to the part via the TPOS/TDATA pin on the falling edge of TCLK. When operating the part in hardware mode, the CODEN pin is used to select between HDB3 or AMI encoding. During host mode operation, the line coding is selected via the **Line Length Channel ID Register (10h)** (See Section 14.17 on page 38).

NOTE: The encoders/decoders are selected for all eight channels in both hardware and host mode.

9.3 RZ Mode

In RZ mode, the internal pulse shape circuitry is bypassed and RZ data driven into TPOS/TNEG is transmitted on TTIP/TRING. In this mode, the pulse width of the transmitter output is determined by the width of the RZ signal input to TPOS/TNEG pins. This mode is entered when MCLK is inactive and TCLK is held “High” for at least 12 μ s.

9.4 Transmitter Powerdown / High-Z

The transmitters can be forced into a high impedance, low power state by holding TCLK of the appropriate channel low for at least 12 μ s or 140 MCLK cycles. In hardware and host mode, the TXOE pin forces all eight transmitters into a high impedance state within 1 μ s.

In host mode, each transmitter is individually controllable using the **Output Disable Register (12h)** (See Section 14.19 on page 38). The TXOE pin can be used in host mode, but does not effect the contents of the Output Enable Register. This feature is useful in applications that require redundancy.

9.5 Transmit All Ones (TAOS)

When TAOS is activated, continuous ones are transmitted on TTIP/TRING using MCLK as the transmit timing reference. In this mode, the TPOS and TNEG inputs are ignored.

In hardware mode, TAOS is activated by pulling TCLK “High” for more than 16 MCLK cycles.

In host mode, TAOS is generated for a particular channel by asserting the associated bit in the **TAOS Enable Register (03h)** (See Section 14.4 on page 35).

Since MCLK is the reference clock, it should be of adequate stability.

9.6 Automatic TAOS

While a given channel is in the LOS condition, if the corresponding bit in the **Automatic TAOS Register (0Eh)** (See Section 14.15 on page 37) is set, the device will drive that channel’s TTIP and TRING with the all ones pattern. This function is only available in host mode. Refer to **Loss-of-Signal (LOS)** (See Section 10.5 on page 27).

9.7 Driver Failure Monitor

In host mode, the Driver Failure Monitor (DFM) function monitors the output of each channel and sets a bit in the **DFM Status Register (05h)** (See Section 14.6 on page 35) if a secondary short circuit is detected between TTIP and TRING. This generates an interrupt if the respective bit in the **DFM Interrupt Enable Register (07h)** (See Section 14.8 on page 36) is also set. Any change in the **DFM Status Register (05h)** (See Section 14.6 on page 35) will result in the corresponding bit in the **DFM Interrupt Status Register (09h)** (See Section 14.10 on page 36) being set. The interrupt is cleared by reading the **DFM Interrupt Status Register (09h)** (See Section 14.10 on page 36).

9.8 Driver Short Circuit Protection

The CS61880 provides driver short circuit protection when current on the secondary exceeds 50 mA RMS.

10. RECEIVER

The CS61880 contains eight identical receivers that utilize an internal matched impedance technique that provides for the use of a common set of external components for 120 Ω (E1), and 75 Ω (E1) operation (Refer to Figure 16 on page 50). This feature enables the use of a one stuffing option for all E1 line impedances. The receivers can also be configured to use different external resistors to match the line impedance for E1 75 Ω or E1 120 Ω modes (Refer to Figure 17 on page 51).

In hardware mode, the CBLSEL pin is used to select the proper line impedance (75 Ω or 120 Ω) and either internal or external line impedance matching mode.

In host mode, each receiver's line impedance is selected individually via the **Line Length Channel ID Register (10h)** (See Section 14.17 on page 38) and bits[3:0] and the LEN[3:0] bits of the **Line Length Data Register (11h)** (See Section 14.18 on page 38). The INT_EXTB bit of the **Line Length Data Register (11h)** (See Section 14.18 on page 38) is used to select between internal or external line impedance matching modes for all eight channels. The CBLSEL pin is not used in host mode.

The CS61880 receiver provides all of the circuitry to recover both data and clock from the data signal input on RTIP and RRING. The matched impedance receiver is capable of recovering signals with 12 dB of attenuation (referenced to 2.37 V or 3.0 V nominal) while providing superior return loss. In addition, the timing recovery circuit along with the jitter attenuator provide jitter tolerance that far exceeds jitter specifications (Refer to Figure 19 on page 57).

The recovered data and clock are output from the CS61880 on the RPOS/RDATA, RNEG and RCLK pins. These pins output the data in one of three formats: bipolar, unipolar, or RZ. The CLKE

pin is used to configure RPOS/RDATA and RNEG, so that data is valid on either the rising or falling edge of RCLK. Refer to the CLKE pin description on page 13 for CLKE settings.

10.1 Bipolar Output Mode

Bipolar mode provides a transparent clock/data recovery for applications in which the line decoding is performed by an external framing device. The recovered clock and data are output on RCLK, RNEG and RPOS.

10.2 Unipolar Output Mode

In unipolar mode, the CS61880 decodes the recovered data with either HDB3 or AMI line decoding. The decoded data is output on the RPOS/RDATA pin. When bipolar violations are detected by the decoder, the RNEG/BPV pin is asserted "high". This pin is driven "high" for one RCLK period for every bipolar violation that is not part of the zero substitution rules. Unipolar mode is entered by holding the TNEG pin "high" for more than 16 TCLK cycles.

In hardware mode, the HDB3/AMI encoding/decoding is activated via the CODEN pin.

In host mode, Bit 4 of the **Line Length Channel ID Register (10h)** (See Section 14.17 on page 38) is used to select the encoding/decoding for all channels.

10.3 RZ Output Mode

In this mode the RTIP and RRING inputs are sliced to data values that are output on RPOS and RNEG pins. This mode is used in applications that have clock recovery circuitry external to the device. To support external clock recovery, the RPOS and RNEG outputs are XORed and output as RCLK. This mode is entered when MCLK is tied high. The polarity of the RPOS/RNEG data are controlled by the CLKE pin. Refer to the CLKE pin description on page 13 for CLKE settings.

10.4 Receiver Powerdown/High-Z

All eight receivers are powered down when MCLK is held low. In addition, this will force the RCLK, RPOS/RDATA and RNEG outputs into a high impedance state.

10.5 Loss-of-Signal (LOS)

The CS61880 makes use of both analog and digital LOS detection circuitry that is compliant to the latest specifications. The LOS condition can be set to either ITU G.775 or ETSI 300 233. This change is done through the **LOS/AIS Mode Enable Register (0Dh)** (See Section 14.14 on page 37).

The LOS detector increments a counter each time a zero is received, and resets the counter each time a one “mark” is received. Depending on LOS detection mode, the LOS signal is set when a certain number of consecutive zeros are received. In Clock/Data recovery mode, this forces the recovered clock to be replaced by MCLK at the RCLK output. In addition the RPOS/RDATA and RNEG outputs remain active for the length of the LOS period, except when local and analog loopbacks are enabled. Upon exiting LOS, the recovered clock replaces MCLK on the RCLK output. In Data recovery mode, RCLK is not replaced by MCLK when LOS is active. The LOS detection modes are summarized below.

NOTE: G.775 and ETSI 300 233 are both available in host mode, but in hardware mode only ETSI 300 233 is available.

ITU G.775 (E1 Mode Only) - LOS is declared when the received signal level is less than 200 mV for 32 consecutive pulse periods (typical). The device exits LOS when the received signal achieves 12.5% ones density with no more than 15 consecu-

tive zeros in a 32-bit sliding window and the signal level exceeds 250 mV.

ETSI 300 233 (E1 Host Mode Only) - The LOS indicator becomes active when the receive signal level drops below 200 mV for more than 2048 pulse periods (1 ms). The channel exits the LOS state when the input signal exceeds 250 mV and has transitions for more than 32 pulse periods (16 μ s). This LOS detection method can only be selected while in host mode.

During host mode operation, LOS is reported in the LOS Status Monitor Register. Both the LOS pins and the register bits reflect LOS status in host mode operation. The LOS pins and status bits are set high (indicating loss of signal) during reset, power-up, or channel powered-down.

10.6 Alarm Indication Signal (AIS)

The CS61880 detects all ones alarm condition per the relevant ITU, and ETSI specifications. In general, AIS is indicated when the one’s density of the receive signal exceeds that dictated by the relevant specification. This feature is only available in host mode (Refer to **LOS/AIS Mode Enable Register (0Dh)** (See Section 14.14 on page 37)).

ITU G.775 AIS (E1 Mode) - The AIS condition is declared when less than 3 zeros are received within two consecutive 512-bit windows. The AIS condition is cleared when 3 or more zeros are received in two consecutive 512-bit windows.

ETSI 300 233 (E1 Mode) - The AIS condition is declared when less than 3 zeros are received in a 512-bit window. The AIS condition is cleared when a 512-bit window is received containing 3 or more zeros.

11. JITTER ATTENUATOR

The CS61880 internal jitter attenuators can be switched into either the receive or transmit paths. Alternatively, it can be removed from both paths to reduce the propagation delay.

During Hardware mode operation, the location of the jitter attenuator for all eight channels are controlled by the JASEL pin (Refer to Table 7 for pin configurations). The jitter attenuator's FIFO length and corner frequency, can not be changed in hardware mode. The FIFO length and corner frequency are set to 32 bits and 1.25 Hz.

Table 7. Jitter Attenuator Configurations

PIN STATE	JITTER ATTENUATOR POSITON
LOW	Transmit Path
HIGH	Receive Path
OPEN	Disabled

During host mode operation, the location of the jitter attenuator for all eight channels are set by bits 0 and 1 in the **Line Length Channel ID Register (10h)** (See Section 14.17 on page 38). This register

(0Fh) also configures the jitter attenuator's FIFO length (bit 3) and corner frequency (bit 2).

The attenuator consists of a 64-bit FIFO, a narrow-band monolithic PLL, and control logic. The jitter attenuator requires no external crystal. Signal jitter is absorbed in the FIFO which is designed to neither overflow nor underflow.

If overflow or underflow is imminent, the jitter transfer function is altered to ensure that no bit-errors occur. A configuration option is provided to reduce the jitter attenuator FIFO length from 64 bits to 32 bits in order to reduce propagation delay. The jitter attenuator -3 dB knee frequency depends on the settings of the Jitter Attenuator FIFO length and the Jitter Attenuator Corner Frequency, bits 2 and 3, in the **Line Length Channel ID Register (10h)** (See Section 14.17 on page 38)). Setting the lowest corner frequency guarantees jitter attenuation compliance to European specifications TBR 12/13 and ETS 300 011. The jitter attenuator is also compliant with ITU-T G.735, G.742, and G.783 (Refer to Figure 18 on page 56 and Figure 19 on page 57).

12. OPERATIONAL SUMMARY

A brief summary of the CS61880 operations in hardware and host mode is provided in Table 8.

Table 8. Operational Summary

MCLK	TCLK	LOOP	Receive Mode	Transmit Mode	Loopback
Active	Active	Open	RCLK/Data Recovery	Unipolar/Bipolar	Disabled
Active	Active	L	RCLK/Data Recovery	Unipolar/Bipolar	Remote Loopback
Active	Active	H	RCLK/Data Recovery	Unipolar/Bipolar	Analog Loopback
Active	L	X	RCLK/Data Recovery	Power Down	Disabled
Active	H	Open	RCLK/Data Recovery	TAOS	Disabled
Active	H	L	RCLK/Data Recovery	Unipolar/Bipolar	Remote Loopback
Active	H	H	RCLK/Data Recovery	TAOS	Analog Loopback
L	Active	X	Power Down	Unipolar/Bipolar	Disabled
L	H	X	Power Down	RZ Data	Disabled
L	L	X	Power Down	Power Down	Disabled
H	Active	Open	Data Recovery	Unipolar/Bipolar	Disabled
H	Active	L	Data Recovery	RZ Data	Remote Loopback
H	Active	H	Data Recovery	Unipolar/Bipolar	Analog Loopback
H	L	Open	Data Recovery	Power Down	Disabled
H	L	L	Data Recovery	RZ Data	Remote Loopback
H	L	H	Data Recovery	Power Down	Disabled
H	H	Open	Data Recovery	RZ Data	Disabled
H	H	L	Data Recovery	RZ Data	Remote Loopback
H	H	H	Data Recovery	RZ Data	Analog Loopback

12.1 Loopbacks

The CS61880 provides three loopback modes for each port. Analog Loopback connects the transmit signal on TTIP and TRING to RTIP and RRING. Digital Loopback Connects the output of the Encoder to the input of the Decoder (through the Jitter Attenuator if enabled). Remote Loopback connects the output of the Clock and Data Recovery block to the input of the Pulse Shaper block. (Refer to detailed descriptions below.) In hardware mode, the LOOP[7:0] pins are used to activate Analog or Remote loopback for each channel. In host mode, the Analog, Digital and Remote Loopback registers are used to enable these functions (Refer to the **Analog Loopback Register (01h)** (See Section 14.2 on page 35), **Remote Loopback Register (02h)** (See Section 14.3 on page 35), and **Digital Loopback Reset Register (0Ch)** (See Section 14.13 on page 36).

12.2 Analog Loopback

In Analog Loopback, the output of the TTIP/TRING driver is internally connected to the input of the RTIP/RRING receiver so that the data on TPOS/TNEG and TCLK appears on the RPOS/RNEG and RCLK outputs. In this mode the RTIP and RRING inputs are ignored. Refer to Figure 7 on page 30. In hardware mode, Analog Loopback is selected by driving LOOP[7:0] high. In host mode, Analog Loopback is selected for a given channel using the appropriate bit in the **Analog Loopback Register (01h)** (See Section 14.2 on page 35).

NOTE: The simultaneous selection of Analog and Remote loopback modes is not valid. A TAOS request overrides the data on TPOS and TNEG during Analog Loopback. Refer to Figure 8 on page 30.

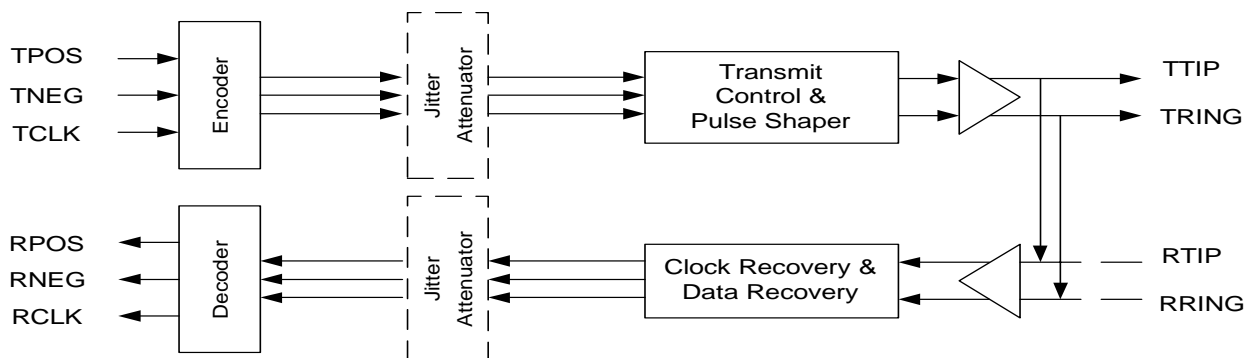

Figure 7. Analog Loopback Block Diagram

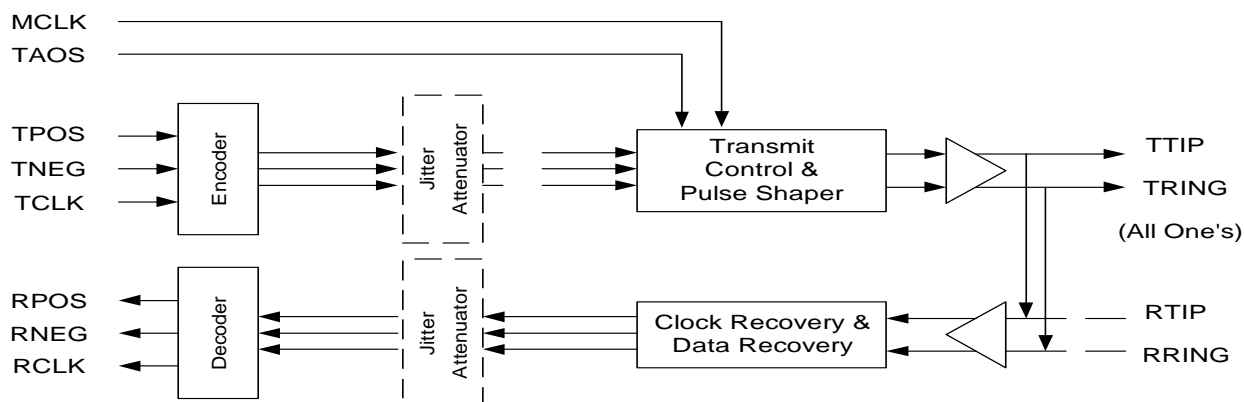

Figure 8. Analog Loopback with TAOS Block Diagram

12.3 Digital Loopback

Digital Loopback causes the TCLK, TPOS, and TNEG (or TDATA) inputs to be looped back through the jitter attenuator (if enabled) to the RCLK, RPOS, and RNEG (or RDATA) outputs. The receive line interface is ignored, but data at TPOS and TNEG (or TDATA) continues to be transmitted to the line interface at TTIP and TRING (Refer to Figure 9 on page 31).

Digital Loopback is only available during host mode. It is selected using the appropriate bit in the **Digital Loopback Reset Register (0Ch)** (See Section 14.13 on page 36).

NOTE: TAOS can also be used during the Digital Loopback operation for the selected channel (Refer to Figure 10 on page 31).

12.4 Remote Loopback

In remote loopback, the RPOS/RNEG and RCLK outputs are internally input to the transmit circuits for output on TTIP/TRING. In this mode the TCLK, TPOS and TNEG inputs are ignored. (Refer to Figure 11 on page 31). In hardware mode, Remote Loopback is selected by driving the LOOP pin for a certain channel low. In host mode, Remote Loopback is selected for a given channel by writing a one to the appropriate bit in the **Remote Loopback Register (02h)** (See Section 14.3 on page 35).

NOTE: In hardware mode, Remote Loopback overrides TAOS for the selected channel. In host mode, TAOS overrides Remote Loopback.

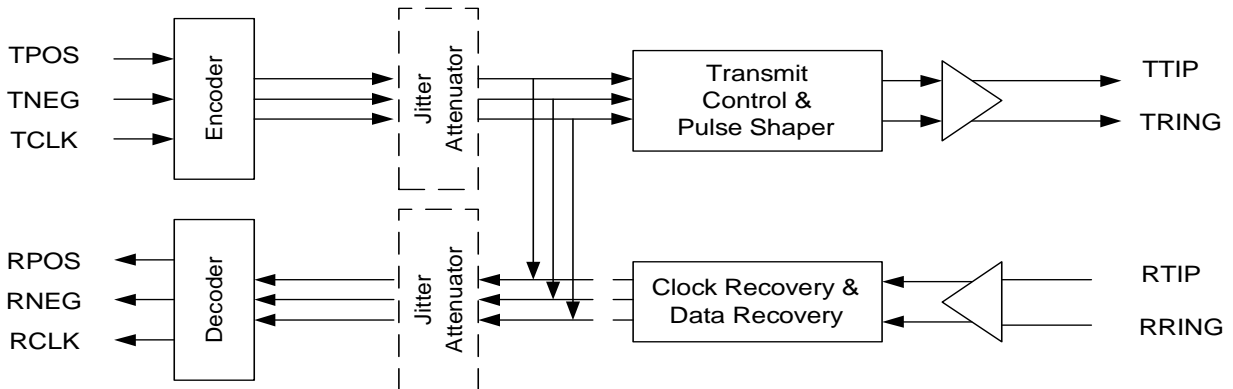

Figure 9. Digital Loopback Block Diagram

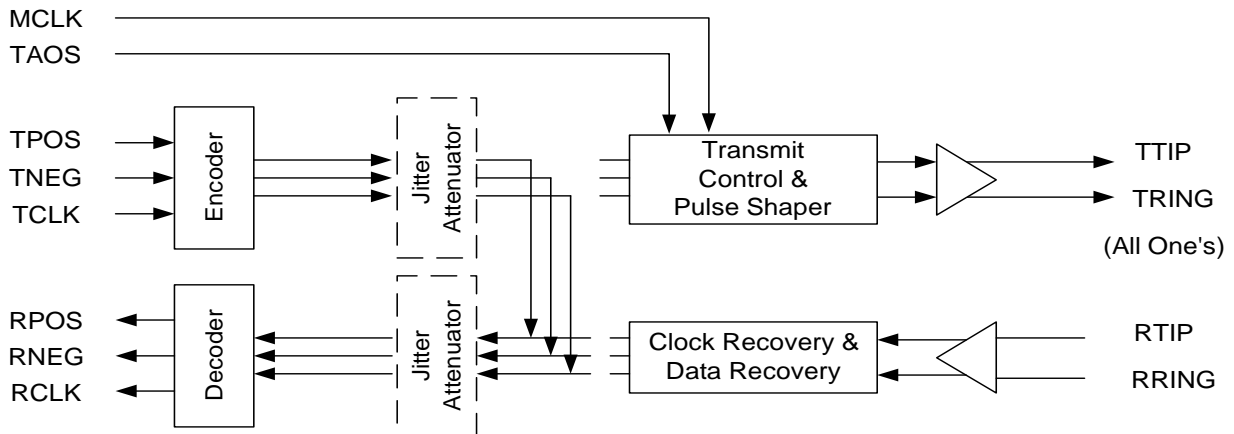

Figure 10. Digital Loopback with TAOS

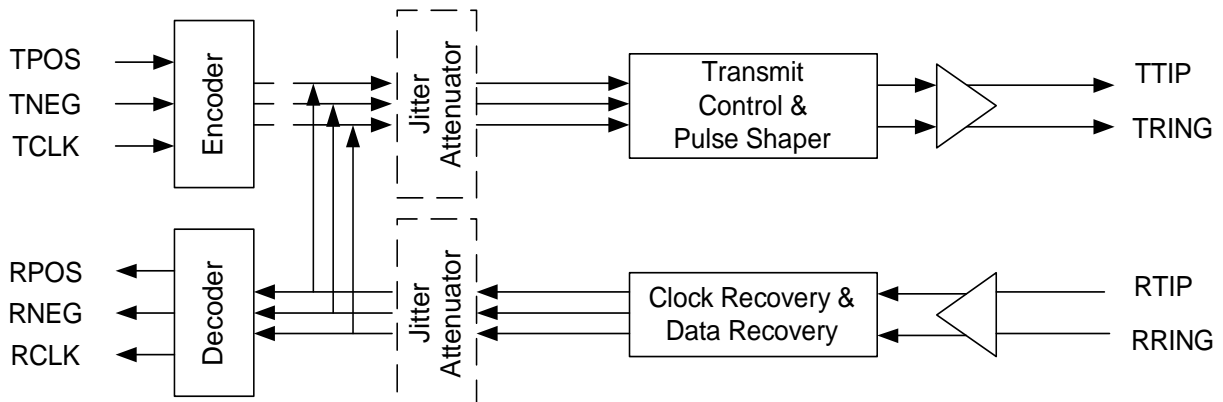

Figure 11. Remote Loopback Block Diagram

13. HOST MODE

Host mode allows the CS61880 to be configured and monitored using an internal register set. (Refer to Table 1, “Operation Mode Selection,” on page 10). The term, “Host mode” applies to both Parallel Host and Serial Host modes.

All of the internal registers are available in both Serial and Parallel Host mode; the only difference is in the functions of the interface pins, which are described in Table 9 on page 32.

Serial port operation is compatible with the serial ports of most microcontrollers. Parallel port operation can be configured to be compatible with 8-bit microcontrollers from Motorola or Intel, with both multiplexed or non-multiplexed address/data buses. (Refer to Table 10 on page 34 for host mode registers).

13.1 SOFTWARE RESET

A software reset can be forced by writing the **Software Reset Register (0Ah)** (See Section 14.11 on page 36). A software reset initializes all registers to their default settings and initializes all internal state machines.

13.2 Serial Port Operation

Serial port host mode operation is selected when the MODE pin is left open or set to VCC/2. In this mode, the CS61880 register set is accessed by setting the chip select (\overline{CS}) pin low and communicating over the SDI, SDO, and SCLK pins. Timing over the serial port is independent of the transmit and receive system timing. Figure 12 illustrates the format of serial port data transfers.

A read or write is initiated by writing an address/command byte (ACB) to SDI. Only the ADR0-ADR4 bits are valid; bits ADR5-ADR6 are do not cares. During a read cycle, the register data addressed by the ACB is output on SDO on the next eight SCLK clock cycles. During a write cycle, the data byte immediately follows the ACB.

Data is written to and read from the serial port in LSB first format. When writing to the port, SDI data is sampled by the device on the rising edge of SCLK. The valid clock edge of the data on SDO is controlled by the CLKE pin. When CLKE is low, data on SDO is valid on the falling edge of SCLK. When CLKE is high, data on SDO is valid on the raising edge of SCLK. The SDO pin is High-Z when not transmitting. If the host processor has a

Table 9. Host Control Signal Descriptions

HOST CONTROL SIGNAL DESCRIPTIONS				
PIN NAME	PIN #	HARDWARE	SERIAL	PARALLEL
MODE	11	LOW	VDD/2	HIGH
MUX	43	BITSEN0	-	MUX
CODEN/MOT/INTL	88	CODEN	-	MOT/INTL
ADDR [4]	12	GND	-	ADDR[4]
ADDR[3:0]	13-16	ADDR[3:0]	-	ADDR [3:0]
LOOP[7:0], DATA[7:0]	28-21	LOOP[7:0]	-	DATA[7:0]
\overline{INT}	82	Pulled Up	\overline{INT}	\overline{INT}
SDO/ACK/RDY	83	NC	SDO	ACK/RDY
SDI/DS/WR	84	GND	SDI	DS/WR
R/W/RD	85	GND	-	R/W/RD
SCLK/AS/ALE	86	GND	SCLK	AS/ALE
JASEL/CS	87	JASEL	CS	CS

bidirectional I/O port, SDI and SDO may be tied together.

As illustrated in Figure 12, the ACB consists of a R/\overline{W} bit, address field, and two reserved bits. The R/\overline{W} bit specifies if the current register access is a read ($R/\overline{W} = 1$) or a write ($R/\overline{W} = 0$) operation. The address field specifies the register address from 0x00 to 0x1f.

13.3 Parallel Port Operation

Parallel port host mode operation is selected when the MODE pin is high. In this mode, the CS61880 register set is accessed using an 8-bit, multiplexed bidirectional address/data bus D[7:0]. Timing over the parallel port is independent of the transmit and receive system timing.

The device is compatible with both Intel and Motorola bus formats. The Intel bus format is selected when the INTL/ \overline{MOT} pin is high and the Motorola bus format is selected when the INTL/ \overline{MOT} pin is low. In either mode, the interface can have the address and data multiplexed over the same 8-bit bus or on separate busses. This operation is controlled with the MUX pin; MUX = 1 means that the parallel port has its address and data multiplexed over the same bus; MUX = 0 defines a non-multiplexed bus. The timing for the different modes are shown

in Figure 28, Figure 26, Figure 25, Figure 27, Figure 29, Figure 30, Figure 31 and Figure 32.

Multiplexed Intel and Motorola modes are shown in Figure 28, Figure 26, Figure 25 and Figure 27. A read or write is initiated by writing an address byte to D[7:0]. The device latches the address on the falling edge of $ALE(\overline{AS})$. During a read cycle, the register data is output during the later portion of the \overline{RD} or \overline{DS} pulses. The read cycle is terminated and the bus returns to a high impedance state as \overline{RD} transitions high in Intel timing or \overline{DS} transitions high in Motorola timing. During a write cycle, valid write data must be present and held stable during the \overline{WR} or \overline{DS} pulses.

Non-multiplexed Intel and Motorola modes are shown in Figure 29, Figure 30, Figure 32 and Figure 31. The \overline{CS} pin initiates the cycle, followed by the \overline{DS} , \overline{RD} or \overline{WR} pin. Data is latched into or out of the part using the rising edge of the \overline{DS} , \overline{WR} or \overline{RD} pin. Raising \overline{CS} ends the cycle.

In Intel mode, the RDY output pin is normally in a high impedance state; it pulses low once to acknowledge that the chip has been selected, and high again to acknowledge that data has been written or read. In Motorola mode, the \overline{ACK} pin performs a similar function; it drives high to indicate that the address has been received by the part, and goes low again to indicate that data has been written or read.

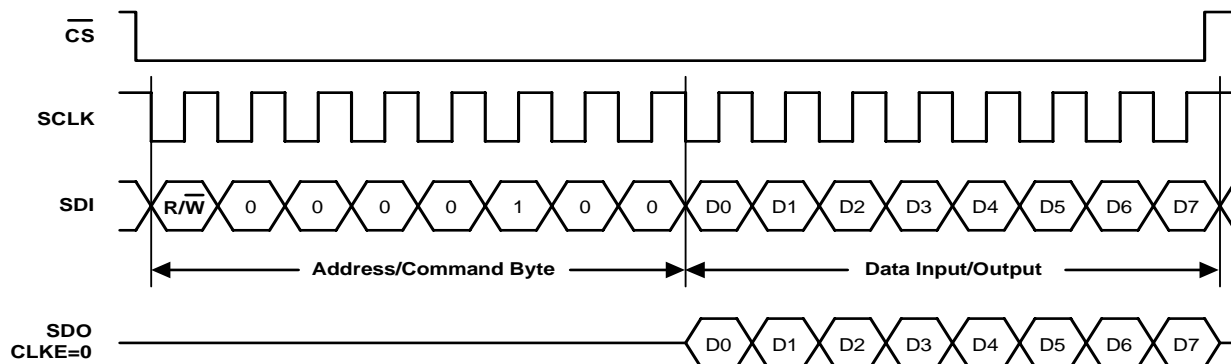

Figure 12. Serial Read/Write Format (SPOL = 0)

13.4 Register Set

The register set available during host mode operations are presented in Table 10. While the upper

three bits of the parallel address are don't cares on the CS61880, they should be set to zero for proper operation.

Table 10. Host Mode Register Set

REGISTERS			BITS							
ADDR	NAME	TYPE	7	6	5	4	3	2	1	0
00h	Revision/IDCODE	R	IDCODE Refer to <i>Device ID Register (IDR)</i> on page 47							
01h	Analog Loopback	R/W	ALBK 7	ALBK 6	ALBK 5	ALBK 4	ALBK 3	ALBK 2	ALBK 1	ALBK 0
02h	Remote Loopback	R/W	RLBK 7	RLBK 6	RLBK 5	RLBK 4	RLBK 3	RLBK 2	RLBK 1	RLBK 0
03h	TAOS Enable	R/W	TAOE 7	TAOE 6	TAOE 5	TAOE 4	TAOE 3	TAOE 2	TAOE 1	TAOE 0
04h	LOS Status	R	LOSS 7	LOSS 6	LOSS 5	LOSS 4	LOSS 3	LOSS 2	LOSS 1	LOSS 0
05h	DFM Status	R	DFMS 7	DFMS 6	DFMS 5	DFMS 4	DFMS 3	DFMS 2	DFMS 1	DFMS 0
06h	LOS Interrupt Enable	R/W	LOSE 7	LOSE 6	LOSE 5	LOSE 4	LOSE 3	LOSE 2	LOSE 1	LOSE 0
07h	DFM Interrupt Enable	R/W	DFME 7	DFME 6	DFME 5	DFME 4	DFME 3	DFME 2	DFME 1	DFME 0
08h	LOS Interrupt Status	R	LOSI 7	LOSI 6	LOSI 5	LOSI 4	LOSI 3	LOSI 2	LOSI 1	LOSI 0
09h	DFM Interrupt Status	R	DFMI 7	DFMI 6	DFMI 5	DFMI 4	DFMI 3	DFMI 2	DFMI 1	DFMI 0
0Ah	Software Reset	R/W	SRES 7	SRES 6	SRES 5	SRES 4	SRES 3	SRES 2	SRES 1	SRES 0
0Bh	Performance Monitor	R/W	RSVD	RSVD	RSVD	RSVD	A3	A2	A1	A0
0Ch	Digital Loopback	R/W	DLBK 7	DLBK 6	DLBK 5	DLBK 4	DLBK 3	DLBK 2	DLBK 1	DLBK 0
0Dh	LOS/AIS Mode Enable	R/W	LAME 7	LAME 6	LAME 5	LAME 4	LAME 3	LAME 2	LAME 1	LAME 0
0Eh	Automatic TAOS	R/W	ATAO 7	ATAO 6	ATAO 5	ATAO 4	ATAO 3	ATAO 2	ATAO 1	ATAO 0
0Fh	Global Control	R/W	AI	Raisen	RSVD	Coden	FIFO	JACF	JASEL [1:0]	
10h	Line Length Channel ID	R/W	RSVD	RSVD	RSVD	RSVD	RSVD	Channel ID		
11h	Line Length Data	R/W	RSVD	RSVD	RSVD	IN_EX	LEN[3:0]			
12h	Output Disable	R/W	OENB 7	OENB 6	OENB 5	OENB 4	OENB 3	OENB 2	OENB 1	OENB 0
13h	AIS Status	R	AISS 7	AISS 6	AISS 5	AISS 4	AISS 3	AISS 2	AISS 1	AISS 0
14h	AIS Interrupt Enable	R/W	AISE 7	AISE 6	AISE 5	AISE 4	AISE 3	AISE 2	AISE 1	AISE 0
15h	AIS Interrupt Status	R	AISI 7	AISI 6	AISI 5	AISI 4	AISI 3	AISI 2	AISI 1	AISI 0
16h	AWG Broadcast	R/W	AWGB 7	AWGB 6	AWGB 5	AWGB 4	AWGB 3	AWGB 2	AWGB 1	AWGB 0
17h	AWG Phase Address	R/W	Channel Address [2:0]			Phase Address [4:0]				
18h	AWG Phase Data	R/W	RSVD	Sample Data[6:0]						
19h	AWG Enable	R/W	AWGN 7	AWGN 6	AWGN 5	AWGN 4	AWGN 3	AWGN 2	AWGN 1	AWGN 0
1Ah	RESERVED	R/W	RSVD 7	RSVD 6	RSVD 5	RSVD 4	RSVD 3	RSVD 2	RSVD 1	RSVD 0
1Bh	RESERVED	R	RSVD 7	RSVD 6	RSVD 5	RSVD 4	RSVD 3	RSVD 2	RSVD 1	RSVD 0
1Ch	RESERVED	R/W	RSVD 7	RSVD 6	RSVD 5	RSVD 4	RSVD 3	RSVD 2	RSVD 1	RSVD 0
1Dh	RESERVED	R	RSVD 7	RSVD 6	RSVD 5	RSVD 4	RSVD 3	RSVD 2	RSVD 1	RSVD 0
1Eh	BITS Clock Enable	R/W	BITS 7	BITS 6	BITS 5	BITS 4	BITS 3	BITS 2	BITS 1	BITS 0
1Fh	RESERVED	R/W	RSVD 7	RSVD 6	RSVD 5	RSVD 4	RSVD 3	RSVD 2	RSVD 1	RSVD 0

14. REGISTER DESCRIPTIONS

14.1 Revision/IDcode Register (00h)

BIT	NAME	Description
[7:4]	REVI 7-4	Bits [7:4] are taken from the least-significant nibble of the Device IDCode, which are 0000. (Refer to Device ID Register (IDR) (See Section 16.3 on page 47).
[3:0]	REVI 3-0	Bits [3:0] are the revision bits from the JTAG IDCODE register, CS61880 Revision A = 0000. These bits are subject to change with the revision of the device (Refer to Device ID Register (IDR) (See Section 16.3 on page 47).

14.2 Analog Loopback Register (01h)

BIT	NAME	Description
[7:0]	ALBK 7-0	Enables analog loopbacks. A “1” in bit n enables the loopback for channel n. Refer to Analog Loopback (See Section 12.2 on page 29) for a complete explanation. Register bits default to 00h after power-up or reset.

14.3 Remote Loopback Register (02h)

BIT	NAME	Description
[7:0]	RLBK 7-0	Enables remote loopbacks. A “1” in bit n enables the loopback for channel n. Refer to HOST MODE (See Section 13 on page 32) for a complete explanation. Register bits default to 00h after power-up or reset.

14.4 TAOS Enable Register (03h)

BIT	NAME	Description
[7:0]	TAOE 7-0	A “1” in bit n of this register turns on the TAOS generator in channel n. Register bits default to 00h after power-up or reset.

14.5 LOS Status Register (04h)

BIT	NAME	Description
[7:0]	LOSS 7-0	Register bit n is read as “1” when LOS is detected on channel n. Register bits default to 00h after power-up or reset.

14.6 DFM Status Register (05h)

BIT	NAME	Description
[7:0]	DFMS 7-0	Driver Failure Monitor. The DFM will set bit n to “1” when it detects a short circuit in channel n. Register bits default to 00h after power-up or reset.

14.7 LOS Interrupt Enable Register (06h)

BIT	NAME	Description
[7:0]	LOSE 7-0	Any change in a LOS Status Register will cause the INT pin to go low if corresponding bit in this register is set to "1". Register bits default to 00h after power-up or reset.

14.8 DFM Interrupt Enable Register (07h)

BIT	NAME	Description
[7:0]	DFME 7-0	Enables interrupts for failures detected by the DFM. Any change in a DFM Status Register bit will cause an interrupt if the corresponding bit is set to "1" in this register. Register bits default to 00h after power-up or reset.

14.9 LOS Interrupt Status Register (08h)

BIT	NAME	Description
[7:0]	LOSI 7-0	Bit n of this register is set to "1" to indicate a status change in bit n of the LOS Status Register. The bits in this register indicate a change in status since the last cleared LOS interrupt. Register bits default to 00h after power-up or reset.

14.10 DFM Interrupt Status Register (09h)

BIT	NAME	Description
[7:0]	DFMI 7-0	Bit n of this register is set to "1" to indicate a status change in bit n of the DFM Status Register. The bits in this register indicate a change in status since the last cleared DFM interrupt. Register bits default to 00h after power-up or reset.

14.11 Software Reset Register (0Ah)

BIT	NAME	Description
[7:0]	SRES 7-0	Writing to this register initializes all registers to their default settings. Register bits default to 00h after power-up or reset.

14.12 Performance Monitor Register (0Bh)

BIT	NAME	Description
[7:4]	RSVD 7-4	RESERVED (These bits must be set to 0.)
[3:0]	A[3:0]	The G.772 Monitor is directed to a given channel based on the state of the four least significant bits of this register. Register bits default to 00h after power-up or reset. The following table shows the settings needed to select a specific channel's receiver or transmitter to perform G.772 monitoring. See Table 6 on page 22 for G.772 Monitor Settings.

14.13 Digital Loopback Reset Register (0Ch)

BIT	NAME	Description
[7:0]	DLBK 7-0	Setting register bit n to "1" enables the digital loopback for channel n. Refer to Digital Loopback (See Section 12.3 on page 30) for a complete explanation. Register bits default to 00h after power-up or reset.

14.14 LOS/AIS Mode Enable Register (0Dh)

BIT	NAME	Description
[7:0]	LAME 7-0	Setting bit n to “1” enables ETSI 300 233 compliant LOS/AIS for channel n; setting bit n to “0” enables ITU G.775 compliant LOS/AIS for channel n. Register bits default to 00h after power-up or reset.

14.15 Automatic TAOS Register (0Eh)

BIT	NAME	Description
[7:0]	ATAO 7-0	Setting bit n to “1” enables automatic TAOS generation on channel n when LOS is detected. Register bits default to 00h after power-up or reset.

14.16 Global Control Register (0Fh)

BIT	NAME	Description															
		This register is the global control for the AWG Auto-Increment, Automatic AIS insertion, encoding/decoding and the jitter attenuators location, FIFO length and corner frequency for all eight channels. Register bits default to 00h after power-up or reset.															
[7]	AWG Auto-Increment	The AWG Auto-Increment bit indicates whether to auto-increment the AWG Phase Address Register (17h) (See Section 14.24 on page 39) after each access. Thus, when this bit is set, the phase samples address portion of the address register increments after each read or write access. This bit must be set before any bit in the AWG Enable register is set, if this function is required.															
[6]	RAISEN	On LOS, this bit controls the automatic AIS insertion into all eight receiver paths. 0 = Disabled 1 = Enabled															
[5]	RSVD	RESERVED (This bit must be set to 0.)															
[4]	$\overline{\text{CODEN}}$	Line encoding/decoding Selection 0 = HDB3 1 = AMI															
[3]	FIFO LENGTH	Jitter Attenuator FIFO length Selection 0 = 32 bits 1 = 64 bits															
[2]	JACF	Jitter Attenuator Corner Frequency Selection 0 = 1.25 Hz 1 = 2.50 Hz															
[1:0]	JASEL [1:0]	These bits select the position of the Jitter Attenuator. Table 11. Jitter Attenuator Position Selection															
		<table border="1"> <thead> <tr> <th>JASEL 1</th> <th>JASEL 0</th> <th>POSITION</th> </tr> </thead> <tbody> <tr> <td>0</td> <td>0</td> <td>Disabled</td> </tr> <tr> <td>0</td> <td>1</td> <td>Transmit Path</td> </tr> <tr> <td>1</td> <td>0</td> <td>Disabled</td> </tr> <tr> <td>1</td> <td>1</td> <td>Receive Path</td> </tr> </tbody> </table>	JASEL 1	JASEL 0	POSITION	0	0	Disabled	0	1	Transmit Path	1	0	Disabled	1	1	Receive Path
JASEL 1	JASEL 0	POSITION															
0	0	Disabled															
0	1	Transmit Path															
1	0	Disabled															
1	1	Receive Path															

14.17 Line Length Channel ID Register (10h)

BIT	NAME	Description
[7:3]	RSVD 7-3	RESERVED (These bits must be set to 0.)
[2:0]	LLID 2-0	The value written to these bits specify the LIU channel for which the Pulse Shape Configuration Data (register 11h) applies. For example, writing a value of a binary 000 to the 3-LSBs will select channel 0. The pulse shape configuration data for the channel specified in this register are written or read through the Line Length Data Register (11h). Register bits default to 00h after power-up or reset.

14.18 Line Length Data Register (11h)

BIT	NAME	Description												
		The value written to the 4-LSBs of this register specifies whether the device is operating in either E1 75 Ω or E1 120 Ω mode and the associated pulse shape as shown below is being transmitted. Register bits default to 00h after power-up or reset.												
[7:5]	RSVD	RESERVED (These bits must be set to 0.)												
[4]	INT_EXTB	This bit specifies the use of internal (Int_ExtB = 1) or external (Int_ExtB = 0) receiver line matching. The line impedance for both the receiver and transmitter are chosen through the LEN [3:0] bits in this register.												
[3:0]	LEN[3:0]	These bits set the line impedance for both the receiver and the transmitter path and the desired pulse shape for a specific channel. The channel is selected with the Line Length Channel ID register (0x10). The following table shows the available transmitter pulse shapes. <div style="text-align: center;"> <p>Table 12. Transmitter Pulse Shape Selection</p> <table border="1"> <thead> <tr> <th>LEN [3:0]</th> <th>Operation Mode</th> <th>Line Length Selection</th> <th>Phase Samples per UI</th> </tr> </thead> <tbody> <tr> <td>0000</td> <td>E1</td> <td>120 Ω 3.0 V</td> <td>12</td> </tr> <tr> <td>1000</td> <td>E1</td> <td>75 Ω 2.37 V</td> <td>12</td> </tr> </tbody> </table> </div>	LEN [3:0]	Operation Mode	Line Length Selection	Phase Samples per UI	0000	E1	120 Ω 3.0 V	12	1000	E1	75 Ω 2.37 V	12
LEN [3:0]	Operation Mode	Line Length Selection	Phase Samples per UI											
0000	E1	120 Ω 3.0 V	12											
1000	E1	75 Ω 2.37 V	12											

14.19 Output Disable Register (12h)

BIT	NAME	Description
[7:0]	OENB 7-0	Setting bit n of this register to "1" High-Z the TX output driver on channel n of the device. Register bits default to 00h after power-up or reset.

14.20 AIS Status Register (13h)

BIT	NAME	Description
[7:0]	AISS 7-0	A "1" in bit position n indicates that the receiver has detected an AIS condition on channel n, which generates an interrupt on the INT pin. Register bits default to 00h after power-up or reset.

14.21 AIS Interrupt Enable Register (14h)

BIT	NAME	Description
[7:0]	AISE 7-0	This register enables changes in the AIS Status register to be reflected in the AIS Interrupt Status register, thus causing an interrupt on the INT pin. Register bits default to 00h after power-up or reset.

14.22 AIS Interrupt Status Register (15h)

BIT	NAME	Description
[7:0]	AISI 7-0	Bit n is set to "1" to indicate a change of status of bit n in the AIS Status Register. The bits in this register indicate which channel changed in status since the last cleared AIS interrupt. Register bits default to 00h after power-up or reset.

14.23 AWG Broadcast Register (16h)

BIT	NAME	Description
[7:0]	AWGB 7-0	Setting bit n to "1" causes the phase data in the AWG Phase Data Register to be written to the corresponding channel or channels simultaneously. (Refer to Arbitrary Waveform Generator (See Section 15 on page 42). Register bits default to 00h after power-up or reset.

14.24 AWG Phase Address Register (17h)

BIT	NAME	Description
[7:5]	AWGA	These bits specify the target channel 0-7. (Refer to Arbitrary Waveform Generator (See Section 15 on page 42). Register bits default to 00h after power-up or reset.
[4:0]	PA[4:0]	These bits specify 1 of 24 phase sample address locations of the AWG, that the phase data in the AWG Phase Data Register is written to or read from. Register bits default to 00h after power-up or reset.

14.25 AWG Phase Data Register (18h)

BIT	NAME	Description
[7]	RSVD	RESERVED (This bit must be set to 0.)
[6:0]	AWGD [6:0]	These bits are used for the pulse shape data that will be written to or read from the AWG phase location specified by the AWG Phase Address Register. The value written to or read from this register will be written to or read from the AWG phase sample location specified by the AWG Phase Address register. A software reset through the Software Reset Register does not effect the contents of this register. The data in each phase is a 7-bit 2's complement number (the maximum positive value is 3Fh and the maximum negative value is 40h). (Refer to Arbitrary Waveform Generator (See Section 15 on page 42). Register bits default to 00h after power-up.

14.26 AWG Enable Register (19h)

BIT	NAME	Description
[7:0]	AWGN 7-0	The AWG enable register is used for selecting the source of the customized transmission pulse-shape. Setting bit n to “1” in this register selects the AWG as the source of the output pulse shape for channel n. When bit n is set to “0” the pre-programmed pulse shape in the ROM is selected for transmission on channel n. (Refer to Arbitrary Waveform Generator (See Section 15 on page 42). Register bits default to 00h after power-up or reset.

14.27 Reserved Register (1Ah)

BIT	NAME	Description
[7:0]	RSVD 7-0	RESERVED

14.28 Reserved Register (1Bh)

BIT	NAME	Description
[7:0]	RSVD 7-0	RESERVED

14.29 Reserved Register (1Ch)

BIT	NAME	Description
[7:0]	RSVD 7-0	RESERVED

14.30 Reserved Register (1Dh)

BIT	NAME	Description
[7:0]	RSVD 7-0	RESERVED

14.31 Bits Clock Enable Register (1Eh)

BIT	NAME	Description
[7:0]	BITS 7-0	Writing a “1” to bit n in this register changes channel n to a stand-alone timing recovery unit used for G.703 clock recovery. (Refer to BUILDING INTEGRATED TIMING SYSTEMS (BITS) CLOCK MODE (See Section 8 on page 23) for a better description of the G.703 clock recovery function). Register bits default to 00h after power-up or reset.

14.32 Reserved Register (1Fh)

BIT	NAME	Description
[7:0]	RSVD 7-0	RESERVED

14.33 Status Registers

The following Status registers are read-only: **LOS Status Register (04h)** (See Section 14.5 on page 35), **DFM Status Register (05h)** (See Sec-

tion 14.6 on page 35) and **AIS Status Register (13h)** (See Section 14.20 on page 38). The CS61880 generates an interrupt on the $\overline{\text{INT}}$ pin any time an unmasked status register bit changes.

14.33.1 Interrupt Enable Registers

The Interrupt Enable registers: **LOS Interrupt Enable Register (06h)** (See Section 14.7 on page 36), **DFM Interrupt Enable Register (07h)** (See Section 14.8 on page 36), **AIS Interrupt Enable Register (14h)** (See Section 14.21 on page 39), enable changes in status register state to cause an interrupt on the $\overline{\text{INT}}$ pin. Interrupts are maskable on a per channel basis. When an Interrupt Enable register bit is 0, the corresponding Status register bit is disabled from causing an interrupt on the $\overline{\text{INT}}$ pin.

NOTE: Disabling an interrupt has no effect on the status reflected in the associated status register.

14.33.2 Interrupt Status Registers

The following interrupt status registers: **LOS Interrupt Status Register (08h)** (See Section 14.9 on page 36), **DFM Interrupt Status Register (09h)** (See Section 14.10 on page 36), **AIS Interrupt Status Register (15h)** (See Section 14.22 on page 39), indicate a change in status of the corresponding status registers in host mode. Reading these registers clears the interrupt, which deactivates the $\overline{\text{INT}}$ pin.

15. ARBITRARY WAVEFORM GENERATOR

Using the Arbitrary Waveform Generator (AWG) allows the user to customize the transmit pulse shapes to compensate for nonstandard cables, transformers, protection circuitry, or to reduce power consumption by reducing the output pulse amplitude. A channel is configured for a custom pulse shape by enabling the AWG for that channel and then storing data representing the pulse shape into the 24 phase sample locations. Each channel has a separate AWG, so all eight channels can have a different customized pulse shape. The microprocessor interface, is used to read from or write to the AWG, while the device is in host mode.

In the AWG RAM, the pulse shape is divided into two unit intervals (UI). There are 12 phase sample addresses in each UI. The first UI is for the main part of the pulse and the second UI is for the “tail” of the pulse (Refer to Figure 13). A complete pulse-shape is represented by 24 phase samples. Data written in the first UI represents a valid pulse shape, while data in the second UI must be set to zero at all times. Writing values other than zero to the second UI will cause the pulse shape to be invalid.

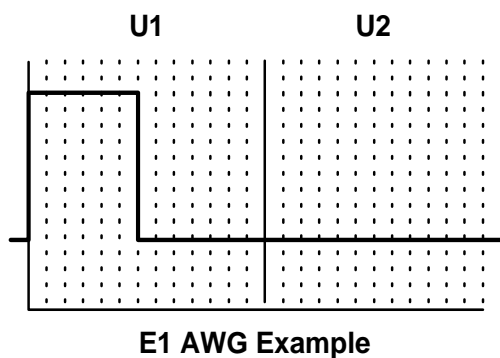

Figure 13. Arbitrary Waveform UI

The data in each phase sample is a 7-bit two’s complement number with a maximum positive value of 0x3f, and a maximum negative value of 0x40. The terms “positive” and “negative” are defined for a positive going pulse only. The pulse generation circuitry automatically inverts the pulse for negative going pulses. The data stored in the lowest phase address corresponds to the first phase sample that will be transmitted in time. The typical voltage step for each mode of operation is as follows: for E1 75 Ω mode the typical voltage step is 42 mV/LSB and for E1 120 Ω mode the typical voltage step is 54 mV/LSB all voltage steps are measured across the transformer secondary.

The following procedure describes how to enable and write data into the AWG RAM to produce customized pulse shapes to be transmitted for a specific channel or channels. First, enable the AWG function for a specific channel or channels by writing a “1” to the corresponding bits in the **AWG Enable Register (19h)** (See Section 14.26 on page 40). When the corresponding bit or bits in the AWG Enable Register are set to “0” pre-programmed pulse shapes are selected for transmission. Then the desired channel and phase sample address must be written to the **AWG Phase Address Register (17h)** (See Section 14.24 on page 39). Once the channel and phase sample address have been written, the actual phase sample data may be entered into the **AWG Phase Data Register (18h)** (See Section 14.25 on page 39) at the selected phase sample address selected by the lower five bits of the **AWG Phase Address Register (17h)** (See Section 14.24 on page 39)).

To change the phase sample address of the selected channel the user may use either of the following steps. The user can re-write the phase sample address to the AWG Phase Address Register or set the Auto-Increment bit (Bit 7) in the **Global Control Register (0Fh)** (See Section 14.16 on page 37) to “1” before writing to the AWG Phase Data Register. When this bit is set to “1” only the first phase

sample address (00000 binary) needs to be written to the **AWG Phase Address Register (17h)** (See Section 14.24 on page 39), and each subsequent access (read or write) to the **AWG Phase Data Register (18h)** (See Section 14.25 on page 39) will automatically increment the phase sample address. The channel address, however, remains unaffected by the Auto-Increment mode. The **AWG Phase Address Register (17h)** (See Section 14.24 on page 39) needs to be re-written in order to re-start the phase sample address sequence from the new phase sample address.

The AWG Broadcast function allows the same data to be written to multiple channels simultaneously. This is done with the use of the **AWG Broadcast Register (16h)** (See Section 14.23 on page 39), each bit in the AWG Broadcast Register corresponds to a different channel (e.g. bit 0 is channel 0, and bit 3 is channel 3 and etc.). To use the AWG Broadcast function MCLK must be present. When MCLK is inactive the AWG Broadcast function is disabled.

To write the same pulse shaping data to multiple channels, simply set the corresponding bit to “1” in the **AWG Broadcast Register (16h)** (See Section 14.23 on page 39) before accessing the AWG phase data register. This function only requires that one of the eight channel addresses be written to the **AWG Phase Address Register (17h)** (See Section 14.24 on page 39). During an AWG read sequence, the bits in the AWG Broadcast Register are ignored. During an AWG write sequence, the selected channel or channels are specified by both the channel address specified by the upper bits of the **AWG Phase Address Register (17h)** (See Section 14.24 on page 39) and the selected channel or chan-

nels in the **AWG Broadcast Register (16h)** (See Section 14.23 on page 39).

During a multiple channel write the first channel that is written to, is the channel that was addressed by the AWG Phase Address Register. This channel’s bit in the AWG Broadcast Register can be set to either “1” or “0”.

For a more descriptive explanation of how to use the AWG function refer to the Application Note *AN204, How To Use The CS61880/CS61884 Arbitrary Waveform Generator*.

16. JTAG SUPPORT

The CS61880 supports the IEEE Boundary Scan Specification as described in the IEEE 1149.1 standards. A Test Access Port (TAP) is provided that consists of the TAP controller, the instruction register (IR), by-pass register (BPR), device ID register (IDR), the boundary scan register (BSR), and the 5 standard pins ($\overline{\text{TRST}}$, TCK, TMS, TDI, and TDO). A block diagram of the test access port is shown in Figure 14 on page 44. The test clock input (TCK) is used to sample input data on TDI, and shift output data through TDO. The TMS input is used to step the TAP controller through its various states.

The instruction register is used to select test execution or register access. The by-pass register provides a direct connection between the TDI input and the TDO output. The device identification register contains a 32-bit device identifier.

The Boundary Scan Register is used to support testing of IC inter-connectivity. Using the Boundary Scan Register, the digital input pins can be sampled and shifted out on TDO. In addition, this register can also be used to drive digital output pins to a user defined state.

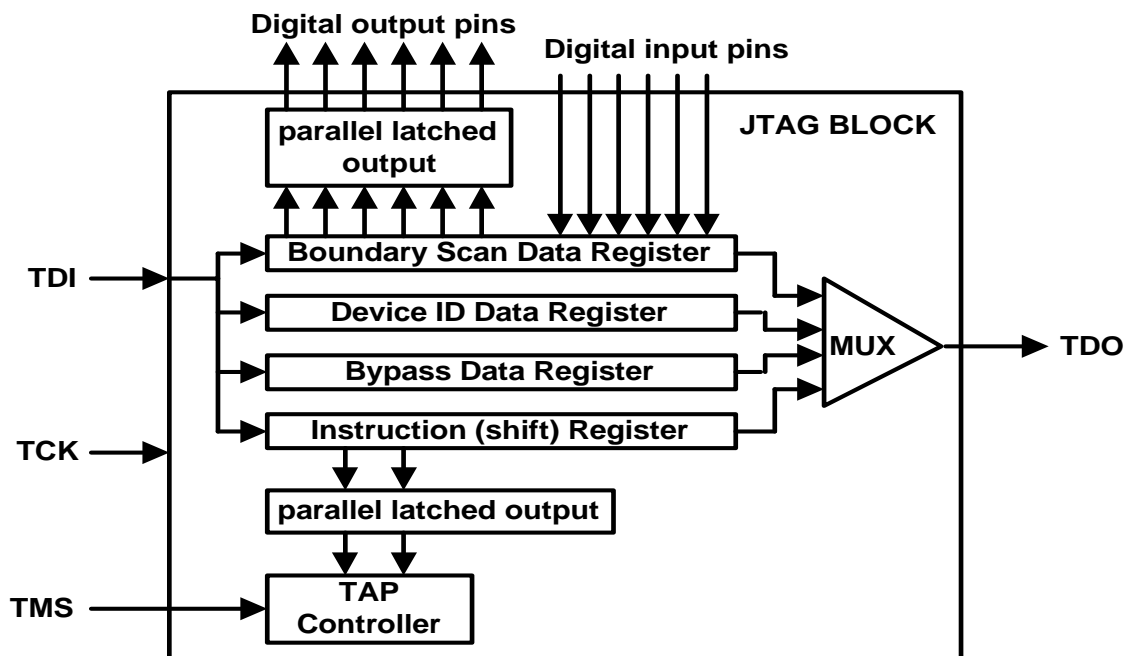

Figure 14. Test Access Port Architecture

16.1 TAP Controller

The TAP Controller is a 16 state synchronous state machine clocked by the rising edge of TCK. The TMS input governs state transitions as shown in Figure 15. The value shown next to each state transition in the diagram is the value that must be on TMS when it is sampled by the rising edge of TCK.

16.1.1 JTAG Reset

TRST resets all JTAG circuitry.

16.1.2 Test-Logic-Reset

The test-logic-reset state is used to disable the test logic when the part is in normal mode of operation. This state is entered by asynchronously asserting $\overline{\text{TRST}}$ or forcing TMS High for 5 TCK periods.

16.1.3 Run-Test-Idle

The run-test-idle state is used to run tests.

16.1.4 Select-DR-Scan

This is a temporary controller state.

16.1.5 Capture-DR

In this state, the Boundary Scan Register captures input pin data if the current instruction is EXTEST or SAMPLE/PRELOAD.

16.1.6 Shift-DR

In this controller state, the active test data register connected between TDI and TDO, as determined by the current instruction, shifts data out on TDO on each rising edge of TCK.

16.1.7 Exit1-DR

This is a temporary state. The test data register selected by the current instruction retains its previous value.

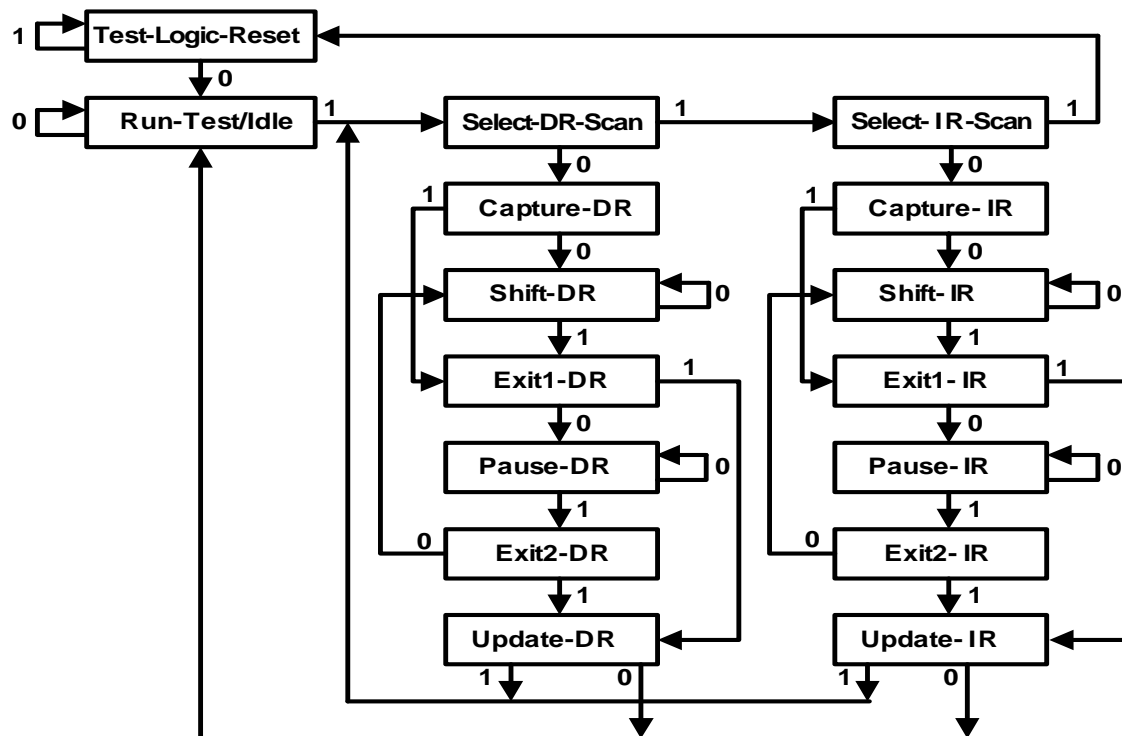

Figure 15. TAP Controller State Diagram

16.1.8 *Pause-DR*

The pause state allows the test controller to temporarily halt the shifting of data through the current test data register.

16.1.9 *Exit2-DR*

This is a temporary state. The test data register selected by the current instruction retains its previous value.

16.1.10 *Update-DR*

The Boundary Scan Register is provided with a latched parallel output to prevent changes while data is shifted in response to the EXTEST and SAMPLE/PRELOAD instructions. When the TAP controller is in this state and the Boundary Scan Register is selected, data is latched into the parallel output of this register from the shift-register path

on the falling edge of TCK. The data held at the latched parallel output changes only in this state.

16.1.11 *Select-IR-Scan*

This is a temporary controller state. The test data register selected by the current instruction retains its previous state.

16.1.12 *Capture-IR*

In this controller state, the instruction register is loaded with a fixed value of “01” on the rising edge of TCK. This supports fault-isolation of the board-level serial test data path.

16.1.13 *Shift-IR*

In this state, the shift register contained in the instruction register is connected between TDI and TDO and shifts data one stage towards its serial output on each rising edge of TCK.

16.1.14 Exit1-IR

This is a temporary state. The test data register selected by the current instruction retains its previous value.

16.1.15 Pause-IR

The pause state allows the test controller to temporarily halt the shifting of data through the instruction register.

16.1.16 Exit2-IR

This is a temporary state. The test data register selected by the current instruction retains its previous value.

16.1.17 Update-IR

The instruction shifted into the instruction register is latched into the parallel output from the shift-register path on the falling edge of TCK. When the new instruction has been latched, it becomes the current instruction. The test data registers selected by the current instruction retain their previous value.

16.2 Instruction Register (IR)

The 3-bit Instruction register selects the test to be performed and/or the data register to be accessed. The valid instructions are shifted in LSB first and are listed in Table 13:

Table 13. JTAG Instructions

IR CODE	INSTRUCTION
000	EXTEST
100	SAMPLE/PRELOAD
110	IDCODE
111	BYPASS

16.2.1 EXTEST

The EXTEST instruction allows testing of off-chip circuitry and board-level interconnect. EXTEST connects the BSR to the TDI and TDO pins.

16.2.2 SAMPLE/PRELOAD

The SAMPLE/PRELOAD instruction samples all device inputs and outputs. This instruction places the BSR between the TDI and TDO pins. The BSR is loaded with samples of the I/O pins by the Capture-DR state.

16.2.3 IDCODE

The IDCODE instruction connects the device identification register to the TDO pin. The device identification code can then be shifted out TDO using the Shift-DR state.

16.2.4 BYPASS

The BYPASS instruction connects a one TCK delay register between TDI and TDO. The instruction is used to bypass the device.

16.3 Device ID Register (IDR)

Revision section: 0h = Rev A, 1h = Rev B and so on. The device Identification Code [27 - 12] is derived from the last three digits of the part number (880). The LSB is a constant 1, as defined by IEEE 1149.1.

CS61880 IDCODE REGISTER(IDR)																															
REVISION				DEVICE IDCODE REGISTER												MANUFACTURER CODE															
31	30	29	28	27	26	25	24	23	22	21	20	19	18	17	16	15	14	13	12	11	10	9	8	7	6	5	4	3	2	1	0
0h				0h				8h				8h				0h				0h				Ch				9h			
0	0	0	0	0	0	0	0	0	1	0	0	0	1	0	0	0	0	0	0	0	0	0	0	1	1	0	0	1	0	0	1

17. BOUNDARY SCAN REGISTER (BSR)

The BSR is a shift register that provides access to the digital I/O pins. The BSR is used to read and write the device pins to verify interchip connectivity. Each pin has a corresponding scan cell in the register. The pin to scan cell mapping is given in the Boundary Scan Register description shown in Table 14.

NOTE: Data is shifted LSB first into the BSR register.

Table 14. Boundary Scan Register

BSR Bit	Pin Name	Cell Type	Bit Symbol
0	LOS7	O	LOS7
1	RNEG7	O	RNEG7
2	RPOS7	O	RPOS7
3	RCLK7	O	RCLK7
4	-	Note 2	HIZ7_B
5	TNEG7	I	TNEG7
6	TPOS7	I	TPOS7
7	TCLK7	I	TCLK7
8	LOS6	O	LOS6_B
9	RNEG6	O	RNEG6
10	RPOS6	O	RPOS6
11	RCLK6	O	RCLK6
12	-	Note 2	HIZ6_B
13	TNEG6	I	TNEG6
14	TPOS6	I	TPOS6
15	TCLK6	I	TCLK6
16	MCLK	I	MCLK
17	MODE	I	MODE_TRI
18	MODE	I	MODE_IN
19	ADDR4	I	ADDR4
20	ADDR3	I	ADDR3
21	ADDR2	I	ADDR2
22	ADDR1	I	ADDR1
23	ADDR0	I	ADDR0
24	LOOP0/D0	I	LPT0
25	LOOP0/D0	I	LPI0
26	LOOP0/D0	O	LPO0
27	LOOP1/D1	I	LPT1

Table 14. Boundary Scan Register (Continued)

BSR Bit	Pin Name	Cell Type	Bit Symbol
28	LOOP1/D1	I	LPI1
29	LOOP1/D1	O	LPO1
30	LOOP2/D2	I	LPT2
31	LOOP2/D2	I	LPI2
32	LOOP2/D2	O	LPO2
33	LOOP3/D3	I	LPT3
34	LOOP3/D3	I	LPI3
35	LOOP3/D3	O	LPO3
36	LOOP4/D4	I	LPT4
37	LOOP4/D4	I	LPI4
38	LOOP4/D4	O	LPO4
39	LOOP5/D5	I	LPT5
40	LOOP5/D5	I	LPI5
41	LOOP5/D5	O	LPO5
42	LOOP6/D6	I	LPT6
43	LOOP6/D6	I	LPI6
44	LOOP6/D6	O	LPO6
45	LOOP7/D7	I	LPT7
46	LOOP7/D7	I	LPI7
47	LOOP7/D7	O	LPO7
48	-	Note 1	LPOEN
49	TCLK1	I	TCLK1
50	TPOS1	I	TPOS1
51	TNEG1	I	TNEG1
52	RCLK1	O	RCLK1
53	RPOS1	O	RPOS1
54	RNEG1	O	RNEG1
55	-	Note 2	HIZ1_B
56	LOS1	O	LOS1
57	TCLK0	I	TCLK0
58	TPOS0	I	TPOS0
59	TNEG0	I	TNEG0
60	RCLK0	O	RCLK0
61	RPOS0	O	RPOS0
62	RNEG0	O	RNEG0
63	-	Note 2	HIZ0_B
64	LOS0	O	LOS0
65	MUX	I	MUX
66	LOS3	O	LOS3
67	RNEG3	O	RNEG3
68	RPOS3	O	RPOS3
69	RCLK3	O	RCLK3
70	-	Note 2	HIZ3_B
71	TNEG3	I	TNEG3
72	TPOS3	I	TPOS3

Table 14. Boundary Scan Register (Continued)

BSR Bit	Pin Name	Cell Type	Bit Symbol
73	TCLK3	I	TCLK3
74	LOS2	O	LOS2
75	RNEG2	O	RNEG2
76	RPOS2	O	RPOS2
77	RCLK2	O	RCLK2
78	-	Note 2	HIZ2_B
79	TNEG2	I	TNEG2
80	TPOS2	I	TPOS2
81	TCLK2	I	TCLK2
82	INT_B	O	INT_B
83	RDY	O	RDYOUT
84	-	Note 3	RDYOEN
85	WR_B	I	WR_B
86	RD_B	I	RD_B
87	ALE	I	ALE
88	CS_B	I	CS_B
89	CS_B	I	CS_B_TRI
90	INTL	I	INTL
91	CBLSEL	I	CBLSEL_TRI
92	CBLSEL	I	CBLSEL_IN
93	TCLK5	I	TCLK5
94	TPOS5	I	TPOS5
95	TNEG5	I	TNEG5
96	RCLK5	O	RCLK5
97	RPOS5	O	RPOS5
98	RNEG5	O	RNEG5
99	-	Note 2	HIZ5_B
100	LOS5	O	LOS5
101	TCLK4	I	TCLK4
102	TPOS4	I	TPOS4
103	TNEG4	I	TNEG4
104	RCLK4	O	RCLK4
105	RPOS4	O	RPOS4
106	RNEG4	O	RNEG4
107	-	Note 2	HIZ4_B
108	LOS4	O	LOS4
109	TXOE	I	TXOE
110	CLKE	I	CLKE

Notes:

- 1) LPOEN controls the LOOP[7:0] pins. Setting LPOEN to "1" configures LOOP[7:0] as outputs. The output value driven on the pins are determined by the values written to LPO[7:0]. Setting LPOEN to "0" High-Z all the pins. In this mode, the input values driven to these LOOP[7:0] can be read via LPI[7:0].
- 2) HIZ_B controls the RPOSt, RNEGx, and RCLKx pins. When HIZ_B is High, the outputs are enabled; when HIZ_B is Low, the outputs are placed in a high impedance state (High-Z).
- 3) RDYOEN controls the ACK_B pin. Setting RDYOEN to "1" enables output on ACK_B. Setting ACKEN to "0" High -Z the ACK_B pin.

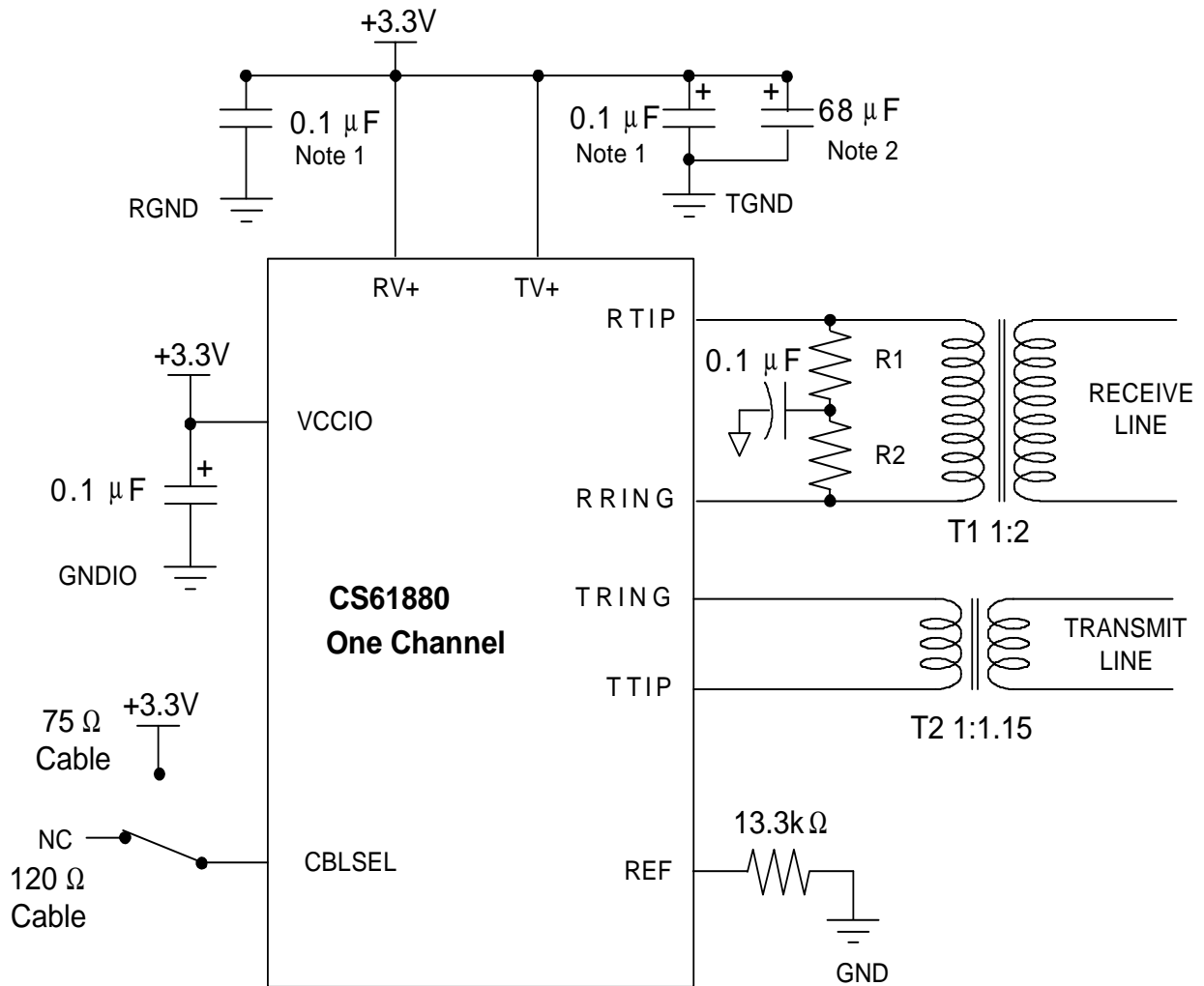
18. APPLICATIONS

Component	E1 75Ω Coaxial Cable	E1 120Ω Twisted Pair Cable
R1 (Ω)	15	15
R2 (Ω)	15	15

Notes: 1) Required Capacitor between each TV+, RV+, VCCIO and TGND, RGND, GNDIO respectively.

2) Common decoupling capacitor for all TVCC and TGND pins.

Figure 16. Internal RX/TX Impedance Matching

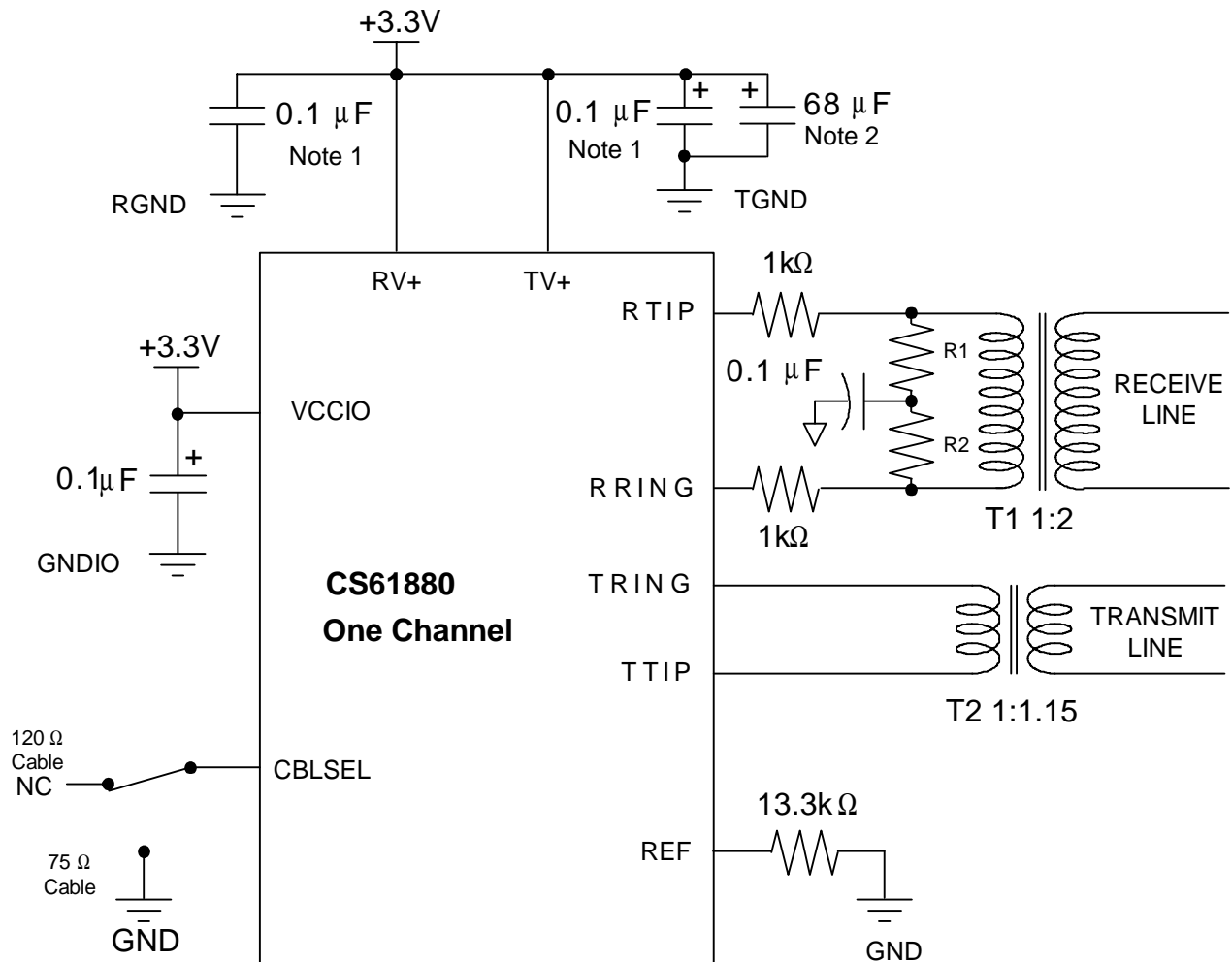

Component	E1 75 Ω Coaxial Cable	E1 120 Ω Twisted Pair Cable
R1 (Ω)	9.31	15
R2 (Ω)	9.31	15

Notes: 1) Required Capacitor between each TV+, RV+, VCCIO and TGND, RGND, GNDIO respectively.

2) Common decoupling capacitor for all TVCC and TGND pins.

Figure 17. Internal TX, External RX Impedance Matching

18.1 Transformer Specifications

Recommended transformer specifications are shown in Table 15. Any transformer used with the CS61880 should meet or exceed these specifications.

Table 15. Transformer Specifications

Descriptions	Specifications
Turns Ratio Receive	1:2
Turns Ratio Transmit	1:1.15
Primary Inductance	1.5 mH min @ 1024 kHz
Primary Leakage Inductance	0.3 μ H max @ 1024 kHz
Secondary leakage Inductance	0.4 μ H max @ 1024 kHz
Inter winding Capacitance	18 pF max, primary to secondary
ET-Constant	16 V - μ s min

18.2 Crystal Oscillator Specifications

When a reference clock signal is not available, a CMOS crystal oscillator may be used as the reference clock signal. The oscillator must have a minimum symmetry of 40-60% and minimum stability of ± 100 ppm.

18.3 Line Protection

Secondary protection components can be added to the line interface circuitry to provide lightning surge and AC power-cross immunity. For additional information on the different electrical safety standards and specific applications circuit recommendations, refer to Application Note AN034, *Secondary Line Protection for T1 and E1 Cards*.

19. CHARACTERISTICS AND SPECIFICATIONS

19.1 Absolute Maximum Ratings

CAUTION: Operations at or beyond these limits may result in permanent damage to the device. Normal operation is not guaranteed at these extremes.

Parameter	Symbol	Min.	Max	Units	
DC Supply (referenced to RGND = TGND = 0V)	RV+ TV+	- -	4.0 4.0	V V	
DC Supply	VCCIO	-0.5	4.6	V	
Input Voltage, Any Digital Pin except CBLSEL, MODE and LOOP(n) pins (referenced to GNDIO = 0V)	V _{IH}	GNDIO -0.5	5.3	V	
Input Voltage CBLSEL, MODE & LOOP(n) Pins (referenced to GNDIO = 0V)	V _{IH}	GNDIO -0.5	VCCIO +0.5	V	
Input voltage, RTIP and RRING Pins		TGND -0.5	TV+ +0.5	V	
ESD voltage, Any pin	Note 1	2k	-	V	
Input current, Any Pin	Note 2	I _{IH}	-10	+10	mA
Maximum Power Dissipation, In package	P _p	-	1.73	W	
Ambient Operating Temperature	T _A	-40	85	C	
Storage Temperature	T _{stg}	-65	150	C	

19.2 Recommended Operating Conditions

Parameter	Symbol	Min.	Typ	Max	Units	
DC Supply	RV+, TV+	3.135	3.3	3.465	V	
DC Supply	VCCIO	3.135	3.3	3.465	V	
Ambient operating Temperature	T _A	-40	25	85	C	
Power Consumption, E1 Mode, 75 Ω line load	Notes 3, 4, 5	-	-	660	1040	mW
Power Consumption, E1 Mode, 120 Ω line load	Notes 3, 4, 5	-	-	640	950	mW

- Notes:
- Human Body Model
 - Transient current of up to 100 mA will not cause SCR latch-up. Also TTIP, TRING, TV+ and TGND can withstand a continuous current of 100 mA.
 - Power consumption while driving line load over the full operating temperature and power supply voltage range. Includes all IC channels and loads. Digital inputs are within 10% of the supply rails and digital outputs are driving a 50 pF capacitive load.
 - Typical consumption corresponds to 50% ones density for at 3.3 V.
 - Maximum consumption corresponds to 100% ones density at 3.465 V.
 - This specification guarantees TTL compatibility (V_{OH} = 2.4 V @ I_{OUT} = -400 μA).
 - Output drivers are TTL compatible.
 - Pulse amplitude measured at the output of the transformer across a 75 Ω load.
 - Pulse amplitude measured at the output of the transformer across a 120 Ω load.

19.3 Digital Characteristics

(TA = -40° C to 85° C; TV+, RV+ = 3.3 V ±5%; GND = 0 V)

Parameter	Symbol	Min.	Typ	Max	Units
High-Level Input Voltage Note 6	V _{IH}	2.0	-	-	V
Low-Level Input Voltage Note 6	V _{IL}	-	-	0.8	V
LOOP[7:0] Low-Level Input Voltage	V _{IHL}	-	-	1/3 VCCIO-0.2	V
LOOP[7:0] Mid-Level Input Voltage	V _{IHM}	1/3 VCCIO +0.2	1/2 VCCIO	2/3 VCCIO-0.2	V
LOOP[7:0] High-Level Input Voltage	V _{IHH}	2/3 VCCIO +0.2	-	-	V
High-Level Output Voltage I _{OUT} = -400 μA Notes 6, 7	V _{OH}	2.4	-	-	V
Low-Level Output Voltage I _{OUT} = 1.6 mA Notes 6, 7	V _{OL}	-	-	0.4	V
Input Leakage Current		-10	-	+10	μA
Input leakage for LOOP pins		-150		+150	μA

19.4 Transmitter Analog Characteristics

(TA = -40° C to 85° C; TV+, RV+ = 3.3 V ±5%; GND = 0 V)

Parameter	Min.	Typ	Max	Units	
Output Pulse Amplitudes Notes 8, 9, 11	E1 75 Ω	2.14	2.37	2.6	V
	E1 120 Ω	2.7	3.0	3.3	V
Ratio of Positive to Negative pulses Notes 8, 9, 11	Amplitude at center of pulse interval	0.95	-	1.05	
	Width at 50% of nominal amplitude	0.95	-	1.05	
Pulse Amplitude of a space	E1 120 Ω	-0.3	-	0.3	V
	E1 75 Ω	-0.237	-	0.237	V
Transmit Return Loss Notes 10, 11, 12	51 kHz to 102 kHz	-14	-20	-	dB
	102 kHz to 2048 kHz	-14	-19	-	
	2048 kHz to 3072 kHz	-14	-18	-	
Jitter Added by the Transmitter Notes 10, 13	10 Hz - 8 kHz	-	0.010	0.020	UI
	8 kHz - 40 kHz	-	0.009	0.025	
	10 Hz - 40 kHz	-	0.007	0.025	
	Broad Band	-	0.015	0.050	
Transmitter Short Circuit Current per channel	-	-	50	mA RMS	

19.5 Receiver Analog Characteristics

(TA = -40° C to 85° C; TV+, RV+ = 3.3 V ±5%; GND = 0 V)

Parameter		Min.	Typ	Max	Units
Allowable Cable Attenuation @ 1024 kHz		-	-	- 12	dB
RTIP/RRING Input Impedance (Internal Line matching mode) Note 10	E1 120 Ω Load	-	13k	-	Ω
	E1 75 Ω Load	-	50	-	
RTIP/RRING Input Impedance (External Line matching mode) Note 10	E1 120 Ω Load	-	13k	-	Ω
	E1 75 Ω Load	-	13k	-	
Receiver Dynamic Range		0.5	-	-	Vp
Signal to Noise margin (Per G.703, O151 @ 6 dB cable Atten).		-	-18	-	dB
Receiver Squelch Level			150		mV
LOS Threshold		-	200	-	mV
LOS Hysteresis			50		mV
Data Decision Threshold Note 10		41	50	59	% of peak
Input Jitter Tolerance Notes 10, 14, 16	1 Hz - 1.8 Hz	18	-	-	UI
	20 Hz - 2.4 kHz	1.5	-	-	
	18 kHz - 100 kHz	0.2	-	-	
Input Return Loss Notes 10, 11, 12	51 kHz - 102 kHz	-18	-28	-	dB
	102 kHz - 2048 kHz	-18	-30	-	
	2048 kHz - 3072 kHz	-18	-27	-	

- Notes: 10. Parameters guaranteed by design and characterization.
 11. Using components on the CDB61880 evaluation board in Internal Match Impedance Mode.
 12. Return loss = $20\log_{10} \text{ABS}((Z1 + Z0) / (Z1 - Z0))$ where Z1 - impedance of the transmitter or receiver, and Z0 = cable impedance.
 13. Assuming that jitter free clock is input to TCLK.
 14. Jitter tolerance for 6 dB input signal levels. Jitter tolerance increases at lower frequencies. HDB3 coders enabled.
 15. In Data Recovery Mode.
 16. Jitter Attenuator in the receive path.

19.6 Jitter Attenuator Characteristics

(TA = -40° C to 85° C; TV+, RV+ = 3.3 V ±5%; GND = 0 V)

Parameter		Min.	Typ	Max	Units
Jitter Attenuator Corner Frequency Note 10, 18 (Depends on JACF Bit in host mode)		-	1.25 2.50	-	Hz
E1 Jitter Attenuation Note 10, 17	3 Hz to 40 Hz 400 Hz to 100 kHz	+ 0.5 -19.5	- -	- -	dB
Attenuator Input Jitter Tolerance before FIFO over flow and under flow Note 10	32-bit FIFO	-	24	-	UI
	64-bit FIFO	-	56	-	UI
Delay through Jitter Attenuator Only Note 10	32-bit FIFO	-	16	-	UI
	64-bit FIFO	-	32	-	UI
Intrinsic Jitter in Remote Loopback	Notes 10, 16	-	-	0.11	UI

- Notes: 17. Attenuation measured with sinusoidal input filter equal to 3/4 of measured jitter tolerance. Circuit attenuates jitter at 20 dB/decade above the corner frequency. Output jitter can increase significantly when more than 28 UI's are input to the attenuator.
18. Measurement is not effected by the position of the Jitter Attenuator.

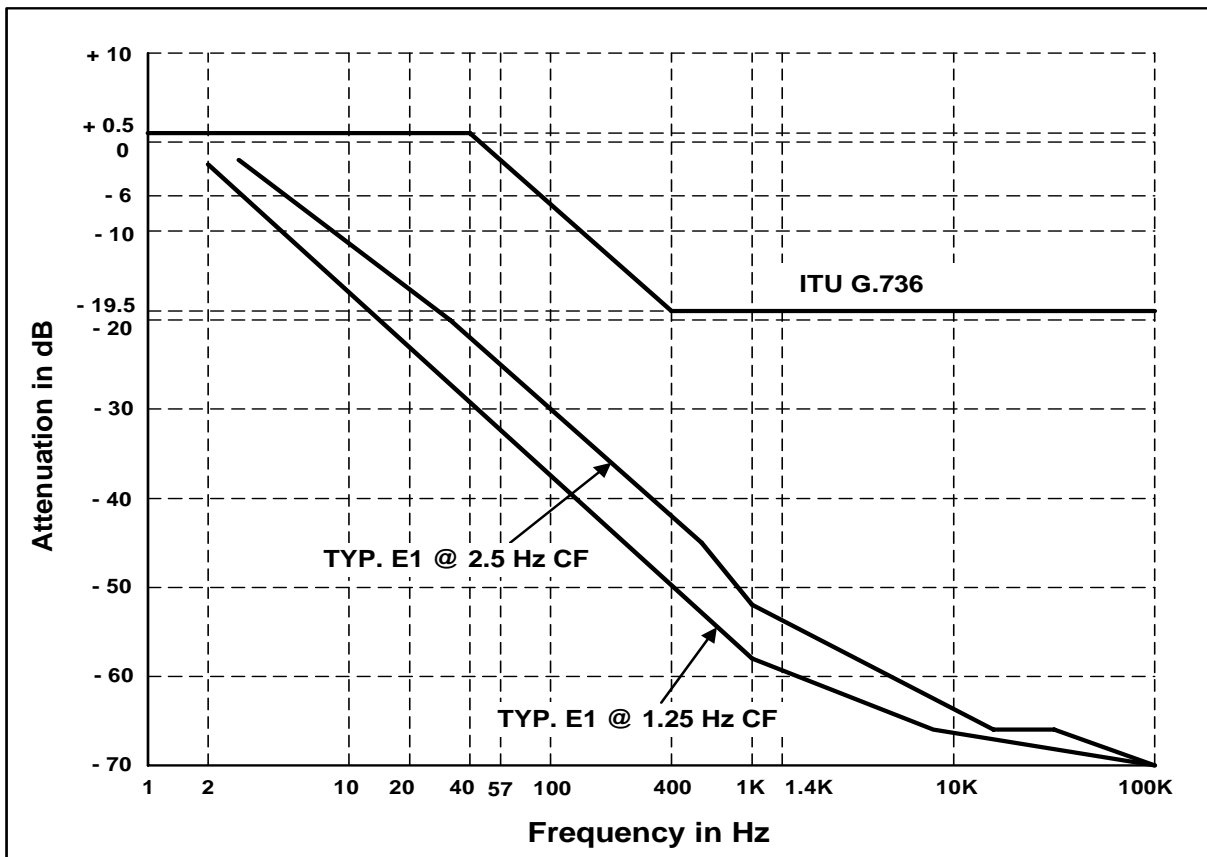

Figure 18. Jitter Transfer Characteristic vs. G.736 & TBR 12/13

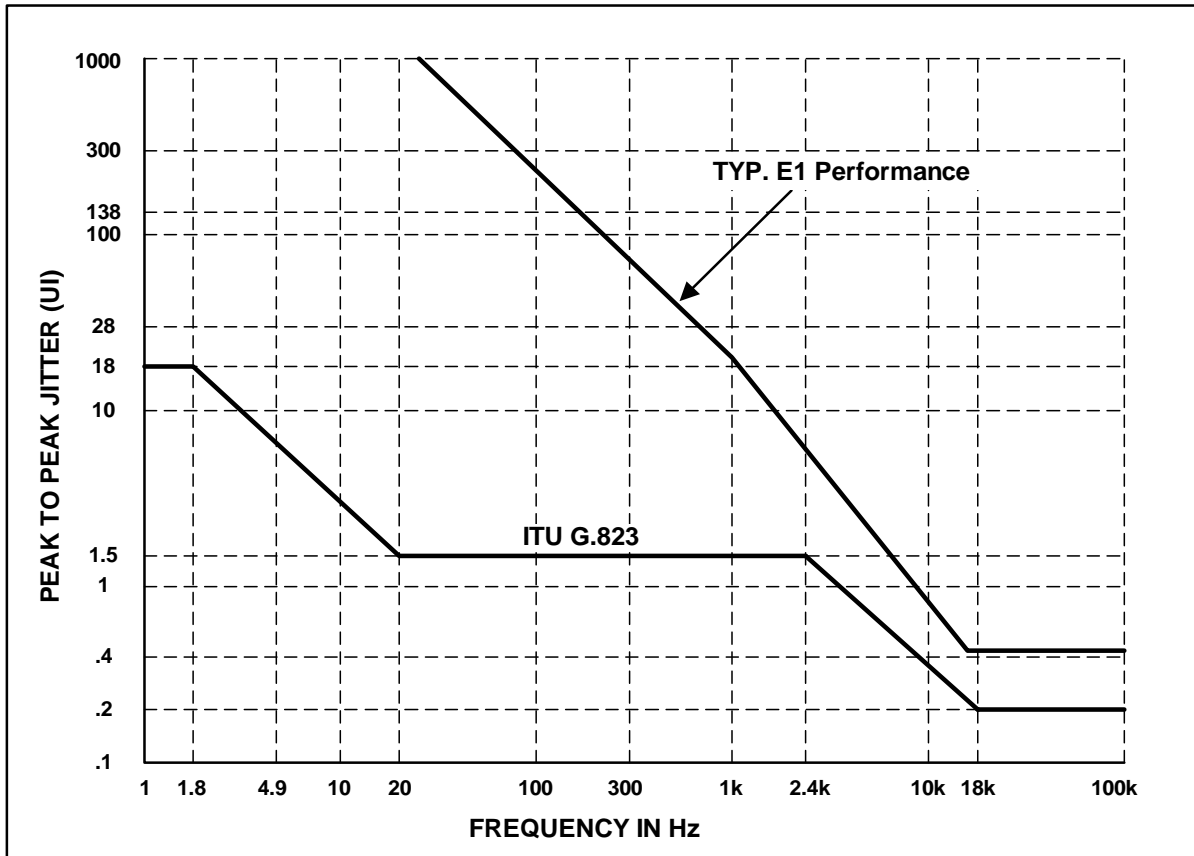

Figure 19. Jitter Tolerance Characteristic vs. G.823

19.7 Master Clock Switching Characteristics

Parameter	Symbol	Min.	Typ	Max	Units
MASTER CLOCK (MCLK)					
Master Clock Frequency	MCLK		2.048		MHz
Master Clock Tolerance	-	-100		+100	ppm
Master Clock Duty Cycle	-	40	50	60	%

19.8 Transmit Switching Characteristics

Parameter	Symbol	Min.	Typ	Max	Units
TCLK Frequency	$1/t_{pw2}$	-	2.048	-	MHz
TPOS/TNEG Pulse Width (RZ Mode)		236	244	252	ns
TCLK Tolerance (NRZ Mode)		-50	-	50	PPM
TCLK Duty Cycle	t_{pwh2}/t_{pw2}	-	-	90	%
TCLK Pulse Width		20	-	-	ns
TCLK Burst Rate	Note 10	-	-	20	MHz
TPOS/TNEG to TCLK Falling Setup Time (NRZ Mode)	t_{su2}	25	-	-	ns
TCLK Falling to TPOS/TNEG Hold time (NRZ Mode)	t_{h2}	25	-	-	ns
TXOE Asserted Low to TX Driver HIGH-Z		-	-	1	μ s
TCLK Held Low to Driver HIGH-Z	Note 20	8	12	20	μ s

19.9 Receive Switching Characteristics

Parameter	Symbol	Min.	Typ	Max	Units
RCLK Duty Cycle	Note 10	40	50	60	%
RCLK Pulse Width	Note 10	196	244	328	ns
RPOS/RNEG Pulse Width (RZ Mode)	Note 10	200	244	300	ns
RPOS/RNEG to RCLK rising setup time	Note 10	t_{su}	244		ns
RPOS/RNEG to RCLK hold time	Note 10	t_h	244		ns
RPOS/RNEG Output to RCLK Output (RZ Mode)	Note 10	-	-	10	ns
Rise/Fall Time, RPOS, RNEG, RCLK, LOS outputs	Note 19	t_r, t_f	-	85	ns

Notes: 19. Output load capacitance = 50 pF.

20. MCLK is not active.

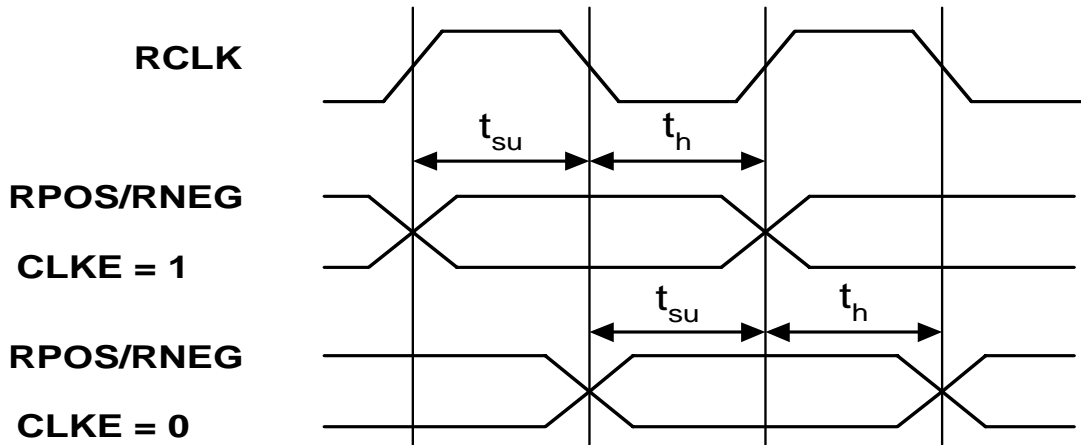

Figure 20. Recovered Clock and Data Switching Characteristics

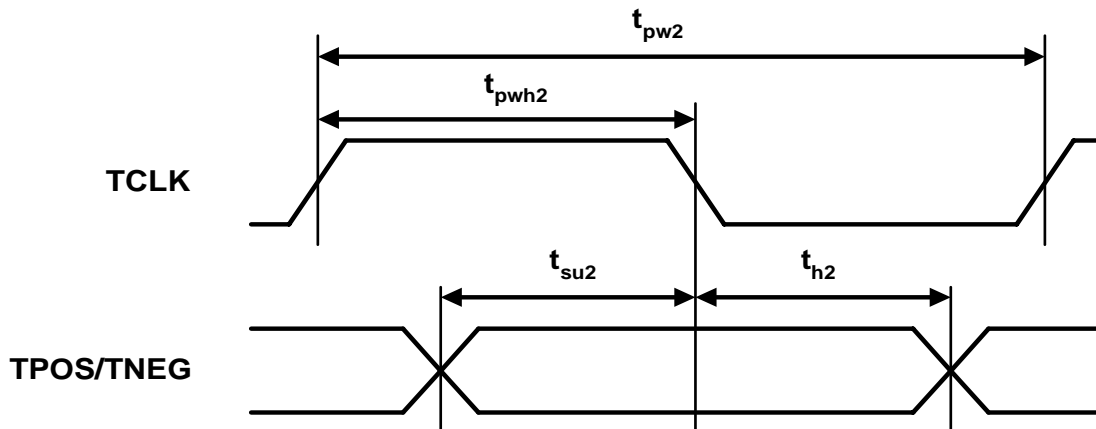

Figure 21. Transmit Clock and Data Switching Characteristics

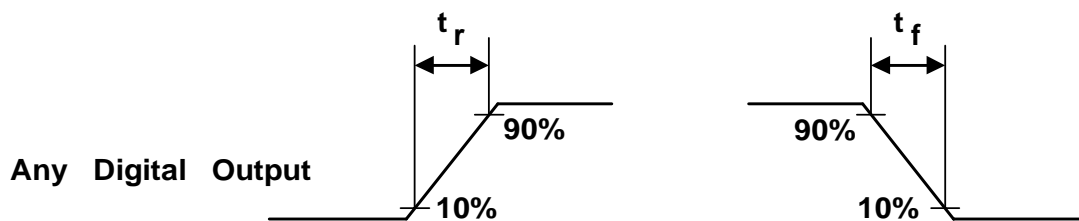

Figure 22. Signal Rise and Fall Characteristics

19.10 Switching Characteristics - Serial Port

Parameter	Symbol	Min.	Typ.	Max	Unit
SDI to SCLK Setup Time	t_{dc}	-	20	-	ns
SCLK to SDI Hold Time	t_{cdh}	-	20	-	ns
SCLK Low Time	t_{cl}	-	50	-	ns
SCLK High Time	t_{ch}	-	50	-	ns
SCLK Rise and Fall Time	t_r, t_f	-	15	-	ns
\overline{CS} to SCLK Setup Time	t_{cc}	-	20	-	ns
SCLK to \overline{CS} Hold Time	Note 21 t_{cch}	-	20	-	ns
\overline{CS} Inactive Time	t_{cwh}	-	70	-	ns
SDO Valid to SCLK	Note 21 t_{cdv}	-	60	-	ns
\overline{CS} to SDO High Z	t_{cdz}	-	50	-	ns

Notes: 21. If SPOL = 0, then \overline{CS} should return high no sooner than 20 ns after the 16th rising edge of SCLK during a serial port read.

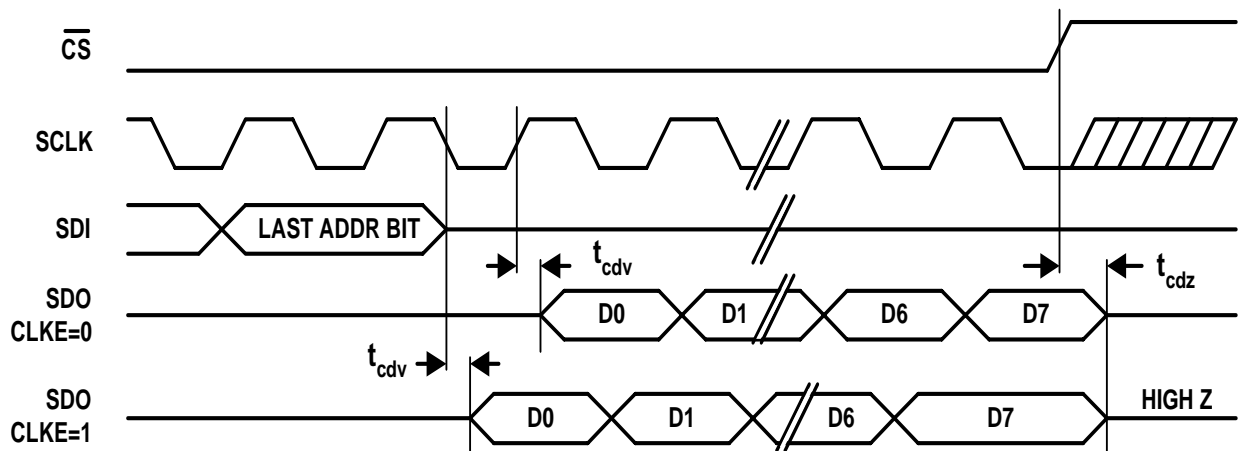

Figure 23. Serial Port Read Timing Diagram

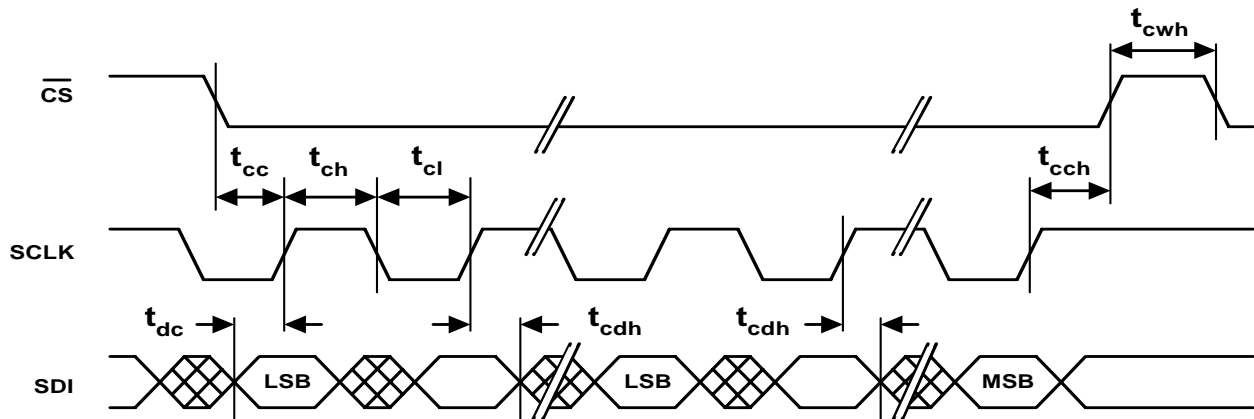

Figure 24. Serial Port Write Timing Diagram

19.11 Switching Characteristics - Parallel Port (Multiplexed Mode)

Parameter	Ref. #	Min.	Typ.	Max	Unit
Pulse Width \overline{AS} or ALE High	1	25	-	-	ns
Muxed Address Setup Time to \overline{AS} or ALE Low	2	10	-	-	ns
Muxed Address Hold Time	3	5	-	-	ns
Delay Time \overline{AS} or ALE to \overline{WR} , \overline{RD} or \overline{DS}	4	5	-	-	ns
\overline{CS} & $\overline{R/\overline{W}}$ Setup Time Before \overline{WR} , \overline{RD} or \overline{DS} Low	5	0	-	-	ns
\overline{CS} & $\overline{R/\overline{W}}$ Hold Time	6	0	-	-	ns
Pulse Width, \overline{WR} , \overline{RD} , or \overline{DS}	7	70	-	-	ns
Write Data Setup Time	8	30	-	-	ns
Write Data Hold Time	9	30	-	-	ns
Output Data Delay Time from \overline{RD} or \overline{DS} Low	10	-	-	100	ns
Read Data Hold Time	11	5	-	-	ns
Delay Time \overline{WR} , \overline{RD} , or \overline{DS} to ALE or \overline{AS} Rise	12	30	-	-	ns
\overline{WR} or \overline{RD} Low to RDY Low	13	-	-	55	ns
\overline{WR} or \overline{RD} Low to RDY High	14	-	-	100	ns
\overline{WR} or \overline{RD} High to RDY HIGH-Z	15	-	-	40	ns
\overline{DS} Low to \overline{ACK} High	16	-	-	65	ns
\overline{DS} Low to \overline{ACK} Low	17	-	-	100	ns
\overline{DS} High to \overline{ACK} HIGH-Z	18	-	-	40	ns

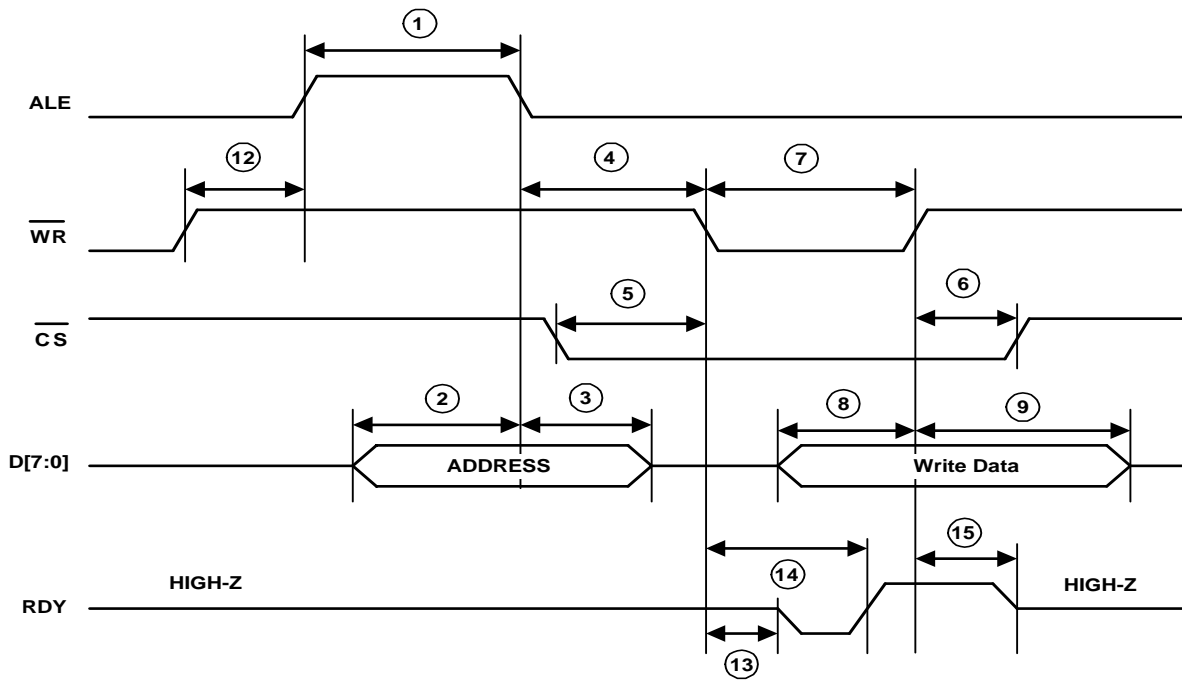

Figure 25. Parallel Port Timing - Write; Intel® Multiplexed Address / Data Bus Mode

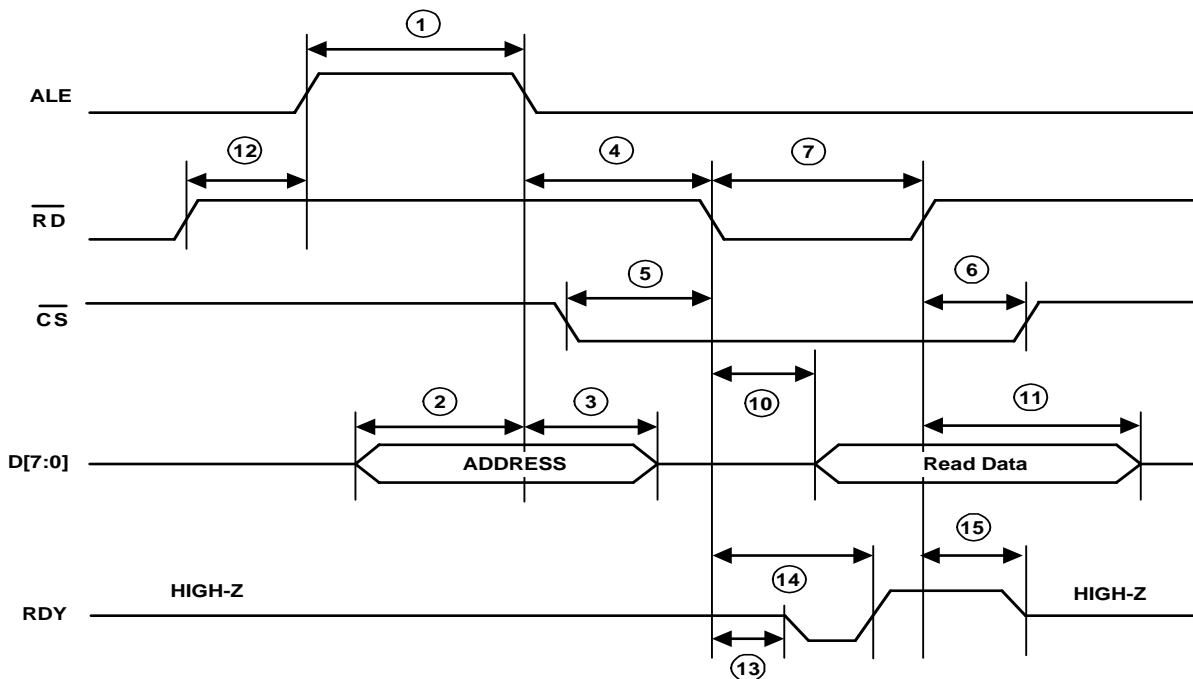

Figure 26. Parallel Port Timing - Read; Intel Multiplexed Address / Data Bus Mode

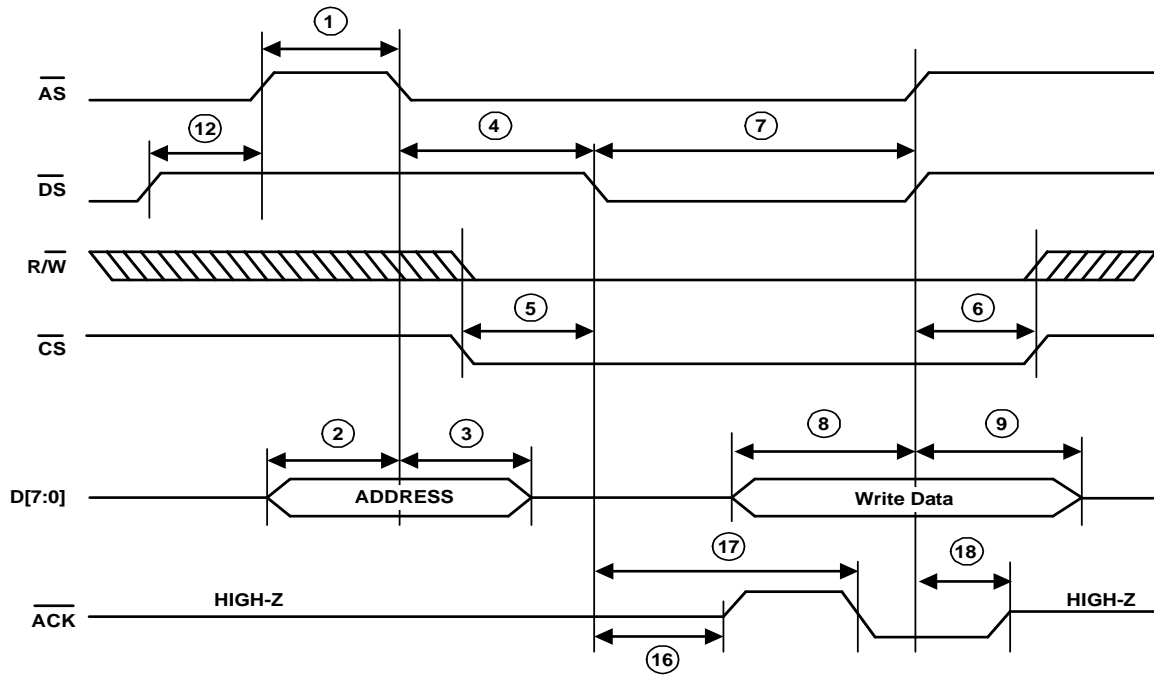

Figure 27. Parallel Port Timing - Write; Motorola® Multiplexed Address / Data Bus Mode

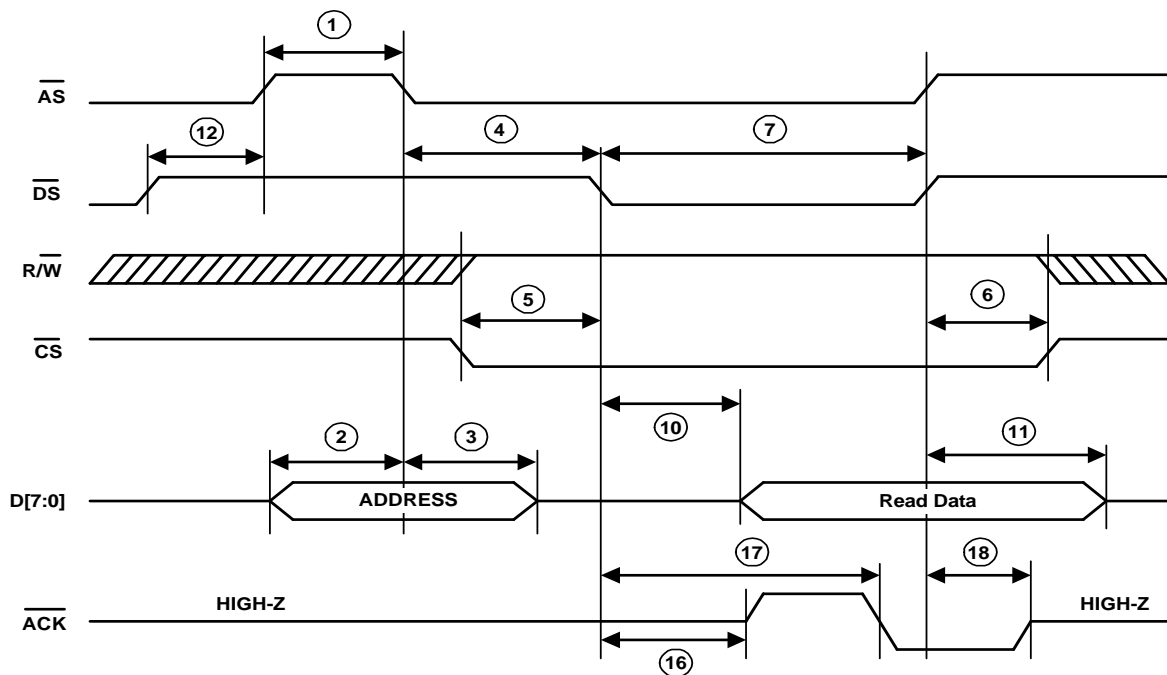

Figure 28. Parallel Port Timing - Read; Motorola Multiplexed Address / Data Bus Mode

19.12 Switching Characteristics- Parallel Port (Non-Multiplexed Mode)

Parameter	Ref. #	Min.	Typ.	Max	Unit
Address Setup Time to \overline{WR} , \overline{RD} or \overline{DS} Low	1	10	-	-	ns
Address Hold Time	2	5	-	-	ns
\overline{CS} & $\overline{R/W}$ Setup Time Before \overline{WR} , \overline{RD} or \overline{DS} Low	3	0	-	-	ns
\overline{CS} & $\overline{R/W}$ Hold Time	4	0	-	-	ns
Pulse Width, \overline{WR} , \overline{RD} , or \overline{DS}	5	70	-	-	ns
Write Data Setup Time	6	30	-	-	ns
Write Data Hold Time	7	30	-	-	ns
Output Data Delay Time from \overline{RD} or \overline{DS}	8	-	-	100	ns
Read Data Hold Time	9	5	-	-	ns
\overline{WR} or \overline{RD} Low to RDY Low	10	-	-	55	ns
\overline{WR} , \overline{RD} or \overline{DS} Low to RDY High	11	-	-	100	ns
\overline{WR} , \overline{RD} or \overline{DS} High to RDY HIGH-Z	12	-	-	40	ns
\overline{DS} Low to \overline{ACK} High	13	-	-	65	ns
\overline{DS} Low to \overline{ACK} Low	14	-	-	100	ns
\overline{DS} High to \overline{ACK} HIGH-Z	15	-	-	40	ns

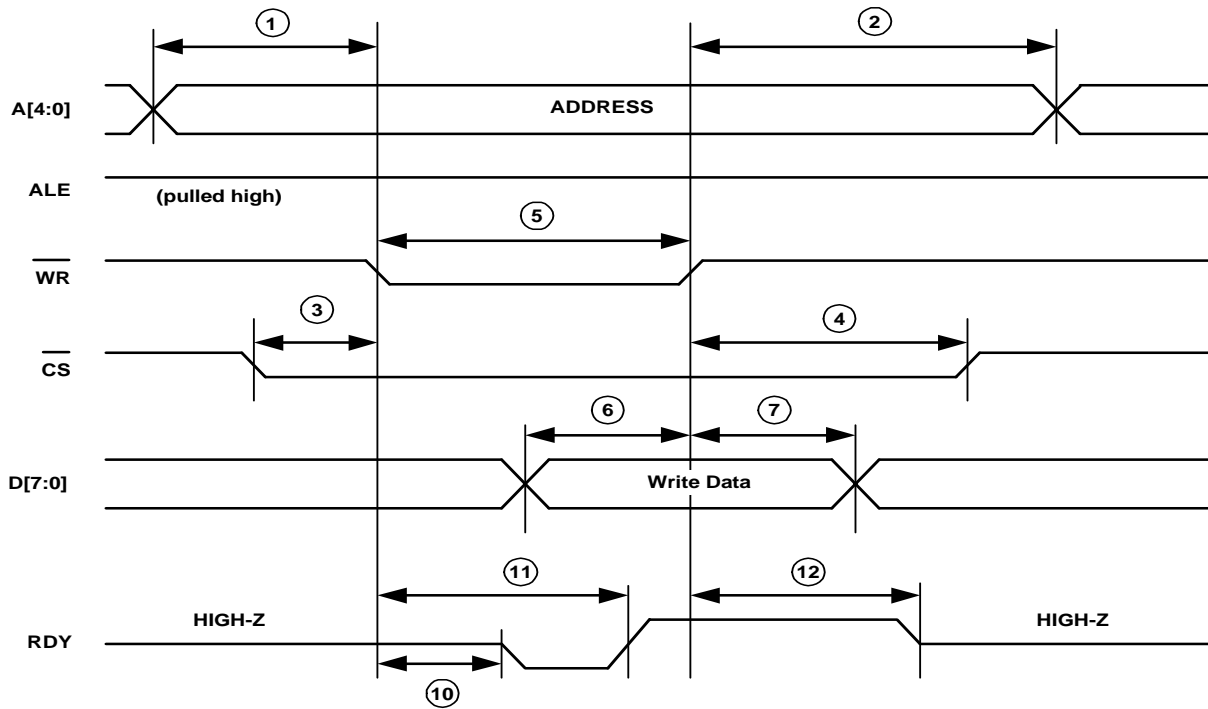

Figure 29. Parallel Port Timing - Write; Intel Non-Multiplexed Address / Data Bus Mode

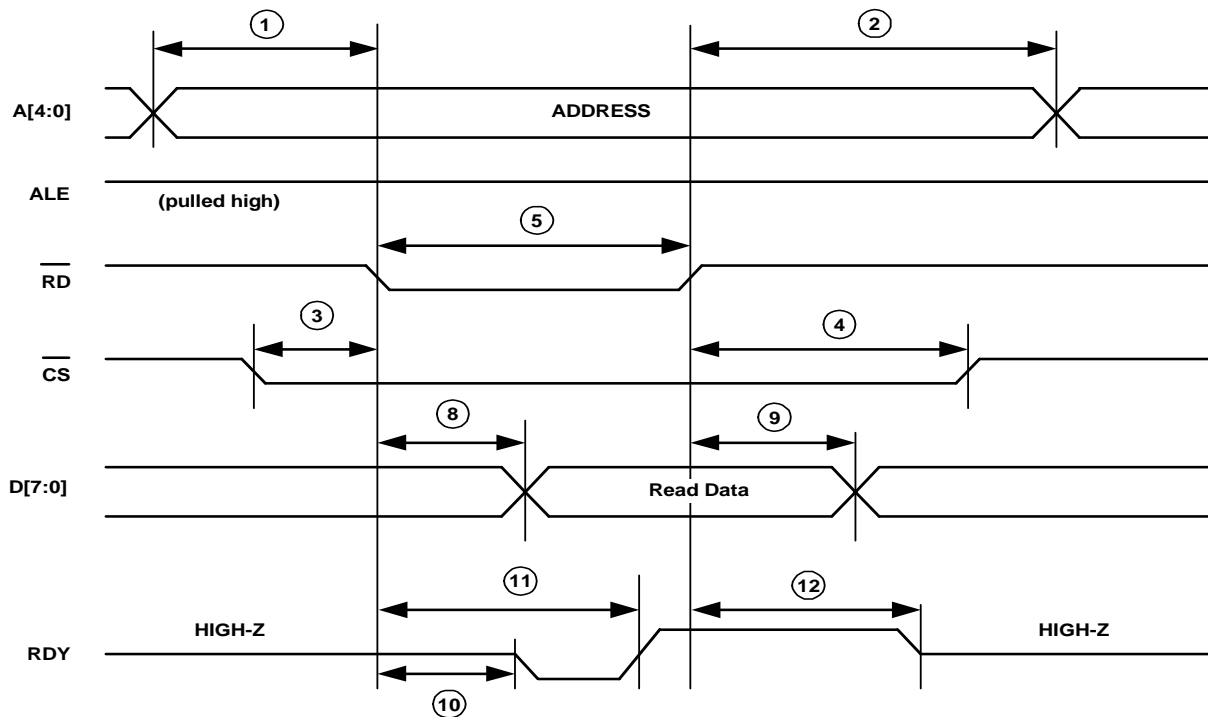

Figure 30. Parallel Port Timing - Read; Intel Non-Multiplexed Address / Data Bus Mode

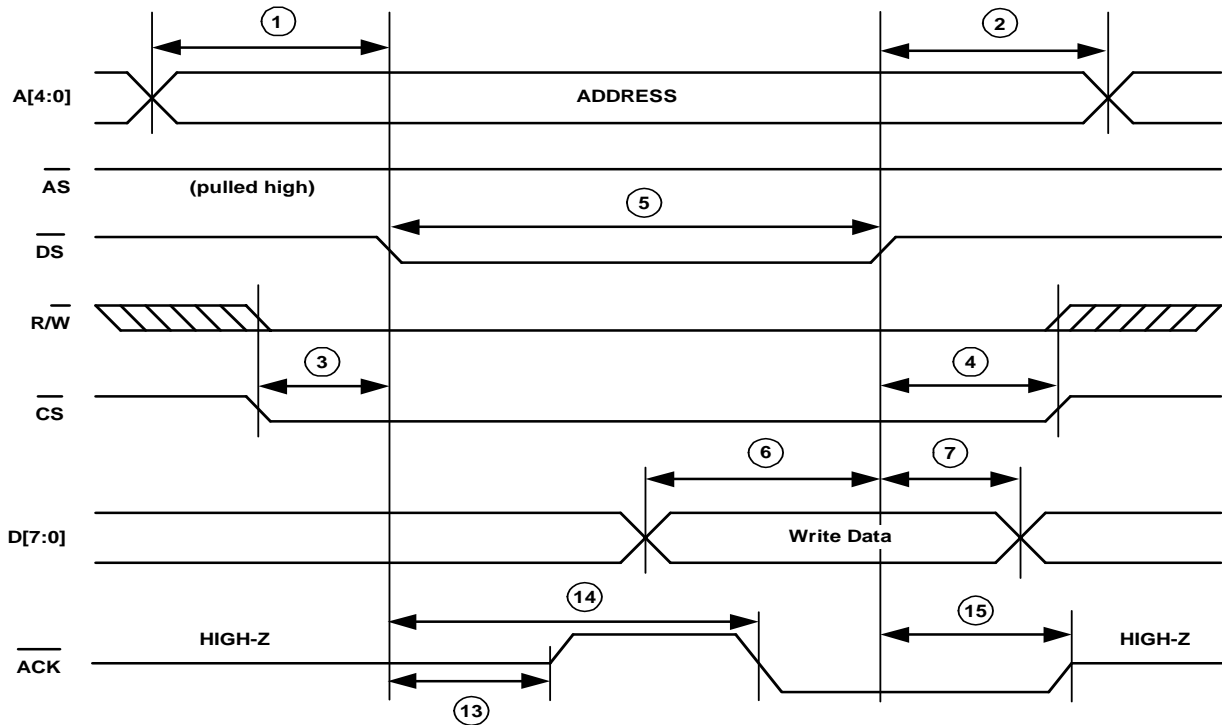

Figure 31. Parallel Port Timing - Write; Motorola Non-Multiplexed Address / Data Bus Mode

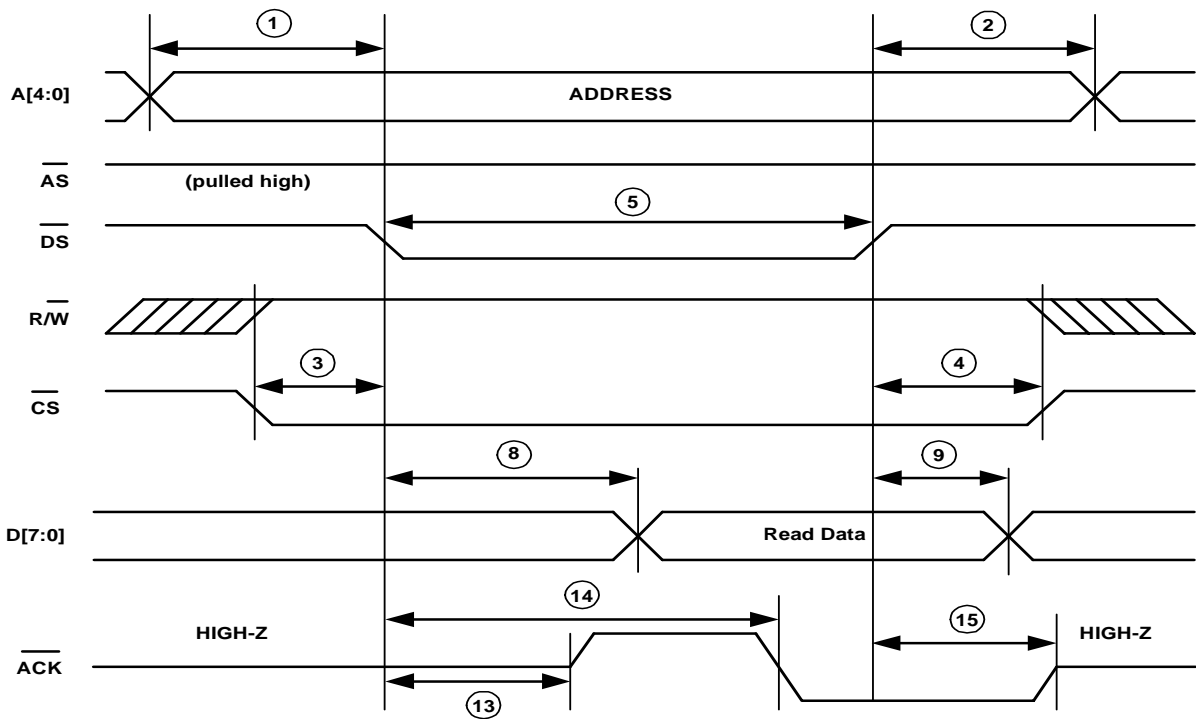
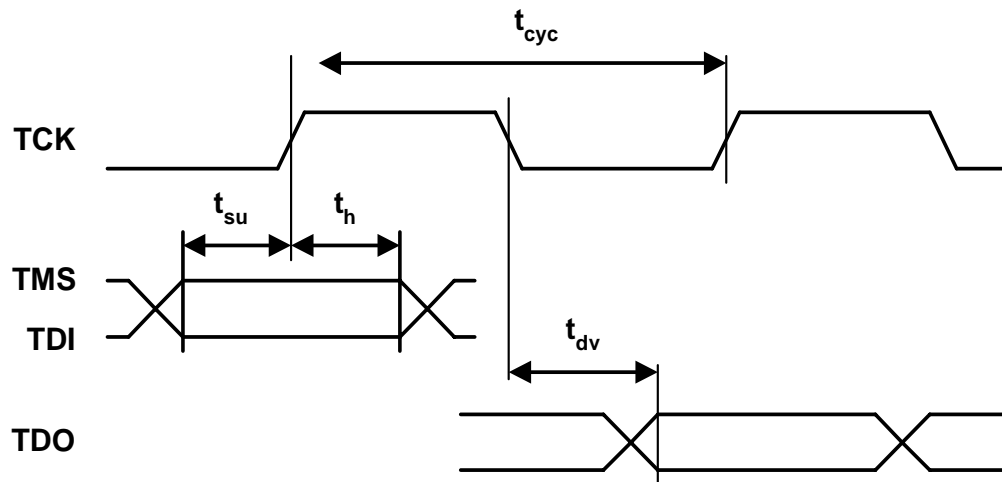

Figure 32. Parallel Port Timing - Read; Motorola Non-Multiplexed Address / Data Bus Mode

19.13 Switching Characteristics - JTAG

Parameter	Symbol	Min.	Max	Units
Cycle Time	t_{cyc}	200	-	ns
TMS/TDI to TCK Rising Setup Time	t_{su}	50	-	ns
TCK Rising to TMS/TDI Hold Time	t_h	50	-	ns
TCK Falling to TDO Valid	t_{dv}	-	70	ns

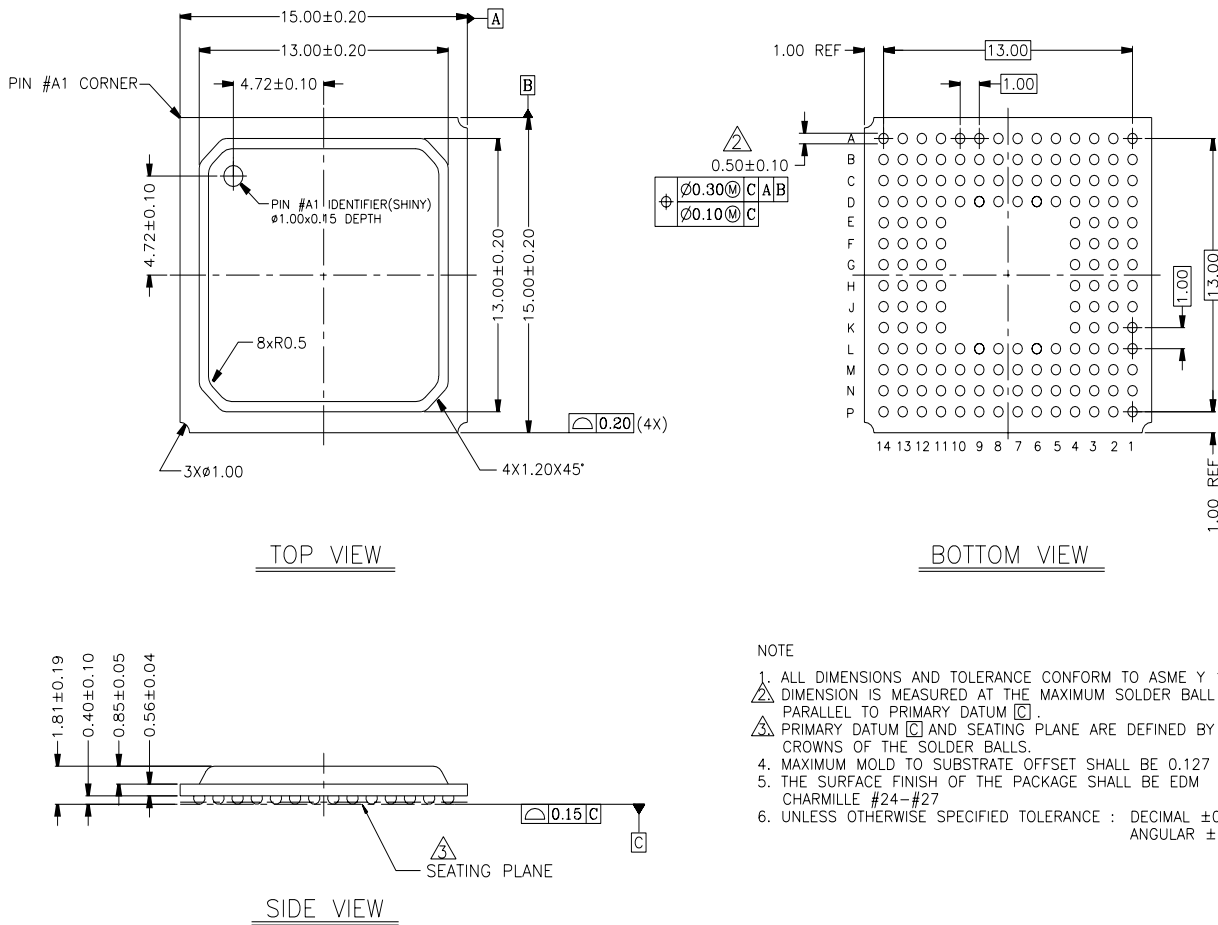

Figure 33. JTAG Switching Characteristics

20. COMPLIANT RECOMMENDATIONS AND SPECIFICATIONS

ETSI ETS 300-011	ITU-T G.732
ETSI ETS 300-166	ITU-T G.735
ETSI ETS 300-233	ITU-T G.736
ETSI TBR 12/13	ITU-T G.742
IEEE 1149.1	ITU-T G.772
ITU-T I.431	ITU-T G.775
ITU-T G.703	ITU-T G.783
ITU-T G.704	ITU-T G.823
ITU-T G.706	ITU-T O.151
	OFTTEL OTR-001

21. 160-BALL FBGA PACKAGE DIMENSIONS

160-Ball FBGA (4 layer)



- NOTE
1. ALL DIMENSIONS AND TOLERANCE CONFORM TO ASME Y 14.5M-1994.
 2. DIMENSION IS MEASURED AT THE MAXIMUM SOLDER BALL DIAMETER, PARALLEL TO PRIMARY DATUM [C].
 3. PRIMARY DATUM [C] AND SEATING PLANE ARE DEFINED BY THE SPHERICAL CROWNS OF THE SOLDER BALLS.
 4. MAXIMUM MOLD TO SUBSTRATE OFFSET SHALL BE 0.127
 5. THE SURFACE FINISH OF THE PACKAGE SHALL BE EDM CHARMILLE #24-#27
 6. UNLESS OTHERWISE SPECIFIED TOLERANCE : DECIMAL ±0.05
 ANGULAR ±2°

Figure 34. 160-Ball FBGA Package Drawing

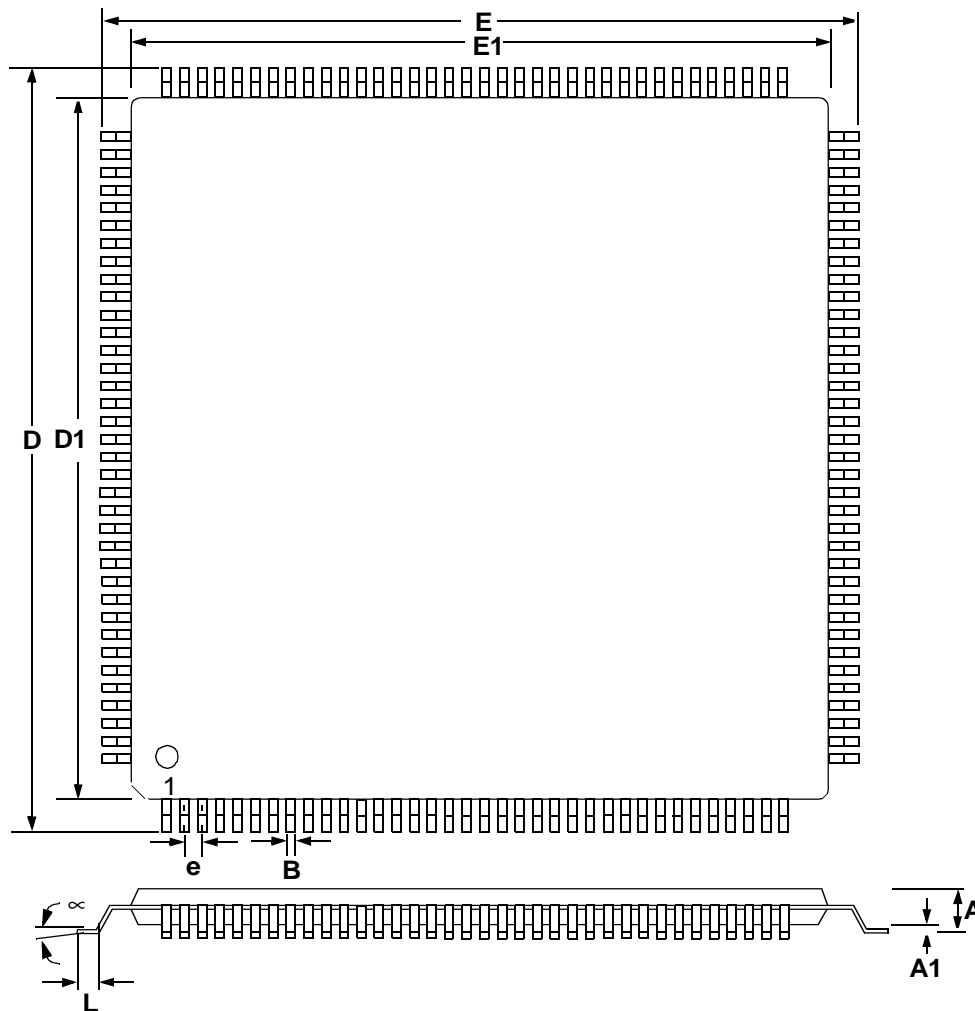
22. 144-PIN LQFP PACKAGE DIMENSIONS

Figure 35. 144-Pin LQFP Package Drawing
Table 16. 144-Pin Package Dimensions

DIM	INCHES			MILLIMETERS		
	MIN	NOM	MAX	MIN	NOM	MAX
A	---	0.55	0.063	---	1.40	1.60
A1	0.002	0.004	0.006	0.05	0.10	0.15
B	0.007	0.008	0.011	0.17	0.20	0.27
D	0.854	0.866 BSC	0.878	21.70	22.0 BSC	22.30
D1	0.783	0.787 BSC	0.791	19.90	20.0 BSC	20.10
E	0.854	0.866 BSC	0.878	21.70	22.0 BSC	22.30
E1	0.783	0.787 BSC	0.791	19.90	20.0 BSC	20.10
e*	0.016	0.020	0.024	0.40	0.50 BSC	0.60
∞	0.000°	4°	7.000°	0.00°	4°	7.00°
L	0.018	0.024	0.030	0.45	0.60	0.75

* Nominal pin pitch is 0.50 mm Controlling dimension is mm. JEDEC Designation: MS022

Looking for pricing, stock, or lifecycle information?

Click below to explore more details on WIN SOURCE:

 [View CS61880-IQZR on WIN SOURCE](#)

 [Cirrus Logic Inc. Information](#)

Optimize Your Supply Chain with WIN SOURCE Solutions

-  Global Sourcing Solution
-  Obsolete Management
-  Cost Control Management
-  Shortage Management
-  Alternative Solution
-  Excess Inventory Management