



**THE DATASHEET OF
ISL83387EIVZ**



ISL83387E

±15kV ESD Protected, +3V to +5.5V, 1Microamp, 250kbps, RS-232 Transceivers with Enhanced Automatic Powerdown

The [ISL83387E](#) is a 3.0V to 5.5V powered RS-232 transceiver that meets EIA/TIA-232 and V.28/V.24 specifications, even at $V_{CC} = 3.0V$. Additionally, it provides ±15kV ESD protection (IEC61000-4-2 Air Gap and Human Body Model) on transmitter outputs and receiver inputs (RS-232 pins). Targeted applications are industrial laptop computers, Palmtops, PDAs, and notebooks where the low operational power consumption and even lower standby power consumption is critical. Efficient on-chip charge pumps coupled with manual and enhanced automatic powerdown functions reduce the standby supply current to a 1µA trickle. The TSSOP packaging and the use of small, low value capacitors ensure board space savings. Data rates greater than 250kbps are ensured at worst case load conditions.

The ISL83387E features a V_L pin that adjusts the logic pin output levels and input thresholds to values compatible with the V_{CC} powering the external logic (for example, a UART).

The ISL83387E includes an enhanced automatic power-down function that powers down the on-chip power-supply and driver circuits. Automatic powerdown occurs when all receiver and transmitter inputs detect no signal transitions for a period of 30 seconds. The ISL83387E powers back up automatically, when it senses a transition on any transmitter or receiver input.

[Table 1](#) summarizes the features of the ISL83387E and Application Note AN9863 summarizes the features of each device comprising the 3V RS-232 family.

Related Literature

For a full list of related documents, visit our website:

- [ISL83387E](#) device page

Features

- V_L supply pin for compatibility with mixed voltage systems
- ESD protection for RS-232 I/O pins to ±15kV (IEC61000)
- Low power, pin compatible upgrade for MAX3387E
- Manual and enhanced automatic powerdown features
- Meets EIA/TIA-232 and V.28/V.24 specifications at 3V
- On-chip charge pumps require only four external 0.1µF capacitors
- Receivers stay active in powerdown
- Very low supply current: 300µA
- Assured minimum data rate: 250kbps
- Wide power supply range: Single +3V to +5.5V
- Low supply current in powerdown state: < 1µA
- Pb-Free (RoHS compliant)

Applications

- Any system requiring RS-232 communication ports
 - Battery powered, hand-held, and portable equipment
 - Industrial laptops, Palmtops, and PDAs
 - Digital cameras

Table 1. Summary of Features

Part Number	No. of Tx.	No. of Rx.	Data Rate (kbps)	Rx. Enable Function?	V_L Logic Supply Pin?	Manual Power-Down?	Enhanced Automatic Powerdown Function?
ISL83387E	3	3	250	No	Yes	Yes	Yes

Contents

1. Overview	3
1.1 Typical Operating Circuit	3
1.2 Ordering Information	3
1.3 Pin Configuration	4
1.4 Pin Descriptions	4
2. Specifications	5
2.1 Absolute Maximum Ratings	5
2.2 Thermal Information	5
2.3 Recommended Operating Conditions	5
2.4 Electrical Specifications	5
3. Typical Performance Curves	8
4. Application Information	9
4.1 Charge-Pump	9
4.1.1 Charge-Pump Abs Max Ratings	9
4.2 Transmitters	10
4.3 Receivers	11
4.4 Low Power Operation	11
4.5 Powerdown Functionality	11
4.5.1 Software Controlled (Manual) Powerdown	11
4.5.2 <u>INVALID</u> Output	12
4.5.3 Enhanced Automatic Powerdown	13
4.5.4 Emulating Standard Automatic Powerdown	14
4.5.5 Hybrid Automatic Powerdown Options	15
4.6 V_L Logic Supply Input	15
4.7 Capacitor Selection	15
4.8 Power Supply Decoupling	15
4.9 Transmitter Outputs when Exiting Power-Down	15
4.10 High Data Rates	16
4.11 Interconnection with 3V and 5V Logic	17
5. $\pm 15\text{kV}$ ESD Protection	18
5.1 Human Body Model (HBM) Testing	18
5.2 IEC61000-4-2 Testing	18
5.2.1 Air-Gap Discharge Test Method	18
5.2.2 Contact Discharge Test Method	18
6. Die Characteristics	19
7. Revision History	20
8. Package Outline Drawing	21

1. Overview

1.1 Typical Operating Circuit

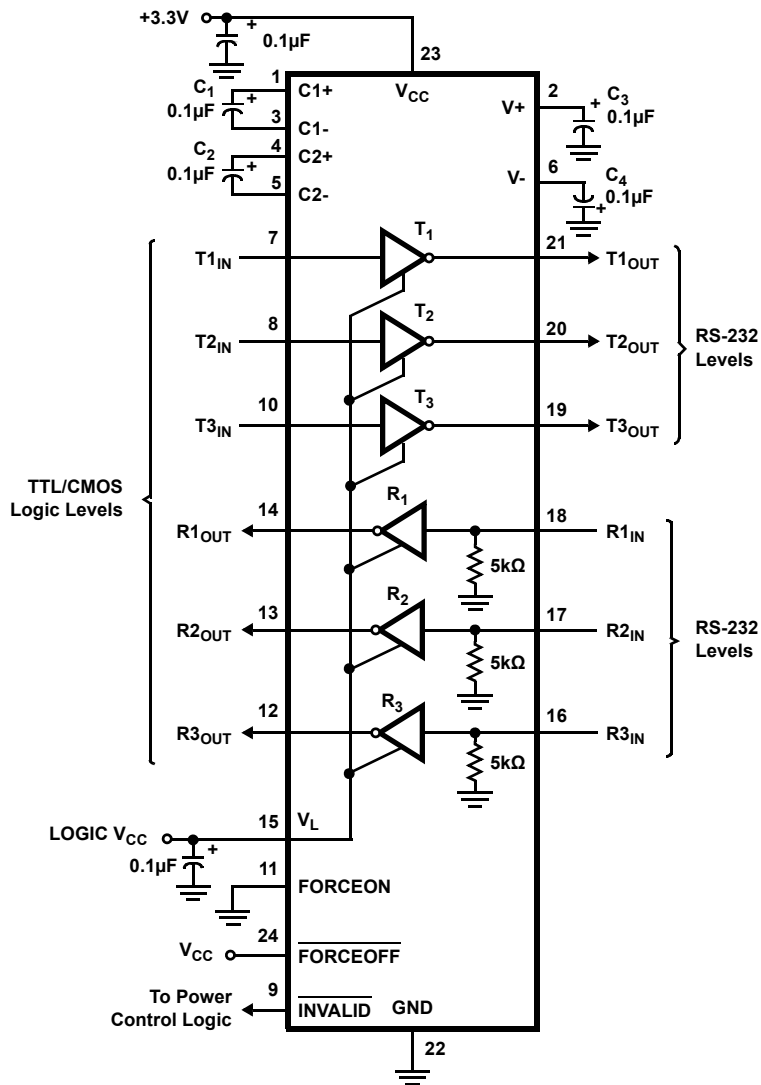

Figure 1. Typical Operating Circuit

1.2 Ordering Information

Part Number (Notes 2, 3)	Part Marking	Temp. Range (°C)	Tape and Reel (Units) (Note 1)	Package (RoHS Compliant)	Pkg. Dwg. #.
ISL83387EIVZ	83387EIVZ	-40 to 85	-	24 Ld TSSOP	M24.173
ISL83387EIVZ-T	83387EIVZ	-40 to 85	2.5k	24 Ld TSSOP	M24.173

Notes:

1. See [TB347](#) for details about reel specifications.
2. Pb-free plus anneal products employ special Pb-free material sets; molding compounds/die attach materials and 100% matte tin plate termination finish, which are RoHS compliant and compatible with both SnPb and Pb-free soldering operations. Pb-free products are MSL classified at Pb-free peak reflow temperatures that meet or exceed the Pb-free requirements of IPC/JEDEC J-STD-020.
3. For Moisture Sensitivity Level (MSL), see the [ISL83387E](#) device page. For more information about MSL, see [TB363](#).

1.3 Pin Configuration

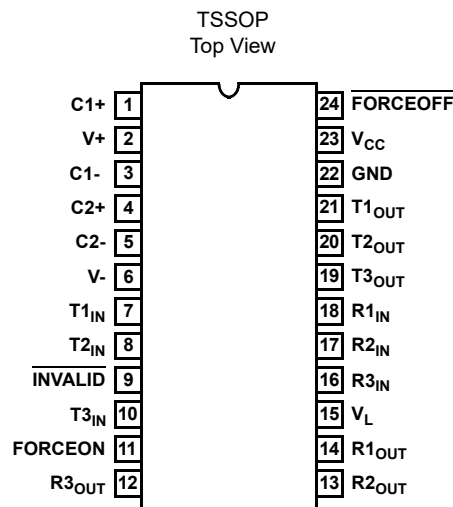

1.4 Pin Descriptions

Pin Name	Function
V _{CC}	System power supply input (3.0V to 5.5V).
V+	Internally generated positive transmitter supply (+5.5V).
V-	Internally generated negative transmitter supply (-5.5V).
GND	Ground connection.
C1+	External capacitor (voltage doubler) is connected to this lead.
C1-	External capacitor (voltage doubler) is connected to this lead.
C2+	External capacitor (voltage inverter) is connected to this lead.
C2-	External capacitor (voltage inverter) is connected to this lead.
T _{IN}	TTL/CMOS compatible transmitter Inputs. The switching point is a function of the V _L voltage.
T _{OUT}	±15kV ESD Protected, RS-232 level (nominally ±5.5V) transmitter outputs.
R _{IN}	±15kV ESD Protected, RS-232 compatible receiver inputs.
R _{OUT}	TTL/CMOS level receiver outputs. Swings between GND and V _L .
V _L	Logic-Level Supply. All TTL/CMOS inputs and outputs are powered by this supply.
INVALID	Active low output that indicates if no valid RS-232 levels are present on any receiver input. Swings between GND and V _L .
FORCEOFF	Active low to shut down transmitters and on-chip power supply that overrides any automatic circuitry and FORCEON (see Table 5 on page 11). The switching point is a function of the V _L voltage.
FORCEON	Active high input to override automatic powerdown circuitry, which keeps transmitters active. (FORCEOFF must be high). The switching point is a function of the V _L voltage.

2. Specifications

2.1 Absolute Maximum Ratings

Parameter	Minimum	Maximum	Unit
V _{CC} to Ground	-0.3	6	V
V _L to Ground	-0.3	7	V
V+ to Ground	-0.3	7	V
V- to Ground	+0.3	-7	V
V+ to V-		14	V
Input Voltages			
T _{IN} , FORCEON, FORCEOFF	-0.3	6	V
R _{IN}		±25	V
Output Voltages			
T _{OUT}		±13.2	V
R _{OUT} , INVALID	-0.3	V _L + 0.3	V
Short-Circuit Duration			
T _{OUT}		Continuous	
ESD Rating	(See "ESD Performance" on page 7)		

CAUTION: Do not operate at or near the maximum ratings listed for extended periods of time. Exposure to such conditions can adversely impact product reliability and result in failures not covered by warranty.

2.2 Thermal Information

Thermal Resistance (Typical, Note 4)	θ _{JA} (°C/W)
24 Ld TSSOP Package	140

Note:

4. θ_{JA} is measured with the component mounted on a low-effective thermal conductivity test board in free air. See [TB379](#).

Parameter	Minimum	Maximum	Unit
Maximum Junction Temperature (Plastic Package)		+150	°C
Maximum Storage Temperature Range	-65	+150	°C
Pb-Free Reflow Profile	see TB493		

2.3 Recommended Operating Conditions

Parameter	Minimum	Maximum	Unit
Temperature Range	-40	+85	°C

2.4 Electrical Specifications

Test conditions: V_{CC} = 3V to 5.5V, C₁ - C₄ = 0.1µF, V_L = V_{CC}; unless otherwise specified. Typical values are at T_A = 25°C, V_{CC} = V_L = 3.3V

Parameter	Test Conditions	Temp (°C)	Min	Typ	Max	Unit
DC Characteristics						
Supply Current, Automatic Power-Down	All R _{IN} Open, FORCEON = GND, FORCEOFF = V _{CC}	25	-	1	10	µA
Supply Current, Powerdown	FORCEOFF = GND	25	-	1	10	µA

Test conditions: $V_{CC} = 3V$ to $5.5V$, $C_1 - C_4 = 0.1\mu F$, $V_L = V_{CC}$; unless otherwise specified. Typical values are at $T_A = 25^\circ C$, $V_{CC} = V_L = 3.3V$

Parameter	Test Conditions	Temp (°C)	Min	Typ	Max	Unit	
Supply Current, Automatic Power-Down Disabled	All Outputs Unloaded, $\overline{FORCEON} = \overline{FORCEOFF} = V_{CC}$, $V_{CC} = 3.15V$	25	-	0.3	1	mA	
Logic and Transmitter Inputs							
Input Logic Threshold Low	T_{IN} , $\overline{FORCEON}$, $\overline{FORCEOFF}$	$V_L = 3.3V$ or $5V$	Full	-	-	0.8	V
		$V_L = 2.5V$	Full	-	-	0.6	V
Input Logic Threshold High	T_{IN} , $\overline{FORCEON}$, $\overline{FORCEOFF}$	$V_L = 5V$	Full	2.4	-	-	V
		$V_L = 3.3V$	Full	2.0	-	-	V
		$V_L = 2.5V$	Full	1.4	-	-	V
		$V_L = 1.8V$	25	-	0.9	-	-
Transmitter Input Hysteresis		25	-	0.5	-	V	
Input Leakage Current	T_{IN} , $\overline{FORCEON}$, $\overline{FORCEOFF}$	Full	-	± 0.01	± 1.0	μA	
Receiver Outputs							
Output Voltage Low	$I_{OUT} = 1.6mA$	Full	-	-	0.4	V	
Output Voltage High	$I_{OUT} = -1.0mA$	Full	$V_L - 0.6$	$V_L - 0.1$	-	V	
Receiver Inputs							
Input Voltage Range		Full	-25	-	25	V	
Input Threshold Low	$V_{CC} = V_L = 5.0V$	25	0.8	1.5	-	V	
	$V_{CC} = V_L = 3.3V$	25	0.6	1.2	-	V	
Input Threshold High	$V_{CC} = V_L = 5.0V$	25	-	1.8	2.4	V	
	$V_{CC} = V_L = 3.3V$	25	-	1.5	2.4	V	
Input Hysteresis		25	-	0.5	-	V	
Input Resistance		25	3	5	7	k Ω	
Transmitter Outputs							
Output Voltage Swing	All Transmitter Outputs Loaded with $3k\Omega$ to Ground	Full	± 5.0	± 5.4	-	V	
Output Resistance	$V_{CC} = V_+ = V_- = 0V$, Transmitter Output = $\pm 2V$	Full	300	10M	-	Ω	
Output Short-Circuit Current	$V_{OUT} = 0V$	Full	-	± 35	± 60	mA	
Output Leakage Current	$V_{OUT} = \pm 12V$, $V_{CC} = 0V$ or $3V$ to $5.5V$ Automatic Powerdown or $\overline{FORCEOFF} = GND$	Full	-	-	± 25	μA	
Enhanced Automatic Powerdown ($\overline{FORCEON} = GND$, $\overline{FORCEOFF} = V_{CC}$)							
Receiver Input Thresholds to INVALID High	See Figure 10	Full	-2.7	-	2.7	V	
Receiver Input Thresholds to INVALID Low	See Figure 10	Full	-0.3	-	0.3	V	
INVALID Output Voltage Low	$I_{OUT} = 1.6mA$	Full	-	-	0.4	V	
INVALID Output Voltage High	$I_{OUT} = -1.0mA$	Full	$V_L - 0.6$	-	-	V	
Receiver Positive or Negative Threshold to INVALID High Delay (t_{INVH})	See Figure 13	25	-	1	-	μs	
Receiver Positive or Negative Threshold to INVALID Low Delay (t_{INVL})	See Figure 13	25	-	30	-	μs	
Receiver or Transmitter Edge to Transmitters Enabled Delay (t_{WU})	Note 5 , see Figure 13	25	-	100	-	μs	

Test conditions: $V_{CC} = 3V$ to $5.5V$, $C_1 - C_4 = 0.1\mu F$, $V_L = V_{CC}$; unless otherwise specified. Typical values are at $T_A = 25^\circ C$, $V_{CC} = V_L = 3.3V$

Parameter	Test Conditions	Temp (°C)	Min	Typ	Max	Unit	
Receiver or Transmitter Edge to Transmitters Disabled Delay ($t_{AUTOPWDN}$)	Note 5 , see Figure 13	Full	15	30	60	sec	
Timing Characteristics							
Maximum Data Rate	$R_L = 3k\Omega$, $C_L = 1000pF$, One Transmitter Switching	Full	250	500	-	kbps	
Receiver Propagation Delay	Receiver Input to Receiver Output, $C_L = 150pF$	t_{PHL}	25	-	0.15	-	μs
		t_{PLH}	25	-	0.15	-	μs
Time to Exit Powerdown	$T_X V_{OUT} \geq 3.7V$	25	-	100	-	μs	
Transmitter Skew	$t_{PHL} - t_{PLH}$	25	-	100	-	ns	
Receiver Skew	$t_{PHL} - t_{PLH}$	25	-	50	-	ns	
Transition Region Slew Rate	$V_{CC} = 3.3V$, $R_L = 3k\Omega$ to $7k\Omega$, Measured From $3V$ to $-3V$ or $-3V$ to $3V$	$C_L = 150pF$ to $1000pF$	25	6	18	30	$V/\mu s$
		$C_L = 150pF$ to $2500pF$	25	4	13	30	$V/\mu s$
ESD Performance							
RS-232 Pins (T_{OUT} , R_{IN})	Human Body Model	25	-	± 15	-	kV	
	IEC61000-4-2 Air Gap Discharge	25	-	± 15	-	kV	
	IEC61000-4-2 Contact Discharge	25	-	± 8	-	kV	

Note:

5. An "edge" is defined as a transition through the transmitter or receiver input thresholds.

3. Typical Performance Curves

$V_{CC} = V_L = 3.3V, T_A = 25^\circ C$

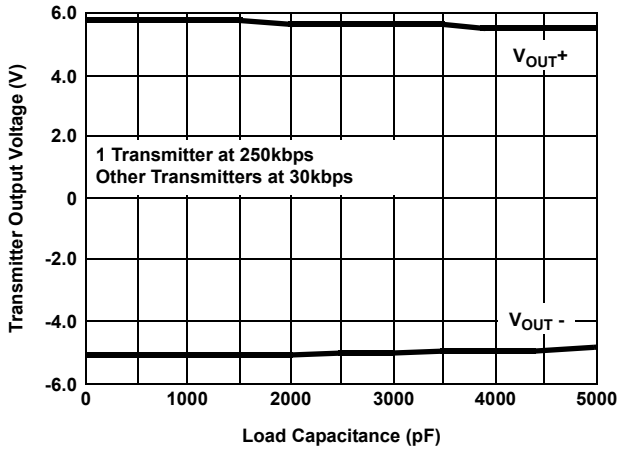

Figure 2. Transmitter Output Voltage vs Load Capacitance

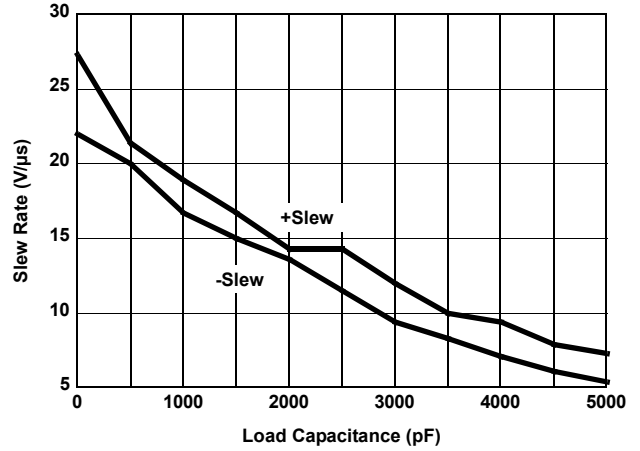

Figure 3. Slew Rate vs Load Capacitance

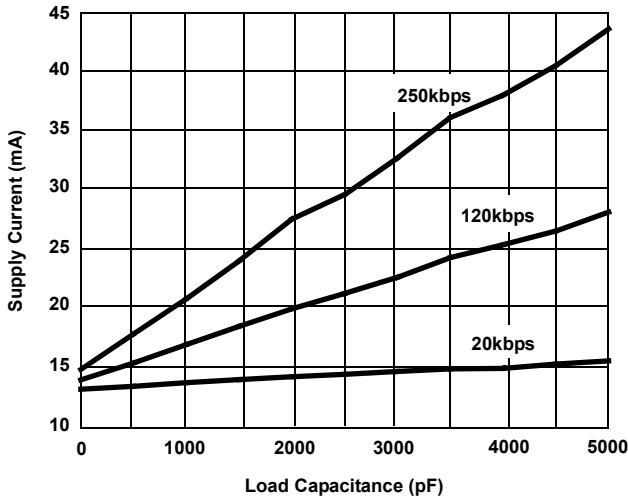

Figure 4. Supply Current vs Load Capacitance When Transmitting Data

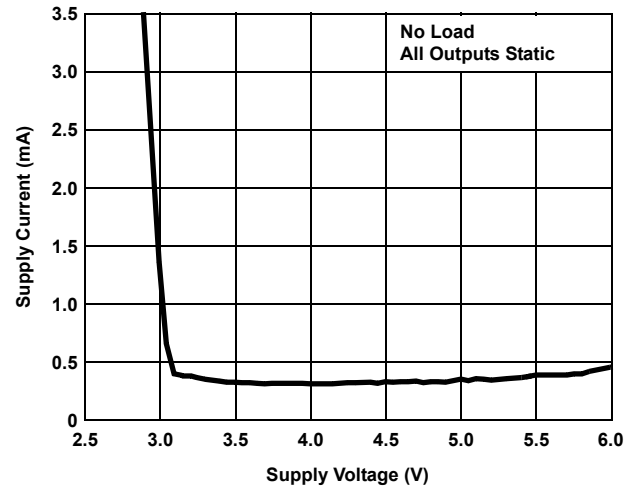

Figure 5. Supply Current vs Supply Voltage

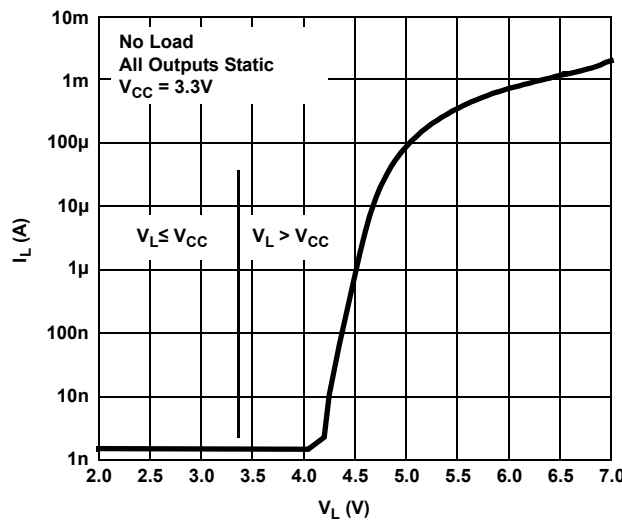

Figure 6. V_L Supply Current vs V_L Voltage

4. Application Information

The ISL83387E operates from a single +3V to +5.5V supply, ensures a 250kbps minimum data rate, requires only four small external 0.1 μ F capacitors, features low power consumption, and meets all EIA RS-232C and V.28 specifications.

4.1 Charge-Pump

The ISL83387E uses regulated on-chip dual charge-pumps as voltage doublers, and voltage inverters to generate ± 5.5 V transmitter supplies from a V_{CC} supply as low as 3.0V. The charge-pumps allow the device to maintain RS-232 compliant output levels over the $\pm 10\%$ tolerance range of 3.3V powered systems. The efficient on-chip power supplies require only four small, external 0.1 μ F capacitors for the voltage doubler and inverter functions over the full V_{CC} range. See "[Capacitor Selection](#)" on page 15 and [Table 6 on page 15](#) for capacitor recommendations for other operating conditions. The charge-pumps operate discontinuously (turning off when the V+ and V- supplies are pumped up to the nominal values), providing significant power savings.

4.1.1 Charge-Pump Abs Max Ratings

These 3V to 5V RS-232 transceivers have been fully characterized for 3.0V to 3.6V operation and for critical points at 4.5V to 5.5V operation. Furthermore, load conditions were favorable using static logic states only.

The specified maximum values for V+ and V- are +7V and -7V, respectively. These limits apply for V_{CC} values set to 3.0V and 3.6V (see [Table 2](#)). For V_{CC} values set to 4.5V and 5.5V, the maximum values for V+ and V- can approach +9V and -7V, respectively ([Table 3 on page 10](#)). The breakdown characteristics for V+ and V- were measured with ± 13 V.

Table 2. V+ and V- Values for $V_{CC} = 3.0$ V to 3.6V

C ₁ (μ F)	C ₂ , C ₃ , C ₄ (μ F)	Load	T1IN (Logic State)	V+ (V)		V- (V)	
				V _{CC} = 3.0V	V _{CC} = 3.6V	V _{CC} = 3.0V	V _{CC} = 3.6V
0.1	0.1	Open	H	5.80	6.56	-5.60	-5.88
			L	5.80	6.56	-5.60	-5.88
			2.4kbps	5.80	6.56	-5.60	-5.88
		3k Ω // 1000pF	H	5.88	6.60	-5.56	-5.92
			L	5.76	6.36	-5.56	-5.76
			2.4kbps	6.00	6.64	-5.64	-5.96
0.047	0.33	Open	H	5.68	6.00	-5.60	-5.60
			L	5.68	6.00	-5.60	-5.60
			2.4kbps	5.68	6.00	-5.60	-5.60
		3k Ω // 1000pF	H	5.76	6.08	-5.64	-5.64
			L	5.68	6.04	-5.60	-5.60
			2.4kbps	5.84	6.16	-5.64	-5.72
1	1	Open	H	5.88	6.24	-5.60	-5.60
			L	5.88	6.28	-5.60	-5.64
			2.4kbps	5.80	6.20	-5.60	-5.60
		3k Ω // 1000pF	H	5.88	6.44	-5.64	-5.72
			L	5.88	6.04	-5.64	-5.64
			2.4kbps	5.92	6.40	-5.64	-5.64

Table 3. V+ and V- Values for $V_{CC} = 4.5V$ to $5.5V$

C ₁ (μF)	C ₂ , C ₃ , C ₄ (μF)	Load	T1IN (Logic State)	V+ (V)		V- (V)	
				V _{CC} = 4.5V	V _{CC} = 5.5V	V _{CC} = 4.5V	V _{CC} = 5.5V
0.1	0.1	Open	H	7.44	8.48	-6.16	-6.40
			L	7.44	8.48	-6.16	-6.44
			2.4kbps	7.44	8.48	-6.17	-6.44
		3kΩ // 1000pF	H	7.76	8.88	-6.36	-6.72
			L	7.08	8.00	-5.76	-5.76
			2.4kbps	7.76	8.84	-6.40	-6.64
0.047	0.33	Open	H	6.44	6.88	-5.80	-5.88
			L	6.48	6.88	-5.84	-5.88
			2.4kbps	6.44	6.88	-5.80	-5.88
		3kΩ // 1000pF	H	6.64	7.28	-5.92	-6.04
			L	6.24	6.60	-5.52	-5.52
			2.4kbps	6.72	7.16	-5.92	-5.96
1	1	Open	H	6.84	7.60	-5.76	-5.76
			L	6.88	7.60	-5.76	-5.76
			2.4kbps	6.92	7.56	-5.72	-5.76
		3kΩ // 1000pF	H	7.28	8.16	-5.80	-5.92
			L	6.44	6.84	-5.64	-6.84
			2.4kbps	7.08	7.76	-5.80	-5.80

The resulting new maximum voltages at V+ and V- are listed in [Table 4](#).

Table 4. New Measured Withstanding Voltages

V+, V- to Ground	±13V
V+ to V-	20V

4.2 Transmitters

The transmitters are proprietary, low dropout, inverting drivers that translate TTL/CMOS inputs to EIA/TIA-232 output levels. The transmitters couple with the on-chip ±5.5V supplies to deliver true RS-232 levels across a wide range of single supply system voltages.

All transmitter outputs disable and assume a high impedance state when the device enters the powerdown mode (see [Table 5 on page 11](#)). The outputs can be driven to ±12V when disabled.

The ISL83387E ensures a 250kbps data rate for full load conditions (3kΩ and 1000pF), $V_{CC} \geq 3.0V$, with one transmitter operating at full speed. Under more typical conditions of $V_{CC} \geq 3.3V$, $R_L = 3k\Omega$, and $C_L = 250pF$, one transmitter easily operates at 1.25Mbps.

The transmitter input threshold is set by the voltage applied to the V_L supply pin. Transmitter inputs float if they remain unconnected (there are no pull-up resistors), and they can cause I_{CC} increases. Connect unused inputs to GND for best performance.

4.3 Receivers

The ISL83387E contains standard inverting receivers that convert RS-232 signals to CMOS output levels and accept inputs up to $\pm 25V$ while presenting the required $3k\Omega$ to $7k\Omega$ input impedance (see [Figure 7](#)) even if the power is off ($V_{CC} = 0V$). The receivers' Schmitt trigger input stage uses hysteresis to increase noise immunity and decrease errors due to slow input signal transitions. Receiver outputs swing from GND to V_L and do not tristate in powerdown (see [Table 5](#)).

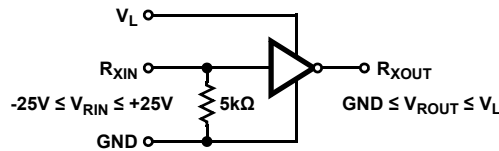

Figure 7. Receiver Connections

4.4 Low Power Operation

During normal operation (not in powerdown mode), this 3V device requires a nominal supply current of 0.3mA, even at $V_{CC} = 5.5V$. This current is considerably less than the 11mA current required by comparable 5V RS-232 devices, and it allows you to reduce system power simply by replacing the old style device with the ISL83387E in new designs.

4.5 Powerdown Functionality

The already low current requirement drops significantly when the device enters powerdown mode. In power-down, the supply current drops to $1\mu A$, because the on-chip charge-pump turns off ($V+$ collapses to V_{CC} , $V-$ collapses to GND) and the transmitter outputs tri-state. This micro-power mode makes the device ideal for battery powered and portable applications.

4.5.1 Software Controlled (Manual) Powerdown

The ISL83387E allows you to force the IC into the low power standby state and uses a two pin approach where the FORCEON and FORCEOFF inputs determine the IC's mode. For always enabled operation, FORCEON and FORCEOFF are both strapped high. Under logic or software control, only the FORCEOFF input needs to be driven to switch between active and powerdown modes. The FORCEON state is not critical because FORCEOFF overrides FORCEON. However, if strictly manual control over powerdown is needed, you must strap FORCEON high to disable the automatic powerdown circuitry.

Table 5. Powerdown Logic Truth Table

RCVR or XMTR Edge Within 30 Sec?	FORCEOFF Input	FORCEON Input	Transmitter Outputs	Receiver Outputs	RS-232 Level Present at Receiver Input?	INVALID Output	Mode Of Operation
NO	H	H	Active	Active	NO	L	Normal Operation (Enhanced Auto Powerdown Disabled)
NO	H	H	Active	Active	YES	H	
YES	H	L	Active	Active	NO	L	Normal Operation (Enhanced Auto Powerdown Enabled)
YES	H	L	Active	Active	YES	H	
NO	H	L	High-Z	Active	NO	L	Powerdown Due to Enhanced Auto Powerdown Logic
NO	H	L	High-Z	Active	YES	H	
X	L	X	High-Z	Active	NO	L	Manual Powerdown
X	L	X	High-Z	Active	YES	H	
INVALID Driving FORCEON and FORCEOFF (Emulates Automatic Powerdown)							
X	NOTE 3	NOTE 3	Active	Active	YES	H	Normal Operation
X	NOTE 3	NOTE 3	High-Z	Active	NO	L	Forced Auto Powerdown

Notes:

6. Input is connected to INVALID Output.

Connecting $\overline{\text{FORCEOFF}}$ and FORCEON together disables the enhanced automatic powerdown feature, enabling them to function as a manual SHUTDOWN input (see [Figure 8](#)).

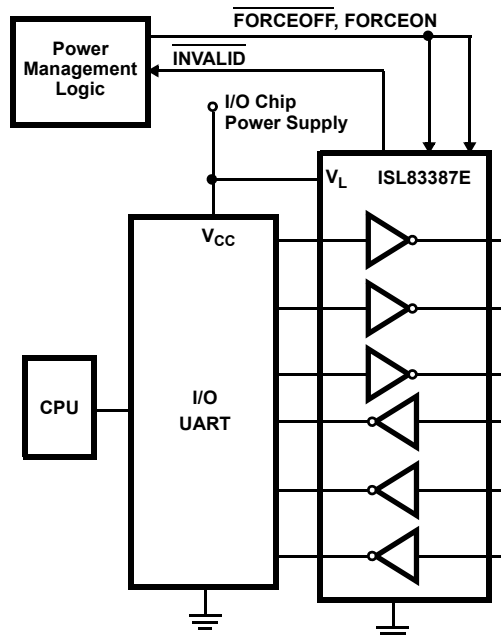

Figure 8. Connections for Manual Powerdown

With any of the control schemes, the time required to exit powerdown, and resume transmission is only 100µs.

When using both manual and enhanced automatic power-down ($\text{FORCEON} = 0$), the ISL83387E does not power up from manual powerdown until both $\overline{\text{FORCEOFF}}$ and FORCEON are driven high, or until a transition occurs on a receiver or transmitter input. [Figure 9](#) shows a circuit for ensuring that the ISL83387E powers up as soon as $\overline{\text{FORCEOFF}}$ switches high. The rising edge of the master powerdown signal forces the device to power up, and the ISL83387E returns to enhanced automatic powerdown mode an RC time constant after this rising edge. The time constant isn't critical, because the ISL83387E remains powered up for 30 seconds after the FORCEON falling edge, even if there are no signal transitions. The delay gives the slow-to-wake systems (such as a mouse) plenty of time to start transmitting, and as long as it starts transmitting within 30 seconds both systems remain enabled.

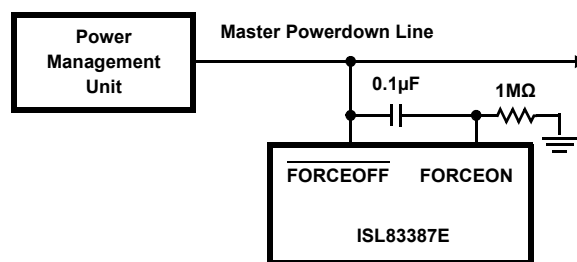

Figure 9. Circuit to Ensure Immediate Power Up When Exiting Forced Powerdown

4.5.2 $\overline{\text{INVALID}}$ Output

The $\overline{\text{INVALID}}$ output always indicates (see [Table 5 on page 11](#)) whether 30µs have elapsed with invalid RS-232 signals (see [Figures 10](#) and [13](#)) persisting on all of the receiver inputs, and it provides a way to determine when the interface block should power down. Invalid receiver levels occur whenever the driving peripheral's outputs are shut off (powered down) or when the RS-232 interface cable is disconnected. If an interface cable is disconnected and all the receiver inputs are floating (but pulled to GND by the internal receiver pull down resistors), the $\overline{\text{INVALID}}$ logic detects the invalid levels and drives the output low. The power management logic then uses this indicator to power down the interface block. Reconnecting the cable restores valid levels at the receiver inputs,

$\overline{\text{INVALID}}$ switches high, and the power management logic wakes up the interface block. $\overline{\text{INVALID}}$ can also be used to indicate the DTR or RING INDICATOR signal as long as the other receiver inputs are floating or driven to GND (as in the case of a powered down driver).

$\overline{\text{INVALID}}$ switches high 1 μs after detecting a valid RS-232 level on a receiver input. $\overline{\text{INVALID}}$ operates in all modes (forced or automatic powerdown, or forced on), so it is also useful for systems employing manual power-down circuitry.

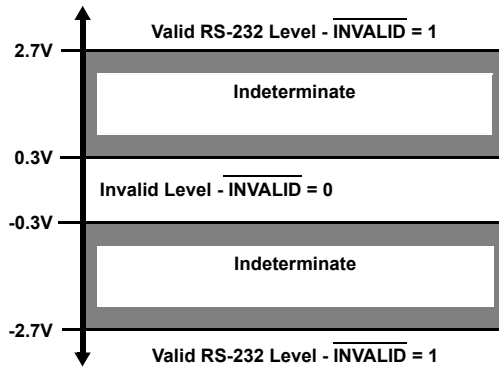

Figure 10. Definition of Valid RS-232 Receiver Levels

4.5.3 Enhanced Automatic Powerdown

Even greater power savings are available by using the enhanced automatic powerdown function. When the enhanced powerdown logic determines that no transitions have occurred on any of the transmitter nor receiver inputs for 30 seconds, the charge-pump and transmitters power-down and reduce the supply current to 1 μA . The ISL83387E automatically powers back up whenever it detects a transition on one of these inputs. This automatic powerdown feature provides additional system power savings without changes to the existing operating system.

Enhanced automatic powerdown operates when the FORCEON input is low, and the $\overline{\text{FORCEOFF}}$ input is high. Tying FORCEON high disables automatic powerdown, but manual powerdown is always available using the overriding $\overline{\text{FORCEOFF}}$ input. Table 5 summarizes the enhanced automatic powerdown functionality.

Figure 11 illustrates the enhanced powerdown control logic. Note: When the ISL83387E enters powerdown (manually or automatically), the 30 second timer remains timed out (set), keeping the ISL83387E powered down until FORCEON transitions high, or until a transition occurs on a receiver or transmitter input.

The $\overline{\text{INVALID}}$ output switches low whenever invalid levels have persisted on all of the receiver inputs for more than 30 μs (see Figure 13 on page 14), but this has no direct effect on the state of the ISL83387E (see the next sections for methods of using $\overline{\text{INVALID}}$ to power down the device).

The time to recover from automatic powerdown mode is typically 100 μs .

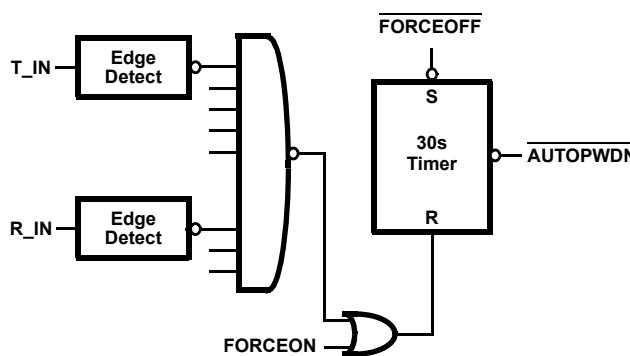

Figure 11. Enhanced Automatic Powerdown Logic

4.5.4 Emulating Standard Automatic Powerdown

If enhanced automatic powerdown is not required, you can implement the standard automatic powerdown feature (mimics the function on the ICL3221E/23E/43E) by connecting the $\overline{\text{INVALID}}$ output to the FORCEON and FORCEOFF inputs, as shown in Figure 12.

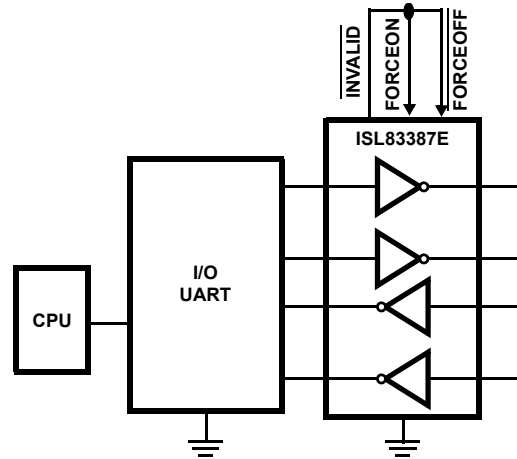

Figure 12. Connections for Automatic Powerdown when no Valid Receiver Signals Are Present

After 30 μs of invalid receiver levels, $\overline{\text{INVALID}}$ switches low and drives the ISL83387E into a forced powerdown condition. $\overline{\text{INVALID}}$ switches high as soon as a receiver input senses a valid

RS-232 level, forcing the ISL83387E to power on. See the “ $\overline{\text{INVALID}}$ Driving FORCEON and FORCEOFF” section of Table 5 on page 11 for an operational summary. This operational mode is perfect for handheld devices that communicate with another computer using a detachable cable. Detaching the cable allows the internal receiver pull-down resistors to pull the inputs to GND (an invalid RS-232 level), causing the 30 μs timer to time-out and drive the IC into powerdown. Reconnecting the cable restores valid levels, causing the IC to power back up.

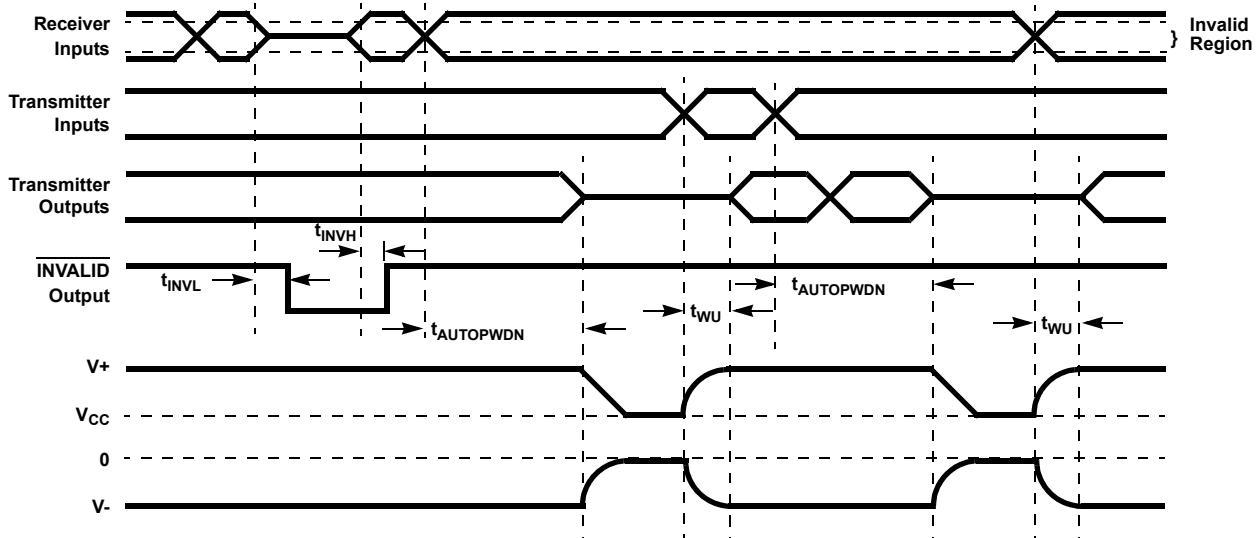

Figure 13. Enhanced Automatic Powerdown and $\overline{\text{INVALID}}$ Timing Diagrams

4.5.5 Hybrid Automatic Powerdown Options

For devices that communicate only through a detachable cable, $\overline{\text{INVALID}}$ can be connected to $\overline{\text{FORCEOFF}}$ (with $\text{FORCEON} = 0$). While the cable is attached, $\overline{\text{INVALID}}$ and $\overline{\text{FORCEOFF}}$ remain high, so the enhanced automatic powerdown logic powers down the ISL83387E whenever there is 30 seconds of inactivity on the receiver and transmitter inputs. Detaching the cable allows the receiver inputs to drop to an invalid level (GND), so $\overline{\text{INVALID}}$ switches low and forces the ISL83387E to power down. The ISL83387E remains powered down until the cable is reconnected ($\overline{\text{INVALID}} = \overline{\text{FORCEOFF}} = 1$), and a transition occurs on a receiver or transmitter input (see [Figure 11](#)). For immediate power up when the cable is reattached, connect FORCEON to $\overline{\text{FORCEOFF}}$ through a network similar to that shown in [Figure 9 on page 12](#).

4.6 V_L Logic Supply Input

Unlike other RS-232 interface devices where the CMOS outputs swing between 0 and V_{CC} , the ISL83387E features a separate logic supply input (V_L ; 1.8V to 5V, regardless of V_{CC}) that sets V_{OH} for the receiver and $\overline{\text{INVALID}}$ outputs. Connecting V_L to a host logic supply lower than V_{CC} , prevents the ISL83387E outputs from forward biasing the input diodes of a logic device powered by that lower supply. Connecting V_L to a logic supply greater than V_{CC} ensures that the receiver and $\overline{\text{INVALID}}$ output levels are compatible even with the CMOS input V_{IH} of AC, HC, and CD4000 devices. Note: The V_L supply current increases to 100 μA with $V_L = 5\text{V}$ and $V_{CC} = 3.3\text{V}$ (see [Figure 6](#)). V_L also powers the transmitter and logic inputs, thereby setting their switching thresholds to levels compatible with the logic supply. This separate logic supply pin allows a great deal of flexibility in interfacing to systems with different logic supplies. If logic translation is not required, connect V_L to the ISL83387E V_{CC} .

4.7 Capacitor Selection

The ISL83387E charge-pumps require only 0.1 μF capacitors for the full operational voltage range. [Table 6](#) lists other acceptable capacitor values for various supply voltage ranges. Do not use values smaller than those listed in [Table 6](#). Increasing the capacitor values (by a factor of 2) reduces ripple on the transmitter outputs and slightly reduces power consumption.

Table 6. Required Capacitor Values

V_{CC} (V)	C_1 (μF)	C_2, C_3, C_4 (μF)
3.0 to 3.6	0.1	0.1
4.5 to 5.5	0.047	0.33
3.0 to 5.5	0.22	1

When using minimum required capacitor values, make sure that capacitor values do not degrade excessively with temperature. If in doubt, use capacitors with a larger nominal value. The capacitor's Equivalent Series Resistance (ESR) usually rises at low temperatures, and it influences the amount of ripple on V_+ and V_- .

4.8 Power Supply Decoupling

In most circumstances a 0.1 μF bypass capacitor is adequate. In applications that are particularly sensitive to power supply noise, decouple V_{CC} to ground with a capacitor of the same value as the charge-pump capacitor C_1 . Connect the bypass capacitor as close as possible to the IC.

4.9 Transmitter Outputs when Exiting Power-Down

[Figure 14](#) shows the response of two transmitter outputs when exiting powerdown mode. As the transmitter outputs activate, they properly go to opposite RS-232 levels, with no glitching, ringing, nor undesirable transients. Each transmitter is loaded with 3k Ω in parallel with 2500pF. Note that the transmitters enable only when the magnitude of the supplies exceed approximately 3V.

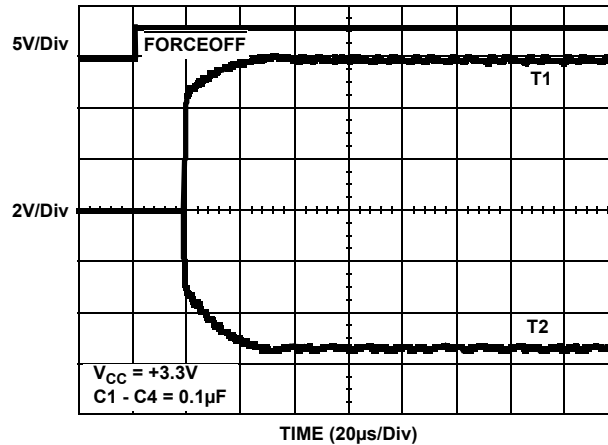

Figure 14. Transmitter Outputs when Exiting Powerdown

4.10 High Data Rates

The ISL83387E maintains the RS-232 $\pm 5V$ minimum transmitter output voltages even at high data rates. [Figure 15](#) shows a transmitter loopback test circuit, and [Figure 16 on page 17](#) shows the loopback test result at 120kbps. For this test, all transmitters were simultaneously driving RS-232 loads in parallel with 1000pF, at 120kbps. [Figure 17 on page 17](#) shows the loopback results for a single transmitter driving 1000pF and an RS-232 load at 250kbps. The static transmitters were also loaded with an RS-232 receiver.

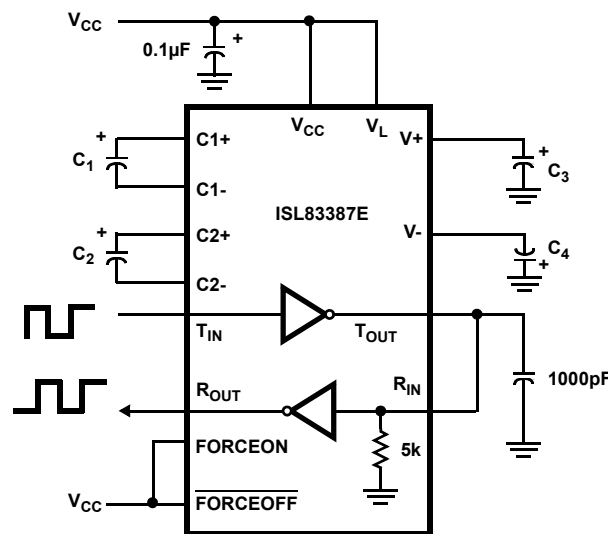

Figure 15. Transmitter Loopback Test Circuit

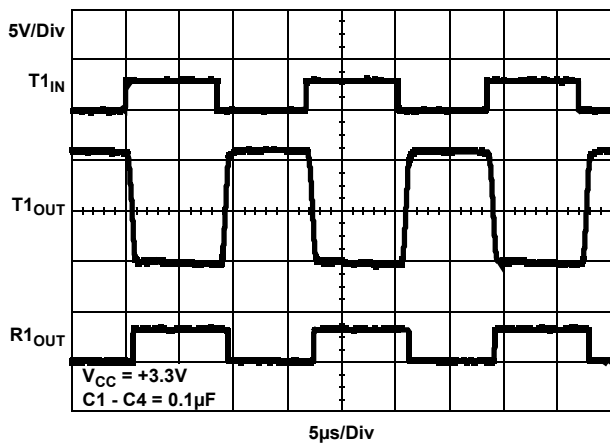

Figure 16. Loopback Test at 120kbps

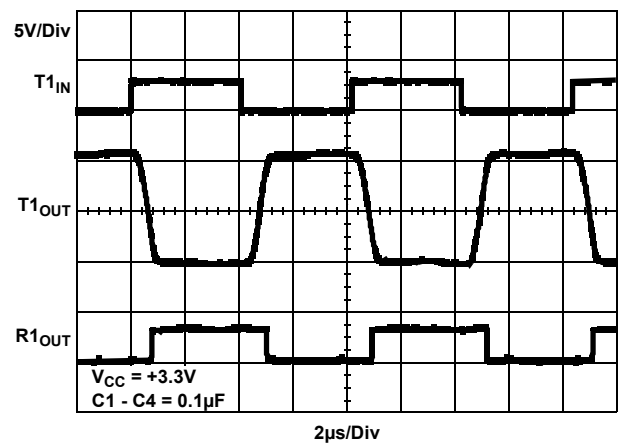

Figure 17. Loopback Test at 250kbps

4.11 Interconnection with 3V and 5V Logic

Standard 3.3V powered RS-232 devices interface well with 3V and 5V powered TTL compatible logic families (such as ACT and HCT), but the logic outputs (for example, R_{OUTS}) fail to reach the V_{IH} level of 5V powered CMOS families like HC, AC, and CD4000. The ISL83387E V_L supply pin solves this problem. By connecting V_L to the same supply (1.8V to 5V) powering the logic device, the ISL83387E logic outputs swing from GND to the logic V_{CC} .

5. ±15kV ESD Protection

All pins on the 3V interface devices include ESD protection structures, but the ISL83387E incorporates advanced structures that allow the RS-232 pins (transmitter outputs and receiver inputs) to survive ESD events up to ±15kV. The RS-232 pins are particularly vulnerable to ESD damage because they typically connect to an exposed port on the exterior of the finished product. Touching the port pins, or connecting a cable, can cause an ESD event that might destroy unprotected ICs. The ESD structures protect the device whether or not it is powered up, protect without allowing any latch-up mechanism to activate, and do not interfere with RS-232 signals as large as ±25V.

5.1 Human Body Model (HBM) Testing

The Human Body Model (HBM) test method emulates the ESD event delivered to an IC during human handling. The tester delivers the charge through a 1.5kΩ current limiting resistor, so the test is less severe than the IEC61000 test, which uses a 330Ω limiting resistor. The HBM method determines an IC's ability to withstand the ESD transients typically present during handling and manufacturing. Due to the random nature of these events, each pin is tested with respect to all other pins. The RS-232 pins on "E" family devices can withstand HBM ESD events to ±15kV.

5.2 IEC61000-4-2 Testing

The IEC61000 test method applies to finished equipment rather than to an individual IC. Therefore, the pins most likely to suffer an ESD event are those that are exposed to the outside world (the RS-232 pins in this case), and the IC is tested in its typical application configuration (power applied) rather than testing each pin-to-pin combination. The lower current limiting resistor coupled with the larger charge storage capacitor yields a test that is much more severe than the HBM test. The extra ESD protection built into this device's RS-232 pins allows the design of equipment that meets Level 4 criteria without the need for additional board level protection on the RS-232 port.

5.2.1 Air-Gap Discharge Test Method

For the air-gap discharge test method, a charged probe tip moves toward the IC pin until the voltage arcs to it. The current waveform delivered to the IC pin depends on factors such as approach speed, humidity, and temperature, so it is difficult to obtain repeatable results. The "E" device RS-232 pins withstand ±15kV air-gap discharges.

5.2.2 Contact Discharge Test Method

During the contact discharge test, the probe contacts the tested pin before the probe tip is energized and eliminates the variables associated with the air-gap discharge. The result is a more repeatable and predictable test, but equipment limits prevent testing devices at voltages higher than ±8kV. All "E" family devices survive ±8kV contact discharges on the RS-232 pins.

6. Die Characteristics

Substrate Potential (Powered Up)	GND
Transistor Count	1063
Process	Si Gate CMOS

7. Revision History

Rev.	Date	Description
2.00	Apr. 19. 19	Applied new format. Updated Links throughout document. Updated Ordering Information table by removing retired parts and updating notes. Added "Charge-Pump Abs Max Ratings" on page 9. Added Revision History Updated package outline drawing M28.173 from revision 0 to revision 1. Convert to new POD format by moving dimensions from table onto drawing and adding land pattern. No dimension changes. Updated Disclaimer.

8. Package Outline Drawing

For the most recent package outline drawing, see [M24.173](#).

M24.173
 24 LEAD THIN SHRINK SMALL OUTLINE PACKAGE (TSSOP)
 Rev 1, 5/10

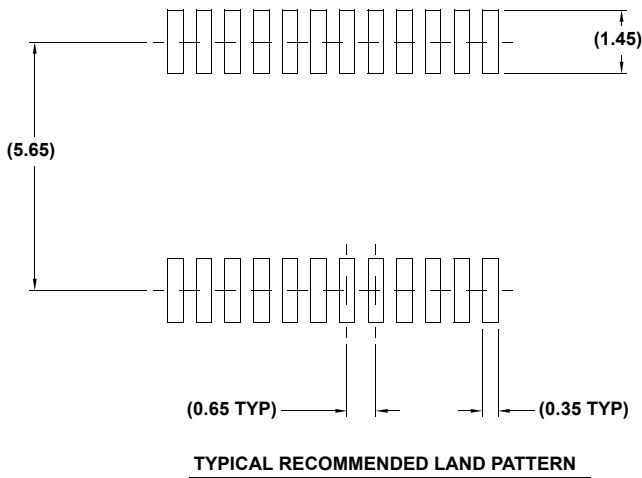
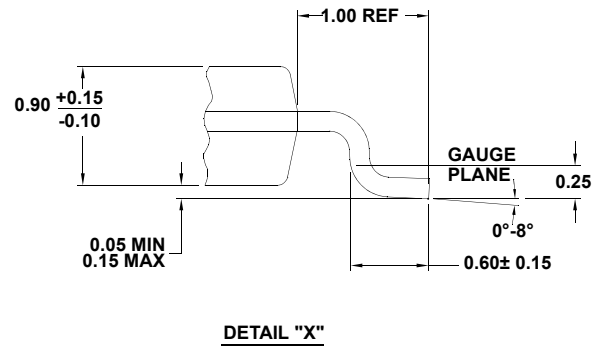
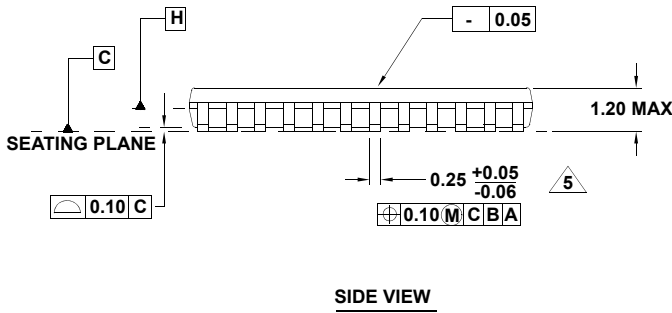
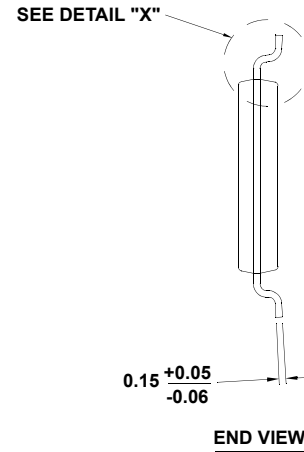
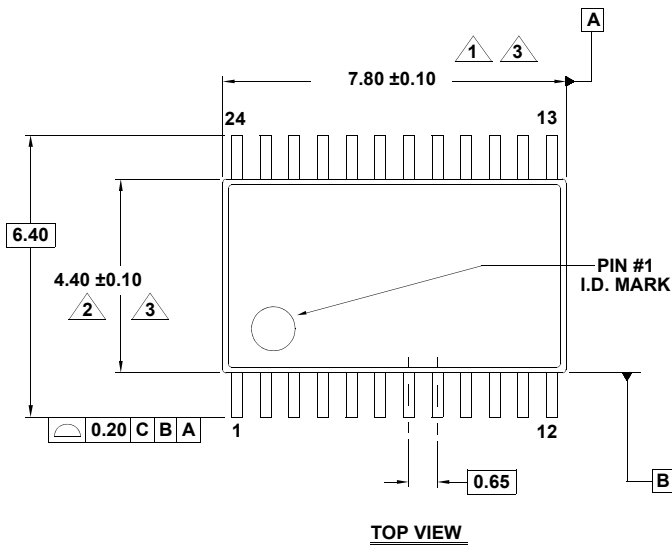

NOTES:

1. Dimension does not include mold flash, protrusions or gate burrs. Mold flash, protrusions or gate burrs shall not exceed 0.15 per side.
2. Dimension does not include interlead flash or protrusion. Interlead flash or protrusion shall not exceed 0.25 per side.
3. Dimensions are measured at datum plane H.
4. Dimensioning and tolerancing per ASME Y14.5M-1994.
5. Dimension does not include dambar protrusion. Allowable protrusion shall be 0.08mm total in excess of dimension at maximum material condition. Minimum space between protrusion and adjacent lead is 0.07mm.
6. Dimension in () are for reference only.
7. Conforms to JEDEC MO-153.

Notice

1. Descriptions of circuits, software and other related information in this document are provided only to illustrate the operation of semiconductor products and application examples. You are fully responsible for the incorporation or any other use of the circuits, software, and information in the design of your product or system. Renesas Electronics disclaims any and all liability for any losses and damages incurred by you or third parties arising from the use of these circuits, software, or information.
2. Renesas Electronics hereby expressly disclaims any warranties against and liability for infringement or any other claims involving patents, copyrights, or other intellectual property rights of third parties, by or arising from the use of Renesas Electronics products or technical information described in this document, including but not limited to, the product data, drawings, charts, programs, algorithms, and application examples.
3. No license, express, implied or otherwise, is granted hereby under any patents, copyrights or other intellectual property rights of Renesas Electronics or others.
4. You shall not alter, modify, copy, or reverse engineer any Renesas Electronics product, whether in whole or in part. Renesas Electronics disclaims any and all liability for any losses or damages incurred by you or third parties arising from such alteration, modification, copying or reverse engineering.
5. Renesas Electronics products are classified according to the following two quality grades: "Standard" and "High Quality". The intended applications for each Renesas Electronics product depends on the product's quality grade, as indicated below.
 - "Standard": Computers; office equipment; communications equipment; test and measurement equipment; audio and visual equipment; home electronic appliances; machine tools; personal electronic equipment; industrial robots; etc.
 - "High Quality": Transportation equipment (automobiles, trains, ships, etc.); traffic control (traffic lights); large-scale communication equipment; key financial terminal systems; safety control equipment; etc.Unless expressly designated as a high reliability product or a product for harsh environments in a Renesas Electronics data sheet or other Renesas Electronics document, Renesas Electronics products are not intended or authorized for use in products or systems that may pose a direct threat to human life or bodily injury (artificial life support devices or systems; surgical implantations; etc.), or may cause serious property damage (space system; undersea repeaters; nuclear power control systems; aircraft control systems; key plant systems; military equipment; etc.). Renesas Electronics disclaims any and all liability for any damages or losses incurred by you or any third parties arising from the use of any Renesas Electronics product that is inconsistent with any Renesas Electronics data sheet, user's manual or other Renesas Electronics document.
6. When using Renesas Electronics products, refer to the latest product information (data sheets, user's manuals, application notes, "General Notes for Handling and Using Semiconductor Devices" in the reliability handbook, etc.), and ensure that usage conditions are within the ranges specified by Renesas Electronics with respect to maximum ratings, operating power supply voltage range, heat dissipation characteristics, installation, etc. Renesas Electronics disclaims any and all liability for any malfunctions, failure or accident arising out of the use of Renesas Electronics products outside of such specified ranges.
7. Although Renesas Electronics endeavors to improve the quality and reliability of Renesas Electronics products, semiconductor products have specific characteristics, such as the occurrence of failure at a certain rate and malfunctions under certain use conditions. Unless designated as a high reliability product or a product for harsh environments in a Renesas Electronics data sheet or other Renesas Electronics document, Renesas Electronics products are not subject to radiation resistance design. You are responsible for implementing safety measures to guard against the possibility of bodily injury, injury or damage caused by fire, and/or danger to the public in the event of a failure or malfunction of Renesas Electronics products, such as safety design for hardware and software, including but not limited to redundancy, fire control and malfunction prevention, appropriate treatment for aging degradation or any other appropriate measures. Because the evaluation of microcomputer software alone is very difficult and impractical, you are responsible for evaluating the safety of the final products or systems manufactured by you.
8. Please contact a Renesas Electronics sales office for details as to environmental matters such as the environmental compatibility of each Renesas Electronics product. You are responsible for carefully and sufficiently investigating applicable laws and regulations that regulate the inclusion or use of controlled substances, including without limitation, the EU RoHS Directive, and using Renesas Electronics products in compliance with all these applicable laws and regulations. Renesas Electronics disclaims any and all liability for damages or losses occurring as a result of your noncompliance with applicable laws and regulations.
9. Renesas Electronics products and technologies shall not be used for or incorporated into any products or systems whose manufacture, use, or sale is prohibited under any applicable domestic or foreign laws or regulations. You shall comply with any applicable export control laws and regulations promulgated and administered by the governments of any countries asserting jurisdiction over the parties or transactions.
10. It is the responsibility of the buyer or distributor of Renesas Electronics products, or any other party who distributes, disposes of, or otherwise sells or transfers the product to a third party, to notify such third party in advance of the contents and conditions set forth in this document.
11. This document shall not be reprinted, reproduced or duplicated in any form, in whole or in part, without prior written consent of Renesas Electronics.
12. Please contact a Renesas Electronics sales office if you have any questions regarding the information contained in this document or Renesas Electronics products.

(Note1) "Renesas Electronics" as used in this document means Renesas Electronics Corporation and also includes its directly or indirectly controlled subsidiaries.

(Note2) "Renesas Electronics product(s)" means any product developed or manufactured by or for Renesas Electronics.

(Rev.4.0-1 November 2017)

Corporate Headquarters

TOYOSU FORESIA, 3-2-24 Toyosu,
Koto-ku, Tokyo 135-0061, Japan
www.renesas.com

Contact Information

For further information on a product, technology, the most up-to-date version of a document, or your nearest sales office, please visit:
www.renesas.com/contact/

Trademarks

Renesas and the Renesas logo are trademarks of Renesas Electronics Corporation. All trademarks and registered trademarks are the property of their respective owners.





Looking for pricing, stock, or lifecycle information?

Click below to explore more details on WIN SOURCE:

 [View ISL83387EIVZ on WIN SOURCE](#)

 [Intersil Information](#)

Optimize Your Supply Chain with WIN SOURCE Solutions

-  Global Sourcing Solution
-  Obsolete Management
-  Cost Control Management
-  Shortage Management
-  Alternative Solution
-  Excess Inventory Management