

SMBus Fan Control with 1°C Accurate Temperature Monitoring

PRODUCT FEATURES

Data Brief

General Description

The EMC2101 is an SMBus 2.0 compliant, integrated fan control solution complete with two temperature monitors, one external and one internal. Each temperature channel has programmable high limits that can assert an interrupt.

The fan drive is selectable as a Pulse Width Modulator (PWM) or Linear (DAC) output. The fan control output, whether the PWM or DAC drive circuit, uses an eight position look-up table to allow the user to program the fan speed profile based on temperature. The DAC output ranges from 0V to V_{DD} with up to 6 bit resolution while the PWM output has a range of 0% to 100% with up to 64 steps.

The EMC2101 has an option to automatically upload the contents of an attached SMBus compatible EEPROM for auto-programming upon power up.

Advanced thermal sensing enables reduced validation and characterization time as well as accurately operating with smaller-geometry processors. Resistance Error Correction (REC) automatically corrects the offset errors of board trace and device resistance, up to 100 Ω . Automatic Beta Compensation allows the user the flexibility to design applications that include processor substrate transistors.

Features

- Automatic Beta Compensation
- Resistance Error Correction
- Self-programming with available SMBus compatible EEPROM
- Selectable PWM or DAC fan driver output
- Temperature Monitors
 - External channel $\pm 1^\circ\text{C}$ accuracy
 - Internal channel $\pm 2^\circ\text{C}$ accuracy
- 3.3 Volt Operation (5 Volt Tolerant Input Buffers)
- SMBus 2.0 Compliant Interface, supports TIMEOUT
- 8-Pin MSOP Lead-free RoHS Compliant Packages
- 8-Pin SOIC Lead-free RoHS Compliant Package

Applications

- Graphics Processors
- Embedded Application Fan Drive
- PWM Controller + Temp Sensor

Block Diagram

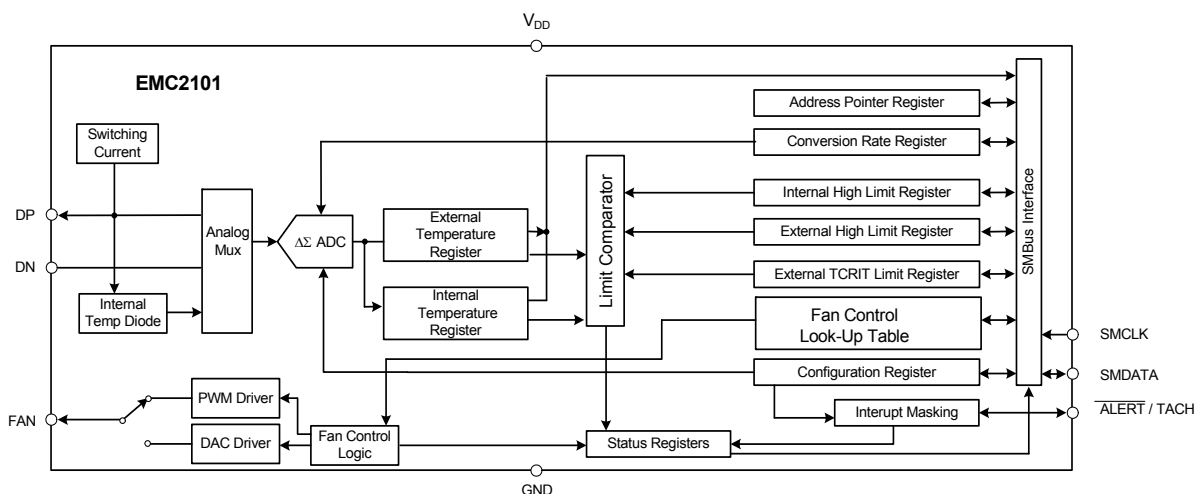

ORDER NUMBERS:**EMC2101-ACZL-TR FOR 8-PIN, MSOP LEAD-FREE ROHS COMPLIANT PACKAGE****EMC2101-R-ACZL-TR FOR 8-PIN, MSOP LEAD-FREE ROHS COMPLIANT PACKAGE****EMC2101-ACZT-TR FOR 8-PIN, SOIC LEAD-FREE ROHS COMPLIANT PACKAGE****REEL SIZE IS 4,000 PIECES**

80 ARKAY DRIVE, HAUPPAUGE, NY 11788 (631) 435-6000, FAX (631) 273-3123

Copyright © 2009 SMSC or its subsidiaries. All rights reserved.

Circuit diagrams and other information relating to SMSC products are included as a means of illustrating typical applications. Consequently, complete information sufficient for construction purposes is not necessarily given. Although the information has been checked and is believed to be accurate, no responsibility is assumed for inaccuracies. SMSC reserves the right to make changes to specifications and product descriptions at any time without notice. Contact your local SMSC sales office to obtain the latest specifications before placing your product order. The provision of this information does not convey to the purchaser of the described semiconductor devices any licenses under any patent rights or other intellectual property rights of SMSC or others. All sales are expressly conditional on your agreement to the terms and conditions of the most recently dated version of SMSC's standard Terms of Sale Agreement dated before the date of your order (the "Terms of Sale Agreement"). The product may contain design defects or errors known as anomalies which may cause the product's functions to deviate from published specifications. Anomaly sheets are available upon request. SMSC products are not designed, intended, authorized or warranted for use in any life support or other application where product failure could cause or contribute to personal injury or severe property damage. Any and all such uses without prior written approval of an Officer of SMSC and further testing and/or modification will be fully at the risk of the customer. Copies of this document or other SMSC literature, as well as the Terms of Sale Agreement, may be obtained by visiting SMSC's website at <http://www.smisc.com>. SMSC is a registered trademark of Standard Microsystems Corporation ("SMSC"). Product names and company names are the trademarks of their respective holders.

SMSC DISCLAIMS AND EXCLUDES ANY AND ALL WARRANTIES, INCLUDING WITHOUT LIMITATION ANY AND ALL IMPLIED WARRANTIES OF MERCHANTABILITY, FITNESS FOR A PARTICULAR PURPOSE, TITLE, AND AGAINST INFRINGEMENT AND THE LIKE, AND ANY AND ALL WARRANTIES ARISING FROM ANY COURSE OF DEALING OR USAGE OF TRADE. IN NO EVENT SHALL SMSC BE LIABLE FOR ANY DIRECT, INCIDENTAL, INDIRECT, SPECIAL, PUNITIVE, OR CONSEQUENTIAL DAMAGES; OR FOR LOST DATA, PROFITS, SAVINGS OR REVENUES OF ANY KIND; REGARDLESS OF THE FORM OF ACTION, WHETHER BASED ON CONTRACT; TORT; NEGLIGENCE OF SMSC OR OTHERS; STRICT LIABILITY; BREACH OF WARRANTY; OR OTHERWISE; WHETHER OR NOT ANY REMEDY OF BUYER IS HELD TO HAVE FAILED OF ITS ESSENTIAL PURPOSE, AND WHETHER OR NOT SMSC HAS BEEN ADVISED OF THE POSSIBILITY OF SUCH DAMAGES.

Package Outlines

Revision 2.54 (06-16-09)

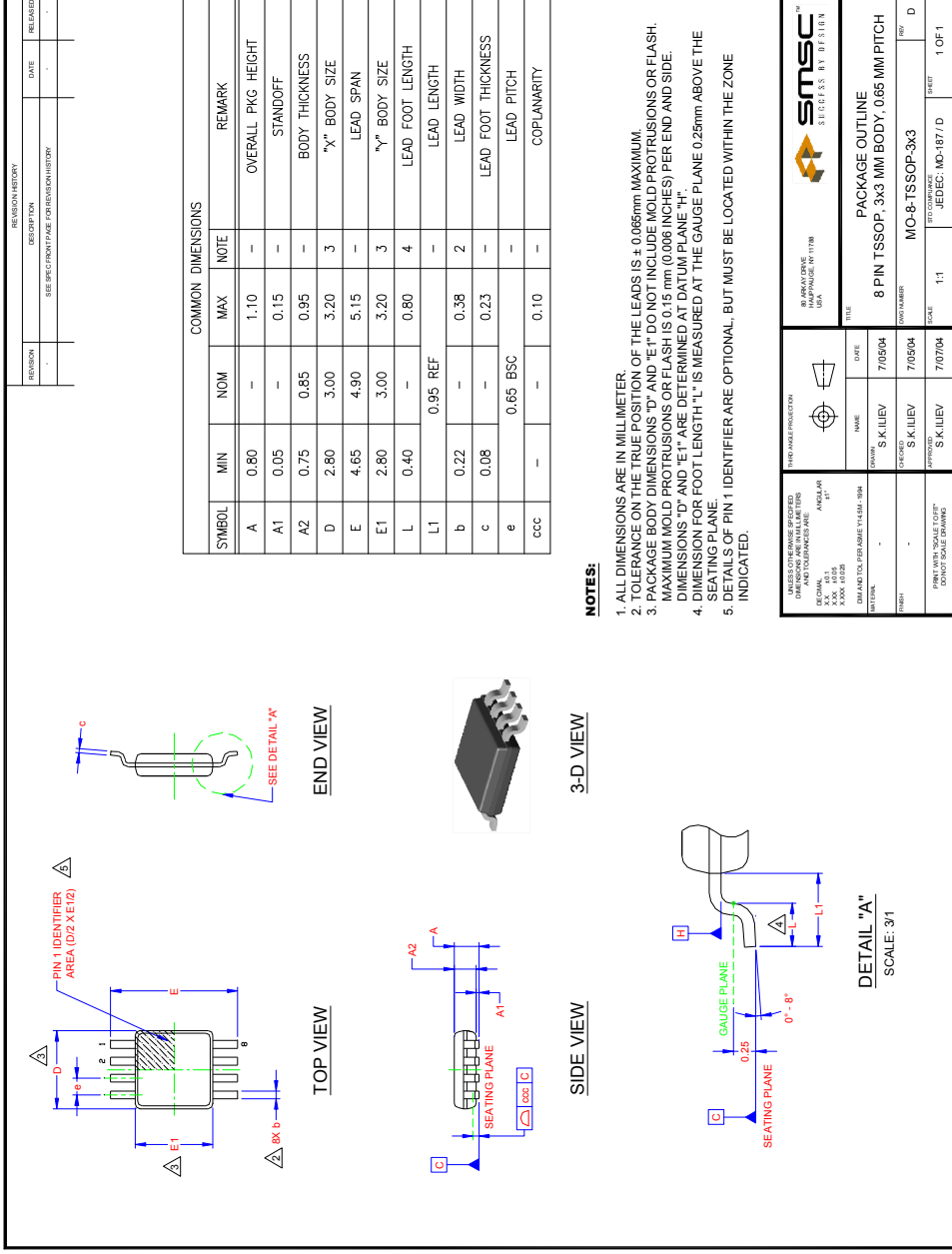

Figure 1 8-PIN MSOP / TSSOP Package

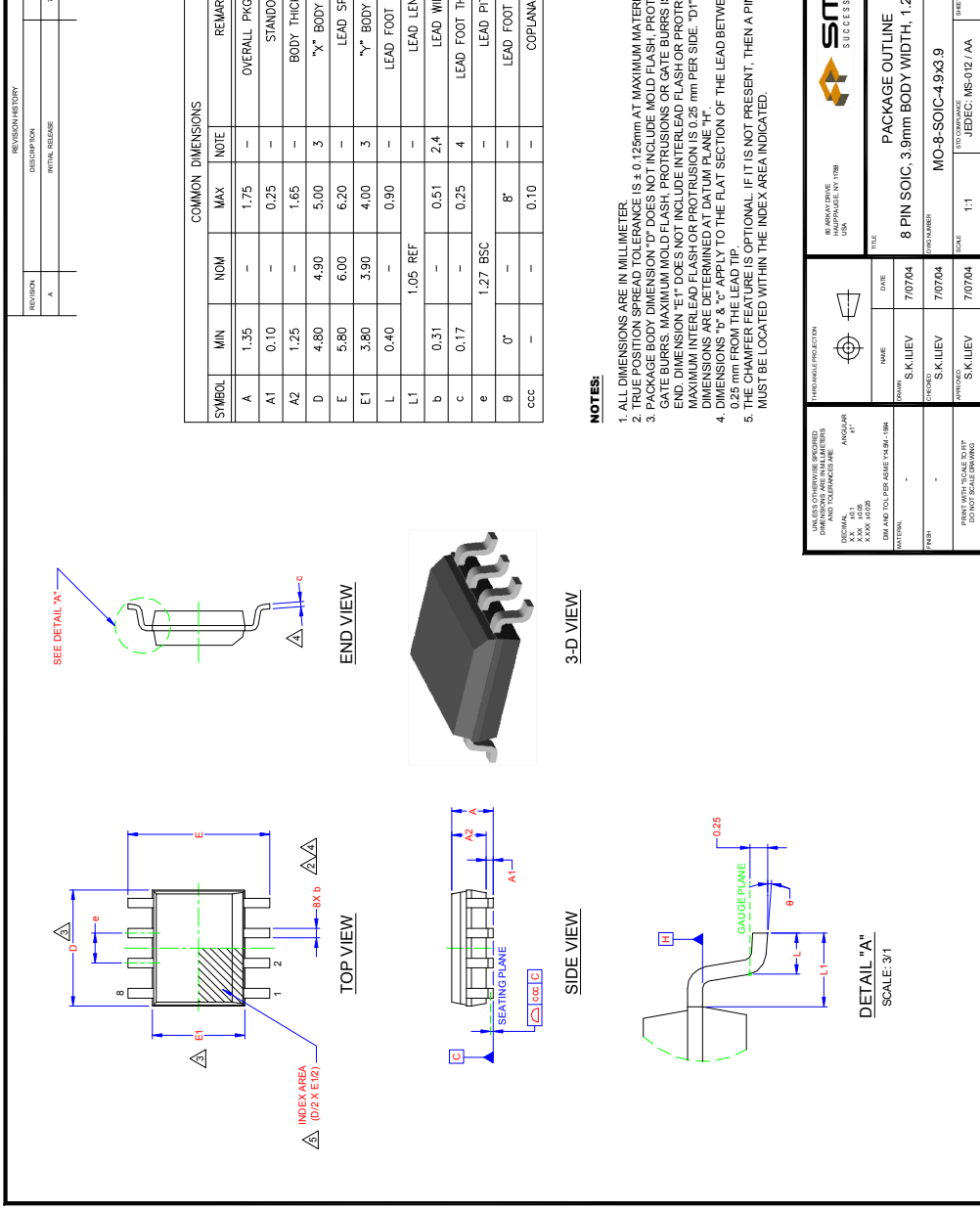

Figure 2 8-PIN SOIC Package

Looking for pricing, stock, or lifecycle information?

Click below to explore more details on WIN SOURCE:

- ⊖ [View EMC2101-ACZL-TR on WIN SOURCE](#)
- ⊖ [Microchip Technology](#) Information

Optimize Your Supply Chain with WIN SOURCE Solutions

- ✓ Global Sourcing Solution
- ✓ Obsolete Management
- ✓ Cost Control Management
- ✓ Shortage Management
- ✓ Alternative Solution
- ✓ Excess Inventory Management